

CDMA REPEATER



CDMA RF REPEATER USER MANUAL

Version 1.0

2007



Contents

1. OVERVIEWS	9
2. COMPONENTS	11
2.1 PACKING LIST	11
2.2 SYSTEM QUICK VIEW	12
2.3 WARNING AND HAZARDS	ERROR! BOOKMARK NOT DEFINED.
3. FEATURES AND SPECIFICATION OF SYSTEM	15
3.1 ELECTRICAL SPECIFICATION.....	15
3.2 MECHANICAL SPECIFICATION	16
3.3 ENVIRONMENT SPECIFICATION	16
3.4 FREQUENCY USED	17
4. SYSTEM BLOCK DIAGRAM	18
4.1 BLOCK DIAGRAM.....	18
4.2 BLOCK DIAGRAM DESCRIPTION	18
5. SYSTEM OVERVIEW	20
5.1 CONSTRUCTION AND FEATURES OF SYSTEM.....	20
5.1.1 PSU (POWER SUPPLY UNIT).....	21
5.1.2 CONTROLLER	21
5.1.3 UP / DOWN CONVERTER	22
5.1.4 FILTER.....	23
5.1.5 PAU(POWER AMPLIFIER UNIT).....	23

CDMA REPEATER



5.1.6 ISOLATION CHECK MODULE	23
5.1.7 CABINET	23
5.2 ADDITIONAL FUNCTIONS	27
5.2.1 AGC FUNCTION.....	27
5.2.2 SHUTDOWN FUNCTION.....	29
5.2.3 OSCILLATION CHECK FUNCTION.....	29
5.2.4 OSCILLATION SHUTDOWN FUNCTION.....	30
6. SYSTEM INSTALLATION GUIDE	31
7. WEB GUI INSTALLATION GUIDE.....	33
7.1 PROGRAM SETUP	33
7.2 WEB GUI CONNECTION	35
7.3 MONITOR/CONTROL OF WEB GUI STATE	37
7.3.1 ACCOUNT	38
7.3.2 USER REGISTRATION.....	39
7.3.3 USER DELETION AND MODIFICATION	39
7.3.4 ALARM HISTORY	40
7.3.5 CONFIG.....	41
7.3.6 UP LOAD	41
8. MAINTENANCE GUIDE.....	45
8.1 CONFIRMATION OF SYSTEM COMPONENTS	45
8.2 CAUTIONS ON SYSTEM INSTALLATION	45

CDMA REPEATER



9. SYSTEM SET UP AND INSPECTION46

9.3.1 INSPECTION OF REPEATER.....47

9.3.2 FACILITY INSPECTION.....48

10 . WARRANTY AND REPAIR POLICY49

☎ CONTACT INFORMATION51

CDMA REPEATER



SK Telesys Co., LTD. All rights reserved.

- Lists of Figures -

< Fig. 1 > Configuration of iDEN Network.....	9
< Fig. 2 > Components of CDMA Repeater.....	11
< Fig. 3 > Front & Back View of CDMA Repeater.....	12
< Fig. 4 > Side View of CDMA Repeater.....	12
< Fig. 5 >Bottom View of CDMA Repeater.....	13
< Fig. 6 > CDMA Frequency.....	17
< Fig. 7 > Block Diagram.....	18
< Fig. 8 > Internal Construction of CDMA Repeater.....	20
< Fig. 9 > Bottom View of CDMA RF Repeater.....	21
< Fig. 10 > Latch Structure.....	24
< Fig. 11 > Hinge Functions.....	25
< Fig. 12 > Swing Handle Function.....	26
< Fig. 13 > Guide for Wrench Prevention.....	27
< Fig. 14 > Mounting Sequence of the CDMA Repeater.....	32
< Fig. 15 > Local Area Connection Properties.....	33
< Fig. 16 > Internet Protocol(TCP/IP) Properties.....	34
< Fig. 17 > Local Area Connection Status-1.....	34
< Fig. 18 > Local Area Connection Status-2.....	35
< Fig. 19 > Web GUI Initial Screen.....	35
< Fig. 20 > Monitoring Screen of i CDMA Repeater State.....	36
< Fig. 21 > Control Screen of CDMA Repeater State.....	36
< Fig. 22 > Input Range Excess Message.....	37
< Fig. 23 > Set Up Completion Message.....	37
< Fig. 24 > Mode Select.....	37
< Fig. 25 > Polling Time.....	38
< Fig. 26 > Function Button.....	38
< Fig. 27 > Logout.....	38
< Fig. 28 > Account Page.....	39
< Fig. 29 > User Registration.....	39
< Fig. 30 > Deletion and Change of User.....	40
< Fig. 31 > Alarm History.....	40
< Fig. 32 > Configuration Information of System.....	41

CDMA REPEATER



< Fig. 33 > Upload Page	41
< Fig. 34 > File Selection.....	43
< Fig. 35 > Upload Arrangement.....	43
< Fig. 36 > Key Value Error	44
< Fig. 37 > Upload Completion.....	44



- Lists of Tables -

<Table 1 > Packing List.....11
<Table 2 > System Features 15
<Table 3 > Figure and Function..... 16
<Table 4 > Environmental specifications..... 16
<Table 5 > CDMA Frequency..... 17

1. Overviews

The RF repeater for CDMA is an economical RF repeater to enable customers who want extension of communication ranges to extend communication ranges by installing repeaters in the building inside, parking lots at the wave shade region, etc.

The RF repeater for CDMA is designed to enable users to select their desired bands(at most 20MHz) among the CDMA 65MHz band. The CDMA repeater is excellent in the frequency selection level and minimizes interference with other signals.

The Controller of the CDMA RF repeater has a local repeater control function to constantly manage and control the repeaters for stable services of the repeaters installed at sites and a remote repeater control function to support remote monitoring and control using a repeater integrated-monitoring system.

The CDMA RF repeater is interlocked with a CDMA repeater integrated-monitoring system using a modem in order to be interlocked with the CDMA repeater integrated-monitoring system.

The internal structure of a CDMA repeater composes a DL(Down Link) converter and UL(Up Link) converter as one-module for optimum size and efficiency and consists of a PSU(Power Supply Unit), filter unit, NMS module, and PAU(Power Amplifier Unit).

All modules except PAU were commonly used for economy and efficiency of operation and enabled system output change only with replacement of PAU and PSU.

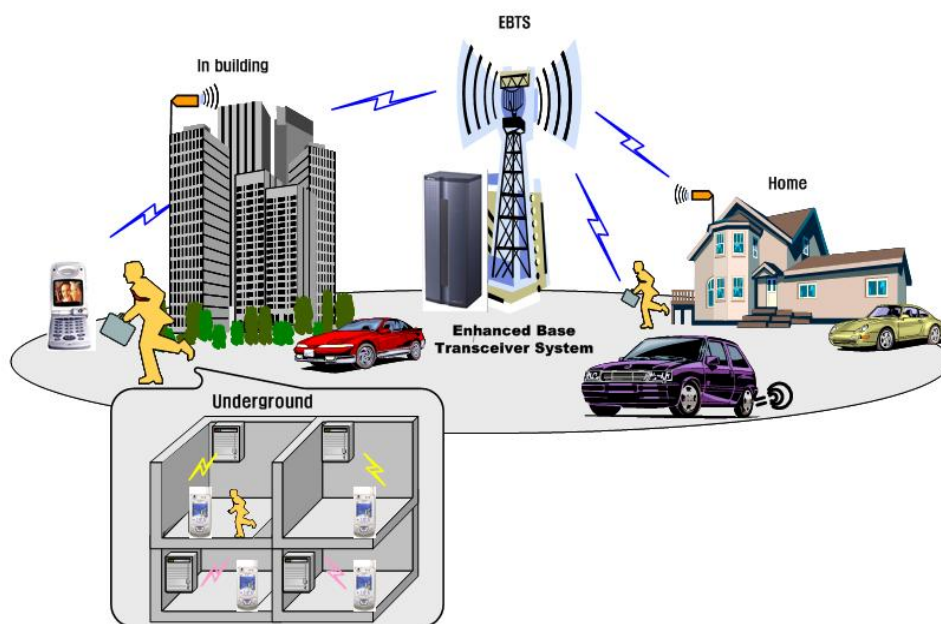

< Fig. 1 > Configuration of CDMA Network

CDMA REPEATER



2. Components

2.1 Packing List

No	Description	Quantity	Remark
1	CDMA Repeater	1	
2	AC Power Cable	1	
3	Ground Cable	1	
4	Bolts to fix the holder	4	
5	KEY	2	
6	CD	1	Manual

<Table 1 > Packing List



< Fig. 2 > Components of CDMA Repeater

CDMA REPEATER



2.2 System Quick View



< Fig. 3 > Front & Back View of CDMA Repeater



< Fig. 4 > Side View of CDMA Repeater

CDMA REPEATER



< Fig. 5 >Bottom View of CDMA Repeater

2.2 Warning and Hazards

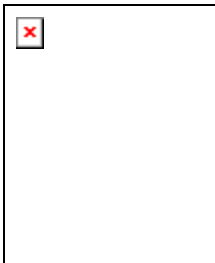

WARNING! ELECTRIC SHOCK

**Danger of electric shock!
Switch off while(it is) maintained and inspected!**

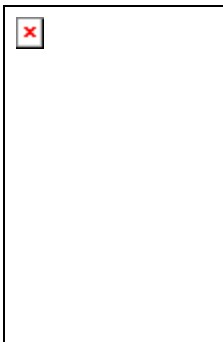

WARNING! EXPOSURE TO RF

Working with the repeater while in operation, may expose the technician to RF electromagnetic fields that exceed FCC rules for human exposure. Visit the FCC website at www.fcc.gov/oet/rfsafety to learn more about the effects of exposure to RF electromagnetic fields.

RF EXPOSURE & ANTENNA PLACEMENT

Actual separation distance is determined upon gain of antenna used. Please maintain a minimum safe distance of at least 20 cm while operating near the donor and the service antennas. Also, the donor antenna needs to be mounted outdoors on a permanent structure.

FCC STATEMENT

This equipment has been tested and found to comply with the limits for a Class A digital device, pursuant to Part 15 of the FCC Rules. These limits are designed to provide reasonable protection against harmful interference when the equipment is operated in a commercial environment. This equipment generates, uses, and can radiate radio frequency energy and, if not installed and used in accordance with the instruction manual, may cause harmful interference to radio communications. Operation of this equipment in a residential area is likely to cause harmful interference in which case the user will be required to correct the interference at own expense.

Warning!

This equipment generates or uses radio frequency energy. Changes or modifications to this equipment may cause harmful interference unless the modifications are expressly approved in the instruction manual. The user could lose the authority to operate this equipment if an unauthorized change or modification is made.

3. Features and Specification of System

3.1 Electrical Specification

Item	Specification	Remark
Frequency Range	Downlink : 1930 ~ 1995 MHz Uplink : 1850 ~ 1915 MHz	
Amplifier Gain / Output Power / Channel	80 dB / 24 dBm	※ CDMA (80/24)
	86 dB / 30 dBm	※ CDMA (86/30)
	93 dB / 37 dBm	※ CDMA (93/37)
Input Level	-16 ~ -56dBm / Total	※ CDMA (80/24)
		※ CDMA (86/30)
		※ CDMA (93/37)
Ripple	± 1.25dB	
Gain Control Range	40 dB(1dB/Step±0.5dB or less)	※ CDMA (80/24)
	46 dB(1dB/Step±0.5dB or less)	※ CDMA (86/30)
	53 dB(1dB/Step±0.5dB or less)	※ CDMA (93/37)
Roll offs	Δ50 dBc or more	@ Band Edge± 1.625 MHz
Spurious RF Emission	-13dBm or less	
Propagation Delay	13 us or less	
Noise Figure	4.5 dB or less	@ Max. Gain (Uplink)
	12 dB or less	@ Min.. Gain (Uplink)
VSWR	1.5 : 1	
Input/output connector	N-Type (Female)	
Input/output impedance	50Ω	
Power	108 ~ 127 VAC, 60Hz	※ Option -40 to -60VDC 20 to 30 VDC

<Table 2 > System Features

3.2 Mechanical Specification

Item	Specification	
Cabinet	Indoor Type	
RF Connector Type (IN/OUT)	N-Type Female	
Dimension (H*W*D)	390 * 326 * 175 mm	※ CDMA (80/24)
	390 * 326 * 195 mm	※ CDMA (86/30)
	390 * 326 * 225 mm	※ CDMA (93/37)
Weight	18.5Kg	※ CDMA (80/24)
	20.0Kg	※ CDMA (86/30)
	21.5Kg	※ CDMA (93/37)

<Table 3 > Figure and Function

3.3 Environment Specification

Item	Specification	Remark
Working temperature/ working humidity	-10℃ ~ 50℃ / 5 % ~ 95%	Temperature and humidity around cabinets
Power	108 ~ 127 VAC, 60Hz	※ Option -40 to -60VDC 20 to 30 VDC

<Table 4 > Environmental specifications

CDMA REPEATER



3.4 Frequency used

Item		Specification	Remark
Down Link	A	1930.625 ~ 1944.375 MHz	BW :13.75 MHz
	D	1945.625 ~ 1949.375 MHz	BW : 3.75 MHz
	B	1950.625 ~ 1964.375 MHz	BW :13.75 MHz
	E	1965.625 ~ 1969.375 MHz	BW : 3.75 MHz
	F	1970.625 ~ 1974.375 MHz	
	C	1975.625 ~ 1989.375 MHz	BW :13.75 MHz
	G	1990.625 ~ 1994.375 MHz	BW : 3.75 MHz
Up Link	A	1850.625 ~ 1864.375 MHz	BW :13.75 MHz
	D	1865.625 ~ 1869.375 MHz	BW : 3.75 MHz
	B	1870.625 ~ 1884.375 MHz	BW :13.75 MHz
	E	1885.625 ~ 1889.375 MHz	BW : 3.75 MHz
	F	1890.625 ~ 1894.375 MHz	
	C	1895.625 ~ 1909.375 MHz	BW :13.75 MHz
	G	1910.625 ~ 1914.375 MHz	BW : 3.75 MHz

<Table 5 > CDMA Frequency

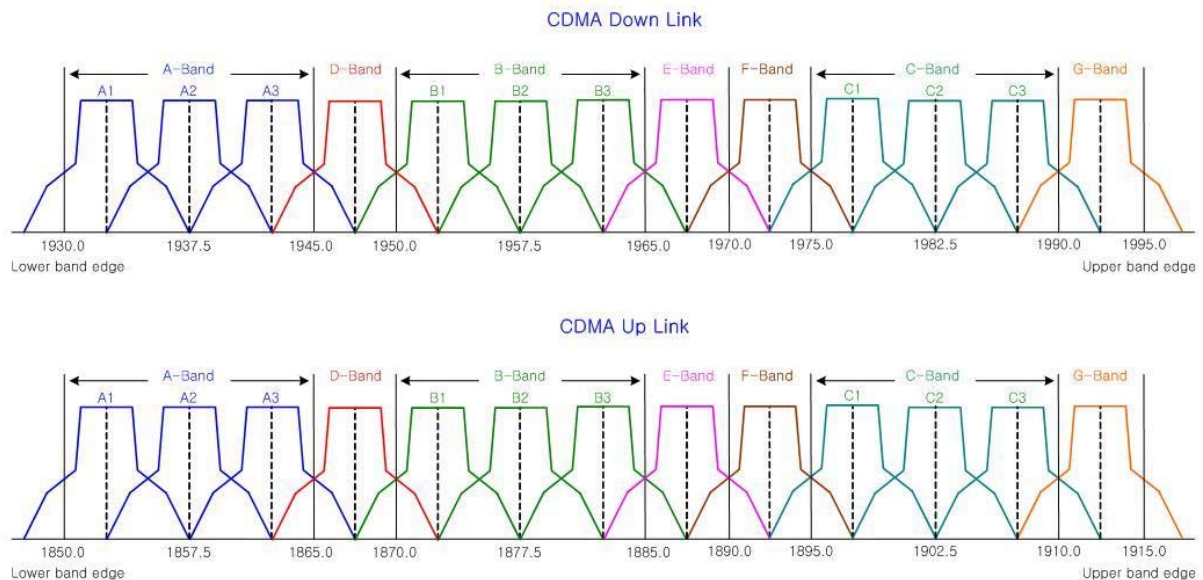

< Fig. 6 > CDMA Frequency

4. System Block Diagram

4.1 Block Diagram

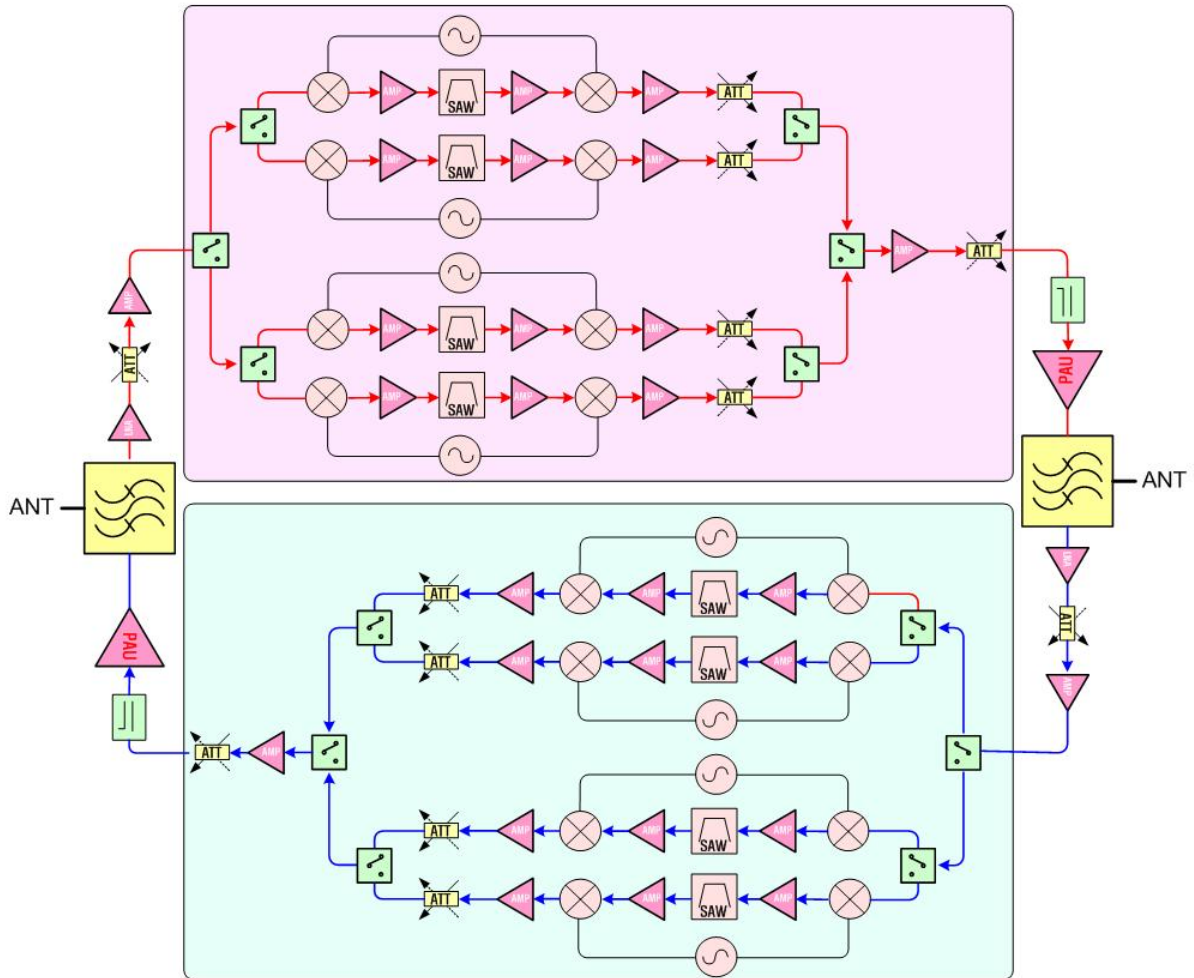

< Fig. 7 > Block Diagram

4.2 Block Diagram description

The filter as a cavity typed one is linked with Donor ANT and Service ANT of CDMA repeater, which selectively passes the broadband wanted between the received signal and terminal signal. Up/Down Converter Module consists of Down converter, Up converter and IF SAW Filter of variable bandwidth from Filter to PAU input between Down link and Up link of CDMA repeater. And to handle two bands of 1900M band and 1800M band same structure comprises in couple. Up/Down converter of the Down Link converts the base station signals inputted through the LNA part into the IF frequency(140MHz), which are divided into 1 path of 20MHz bandwidth and 3

CDMA REPEATER



paths of 5MHz bandwidth.

Each divided signal minimizes influence on other signals, removes spurious waves, and improves separation levels by taking excellent Roll Off characteristics while passing through the IF SAW and intercepting neighboring other bands and signals.

PAU amplifies CDMA signal at proper output level with the module at the final end and passes by Filter to emit through ANT.

5. System Overview

5.1 Construction and Features of System

CDMA RF Repeater is arranged to effectively use the comprising modules when an operator makes up and operates.

CDMA RF Repeater is basically installed by wall, and if required it is constructed to be installed on 19 inch Rack. And, the bottom of the enclosure is provided with 1 donor port, 1 service port, RF for donor monitoring, RF for service monitoring, and AC power terminals respectively.

The internal structure of the CDMA repeater was composed of a DL(Down Link) converter and a UL(Up Link) converter as one module for optimum size and high efficiency and was composed of a PSU(Power Supply Unit), Filter Unit, Controller, and PAU(Power Amplifier Unit).

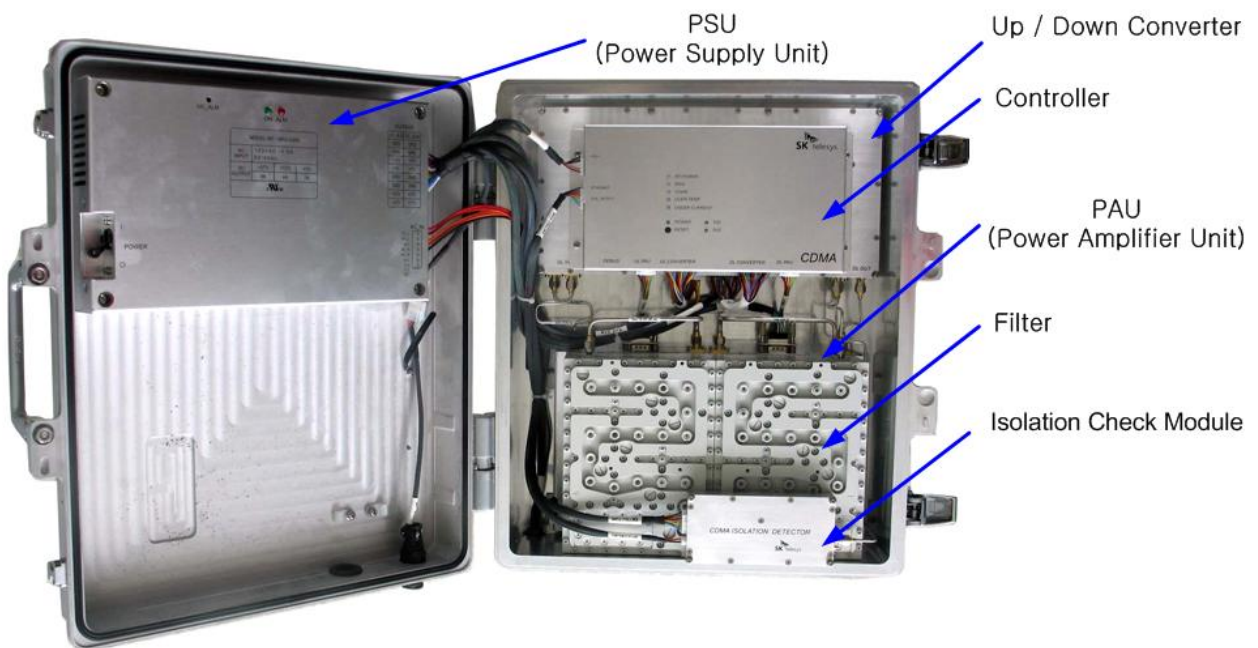

< Fig. 8 > Internal Construction of CDMA Repeater

CDMA REPEATER



< Fig. 9 > Bottom View of CDMA RF Repeater

5.1.1 PSU (Power Supply Unit)

With AC power input for A/D or D/D conversion it is used to supply safe direct current power to each device equipped with active degauss, using main active degauss for industrial or equivalent semi-conducts to satisfy every electrical features with strong nature.

Its power takes AC 108-127V input to convert to DC 7V, DC 12V and DC 27V for use.

5.1.2 Controller

The controller consists of RCB(RF Control Board) and NCB(Network Control Board) to monitor and control the state of each module of CDMA repeater.

RCB(RF Control Board) is linked to GUI through DEBUG port to collect the inspected information of modules and control.

NCB(Network Control Board)enables upper NMS(Ethernet) communication through RJ-45 port to inspect and control the state. It has LED to show the state in NCB(Network Control Board)'s front to easily confirm the abnormal condition of Module.

Since the controller is run by exchangeable batteries, when exchanged in a wrong form, it may explode and used batteries must be safely disposed.

※ Caution

It may explode when exchanged in a wrong form.

Dispose the used batteries according to the direction of manufacturer.

CDMA REPEATER

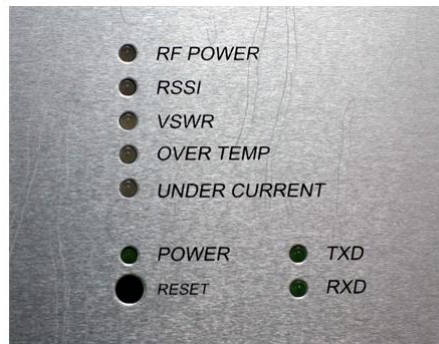

(1) LED

- | | |
|------------------|--|
| a. RF POWER | : On alarming Red light, On normal running Green LED |
| b. RSSI | : On alarming Red light, On normal running Green LED |
| c. VSWR | : On alarming Red light, On normal running Green LED |
| d. OVER TEMP | : On alarming Red light, On normal running Green LED |
| e. UNDER CURRENT | : On alarming Red light, On normal running Green LED |
| f. POWER | : On power admitted Green light, On normal communication Green blinking. |
| h. RESET | : Controller Reset Button |
| i. TXD | : On Data transmitting with Web GUI connected Green blinking |
| j. RXD | : On Data receiving with Web GUI connected Green blinking |

5.1.3 Up / Down Converter

Up/Down converter module is composed of a Down converter and Up converter from the filter to the PAU input in the Down link and Up link of the CDMA repeater.

The Up/Down converter converts the base station signals inputted through the LNA part into the IF frequency(140MHz), which are divided into 1 path of 20MHz bandwidth and 3 paths of 5MHz bandwidth.

Each divided signal minimizes influence on other signals, removes spurious waves, and improves separation levels by taking excellent Roll Off characteristics while passing through the IF SAW and intercepting neighboring other bands and signals.

Insertion of Isolator in front end of Mixer restrains local signal from leaking into Input stage. Mixer applies a degauss with the feature of High IP3 to minimize IMD component of system, maintain linear shape and minimize impact on next stage. BTS signal changed into IF frequency is to be recovered into the original frequency through Up Converter.

Local stage for IF conversion is designed to minimize phase noises in order not to reduce

quality(ρ value) of waveform that can take place during the conversion process of signals.

RF Block of Down Link Up/Down Converter as Down Link Gain Control Block phase performs AGC and ALC functions to protect devices on over-input of CDMA RF Repeater, and with the need of user it may turn On/Off the functions with automatic compensation function for gains on temperature of system.

5.1.4 Filter

As cavity typed filter it is linked to Donor ANT of CDMA Repeater, which selectively passes the wanted band among signals of BTS received with antenna that other bands are removed and band to be served only can be input into LNA phase after acquiring enough Isolation between Down Link and Up Link. And Up Link operates to minimize Spurious power occurred in PAU.

5.1.5 PAU(Power Amplifier Unit)

PAU considers Spurious features to apply degauss with credibility, endurance and high P1dB and inspects at all times output by linking to system's control part. So when main problem happens, it can be reported to upper level and if required by the user PAU move can be On/Off. Down Link PAU amplifies CDMA signal to proper output level and supply Control board with VSWR information of output port and Repeater's output level.

Also detect its own temperature and supply Control board with Device failure to check normal operation state of Module.

5.1.6 Isolation Check Module

The output signals from the Down Link converter of the UP/DOWN converter module is coupled to become an input of the isolation check module. Such signals find the maximum value and minimum value by measuring a oscillation detection value while moving by 50KHz from -250KHz to +250KHz of oscillation check frequency within the module.

When the difference between the maximum value and minimum value is 2dB greater than the setting value, the gain is compensated as much as the difference, and when it is -2dB less than the setting value, the gain is compensated as much as -0.5dB. Isolation is monitored and controlled through such action.

5.1.7 Cabinet

Cabinet of Repeater has Die-Casting structure enabling constructed Module to set up to Door

part to enhance implementation efficiency and minimize the size of cabinet.

Heat dissipation pin of repeater has excellent heat dissipation effect by deciding its length for dissipation by output volume.

(1) Latch

Latch is well sealed and locked to secure safety in which it can play a major role in preventing moisture and vibration.

With automatic lift function of Head, door is easy open and closed. Minimized Shaft's recess of Latch prevents shaking.

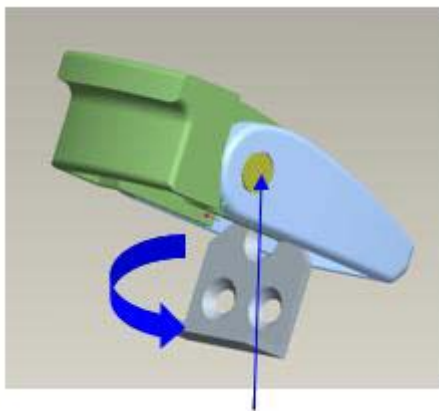

Strengthening Shaft hardness and recess

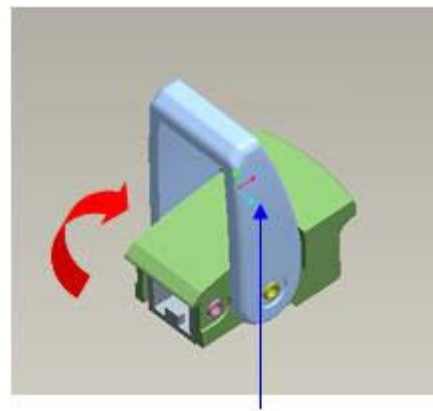

Automatic lift function of Head

< Fig. 10 > Latch Structure

(2) Hinge

On assembling and maintaining cabinet it is designed to consider convenience and rapidity for its opening and closing, and it has 3 merits such as Torque, Stopper and Separation Angle function.

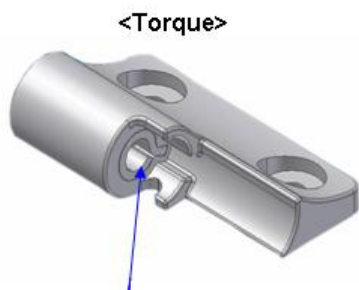

Torque function realizatio

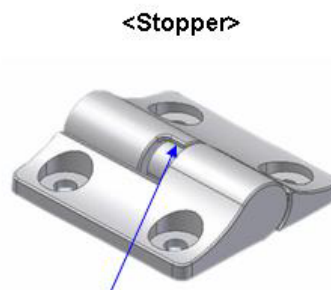

A stopper function when opening cabinets

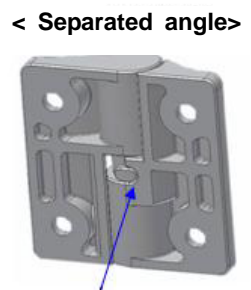

Separation when opening cabinets



< Fig. 11 > Hinge Functions

A. Torque Function

With Torque function embodiment it prevents sudden door opening or closing to consider the operator's safety on assembling and operating.

B. Stopper Function

With Stopper function embodiment it keeps sudden door opening from damaging cabinet on maintaining after assembling and set up. The additional design for opening preventing groove has double safety structure for stopping function.

C. Separation Angle Function

Attached Notch to the center bottom of Hinge keeps separation on closing, and as opening in a certain angle (about 20-30 degree) Door and Body part of Cabinet may be separated.

(3) Swing Handle

On moving the cabinet it applies folding typed Handle for safety and convenience, and it has a find view because it can be folded inward.

When Door of Cabinet is open, closed or moved, it is convenient to be reversely lifted to be used. It has strength of Handle considering equipment's weight for delivery safety.

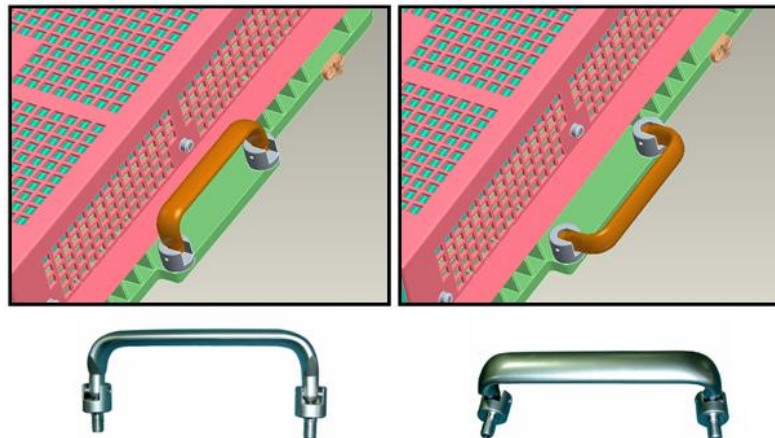

< Fig. 12 > Swing Handle Function

(4) Wrench Prevention Sill

It is put on Door part, which prevents cabinet of repeater from wrenching because of vibration and external environment after set up.

(5) Guide

To keep from wrenching between cabinets after assembling it has Guide function. At the same time contact area extension of Door and Body part of Cabinet enhances heat transmission effect.

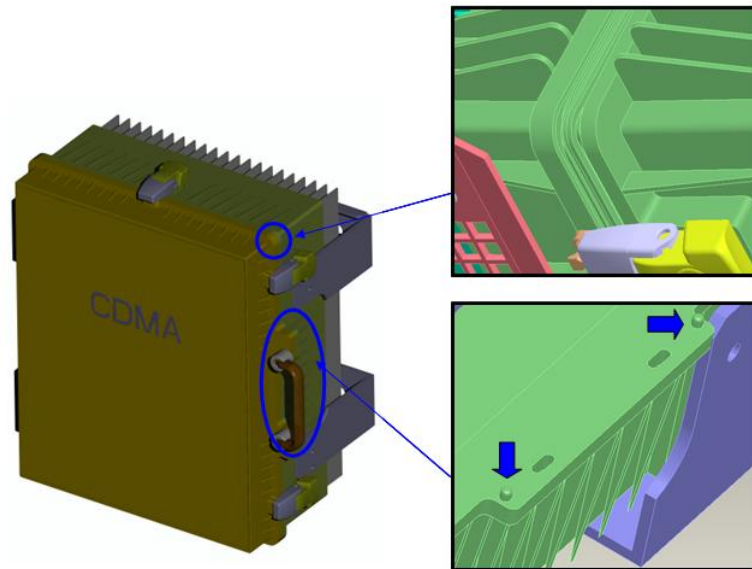

< Fig. 13 > Guide for Wrench Prevention

5.2 Additional Functions

5.2.1 AGC Function

The function is for stable operation of repeater and base station to keep output of repeater from exceeding set up limit.

A. Handling Procedure

- a. Switch ON/OFF AGC function set up through GUI.
- b. When Down Link output value is more than set up level or less than 1.5dB, correct the difference.
- c. When Up Link output value is more than set up level or less than 1.5dB, correct the difference.
- d. Monitor output value of Down Link and Up Link every second.

B. Notes

- a. Down Link and Up link are separately operated.

CDMA REPEATER



-
- b. On oscillation check it does not operate.

5.2.2 Shutdown Function

When output of repeater exceeds set up limit, it is to function Shutdown for stable protection..

A. Handling Procedure

- a. Operate when output value of Down Link and Up Link is 3dB over ALC set up limit.
- b. Inspect output for 5 seconds to find that 5 second output is operation condition.
Then do PAU OFF to perform the first Shutdown move.
- c. Perform PAU ON move 5 seconds after Shutdown move.
- d. Inspect output for 4 seconds again after waiting for stable output for 1 second.
- e. Perform c, d and e move for 3 times.
- f. After 3rd move the PAU ON waiting time is 5 minutes. With Shutdown condition afterward, proceed complete Shutdown state.
- g. On complete Shutdown state the user should directly switch the repeater OFF or ON, or set up PAU ON to come out of complete Shutdown state.

B. Notes

- a. Do not operate when ALC Operation set up is OFF.
- b. Down Link and Up Link are independently operated.

5.2.3 Oscillation Check Function

A. Handling Procedure

- a. Switch ON/OFF oscillation check function with GUI.
- b. Inspect the section between -250KHz and +250KHz based on the frequency found through channel scanning.
- c. Measure the oscillation detection value while moving by 50KHz from -250KHz to +250KHz of oscillation check frequency.
- d. Find the minimum and maximum value from values measured from c.
- e. When the difference between the maximum value and minimum value is 2dB greater than the setting value, the gain is compensated as much as the difference.
- f. When it is -2dB less than the setting value, the gain is compensated as much as - 0.5dB.

B. Notes

- a. Do not operate while channel scan is operating.
- b. When ALC is operating, gain correction value should not exceed ALC set up level.

- c. When Up Link ALC operation is OFF, link Down Link Gain to operate.

5.2.4 Oscillation Shutdown Function

A. Handling Procedure

- a. Operate when oscillation attenuation is over 30dB.
- b. Switch all PAU OFF and start alarming.
- c. Return PAU to original state after 10 seconds to perform oscillation check function.
- d. On continuous Shutdown condition, try 3 times to enter complete Shutdown state afterward.
- e. On complete Shutdown state the user should directly switch the repeater OFF or ON, or set up PAU ON to come out of complete Shutdown state.

B. Notes

- a. Operate when oscillation check function is ON only.

6. System Installation guide

Cabinet of Repeater has Die-Casting structure, in which it basically needs by wall installation and if required it can be installed at 19 inch Rack.

Holder of Repeater has 4 Wall Mount Hole, which needs to safely be installed enough to hold the weight of repeater on installing by wall.

The procedure for installing by wall is as follows;

- (1) Take Repeater out of package.
- (2) Check the components of repeater to remove 12 screws assembled to bracket from the repeater.(6 per side)
- (3) Use 4 anchor bolts to fix bracket to the wall.
- (4) Check if bracket is safely installed to the wall.
- (5) Bracket installed by wall has 2 Guard screws. Lightly lift the repeater on 2 Guard screws to safely fix the other screw.
- (6) Check if it is safely installed safely and firmly.

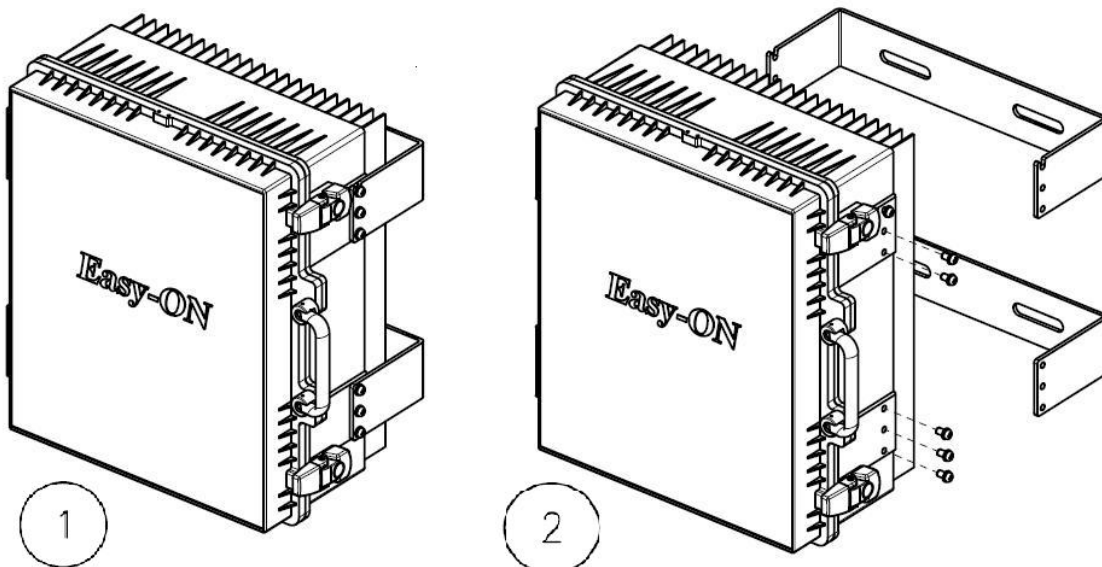

CDMA REPEATER

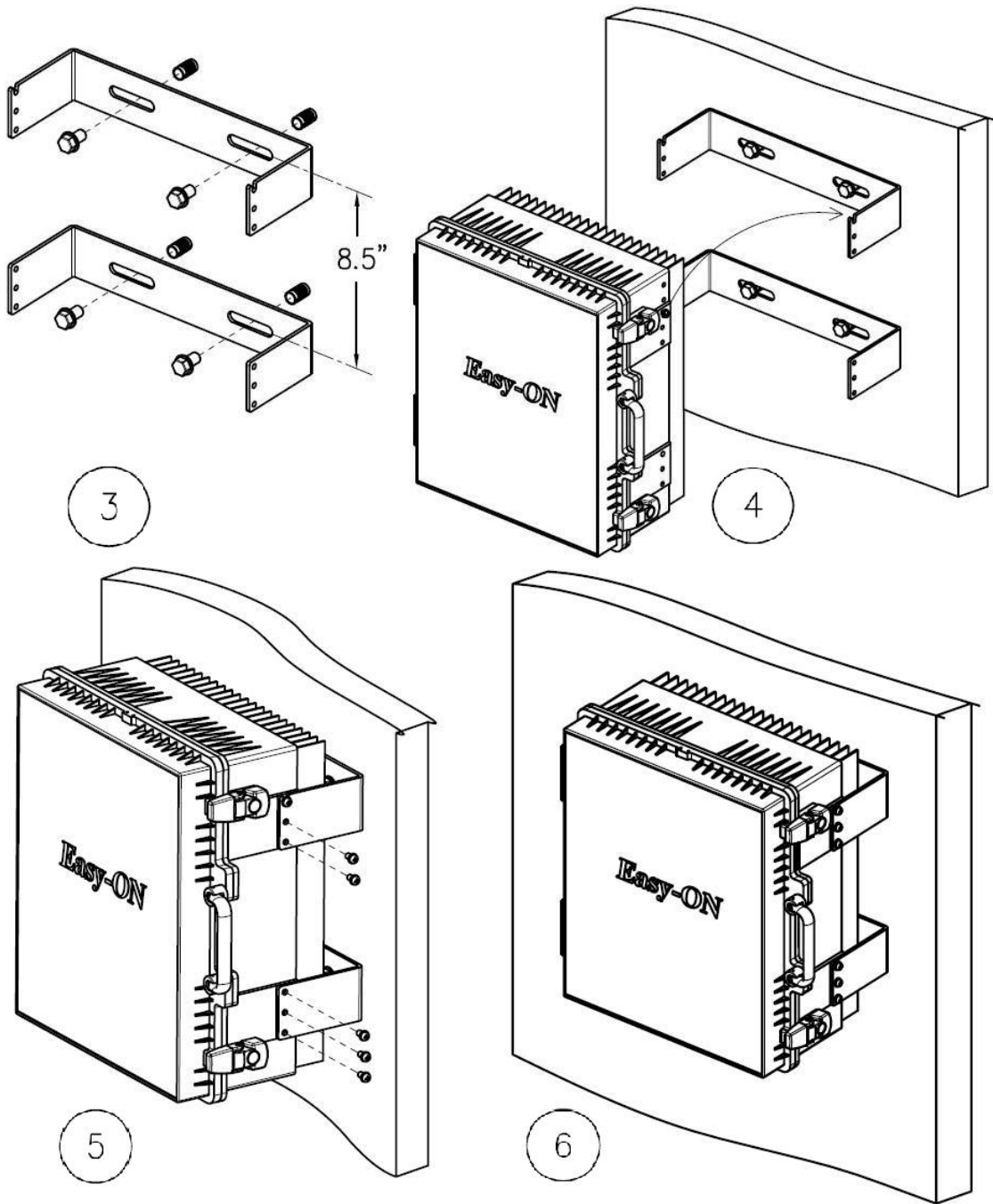

< Fig. 14 > Mounting Sequence of the CDMA Repeater

7. Web GUI Installation guide

7.1 Program Setup

- (1) The Ethernet Ports of Repeater and Laptop are linked through LAN Cable.
- (2) LAN Cable is used as Cross Cable.
- (3) As selecting the following picture, Laptop is automatically assigned IP from the repeater.

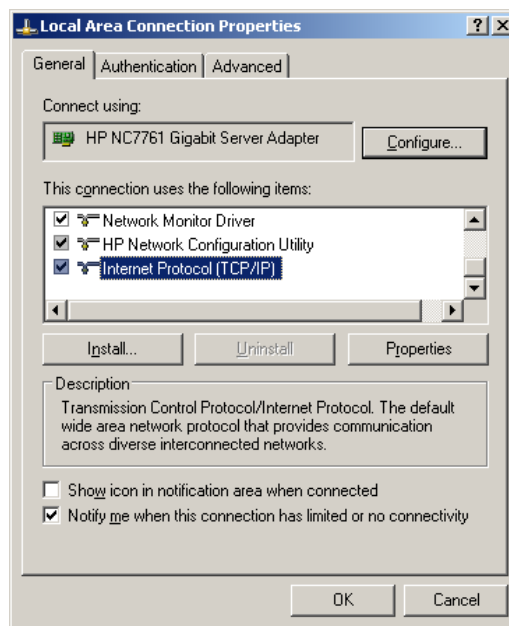

< Fig. 15 > Local Area Connection Properties

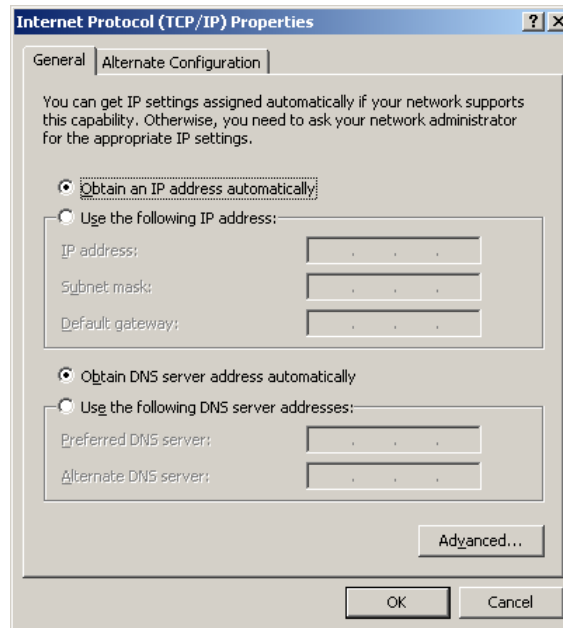

< Fig. 16 > Internet Protocol(TCP/IP) Properties

- (4) When network is not linked in a certain time, select Repair on Support window to recover IP.

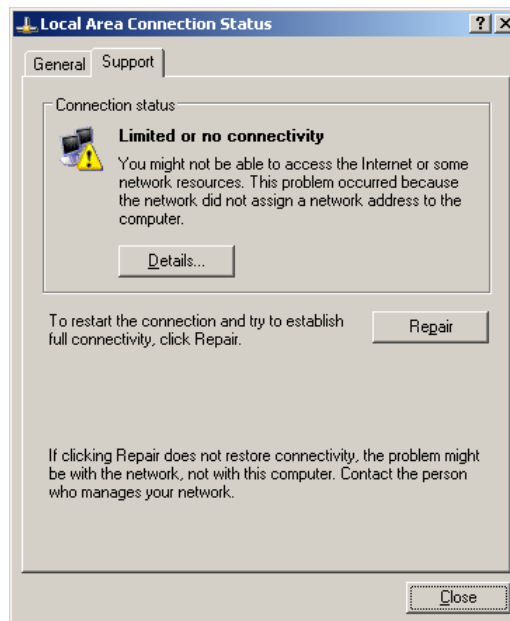

< Fig. 17 > Local Area Connection Status-1

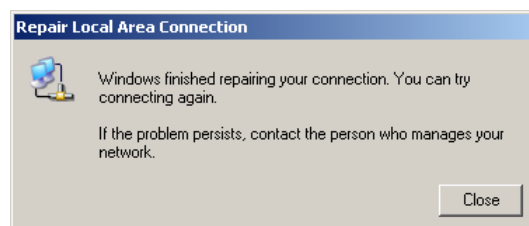

< Fig. 18 > Local Area Connection Status-2

7.2 Web GUI Connection

- (1) Input connection address on address window of Internet Explorer to access.
- (2) The Connection address set up as the repeater is released is as follows;

<http://192.168.10.101/>

As linked to the repeater, input Username and Password on Login screen as follows to click [Login].

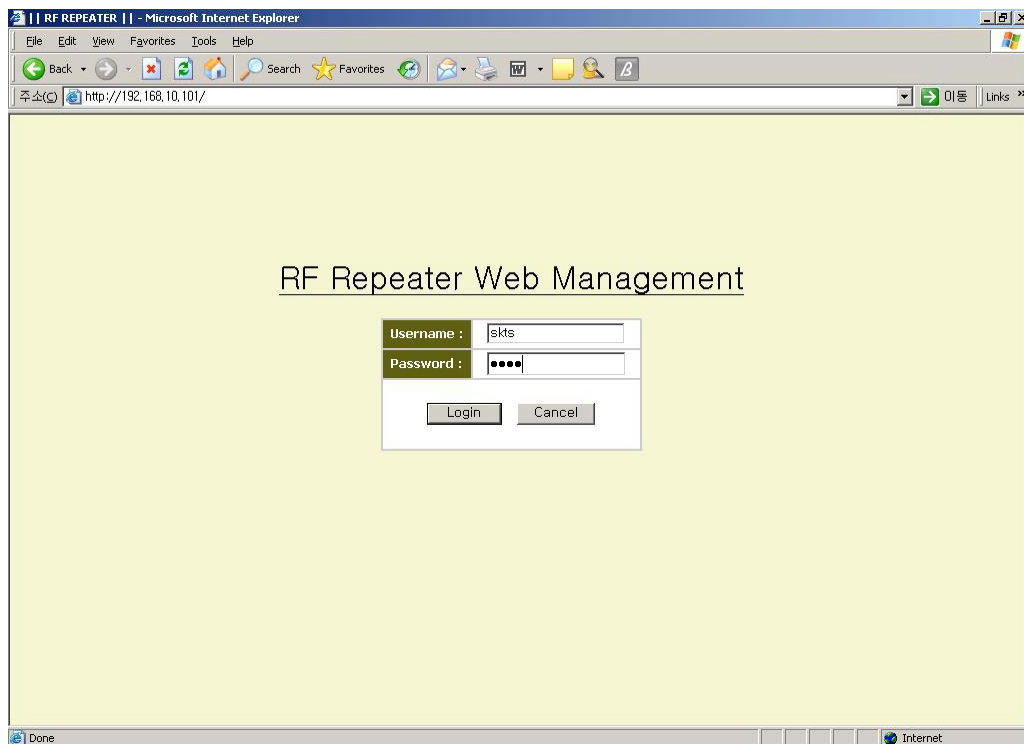

< Fig. 19 > Web GUI Initial Screen

- (3) Default Username & Password set up as the repeater is released are **skts** & **skts**.
- (4) As linked to Web GUI, the following screen appears.

CDMA REPEATER

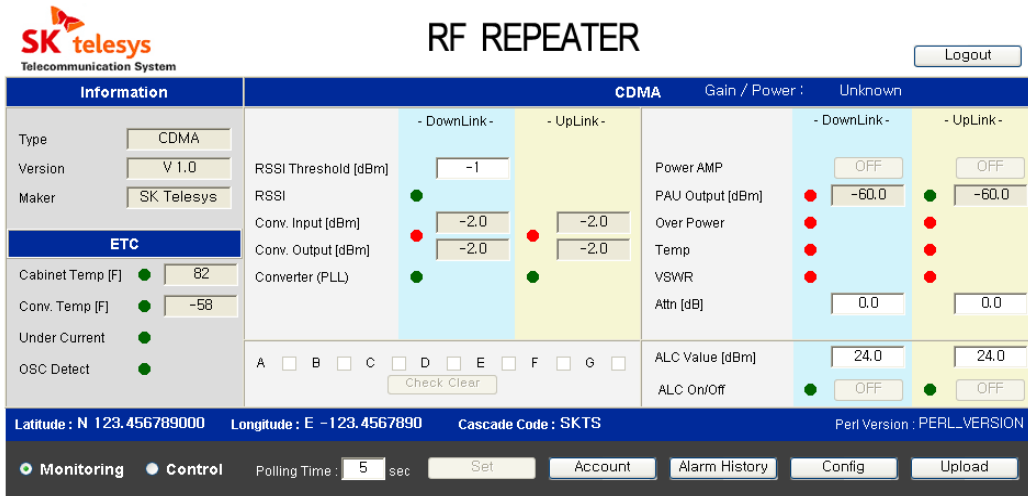

< Fig. 20 > Monitoring Screen of CDMA Repeater State

- (5) After connected, reads the state from repeater system and updates on screen.
- (6) As selecting Control at bottom of connection screen, it stops Polling and activates Set Button and controllable items to change into control mode to alter set up value.

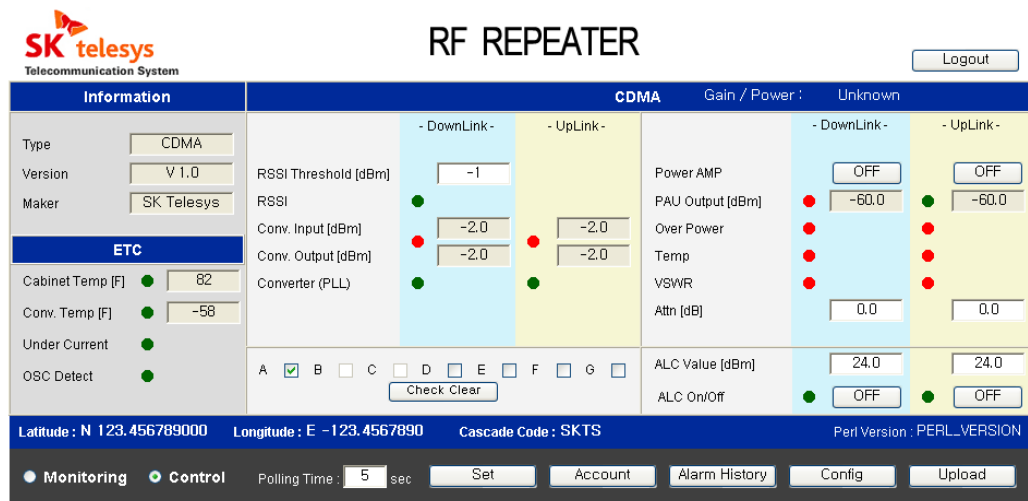

< Fig. 21 > Control Screen of CDMA Repeater State

- (7) On changing set up value when the input range set by items is exceeded, warning window appears to return to the earlier value.

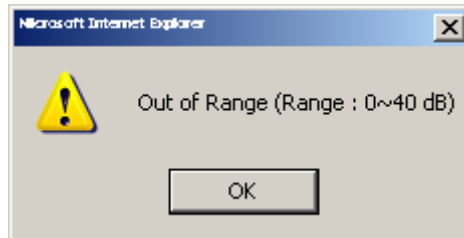

< Fig. 22 > Input Range Excess Message

- (8) After changing set up value, press Set button to transmit the changed data. When set up is completed, the message appears.

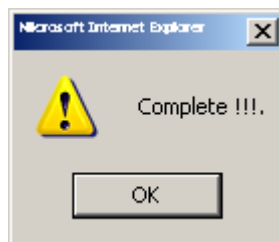

< Fig. 23 > Set Up Completion Message

7.3 Monitor/Control of Web GUI State

You can select Mode Select at bottom of main screen of Web GUI as follows and monitor and control the operation repeater.

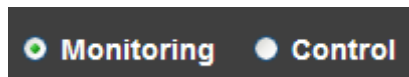

< Fig. 24 > Mode Select

- (1) As selecting Monitoring Mode, it monitors the present state of repeater system.
- (2) As selection Control Mode, it stops Updating of repeater system and changes into controllable Mode.
- (3) The basic Mode after connecting is Monitoring Mode, and after controlling repeater on Control Mode it automatically changes into Monitoring Mode.
- (4) As for Monitoring Mode it is Polling period to update the state from system. It may input between minimum 5 up to 60 seconds.

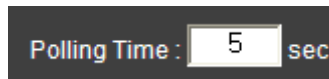

< Fig. 25 > Polling Time

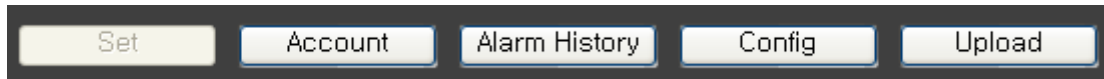

< Fig. 26 > Function Button

- Set : It activates on Control Mode. After changing set up value take down the control on system to change state.
- Account : Manages User's information.
- Alarm History : May show Alarm History Data on system.
- Config : Reads and changes the parameter value affecting system connection.
- Upload : Upload system program.

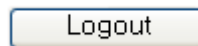

< Fig. 27 > Logout

Ends the present connection.

7.3.1 Account

It can register or delete the users accessible to Use Management page, and the grade of user is divided into Super user and Normal user.

Total maximum user's number available for registration is 4 for super user and 25 for normal user.

On shipment the Default Super User name & Password of repeater are **skts** & **skts**.

As pressing Home button it returns to main screen.

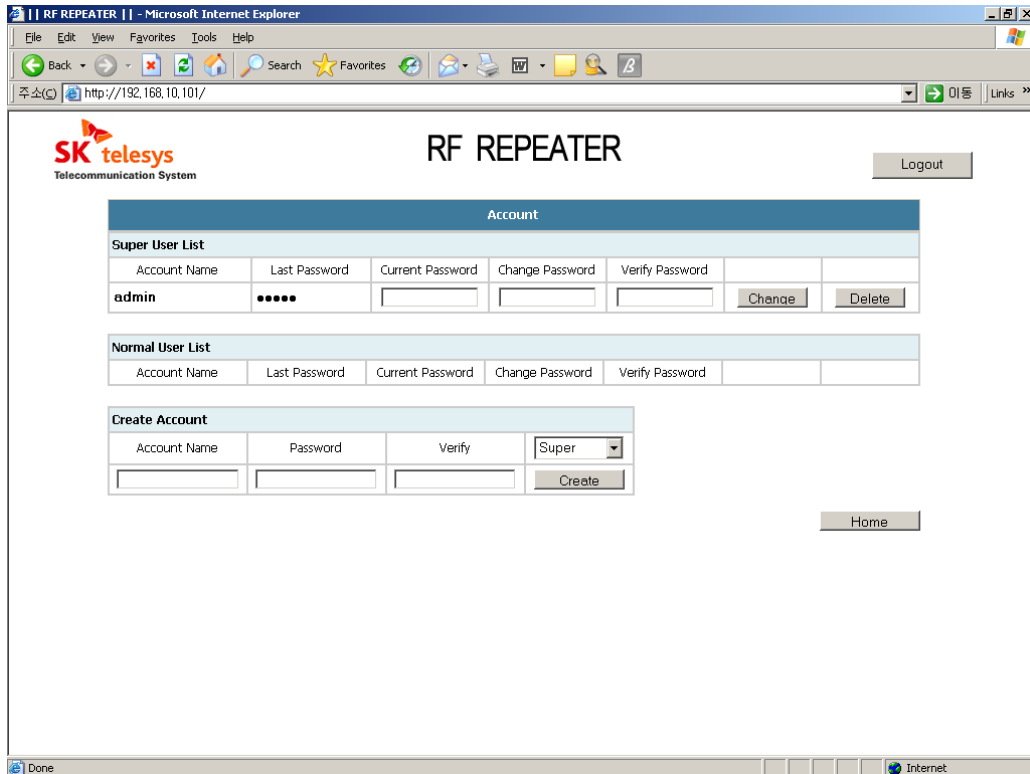

< Fig. 28 > Account Page

7.3.2 User Registration

Select the right of User to register on Create Account Block at the bottom of Page, input User Name and Password to be registered as new and press Create Button to register.

Create Account	Password	Verify	Super
<input type="text" value="Super1"/>	<input type="password" value="••••"/>	<input type="password" value="••••"/>	<input type="button" value="Create"/>

< Fig. 29 > User Registration

7.3.3 User deletion and modification

Deletion of User is Super User's unique right. Press Delete button on the right of User List Block to delete. Deletion of Super User Name is possible only with input of Current Password. Deletion of Normal User is just available by pressing Delete button.

To change Password press Change button to apply after new Password input.

CDMA REPEATER



Account Name	Last Password	Current Password	Change Password	Verify Password		
admin	•••••	<input type="text"/>	<input type="text"/>	<input type="text"/>	Change	Delete

< Fig. 30 > Deletion and Change of User

7.3.4 Alarm History

Alarm details stored in system can be seen, which shows the occurrence time of alarm, its occurrence and release.

Alarm History can be seen up to Index 50.



RF REPEATER

Logout

Alarm History			
Index	Time	Alarm Name	Alarm Status
1	2007/5/14 15:56:43	CDMA DownLink PLL Lock 1	Fail
1	2007/5/14 15:56:43	CDMA UpLink PLL Lock 1	Fail
2	2007/5/14 15:54:59	CDMA DownLink PLL Lock 2	Normal
2	2007/5/14 15:54:59	CDMA UpLink PLL Lock 2	Normal
3	2007/5/14 15:52:50	CDMA DownLink PLL Lock 1	Normal
3	2007/5/14 15:52:50	CDMA DownLink PLL Lock 3	Normal
3	2007/5/14 15:52:50	CDMA UpLink PLL Lock 1	Normal
3	2007/5/14 15:52:50	CDMA UpLink PLL Lock 3	Normal
4	2007/5/14 15:39:16	CDMA DownLink PLL Lock 1	Fail
4	2007/5/14 15:39:16	CDMA DownLink PLL Lock 2	Fail
4	2007/5/14 15:39:16	CDMA DownLink PLL Lock 3	Fail
4	2007/5/14 15:39:16	CDMA DownLink PLL Lock 4	Fail
4	2007/5/14 15:39:16	CDMA UpLink PLL Lock 1	Fail
4	2007/5/14 15:39:16	CDMA UpLink PLL Lock 2	Fail
4	2007/5/14 15:39:16	CDMA UpLink PLL Lock 3	Fail
4	2007/5/14 15:39:16	CDMA UpLink PLL Lock 4	Fail
6	2007/5/12 0:15:36	CDMA UpLink Conv.	Fail
6	2007/5/12 0:15:36	Under Current	Normal
8	2007/5/12 0:3:56	CDMA DownLink RSSI	Normal
9	2007/5/12 0:1:37	CDMA DownLink PLL Lock 4	Normal
9	2007/5/12 0:1:37	CDMA UpLink PLL Lock 4	Normal

Delete

Home

< Fig. 31 > Alarm History

Press Delete button at the bottom to delete alarm details stored, and the deleted alarm details can not be restored.

Press Home button to return to main screen.

7.3.5 Config

It shows basic connection information required to connection and system's construction information, and the initial set up value on shipment is as follows;

The screenshot shows the 'RF REPEATER' configuration page. It includes the SK telesys logo, a 'Logout' button, and several configuration sections:

- Ethernet Configuration:** IP Address (192.168.10.101), Subnet Mask (255.255.255.0), Default Gateway (192.168.10.1), Primary DNS Server (0.0.0.0), Secondary DNS Server (0.0.0.0).
- DHCP Server Configuration:** Enable Server (checked), Lease Area (192.168.10.10 - 192.168.10.50).
- SNMP Configuration:** Site ID (Cascade Code) (SKTS), Sprint Server IP Address, Latitude, Longitude, Trap/Inform Community (public), Heartbeat duration time (min) (30).
- RTC Configuration:** Date (month/day/year) (05/30/2007), Time (hour.min.sec) (13:54:18).

Buttons at the bottom include 'Set', 'Cancel', and 'Home'.

< Fig. 32 > Configuration Information of System

7.3.6 Up Load

Upload Page is necessary to Upgrade the system program.

The screenshot shows the 'RF REPEATER' upload page. It includes the SK telesys logo, the title 'RF REPEATER', and a 'Logout' button. The main section is titled 'UPLOAD' and contains:

- Upload File Name:** A text input field with a 'Browse...' button and an 'Upload' button.
- Key Value:** A text input field.
- Status:** A text area containing the message: 'Select the appropriate file and press the Upload button.'

A 'Home' button is located at the bottom right.

< Fig. 33 > Upload Page

CDMA REPEATER



CDMA REPEATER



Click [Search] button to select the file for Uploading on Popup window.

Controller of repeater comprises Network Control Board and Repeater Control Board, and each Board's Upload file is divided into SKTSNCB_vxx.ncu and SKTSRCB_x_vx.x.xx.rcu.

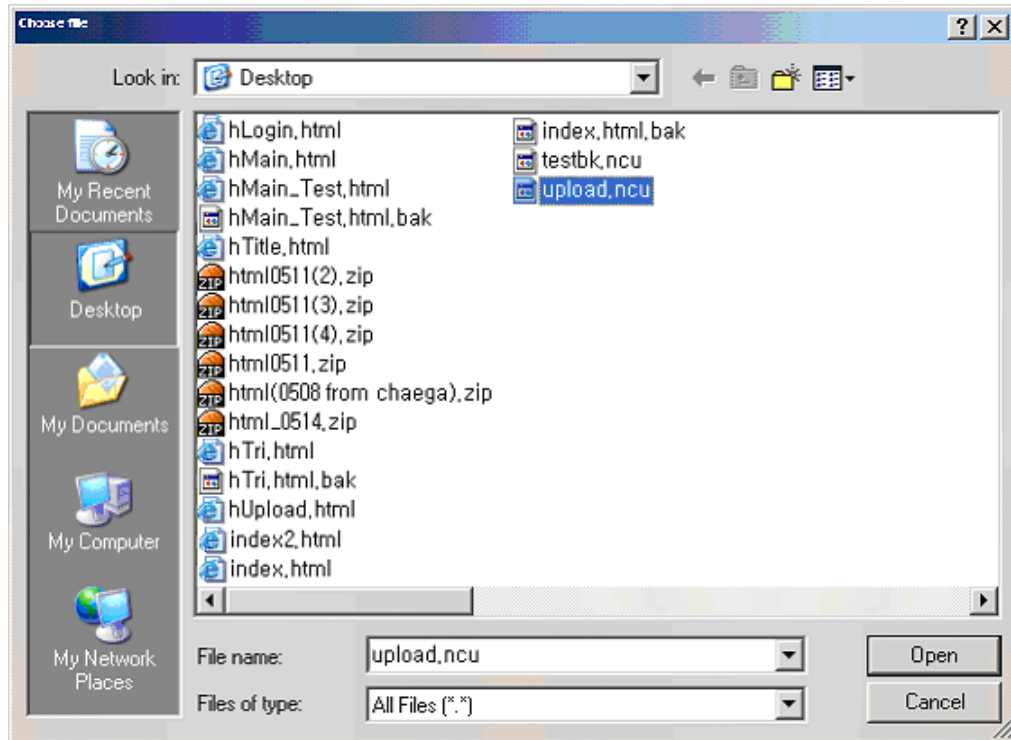

< Fig. 34 > File Selection

UPLOAD	
Upload File Name	C:\WPProject_Web\WTSEX1100\HTML\upload.ncu <input type="button" value="Browse..."/> <input type="button" value="Upload"/>
Key Value	<input type="text" value="4E4F"/>
Status	<input type="text" value="Select the appropriate file and press the Upload button"/>

< Fig. 35 > Upload Arrangement

As the selected file path is seen, input Key Value provided and press Upload button to Upgrade system.

If Key Value is different by files and inaccurate, Upload is impossible.

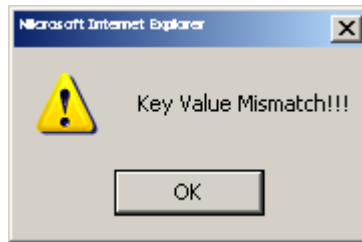

< Fig. 36 > Key Value Error

On completion of Upload, the following message appears and system is automatically rebooted. On rebuttoning connection is not available, after rebooted normal connection is available.

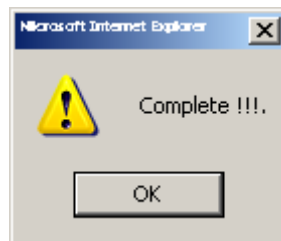

< Fig. 37 > Upload Completion

8. Maintenance Guide

8.1 Confirmation of System Components

For normal operation of equipment the following should be confirmed on installation.

- A. Confirm whether the repeater's exterior would be deformed by damaged package of repeater on delivery.
- B. Confirm that the components of equipment accord and that installation place satisfies temperature and humidity for operation of equipment defined on the product's specification.
- C. Confirm the input signal condition of equipment defined on the product's specification.
- D. Confirm that the state of cable and connector is good.
- E. Confirm that the state of bracket of repeater is good.

8.2 Cautions on System Installation

In order for dangerous events not to occur on installation of repeater, the provided guidance should be followed.

Especially power codes are permanent connection typed so that easily accessible power switch on/off device should be equipped at indoor service wires with outlets easily accessible to repeater.

Order	Description	Cautions
1	Donor ANT welding and feeder installation. Service ANT or LCX equipped	<ul style="list-style-type: none"> • Cable should be installed without exterior damage. • Protect connection parts like connector with insulation tape to prevent humidity. • Install feeder to minimize environment influence.
2	Installation of Antenna for Donor	<ul style="list-style-type: none"> • Strongly fixed for local wind velocity to prevent antenna's direction from bending after installation
3	Power cable and RF cable arrangement	<ul style="list-style-type: none"> • Prevent cable from damaging by crooking or stretching.

9. System Set Up and Inspection

9.1 Items to be checked for Opening

- A. Confirm AC 108 ~ 127 VAC common use power and power cable.
- B. Check if Donor RF input signal from exterior is at normal level.

※ **Caution**

When system operates without input signal confirmed, over-input may cause serious damage on amplifying degauss because of saturation of output. Therefore, after checking input signal level by equipment and ALC ON state(on shipment ALC ON) operate equipment.

- C. Put 108 ~ 127 VAC into power connector of equipment to switch ON.
- D. Check Alarm LED blinking state of GUI or Repeater's front board through laptop.
- E. When it is judged that Down Link RF input signal from exterior is normal, switch OFF the Repeater to connect ANT feed and Service ANT to Input/Output Port of Repeater and switch ON again.

※ **Caution**

Conclude carefully lest Down Link and Up Link Port be reversed.

9.2 Items to be check after opening

- A. Confirm existence of abnormality by checking the alarm LED lighting status of repeaters.
- B. Confirm whether the RF input/output values are normal or not by using GUI.
- C. Confirm the normal operation status of repeaters by measuring the characteristics, etc. of spurious waves of the repeater's down link and up link output using a spectrum waveform analyzer by using a coupling terminal beside each input/output port of the repeater after about 10 or more minutes passes after turning on the power of repeaters.
- D. Optimize the electric wave environments while comparing with the status before opening about whether there is no electric wave shade region or non-communicable region by measuring the communication quality in the service region using a terminal or gauge after normal operation of the repeater.

9.3 Failure and Inspection

9.3.1 Inspection of Repeater

On routine or emergency service of repeater the following orders should be taken to check its failure.

- A. Check RF input/output level and LED of repeater using Web GUI. On routine service check calling quality with terminal or measurer, or on emergency service the following should be taken even if RF input/out level of repeater on Web GUI is normal.
- B. Connect link harmonic analyzer to test terminal of repeater to confirm output state.
- C. Use Coupling port to check output value.
- D. Check if the output value of repeater obtained by harmonic analyzer agrees with actual out put value of repeater.
- E. Check input level of repeater when the output value of repeater obtained by harmonic analyzer does not agree with actual output value of repeater.
- F. When input level is not same as the one on installation time showing distinct difference, check antenna welding state and feeder's installation state.
- G. If the output value of repeater is abnormal as comparing input level to operation gains of repeater, switch ON/OFF the repeater to check the output state with harmonic analyzer. On severe failure immediately replace with spare parts to supply normal service.

CDMA REPEATER



9.3.2 Facility Inspection

On routine Inspection and service failure the following parts and items are needed to be inspected.

Inspection Parts	Inspection Items	Remark
Donor Antenna & Service Antenna	Inspect the malfunction of Antenna's welding, received signal's intensity of donor antenna and RSSI value.	
Feeder, Leakage Coaxial Cable	Inspect whether feeder or leakage coaxial cable may be cut or damaged.	
Connector, Distributor	Inspect whether connector's linking part or cable may be flooded, or whether each linking part is firmly fastened.	
Power Incoming Part	Confirm that common terminal box for 108 ~ 127 VAC is not leaked.	

10 . Warranty and Repair Policy

10.1 General Warranty

This product carries a Standard Warranty period of five (5) years unless indicated otherwise on the package or in the acknowledgment of the purchase order.

10.2 Limitations of Warranty

Your exclusive remedy for any defective product is limited to the repair or replacement of the defective product. SK Telesys Corp. may elect which remedy or combination of remedies to provide in its sole discretion. SK Telesys Corp. shall have a reasonable time after determining that a defective product exists to repair or replace the problem unit. SK Telesys Corp. warranty applies to repaired or replaced products for the balance of the applicable period of the original warranty or ninety days from the date of shipment of a repaired or replaced product, whichever is longer.

10.3 Limitation of Damages

The liability for any defective product shall in no event exceed the purchase price for the defective product.

10.4 No Consequential Damages

SK Telesys Corp. has no liability for general, consequential, incidental or special damages.

10.5 Additional Limitation on Warranty

SK Telesys Corp. standard warranty does not cover products which have been received improperly packaged, altered, or physically damaged. For example, broken warranty seal, labels exhibiting tampering, physically abused SK Telesys Corp. Proprietary Document Page 27 of 31 iDEN RF Repeater User Manual enclosure, broken pins on connectors, any modifications made without SK Telesys Corp. authorization, will void all warranty.

10.6 Return Material Authorization (RMA)

No product may be returned directly to SK Telesys Corp. without first getting an approval from SK Telesys Corp. If it is determined that the product may be defective, you will be given an RMA number and instructions in how to return the product. An unauthorized return, i.e., one for which an RMA number has not been issued, will be returned to you at your expense. Authorized returns are to be shipped to the address on the RMA in an approved shipping container. You will be given our courier information. It is suggested that the original box and packaging materials should be kept if an occasion arises where a defective product needs to be shipped back to SK Telesys Corp. To request an RMA, please call 888-758-7002 or send an email to service@sktelesys.com.

CDMA REPEATER



Contact Information

Maker	
Korea Office Address	SK Telesys Co., Ltd 12-13F, Naewei Bldg.6, Eulgiro-2Ga, Jung-Gu, Seoul 100-844, Korea Homepage: www.sktelesys.com
US Office Address	SK Telesys Corp. 12750 center court drive suite #400, Cerritos, CA 90703
Staff in charge of sales	Kap Soo, Park, Director Phone: 562-207-1924, Fax: 562-207-1925 Email: kapspark@sktelesys.com
Service contact in US	Email : service@sktelesys.com Phone: 888-758-7002
Staff in charge of R&D	Jae-Hyung Kim, Manager Phone: 82-31-786-5625, Email: kjhyung@sktelesys.com