

CUSTOMER APPROVAL SHEET

Company Name	SOLUM
MODEL	EL022D2
CUSTOMER APPROVAL	
FCC ID	2AFWN-EL022D2

- APPROVAL FOR SPECIFICATIONS ONLY (Spec. Ver. 1.1)
- CUSTOMER REMARK :

Issued By	Checked By	Approved By
YJ Kim	TH Lee	BJJun

SOLUM CO.,LTD.

A-6th floor, 357, Guseong-ro, Giheung-gu, Yongin-si, Gyeonggi-do 16674, Korea

Tel: +82-31-8006-7691

S-Label Datasheet

S-Label (Electronic Shelf Label System)

REV 1.1

SoluM

2018-08-13

Summary

This datasheet presents the general performance and specifications of S-Label for ESL (Electronic Shelf Label) system

© 2018SoluM. All rights reserved

The names of actual companies and products mentioned herein may be the trademarks of their respective owners.

No part of this document may be reproduced, stored in a retrieval system, or transmitted in any form or by any means without the express written consent of SoluM

This document is subject to change without notice.

Table of Contents

1	GENERAL DESCRIPTION	5
1.1	FEATURES	6
1.2	TYPICAL APPLICATIONS	6
1.3	APPEARANCE	6
2	SPECIFICATION	7
2.1	PRODUCT SPECIFICATION	7
2.2	RADIO (RF) SPECIFICATION	8
2.3	NFC SPECIFICATION	8
2.4	MECHANICAL DRAWING.....	9
2.5	LABELS	12
3	PACKAGE	14
4	CAUTIONS FOR TREATMENT	16
4.1	USAGE ENVIRONMENT	16
4.2	STORAGE AND USE	16
4.3	BATTERY REPLACEMENT	19
4.4	HOW TO CLEANING	20

Document History

Rev.	Date	Revision history	Page
1.0	22JUN 2018	Initial release	-
1.1	13 Aug 2018	Add EU& 7.5"/11.6"	

1 General Description

This S-Label product is a part of SOLUM S-Label (Electronic Shelf Label) system as well as S-Label Gateway (S-Gate). S-Label system make up a system that electronically displays price and other product information on S-Labels, which has been traditionally printed or written on paper in places like retail markets.

S-Label receives product price/information updates from S-Gate and updates or changes its display of price and other information.

S-Label is the product based on IEEE standard 802.15.4g for low power wireless communication applications. S-Label consists of RF transceiver, RF circuitry and ARM Cortex M3 MCU offering IEEE 802.15.4g based network protocol and MAC protocol and other peripheral devices.

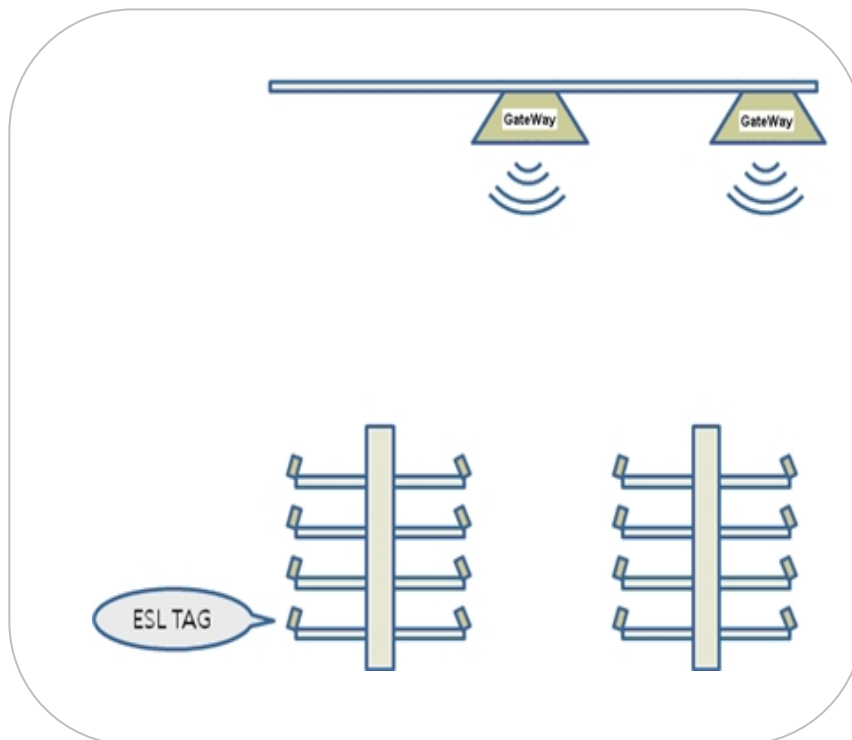

Figure 1ESL System

1.1 Features

- Display : E-Paper Display (EPD) (active type) (1.6",2.2",2.9",4.2",7.5",11.6")
- Display Color : Mono type (Black, White), Red color type (Black, White, Red),
Communication : Wireless communication based on IEEE 802.15.4g
- Operating on 860 ~ 920MHz Unlicensed ISM band for ZigBee
- Low Power Consumption
- Working condition: Indoor where wireless communication is available.
- NFC(13.56MHz) : Optional

1.2 Typical Applications

- Retail industry with electronic displays, platforms, solutions and services.
- Intelligently communicating, managing, and optimizing price and product informations.

1.3 Appearance

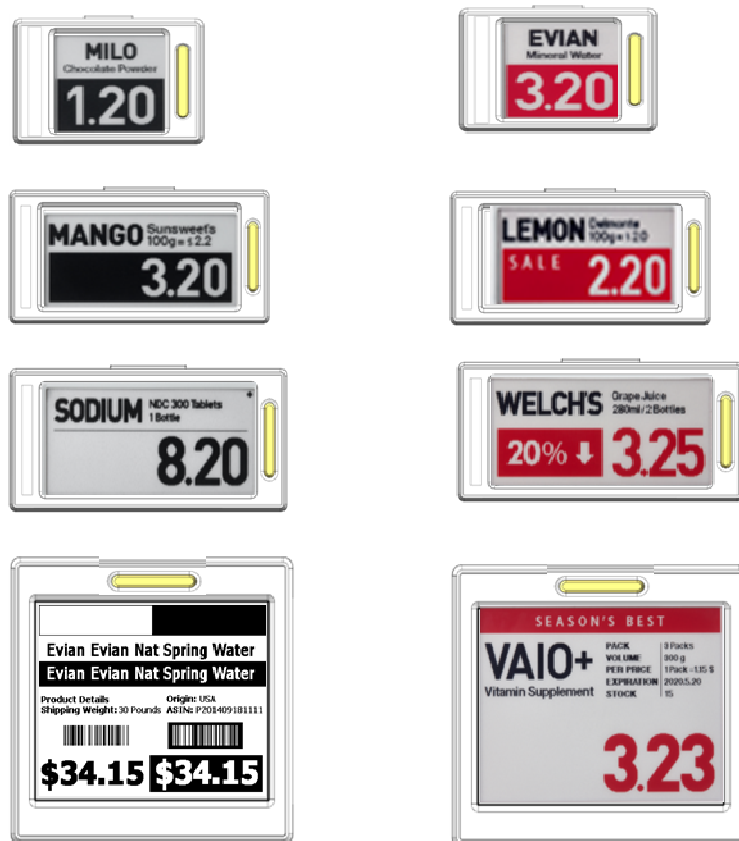

Figure 2.S-Label Appearance

2 Specification

2.1 Product Specification

Item	Description
Size	1.6 Inch: 48.55 x 36.25 x 11.95 mm 2.2 Inch: 69.40 x 36.20 x 11.65 mm 2.9 Inch: 91.2 X 41.12 X 11.88mm 4.2 Inch: 103.50 X 92.67 X 14.50mm
Battery	CR2450 Lithium Battery (3V, 1~4PCS) 2.4 ~ 3.3Vdc (condition : In active status) - CR2450 2pcs : 2.2", 2.9" 4.2" - ** Note: Battery capacity depends on temperature
Display	EPD PANEL Display (Graphic type) - Mono: White / Black (BW) - RedColor: White / Black / Red (BWR) 1.6 Inch: 200 x 200 Pixel (184dpi) / 27.60 x 27.60 mm – Mono 152 x 152 Pixel (140dpi) / 27.51 x 27.51 mm – Color 2.2 Inch: 212 x 104 Pixel (111dpi) / 47.76 x 22.92 mm 2.9 Inch: 296 x 128 Pixel (112dpi) / 66.90 x 29.06 mm 4.2 Inch: 400 x 300 Pixel (120dpi) / 84.40 x 63.30 mm
Housing Color	White (Option; Black)
Information display	Price, Unit, Symbol etc.
Communication	Wireless communication based on IEEE 802.15.4g (USA 902~928Mhz, EU 863~870)
Communication Distance	Radius 30m (Line of Sight)
Operation Temperature (Mono Tag)	Normal Temperature TAG 0 ~ 40°C (@20~60% RH)
Operation Temperature	Normal Temperature TAG

(Color Tag)	0 ~ 30°C (@35~60% RH)
Storage Temp.	-20°C ~ 40°C

2.2 Radio(RF) Specification

Items	Parameter	Spec.			Unit	Condition
		Min	Typ.	Max		
TX	Transmit Power	5	10	15	dBm	
	Modulation Quality Deviation	70	.	130	%	70% < f < 130% @2FSK
	Tx Current	-	-	16	mA	Total current at max Tx power
RX	Receiver Sensitivity	-90			dBm	PER < 1%

** Test Channel : 865 MHz (EU), 902 Mhz(US)

2.3 NFC Specification

Items	Parameter	spec.			Units	Condition
		Min	Typ	Max		
NFC	Read Distance	-	20	-	mm	TAG status

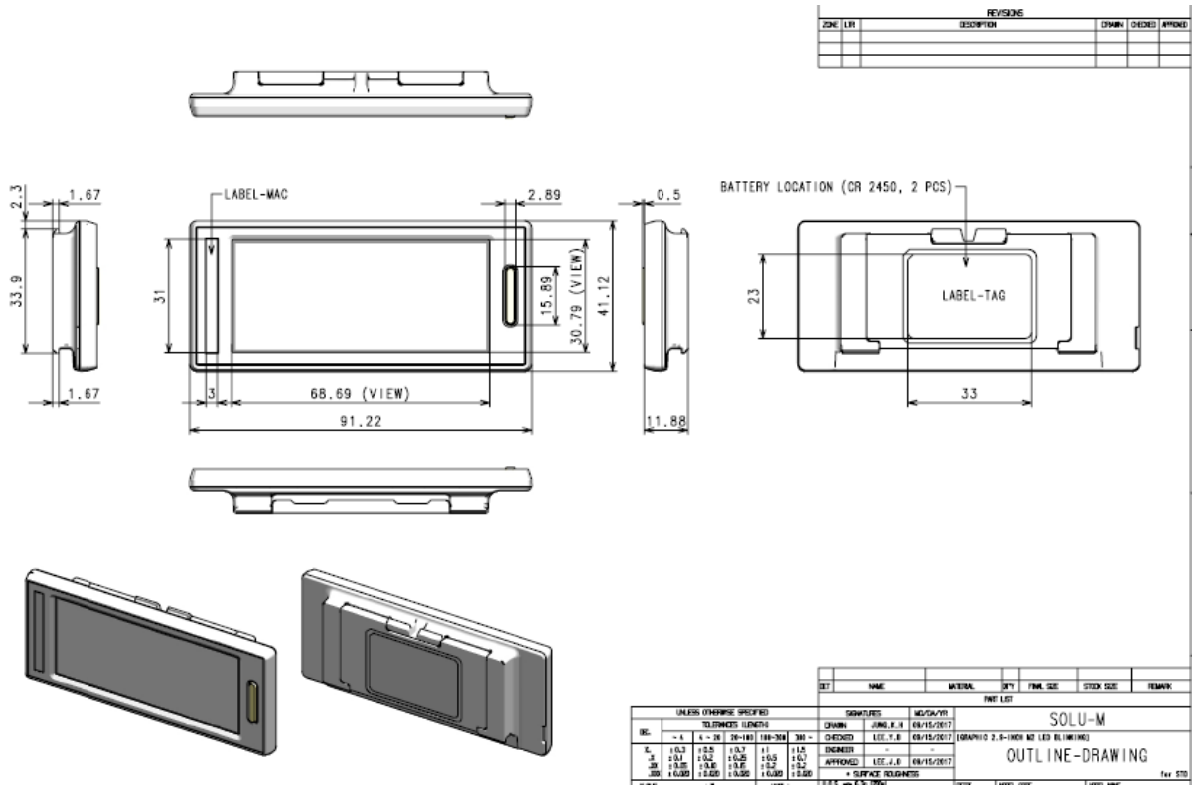

Figure 5. 2.9"Mechanical Dimension

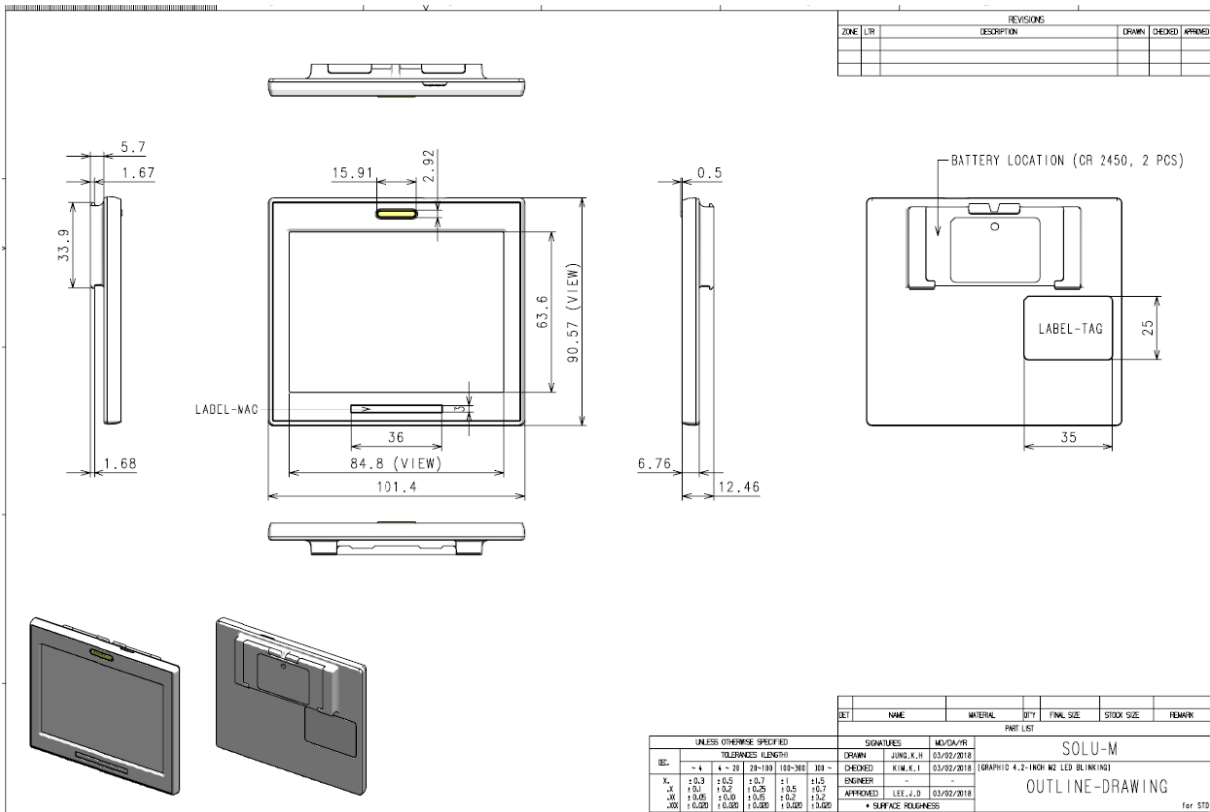

Figure 6. 4.2"Mechanical Dimension

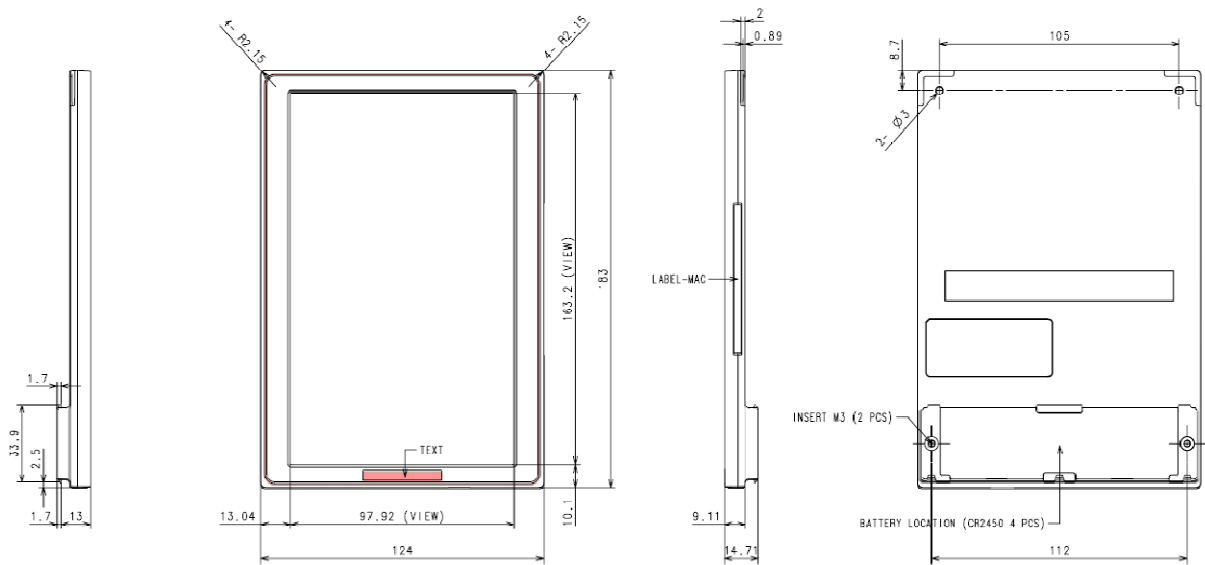

Figure 6.7.4"Mechanical Dimension

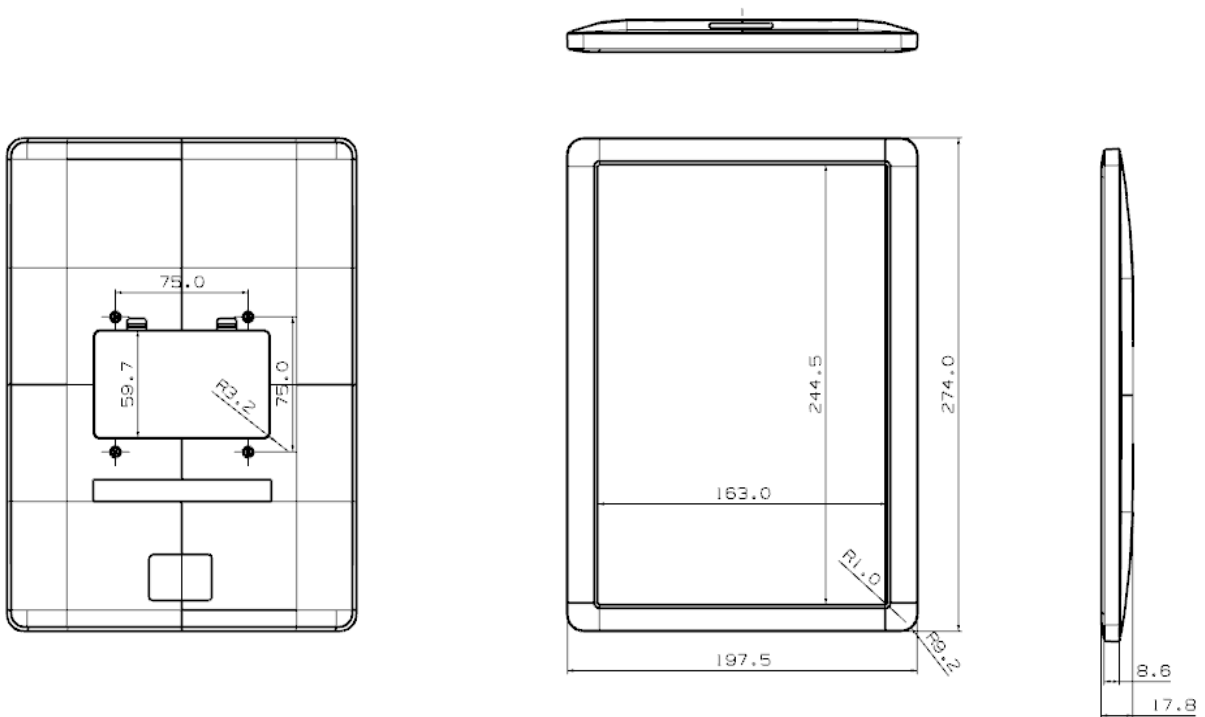

Figure 6.11.6"Mechanical Dimension

2.5 Labels

2.5.1 Serial Number Information

Serial 1, 2 Code Value

17	3	G	T	A	A	2JW
①	②	③	④	⑤	⑥	⑦

- ① Year : Last two digits of manufacturing year.
(00 ~ 99, Example : 2017 is '17')
- ② Month : Manufacturing month
(1 ~ 9, X(10), Y(11), Z(12))
- ③ Date : Manufacturing date
(1 ~ 9, A(10) ~ V(31))
- ④ Vendor : Manufacturing vendor
(S : SEMTHAI, T : TSEM, V : SOLVINA , etc)
- ⑤ Line number : Manufacturing Line number
('A', 'B', 'C', etc)
- ⑥ Revision : Product revision number
(A : First, B : Second, C : Third, etc)
- ⑦ ZigBee IC Lot Number : Last 3 characters
Product and Mac Label Drawings

①

년	CODE
2009	09
2010	10
2011	11
2012	12
2013	13
2014	14
2015	15
2016	16
2017	17
2018	18
2019	19
2020	20
2021	21
2022	22

②

월	CODE
1	1
2	2
3	3
4	4
5	5
6	6
7	7
8	8
9	9
10	X
11	Y
12	Z

③

일	CODE
1	1
2	2
3	3
4	4
5	5
6	6
7	7
8	8
9	9
10	A
11	B
12	C
13	D
14	E
15	F
16	G
17	H
18	I
19	J
20	K
21	L
22	M
23	N
24	O
25	P
26	Q
27	R
28	S
29	T
30	U
31	V

2.5.2 MAC Label

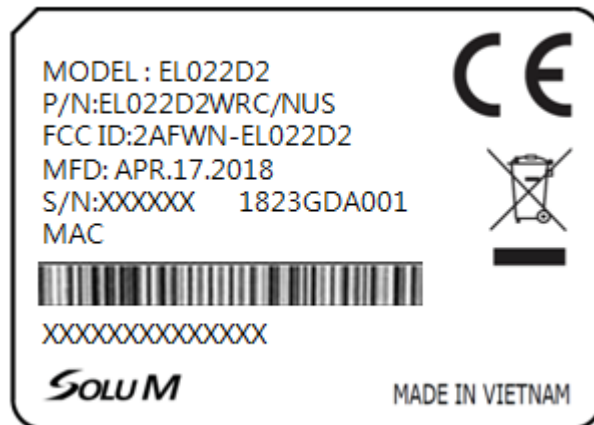

Figure 7 Product and Mac Labels

Product information is indicated in a printed sticker label. The information consists of MODEL (model name), MFD (manufacturing date), S/N (serial number), MAC (MAC address), CE certification mark, FCC ID and Manufacture (SOLUM).

- 1) Model : ELOXXD2 (XX:Tag Display size (29; 2.9") (42,4.2"))
- 2) P/N: EL0①②③④⑤⑥⑦ex ; EL029D2WRC/NUS
- 3) FCC ID: 2AFWN-EL0XXD2 (XX:Tag Display size (29; 2.9") (42,4.2"))
- 4) MFD : (month).(date).(year) ex) APR.17.2017
- 5) S/N : Daily Production Quantity (6 digits) & Serial Number Information
(hexadecimal 10 digits)
- 6) MAC : barcode & barcode number (hexadecimal 12 digits)
ex) XXXXXXXXB23X
 - 8 digits(1st ~ 8th) : XXXXXXXX (Increasing number : 00000000 ~ FFFFFFFF)
 - 2 digit(9th ~ 10th) : B2 (TAG type, B2 : TI SUB &2.4GHz 2.9inch RED TAG)
 - 1 digit(11th) : 3 (Attribute : 3 (Ultachip Drive IC & NFC)
 - 1 digit(12th) : X (Checksum : XOR Calculation Value 1 ~ 13digits)

Model Name : EL0①②③④⑤⑥⑦⑧⑨⑩⑪⑫⑬ ex ; /NUSor /EEU or /KKR

- EL : Electronic Shelf Label
- ①②: Tag Display size (29; 2.9") (42,4.2")
- ③ :Design type-④ : CASE COLOR
- ⑤ : Display color
 - M - Mono Tag (BW)
 - R - Red color Tag (BWR)
- ⑥ FunctionN : NFC / C : LED+NFC /A : LED+Button+NFC
- ⑦ /Region NUS (North USA) EEU (EU) KKR (South Korea)

3 Package

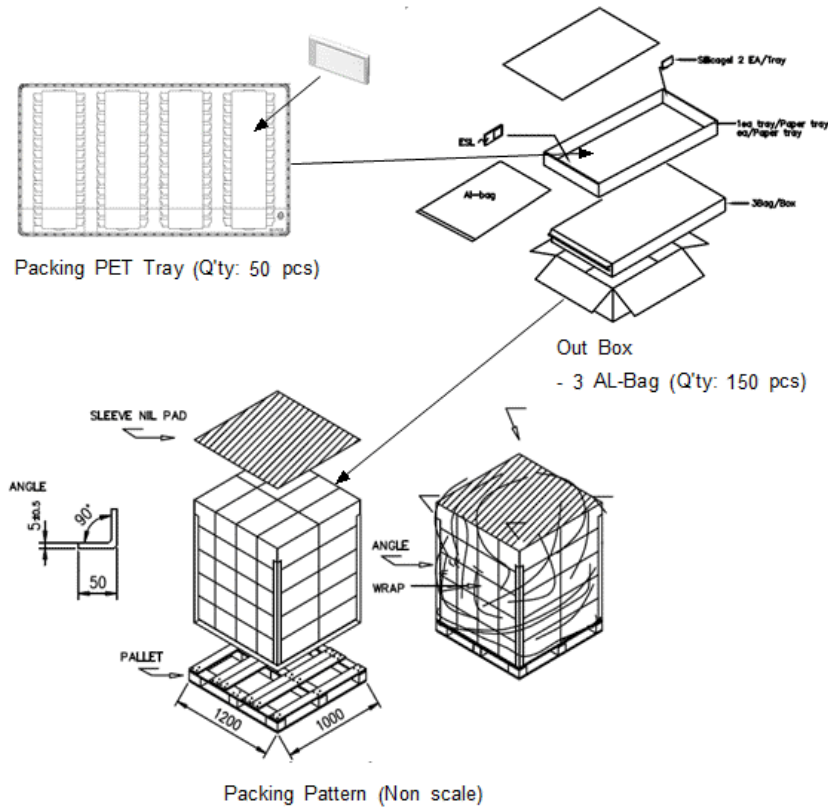

TAG	INNER BOX	OUT- BOX	PALLET
1.6"	90	270	10,800
2.2"	60	180	7,200
2.9"	50	150	6,000
4.2"	40	80	3,200
7.5"	25	50	2,000
11.6"	1	8	320

Figure 8 2.9" Package



Figure 9 Packing Label

4 Cautions for Treatment

Provisions should be made to protect against any damage to the product caused by improper handling.

It is highly recommended that the product should be installed within 3 months from the date of arrival in the logistics hub. Recommended storage condition is in 0-40 Celsius degree, 35-60% RH environment.

This RF device operates on the under 1GHz frequency band and can produce radio interference. The device, therefore, may not be used for applications where safety of human lives is concerned.

4.1 Usage Environment

Take extra cautions when using this RF device in the vicinity of other electronic devices and appliances. Most electronic devices and appliances use electromagnetic waves. Electromagnetic waves emitted by this RF device can affect other electronic devices and appliances.

If using the device in an explosion hazard area, follow all safety regulations, instructions, and signals.

4.2 Storage and Use

- Moisture and liquids can damage internal parts and circuit boards if allowed to enter into the device itself.
- Do not place or store the product on a sloped surface. The product may slide and fall off the surface and damaged.
- Use the product in temperatures ranging from 0°C to +40°C. Parts and circuits may be damaged if used or stored under temperature extremes.
- The display panel needs extra care when handling.
 - Do not apply any impacts on outside since e-Paper display is fragile.
 - Continuous exposure to excessive moisture (over 60% RH) or UV makes display lifetime shortened.
 - Ghosting image may be appeared in temperature conditions of less than 15 Celsius degree.
- Avoid areas with strong magnetism or subject to magnetism.
Contact between the device and a magnetic object can lead to malfunctions.
- Do not place the product near heat-producing kitchen appliances like a stove or a microwave or in the vicinity of highly pressurized containers.
- External impact to the product, such as from being dropped, can damage the product or battery casing can be separated.
- Twisting and bending the product can damage the exterior casing and the internal components.

SOLUM S-Label Datasheet (EL000D2WRC/NUS)

- If this product operates abnormally in eliminating battery vinyl or replacing battery, you should discharge it by contacting battery terminal (+) and (-).
- This product uses Sub giga frequency frequency band for wireless communication network. Radio communications can be limited or affected by other applications which share same frequency band, such as RFID, Wireless Phone, etc.
- Frequent communications, updates and screen renewals may reduce battery life time.
- In cold area, may reduce battery life time.

FCC

This device complies with part 15 of the FCC Rules. Operation is subject to the following two conditions:

- (1) This device may not cause harmful interference, and
- (2) This device must accept any interference received, including interference that may cause undesired operation.

- FCC Information to User

This equipment has been tested and found to comply with the limits for a Class B digital device, pursuant to Part 15 of the FCC Rules. These limits are designed to provide reasonable protection against harmful interference in a residential installation. This equipment generates, uses and can radiate radio frequency energy and, if not installed and used in accordance with the instructions, may cause harmful interference to radio communications. However, there is no guarantee that interference will not occur in a particular installation. If this equipment does cause harmful interference to radio or television reception, which can be determined by turning the equipment off and on, the user is encouraged to try to correct the interference by one of the following measures:

- Reorient or relocate the receiving antenna.
- Increase the separation between the equipment and receiver.
- Connect the equipment into an outlet on a circuit different from that to which the receiver is connected.
- Consult the dealer or an experienced radio/TV technician for help.

Caution

THE GRANTEE IS NOT RESPONSIBLE FOR ANY CHANGES OR MODIFICATIONS NOT EXPRESSLY APPROVED BY THE PARTY RESPONSIBLE FOR COMPLIANCE. SUCH MODIFICATIONS COULD VOID THE USER'S AUTHORITY TO OPERATE THE EQUIPMENT

4.3 Battery Replacement

Audience

Authorized persons with the following knowledge are allowed to replace the battery.

- . Battery / -. Electronic assemblies like circuit board / -. Compliance of the instruction

※ Note : If not authorized person, it will not give any warranty.

(When need to replace the battery. Please contact authorized person and get instructions.)

Instructions

- Risk of short circuit if battery is incorrectly installed/stored.
- Keep attention that your hands are dry before you start with replacement
- Keep away batteries from children and infants.
- Don't heat, charge, bend, drop, short-circuit and disassemble battery.
- Don't mix the used battery together with the new battery or different type of batteries.

※ Note : Battery rarely has a little stain or leak.

Steps

- ① Open the battery cover.
- ② Take out the batteries.
- ③ Put in the new batteries.
- ④ Check the batteries direction.
- ⑤ Put the battery cover back.

Battery Directional

Top: (+) Positive

Bottom: (-) Negative

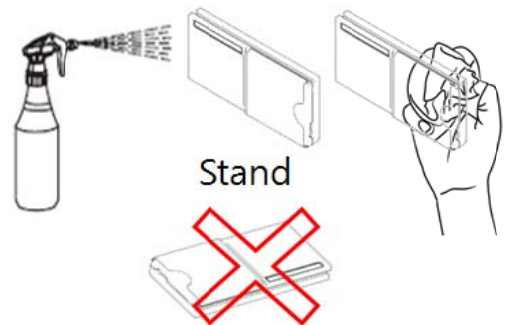

Figure 21. Battery Directional

4.4 How to cleaning

For Spray Cleaning:

- Stand labels not to lay down labels
- Lightly spray to the surfaces and wait few second
- Clean wipe it using cloth or tissues.
- Dry out labels



Note:

- When spray the tags, make sure not to flow any liquid into inside labels
- It may damage labels directly, circuit and battery.
- You can use mild, non-alcoholic detergents or glass cleaner.
- Recommend non-abrasive cloths: Microfiber, Cotton T-shirt, Cotton handkerchief, Cotton tea towel

For Wet Tissue Cleaning:

- Lay down tags or stand labels
- Wipe using wet tissues
- Dry out labels



We do not guarantee any water damaged labels

