

PRODUCT DATASHEET

Company Name	
MODEL	EL116C2WRN/WWW
CUSTOMER APPROVAL	

□ **CUSTOMER REMARK :**

Issued By	Checked By	Approved By
JY Kim	JG Ryu	BJ Jun

Solu-M

150, Maeyoung-ro(Maetan-Dong), Youngtong-Gu, Suwon, Gyunggi-Do, Korea
Tel : 82-31-210-3494

S-TAG Datasheet

S-Label (Electronic Label System)

REV 1.0

Solu-M

2018-05-18

Summary

This datasheet presents the general performance and specifications of S-Tag for S-Label ESL (Electronic Shelf Label) system, which is based on IEEE 802.15.4.

© 2015 Solu-M. All rights reserved

The names of actual companies and products mentioned herein may be the trademarks of their respective owners.

No part of this document may be reproduced, stored in a retrieval system, or transmitted in any form or by any means without the express written consent of Solu-M.

This document is subject to change without notice.

Table of Contents

1	GENERAL DESCRIPTION	5
1.1	FEATURES	6
1.2	TYPICAL APPLICATIONS.....	6
2	SPECIFICATION	7
2.1	PRODUCT SPECIFICATION	7
2.2	RADIO (RF) SPECIFICATION (TBD)	7
2.3	NFC SPECIFICATION.....	8
2.4	MECHANICAL DRAWING	8
2.5	LABELS.....	9
3	OPERATION TEST	11
4	ESL OPERATION BY DISPLAY	12
5	PACKAGE	13
6	CAUTIONS FOR TREATMENT	14
6.1	USAGE ENVIRONMENT	14
6.2	STORAGE AND USE	14
6.3	BATTERY REPLACEMENT	15

Document History

Rev.	Date	Revision history	Page
1.0	18 May 2018	Initial release	-

1 General Description

This S-Tag product is a part of Solu-M S-Label (Electronic Shelf Label) system as well as S-Label Gateway (S-Gate), Remote controller (S-RC). S-Label system make up a system that electronically displays price and other product information on S-Tags, which has been traditionally printed or written on paper in places like retail markets.

S-Tag receives product price/information updates from S-Gate and updates or changes its display of price and other information.

S-Tag is the product based on IEEE standard 802.15.4 for low power wireless communication applications. S-Tag consists of RF transceiver, RF circuitry and 8051-compatible MCU offering IEEE 802.15.4 based network protocol and MAC protocol and other peripheral devices.

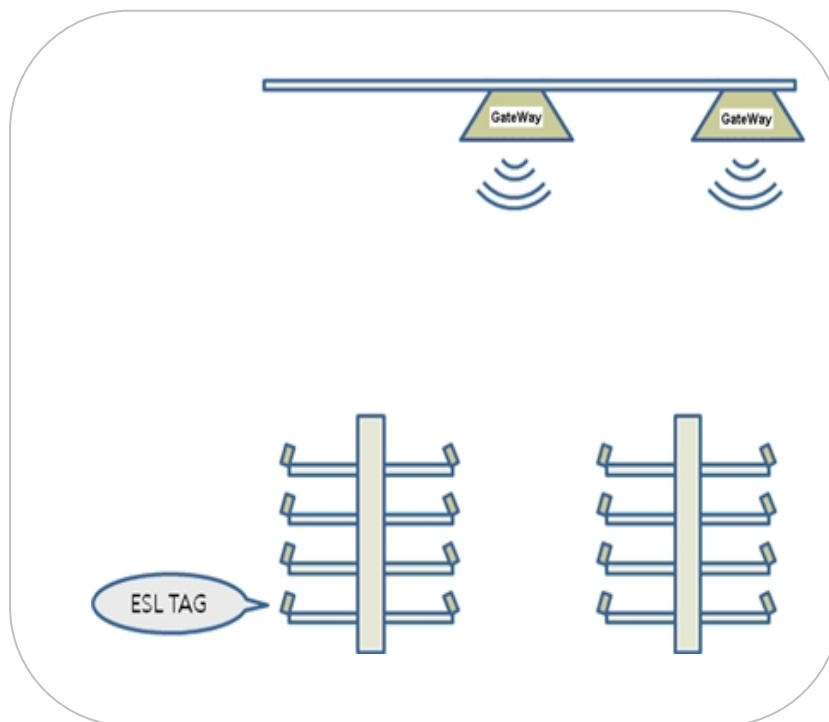

Figure 1. S-Label System

1.1 Features

- Display : E-Paper Display (EPD) (active type) (640 mm x 960 mm) (Red)
- Communication : Wireless communication based on IEEE 802.15.4
- Operating on 2.4GHz Unlicensed ISM band for ZigBee
- Low Power Consumption
- External Wakeup : RF Wakeup (using ISM Band(2.4GHz))
- Outline Dimension : 197.5 mm x 274.0 mm x 17.8 mm
- Case Color : White
- Working condition: Indoor where wireless communication is available.

1.2 Typical Applications

- Retail industry with electronic displays, platforms, solutions and services.
- Intelligently communicating, managing, and optimizing price and product information.

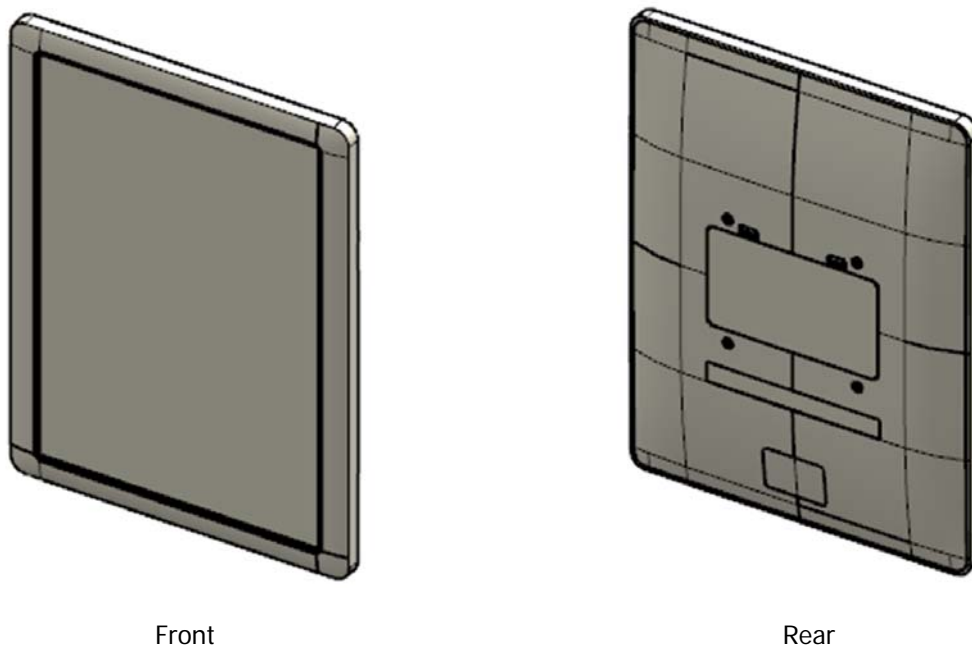

Figure 2. Appearance

2 Specification

2.1 Product Specification

Item	Description
Size	197.5 mm x 274.0 mm x 17.8 mm
Battery	Li-Fe Battery AAA (3V-4EA) 2.5 ~ 3.3Vdc (condition : In active status)
Display	Electrical paper display (Outline : 254.31 X 176.35 mm) (Red) (Resolution : 640(V) x 960(H) /100 dpi)
Housing Color	White
Information display	Price, Unit, Symbol etc.
Communication	Wireless communication based on IEEE 802.15.4
Communication Distance	Radius 20m (Line of Sight)
Operation Temp.	0 ~ 30 °C (@35~70% RH)
Etc.	No additional anti-theft locking structure : Rail Mounted only

2.2 Radio (RF)¹ Specification

Item	Parameter	SPEC			Unit	Condition
		Min	Typ	Max		
TX	Transmit Power	-5	0	8	dBm	
	Error Vector Magnitude		10	30	%	When measured for 100 chips
	Tx Current			10	mA	Total current at max Tx Power
RX	Receiver Sensitivity	-70	-	-	dBm	PER < 1%

¹ Test Channel : 2480MHz

2.3 NFC Specification

Items	Parameter	spec.			Units	Condition
		Min	Typ	Max		
NFC	Read/Write Distance	-	40	-	mm	PCB status
NFC	Read/Write Distance	-	30	-	mm	Final Assy status

2.4 Mechanical Drawing

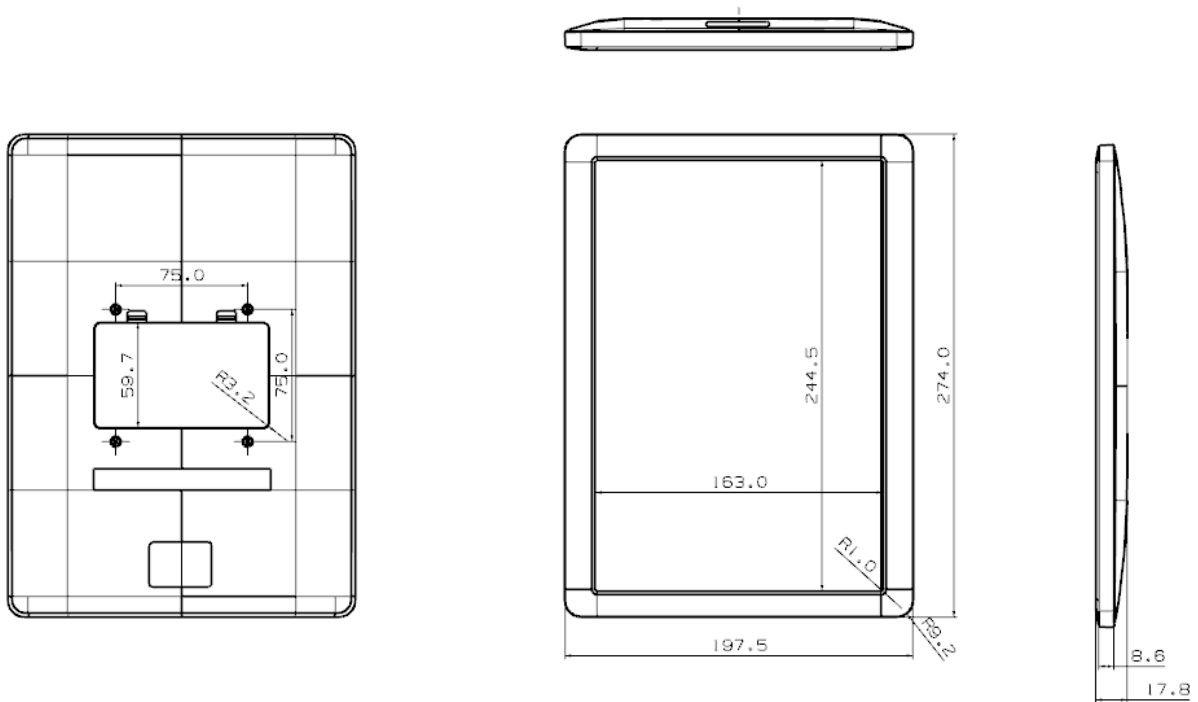

Figure 3. Mechanical Dimension

2.5 Labels

2.5.1 Code Information

Serial 1, 2 Code Value

15	Y	5	S	A	A	2JW
①	②	③	④	⑤	⑥	⑦

① Year : Last two digits of manufacturing year.

(00 ~ 99, Example : 2015 is '15')

② Month : Manufacturing month

(1 ~ 9, X(10), Y(11), Z(12))

③ Date : Manufacturing date

(1 ~ 9, A(10) ~ V(31))

④ Vendor : Manufacturing vendor

(D : Dongguan Solu-M, V : Solu-M Vina., T : TSEM,..... etc)

⑤ Line number : Manufacturing Line number

('A', 'B', 'C', etc)

⑥ Revision : Product revision number

(A : First, B : Second, C : Third, etc.)

⑦ ZigBee IC Lot Number : Last 3 characters of Lot Number

(Example : YME06862JW is '2JW')

①

년	CODE
2009	09
2010	10
2011	11
2012	12
2013	13
2014	14
2015	15
2016	16
2017	17
2018	18
2019	19
2020	20
2021	21
2022	22

②

월	CODE
1	1
2	2
3	3
4	4
5	5
6	6
7	7
8	8
9	9
10	X
11	Y
12	Z

③

일	CODE
1	1
2	2
3	3
4	4
5	5
6	6
7	7
8	8
9	9
10	A
11	B
12	C
13	D
14	E
15	F
16	G
17	H
18	I
19	J
20	K
21	L
22	M
23	N
24	O
25	P
26	Q
27	R
28	S
29	T
30	U
31	V

2.5.2 Mac Label Drawings



Figure 2. Mac Labels

Product information is indicated in a printed sticker label. The information consists of MODEL (model name), MFD (manufacturing date), S/N (serial number), MAC (MAC address), certification mark, and Manufacture.

- 1) TYPE : EL116C2
- 2) FCC ID : 2AFWN-EL116C2
- 3) Model Name : EL116C2WRN/WWW
- 4) MFD : (Month).(Date).(Year) ex) MAY.17.2018
- 5) MAC : barcode & barcode number(hexadecimal 14 digits)
 - 8 digits(1st ~ 8th) : XXXXXXXX (Extension ID)
 - 2 digits(9th ~ 10th) : BD (Tag size and type)
 - 1 digit(11th) : 7 (Univeral Protocol, Ultachip Drive IC & NFC)
 - 1 digit(12th) : 0 ~ F (Checksum)

This device complies with part 15 of the FCC Rules. Operation is subject to the following two conditions:

- (1) This device may not cause harmful interference, and
- (2) this device must accept any interference received, including interference that may cause undesired operation.

3 Operation Test

Equipments : GateWay(S-Gate), Jig for power supply

Target DUT : EPD Tag

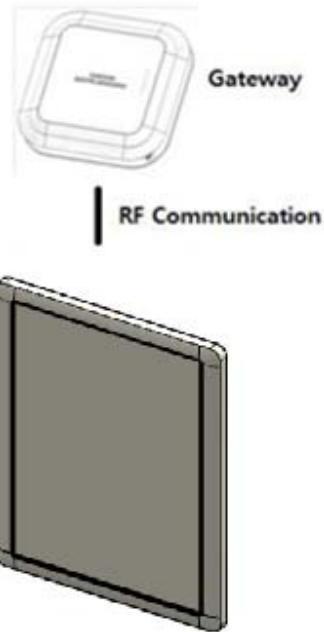

Test Scenario

- ① Install Tag on Jig
- ② Ready to Gateway(S-Gate)
- ③ Tag start to communicate with Gateway
- ④ Tag display the image received from Gateway and enter to sleep mode.
(Display pattern : MAC → SCAN Icon → MAC)
- ⑤ Wake up Tag with R/C
- ⑥ Check Tag (Display pattern : SCAN Icon → MAC)
- ⑦ Get off Tag from Jig.

Criterion (Below condition should be satisfied)

- ① Good : You can see a MAC in White display.

4 ESL Operation by display

TBD

5 Package

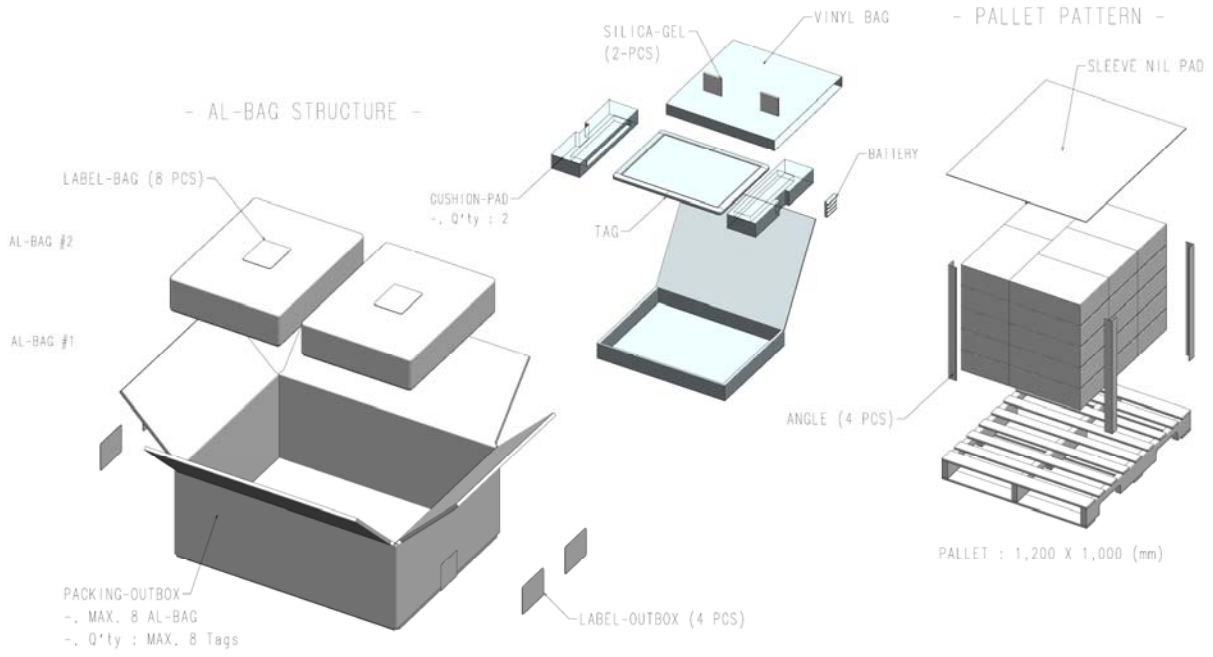

6 Cautions for Treatment

Provisions should be made to protect against any damage to the product caused by improper handling.

It is highly recommended that the product should be installed within 3 months from the date of arrival in the logistics hub. Recommended storage condition is in -20 ~ 60 Celsius degree, 35-70% RH environment.

This RF device operates on the 2.4GHz frequency band and can produce radio interference. The device, therefore, may not be used for applications where safety of human lives is concerned.

6.1 Usage Environment

Take extra cautions when using this RF device in the vicinity of other electronic devices and appliances. Most electronic devices and appliances use electromagnetic waves. Electromagnetic waves emitted by this RF device can affect other electronic devices and appliances.

If using the device in an explosion hazard area, follow all safety regulations, instructions, and signals.

6.2 Storage and Use

- Moisture and liquids can damage internal parts and circuit boards if allowed to enter into the device itself.
- Do not place or store the product on a sloped surface. The product may slide and fall off the surface and damaged.
- Use the product in temperatures ranging from 10°C to +40°C. Parts and circuits may be damaged if used or stored under temperature extremes.
- The display panel needs extra care when handling.
 - Do not apply any impacts on outside since e-Paper display is fragile.
 - Continuous exposure to excessive moisture (over 70% RH) or UV makes display lifetime shortened.
 - Ghosting image may be appeared in temperature conditions of less than 15 Celsius degree.
- Avoid areas with strong magnetism or subject to magnetism. Contact between the device and a magnetic object can lead to malfunctions.
- Do not place the product near heat-producing kitchen appliances like a stove or a microwave or in the vicinity of highly pressurized containers.

- External impact to the product, such as from being dropped, can damage the product or battery casing can be separated.
- Twisting and bending the product can damage the exterior casing and the internal components.
- If this product operates abnormally in eliminating battery vinyl or replacing battery, you should discharge it by contacting battery terminal (+) and (-).
- This product uses 2.4GHz frequency band for wireless communication network. Radio communications can be limited or affected by other applications which share same frequency band, such as Wi-Fi, Bluetooth, ZigBee, etc.
- Frequent communications, updates and screen renewals may reduce battery life time.

6.3 Battery Replacement

6.3.1 Audience

Authorized persons with the following knowledge are allowed to replace the battery.

- Battery
 - Electronic assemblies like circuit board
 - Compliance of the instruction
- ※ Note : If not authorized person, it will not give any warranty.

6.3.2 Instructions

- Risk of explosion through incorrect battery replacement.
 - Keep attention that your hands are dry before you start with replacement.
 - When replace the battery, please contact right person and get a instructions.
- ※ Note : Battery rarely has a little stain or leak.

6.3.3 Steps

1. Open the battery cover.
2. Take out the batteries.
3. Put in the new batteries.
4. Check the batteries direction.
5. Put the battery cover.

WARNING :

FCC Information to User

This equipment has been tested and found to comply with the limits for a Class B digital device, pursuant to Part 15 of the FCC Rules. These limits are designed to provide reasonable protection against harmful interference in a residential installation. This equipment generates, uses and can radiate radio frequency energy and, if not installed and used in accordance with the instructions, may cause harmful interference to radio communications. However, there is no guarantee that interference will not occur in a particular installation. If this equipment does cause harmful interference to radio or television reception, which can be determined by turning the equipment off and on, the user is encouraged to try to correct the interference by one of the following measures:

- Reorient or relocate the receiving antenna.
- Increase the separation between the equipment and receiver.
- Connect the equipment into an outlet on a circuit different from that to which the receiver is connected.
- Consult the dealer or an experienced radio/TV technician for help.

Caution

THE GRANTEE IS NOT RESPONSIBLE FOR ANY CHANGES OR MODIFICATIONS NOT EXPRESSLY APPROVED BY THE PARTY RESPONSIBLE FOR COMPLIANCE. SUCH MODIFICATIONS COULD VOID THE USER'S AUTHORITY TO OPERATE THE EQUIPMENT.

IMPORTANT NOTE : FCC RF Radiation Exposure Statement

This equipment complies with FCC RF radiation exposure limits set forth for an uncontrolled environment. This equipment should be installed and operated with a minimum distance of 20 centimeters between the radiator and your body. This transmitter must not be co-located or operating in conjunction with any other antenna or transmitter.