

DATASHEET

| | |
|--------------------------|-----------------------|
| Company Name | Macy's |
| MODEL | ELS10AFWM0/NUS |
| CUSTOMER APPROVAL | |

- APPROVAL FOR SPECIFICATIONS ONLY (Spec. Ver. 1.0)**
- CUSTOMER REMARK:**

| Issued By | Checked By | Approved By |
|------------------|-------------------|--------------------|
| WY HUR | HJ CHO | BJ Jun |

SOLUM CO., LTD.

A-6th floor, 357, Guseong-ro, Giheung-gu, Yongin-si, Gyeonggi-do 16674, Korea
Tel: +82-31-8006-7691

S-Label Datasheet

S-Label (Electronic Label System)

REV 1.0

Solu-M

2017-12-19

Summary

This datasheet presents the general performance and specifications of S-Label for ESL (Electronic Shelf Label) System.

© 2017 Solu-M. All rights reserved

The names of actual companies and products mentioned herein may be the trademarks of their respective owners.

No part of this document may be reproduced, stored in a retrieval system, or transmitted in any form or by any means without the express written consent of Solu-M

This document is subject to change without notice.

Table of Contents

| | | |
|----------|---------------------------------------|-----------|
| 1 | GENERAL DESCRIPTION..... | 5 |
| 1.1 | FEATURES | 6 |
| 1.2 | TYPICAL APPLICATIONS..... | 6 |
| 1.3 | APPEARANCE | 7 |
| 2 | SPECIFICATION | 8 |
| 2.1 | PRODUCT SPECIFICATION | 8 |
| 2.2 | RADIO (RF) SPECIFICATION..... | 9 |
| 2.3 | MECHANICAL DRAWING | 10 |
| 2.4 | LABEL MARKING..... | 12 |
| 2.5 | BARCODE SCANNING | 14 |
| 3 | OPERATION TEST..... | 15 |
| 4 | ESL OPERATION BY DISPLAY | 17 |
| 5 | PACKAGING | 19 |
| 6 | CAUTIONS FOR TREATMENT..... | 20 |
| 6.1 | USAGE ENVIRONMENT | 20 |
| 6.2 | STORAGE AND USE | 20 |
| 6.3 | BATTERY REPLACEMENT | 21 |
| 6.4 | FCC | 23 |
| 6.5 | CLEANING | 24 |

Document History

| Rev. | Date | Revision History | Page |
|-------------|-------------|-------------------------|-------------|
| 1.0 | 19 Dec 2017 | Initial release | - |
| | | | |
| | | | |
| | | | |

1 General Description

S-Label product is part of SoluM S-Label (Electronic Shelf Label) System, also consisting of S-Label Gateway (S-Gate), and Remote Controller (S-RC). The S-Label System electronically displays price, product, and promotion information on S-Labels, which has been traditionally printed or written on paper in places such as retail markets.

S-Label wirelessly receives data from S-Gate and updates the display with the new information provided.

S-Label is based on IEEE standard 802.15.4 for low power wireless communication applications. It consists of RF transceiver, RF circuitry and ARM Cortex M3 MCU offering IEEE 802.15.4 based network protocol, and MAC protocol and other peripheral devices.

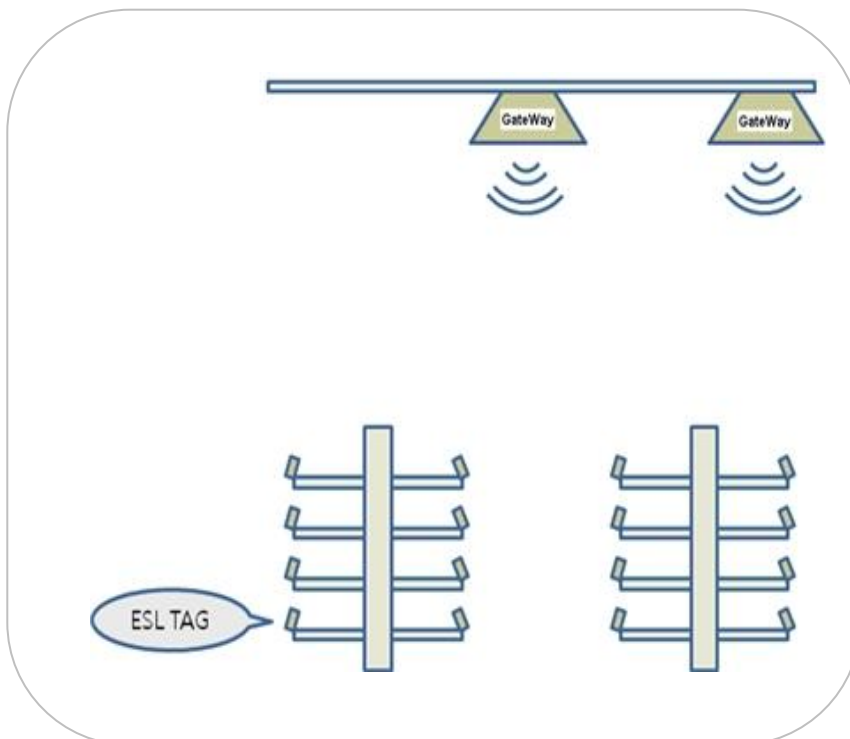

Figure 1. ESL System

1.1 Features

- Display: E-Paper Display (EPD) 7seg. Type (1.0" – 19.51 x 19.51mm)
- Display Color: Black, White
- Communication: Wireless communication based on IEEE 802.15.4
- Operating on 2.4GHz Unlicensed ISM band for ZigBee
- Low Power Consumption
- External Wakeup: RF Wakeup (using ISM Band [2.4GHz])
- Case Color : White & Red
- Working Condition: Indoor where wireless communication is available.

1.2 Typical Applications

- Retail industry with electronic displays, platforms, solutions and services.
- Intelligently communicating, managing, and optimizing price and product informations.

1.3 Appearance



Figure 2. Appearance

2 Specification

2.1 Product Specification

| Item | Description |
|------------------------|---|
| Size | 1.24 x 3.31 x 0.23(Label) / 0.76inch(with clip) 31.6 x 84.09 x 5.9(Label) / 19.21mm(with clip) |
| Weight | 17g |
| Battery | CR2032 Lithium Battery (3V, 1PC) 2.4 ~ 3.3Vdc (condition: In active status) ** Note: Battery capacity depends on temperature (especially in low temp environment) and number of update count. |
| Display | EPD PANEL Display (7Seg. type) - Color: Black / White |
| Color | Housing ; White Silicon ; Red Clip ; Milky white |
| Information display | Prices, save rate etc. |
| Communication | Wireless communication based on IEEE 802.15.4 (2405~2480MHz) |
| Communication Distance | Radius 20m (Line of Sight) |
| Operation Temperature | 5 ~ 40 °C |
| Storage Temp. | -20 ~ 40 °C |
| Humidity | 35 ~ 60% RH |

2.2 Radio (RF) Specification

| Item | Parameter | SPEC | | | Unit | Condition |
|------|------------------------|------|-----|-----|------|-------------------------------|
| | | Min | Typ | Max | | |
| TX | Transmit Power | -4 | 1.5 | 6 | dBm | |
| | Error Vector Magnitude | - | 10 | 28 | % | When measured for 100 chips |
| | Tx Current | | - | 33 | mA | Total current at max Tx Power |
| RX | Receiver Sensitivity | -90 | - | - | dBm | PER < 1% |

** Test Channel: 2480MHz

2.3 Mechanical Drawing

2.3.1 Product Dimension

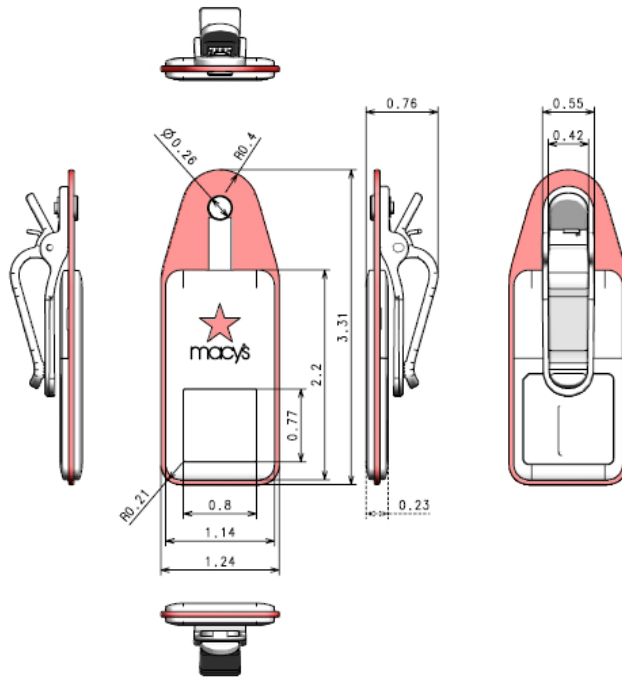

Figure 3. Mechanical Dimension (unit: inch)

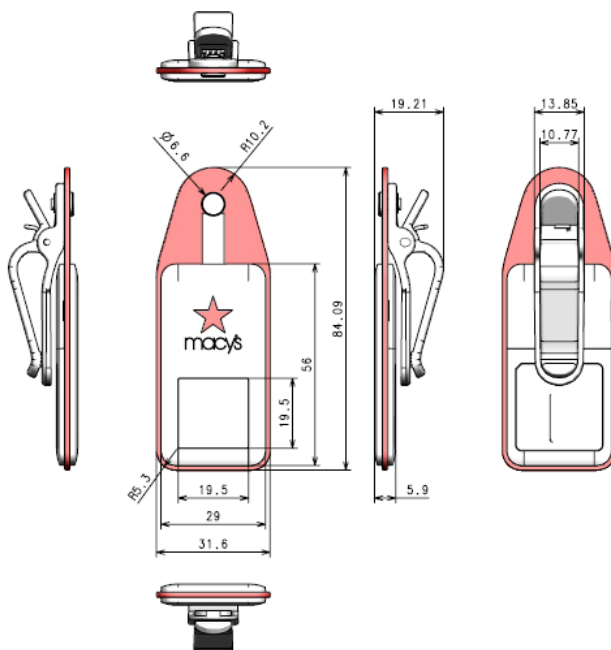

Figure 4. Mechanical Dimension (unit: mm)

2.3.2 Exploded View

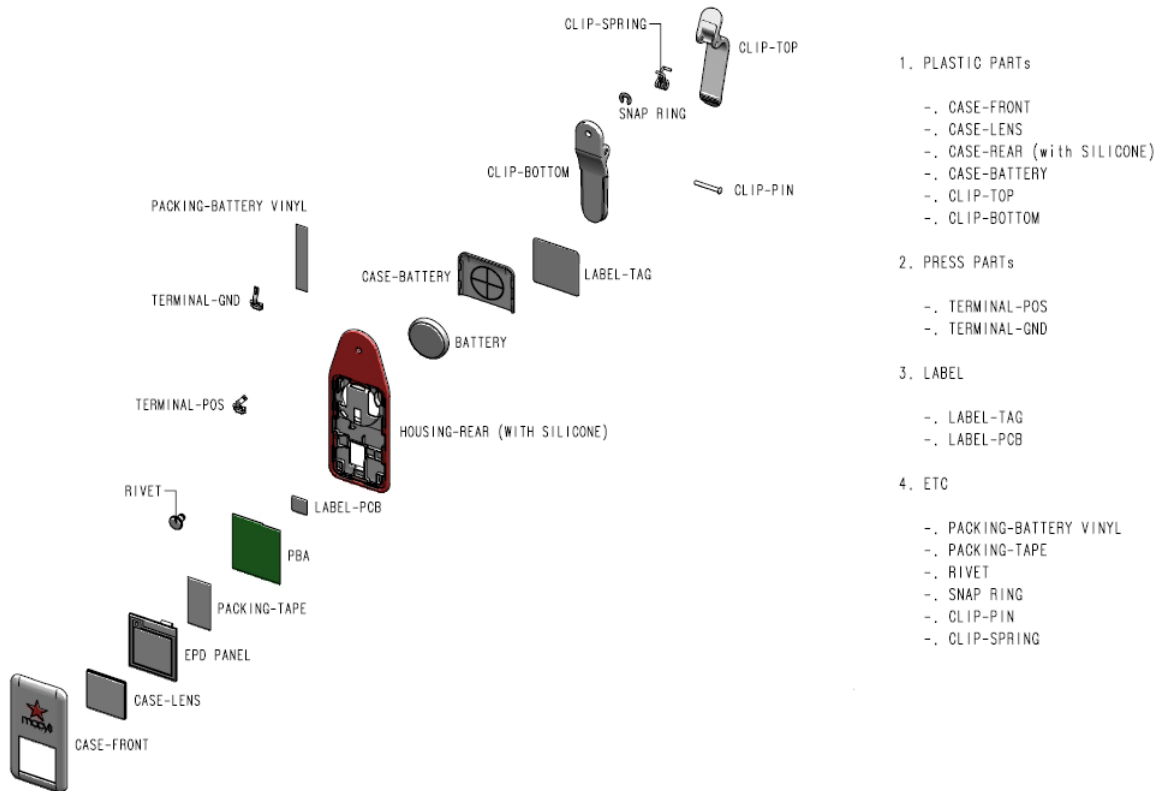

Figure 5. Exploded View

2.4 Label Marking

2.4.1 Serial Number Information

Serial 1, 2 Code Value

| | | | | | | |
|----|---|---|---|---|---|-----|
| 17 | 3 | G | T | A | A | 001 |
| ① | ② | ③ | ④ | ⑤ | ⑥ | ⑦ |

- ① Year: Last two digits of manufacturing year.
(00 ~ 99, Example: 2017 is '17')
- ② Month: Manufacturing month
(1 ~ 9, X(10), Y(11), Z(12))
- ③ Date: Manufacturing date
(1 ~ 9, A(10) ~ V(31))
- ④ Vendor: Manufacturing vendor
(S: SEMTHAI, T: TSEM, V: SOLVINA, etc)
- ⑤ Line number: Manufacturing Line number
('A', 'B', 'C', etc)
- ⑥ Revision: Product revision number
(A: First, B: Second, C: Third, etc)
- ⑦ ZigBee IC Lot Number: Last 3 characters
Product and Mac Label Drawings

①

| 년 | CODE |
|------|------|
| 2009 | 09 |
| 2010 | 10 |
| 2011 | 11 |
| 2012 | 12 |
| 2013 | 13 |
| 2014 | 14 |
| 2015 | 15 |
| 2016 | 16 |
| 2017 | 17 |
| 2018 | 18 |
| 2019 | 19 |
| 2020 | 20 |
| 2021 | 21 |
| 2022 | 22 |

②

| 월 | CODE |
|----|------|
| 1 | 1 |
| 2 | 2 |
| 3 | 3 |
| 4 | 4 |
| 5 | 5 |
| 6 | 6 |
| 7 | 7 |
| 8 | 8 |
| 9 | 9 |
| 10 | X |
| 11 | Y |
| 12 | Z |

③

| 일 | CODE |
|----|------|
| 1 | 1 |
| 2 | 2 |
| 3 | 3 |
| 4 | 4 |
| 5 | 5 |
| 6 | 6 |
| 7 | 7 |
| 8 | 8 |
| 9 | 9 |
| 10 | A |
| 11 | B |
| 12 | C |
| 13 | D |
| 14 | E |
| 15 | F |
| 16 | G |
| 17 | H |
| 18 | I |
| 19 | J |
| 20 | K |
| 21 | L |
| 22 | M |
| 23 | N |
| 24 | O |
| 25 | P |
| 26 | Q |
| 27 | R |
| 28 | S |
| 29 | T |
| 30 | U |
| 31 | V |

* The six digit number in the start of the serial line is the daily quantity manufacturing count.

2.4.2

2.4.3 MAC Label

Product Label

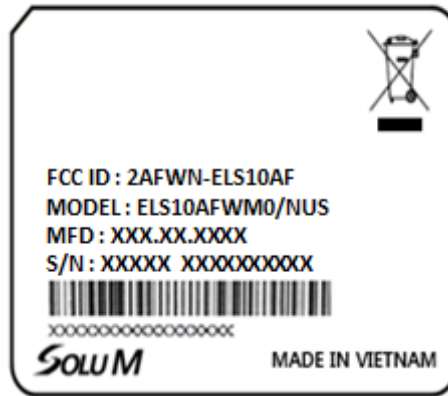

Figure 6. Product Label

Product information is indicated on the sticker label of the S-Labels. The information consists of MODEL (model name), MFD (manufacturing date), S/N (serial number), MAC (MAC address), CE certification mark, FCC ID and Manufacturer (SoluM).

- 1) FCC ID: T.B.D
- 2) Model Name: ELS10AFWM0/NUS
- 3) MFD: (Month).(Date).(Year) i.e. Dec.19.2017
- 4) S/N: Serial Number Information (See Section 2.5.1)
- 5) MAC: barcode & barcode number (hexadecimal 12 digits)
 - 8 digits (1st ~ 8th) : xxxxxxxx (Label I.D.)
 - 3 digits (9th ~ 11th) : 041 (Label type)
 - 1 digit (12th) : x (Checksum)

2.5 Barcode Scanning

2.5.1 Barcode Scanning Condition

Typical scan distance is 8 ~ 9cm and angle is horizontality.

| Item | MODEL | Distance | Angle |
|---------|------------------------------|----------|------------|
| Scanner | SYMBOL (DS6708-SR20007ZZR) | 8~9cm | Horizontal |
| | DATALOGIC (QUICKSCAN QD2430) | 8~9cm | Horizontal |
| | Motorola (MC3190-SI2H04E0A) | 8~9cm | Horizontal |
| PDA | Motorola (MC17T-00) | 6cm | 30° |
| | Motorola (MC4597-BAPBA0000) | 8~9cm | Horizontal |
| | M3 (NA8NWCNMH40078) | 8~9cm | Horizontal |

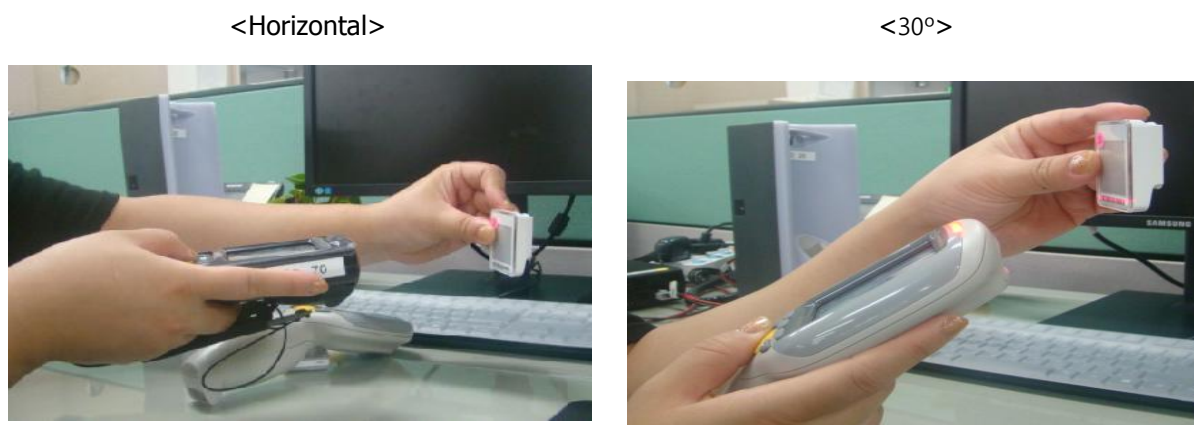

Figure 7. Barcode Scanning

3 Operation Test

- Equipment: Gateway (S-Gate), R/C, Jig for power supply
- Target DUT: EPD S-Label

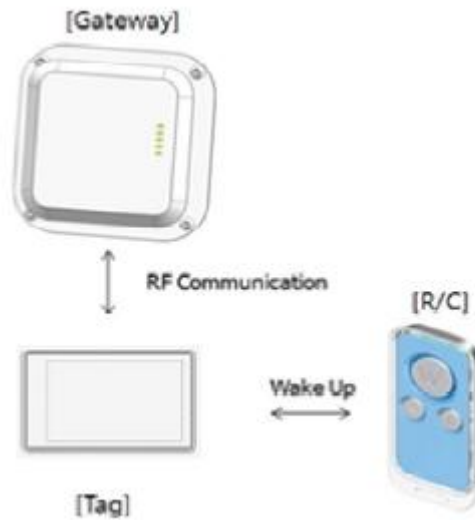

Figure 8. Operation Test

Test Scenario

- ① Install Tag on Jig
- ② Ready Gateway (S-Gate) and R/C
- ③ Wake up Tag with R/C
- ④ Tag starts to communicate with Gateway
- ⑤ Tag display the numeric information received from Gateway
- ⑥ Check Tag (EPD display status & MAC address value)
- ⑦ Wake up Tag with R/C
- ⑧ Check Tag (EPD display [blank display])

Criteria (Both conditions below should be satisfied)

- ① Good: You can see 'Black' → 'White' display
- ② Compare MAC Address displayed with the MAC Address on the S-Tag label itself

Position of Activation for S-Label

RED BOX: R/C Wake-up



Figure 9. Position of Activation for S-Label

4 ESL Operation by Display

Table will be updated. Below is sample reference.

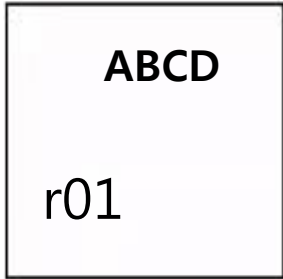
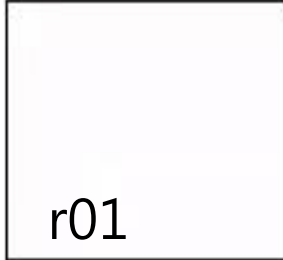
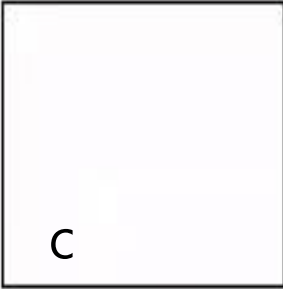
| Display | State | User Action |
|---|---|-----------------------|
|  | Initial display when shipped from the manufacturer (blank display). | None |
|  | Display Revision and MAC-Address | Battery vinyl removal |
|  | Sync search | None |
|  | STATE 2 → 4 Activation received | None |

| | | |
|---|---------------------|-------------------------------|
| <div style="border: 1px solid black; padding: 10px; text-align: center;"> <p>123.12</p> <p>SAVE 10 %</p> <p>110.11</p> </div> | Price received | |
| <div style="border: 1px solid black; height: 100px; width: 100%;"></div> | Un-assign | Un-assign S-Label using a PDA |
| <div style="border: 1px solid black; padding: 10px; text-align: center;"> <p>123.12</p> <p>SAVE 10 %</p> <p>--- --</p> </div> | Sale price overflow | None |
| <div style="border: 1px solid black; padding: 10px; text-align: center;"> <p>--- --</p> <p>SAVE 10 %</p> <p>110.11</p> </div> | Unit price overflow | None |

5 Packaging

PACKING-DIAGRAM

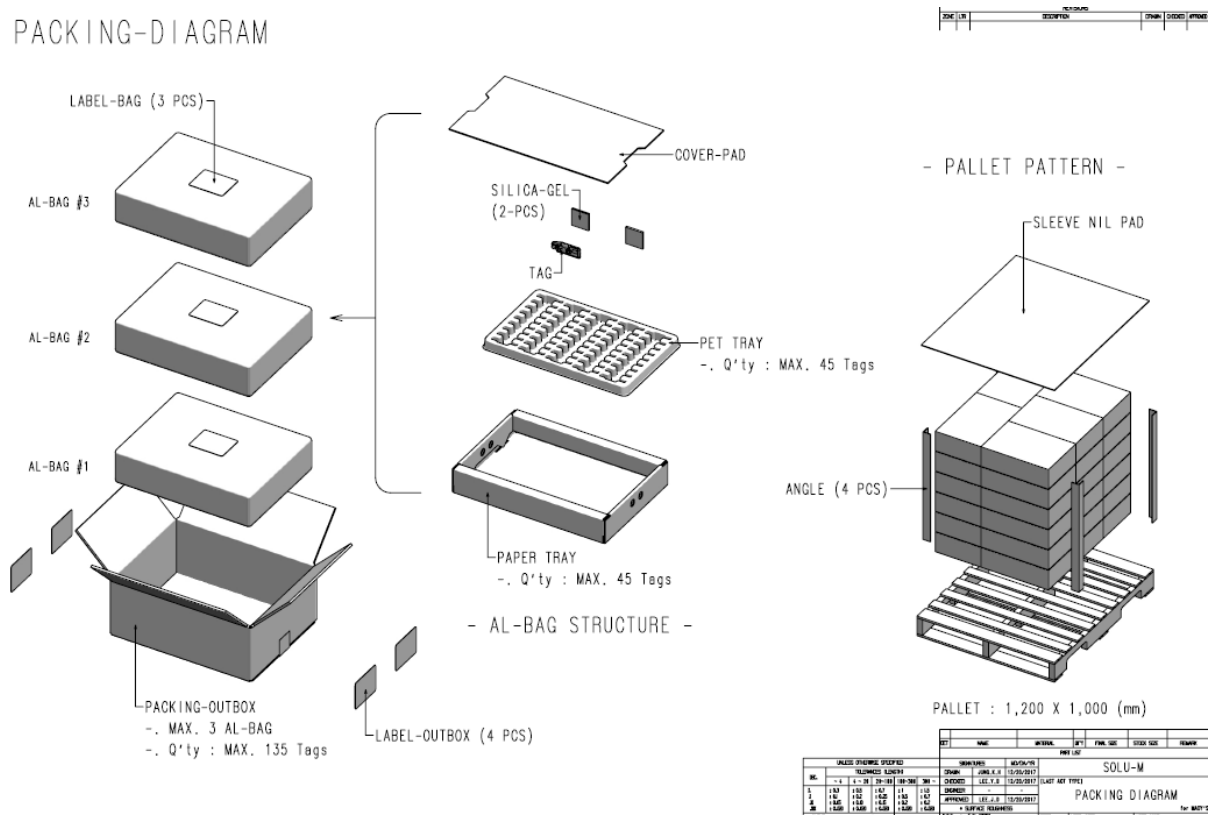

Figure 10. Package



Figure 11. Packing Label

6 Cautions for Treatment

Provisions should be made to protect against any damage to the product caused by improper handling. The purchaser assumes any responsibility for damage to the product caused by improper handling.

It is highly recommended that the product should be installed within 3 months from the date of arrival in the logistics hub. Recommended storage condition is -20~40 Celsius degree, 35-60% RH environment.

6.1 Usage Environment

Take extra cautions when using this RF device in the vicinity of other electronic devices and appliances. Most electronic devices and appliances use electromagnetic waves. Electromagnetic waves emitted by this RF device can affect other electronic devices and appliances.

If using the device in an explosion hazard area, follow all safety regulations, instructions, and signals.

6.2 Storage and Use

- Moisture and liquids can damage internal parts and circuit boards if allowed to enter into the device itself.
- Do not place or store the product on a sloped surface. The product may slide and fall off the surface and damaged.
- Use the product in temperatures ranging from 5°C to +40°C. Parts and circuits may be damaged if operating or stored in extreme temperature.
- The display panel needs extra care when handling.
 - Do not apply any impacts on the e-Paper display as it is fragile.
 - Continuous exposure to excessive moisture (over 60% RH) or UV shortens display lifetime.
 - Ghosting image may appear in temperature conditions of less than 15 Celsius degree.
- Avoid areas with strong magnetism or subject to magnetism.
Contact between the device and a magnetic object can lead to malfunctions.
- Do not place the product near heat-producing kitchen appliances like a stove or a microwave or in the vicinity of highly pressurized containers.
- External impact to the product, such as from being dropped, can damage the product.
- Twisting and bending the product can damage the exterior casing and the internal components.
- If this product operates abnormally while removing battery or replacing battery, the product

should be discharged by contacting the battery terminals (+) and (-) in the product.

- This product uses 2.4GHz frequency band for wireless communication network. Radio communications can be limited or affected by other applications that share the same frequency band, such as WiFi, Bluetooth, Zigbee, etc.
- Frequent communications, updates and screen renewals may reduce battery life time.
- Low temperature environments may reduce battery life.

6.3 Battery Replacement

Audience

- Authorized persons with the following knowledge are allowed to replace the battery:

Battery / Electronic assemblies like circuit board / Compliance of the instruction

- ※ Note: Warranty is voided if battery is replacement by unauthorized personnel.

(When replacing batteries, please contact authorized person)

Instructions

- Risk of short circuit if battery is incorrectly installed/stored.
- Check that your hands are dry before and at all times during the replacement process.
- Keep batteries away from children and infants.
- Do not heat, charge, bend, drop, short-circuit and/or disassemble battery.
- Do not mix used and new battery together or different battery types.
- ※ Note: Battery rarely has minor stain or leak.

Steps

- ① Open the battery cover.
- ② Take out the batteries.
- ③ Put in the new batteries.
- ④ Check the batteries direction.
- ⑤ Put the battery cover back.

Battery Directional

Top: (+) Positive
Bottom: (-) Negative



Battery (CR2032) : 

Figure 12. Battery Directional

6.4 FCC

WARNING: This equipment may generate or use radio frequency energy. Changes or modifications to this equipment may cause harmful interference unless the modifications are expressly approved in the instruction manual. The user could lose the authority to operate this equipment if an unauthorized change or modification is made.

⌋. THE GRANTEE IS NOT RESPONSIBLE FOR ANY CHANGES OR MODIFICATIONS NOT EXPRESSLY APPROVED BY THE PARTY RESPONSIBLE FOR COMPLIANCE.

SUCH MODIFICATIONS COULD VOID THE USER'S AUTHORITY TO OPERATE THE EQUIPMENT.

⌋. This device complies with part 15 of the FCC Rules. Operation is subject to the following two conditions:

- (1) This device may not cause harmful interference, and
- (2) this device must accept any interference received, including interference that may cause undesired operation.

NOTE: This equipment has been tested and found to comply with the limits for a Class B digital device, pursuant to part 15 of the FCC Rules. These limits are designed to provide reasonable protection against harmful interference in a residential installation. This equipment generates, uses and can radiate radio frequency energy and, if not installed and used in accordance with the instructions, may cause harmful interference to radio communications. However, there is no guarantee that interference will not occur in a particular installation. If this equipment does cause harmful interference to radio or television reception, which can be determined by turning the equipment off and on, the user is encouraged to try to correct the interference by one or more of the following measures:

- Reorient or relocate the receiving antenna.
- Increase the separation between the equipment and receiver.
- Connect the equipment into an outlet on a circuit different from that to which the receiver is connected.
- Consult the dealer or an experienced radio/TV technician for help.

6.5 Cleaning

For Spray Cleaning:

Steps

- ① Stand labels. Do not lay the labels flat down.
- ② Lightly spray all surfaces and wait a few seconds.
- ③ Gentle wipe clean using a cloth or tissue.
- ④ Let the labels dry.

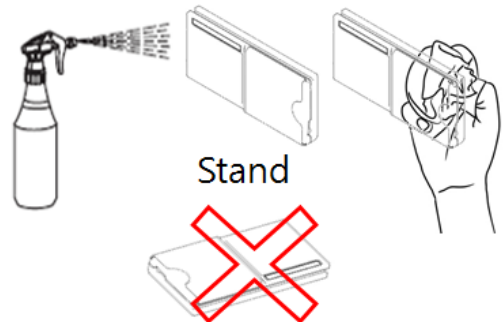

Notes:

- When spraying S-Labels, make sure no liquid flows inside the S-Label.
- Liquid contact to the inside of the S-label can damage circuitry and battery.
- Use mild, non-alcoholic detergents or glass cleaner.
- Recommend non-abrasive cloths: Microfiber, Cotton T-shirt, Cotton handkerchief, Cotton tea towel

For Wet Tissue Cleaning:

Steps

- ① Stand or lay down the S-Labels.
- ② Wipe using wet tissues.
- ③ Let the labels dry.



We do not guarantee any water damaged labels

