

SMDR-NH124

Installation and Operation Manual



Document Reference:

Version:	V1.0
Document Status:	Release 1
Issue Date:	Jan. 02, 2009
Author:	Kyung Eun Han
Department:	R&D Division Team 1
Authorizing Manager:	Youngshin Yeo

REVISION HISTORY

Version	Issue Date	No. of Pages	Initials	Details of Revision Changes
V 1.0	Jan. 02, 2009		Original	
V 2.0	Oct. 23. 2009			Additional RDU(VHF+UHF)

Technical Support

SOLiD serial numbers must be available to authorize technical support and/or to establish a return authorization for defective units. The serial numbers are located on the back of the unit, as well as on the box in which they were delivered. Additional support information may be obtained by accessing the SOLiD Tehcnology, Inc. website at www.st.co.kr or send email at sjkim@st.co.kr

This manual is produced by Global Business Division Business Team 1. Printed in Korea.

Contents

Section1	<i>Safety & Certification Notice</i>	8
Section2	<i>System Overview</i>	10
	2.1 General overview	11
	2.2 System overview	12
Section3	<i>System Specifications</i>	14
	3.1 System specifications	15
	3.1.1 Physical Specifications	15
	3.1.2 Optic wavelength and Laser power.....	16
	3.1.3 Environmental specifications	16
	3.1.4 Operating Frequencies range	16
	3.1.5 Specifications Per band	17
Section4	<i>System Configuration and Functions</i>	22
	4.1 BIU (BTS Interface Unit)	22
	4.1.1 Specifications of BIU	22
	4.1.2 Block diagram of BIU.....	23
	4.1.3 BIU parts	23
	4.1.4 Function by unit.....	24
	4.1.5 Front/rear panels of BIU	28
	4.2 ODU (Optic distribution Unit).....	30
	4.2.1 Specifications of ODU	31
	4.2.2 Block Diagram of ODU	31
	4.2.3 ODU parts	32
	4.2.4 Function by unit.....	33
	4.2.5 Front/rear panels of MHU	34
	4.2.6 Interface with BIU	35
	4.3 OEU (Optic Expansion Unit).....	36
	4.3.1 Specifications of OEU	37
	4.3.2 Block Diagram of OEU.....	37
	4.3.3 OEU parts	37
	4.3.4 Function by unit.....	38
	4.3.5 Front/rear panels of OEU	42
	4.4 ROU (Remote Optic Unit)	43

4.4.1	Specifications of ROU	43
4.4.2	Block Diagram of ROU	44
4.4.3	ROU parts	44
4.4.4	Function by unit.....	46
4.4.5	Bottom of ROU	50
Section5	System Installation & Operation.....	52
5.1	BIU Installation	53
5.1.1	BIU Shelf Installation	53
5.1.2	BIU Power Cabling.....	54
5.1.3	RF Interface at BIU.....	55
5.1.4	MDBU insertion.....	59
5.1.5	ODU Interface	60
5.1.6	Consumption Power of BIU	62
5.2	ODU Installation	63
5.2.1	ODU Shelf Installation	63
5.2.2	ODU Power Cabling.....	63
5.2.3	ODU Optic Cabling.....	63
5.2.4	Insert DOU to ODU.....	64
5.2.5	Consumption Power of ODU.....	65
5.3	ROU Installation	65
5.3.1	ROU Enclosure installation.....	65
5.3.2	ROU Power Cabling.....	65
5.3.3	Optical Cabling	65
5.3.4	Insertion of RDU.....	65
5.3.5	Consumption of RDU.....	65
5.4	OEU Installation	65
5.4.1	OEU Shelf installation	65
5.4.2	OEU Power Cabling	65
5.4.3	OEU Optic Cabling.....	65
5.4.4	Insert DOU to OEU.....	65
5.4.5	Consumption Power of OEU.....	65
5.5	System Operation and Alarm Status	65
Section6	Operation.....	65
6.1	BIU Operation	65
6.1.1	BIU	65

6.1.2	TX Operation at BIU	65
6.1.3	RX Operation at BIU	65
6.1.4	Setting whether to use ROU/OEU at BIU	65
6.1.5	ODU Operation at BIU	65
6.2	ROU Operation	65
6.2.1	ROU Operation	65

Contents of Figure

Figure 2.1 – Basic system topology	12
Figure 2.2 – Expansion system topology.....	13
Figure 4.1 – BIU outer view	22
Figure 4.2 – BIU mounting diagram.....	23
Figure 4.3 – MDBU Outer Look	26
Figure 4.4 – MDBU Outer Look	26
Figure 4.5 – MCCU Outer Look	27
Figure 4.6 – MPSU Outer Look.....	28
Figure 4.7 – BIU front panel Outer Look.....	29
Figure 4.8 – Rear panel Outer Look.....	30
Figure 4.9 – ODU Outer Look	31
Figure 4.10 – ODU Inner Look.....	32
Figure 4.11 – MDBU Outer Look.....	33
Figure 4.12 – 2Way Divider Outer Look.....	33
Figure 4.13 – BIU front panel Outer Look.....	34
Figure 4.14 – Rear panel Outer Look.....	34
Figure 4.15 – Interface between MHU and ODU	35
Figure 4.16 – OEU Outer Look	36
Figure 4.17 – OEU Inner Look	38
Figure 4.18 – MDBU Outer Look	39
Figure 4.19 – EWDM Outer Look.....	39
Figure 4.20 – ECPU Outer Look	40
Figure 4.21 – ERFM Outer Look	40
Figure 4.22 – ERFM Outer Look	41
Figure 4.23 – OEU front panel Outer Look.....	42
Figure 4.24 – Rear panel Outer Look.....	42
Figure 4.25 – ROU Outer Look	43
Figure 4.26 – ROU Inner Look	44
Figure 4.27 – RDU Outer Look	47
Figure 4.28 – R OPTIC Outer Look.....	48
Figure 4.29 – RCPU Outer Look	49
Figure 4.30 – Multiplexer Outer Look	49
Figure 4.31 – RU Bottom Look	50
Figure 5.1 – RACK Installation	53

Figure 5.2 – 800PS BDA Interface using Circulator	58
Figure 5.3 – 800PS BDA Interface using Duplexer	59
Figure 5.4 – Optical cable of SC/ACP Type	64
Figure 5.5 – How to install ROU	65
Figure 5.6 – Dimension used to install ROU on the WALL	65
Figure 5.7 – Optical cable of SC/ACP Type	65

Section1

Safety & Certification Notice

“Only qualified personnel are allowed to handle this unit. Read and obey all the warning labels attached in this user manual”

Any personnel involved in installation, operation or service of the SOLiD Technology repeaters must understand and obey the following:

- Obey all general and regional installation and safety regulations relating to work on high voltage installations, as well as regulations covering correct use of tools and personal protective equipment.
- The power supply unit in repeaters contains dangerous voltage level, which can cause electric shock. Switch the mains off prior to any work in such a repeater. Any local regulations are to be followed when servicing repeaters.
- The repeater cover should be (door) securely fastened in open position, e.g. by tying it up, at outdoor work in order to prevent door from slamming due to wind causing bodily harm or damage.
- Use this unit only for the purpose specified by the manufacturer. Do not carry out any modifications or fit any spare parts which are not sold or recommended by the manufacturer. This could cause fires, electric shock or other injuries.
- Any repeater, including this repeater, will generate radio signals and thereby give rise to electromagnetic fields that may be hazardous to the health of any person who is extensively exposed to the signals at the immediate proximity of the repeater and the repeater antennas.
- Due to power dissipation, repeater may reach a very high temperature. Do not operate this unit on or close to flammable materials.
- Do not use any solvents, chemicals, or cleaning solutions containing alcohol, ammonia, or abrasives.
- Certification
 - FCC: This equipment complies with the applicable sections of Title 47 CFR Parts 15,22,24 and 90
 - UL/CUL: This equipment complies with UL and CUL 1950-1 Standard for safety for information technology equipment,including electrical business equipment
 - FDA/CDRH: This equipment uses a Class 1 LASER according to FDA/CDRH Rules.This product conforms to all applicable standards of 21 CFR Chapter 1, Subchapter J, Part 1040

Section2

System Overview

2.1 General overview

2.2 System overview

2.1 General overview

SMDR-NH124 is a coverage system for in-building services delivering voice and data in high quality and for seamlessly.

As a distributed antenna system, it provides analog and digital phone systems that are served in multiple bands through one antenna.

The system covers general public institutions and private facilities.

- Shopping malls
- Hotels
- Campus areas
- Airports
- Clinics
- Subways
- Multi-use stadiums, convention centers, etc.

The system helps improve in-building radio environments in poor condition and make better poor RSSI and Ec/Io. By providing communication services at every corner of buildings, the system enables users to make a call at any site of buildings.

The system uses both analog (AMPS) and digital (TDMA, CDMA and WCDMA) methods.

The SMDR-NH124 system supports communication standards and public interface protocols in worldwide use.

- Frequencies: VHF,UHF, 700MHz, 800MHz,850MHz 900MHz,1900MHz,2100MHz, etc.
- Voice protocols: AMPS,TDMA, CDMA,GSM,IDEN, etc.
- Data protocols: EDGE,GPRS,WCDMA,CDMA2000,Paging, etc.

SMDR-NH124 is in modular structure per frequency. To provide desired frequency in a building, all you need to do is to insert a corresponding frequency module into each unit. As it delivers multiple signals with one optical cable, the system, in one-body type, does not require additional facilities whenever new frequency is added.

The system is featured with the following:

- Flexibilitiy & Scalabilitiy
 - Support fiber-optic ports up to 39
 - Clustering multiple-buildings (campus) as one coverage
- Modular structures
 - Modular frequency upgrade
 - Plug-in type module
- Multi-Band, Multi Operator

- Signals with a plurality of service provider transmit simultaneously
- Support multi-operator in a band
- Low OPEX / CAPEX
 - Compact design
 - Upgradable design
 - Easy installation and maintenance
 - Web Based SNMP or GSM Modem or UDP support (Optional)

2.2 System overview

SMDR-NH124 is composed of devices given below.

Basically, the system consists of BIU (BTS Interface Unit), ODU (Optic distribution Unit) and ROU (Remote Optic Unit). For addition of more ROUs, it has OEU (Optic Expansion Unit).

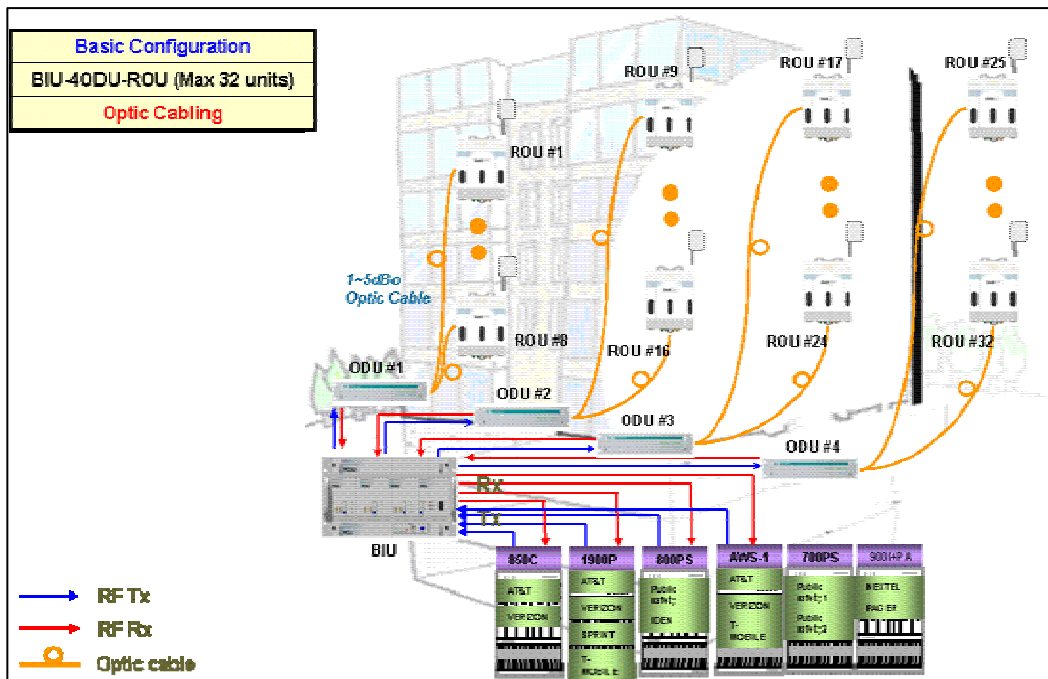

Figure 2.1 – Basic system topology

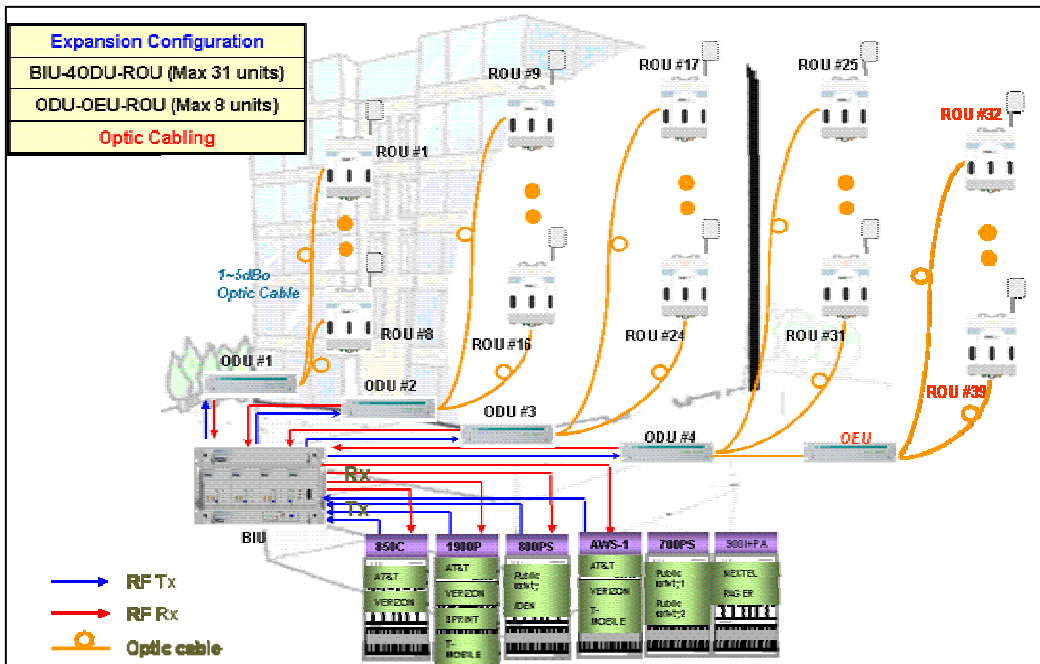

Figure 2.2 – Expansion system topology

Table 3.1 – System topology Charts

System elements	Optical Loss [dBo]	Max. RUs
BIU – ODU(DOUx1) – ROU	1~5dBo	4
BIU – ODU(DOUx2) – ROU	1~5dBo	8
BIU – 4ODU(DOUx2) – ROU	1~5dBo	32
BIU – 4ODU(DOUx2)-OEU(DOUx2) – ROU	1~5dBo	39

Section3

System Specifications

- 3.1 System specifications**
 - 3.1.1 Physical Specifications**
 - 3.1.2 Optic wavelength and Laser power**
 - 3.1.3 Environmental specifications**
 - 3.1.4 Operating Frequencies range**
 - 3.1.5 Specifications Per band**

3.1 System specifications

3.1.1 Physical Specifications

Parameter	BIU	ODU	OEU	ROU
RF Connectors	4 SMA type, female (Per MDBU)	2 SMA type, female	-	1N-type,female
External Alarm connector (Dry contacts)	Terminal block,3pcs	-	-	-
Serial Interface connector	1 RS-232 9-pin D-sub, male		1 RS-232 9-pin D-sub, male	1 RS-232 9-pin D-sub, male
Fiber connector	-	8pcs, SC/APC for ROU	1 SC/APC for ODU 8 SC/APC for ROU	1 SC/APC for ODU
LED Alarm and Status Indicator	MDBU Status <ul style="list-style-type: none"> ● Power On status ● ALM status MCPU <ul style="list-style-type: none"> ● Power On status ● TX Communication ● RX Communication ● ALM status MPSU <ul style="list-style-type: none"> ● Power On status ● DC ALM status 	DOU1 Status <ul style="list-style-type: none"> ● LD status ● PD1/2/3/4 status DOU2 Status <ul style="list-style-type: none"> ● LD status ● PD1/2/3/4 status 	EWDM Status <ul style="list-style-type: none"> ● LD status ● PD status DOU1 Status <ul style="list-style-type: none"> ● LD status ● PD1/2/3/4 status DOU2 Status <ul style="list-style-type: none"> ● LD status ● PD1/2/3/4 status System status <ul style="list-style-type: none"> ● Power on status ● TX Communication ● RX Communication 	System status <ul style="list-style-type: none"> ● Power on status ● TX1 Communication ● RX1 Communication ● TX2 Communication ● RX2 Communication ● ALM status
AC Power	-	-		Normal Range: 120VAC 50/60Hz Operating range 108~132VAC,50/60Hz
DC Power	Normal range: -48 VDC Operating range: -40.8 ~ -57.6VDC	-		Normal: -48 VDC Operating range: -40.8 ~ -57.6VDC
Power consumption	168W (Including ODU 4EA)	-	48W (Including DOU2EA)	265W (Including RDU 3EA)
Enclosure Dimensions	482.6(19") x 221.5(5U) x 450	482.6(19") x 43.6(1U) x 450	482.6(19") x 88.1(2U) x 450	420 x 530 x 258
Weight[Full Load]	22.25Kg	5.7Kg	9.3Kg	35.45Kg

3.1.2 Optic wavelength and Laser power

Parameter	ODU	OEU	ROU
Wavelength	TX: 1310nm RX: 1550nm	West optic TX: 1550nm RX: 1310nm East optic TX: 1310nm RX: 1550nm	TX: 1550nm RX: 1310nm
Output power	3dBm±1dBm to ROU,OEU	3dBm±1dBm to ROU 7dBm±1dBm to ODU	7dBm±1dBm to ODU

3.1.3 Environmental specifications

Parameter	BIU, ODU, OEU	ROU
Operating Temperature	-10 to +50°C	-10 to +50°C
Operating Humidity, non condensing	-	5% to 90%

3.1.4 Operating Frequencies range

Standard	Unit naming	Description	Frequency range	
			TX(MHz)	RX(MHz)
iDEN	700P	Public safety	764 to 776	794 to 806
iDEN	800P	Public safety	851 to 869	806 to 824
Cellular	850C	Cellular	869 to 894	824 to 849
Iden	900I	SMR	929 to 940	896 to 902
Paging	900 PA	Paging	929 to 930	896 to 902
PCS	1900P	PCS	1930 to 1995	1850 to 1915
AWS-1	AWS-1	AWS-1	2110 to 2155	1710 to 1755
-	VHF	Public safety	136 to 174	136 to 174
-	UHF	Public safety	396 to 512	396 to 512

3.1.5 Specifications Per band

700MHz Public safety

Parameters	Typical		Remarks
	TX	RX	
Bandwidth	12MHz	12MHz	
System ripple	≤4dB	≤4dB	
Input Power level	-20 to +10dBm	≤-50dBm	
Output power	+23dBm	+0dBm	Total
System Gain	43dB	50dB	
Gain Control range	18 to 43dB	30 to 50dB	
IM3	-13dBm	-	
IP3	-	+23dBm	
Noise figure	-	15dB	1ROU

800MHz Public safety

Parameters	Typical		Remarks
	TX	RX	
Bandwidth	18MHz	18MHz	
System ripple	≤4dB	≤4dB	
Input Power level	-20 to +10dBm	≤-50dBm	
Output power	+23dBm	+0dBm	Total
System Gain	43dB	50dB	
Gain Control range	18 to 43dB	30 to 50dB	
IM3	-13dBm	-	
IP3	-	+23dBm	
Noise figure	-	15dB	1ROU

850MHz Cellular

Parameters	Typical		Remarks
	TX	RX	
Bandwidth	25MHz	25MHz	
System ripple	≤4dB	≤4dB	
Input Power level	-20 to +10dBm	≤-50dBm	
Output power	+23dBm	+0dBm	Total
System Gain	43dB	50dB	
Gain Control range	18 to 43dB	30 to 50dB	
IM3	-13dBm	-	
IP3	-	+23dBm	
Noise figure	-	15dB	1ROU

900MHz iDEN & Paging

Parameters	Typical		Remarks
	TX	RX	
Bandwidth	12MHz	6MHz	
System ripple	≤4dB	≤4dB	
Input Power level	-20 to +10dBm	≤-50dBm	
Output power	+23dBm	+0dBm	Total
System Gain	43dB	50dB	
Gain Control range	18 to 43dB	30 to 50dB	
IM3	-13dBm	-	
IP3	-	+23dBm	
Noise figure	-	15dB	1ROU

1900MHz PCS

Parameters	Typical		Remarks
	TX	RX	
Bandwidth	65MHz	65MHz	
System ripple	≤5dB	≤5dB	
Input Power level	-20 to +10dBm	≤-50dBm	
Output power	+26dBm	+0dBm	Total
System Gain	46dB	50dB	
Gain Control range	21 to 46dB	30 to 50dB	
IM3	-13dBm	-	
IP3	-	+23dBm	
Noise figure	-	15dB	1ROU

1700MHz&2100MHz AWS-1

Parameters	Typical		Remarks
	TX	RX	
Bandwidth	45MHz	45MHz	
System ripple	≤5dB	≤5dB	
Input Power level	-20 to +10dBm	≤-50dBm	
Output power	+26dBm	+0dBm	Total
System Gain	46dB	50dB	
Gain Control range	21 to 46dB	30 to 50dB	
IM3	-13dBm	-	
IP3	-	+23dBm	
Noise figure	-	15dB	1ROU

150MHz VHF Public safety

Parameters	Typical		Remarks
	TX	RX	
Bandwidth	38MHz	38MHz	
ripple	≤3dB	≤3dB	
Input Power level	-18dBm	≤-54dBm	
Output power	+24dBm	-1dBm	Total
Gain	42dB	53dB	
Gain Control range	17to 42dB	8 to 53dB	
IM3	-13dBm	-	
IP3	-	+23dBm	
Noise figure	-	7dB	1ROU

450MHz UHF Public safety

Parameters	Typical		Remarks
	TX	RX	
Bandwidth	116MHz	116MHz	54MHz, 62MHz Band selection
ripple	≤3dB	≤3dB	
Input Power level	-14dBm	≤-54dBm	
Output power	+24dBm	-6dBm	Total
Gain	38dB	48dB	
Gain Control range	13 to 38dB	3 to 48dB	
IM3	-13dBm	-	
IP3	-	+23dBm	
Noise figure	-	7dB	1ROU

Section4

System Configuration and Functions

-
- 4.1 BIU (BTS Interface Unit)**
 - 4.2 ODU (Optic distribution Unit)**
 - 4.3 OEU (Optic Expansion Unit)**
 - 4.4 ROU (Remote Optic Unit)**

4.1 BIU (BTS Interface Unit)

BIU provides TX signals from BTS or BDA for four ODUs (Optic Distribution Unit). This unit separates RX signals given from ODUs from each other per frequency band.

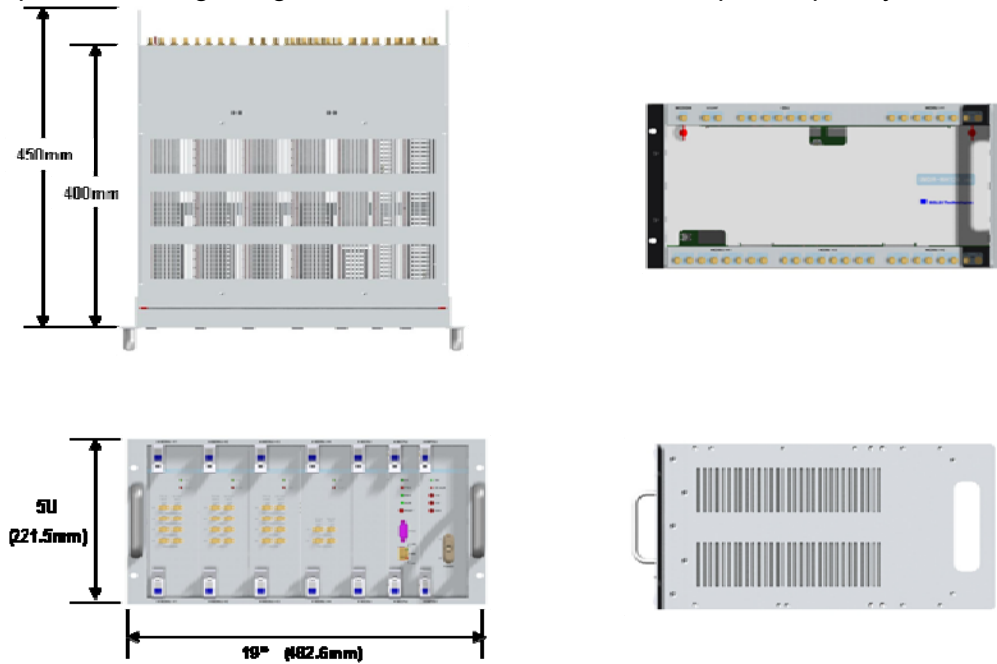
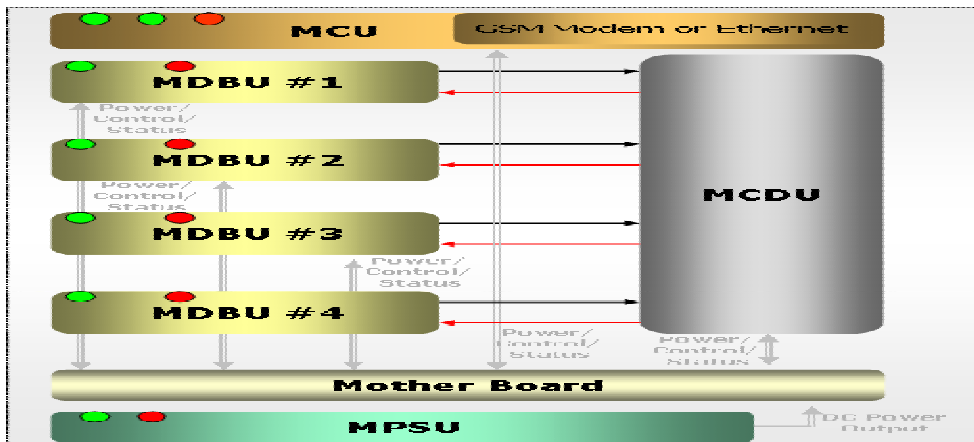

Figure 4.1 – BIU outer view

4.1.1 Specifications of BIU

Item	Spec.	Remark
Size	482.6(19") x 221.5(5U) x 450	Mm
Weight	22.35 Kg	Full Load
Power consumption	168 W	

4.1.2 Block diagram of BIU



4.1.3 BIU parts

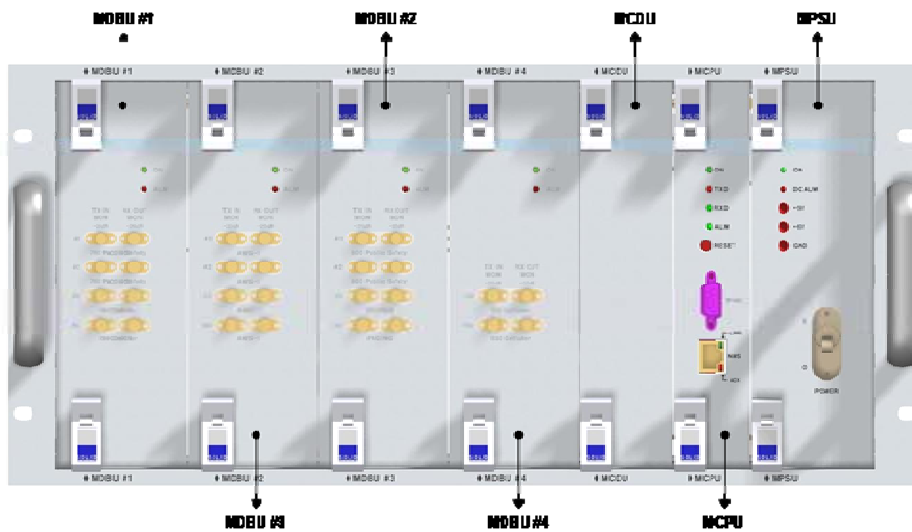

Figure 4.2 – BIU mounting diagram

No.	Unit	Description	Remark
1	MDBU	Main Drive BTS Unit Amplify & adjust downlink RF signal Amplify & adjust uplink RF signal	Max 4EA

2	MCDU	Main Com/Div Unit Combine 4EA downlink signal and divide 4EA signal to ODU Combine 4EA uplink signal and divide 4EA signal to MDBU Support VHF/UHF interface port
3	MCPU	Main Central Processor Unit Control and monitoring system status Control and monitoring with RS232 Have an access to upper-level network through GSM or Ethernet
4	MPSU	Main Power Supply Unit Input power: DC -48V, Output power: 9V, 6V
5	M/B	Mother Board Provide signal interface and power for each unit Provide three ports for dry contact
6	Shelf	19 inch, 5U

4.1.4 Function by unit

1) Main Drive BTS Unit (MDBU)

MDBU delivers TX signals of BTS or BDA to related devices and then delivers RX signals of the devices to BTS or BDA. This unit can monitor TX input level. Using input AGC function, it automatically adjusts input ATT. It also has ATT to adjust RX gain. MDBU is varied per frequency band including the following:

No	Unit naming	Description	In/out RF Port	
			TX	RX
1	800PS	Single Band	2 Port	2 Port
2	850C	Single Band	2 Port	2 Port
3	1900P	Single Band	4 Port	4 Port
4	AWS-1	Single Band	4 Port	4 Port
5	800PS+900I+PA	Dual Band	4 Port	4 Port
6	850C+700PS	Dual Band	4 Port	4 Port
7	TBD			



800PS

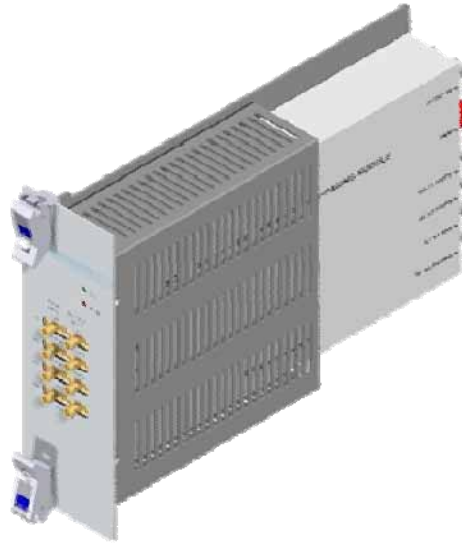

800PS+900I+Paging



1900PCS

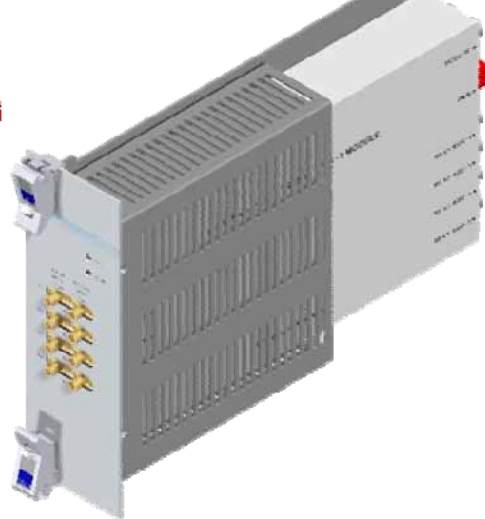

AWS-1

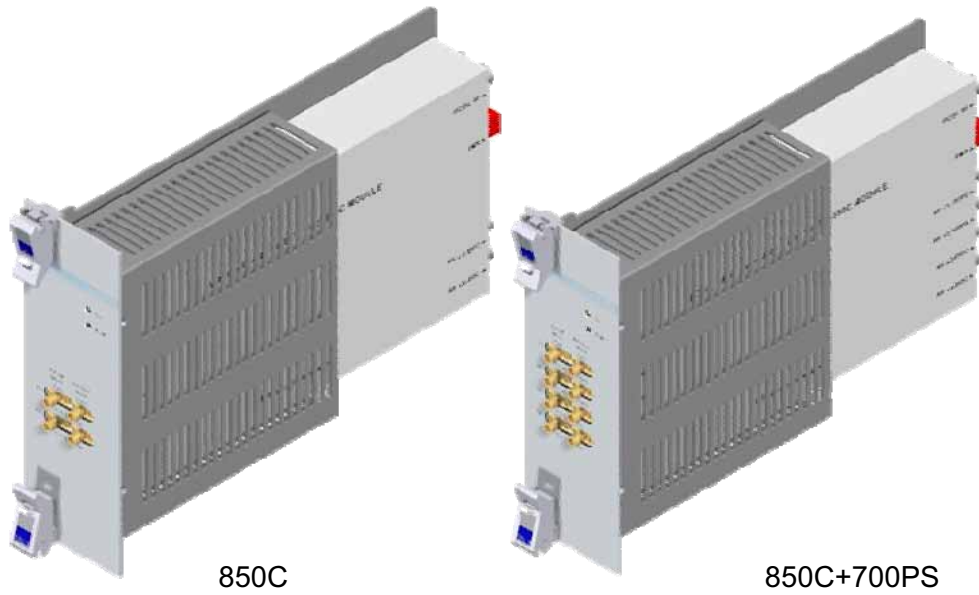

Figure 4.3 – MDBU Outer Look

2) Main Com/Div Unit (MCDU)

MCDU combines TX signals that are delivered from MDBU per frequency band and delivers the signals to four ODUs. This unit adds signals of FSK modem to the TX signals before sending them to ROU. It also combines RX signals from up to four ODUs and sends them to up to four MDBUs. In this case, the unit extracts signals of FSK modems, which are sent in a combined form with RX signals, and then delivers the signals to MCU.

The unit has a port to interface with VHF&UHF signals. It has ATT for input monitoring and input control.

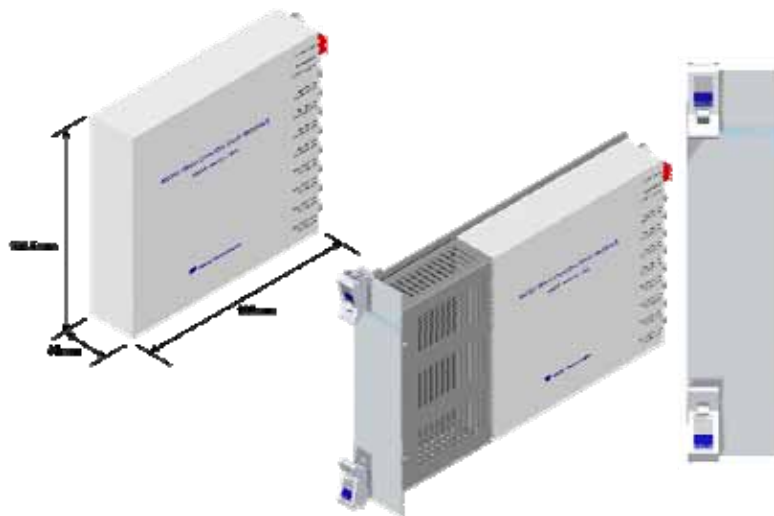

Figure 4.4 – MDBU Outer Look

VHF+UHF frequency band including the following:

No	Unit naming	Description	In/out RF Port	
			TX	RX
1	VHF+UHF	Dual Band	1 Port	1 Port

3) Main Central Processor Unit (MCPU)

MCPU can inquire and control state of modules that are installed in BIU.

This unit can inquire and control state of four ODUs in total. Through communication, it also can inquire and control ROU that is connected with lower parts.

In addition, the unit has RS-232C port for serial communication so that it can inquire and control state of devices through PC. On the front panel, it has communication LED indicator to check communication state with ROU. It also has ALM LED indicator to show whether a device gets faulty.

For access to upper network, it has a port to insert Ethernet port and GSM modem in it.

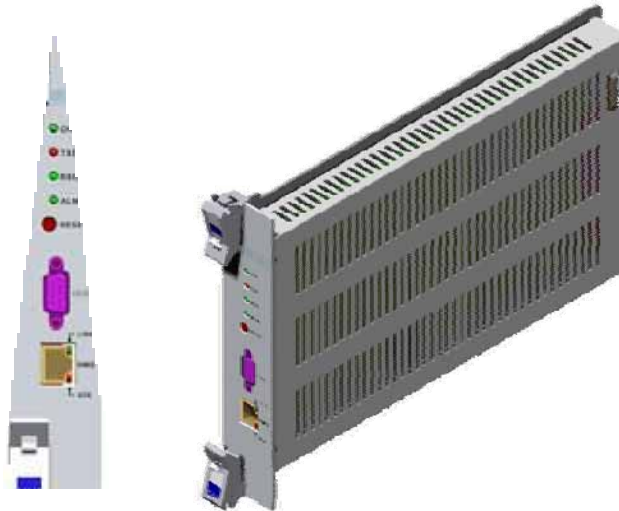

Figure 4.5 – MCCU Outer Look

In the Main Central Processor Unit, a lithium battery is installed for RTC (Real Time Control) function.



CAUTION

RISK OF EXPLOSION IF BATTERY IS REPLACED BY AN INCORRECT TYPE
 DIPOSE OF USED BATTERIES ACCORDING TO THE INSTRUCTIONS
 [INSTRUCTION]

The equipment and accessories including inner lithium battery are to be disposed of safely after the life span of them and national regulation must be observed. Do not attempt to replace the lithium battery unless service personnel confirmation has first been obtained, to avoid any risk of explosion.

4) Main Power Supply Unit (MPSU)

MPSU receives -48V of input and outputs +6V and +9V of DC power.

On the front panel, this unit has an output test port and it also has DC ALM LED Indicator to show whether output gets faulty.



Figure 4.6 – MPSU Outer Look

4.1.5 Front/rear panels of BIU

1) Front panel



Figure 4.7 – BIU front panel Outer Look

Item	Description
1. MDBU LED	LED to show whether MDBU is installed and gets faulty
2. RF Monitor Port	20dB Coupling compared with TX Input Level 20dB Coupling compared with RX Output Level
3. Alarm LED & Reset	Communication state with devices, alarm status of the system and reset switch
4. NMS(RS-232C port)	RS-232C port for communication and diagnosis of devices through PC/laptop
5. NMS(Ethernet port)	Ethernet port for upper network This equipment is indoor use and all the communication wirings are limited to inside of the building
6. Pwr Test Port & ALM	Output DC power test port and ALM LED to show abnormal state, if any
7. Power switch	Power ON/OFF switch

2) Rear panel

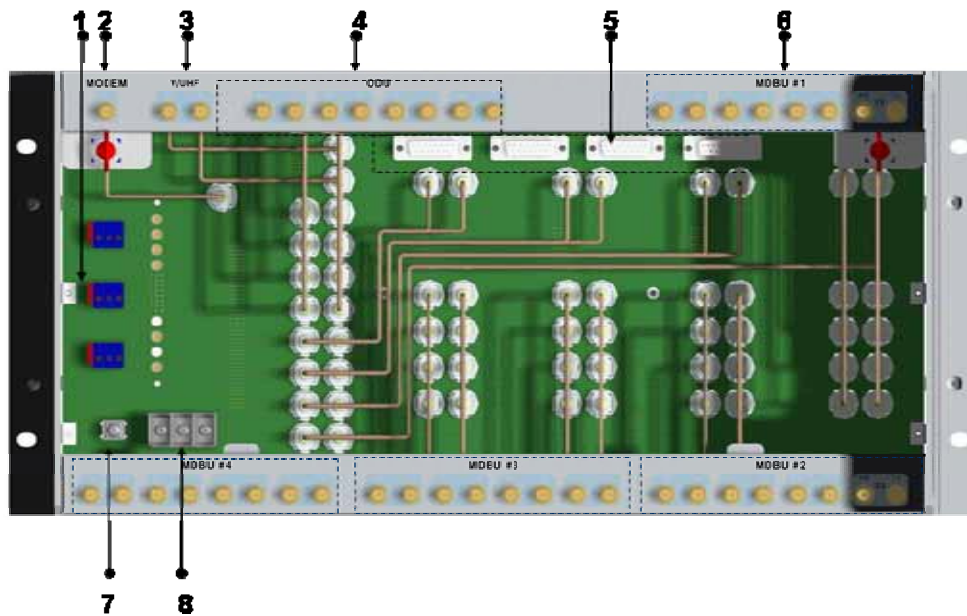

Figure 4.8 – Rear panel Outer Look

Item	Description
1. External ALM Port	Input/output terminal for dry contact
2. GSM Modem Port	GSM Modem terminal for upper network (Optional)
3. V/UHF I/O Port	RF signal interface terminal of VHF&UHF
4. ODU I/O Port	RF signal interface terminal for ODU
5. ODU signal Port	Power and signal interface terminal for ODU
6. BTS/BDA I/O Port	Input/output interface terminal of BTS/BDA
7. GND Port	System ground terminal
8. DC Input Port	Input terminal for DC -48V

4.2 ODU (Optic distribution Unit)

ODU receives TX RF signals from upper BIU and converts them into optical signals. The optical signals are sent to ROU through optical cables. This unit converts optical signals from ROU into RF signals and sends the converted signals to BIU.

For each shelf of the ODU, up to two DOUs (Donor Optic Unit) can be installed in it.

One DOU is supported with four optical ports. Therefore, one ODU can be connected with eight ROUs.

Up to four ODUs can be connected with BIU.

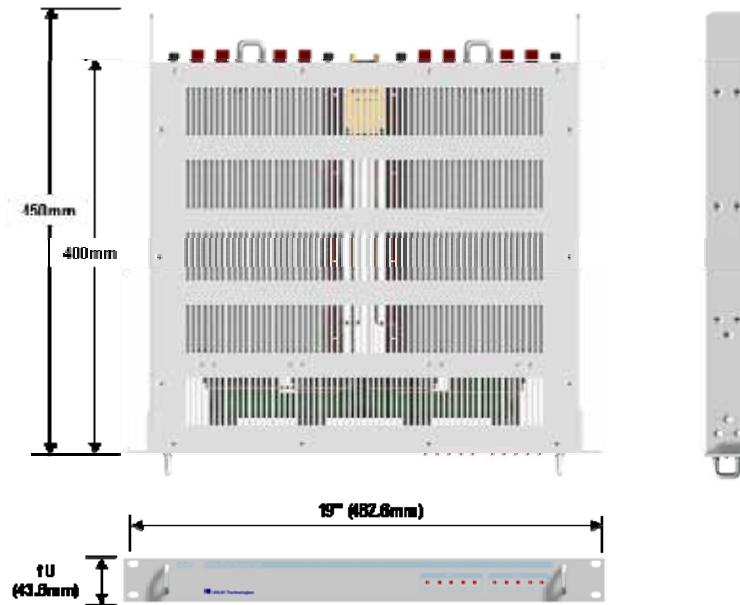

Figure 4.9 – ODU Outer Look

4.2.1 Specifications of ODU

Item	Spec.	Remark
Size	482.6(19") x 43.6(1U) x 450	Mm
Weight	5.7 Kg	Full Load
Power consumption	27 W	

4.2.2 Block Diagram of ODU

