

SC-DAS

Installation and Operation Manual



Document Reference:

Version:	V3.0
Document Status:	Release 3
Issue Date:	January. 06, 2012
Author:	Kyung Eun Han
Department:	R&D Division Team 3
Authorizing Manager:	Young shin Yeo

REVISION HISTORY

Version	Issue Date	No. of Pages	Initials	Details of Revision Changes
V 1.0	April. 11, 2011		Original	
V 2.0	Dec. 08,2011			Add Sprint band
V 3.0	Jan. 06,2012			

Technical Support

SOLiD serial numbers must be available to authorize technical support and/or to establish a return authorization for defective units. The serial numbers are located on the back of the unit, as well as on the box in which they were delivered. Additional support information may be obtained by accessing the SOLiD Tehcnology, Inc. website at www.st.co.kr or send email at sjkim@st.co.kr

This manual is produced by Global Business Division Business Team 1. Printed in Korea.

Contents

Section1	<i>Safety & Certification Notice</i>	<i>14</i>
Section2	<i>System Overview</i>	<i>17</i>
2.1	<i>General overview</i>	<i>18</i>
2.2	<i>System overview.....</i>	<i>20</i>
Section3	<i>System Specifications</i>	<i>23</i>
3.1	<i>System specifications.....</i>	<i>24</i>
3.1.1	<i>Physical Specifications</i>	<i>24</i>
3.1.2	<i>Optical wavelength and Laser power.....</i>	<i>27</i>
3.1.3	<i>Environmental specifications</i>	<i>27</i>
3.1.4	<i>Available Frequency Bands.....</i>	<i>27</i>
3.1.5	<i>Band Specifications.....</i>	<i>28</i>
Section4	<i>System Configuration and Functions.....</i>	<i>30</i>
4.1	<i>BIU (BTS Interface Unit)</i>	<i>31</i>
4.1.1	<i>BIU Specifications</i>	<i>31</i>
4.1.2	<i>BIU block diagram.....</i>	<i>32</i>
4.1.3	<i>BIU assemblies.....</i>	<i>33</i>
4.1.4	<i>Sub Assembly Description</i>	<i>34</i>
4.1.5	<i>BIU front/rear panel overview</i>	<i>39</i>
4.2	<i>ODU (Optic distribution Unit).....</i>	<i>43</i>
4.2.1	<i>ODU specifications.....</i>	<i>43</i>
4.2.2	<i>ODU block diagram</i>	<i>44</i>
4.2.3	<i>ODU assemblies</i>	<i>44</i>
4.2.4	<i>Sub Assembly description</i>	<i>46</i>
4.2.5	<i>ODU front/rear panel overview</i>	<i>47</i>
4.2.6	<i>ODU Interface with BIU.....</i>	<i>48</i>
4.3	<i>OEU (Optic Expansion Unit).....</i>	<i>51</i>
4.3.1	<i>Specifications of OEU.....</i>	<i>51</i>
4.3.2	<i>OEU block diagram</i>	<i>52</i>
4.3.3	<i>OEU assemblies.....</i>	<i>53</i>
4.3.4	<i>Sub Assembly description</i>	<i>54</i>
4.3.5	<i>OEU front/rear panel overview.....</i>	<i>57</i>
4.4	<i>ROU (Remote Optic Unit).....</i>	<i>58</i>

4.4.1	ROU specifications.....	60
4.4.2	ROU block diagram	61
4.4.2.1	Combination of MRU 1900PCS+850C/ARU 700LTE+AWS-1	61
4.4.2.2	Combination of MRU 1900PCS/ARU 900l+800l	62
4.4.3	ROU assemblies	63
4.4.3.1	Combination of MRU 1900PCS+850C/ARU 700LTE+AWS-1	63
4.4.3.2	Combination of MRU 1900PCS/ARU 900l+800l	65
4.4.4	Sub Assembly description	68
4.4.5	Bottom of ROU	70
4.4.6	Top of ROU	72
4.4.6.1	Combination of MRU1900PCS+850C/ARU700LTE+AWS-1	72
4.4.6.2	Combination of MRU1900PCS+850C/ARU700LTE+AWS-1	72
Section 5	System Installation & Operation	75
5.1	BIU Installation	77
5.1.1	BIU Shelf Installation.....	77
5.1.2	BIU Power Cabling	78
5.1.3	BIU/RF interface	82
5.1.4	MDBU installation	87
5.1.5	ODU Interface	89
5.1.6	BIU power consumption.....	93
5.2	ODU Installation.....	94
5.2.1	ODU Shelf Installation	94
5.2.2	ODU Power Cabling.....	94
5.2.3	ODU Optic Cabling	94
5.2.4	DOU installation.....	95
5.2.5	ODU Power consumption.....	97
5.3	ROU Installation.....	98
5.3.1	ROU Enclosure installation	98
5.3.2	ROU Power Cabling	106
5.3.3	Optical Cabling.....	108
5.3.4	GND Terminal Connection	109
5.3.5	Coaxial cable and Antenna Connection	109
5.3.6	LED explanation on ROU	110
5.3.7	ROU Power consumption	110
5.3.8	Cable connection between MRU and ARU.....	111
5.4	OEU Installation	113

5.4.1 OEU chassis installation.....	113
5.4.2 OEU Power Cabling	113
5.4.3 OEU Optic Cabling.....	115
5.4.4 DOU installation with an OEU	116
5.4.5 OEU Power Consumption	117
Section 6 Operation.....	119
6.1 BIU Overview	120
6.1.1 BIU	120
6.1.2 BIU TX parameters	120
6.1.3 BIU RX parameters.....	128
6.1.4 BIU Logic Sequence Diagram	129
6.1.5 Interaction with the BIU	133
6.2 ROU Overview	135
6.2.1 ROU Operation.....	135
6.3 OEU Operation.....	144
6.3.1 OEU Operation.....	144
Section 7 Additive functions.....	150
7.1 Shutdown function (TX output shutdown)	151
7.2 Total Power Limit function (TX Output ALC)	152
7.3 Automatic Output power setting function (TX Output AGC).....	152
7.4 Input power AGC function (TX Input AGC)	152
7.5 Input power limit function (TX Input ALC)	153
7.6 Optical loss compensation.....	154

Figures

Figure 2.1 – Basic system topology supporting SISO configuration	20
Figure 2.2 – Basic system topology supporting MIMO configuration	21
Figure 2.3 – Expansion system topology supporting SISO configuration.....	22
Figure 2.4 – Expansion system topology supporting MIMO configuration.....	23
Figure 4.1 – BIU front and side views.....	31
Figure 4.2 – BIU block diagram	32
Figure 4.3 – BIU mounting diagram.....	33
Figure 4.4 – MDBU at a glance.....	35
Figure 4.5 – MCDU at a glance	36
Figure 4.6 – MCPU at a glance	37
Figure 4.7 – MPSU at a glance	39
Figure 4.8 – BIU front panel view.....	39
Figure 4.9 – Rear panel view.....	41
Figure 4.10 – ODU at a glance	43
Figure 4.11 – ODU block diagram.....	44
Figure 4.12 – ODU Internal View	45
Figure 4.13 – DOU at a glance	46
Figure 4.14 – 2Way Divider at a glance.....	47
Figure 4.15 – ODU front panel view	47
Figure 4.16 – ODU Rear panel view	48
Figure 4.17 BIU/ODU interface	49

Figure 4.18 – BIU/ODU Interface rear view	50
Figure 4.19 – BIU/ODU interface details.....	50
Figure 4.20 – OEU at a glance	51
Figure 4.21 – OEU block diagram.....	52
Figure 4.22 – OEU internal view	53
Figure 4.23 – DOU at a glance.....	54
Figure 4.24 – EWDM at a glance.....	55
Figure 4.25 – ECPU at a glance.....	55
Figure 4.26 – ERFM at a glance	56
Figure 4.27 – EPSU at a glance	56
Figure 4.28 – OEU front panel view.....	57
Figure 4.29 – Rear panel view	57
Figure 4.30 – ROU at a glance.....	59
Figure 4.31 – ROU block diagram for MRU 1900PCS+850C and ARU 700LTE+AWS-1	61
Figure 4.32 – ROU block diagram for MRU 1900PCS and ARU 900l+800l.....	62
Figure 4.33 – ROU internal view for MRU1900PCS+850C and ARU 700LTE+AWS-1	64
Figure 4.34 – ROU internal view for MRU 1900PCS and ARU 900l+800l.....	66
Figure 4.35 – PSU at a glance.....	69
Figure 4.36 – ROU Bottom view	70
Figure 4.37 – ROU Power Port View.....	71
Figure 4.38 – ROU Top View for MRU 1900P+850C and ARU 700LTE+AWS-1.....	72
Figure 4.39 – ROU Top View for MRU 1900P+850C and ARU 700LTE+AWS-1.....	73

Figure 5.1 – RACK Installation	77
Figure 5.2 – Power interface diagram	79
Figure 5.3 – PSU LED indicator information	81
Figure 5.4 – BIU RF interface diagram	84
Figure 5.5 – BTS /BIU connections.....	85
Figure 5.6 –BDA Interface using Circulator	85
Figure 5.7 –BDA Interface using Duplexer	86
Figure 5.8 –MDBU LED indicator information	89
Figure 5.9 –Interface port between BIU and ODU	90
Figure 5.10 –Cabling interface diagram between BIU and ODU	91
Figure 5.11 –SC/APC fiber termination	95
Figure 5.12 – ODU rear view with DOUs inserted	95
Figure 5.13 – Wall mount dimensions for the ROU	98
Figure 5.14 – ROU installation procedure side by side	99
Figure 5.15 – ROU installation diagram side by side.....	100
Figure 5.16 – ROU installation procedure for stacked mounting	101
Figure 5.17 – ROU installation diagram for stacked mounting.....	101
Figure 5.18 – ROU installation procedure for vertical rack	102
Figure 5.19 – ROU installation diagram for vertical rack	103
Figure 5.20 – ROU installation procedure for horizontal rack	104
Figure 5.21 – ROU installation diagram for horizontal rack	104
Figure 5.22 – ROU Power Port view	106
Figure 5.23 – ROU optical Port view	108
Figure 5.24 – ROU GND Port view	109

Figure 5.25 – ROU LED indicator information.....	110
Figure 5.26 – OEU Power interface diagram	114
Figure 5.27 – Optical cable with SC/ACP Type Connectors.....	116
Figure 5.28 – OEU with DOUs inserted	116
Figure 6.1 – SC-DAS Link budget for the BIU	120
Figure 6.2 –MDBU information assigned at theBIU.....	123
Figure 6.3 –MDBU menu information at the BIU	124
Figure 6.4 –MDBU name assignment at theBIU.....	127
Figure 6.5 –MDBU name assignment at the tree	127
Figure 6.6 –MDBU Module Failure information at the BIU	128
Figure 6.7 –Configuration of BIU-ODU-ROU for basic topology.....	130
Figure 6.8 –Configuration of BIU-ODU-ROU for expansion topology.....	131
Figure 6.9 –DOU assignment at the BIU	133
Figure 6.10 –ODU Menu information.....	134
Figure 6.11 –SC-DAS Link budget for ROU	135
Figure 6.12 –Optical information at the ROU	138
Figure 6.13 –ROU information assignment	140
Figure 6.14 –ROU Menu information.....	141
Figure 6.15 –ROU Softkey information	143
Figure 6.16 –SC-DAS Link Budget for OEU	144
Figure 6.17 –OEU Optical information	147
Figure 7.1 –Shutdown logic diagram.....	151
Figure 7.2 –Optical loss information.....	154

Section1

Safety & Certification Notice

“Only qualified personnel are allowed to handle this unit. Read and obey all the warning labels attached in this user manual”

Any personnel involved in installation, operation or service of the SOLiD Technology repeaters must understand and obey the following:

- Obey all general and regional installation and safety regulations relating to work on high voltage installations, as well as regulations covering correct use of tools and personal protective equipment.
- The power supply unit in repeaters contains dangerous voltage levels which can cause electric shock. Switch the mains off prior to any work in such a repeater. Any local regulations are to be followed when servicing repeaters.
- The repeater cover (door) should be securely fastened in open position(with a cord), during outdoor work in order to prevent door from slamming due to wind (which could cause bodily harm or damage).
- Use this unit only for the purpose specified by the manufacturer. Do not carry out any modifications or replace any parts which are not sold or recommended by the manufacturer. This could cause fire, electric shock or other injuries.
- Repeaters generate radio signals and thereby give rise to electromagnetic fields that may be hazardous to any person in the immediate proximity of the repeater and the repeater antennas for an extended period of time.
- Due to power dissipation, this repeater may reach a very high temperature. Do not operate this unit on or close to flammable materials.
- Do not use any solvents, chemicals, or cleaning solutions containing alcohol, ammonia, or abrasives.
- Certification
 - FCC: This equipment complies with the applicable sections of Title 47 CFR Parts 15,22,24 and 90
 - UL/CUL: This equipment complies with UL and CUL 1950-1 Standard for safety for information technology equipment,including electrical business equipment
 - FDA/CDRH: This equipment uses a Class 1 LASER according to FDA/CDRH Rules.This product conforms to all applicable standards of 21 CFR Chapter 1, Subchapter J, Part 1040
- For PLUGGABLE EQUIPMENT, the socket-outlet shall be installed near the equipment and shall be easily accessible.

Section2

System Overview

-
- 2.1 General overview**
 - 2.2 System overview**

2.1 General overview

SC-DAS platform is a coverage system for in-building services delivering seamless, high quality voice and data. As a distributed antenna system, it provides analog and digital phone services in multiple bands through one antenna.

The system covers public and private venues such as:

- Shopping malls
- Hotels
- Campus areas
- Airports
- Clinics
- Subways
- Multi-use stadiums, convention centers, etc.

The system enhances in-building radio environments that lack signal quality by improving the RSSI and E_c/I_0 . By providing communication services throughout the building, the system enables users to make a calls anywhere in the coverage area.

The system uses both analog (AMPS) and digital (TDMA, CDMA and WCDMA) methods.

The SC-DAS system supports communication standards and public interface protocols in worldwide use.

- Frequencies: VHF,UHF, 700MHz, 800MHz,850MHz 900MHz,1900MHz,2100MHz, etc.
- Voice protocols: AMPS,TDMA, CDMA,GSM,IDEN, etc.
- Data protocols: EDGE,GPRS,WCDMA,CDMA2000,Paging,LTE, etc.

SC-DAS comprises frequency specific modules. Coverage for a specific frequency band is accomplished by inserting a corresponding frequency module into each unit. Because it delivers multiple signals with one strand of single mode fiber, the system, requires no additional hardware modifications whenever a new frequency is added.

The system is featured with the following:

- Flexibility & Scalability
 - Supports fiber-optic ports up to 32 or 60(using OEU)
 - Connects multiple-buildings (campus) as one DAS
- Modular structures
 - Modular frequency upgrade
 - Plug-in type modules
- Multi-Band, Single operator
 - Supports multiple services from one WSP

- Support multi-operator in a band(Max. 2 operator)
- Low OPEX / CAPEX
 - Compact design
 - Upgradable design
 - Easy installation and maintenance
 - Adopts auto ID scheme

The SC-DAS platform will serve two primary segments; first as a carrier deployed coverage enhancement product for their specific frequencies and second as a low cost, public safety / single carrier product.

2.2 System overview

SC-DAS comprises the components listed below.

The base system consists of a BIU (BTS Interface Unit), an ODU (Optic distribution Unit) and a ROU (Remote Optic Unit). For use with multiple ROU's, it has OEU (Optic Expansion Unit).

The BIU has two layer which support both SISO and MIMO configuration using separate optical fiber cable. Fig2.1 shows basic system topology for SISO

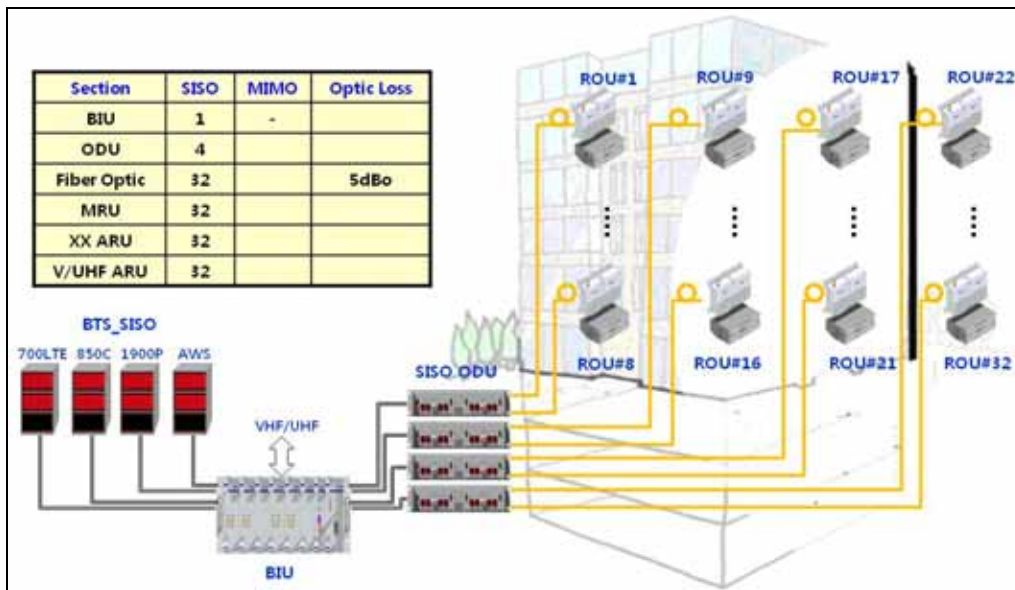

Figure 2.1 – Basic system topology supporting SISO configuration

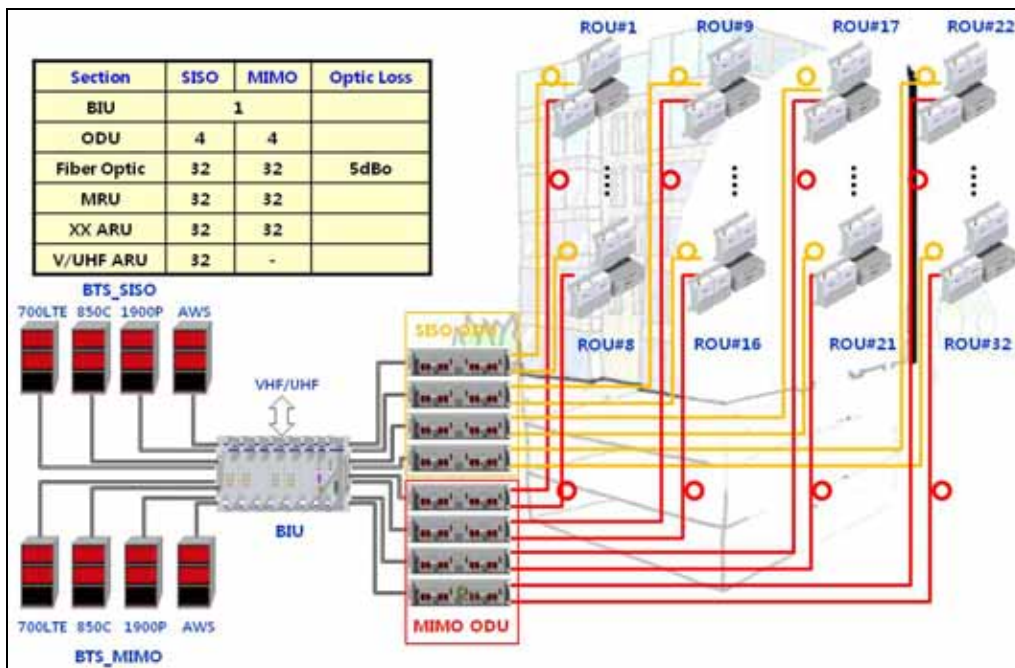

Figure 2.2 – Basic system topology supporting MIMO configuration

As shown at Fig.'s 2.1 and 2.2, one strand of fiber is needed for SISO configuration but two strands are needed for MIMO configuration when connected with an ROU. Applications requiring up to 32 ROU's for SISO are possible with one BIU. Each SISO ROU will require an additional strand of fiber and an additional 32 ROU's can be added to the same system for MIMO applications. MIMO requires 2 strands of fiber per ROU as well as MIMO specific ODU's.

To reduce number of optical cables between multi-building applications, we can utilize the OEU(Optical Expansion Unit)

Fig 2.3 shows expansion system topology supporting SISO configuration using OEUs

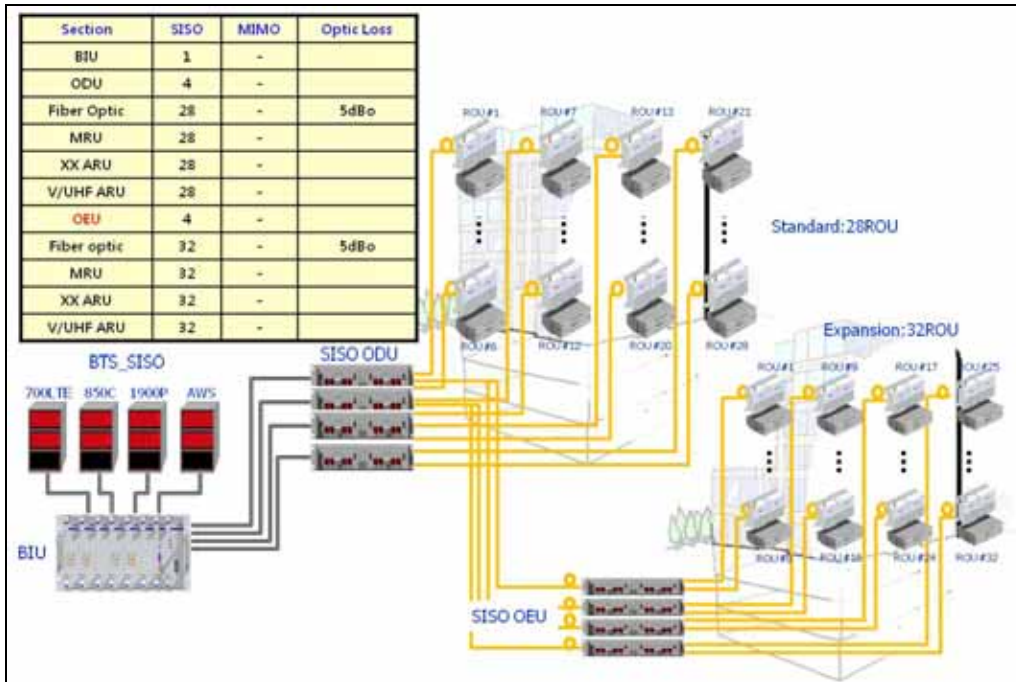

Figure 2.3 – Expansion system topology supporting SISO configuration

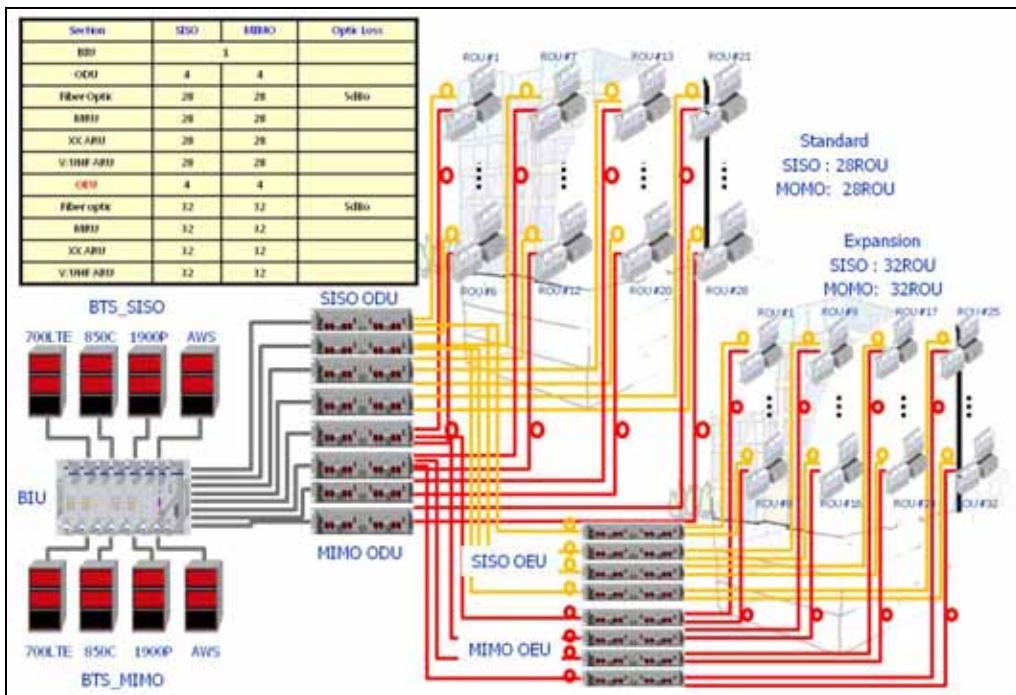

Figure 2.4 – Expansion system topology supporting MIMO configuration

Fig 2.4 shows expansion system topology supporting MIMO configuration using OEU

Section 3

System Specifications

- 3.1 System specifications**
 - 3.1.1 Physical Specifications**
 - 3.1.2 Optic wavelength and Laser power**
 - 3.1.3 Environmental specifications**
 - 3.1.4 Available frequency bands**
 - 3.1.5 Band Specifications**

3.1 System specifications

3.1.1 Physical Specifications

Parameter	BIU	ODU	OEU	MRU	ARU
RF Connectors	4 SMA pairs(TX,RX) per MDBU	2 SMA	-	1 N-type 2SMA :optical 2SMA :RF	2SMA :optical 2SMA :RF
External Alarm connector (Dry contacts)	TB: 4pcs for output TB: 3pcs for input	-	-	-	-
Serial Interface connector	1 USB(B) type		1 USB(B) type	1 USB(B) type	1 USB(B) type
Fiber connector	-	8pcs, SC/APC for ROU	1 SC/APC for ODU 8 SC/APC for ROU	1 SC/APC for ODU	-
LED Alarm and Status Indicator	<p>MDBU Status</p> <ul style="list-style-type: none"> ● Power status ● ALM status <p>MCPU</p> <ul style="list-style-type: none"> ● Power status ● TX Comm ● RX Comm ● ALM status <p>MPSU</p> <ul style="list-style-type: none"> ● Power status ● DC ALM status 	<p>DOU1 Status</p> <ul style="list-style-type: none"> ● LD status ● PD1/2/3/4 status <p>DOU2 Status</p> <ul style="list-style-type: none"> ● LD status ● PD1/2/3/4 status 	<p>EWDM Status</p> <ul style="list-style-type: none"> ● LD status ● PD status <p>DOU1 Status</p> <ul style="list-style-type: none"> ● LD status ● PD1/2/3/4 status <p>DOU2 Status</p> <ul style="list-style-type: none"> ● LD status ● PD1/2/3/4 status <p>System status</p> <ul style="list-style-type: none"> ● Power status ● TX1 Comm ● RX1 Comm ● TX2 Comm ● RX2 Comm ● ALM status 	<p>System status</p> <ul style="list-style-type: none"> ● Power status ● TX Comm ● RX Comm ● ALM status ● Opt status 	<p>System status</p> <ul style="list-style-type: none"> ● Power status ● TX Comm ● RX Comm ● ALM status
AC Power	-	-		Normal Range: 120VAC 50/60Hz Operating range 108~132VAC,50/60Hz	Same to left side
DC Power	Normal range: -48 VDC Operating range: -40.8 ~ -57.6VDC	Be provided by BIU		Normal: -48 VDC Operating range: -40.8 ~ -57.6VDC	Same to left side
Power consumption	SISO Mode : 162W (Including SISO ODU 4EA) MIMO Mode : 315W (Including SISO ODU 4EA+MIMO ODU 4EA)	28W (Including DOU2EA)	40W (Including DOU2EA)	MRU1900P+850C:50W MRU 1900P:45W	ARU700LTE+AWS:40W ARU900I+800I:44W
Enclosure Dimensions	482.6(19") x 221.5(5U) x 450	482.6(19") x 43.6(1U) x 450	482.6(19") x 88.1(2U) x 450	300 x 200 x 258	300 x 200 x 258
Weight[Full Load]	26.2Kg	6Kg	9.6Kg	6.6Kg	6.8Kg

3.1.2 Optical wavelength and Laser power

Parameter	ODU	OEU	ROU
Optical Wavelength	TX: 1310nm RX: 1550nm	West optic TX: 1550nm, RX: 1310nm East optic TX: 1310nm, RX: 1550nm	TX: 1550nm RX: 1310nm
Output power	1.5dBm±1dBm to ROU,OEU	1dBm±1dBm to ROU 7dBm±1dBm to ODU	7dBm±1dBm to ODU
Return loss	<45dB	<45dB	<45dB

3.1.3 Environmental specifications

Parameter	BIU, ODU, OEU	ROU/AOR
Operating Temperature	-10 to +50°C	-10 to +50°C
Operating Humidity, non condensing	-	5% to 90%

3.1.4 Available Frequency Bands

Standard	Unit naming	Description	Frequency range		Status
			TX(MHz)	RX(MHz)	
iDEN	700PS	Public safety	763 to 775	793 to 805	In future
iDEN	800PS	Public safety	851 to 869	806 to 824	Completed
Cellular	850C	Cellular	869 to 894	824 to 849	Completed
iDEN	900I	SMR	935 to 940	896 to 901	Completed
Paging	900 PA	Paging	929 to 930	896 to 902	In future
PCS	1900P	PCS	1930 to 1995	1850 to 1915	Completed
AWS-1	AWS-1	AWS-1	2110 to 2155	1710 to 1755	Completed
VHF	VHF	Public safety	136 to 174	136 to 174	In future
UHF	UHF	Public safety(Band1)	396 to 450 450 to 512	396 to 450 450 to 512	In future
E-UHF		Public safety(Band2)	380 to 434 434 to 496	380 to 434 434 to 496	In future
LTE	700LTE	Long Term Evolution	728 to 756	698 to 716 777 to 787	Completed

3.1.5 Band Specifications

SC-DAS platform allows many band combinations as well as different output power levels within the band depending on the combination.

1) Output power level

Below table shows Output power level as a function of band combination

Band Combinations		700PS	700LTE	800PS/I	850C	900I	1900P	AWS	VHF	UHF
MRU	ARU									
1900P+850C	700LTE+AWS	-	24dBm	-	24dBm	-	28dBm	28dBm	24dBm	24dBm
1900P+AWS	-	-	-	-	-	-	30dBm	30dBm		
1900P	900I+800I	-	-	26dBm	-	26dBm	31dBm	-		
1900P	-	-	-	-	-	-	30dBm	-		
1900P+850C	700PS+800PS	21dBm	-	-	-	-	30dBm	-		
700PS+800PS	900I+800I	21dBm	-	21dBm	-	21dBm	-	-		

On the loadmap

2) General Specifications

Parameter	Specifications	Remark
Gain Control range	TX	25dB/step 1dB
	RX	20dB/step 1dB
TX input power	-20dBm~+10dBm	
Spurious Emission	< -13dBm	
Optical Link AGC	>10dB	
VSWR	1.8:1	
Pass-band Ripple	4dBp-p	
Max optical Loss	5dB	
Optical wavelength	1310nm/1550nm with WDM	
RX output power	0dBm	
RX input power	-50dBm Max	
Noise Figure	< 8dB	Excluding 700PS, 800PS

Section4

System Configuration and Functions

- 4.1 BIU (BTS Interface Unit)**
- 4.2 ODU (Optic distribution Unit)**
- 4.3 OEU (Optic Expansion Unit)**
- 4.4 ROU (Remote Optic Unit)**

4.1 BIU (BTS Interface Unit)

The BIU receives signals from the BTS or BDA through coaxial cable and transmits to four ODUs (Optic Distribution Unit).and The BIU separates RX signals received from ODUs according to their frequency band.

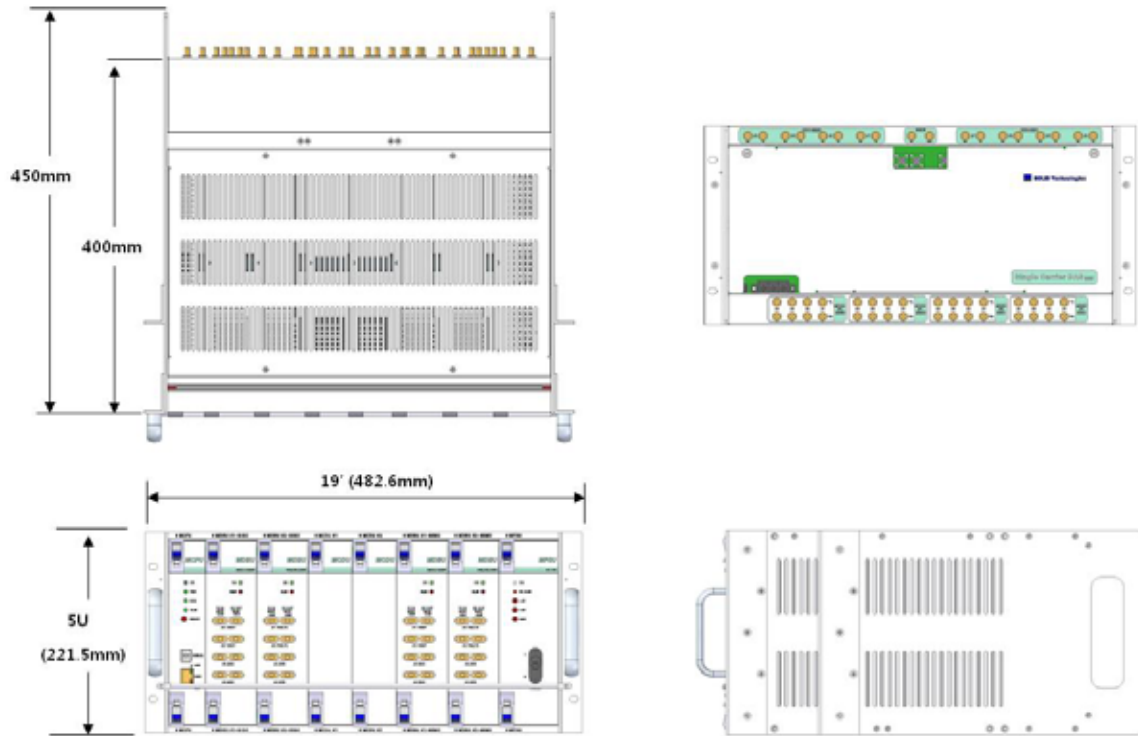

Figure 4.1 – BIU front and side views

4.1.1 BIU Specifications

Item	Spec.	Remark
Size	482.6(19") x 221.5(5U) x 450	mm
Weight	26 Kg	
Power consumption	SISO Mode : 168 W(Including SISO ODU 4EA) MIMO Mode : 315W(Including SISO ODU 4EA+MIMO ODU 4EA)	Full Load

4.1.2 BIU block diagram

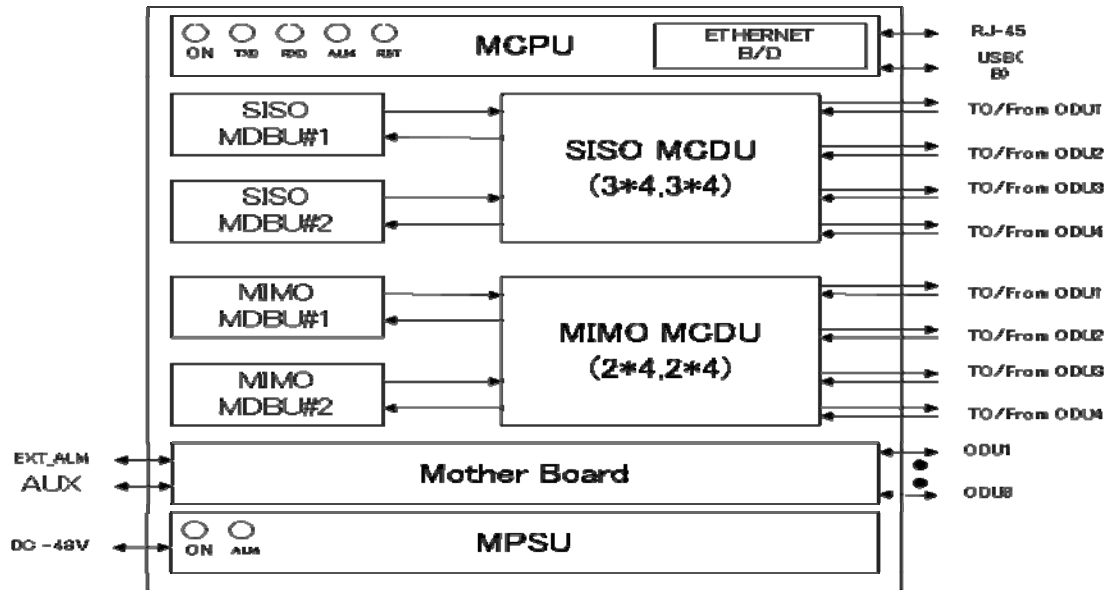

Figure 4.2 – BIU block diagram

4.1.3 BIU assemblies

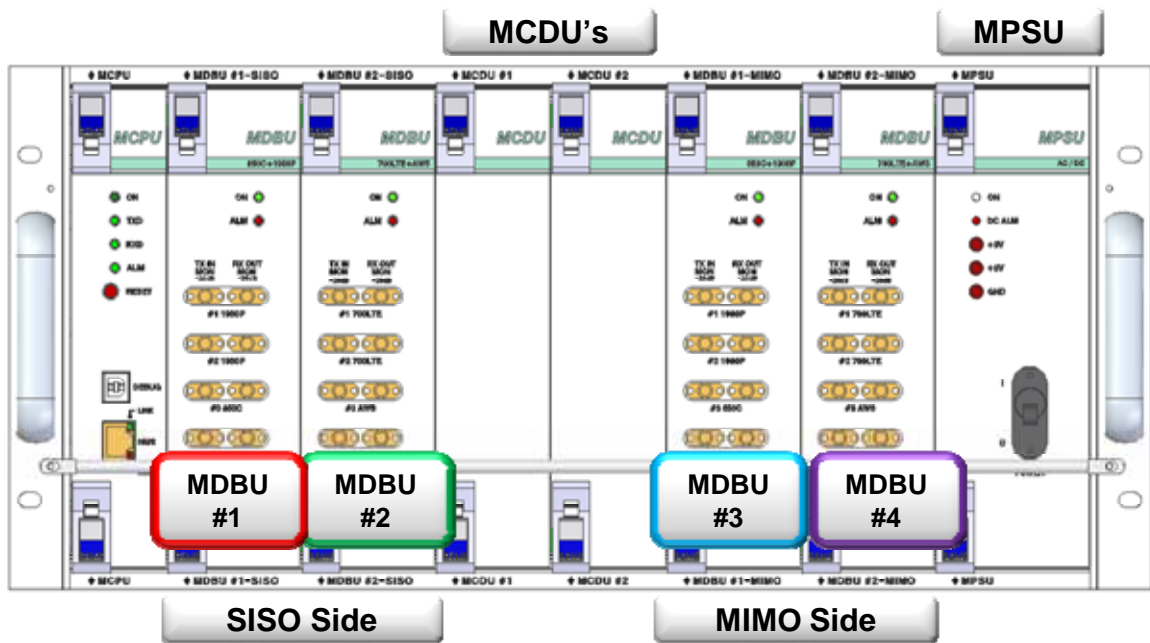

Figure 4.3 – BIU mounting diagram

No.	Unit	Description	Remark
1	MDBU	Main Drive BTS Unit Amplify & adjust downlink RF signal Amplify & adjust uplink RF signal	Max 4EA
2	MCDU	Main Com/Div Unit Combine 3EA downlink signal and divide 4EA signal to ODU Combine 4EA uplink signal and divide 3EA signal to MDBU Support VHF/UHF interface port	
3	MCPU	Main Central Processor Unit Control and monitoring system status Control and monitoring with USB(B) Allows access to upper-level network through GSM or Ethernet	
4	MPSU	Main Power Supply Unit Input power: DC -48V, Output power: 9V, 6V	
5	M/B	Mother Board Provide signal interface and power for each unit Provide four ports for dry contact output Provide three ports for input Provide two Aux ports for future usage	
6	Shelf	19 inch, 5U	

4.1.4 Sub Assembly Description

1) Main Drive BTS Unit (MDBU)

MDBU delivers TX signals from the BTS or BDA to related devices as well as delivers RX signals from these devices to the BTS or BDA. This unit also monitors TX input level. Using the input AGC function, it automatically adjusts input ATT according to input power. It also has an ATT to adjust RX gain. The MDBU varies per frequency band to including the following:

No	Unit naming	Description	In/out RF Port	
			TX	RX
1	1900P+850C	Dual Band	4 Port	4 Port
2	700LTE+AWS-1	Dual Band	4 Port	4 Port
3	1900P	Single Band	2 Port	2 Port
4	900I+800I	Dual Band	4 Port	4 Port
5	1900P+AWS-1			4 Port
6	700PS+800PS	On the loadmap		4 Port
7	900I	Dual Band	2 Port	2 Port

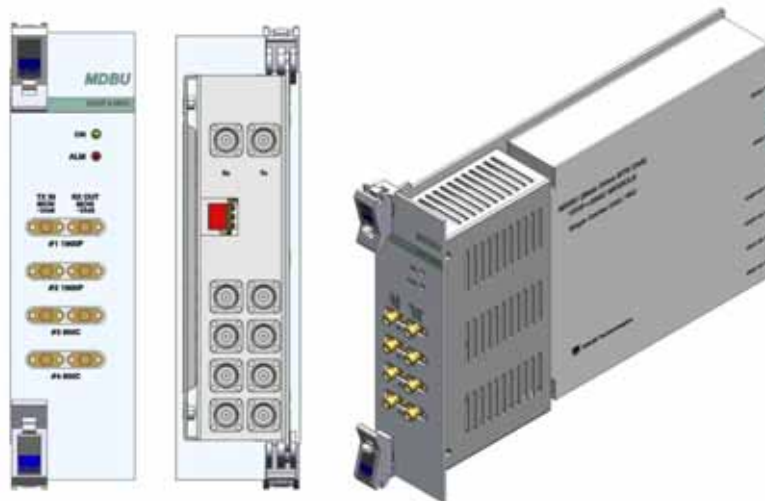

Figure 4.4 – MDBU at a glance

2) Main Com/Div Unit (MCDU)

MCDU combines TX signals that are delivered from MDBU per frequency band and delivers them to four ODUs. It also combines RX signals from up to four ODUs and sends them to up to four MDBUs. The unit has a port to interface with VHF&UHF signals. It has an ATT for input monitoring and input control.

The unit has a reserved port for future usage such as LMU interface, additive MDBU interface ,etc,

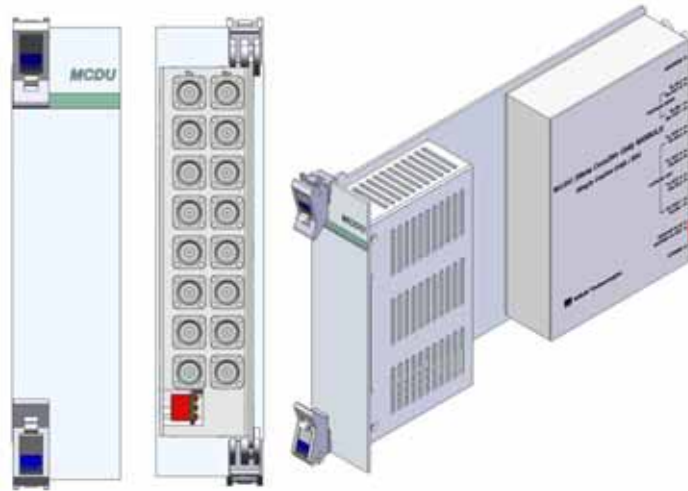

Figure 4.5 – MCDU at a glance

VHF+UHF frequency band includes the following: for use in future

No	Unit naming	Description	In/out RF Port	
			TX	RX
1	VHF+UHF	Dual Band	1 Port	1 Port

3) Main Central Processor Unit (MCPU)

MCPU can inquire and control the state of the modules that are installed in the BIU.

This unit can inquire and control the state of up to four ODUs. Through communication, it also can inquire and control ROUs that are connected.

In addition, the unit has USB(B) port for local monitoring so that it can inquire and control state of devices through a PC. On the front panel, it has communication LED indicators to check communication state with ROU. It also has ALM LED indicators to show whether a device is faulty.

For access to upper network, it has a port to insert an Ethernet port and GSM modem in it.

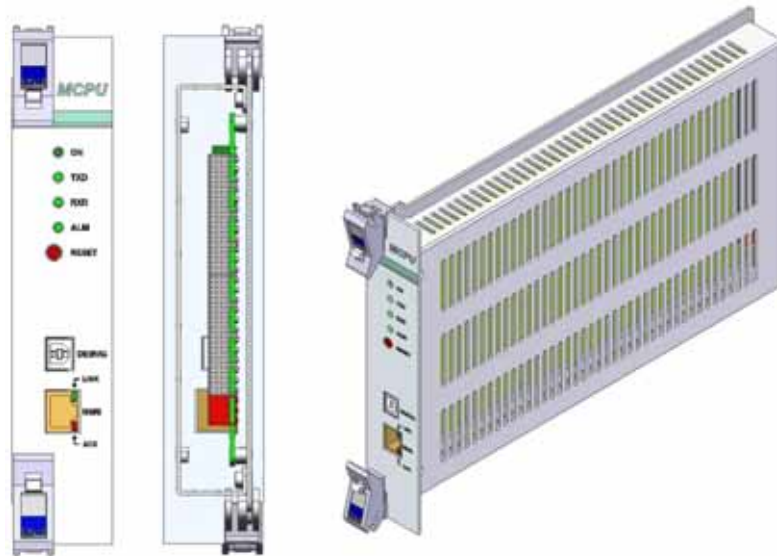

Figure 4.6 – MCU at a glance

In the Main Central Processor Unit, a lithium battery is installed for RTC (Real Time Control) function.



CAUTION

RISK OF EXPLOSION MAY OCCUR IF BATTERY IS REPLACED BY AN INCORRECT TYPE

DIPOSE OF USED BATTERIES ACCORDING TO THE INSTRUCTIONS

[INSTRUCTION]

The equipment and accessories including inner lithium battery are to be disposed of safely after the life span of them according to the national regulation. Do not attempt to replace the lithium battery unless authorized by a qualified service personnel, to avoid any risk of explosion.

4) Main Power Supply Unit (MPSU)

The MPSU takes a -48V input and outputs +6V and +9V DC power.

On the front panel, this unit has an output test port and it also has DC ALM LED Indicator to show faulty output.

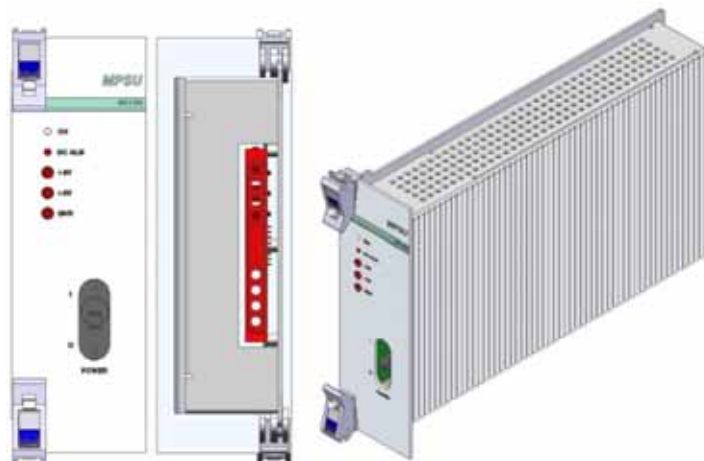

Figure 4.7 – MPSU at a glance

4.1.5 BIU front/rear panel overview

1) Front panel

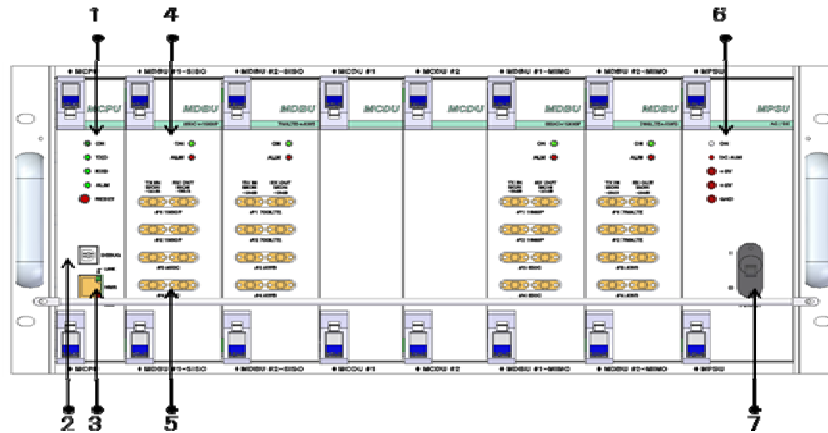

Figure 4.8 – BIU front panel view

Item	Description
1. Alarm LED & Reset	Communication state with devices, alarm status of the system and reset switch
2. DEBUG (USB B)	USB port for communication and diagnosis of devices through PC/laptop This equipment is for indoor use only and all the communication wirings are limited to indoor use as well.
3. NMS(Ethernet port)	Ethernet port for upper network The supporting network mode is UDP protocol
4. MDBU LED	LED to show whether MDBU is installed and is operating properly
5. RF Monitor Port	20dB Coupling compared with TX Input Level 20dB Coupling compared with RX Output Level
6. Pwr Test Port & ALM	Output DC power test port and ALM LED to show abnormal state, if any
7. Power switch	Power ON/OFF switch

2) Rear panel

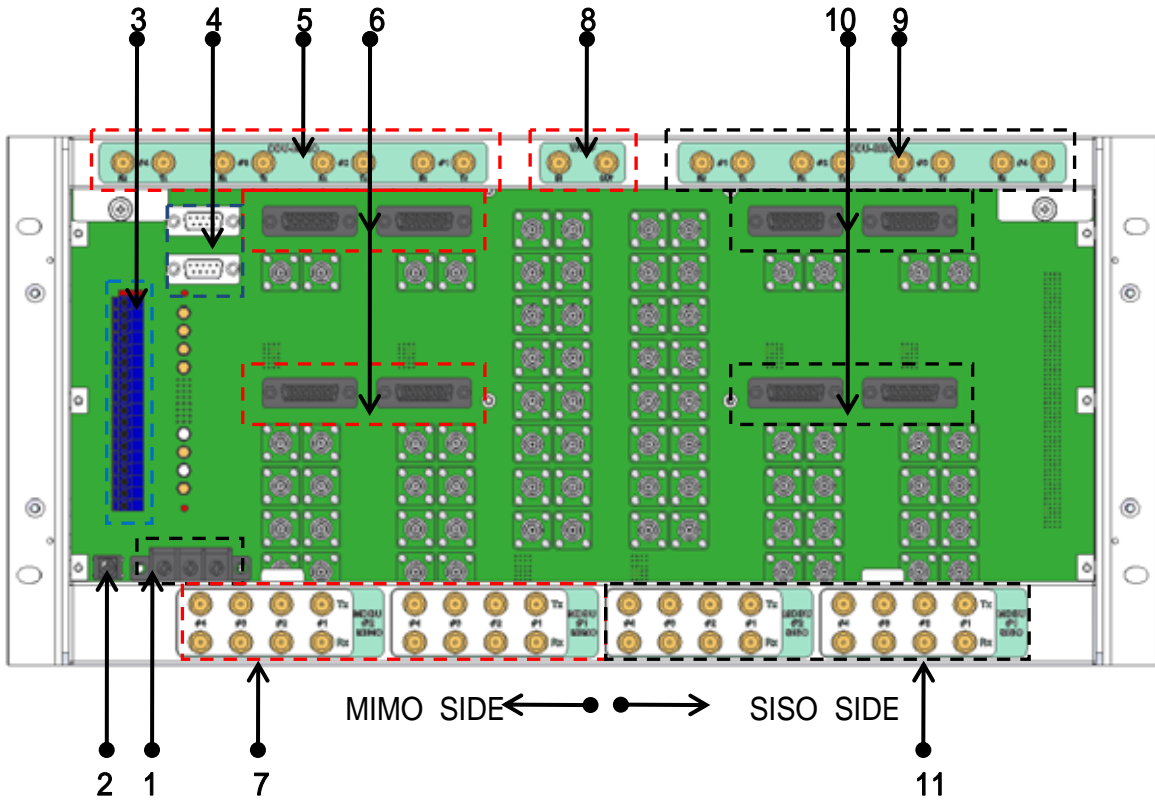

Figure 4.9 – Rear panel view

Item	Description
1. DC Input Port	Input terminal for DC -48V
2. External ALM Port	Input/output terminal for dry contact
3. GND Port	System ground terminal
4. AUX I/O Port	Reserved Port for future uses
5. MIMO ODU I/O Port	RF signal interface terminal for ODU
6. MIMO ODU signal Port	Power and signal interface terminal for ODU
7. MIMO BTS/BDA I/O Port	Input/output interface terminal of BTS/BDA
8. V/UHF I/O Port	RF signal interface terminal of VHF&UHF
9. SISO ODU I/O Port	RF signal interface terminal for ODU
10. SISO ODU signal Port	Power and signal interface terminal for ODU
11. SISO BTS/BDA I/O Port	Input/output interface terminal of BTS/BDA

4.2 ODU (Optic distribution Unit)

ODU receives TX RF signals from upper BIU and converts them into optical signals. The optical signals are sent to ROU through optical cables. This unit converts optical signals from ROU into RF signals and sends the converted signals to BIU.

For each shelf of the ODU, up to two DOUs (Donor Optic Unit) can be installed in it.

One DOU is supported with four optical ports. Therefore, one ODU can be connected with eight ROUs.

Up to four ODUs can be connected with BIU each SISO and MIMO path

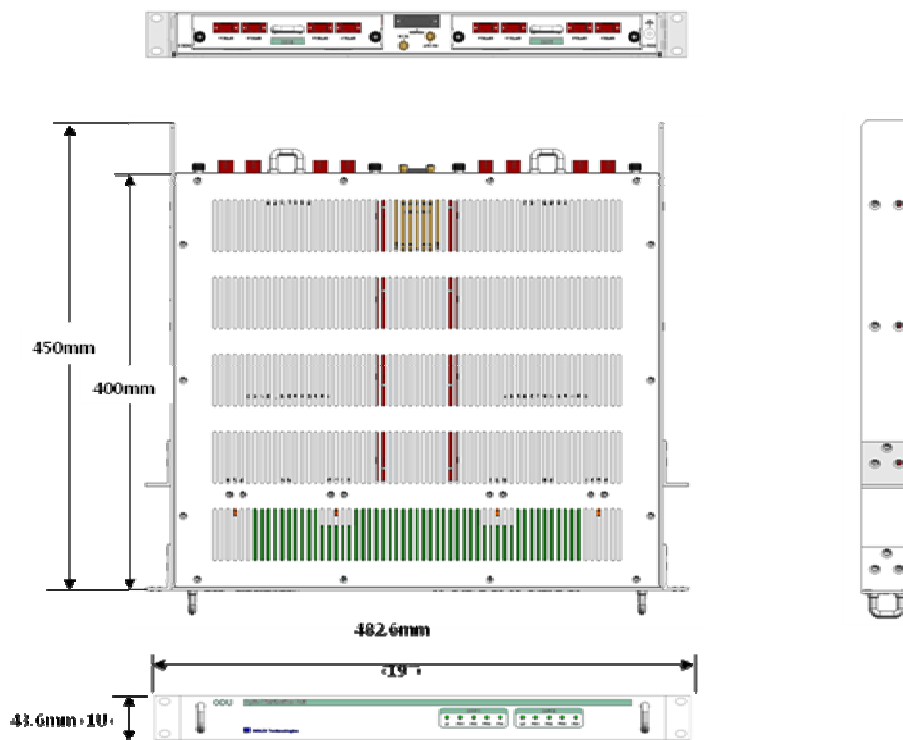

Figure 4.10 – ODU at a glance

4.2.1 ODU specifications

Item	Spec.	Remark
Size	482.6(19") x 43.6(1U) x 450	mm
Weight	6 kg	Full Load
Power consumption	27 W	

4.2.2 ODU block diagram

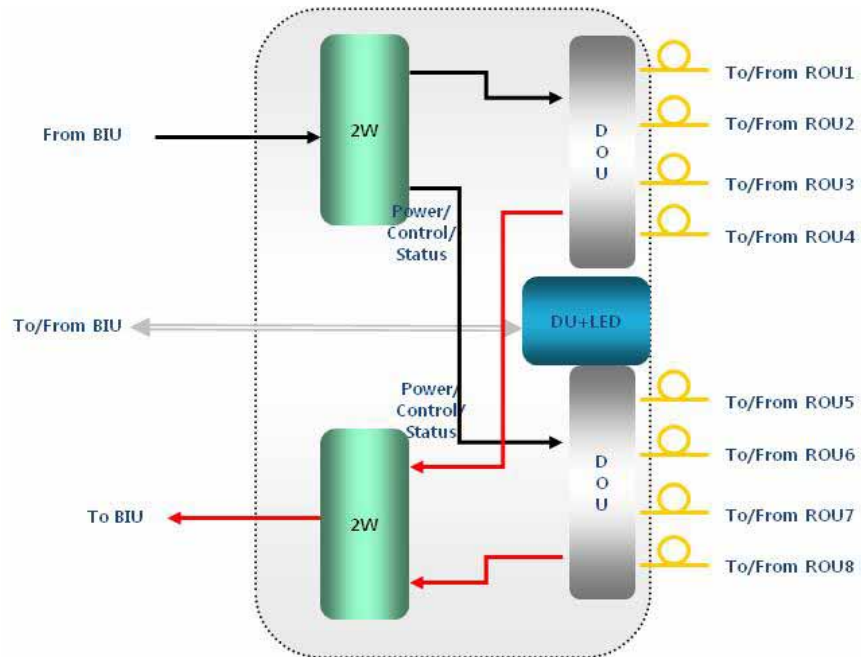

Figure 4.11 – ODU block diagram

4.2.3 ODU assemblies

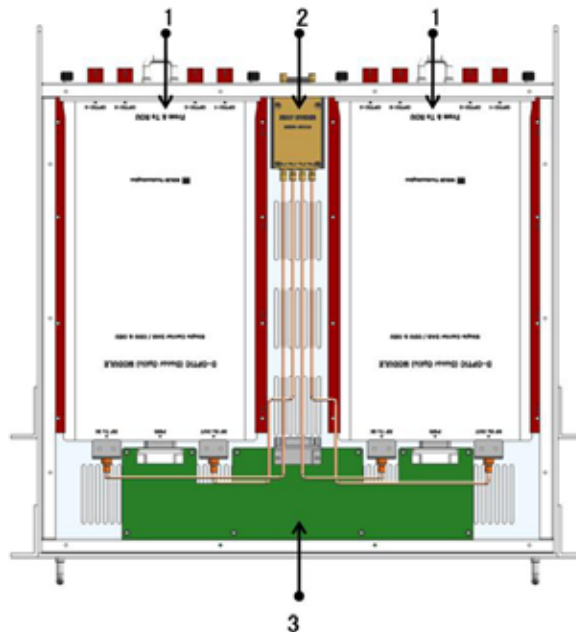

Figure 4.12 – ODU Internal View

No.	Unit	Description	Remark
1	DOU	Donor Optic Unit Converts TX RF signals into optical signals; Converts RX optical signals into RF signals; Provides up to four optical ports per DOU	Max 2 ea.
2	2W	2Way Divider Divides TX RF signals into two; Combines two RX RF signals into one	
3	DU	Distribution Unit Distributes power and signals to DOU	
4	Shelf	19" rack, 1RU	
5	Accessories	25PIN DSUB, Male to female 1pcs RF Coaxial Cable Assembly 2pcs	

4.2.4 Sub Assembly description

1) Donor Optic Unit (DOU)

The DOU performs the RF to optical conversion of TX signals as well as the optical to RF conversion of RX signals.

Using an optical splitter, this unit divides optical signals from a Laser Diode into four and then distributes them to each optical port. With a total of four Photo Diodes in RX, the DOU performs the optical to RF conversion of signals received from each optical port. In addition, the unit is equipped with an ATT to compensate for optical loss in the fiber or fiber connectors.

Since it uses a WDM, it uses only one strand of fiber for each ROU it connects to.

With internal FSK modem, it will allow operation from a remote site.

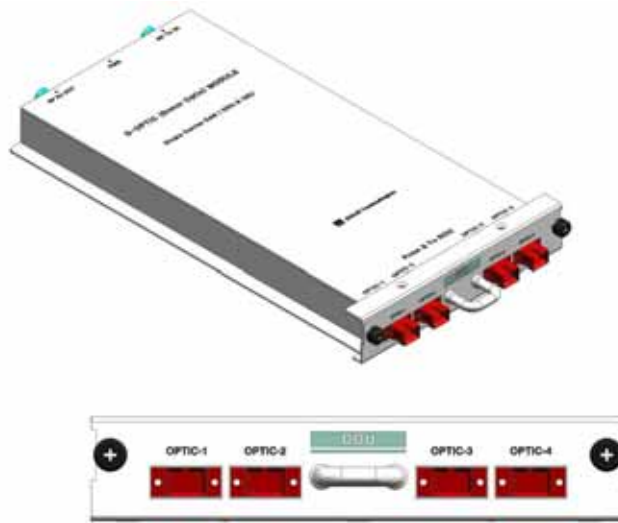

Figure 4.13 – DOU at a glance

2) 2Way Divider (2W)

The 2 way divider is equipped with two 2-way splitters in a single housing and the splitters work for TX/RX signals, respectively.

Designed in broadband type, the divider combines and splits signals from/to the BIU

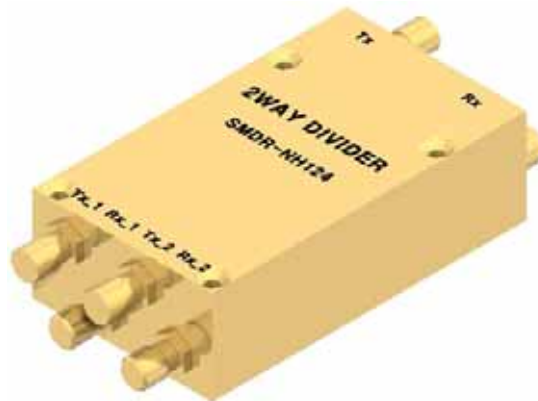

Figure 4.14 – 2Way Divider at a glance

4.2.5 ODU front/rear panel overview

1) Front panel

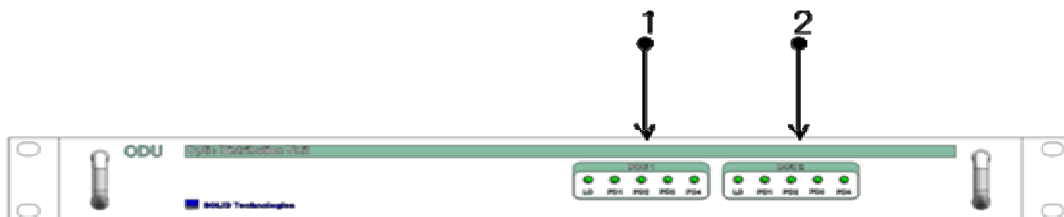

Figure 4.15 – ODU front panel view

Item	Description
1,2	LED indicator to check for faulty DOU module.

2) Rear panel

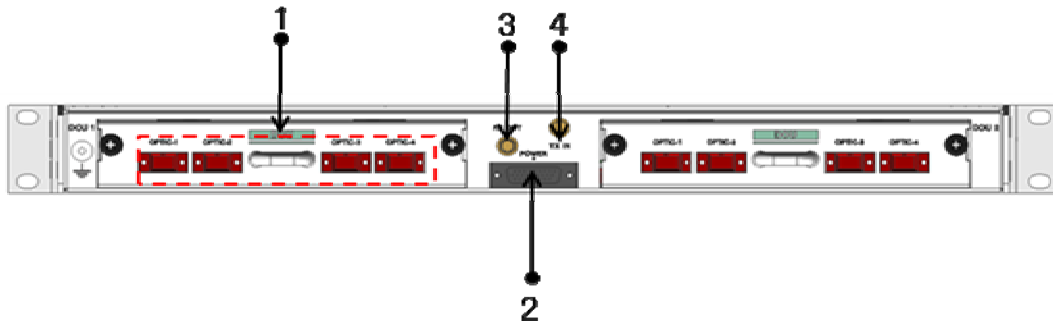

Figure 4.16 – ODU Rear panel view

Item	Description
1. Optic Port	SC/APC optical connector terminal; use one optical cable per ROU.
2. DC I/O Port	Terminal for power and state values
3. RX RF Port	RX RF signal interface terminal
4. TX RF Port	TX RF signal interface terminal

4.2.6 ODU Interface with BIU

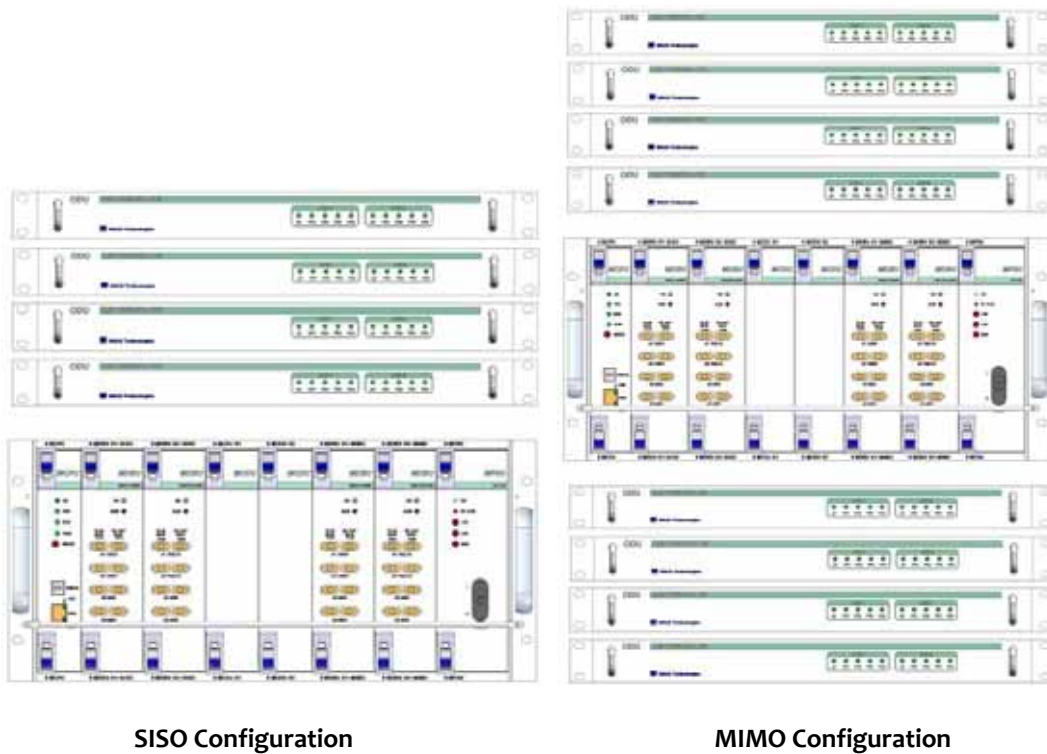

Figure 4.17 BIU/ODU interface

For SISO configuration, up to four ODUs can be stacked above the top of the BIU.
 For MIMO configuration, up to eight ODUs can be stacked above/below the BIU.
 In this case, it is recommended to leave a 1RU space between BIU and the ODUs otherwise heat from BIU may degrade the performance of the ODUs,

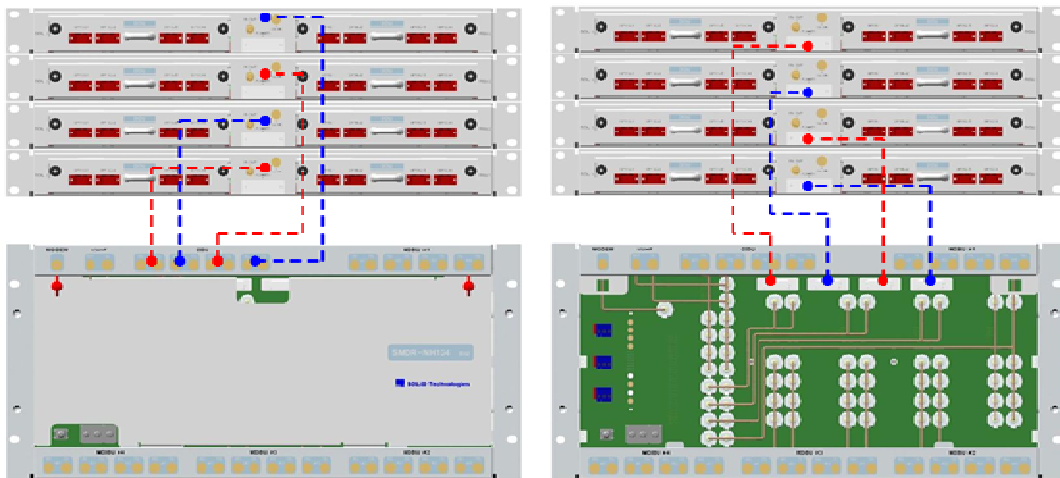

Figure 4.18 – BIU/ODU Interface rear view

As shown in the figure below, connect one coaxial cable for TX and another coaxial cable for RX with corresponding ports at the rear of BIU. For power supply and communication, connect 25Pin D-Sub Connector cable to the corresponding port.

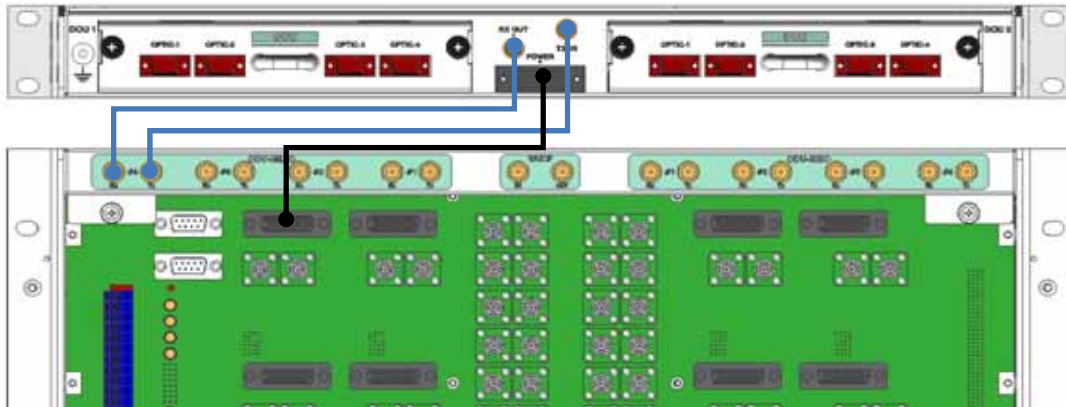

Figure 4.19 – BIU/ODU interface details

4.3 OEU (Optic Expansion Unit)

OEU is mainly used to remotely deliver signals for Campus clusters. At the upper part, this unit combines with ODU and receives TX optical signals to convert them into RF signals. Then, it regenerates the signals to secure SNR and converts them into optical signals. The signals are sent to ROU through optical cables. When it receives RX optical signals from ROU, the unit converts them into RF signals to regenerate the signals and then converts them into optical signals to send them to ODU.

In OEU, one shelf can be equipped with up to two DOUs. The DOU is the same as the module used for ODU. Up to four OEUs can be connected with ODU.

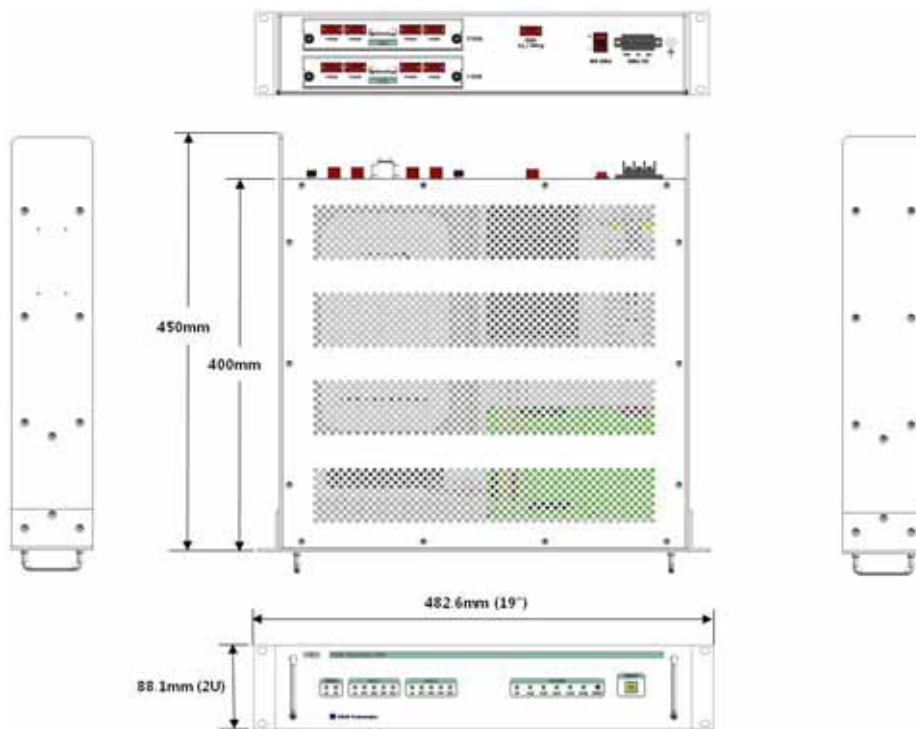

Figure 4.20 – OEU at a glance

4.3.1 Specifications of OEU

Item	Spec.	Remark
Size	482.6(19") x 88.1(2RU) x 450	mm
Weight	9.5 kg	Full Load
Power consumption	40 W	

4.3.2 OEU block diagram

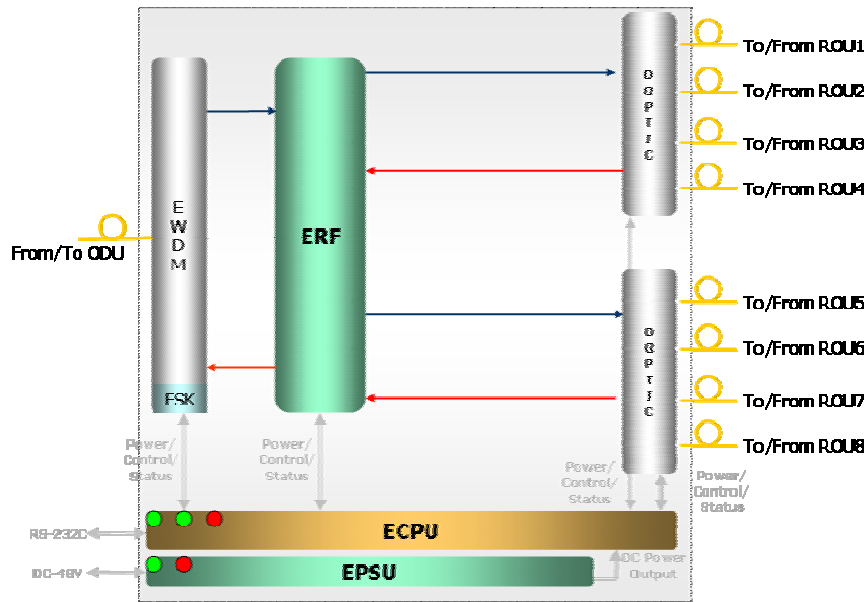

Figure 4.21 – OEU block diagram

4.3.3 OEU assemblies



Figure 4.22 – OEU internal view

No.	Unit	Description	Remark
1	DOU	Donor Optic Unit Convert TX RF signals into optical signals; Convert RX optical signals into RF signals; Provide up to four optical ports per DOU	Max 2 ea.
2	EWDM	Expansion Wavelength Division Multiplexer Convert TX optical signals into RF signals; Convert RX RF signals into optical signals; Compensates for optical cable loss with ODU	
3	ECPU	Expansion Central Processor Unit Control and monitoring system status Control and monitoring with RS232 Relays state values of ROU to BIU	
4	EPSU	Expansion Power Supply Unit Input power: DC -48V, Output power: 9V, 6V	
5	ERFM	Expansion Radio Frequency Module Regenerate TX signals and transmit FSK modem signals; Regenerate RX signals and receive FSK modem signals	
6	Shelf	19" rack, 2RU	

4.3.4 Sub Assembly description

1) Donor Optic Unit (DOU)

The DOU is the same as the module used for the ODU.



Figure 4.23 – DOU at a glance

2) Expansion Wavelength Division Multiplexer(EWDM)

EWDM module handles the optical to RF conversion of TX signals as well as the RF to optical conversion of RX signals. This multiplexer communicates with the BIU using the built in FSK modem. It also has an ATT to compensate for optical cable loss between ODUs. Finally , it has internal WDM so it needs only one optical cable to work with an ROU.



Figure 4.24 – EWDM at a glance

3) Expansion Central Processor Unit(ECPU)

ECPU can query and control the state of modules installed into the OEU. This unit simultaneously communicates with the BIU and the ROUs as well as acting as communication bridge between BIU and ROU.

In addition, the unit has a USB port for local communication which enables query and control of devices through a PC. At the front panel, communication LED indicator indicates communication with upper BIU and lower ROU. It also has an ALM LED indicator to show fault.

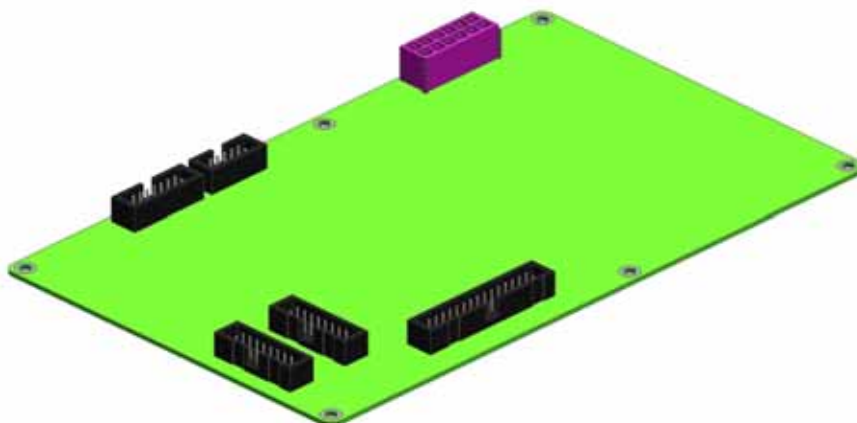

Figure 4.25 – ECPU at a glance

4) Expansion Radio Frequency Module(ERFM)

ERFM repairs Signal to Noise degraded by optical modules.

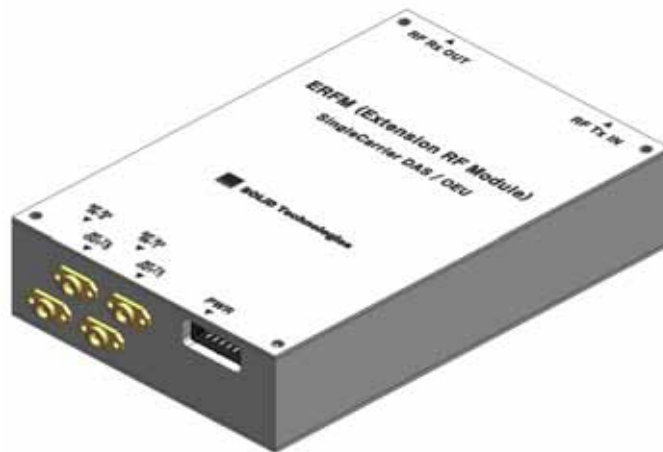

Figure 4.26 – ERFM at a glance

5) Expansion Power Supply Unit(EPSU)

As DC/DC Converter, the EPSU receives -48VDC input and provides +9V and +6V of DC power required for OEU.

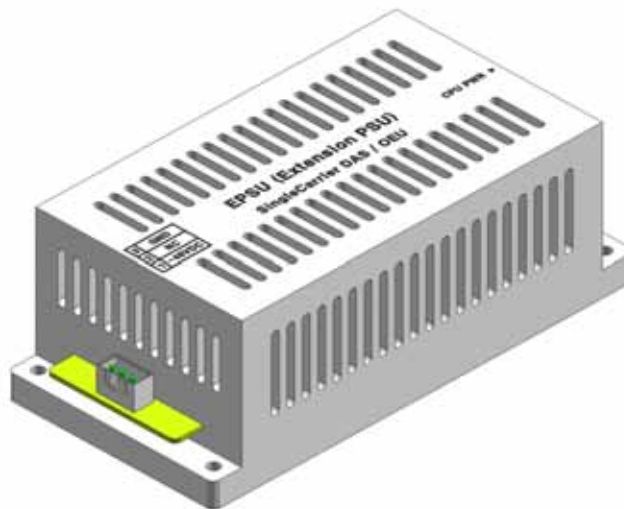

Figure 4.27 – EPSU at a glance

4.3.5 OEU front/rear panel overview

1) Front panel

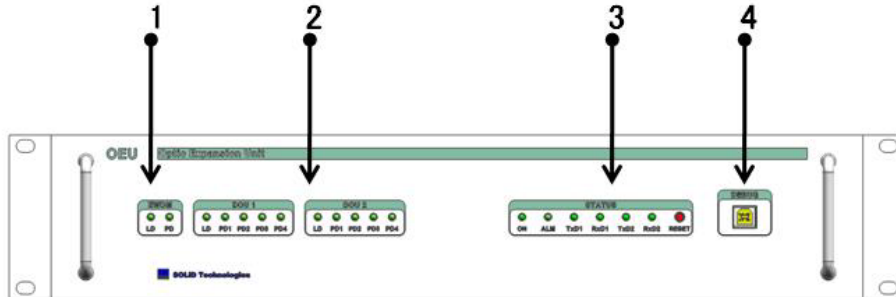

Figure 4.28 – OEU front panel view

Item	Description
1.EWDM LED	LED indicator to check EWDM state to see if it is abnormal
2.DOI LED	LED indicator to check DOI module state to see if it is abnormal
3.System LED and Reset	Communication state with devices, alarm status of the system and reset switch
4. NMS(USB Port)	USB port for communication and diagnosis of devices through PC/laptop. This equipment is for indoor use only and all the communication wirings are limited to indoor use as well.

2) Rear panel

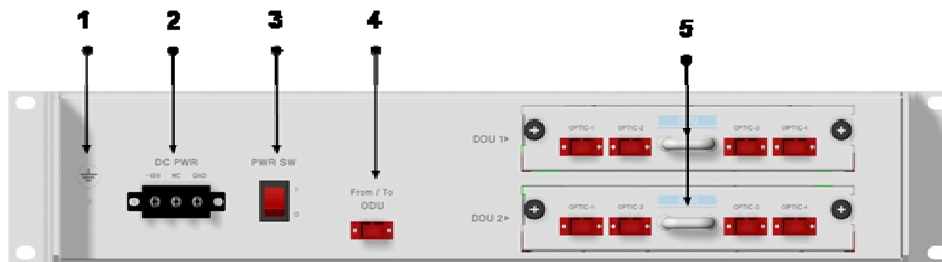

Figure 4.29 – Rear panel view

Item	Description
1. GND Port	Terminal for system ground
2. DC Input Port	Input terminal for DC -48V
3.power switch	Power ON/OFF switch
4. To/From ODU Optic Port	SC/APC optical connector terminal
5. To/From ROU Optic Port	SC/APC optical connector terminal; use one optical cable per ROU.

4.4 ROU (Remote Optic Unit)

The ROU consists of two units: the MRU(Main Remote Unit) and the ARU(Add on Remote Unit). The ROU is considered the combination of MRU and ARU.

The MRU receives TX optical signals from the ODU or the OEU and converts them into RF signals. The converted RF signals are amplified through a High Power Amp in a corresponding RU, combined with the Multiplexer and transmitted out the antenna port.

The ROU receives RX signals through the antenna port, filters out-of-band signals in a corresponding RU and sends the results to Remote Optic Module to make RF to optical conversion of them. After converted, the signals are sent to a upper device (the ODU or OEU).

The MRU and ARU have a maximum of 2 bands.

The main difference between an MRU and an ARU is the presence of an optical module .

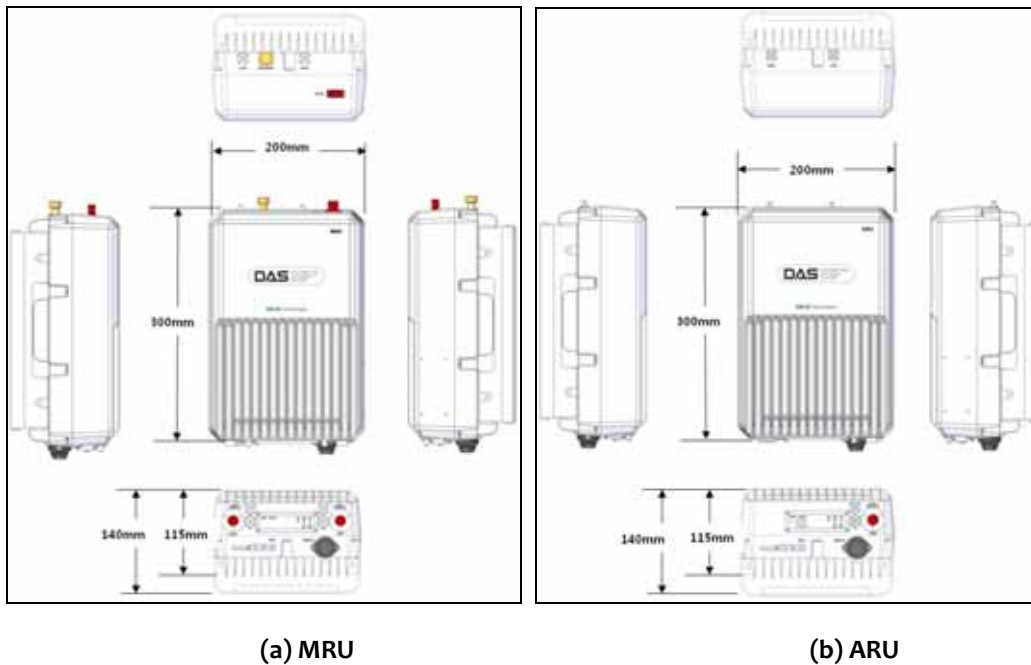

Figure 4.30 – ROU at a glance

4.4.1 ROU specifications

Item	Band combination	Size (W x H x D)	Weight	Power consumption	Remark	
Band Combination1	MRU 1900P+850C	200 x 300 x 140 mm	6.6kg	50W	Full load	
	ARU 700LTE+AWS-1		6.8kg	40W		
Band Combination2	MRU 1900P		6.5kg	45W		
	ARU 900I+800I		6.7kg	44W		
Band Combination3	To be developed					
	To be developed					

4.4.2 ROU block diagram

4.4.2.1 Combination of MRU 1900PCS+850C/ARU 700LTE+AWS-1

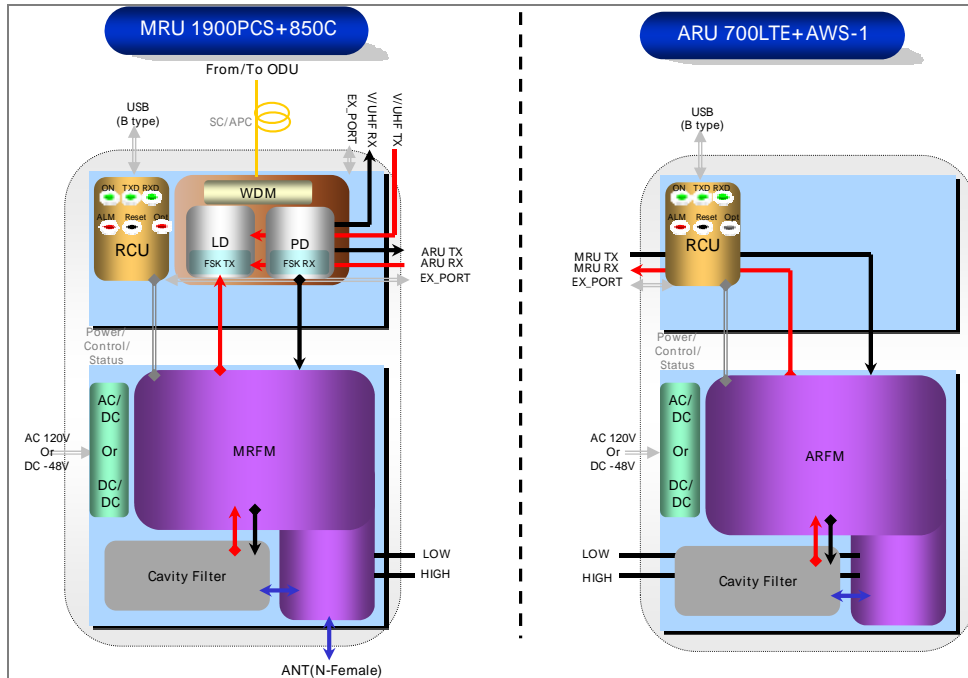

Figure 4.31 – ROU block diagram for MRU 1900PCS+850C and ARU 700LTE+AWS-1

4.4.2.2 Combination of MRU 1900PCS/ARU 900I+800I

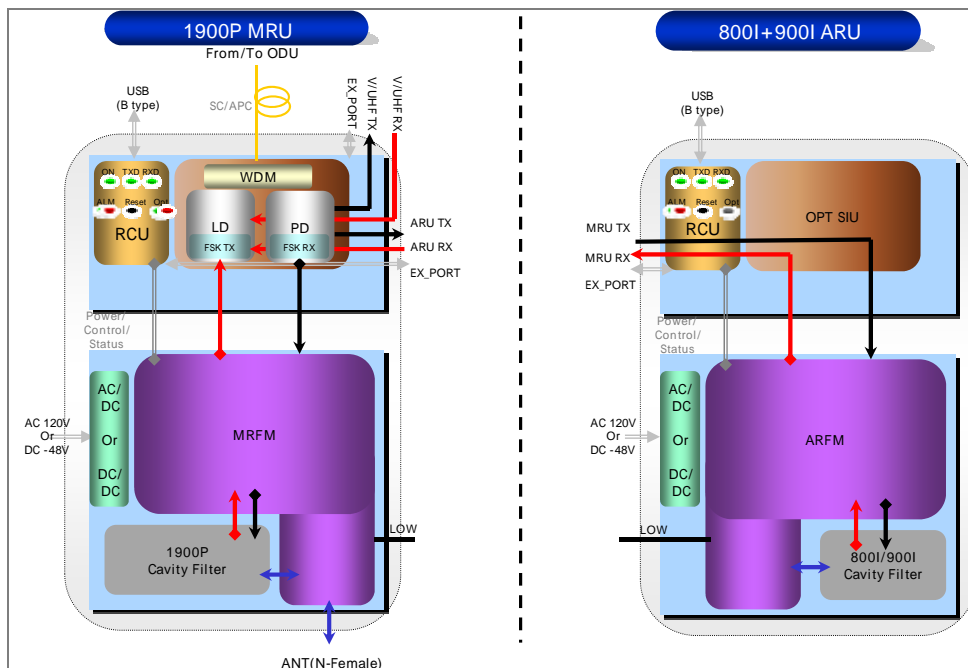
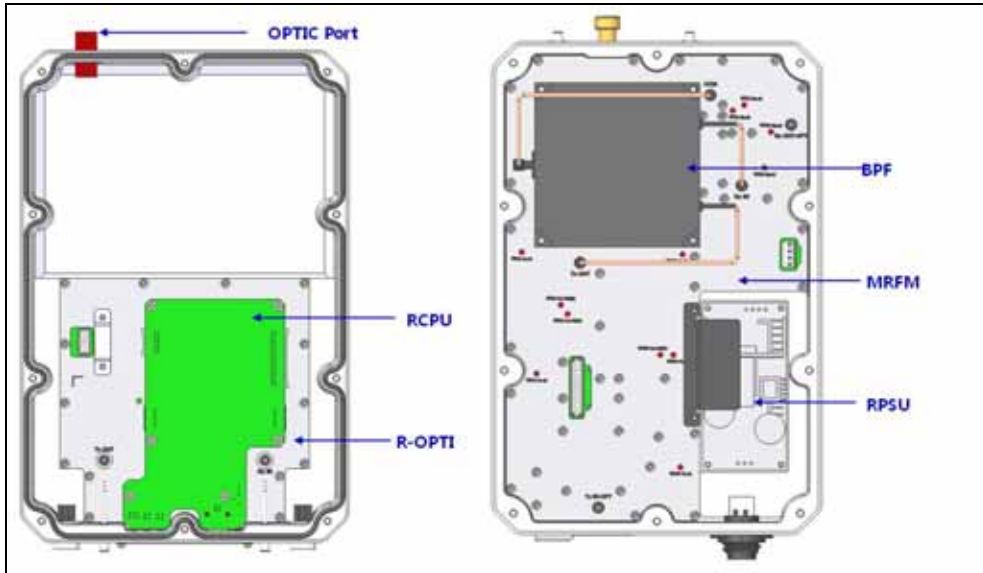

Figure 4.32 – ROU block diagram for MRU 1900PCS and ARU 900I+800I

4.4.3 ROU assemblies

4.4.3.1 Combination of MRU 1900PCS+850C/ARU 700LTE+AWS-1



(a) MRU 1900PCS+850C

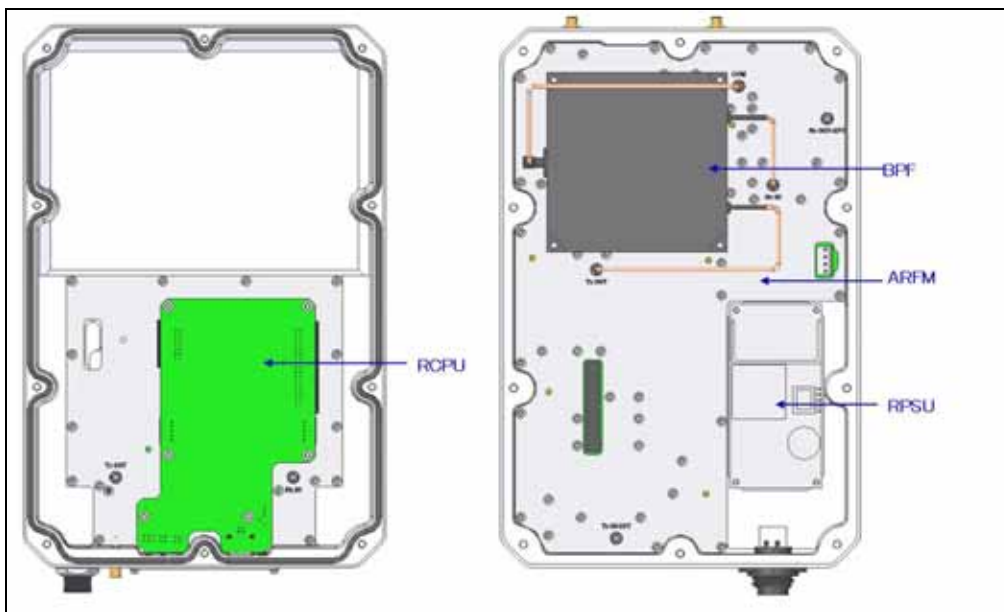

(b) ARU 700LTE+AWS-1

Figure 4.33 – ROU internal view for MRU1900PCS+850C and ARU 700LTE+AWS-1

4.4.3.2 Combination of MRU 1900PCS/ARU 900I+800I

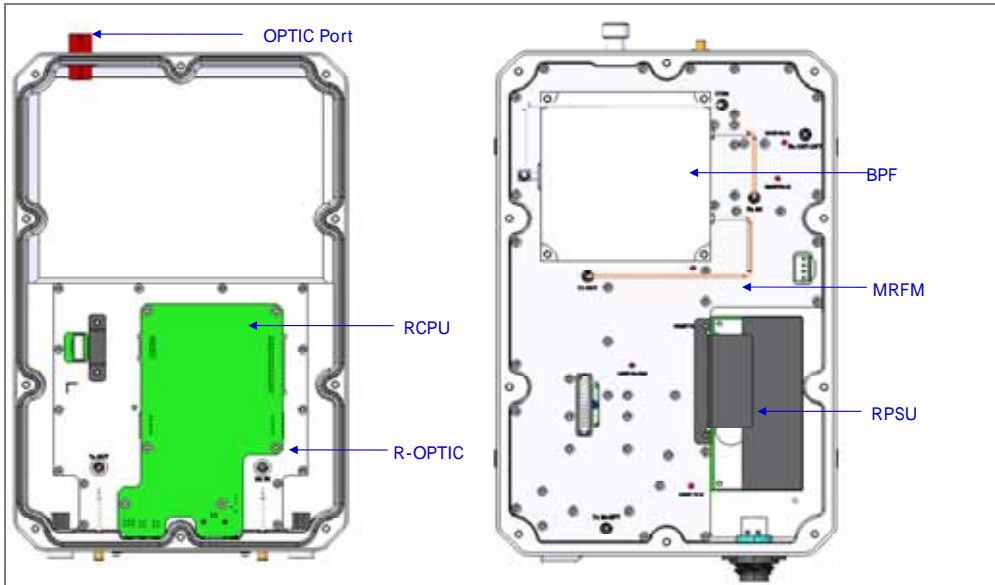

(a) MRU 1900PCS

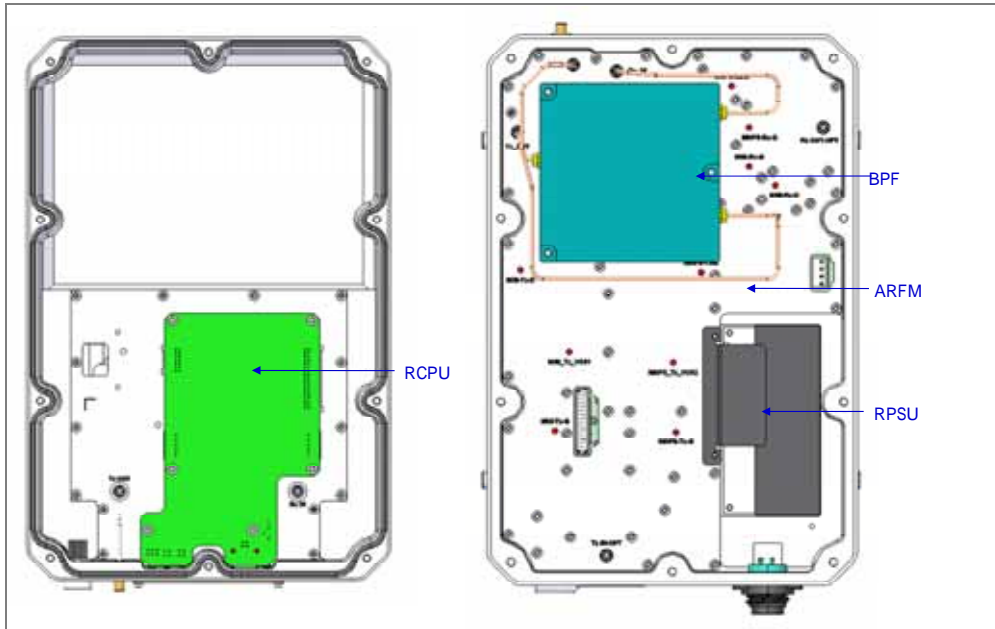

(b) ARU 900I+800I

Figure 4.34 – ROU internal view for MRU 1900PCS and ARU 900I+800I

No.	Unit	Description	Remark
1	MRFM/ARFM +BPF	Main/Add on RF Module Filter and heavy amplification of TX signals; Filter and amplify RX signals; Remove other signals through BPF	
2	RPSU	Remote Power Supply Unit Input power: DC -48V or AC120V, Output power: 25V For 120V input of AC/DC; For -48V input of DC/DC	
3	R-OPT	Remote Optic Make RF conversion of TX optical signals; Convert RX RF signals into optical signals; Compensates optical loss interval Communicates with BIU or OEU through the FSK modem	
4	RCPU	Remote Central Processor Unit Controls signal of each unit Monitors BIU/ODU/OEU status through FSK modem communication	
5	Enclosure	Enable Wall Mount; Check if the system is normal, through the bottom panel LED	

4.4.4 Sub Assembly description

1) Main RF Module/Add on RF Module (MRFM/ARFM)+BPF

When receiving TX signals from each band through R-Opt, MRFM/ARFM filters the signals and amplifies them with the High Power Amplifier. The unit also filters RX signals received through the antenna port and amplifies them as low noise to send the signals to R-Opt.

In the unit, there is an ATT to adjust gain. This device varies for each frequency band, including the following:

No	Combination	Unit naming	Description	BPF	
				Cavity Filter	Ceramic Filter
1	MRU1900P+850C	MRFM 1900P+850C	Dual.	1900PCS	850C
	ARU700LTE+AWS-1	ARFM 700LTE+AWS-1	Dual.	700LTE	AWS-1
2	MRU1900P	MRFM 1900P	Single	1900PCS	-
	ARU900I+800I	ARFM900I+800I	Dual	900IEN/800IDEN	-
3	To be developed	-	-	-	-

2) Remote Power Supply Unit (RPSU)

RPSU accepts -48VDC input. This unit is configured 2 ways: the DC/DC type outputs +25V of DC power and AC/DC type takes 120V AC input and outputs +25V of DC power.

Please specify which type when ordering. MS Connector, which uses ports to receive inputs, is designed for either AC and DC input configuration. The input cable is different depending on input voltage conditions.

The RPSU doesn't have a switch to turn the power ON/OFF. Unit is active when power is connected.

Here, you should check for range of input power as follows:

No.	Unit	Range of input power	Remark
1	AC/DC	90 to 264 VAC	
2	DC/DC	-42V to -56VDC	



(a)AC/DC

(b)DC/DC

Figure 4.35 – PSU at a glance

3) Remote Optic(R-OPT)

The Remote Optic performs the optical to RF signal conversion as well as the RF to optical conversion. With an FSK modem in it, the unit communicates with the other devices.

It also has an internal ATT to compensate for optical cable loss. The optical wavelength for TX path is 1310nm and 1550nm for the RX path. It is transported by a fiber strand using WDM(Wavelength Division Multiplexing) technique

4) Remote Central Processor Unit (RCPU)

The RCPU can monitor and control the RU. This unit receives and analyzes upper communication data from Remote Optic and reports the unit's own value to the upper devices. At the bottom of the module, it has an LED indicator to show system status, letting you check any fault conditions. The same panel also has communication LED Indicators to show communication status with upper devices. Through the USB Port, the unit enables you to check and control device status through a PC or laptop. This equipment is for indoor use only and all the communication wirings are limited to indoor use as well. The RCPU of the MRU have two ports to connect external devices (the ARU and the VHF&UHF ARU). Using an external interface cable, the MRU can communicate with the ARU/VHF&UHF ARU.

The MRU collects status information from ARU/VHF&UHF ARU and then communicates with the upper device

4.4.5 Bottom of ROU

1) Functions

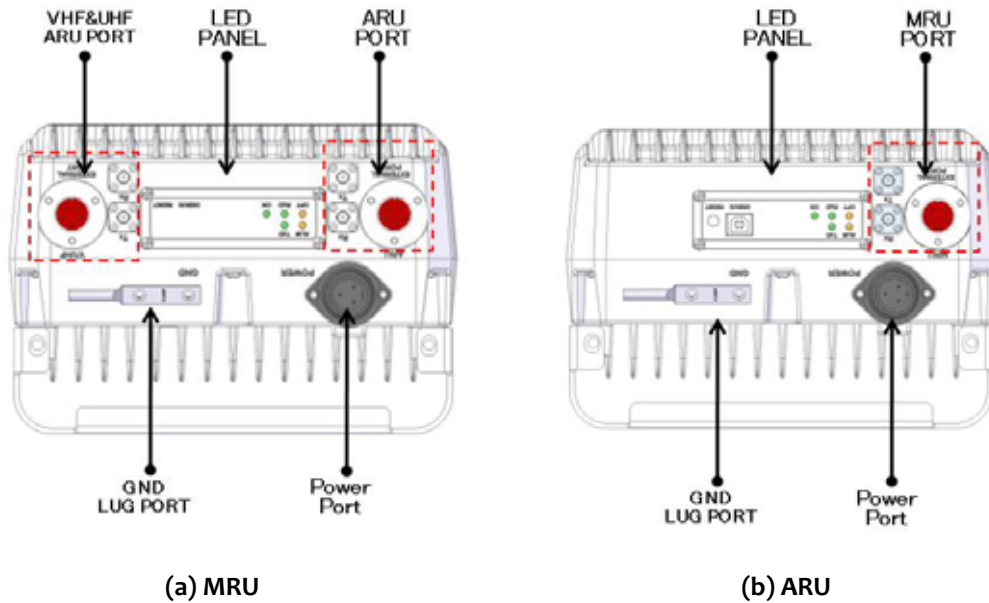
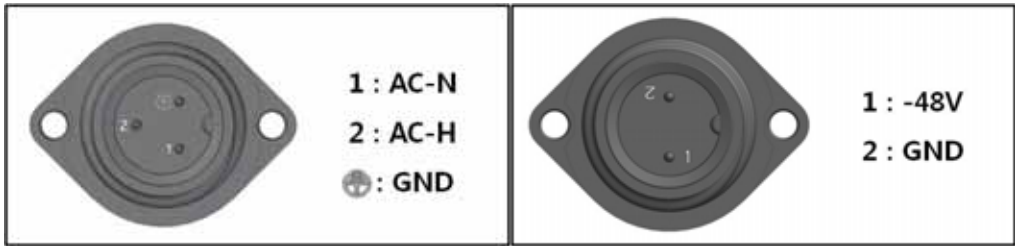

Figure 4.36 – ROU Bottom view

Item	Description	Remark
1. VHF/UHF ARU Port	Terminal for TX and RX RF ports of VHF and UHF Terminal for signal port to interface with VHF and UHF	
2.LED PANEL	Visible LED indicator panel for checking fault status USB Port to check and control device status through PC and laptop	
3. Power Port	AC 120V input port or DC-48V input port	
4.ARU/MRU Port	Terminal for TX and RX RF ports of MRU/ARU Terminal for signal port to interface with MRU/ARU	
5.GND LUG PORT	Terminal for system ground	

Power Port

A different type of power port is used supplying -48V DC or 120V AC, and specific power cable should be applied to each different type of ROU power supply (AC/DC or DC/DC). Below figure shows different power connectors.



(a)AC/DC

(b)DC/DC

Figure 4.37 – ROU Power Port View

4.4.6 Top of ROU

4.4.6.1 Combination of MRU1900PCS+850C/ARU700LTE+AWS-1

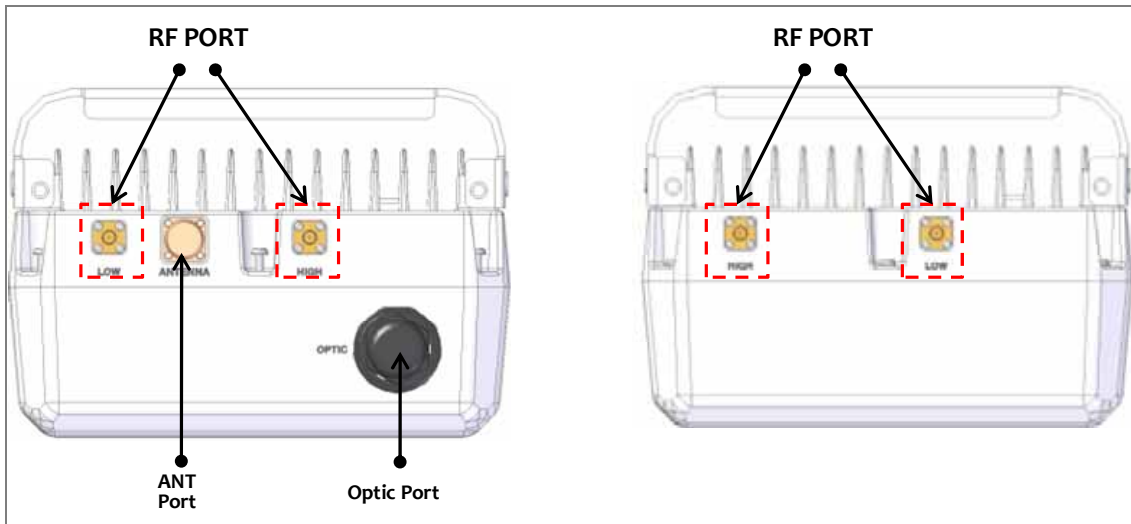

(a)MRU (b)ARU
Figure 4.38 – ROU Top View for MRU 1900P+850C and ARU 700LTE+AWS-1

4.4.6.2 Combination of MRU1900PCS+850C/ARU700LTE+AWS-1

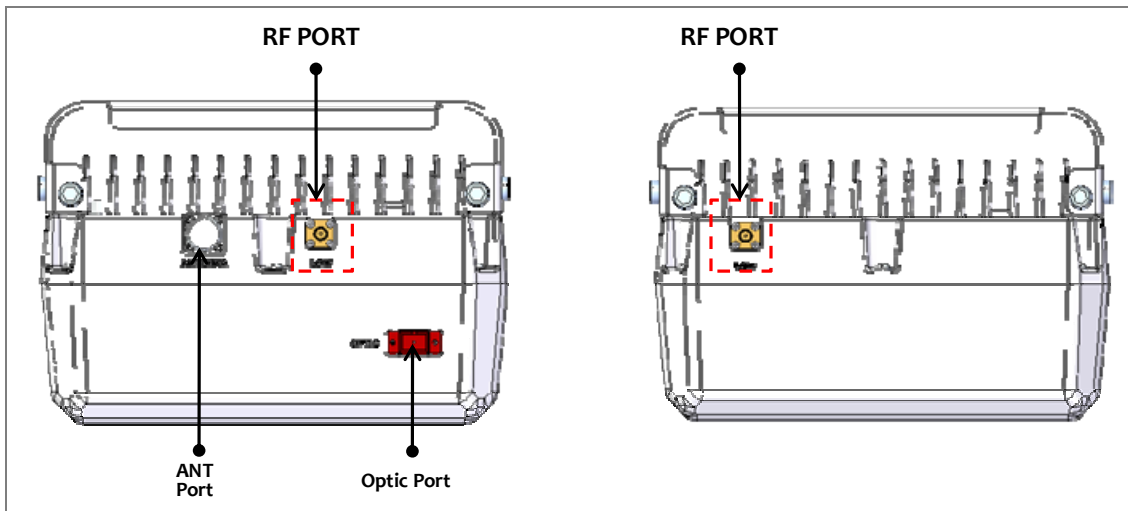

(a)MRU (b)ARU
Figure 4.39 – ROU Top View for MRU 1900P+850C and ARU 700LTE+AWS-1

Item	Description	Remark
1. RF Port	Terminal for Low RF port to connect between MRU and ARU RF Terminal for HIGH RF port to connect between MRU and ARU RF	
2. ANT Port	Terminal for RF port to connect to antenna	
3. Optic Port	Terminal for Optical port to connect with fiber cable The fiber connector type is SC/APC	

Section 5

System Installation & Operation

- 5.1 BIU Installation**
- 5.2 ODU Installation**
- 5.3 ROU Installation**
- 5.4 OEU Installation**

This chapter describes how to install each unit and corresponding fiber cables, along with power cabling method.

In detail, the chapter describes how to install shelves or enclosures of each unit, Power Cabling method, Optic Cabling and RF Interface. Furthermore, by showing power consumption of modules installed in each unit, a the Power Cabling budget is easily determined. Last, it describes the quantity of components of modules to be installed in each unit along with an expansion method.

5.1 BIU Installation

5.1.1 BIU Shelf Installation

Generally, the BIU is installed in a 19" standard rack. This unit has handles on each side for easy placement. With two mounting holes on each side, you can firmly fix the unit into a 19" rack.

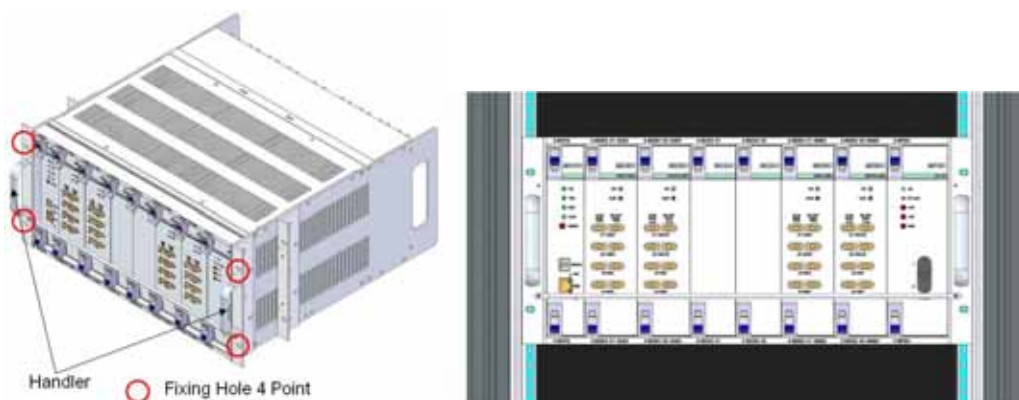

Figure 5.1 – RACK Installation

BIU has the following components:

No.	Unit	Description	Remark
Common Part	Shelf	Including Main Board, 19",5U	1EA
	MPSU	Operate -48Vdc Input	1EA
	MCPU	With Ethernet Port and USB Port	1EA
	Power Cable	-48Vdc Input with two lug terminal	1EA
SISO Slot	MCDU	-	1EA
	MDBU	Two among MDBU	Up to 2EA
MIMO Slot	MCDU	-	1EA
	MDBU	Two among MDBU	Up to 2EA

Basically, the frame of the BIU has slots equipped with an MPSU to supply devices with poweran

MCPU to query and control state of each module and a Power Cable to supply power from external rectifiers.

In addition, there are slots for the MDBUs which provide services for desired band (Optional) and the MCDU to combine and divide TX/RX signals for each SISO and MIMO slots

5.1.2 BIU Power Cabling

BIU requires -48VDC input power. Connect DC cable from the power supply to the Terminal Block seen at the rear of BIU.

Terminal	Color of cable	Description	Remark
-48V	Blue color	-	
GND	Black color	-	
NC	Not Connected	-	

Before connecting the power terminal, you need to connect "+" terminal of the DVM probe with the GND terminal and then connect "-" terminal with -48V to see if "-48Vdc" voltage is present. After confirming this, connect the power terminal with the terminal of the terminal block seen below.

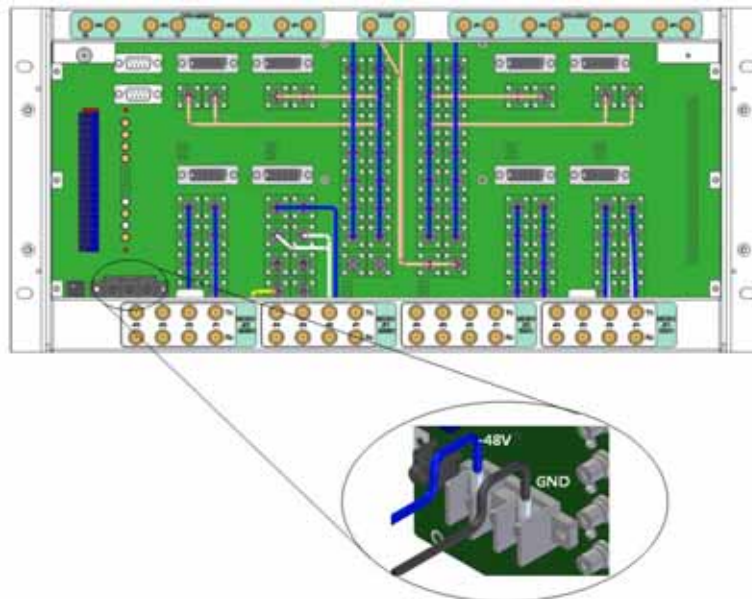

Figure 5.2 – Power interface diagram



Note that BIU does not operate if the "+" terminal and the "-" terminal of the -48V power are reversed.

When you connect -48V power to the BIU, use the ON/OFF switch of the MPSU located at the front of BIU to check the power.



Power Switch	LED		Description
O	ON	●	Abnormal, Not supply Power -48Vdc
		●	Normal supply power -48Vdc
	DC ALM	●	Normal Status
		●	Failure of output Power
I	ON	●	Normal Status
	DC ALM	●	

Figure 5.3 – PSU LED indicator information

5.1.3 BIU/RF interface

The BIU can be connected with a Bi-Directional Amplifier or Base Station Transceiver.

To connect the BIU with a BDA, you need to use a duplexer or a circulator to separate TX/RX signals from each other.

The BIU can feed external TX/RX signals from the Back Plane.

Using a dual band MDBU, the BIU can easily accommodate all frequency bands. As seen in the table below, the MDBU is divided into Single and Dual Band modules and each unit can be connected with two carrier signals per band. At the rear of the MDBU, 4 ports represent the inputs for the frequency bands. The following table shows signals to be fed to corresponding ports:

No	Unit naming	Description		In/out RF Port	
				TX	RX
1	1900P+850C MDBU	Dual Band 1900P:2Port 850C:2Port	Port#1	1900P TX(1930~1995MHz)	1900P RX(1850~1915MHz)
			Port#2	1900P TX(1930~1995MHz)	1900P RX(1850~1915MHz)
			Port#3	850C TX(869~894MHz)	850C RX(824~849MHz)
			Port#4	850C TX(869~894MHz)	850C RX(824~849MHz)
2	700LTE+AWS-1 MDBU	Dual Band 700LTE:2Port AWS-1:2Port	Port#1	700LTE TX(728~756MHz)	700LTE RX(698~716MHz, 777~787MHz)
			Port#2	700LTE TX(728~756MHz)	700LTE RX(698~716MHz, 777~787MHz)
			Port#3	AWS-1 TX(2110~2155MHz)	AWS-1 RX(1710~1755MHz)
			Port#4	AWS-1 TX(2110~2155MHz)	AWS-1 RX(1710~1755MHz)
3	1900P MDBU	Single Band 1900P:2Port	Port#1	1900P TX(1930~1995MHz)	1900P RX(1850~1915MHz)
			Port#2	1900P TX(1930~1995MHz)	1900P RX(1850~1915MHz)
4	900I+800I MDBU	Dual Band 900I:2Port 800I:2Port	Port#1	900I TX(935~940MHz)	900I RX(896~901MHz)
			Port#2	900I TX(925~940MHz)	900I RX(896~901MHz)
			Port#3	800PS TX(851~869MHz)	800PS RX(806~869MHz)
			Port#4	800PS TX(851~869MHz)	800PS RX(806~869MHz)
5	1900P+AWS-1 MDBU	Dual Band 1900P:2Port AWS-1:2Port	Port#1	1900P TX(1930~1995MHz)	1900P RX(1850~1915MHz)
			Port#2	1900P TX(1930~1995MHz)	1900P RX(1850~1915MHz)
			Port#3	AWS-1 TX(2110~2155MHz)	AWS-1 RX(1710~1755MHz)
			Port#4	AWS-1 TX(2110~2155MHz)	AWS-1 RX(1710~1755MHz)
6	700PS+800PS	Dual Band	Port#1	700PS TX(763~775MHz)	700PS RX(793~805MHz)

On the loadmap

	MDBU	700PS:2Port	Port#2	700PS TX(763~775MHz)	700PS RX(793~805MHz)
		800PS:2Port	Port#3	800PS TX(851~869MHz)	800PS RX(806~869MHz)
			Port#4	800PS TX(851~869MHz)	800PS RX(806~869MHz)
7	900I	Single Band	Port#1	900I TX(929~941MHz)	900I RX(896~902MHz)
	MDBU	900I:2Port	Port#2	900I TX(929~941MHz)	900I RX(896~902MHz)
8	VHF+UHF	Dual Band VHF+UHF : 1Port	Port#1	VHF Tx(136~174MHz)	VHF Rx(136~174MHz)
	MCDU			UHF Tx(380~512MHz)	UHF Rx(380~512MHz)

At the rear of BIU, Tx input and Rx output ports are seen for each MDBU. The name of all the ports are silk screened as "#1, #2, #3 and #4." From the table above, you need to feed correct signals to the input and output ports of the corresponding MDBU.

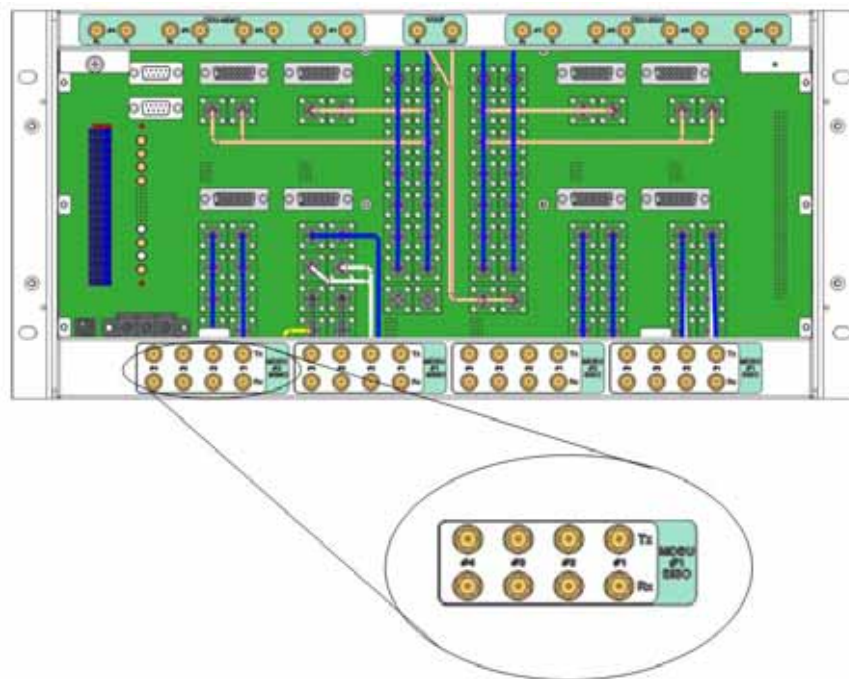

Figure 5.4 – BIU RF interface diagram

For each port, TX and RX signals are separated from each other. It is not necessary to terminate unused ports unless you want to.

BIU interface with Base station Transceiver

Basically, the BIU has separate TX and RX ports so you have only to connect the input and output

ports.

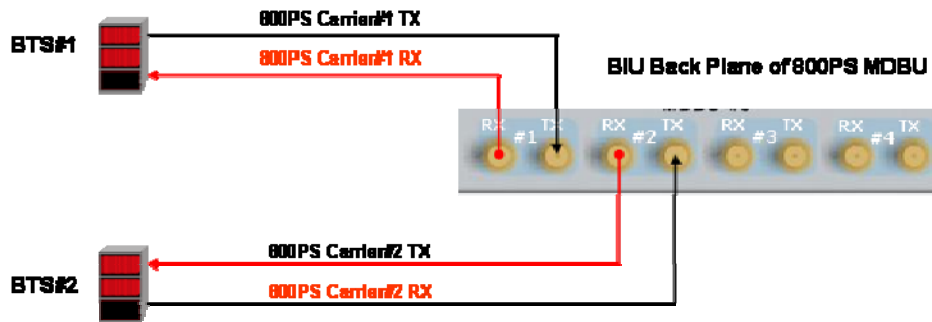

Figure 5.5 – BTS /BIU connections

Using a spectrum analyzer or power meter, you need to check signals sent from BTS TX. If the signals exceed input range (-20dBm~+10dBm), you can connect an attenuator between the BTS and BIU to bring the signal level into range.

BIU interface with Bi-Directional Amplifier

Since the BIU is Simplex format; you need to un-duplex the BDA signal to properly connect it to the BIU.

Using either duplexer or a circulator, you can separate TX/RX signals coming from the BDA

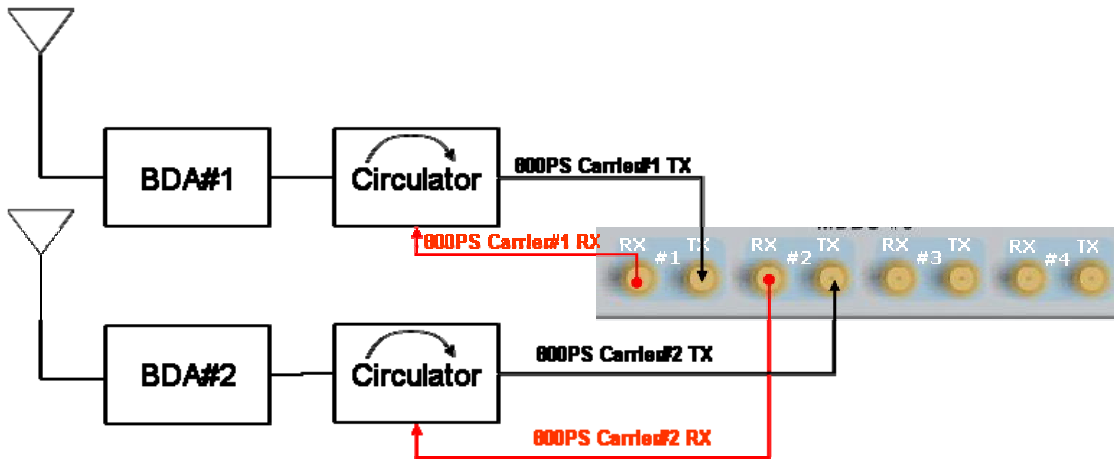

Figure 5.6 –BDA Interface using Circulator

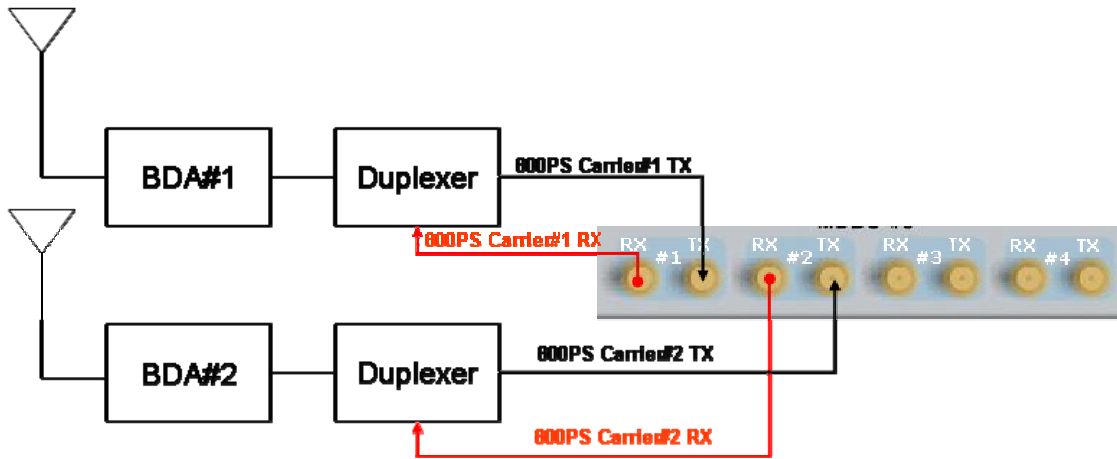

Figure 5.7 –BDA Interface using Duplexer

The BIU will work with the BDA in either of the methods above. TX signal level from the BDA must be verified that it is within range of the BIU.



Given the BIU TX input range (-20dBm~+10dBm/Total per port), verify it is within the input

range, before connecting the ports.

5.1.4 MDBU installation

MDBU is designed to be inserted into any slot.

A BIU can be equipped with a total of four MDBUs. If only one MDBU is inserted, you need to insert BLANK cards into the other slots.



If you do not terminate input and output ports of the MCDU, which combines TX signals and divides RX signals, it will cause out of band spurious signals. Make sure to insert MDBU BLANK cards

into the MDBU slots.

When an MDBU is inserted into the BIU, LEDs at the front panel will show the following information:

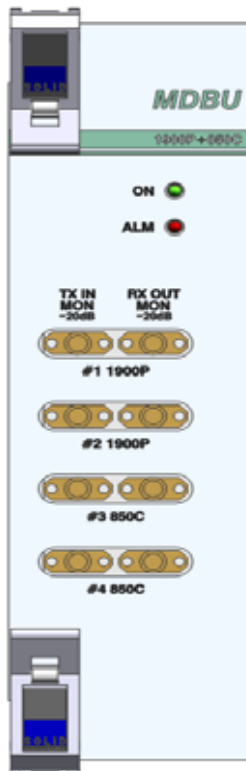

LED		Description
ON	●	Power is not supplied.
	●	Power is supplied.
ALM	●	Normal Operation
	●	Abnormal Operation

Figure 5.8 –MDBU LED indicator information

MONITOR SMA port seen at the front panel of the MDBU allows you to check the current level of TX input and RX output signals in service without affecting main signals.

TX MON is -20dB below TX Input power and RX MON is -20dB below RX Output power as well.

5.1.5 ODU Interface

The BIU supports up to four ODUs per platform. At the rear of BIU, eight RF input and output ports for the ODUs as well as four power ports for power supply and communication are provided. As you connect the ODUs, the BIU recognizes the ODU that is connected with BIU automatically

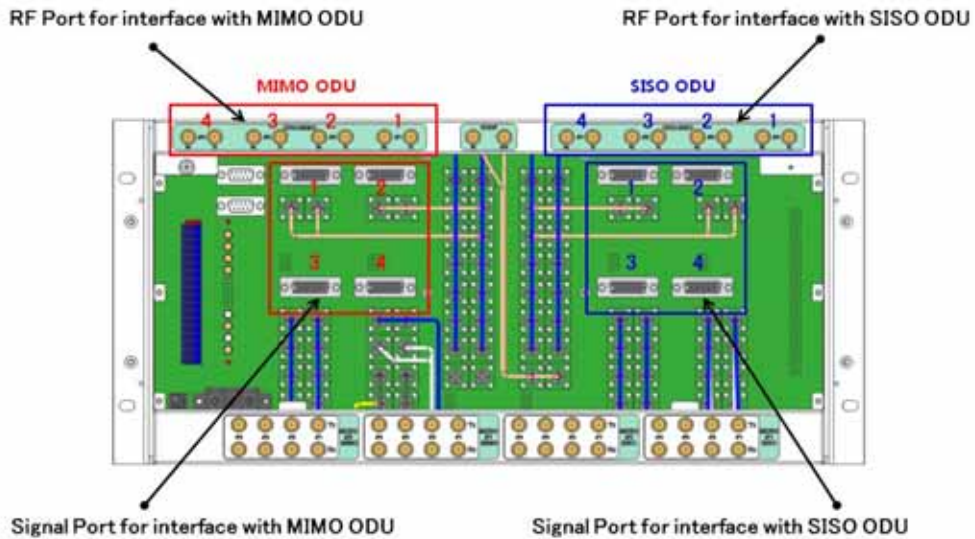

Figure 5.9 –Interface port between BIU and ODU

At the rear part of the ODU, the number of RF Ports and Signal Ports are printed in order. Its a good idea to label these in case additional ODUs are needed.

ODU Numbering		RF Port		Signal Port
		TX	RX	
ODU SISO	ODU 1	#1		SISO_ODU#1
	ODU 2	#2		SISO_ODU#2
	ODU 3	#3		SISO_ODU#3
	ODU 4	#4		SISO_ODU#4
ODU MIMO	ODU 1	#1		MIMO_ODU#1
	ODU 2	#2		MIMO_ODU#2

	ODU 3	#3	MIMO_ODU#3
	ODU 4	#4	MIMO_ODU#4

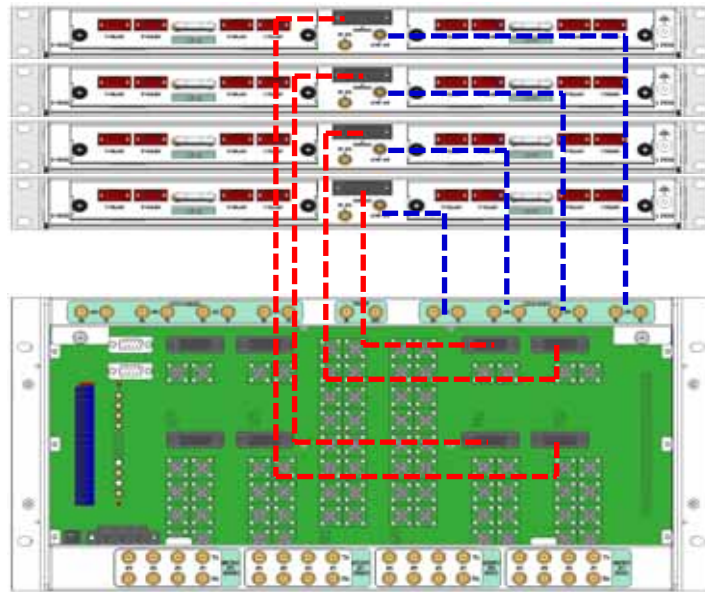

Figure 5.10 –Cabling interface diagram between BIU and ODU



For unused RF Ports for ODU expansion, make sure to terminate them using SMA Term.



When installing an ODU above the BIU, it is recommended to leave at least 1RU of space between the two. Heat from BIU rises and could damage the ODU.

5.1.6 BIU power consumption

The table below shows power consumption of the BIU:

Part	Unit	Consumption Power	Remark
Common Part	Shelf	4.8 W	
	MCPU		
	MPSU		
MCDU	-	2.4W	
MDBU	1900P+850C	16W	
	700LTE+AWS-1	16W	
	1900P	12W	
	900I+800I	16W	
	1900P+AWS-1	-	
	700PS+800PS	On the loadmap	
	900I	-	

The BIU supplies power for ODU. When you want to calculate total power consumption of the BIU, you need to add power consumption of the ODU to the total value.

Power consumption of ODU is given in the later paragraph describing ODU.

5.2 ODU Installation

ODU should be, in any case, put on the top of BIU. This unit gets required power and RF signals from BIU. The following table shows components of ODU:

No.	Unit	Description	Remark
Common Part	Shelf	Including Main Board, 19",1U	1EA
	RF Cable	SMA(F) to SMA(F), 400mm	2EA
	Signal Cable	3Row(26P_F) to 3Row(26P_M),650mm	1EA
Optional Part	DOU	Optical Module with 4 Optic Port	Up to 2EA to be inserted

5.2.1 ODU Shelf Installation

The ODU chassis is 1RU in height and 19" wide. It should be inserted into a 19" standard rack and placed above the BIU leaving a 1RU gap between the ODU and the BIU.

5.2.2 ODU Power Cabling

The ODU gets power from the BIU.

When you connect a 3-Row, 26-pin D-SUB Signal cable from BIU and install DOU, LED on the front panel is lit. Through this LED, you can check state values of LD and PD of DOU.

5.2.3 ODU Optic Cabling

The ODU makes RF-optical conversion of TX signals as well as optical-RF conversion of RX signals. The ODU can be equipped with up to two DOUs. One DOU supports four optical ports and one optical port can be connected with an ROU. Optionally, only optical port 4 can be connected with OEU for ODU1 and ODU2. ODU3. ODU4 can not connect with OEU.

As WDM is used in the DOU, the unit can concurrently send and receive two different wavelengths (TX:1310nm, RX:1550nm) through one strand of fiber. The DOU has SC/APC fiber connectors.



Figure 5.11 –SC/APC fiber termination

For optical adaptor, SC/APC type should be used. To prevent contamination of the fiber end, it should be covered with a cap when not installed. The SC/APC connectors should be cleaned with alcohol prior to installation.

5.2.4 DOU installation

Up to two DOUs can be installed in an ODU chassis. The DOU module is a Plug in Play type. When you insert a DOU in the ODU, insert the unit into the left DOU1 slot first. The slot number is silk screened at the left.

The following figure shows installation diagram of the ODU with one DOU inserted in it.



The following figure shows installation diagram of ODU with two DOUs inserted in it.



Figure 5.12 – ODU rear view with DOUs inserted



When you insert DOU into ODU, insert the unit into the left DOU1 slot first. Insert a BLANK

UNIT in the unused slot.

5.2.5 ODU Power consumption

The ODU gets power from the BIU. One ODU can be equipped with up to two DOUs. Depending on how many DOUs are installed, power consumption varies. The table below shows power consumption of the ODU:

Part	Unit	Consumption Power	Remark
ODU_4	DOU 1 EA	14W	

ODU_8	DOU 2 EA	28W	
-------	----------	-----	--

5.3 ROU Installation

5.3.1 ROU Enclosure installation

The ROU enclosure has two options. One meets NEMA4 standard and the other is not waterproof or dirtproof. The ROU can be mounted on a Wall easily. Rack mounting is also possible using special frame. There are 3 different types and they will be explained later in this chapter. The ROU consists of an MRU and an ARU. Their dimensions are the same.

The following shows the dimension of the mounting holes for the Wall Mount Bracket.

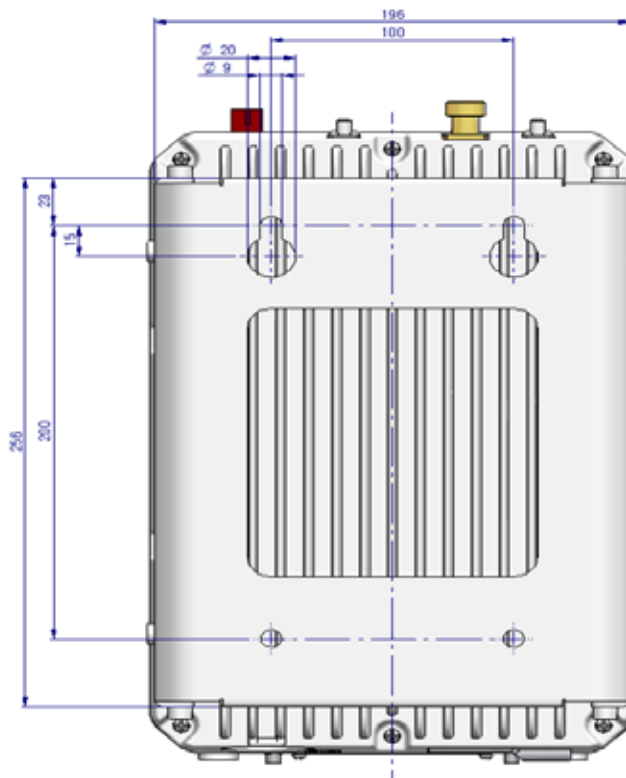

Figure 5.13 – Wall mount dimensions for the ROU

ROU Wall Mount Installation

There are two ways to install the ROU on the wall. One is to install ROUs on the wall side by side, the other is to stack the ARU above the MRU.

Type 1 : Side by Side installation

Install M8 mounting Screws roughly half way in, insert the wall mount bracket over the 2 screws and secure it with the last 2 screws.

For convenience, the Wall Mount Bracket has mounting holes to let you easily mount an enclosure.

Screw the M6 Wrench Bolts by half at each side of the Heatsink enclosure.

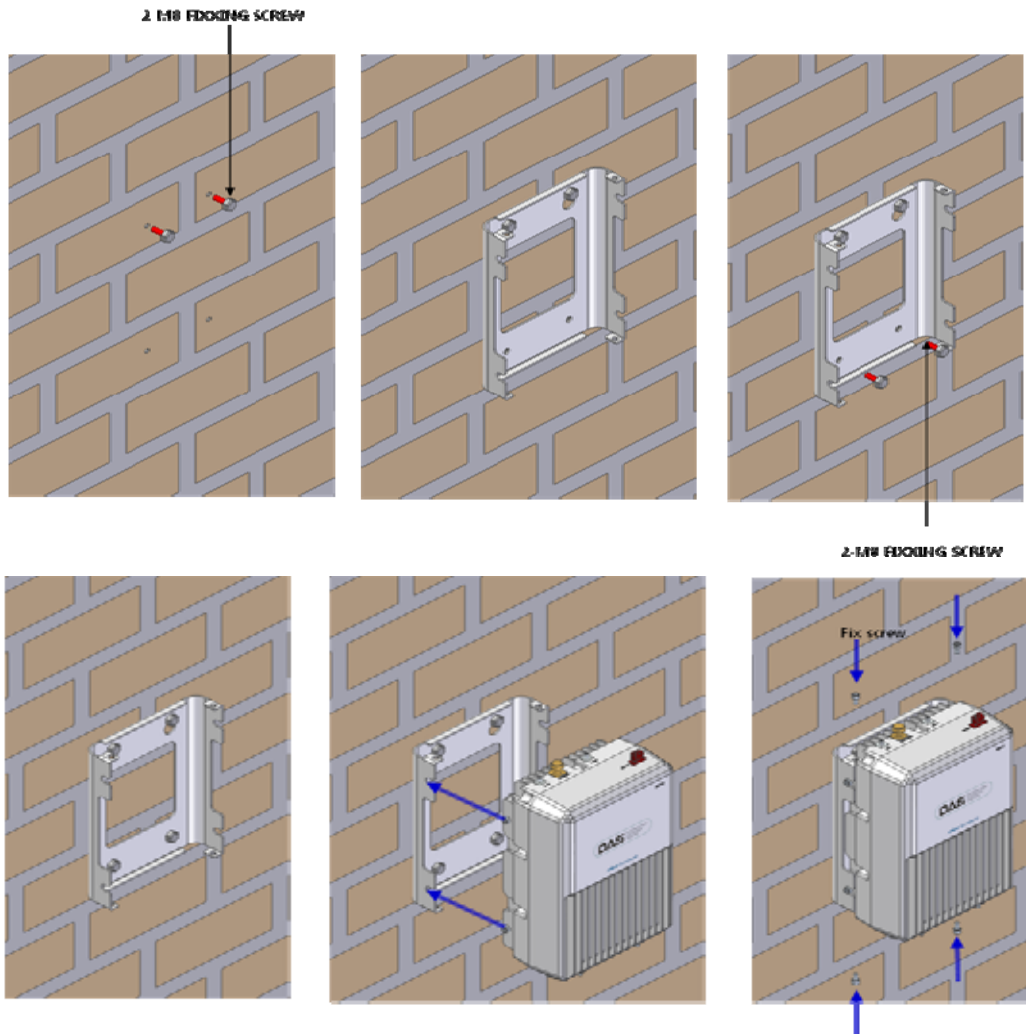

Figure 5.14 – ROU installation procedure side by side

Place the enclosure with the M6 Bolt on the mounting groove and mount the M6 Wrench Bolts into the remaining mounting holes.

In this case, you will use 4 M6 Wrench Bolts.

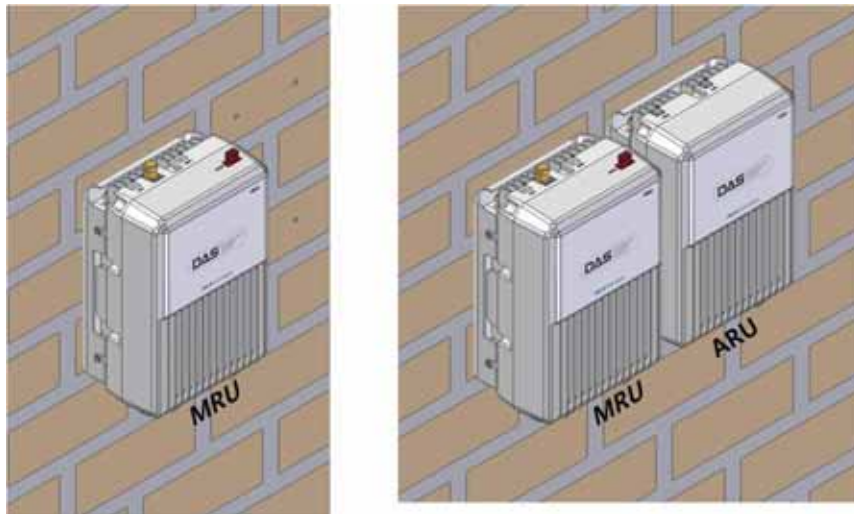

Figure 5.15 – ROU installation diagram side by side

For connecting cables between MRU and ARU easily, the MRU should install on left side of ARU.

Type2 : stacked installation

If space prohibits the MRU and ARU from being mounted side by side, the units can be installed in a stacked configuration.

Stacking the unit requires a special baracket for stacked installation

First, install the MRU on the wall , then install the bracket for stacked installation on the MRU. Finally install the ARU on the bracket.

Completed installation diagram is as follows

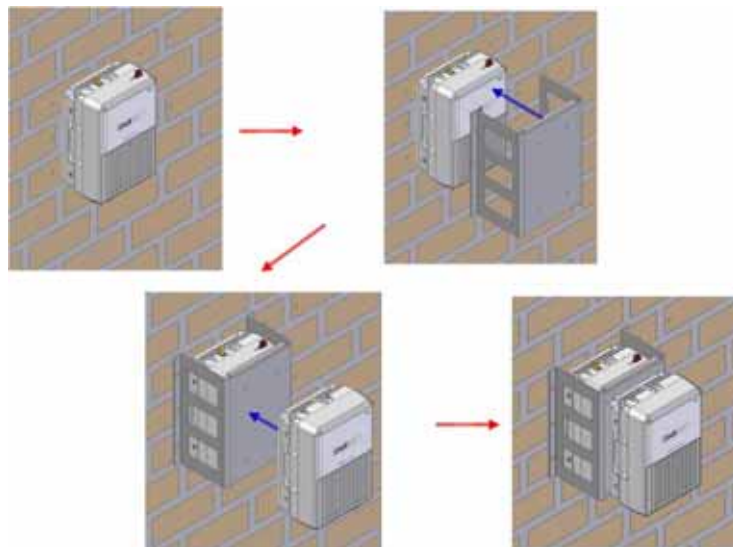

Figure 5.16 – ROU installation procedure for stacked mounting

The following shows dimension of the mounting point for the stacked bracket.

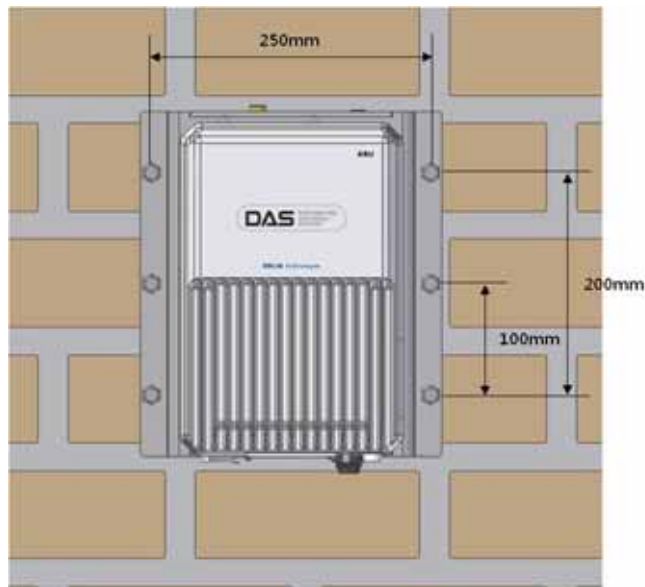

Figure 5.17 – ROU installation diagram for stacked mounting

ROU Rack Mount Installation

There are two ways to install rack mount. One is to install ROUs on the rack vertically: the other is to install ROUs on the rack horizontally

Type1 : Vertical installation on the rack

For vertical installation, a vertical bracket is needed.

First, install bracket for vertical installation on the rack

Second, mount MRU on the left side of the installed bracket

Third, mount ARU on the right side of the installed bracket

Completed installation diagram is as follows

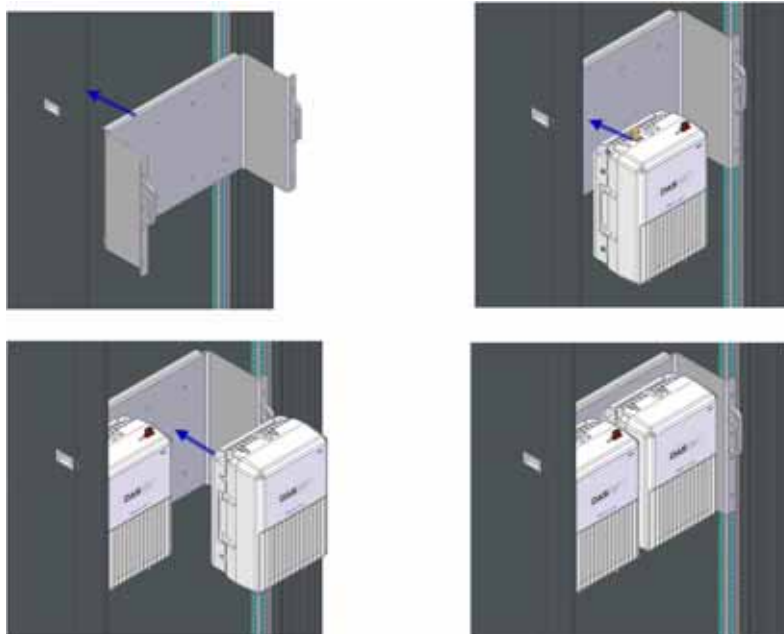

Figure 5.18 – ROU installation procedure for vertical rack

The following shows dimension of the mounting point for vertical installation

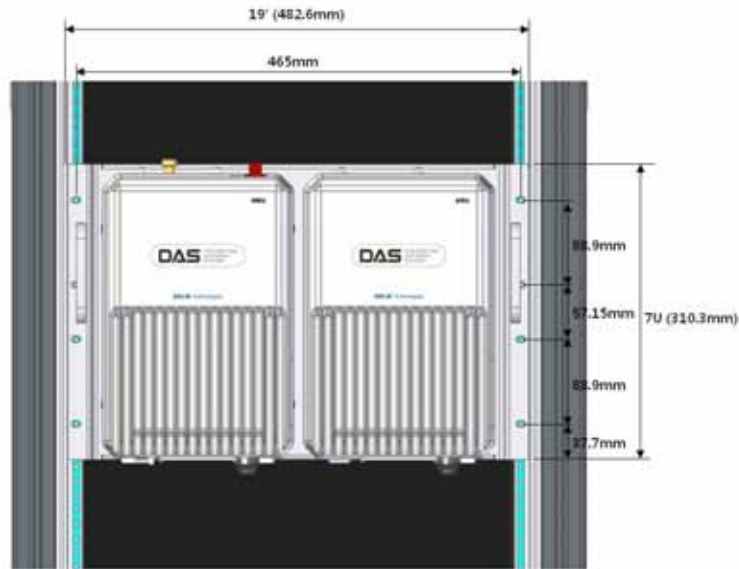

Figure 5.19 – ROU installation diagram for vertical rack

Type2 : Horizontal installation on the rack

For Horizontal installation, horizontal bracket is needed. Unlike vertical installation, the MRU is mounted on the right of the installed bracket first and then ARU is installed to the left of MRU

First, install bracket for horizontal installation on the rack

Second, open the front cover of horizontal bracket

Third, mount MRU on the right side of the installed bracket

Fourth, mount ARU on the left side of the installed bracket

Finally, close the front cover of horizontal bracket

Completed installation diagram is as follows

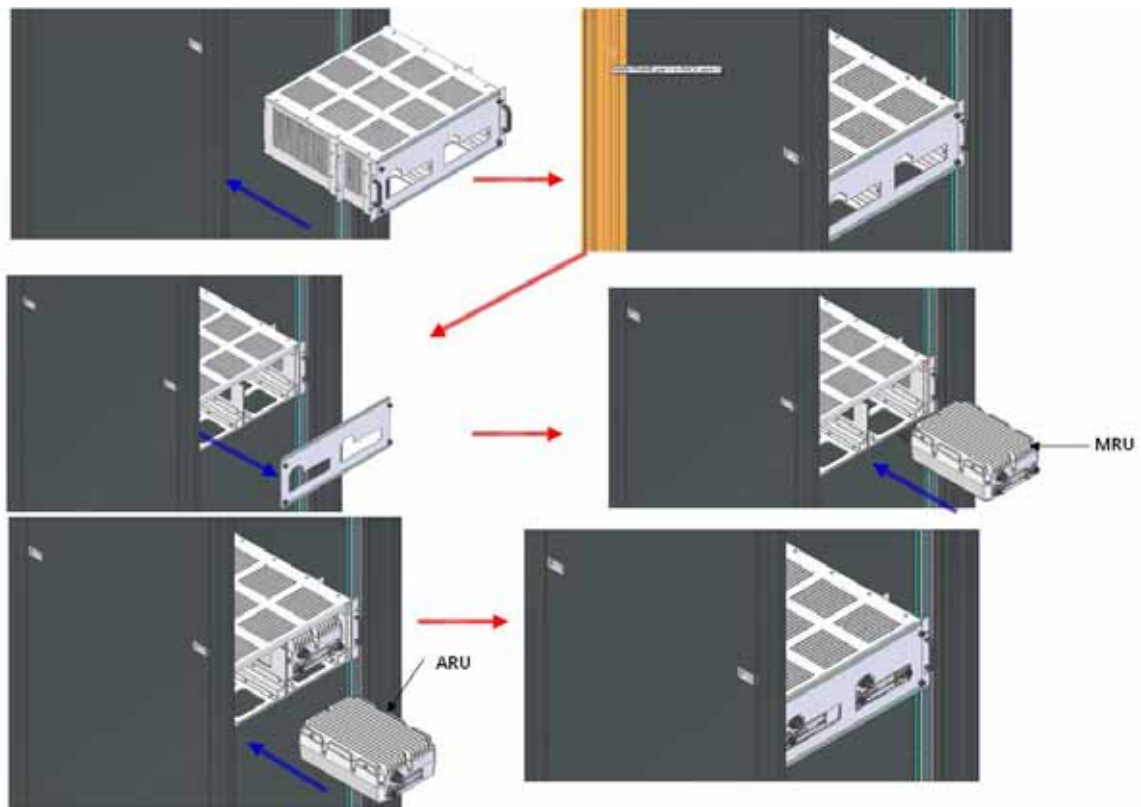

Figure 5.20 – ROU installation procedure for horizontal rack

The following shows dimensions of the mounting point for horizontal installation

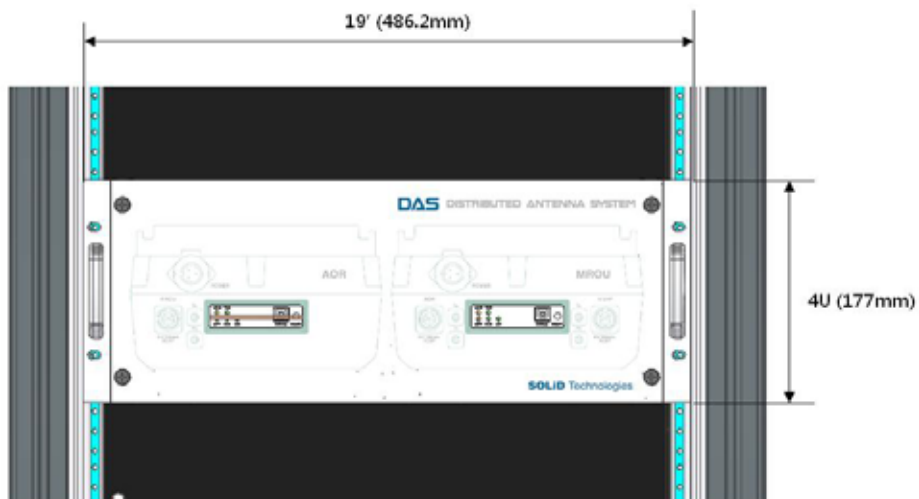

Figure 5.21 – ROU installation diagram for horizontal rack

ROU components

The ROU has the following components:

No.	Unit	Description	Remark
MRU	Enclosure	Including Wall cradle	1EA
	Power Cable	- Connector with 3 hole to AC 120 plug(AC) - Connector with 2 lug termination(DC)	1EA(Optical for AC or DC)
ARU	Enclosure	Including Wall cradle	1EA
	Power Cable	- Connector with 3 hole to AC 120 plug(AC) - Connector with 2 lug termination(DC)	1EA(Optical for AC or DC)
	RF cable for optical	- Two RF cables and one signal cable	
	RF cable for antenna	- Two RF cables	

5.3.2 ROU Power Cabling

The ROU supports both of DC-48V and AC120V input power. The type of input power for the ROU is already determined at the factory. The ROU is shipped with the correct power cable in the package box. See the UL name plate of the ROU to determine the input power type of the ROU or see the power connector in the below picture. You should order the type of input power as your application.

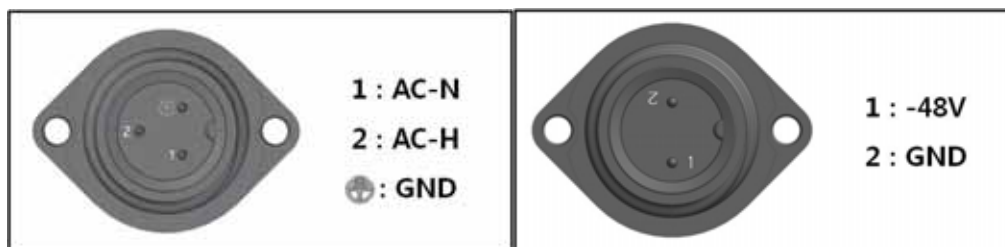

(a)AC/DC

(b)DC/DC

Figure 5.22 – ROU Power Port view

Check if your power cord connector is the same as one seen in the table above. The ROU does not have power switch to power on/off. Power supply is on when cord is plugged into the AC source.

5.3.3 Optical Cabling

The MRU makes the optical-RF conversion of TX signals from upper the ODU and OEU as well as the RF- optical conversion of RX signals. The MRU has one optical module in it. As WDM is used in the R_OPT module, two separate wavelengths (TX:1310nm, RX:1550nm) can be sent/received with one fiber strand at the same time. The MRU has SC/APC connectors.

To prevent the fiber interface from being marred with dirt, it should be covered with a cap when not installed. Fiber connectors should be cleaned alcohol to remove dirt before installation .

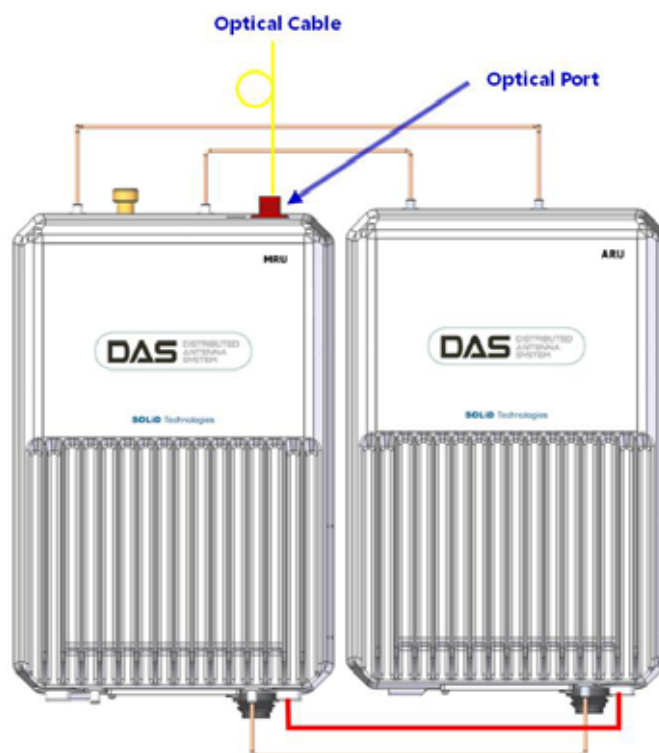

Figure 5.23 – ROU optical Port view

Only the MRU has optical port; there is no optical port on the ARU

5.3.4 GND Terminal Connection

The ROU has one GND terminal port on bottom side, as shown below

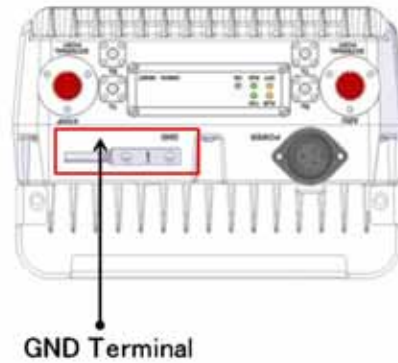

Figure 5.24 – ROU GND Port view

- Take off the GND terminal port from the enclosure and connect to the ground cable. Then reconnect it to the enclosure
- The opposite end of the ground cable should connect to the communication GND of building
- The ground lug is designed meeting the SQ5.5 standard

5.3.5 Coaxial cable and Antenna Connection

- The coaxial cables which are connected to DAS connect to antenna port of the ROU. Before connection, check the VSWR of the coaxial cable using a SiteMaster to verify whether it is within tolerance.
- The Return loss should be better than 15dB or VSWR should be below 1.5: 1.
- Make sure the antenna connector is tightened properly and free of any dirt or insects.
- The antenna connected to the ROU is only for inbuilding use.
- Only the MRU has an antenna port. The ARU transmits its signal through RF cable connected to both the MRU and ARU

5.3.6 LED explanation on ROU

The ROU has an LED panel at the bottom of ROU. The LED indicator is explained below

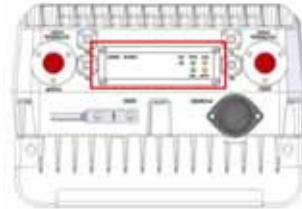

LED		Description
ON	●	Power is not supplied
	●	Power is supplied.
ALM	●	Normal Operation
	●	Abnormal Operation
OPT	●	R-OPT is normal operation
	●	R-OPT is abnormal Operation
TXD	●	Flashing when data send to upper unit
RXD	●	Flashing when data receive from upper unit

Figure 5.25 – ROU LED indicator information

5.3.7 ROU Power consumption

The following table shows power consumption of the ROU

Part	Unit	Consumption Power	Remark
MRU	1900P+850C supporting ARU 700LTE+AWS-1	50W	Dual Band
	1900P supporting ARU 900l+800l	45W	Single Band
ARU	700LTE+AWS-1	40W	Dual Band
	900l+800l	44W	Dual Band

5.3.8 Cable connection between MRU and ARU

MRU has only antenna port, ARU output port should be connected with MRU. MRU transmit all frequency band into one antenna after combining with ARU signal

Figure below shows connection diagram between MRU and ARU

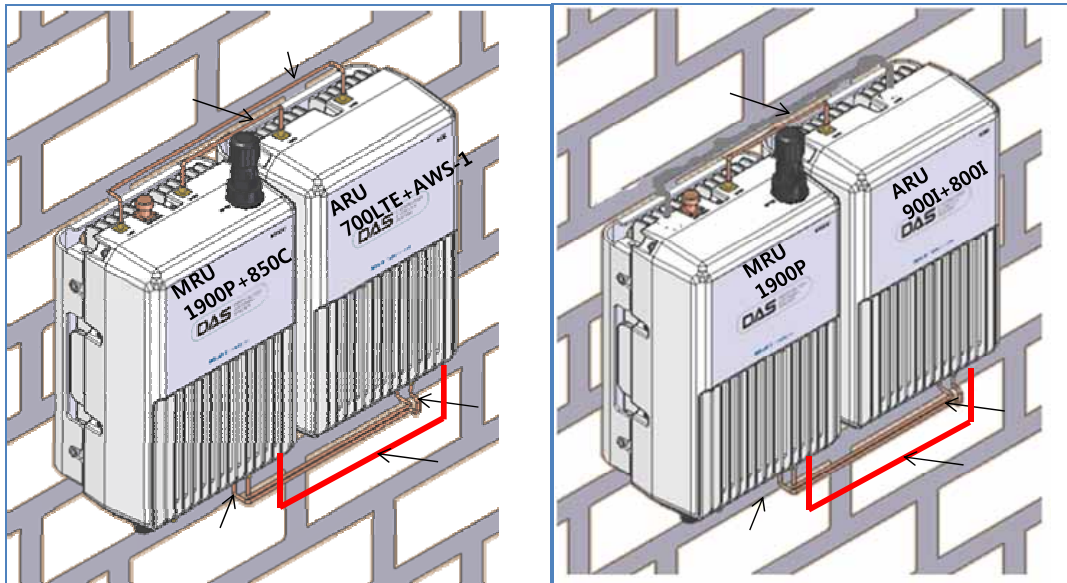

(a)MRU1900P+850C/ARU700LTE/AWS-1

(b)MRU1900P/ARU900I/800I

Figure 5.26 – Cable connection between MRU and ARU

Cable	Description	MRU Name	ARU Name	Remark
	Coaxial cable	High	High	
	Coaxial cable	Low	Low	
	Coaxial cable	TX	TX	
	Caaxial cable	RX	RX	
	Signal cable	External port	External port	

5.4 OEU Installation

OEU is used to expand the ROU in a multi building environment.

The OEU is located at a Remote Closet. As it can be equipped with up to two DOUs, you can expand a total of eight ROUs.

5.4.1 OEU chassis installation

The OEU chassis is 2RU in size and can be inserted into a 19" Standard Rack. The OEU is in a Remote Closet, providing optical ports for the ROU.

The following table shows power consumption of OEU:

No.	Unit	Description	Remark
Common Part	Chassis	Including EWDM,ERF,EPSU,ECPU, 19",2U	1EA
	Power Cable	-48Vdc Input with two lug terminal	1EA
Optional Part	DOU	Optical Module with 4 Optic Ports	Up to 2EA to be inserted

5.4.2 OEU Power Cabling

The input power of the OEU is -48VDC. You need to connect a DC cable with the Terminal Block seen at the rear of the OEU.

Terminal	Color of cable	Description	Remark
-48V	Blue color	Input range: -42 to -56Vdc	
NC	Not Connected		
GND	Black color		

Before connecting the power terminal, Verify that -48VDC is present by connecting the power supply to a DVM with “-“ terminal to positive and “+” terminal to GND of the DVM. If voltage is correct, connect the power terminal through the terminal seen below.

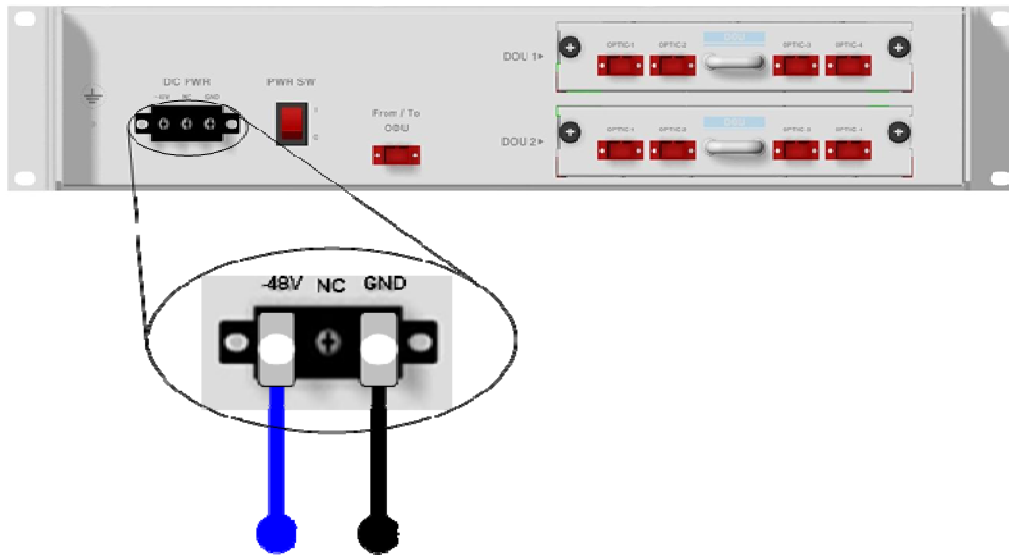

Figure 5.26 – OEU Power interface diagram



Note that OEU does not operate if the “+” terminal and the “-” terminal of the -48V power supply are reversed.

5.4.3 OEU Optic Cabling

The OEU is connected with the upper ODU. With the DOU inserted in it, the unit is connected with the ROU.

Having EWDM built in the OEU, it makes the RF-optical conversion of TX signals from ODU as well as the optical-RF conversion of RX signals. In addition, the OEU can be equipped with up to two DOUs. One DOU supports four optical ports and one optical port can be connected with the ROU. With WDM in the DOU, the unit can concurrently send/receive two different wavelengths (TX:1310nm, RX:1550nm) through one strand of fiber. The DOU has SC/APC connectors.



Figure 5.27 – Optical cable with SC/APC Type Connectors

SC/APC type connectors must be used. To prevent the optical access part from being marred with dirt, it should be covered with a cap when not installed. Connectors should be cleaned with alcohol before they are installed.

5.4.4 DOU installation with an OEU

Up to two DOUs can be inserted into an OEU chassis. The DOU module is a Plug in Play type. When you insert the DOU into the OEU, insert it into the top DOU 1 slot first. Slot numbers are silkscreened on the left.

The following figure shows installation diagram of an OEU with one DOU inserted in it.

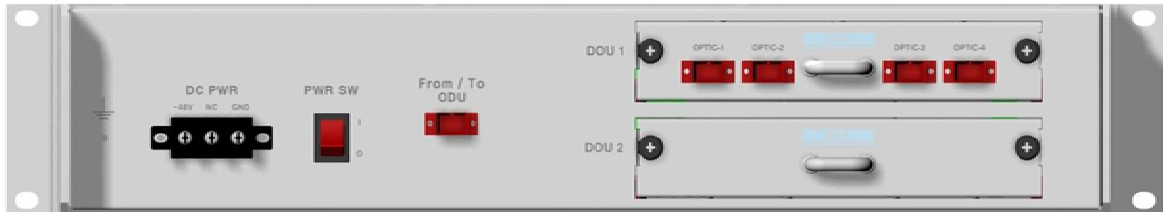

The following figure shows installation diagram of an OEU with two DOUs inserted in it.

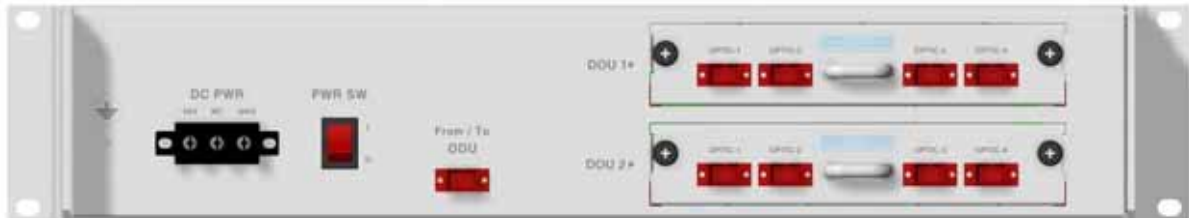

Figure 5.28 – OEU with DOUs inserted



When you insert a DOU into OEU, use the DOU 1 slot first. For unused slots, you need to install

BLANK UNIT into them.

5.4.5 OEU Power Consumption

The OEU has a -48V DC Power supply in it. The OEU can be equipped with up to two DOUs. Depending on the number of DOUs, power consumption will vary.

The following table shows power consumption of the OEU:

Part	Unit	Consumption Power	Remark
Common Part	Shelf	12W	
	EWDM		
	ERF		
	EPSU		
OEU_4	DOU 1 EA	23W	
OEU_8	DOU 2 EA	39W	

Section 6

Operation

-
- 6.1 BIU Operation**
 - 6.2 ROU Operation**
 - 6.3 OEU Operation**

This chapter describes operation of SC-DAS. It deals with procedures and operations for normal system operation after installation. It also describes operations per unit and interworking methods.

6.1 BIU Overview

6.1.1 BIU

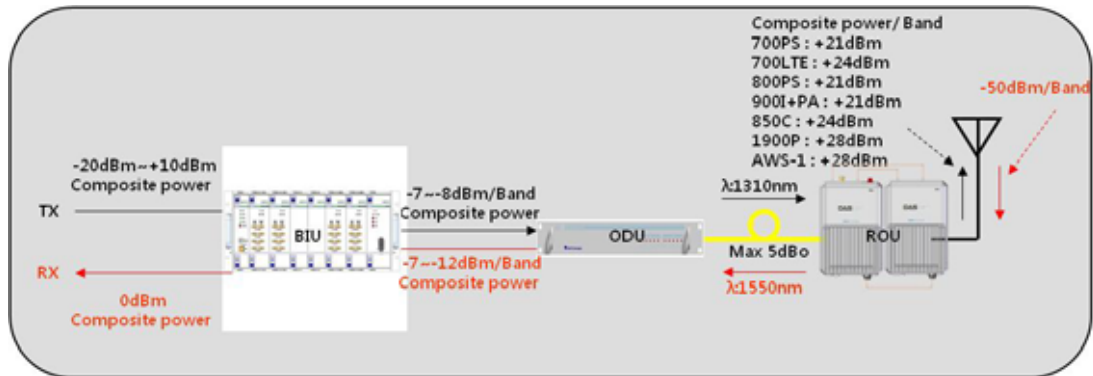

Figure 6.1 – SC-DAS Link budget for the BIU

6.1.2 BIU TX parameters

The TX level to be sent to the BIU should be in the range of -20dBm to +10dBm. If the level exceeds the range, you need to connect an attenuator to the front end of the BIU input and adjust the level in the corresponding range. If TX input is too low, maximum power cannot be achieved so you need to increase the output power of BDA or adjust attenuation amount of BTS's coupler adjust the level of the ATT.











Using a spectrum analyzer, check all bands and verify if they are in an appropriate level before making connection with input port of the BIU. Last, check to see if there are spurious signals.

Select an MDBU with the desired frequency bands and insert it into the BIU and check to see if it works normally. For the MDBU, up to two TX inputs are provided. Input level per port is -20dBm to +10dBm.

Checking the status of the system's LED Indicator

After turning on the switch of the power supply in BIU, check information on each module's LED of the system. The table below shows normal/abnormal cases depending on the status of each module's LED.

LED information

Unit	LED		Indicates
MDBU	ON		Green: MDBU is normally power-supplied.
	ALM		Green: MDBU is normal.
			Red: MDBU is abnormal; check the alarm through RS-232C.
MCPU	ON		Green: MCPU is normally power-supplied.
	TXD		Green flicker: TX signals are transmitted to communicate with ROU.
	RXD		Green flicker: RX signals are received from ROU.
	ALM		Green: BIU system is normal.
		Red: BIU system is abnormal; check the alarm through RS-232C.	
MPSU	ON		Green: BIU is connected with power and MPSU works normally.
	ALM		Green: DC output is normal.
			Red: DC output is abnormal.

MDBU Setting

Insert the MDBU into the BIU. Check if the "ON" LED Indicator at the front panel of MDBU is lit green. Make a connection with DEBUG port of the MCPU through USB Cable

Check if the ID of MDBU module is located in those SISO MDBU#1& 2, MIMO MDBU#1& 2 slots of the MDBU through the GUI. When you select the tab of a corresponding slot from the main window, you can inquire and set the status of a corresponding MDBU module.

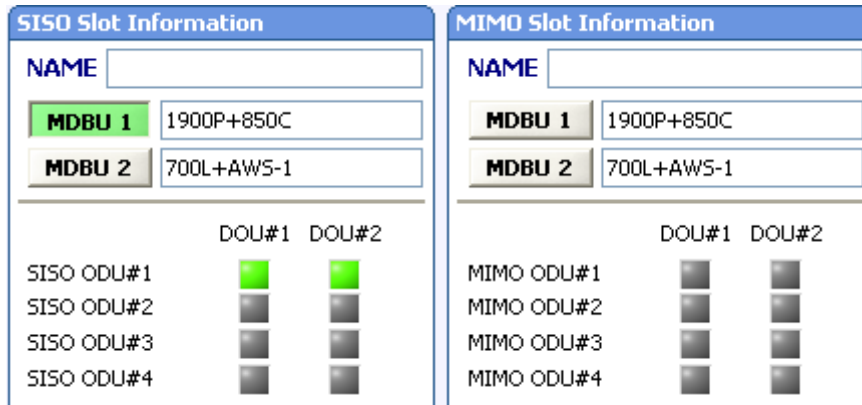

Figure 6.2 –MDBU information assigned at theBIU

Check if the MDBU is inserted into a corresponding slot of theBIU. The ID screen shows the following:

- A. MDBU ID: Show MDBU ID inserted into slot
- B. Not Insert: This status value appears when MDBU has not been set.
- C. Link Fail: This status value appears when MDBU has been set but it fails to communicate with modules.

SC-DAS is classified according to path that is as SISO and MIMO. Each path can have up to two MDBUs. These MDBUs can be different combinations as per your application

Use the ON/OFF (Activation/de-activation) function for a port you want to use and turn it ON.

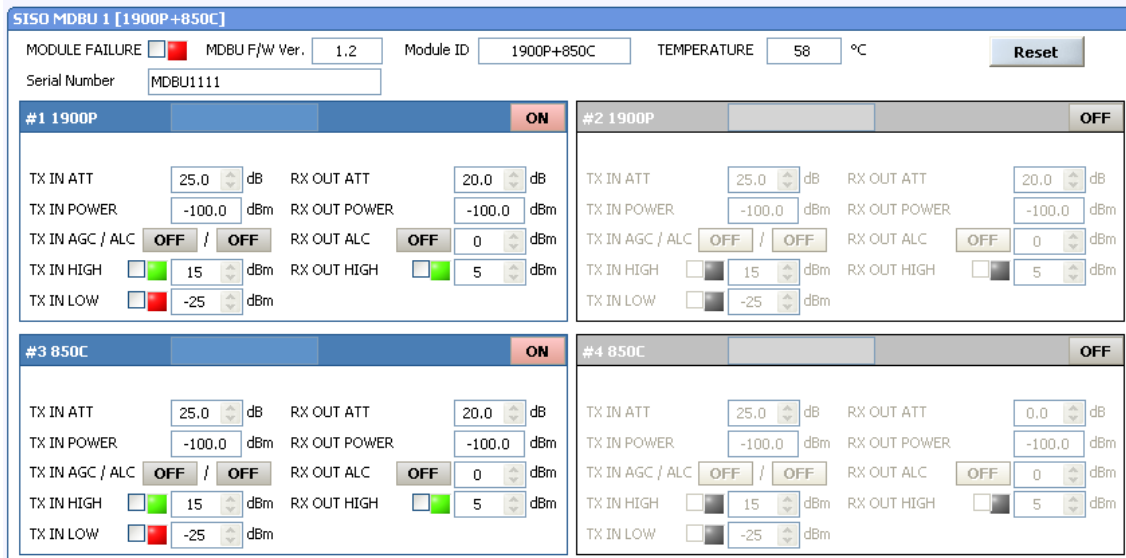

Figure 6.3 –MDBU menu information at the BIU



Make sure to turn OFF unused ports.

The table below shows output power vs number of ports

MDBU Band	Output level (Composite power)	No. of Max port (N)
700LTE	$24\text{dBm}-10*\text{LOG}(N)$	2
850Cellular	$24\text{dBm}-10*\text{LOG}(N)$	2
1900PCS	$28\text{dBm}-10*\text{LOG}(N)$	2
AWS-1	$28\text{dBm}-10*\text{LOG}(N)$	2
900l	$26\text{dBm}-10*\text{LOG}(N)$	2
800l	$26\text{dBm}-10*\text{LOG}(N)$	2
700PS	$24\text{dBm}-10*\text{LOG}(N)$	2
VHF	On the loadmap	1

UHF	$24\text{dBm} - 10 * \text{LOG}(N)$	1
-----	-------------------------------------	---

Check if the level of TX IN POWER is the same as the value measured with spectrum analyzer (Within $\pm 3\text{dB}$). Use TX IN AGC function and automatically set internal ATT depending on input level. ATT is automatically set based on -20dBm of input. The table below shows TX IN ATT depending on TX IN POWER. For manual setting, you can set ATT depending on input according to the table.

TX IN POWER	TX IN ATT	TX IN POWER	TX IN ATT	TX IN POWER	TX IN ATT
-20dBm	0dB	-9dBm	11dB	+1dBm	21dB
-19dBm	1dB	-8dBm	12dB	+2dBm	22dB
-18dBm	2dB	-7dBm	13dB	+3dBm	23dB
-17dBm	3dB	-6dBm	14dB	+4dBm	24dB
-16dBm	4dB	-5dBm	15dB	+5dBm	25dB
-15dBm	5dB	-4dBm	16dB	+6dBm	26dB
-14dBm	6dB	-3dBm	17dB	+7dBm	27dB
-13dBm	7dB	-2dBm	18dB	+8dBm	28dB
-12dBm	8dB	-1dBm	19dB	+9dBm	29dB
-11dBm	9dB	0dBm	20dB	+10dBm	30dB
-10dBm	10dB				

The MDBU cards in the BIU provide ALC (Auto Level Control) functionality for each of the inputs to limit the maximum power output per carrier input. The input level starts activating ALC at -20dBm when turning the ALC on. For correct parameter settings, first, perform the input AGC and then turn the ALC function on.

Edit the port name and set it as a desired character string (up to 12 characters). For example, the figure below shows a screen when you set "VzW" for port 1 and "AT&T" for port 2.

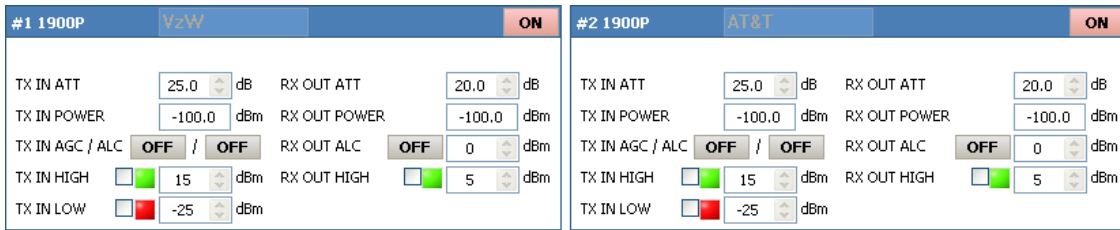

Figure 6.4 –MDBU name assignment at theBIU

This naming is reflected at the tree as follows

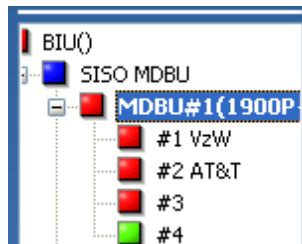

Figure 6.5 –MDBU name assignment at the tree

Use various upper/lower limits. The following table shows recommended limit settings:

Item	Recommended Limit	Remark
TX IN HIGH ALM	15dBm	Alarm
TX IN LOW ALM	-25dBm	Alarm
RX OUT ALC	0dBm	Auto Level control
RX OUT HIGH ALM	5dBm	Alarm

After you finish setting normal input levels and alarm limits, check to see if the MODULE FAILURE LED Indicator is lit green (Normal case).

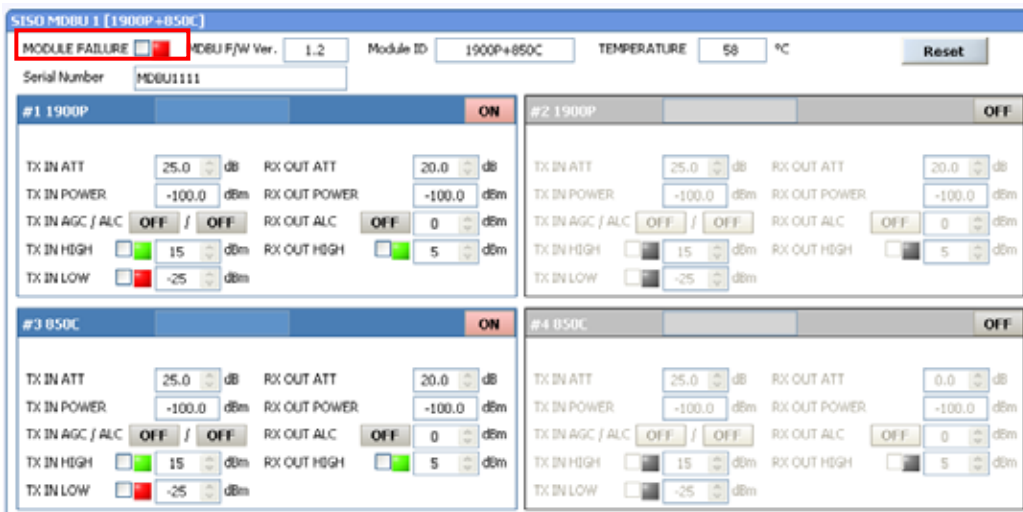

Figure 6.6 –MDBU Module Failure information at the BIU

6.1.3 BIU RX parameters

For RX operation at BIU, you need to set RX gain to prevent the BTS or BDA from being affected. There is an ATT setting window to let you adjust gain per band and port.

Total RX gain is 50dB per band. To adjust a desired gain, you need to do the following. For a desired RX gain, you can set it as 50dB-RX ATT. Use the terminal and check if TX Adjust value and Ec/Io value is appropriate.

To prevent high level signals from entering the BTS or BDA, keep ALC mode activated (ON).

6.1.4 BIU Logic Sequence Diagram

The BIU controls the overall system, working as as the head end unit of any system. The BIU connects with units such as ODU, OEU and ROU.

The tree hierarchy automatically displays the components connected to the system and communicate with lower units while collecting the status of the units.

The menu below shows topology for overall units.

Basic topology for SC-DAS Configuration of BIU-ODU-ROU

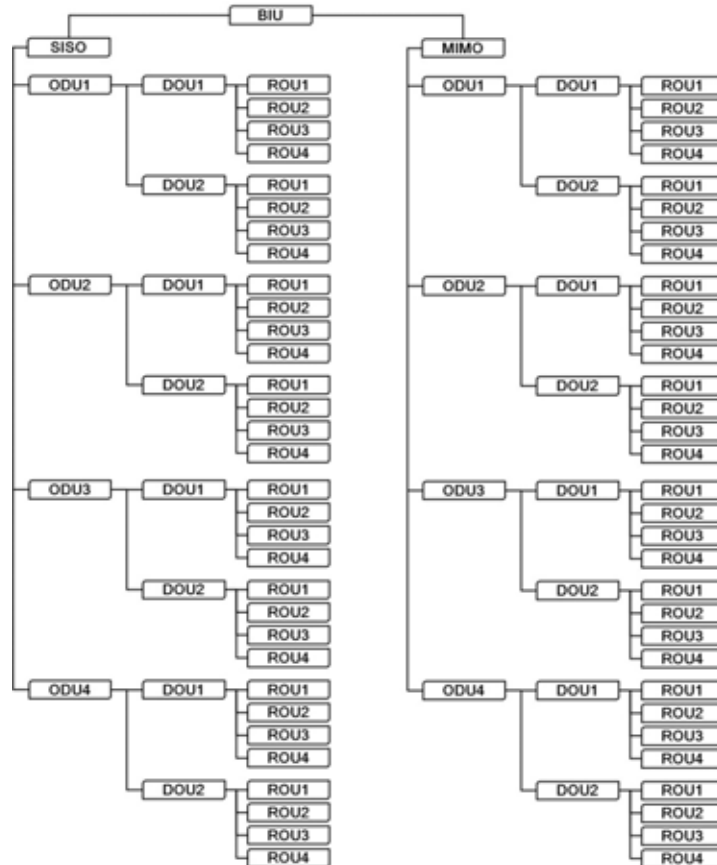

Figure 6.7 –Configuration of BIU-ODU-ROU for basic topology

The BIU has two paths : SISO and MIMO. Each path has capability to connect up to 4ODUs, one ODU can be connected up to 8ROUs. Therefore, the number of ROUs per path is 32.

Regarding the MIMO path, One BIU can connect up to 64 ROUs

Expansion topology for SC-DAS Configuration of BIU-ODU-OEU-ROU

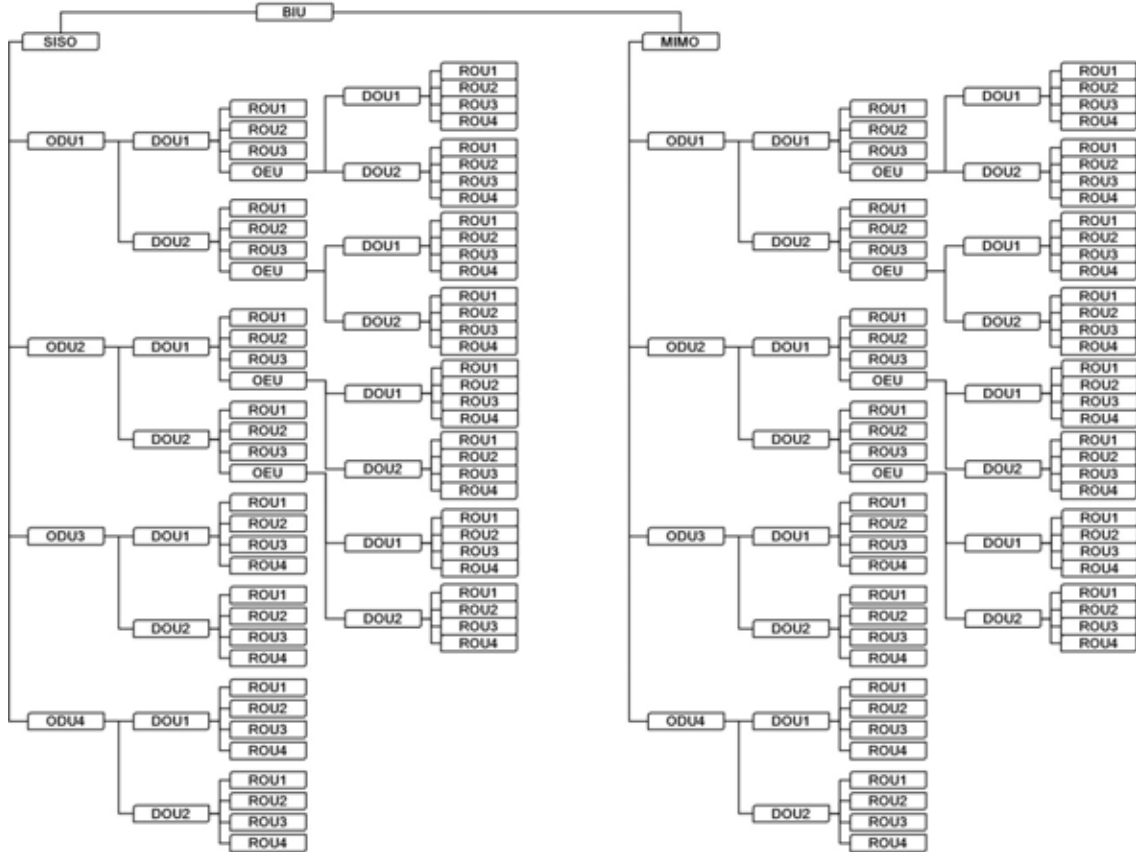

Figure 6.8 –Configuration of BIU-ODU-ROU for expansion topology

Using an OEU allows you to expand for additional ROUs as shown in the tree structures. Looking at the above tree hierarchy, an OEU can be connected with ODU1 and 2 only and regarding the optical port of a DOU, the OEU can only connect to the fourth optical port. If you try to connect the OEU ports 1 thru 3 of the DOU, the BIU won't communicate with it. This tree hierarchy is generated automatically as the ROU/OEU is connected at the ODU optical port

6.1.5 Interaction with the BIU

The BIU can be equipped with up to four ODUs per path. One ODU can have two DOUs in it. For information on insertion/deletion of the DOU in the ODU, look at the main window of the BIU as shown below

	DOU#1	DOU#2		DOU#1	DOU#2
SISO ODU#1	<input checked="" type="checkbox"/>	<input checked="" type="checkbox"/>	MIMO ODU#1	<input type="checkbox"/>	<input type="checkbox"/>
SISO ODU#2	<input type="checkbox"/>	<input type="checkbox"/>	MIMO ODU#2	<input type="checkbox"/>	<input type="checkbox"/>
SISO ODU#3	<input type="checkbox"/>	<input type="checkbox"/>	MIMO ODU#3	<input type="checkbox"/>	<input type="checkbox"/>
SISO ODU#4	<input type="checkbox"/>	<input type="checkbox"/>	MIMO ODU#4	<input type="checkbox"/>	<input type="checkbox"/>

Figure 6.9 –DOU assignment at the BIU

When you select the ODU screen from the left TREE panel, you can see the DOU 1 or DOU 2 menu activated depending on whether DOU has been inserted. Then, the optical port set at the INSTALL menu is also activated to let you check PD value of the optical port. Any unused optical port is seen de-activated in grey.

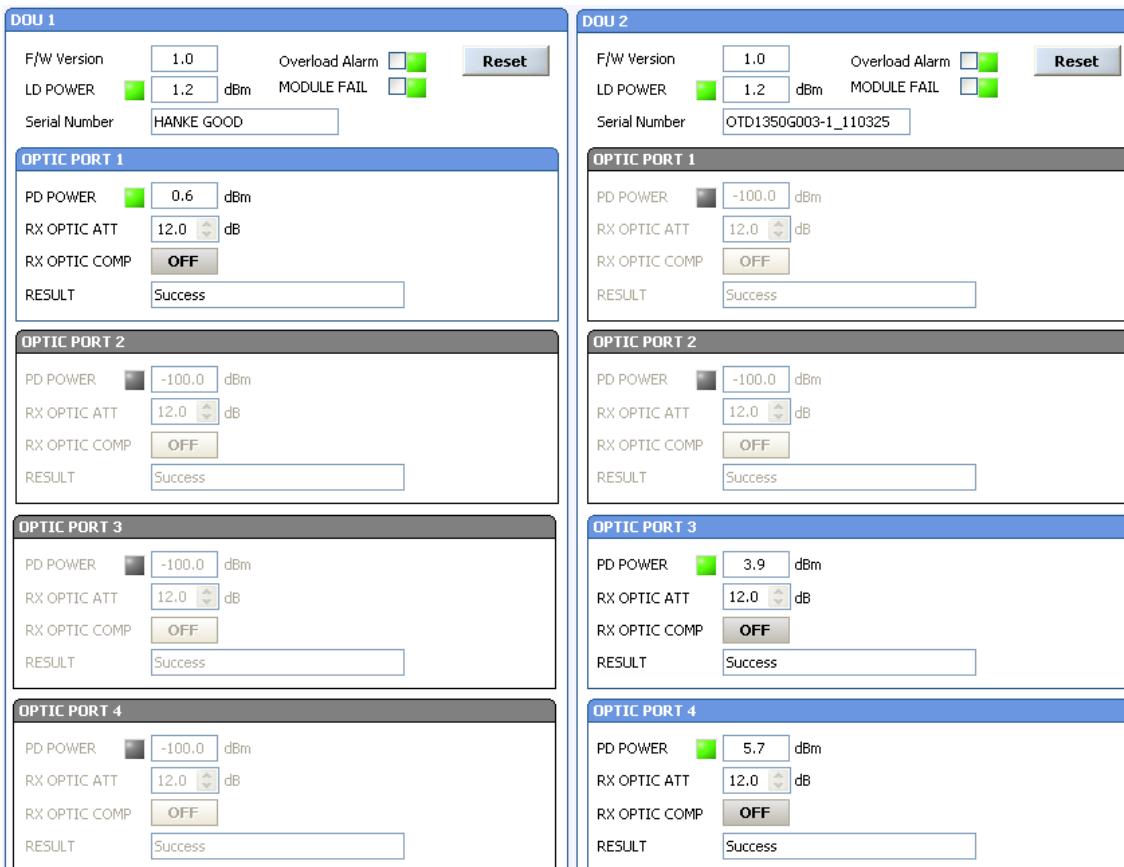

The screenshot displays two side-by-side configuration panels for DOU 1 and DOU 2. Each panel includes a 'Reset' button and status indicators for 'Overload Alarm' and 'MODULE FAIL'. Below these are fields for 'F/W Version', 'LD POWER', and 'Serial Number'. The main section contains four 'OPTIC PORT' sub-panels, each with 'PD POWER', 'RX OPTIC ATT', 'RX OPTIC COMP', and 'RESULT' fields. In the DOU 1 panel, OPTIC PORT 1 is active (blue header) with a PD POWER of 0.6 dBm, while ports 2, 3, and 4 are de-activated (grey headers) with PD POWER of -100.0 dBm. In the DOU 2 panel, OPTIC PORT 1 and 2 are de-activated (grey headers) with PD POWER of -100.0 dBm, OPTIC PORT 3 is active (blue header) with a PD POWER of 3.9 dBm, and OPTIC PORT 4 is active (blue header) with a PD POWER of 5.7 dBm. All 'RX OPTIC COMP' fields are set to 'OFF' and 'RESULT' fields show 'Success'.

Figure 6.10 –ODU Menu information

The level of DOU's Laser diode is typically $+1.5 \pm 1 \text{ dBm}$. DOUs have various alarm such as LD Power alarm, Overload Alarm and PD alarms.

The level of Laser diode received from ROU/OEU is $+7 \text{ dBm} \pm 0.5 \text{ dB}$. The level of Photo diode will be displayed with losses related to the length of optical cables and insertion loss of optical connectors.

In general, the level of optical PD POWER should be $+6 \text{ dBm}$ to $+2 \text{ dBm} \pm 1.5 \text{ dB}$.

Furthermore, the ODU has the function of automatically compensating for optical cable loss.

Initially, if BIU communicates with the lower Unit(OEU,ROU), the optical loss compensation is automatically affected.

During optical compensation, the Result window shows "Processing" and then a result value. There are three types of results as follows:

- A. Success: The optical compensation is normally completed
- B. Over Optic Loss: Generated optical loss is 5dB or more.
- C. Communication Fail: Communication with ROU is in poor condition.

The ATT for optical compensation can work based on the numerical expression of $12-2 \times (\text{LD POWER} - \text{PD POWER})$. Optical compensation can be made not only in the ODU but also in the ROU.

6.2 ROU Overview

The figure below shows the SC-DAS system link level (BIU-ODU-ROU). This section describes ROU-related information. The ROU receives various signals through optical modules. These signals are filtered only for corresponding signal band from the MFR/ARF module and amplified with a High Power Amplifier. Then, the multiplexer combines the signals with others and sends them to the antenna port.

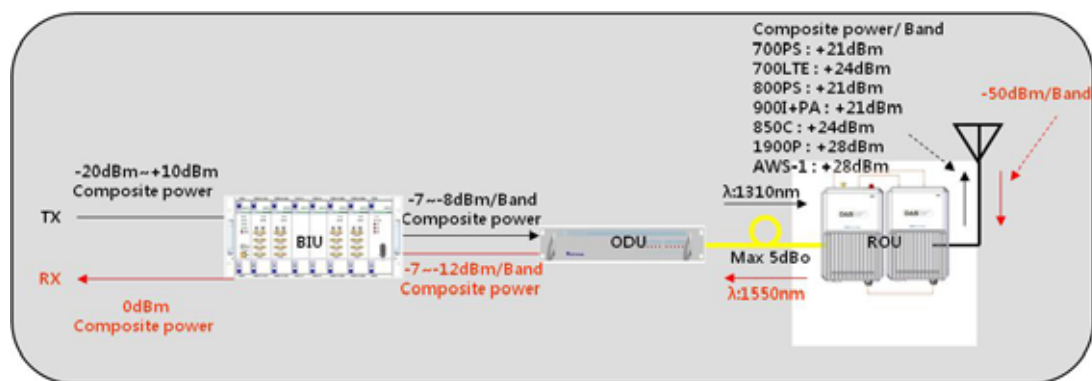

Figure 6.11 –SC-DAS Link budget for ROU

6.2.1 ROU Operation

The ROU is a one-body enclosure type and is located at a remote closet in the building. It can be installed on a wall or into a rack.









Basically, only one antenna port is provided. To install multiple antennas, you need dividers and/or couplers. The ROU can work with a DC Feeder and an Optic Cable Feeder. To power the ROU, a power supply of either AC-DC or DC-DC can be selected depending on the application.

For upper level, the ROU can be connected with the ODU and OEU. It has an AGC function for 5dB_o of optical cable loss.

The following shows operational procedures after installation of the ROU.

Checking the status of ROU's LED Indicator

When power cable is plugged into an outlet, power is provided for the ROU. Check information on each module's LED of the system. The table below shows normal/abnormal cases depending on the status of each module's LED.

LED		Description
ON		Power is not supplied
		Power is supplied.
ALM		Normal Operation
		Abnormal Operation
OPT		R-OPT is normal operation
		R-OPT is abnormal Operation
TXD		Flashing when data send to upper unit
RXD		Flashing when data receive from upper unit

Checking Communication LED of ROU

Check if TXD and RXD LEDs in the MRU make communication. Receiving FSK signals from the BIU,

the ROU sends requested status value to the BIU. During reception, RXD LED blinks. During transmission, TXD LED blinks. At this time, you need to see if whether to use a corresponding ROU is checked on

When the ARU is connected with the MRU, check if TXD and RXD LEDs at ARU blink. At this time, check whether external cable is connected to the MRU and ARU

ROU Optic Comp Operation

The ROU has the function of automatically compensating for optical loss. It can do the work for up to 5dBo of optical loss. Set “TX OPTIC COMP” of the MRU to "ON." Optical compensation of ROU can not be made without communication to the ODU or OEU. For 1dBo of optical loss, basic TX OPTIC ATT is 1dB; for 5dBo of optical loss, TX OPTIC ATT is 4dB. OPTIC COMP works only one time before it stays dormant.

The figure below shows a screen for OPTIC Information in ROU GUI.

LD POWER references the output level of ROU Laser Diode which is sent to a upper unit by the ROU. PD POWER references the input level of Photo Diode to be received from a upper unit.

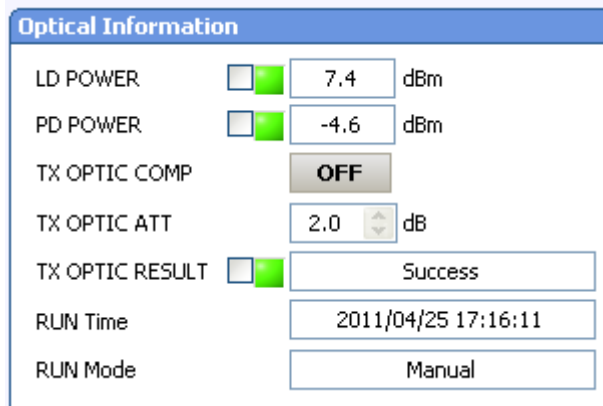

Optical Information	
LD POWER	<input checked="" type="checkbox"/> 7.4 dBm
PD POWER	<input checked="" type="checkbox"/> -4.6 dBm
TX OPTIC COMP	OFF
TX OPTIC ATT	2.0 dB
TX OPTIC RESULT	<input checked="" type="checkbox"/> Success
RUN Time	2011/04/25 17:16:11
RUN Mode	Manual

Figure 6.12 –Optical information at the ROU

Initially, When the ROU communicates with the upper device(ODU/OEU), optical loss compensation is done automatically. During optical loss compensation, the result window shows "Processing" and then a result value is displayed. There are three types of results as follows:

1. Success: The optical compensation is normally completed.
2. Over Optic Loss: Generated optical loss is 5dBo or more.
3. Communication Fail: Communication with ROU is in poor condition.

Continue if TX optic result is successful. If the results are “over optic Loss”, clean optical connector face using clear cloth, and then operate TX OPTIC COMP again.

Also, you can perform optical loss compensation manually. Here, RUN Mode displays two types as shown below

1. Auto : CPU of MRU is performed automatically when is commnicated with upper device
2. Manual : when user performs manually. This result will display



If ROU does not make optical compensation, there will be errors in the system link budget . It can cause lower output levels or make Spurious Emissions detrimental to the system.

ROU Setting

The MRU can be interfaced with two RUs. One is an ARU which is provided with an extra carrier band. The other is a VHF+UHF RU which is provided with public safety service required in the building code.

Through the GUI at the MRU, it queries the status and control of the MRU, the ARU and the VHF+UHF RU

MRU	1900P+850C	Support ARU	700LTE+AWS-1
ARU	700LTE+AWS-1	Supporting ARU	Correct ARU
VHF+UHF	E-VHF+UHF	Repeater TYPE	INDOOR

Figure 6.13 –ROU information assignment

By clicking the main menu which is MRU,ARU and VHF+UHF, you can query and control these units

Set HPA of a corresponding RDU as “ON.” Use TX OUTPUT AGS function and set it as a desired output level.

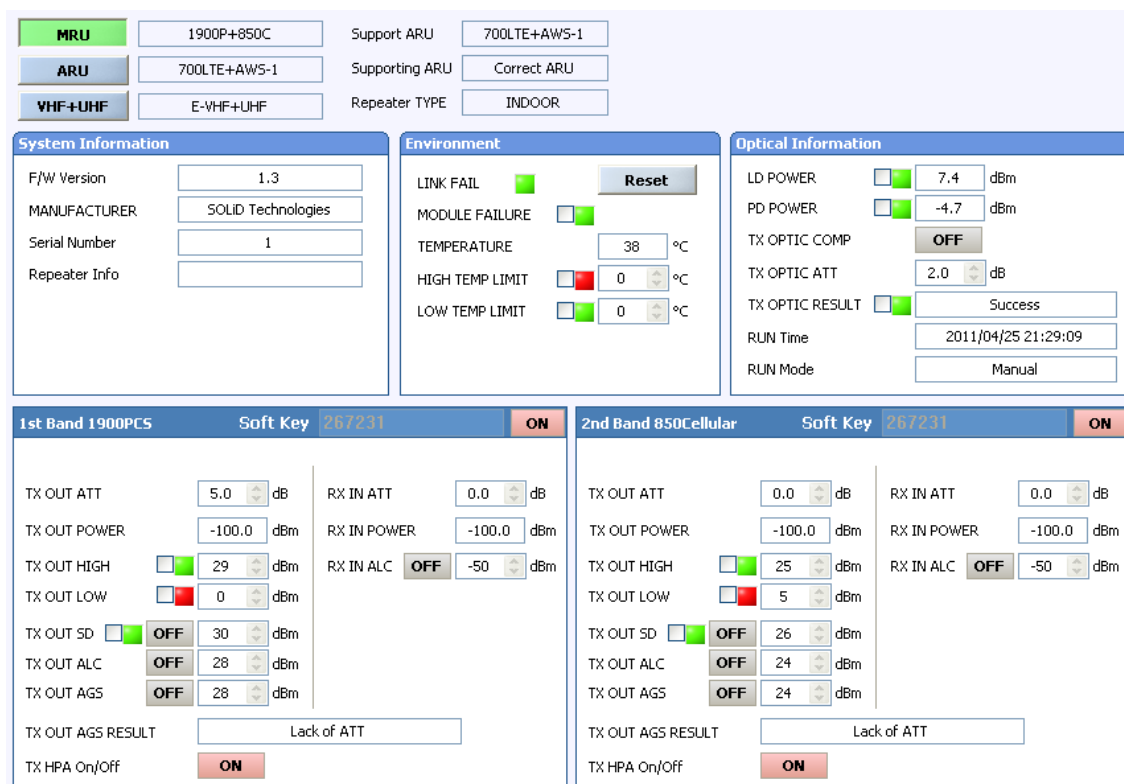

The screenshot displays the ROU configuration interface. At the top, it shows the same assignment table as Figure 6.13. Below this, there are three main sections: System Information, Environment, and Optical Information. The System Information section includes fields for F/W Version (1.3), MANUFACTURER (SOLID Technologies), Serial Number (1), and Repeater Info. The Environment section shows status indicators for LINK FAIL, MODULE FAILURE, and temperature (38 °C), along with HIGH and LOW TEMP LIMIT settings (both 0 °C). The Optical Information section displays LD POWER (7.4 dBm), PD POWER (-4.7 dBm), TX OPTIC COMP (OFF), TX OPTIC ATT (2.0 dB), TX OPTIC RESULT (Success), RUN Time (2011/04/25 21:29:09), and RUN Mode (Manual). The bottom half of the screen is divided into two panels for '1st Band 1900PCS' and '2nd Band 850Cellular'. Each panel shows TX and RX parameters such as TX OUT ATT, TX OUT POWER, TX OUT HIGH, TX OUT LOW, TX OUT SD, TX OUT ALC, TX OUT AGS, and TX HPA On/Off status (ON).

Figure 6.14 –ROU Menu information

The table below shows maximally allowable Composite Powerlevels that can be set per band:

RDU Band	Power that can be maximally set	Setting range	Remark
700LTE	24dBm	0 ~ 24dBm	ARU700LTE+AWS-1
850Cellular	24dBm	0 ~ 24dBm	MRU 1900PCS+850C
1900PCS	28dBm	0 ~ 28dBm	MRU 1900PCS+850C
	31dBm	0 ~ 28dBm	MRU 1900PCS
AWS-1	28dBm	0 ~ 28dBm	ARU700LTE+AWS-1

900l	26dBm	0 ~ 26dBm	ARU900l+800l
800l	26dBm	0 ~ 26dBm	ARU900l+800l

AGS function enables you to adjust output power as you like. While the AGS function is being executed, the Result window shows "Processing" and then a result value is displayed. There are three types of results as follows:

- A. Success: The AGS function is normally completed.
- B. Not Operate OPTIC Comp: Optic Comp is not executed.
- C. Lack of ATT: There is no attenuation available.

Set the upper/lower limits. The following table shows recommended limit settings:

Item	Recommended Limit	Remark
TX OUTPUT HIGH ALM	Max Composite Power+1dB	Alarm
TX OUTPUT LOW ALM	0dBm	Alarm
TX OUTPUT ALC	Max Composite Power	Auto Level control
TX OUTPUT SD	Max Composite Power+2dB	Shutdown
RX ALC	-45dBm	

If TX OUTPUT HIGH ALM is higher than a setting value, alarms will be generated.

If TX OUTPUT LOW ALM is lower than a setting value, alarms will be generated. TX OUTPUT HIGH ALM/LOW ALM tends to work only as warning.

When you activate ("ON") TX OUTPUT ALC, outputs will be restricted depending on a setting output value.

When you activate ("ON") TX OUTPUT SD, output will be turned OFF once output power level reaches the same as SD setting value. Upon SD operation, check output level after 10 minutes and then check the status again.

When you activate ("ON") RX ALC, inputs will be restricted depending on a setting value.

As described above, when normal output level and alarm limit values are set, you need to check if the value of MODULE FAILURE LED Indicator is green.

For unused bands, you need to use band select-ON/-OFF function to turn them off.

The ROU has softkey function, when softkey is identified with serial number, the band can be activated.

If the softkey do not identify with the serial number, you can not use that band. The softkey has a unique value according to serial number. To use two bands simulatanously, you should enter softkey value.



Figure 6.15 –ROU Softkey information

, The ROU has unique serial number and also a unique softkey.

6.3 OEU Operation

The figure below shows the system link level of SC-DAS (BIU-ODU-OEU-ROU). This section describes OEU-related information. The OEU receives various signals through optical modules. The optical signals are converted to RF signals and the RF signal are amplified to moderate signal levels. To transmit to ROU, the signal is converted to an optical signal

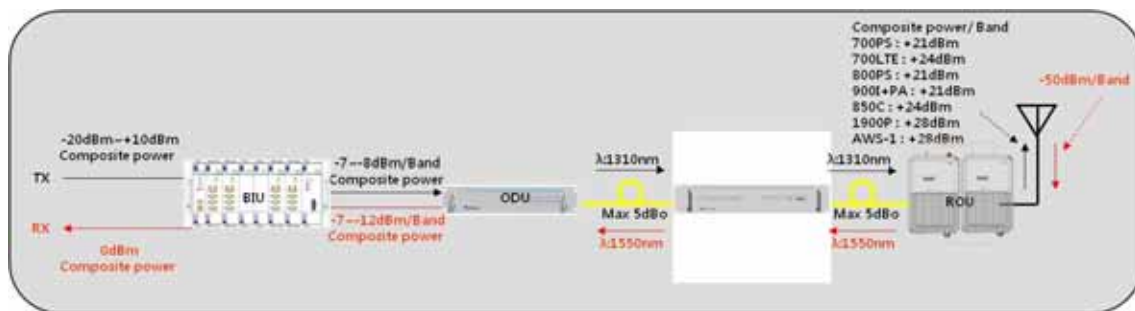

Figure 6.16 –SC-DAS Link Budget for OEU

6.3.1 OEU Operation

The OEU comes as a rack mount chassis and is located at a remote closet in a building.













The OEUs main function is to act as a hub for expansion to other buildings, It only requires one strand of fiber to expand to 8 ROUs.(OEU supports up to 2 DOUs and the DOU supports up to 4 optical ports that connect ROUs).

The ROU can work with a DC Feeder and an Optic Cable Feeder. of the OEU requires a DC-DC power supply.

In the other direction, the OEU can be connected with a ODU. It has optical loss compensation function for 5dBm of optical cable loss. The following shows operational procedures after installation of the OEU.

Checking the status of OEU's LED Indicator

After turning on the switch of the power supply in the OEU, check information on each module's LED of the system. The table below shows normal/abnormal cases depending on the status of each module's LED.

Unit	LED		Indicates	
EWDM	LD		Green : Laser Diode normal status	
			Red :Laser Diode abnormal status	
	PD		Green : Photo Diode normal status	
			Red : Photo Diode abnormal status, input optic power low alarm	
DOU1,2	LD		Green : Laser Diode normal status	
			Red :Laser Diode abnormal status	
	PD1		Green : Photo Diode(PD) of optic port1 is normal	
			Red : PD of optic port1 is abnormal or input optic power low	
	PD2		Green : Photo Diode(PD) of optic port2 is normal	
			Red : PD of optic port2 is abnormal or input optic power low	
	PD3		Green : Photo Diode(PD) of optic port3 is normal	
			Red : PD of optic port3 is abnormal or input optic power low	
	PD4		Green : Photo Diode(PD) of optic port4 is normal	
			Red : PD of optic port4 is abnormal or input optic power low	
	System	ON		Green : Power on
		TXD1		Green flicker : ECPU send NMS Tx data to BIU
RXD1			Green flicker : ECPU receive NMS Rx data from BIU	
TXD2			Green flicker : ECPU send NMS Tx data to ROU	
RXD2			Green flicker : ECPU receive NMS Rx data from ROU	
ALM			Green : OEU system normal (no alarm)	

		●	Red :OEU system abnormal (alarm)
--	--	------------------------------------	----------------------------------

Checking Communication LED of OEU

Step 1 : checking whether there is communication with the BIU(ODU)

Check if TXD1 and RXD2 LEDs in OEU front LED make communication. Receiving FSK signals from BIU, the OEU sends requested status value to BIU. During reception, RXD1 LED flicks. During transmission TXD1 LED flicks.

Step 2 : Checking whether there is communication with the ROU

OEU configured as a Hub. OEU has two optical ports. One is connected to upper ODU and the others is connected to ROU. Communication with ODU was checked at above step 1

Step 3 is checking whether the OEU communicates with the ROU. The OEU request status to the ROU and then TXD2 blinks If responses data is received from ROU, RXD2 LED blinks

OEU Optic Comp Operation

The OEU has the function of automatically compensating for optical calbe loss. It can do the work for up to 5dBo of optical loss. Set “TX OPTIC COMP” of OEU’s optic as "ON." Optical compensation of the OEU can not be made without communication with the ODU. For 1dBo of optical loss, TX OPTIC ATT is 1dB; for 5dBo of optical loss, TX OPTIC ATT is 4dB. OPTIC COMP works only one time before it stays dormant.

The figure below shows a screen for OPTIC Information in the OEU GUI.

LD POWER references the output level of OEU Laser Diode, which is sent to a upper unit by the OEU.

PD POWER references the input level of Photo Diode to be received from a upper unit.

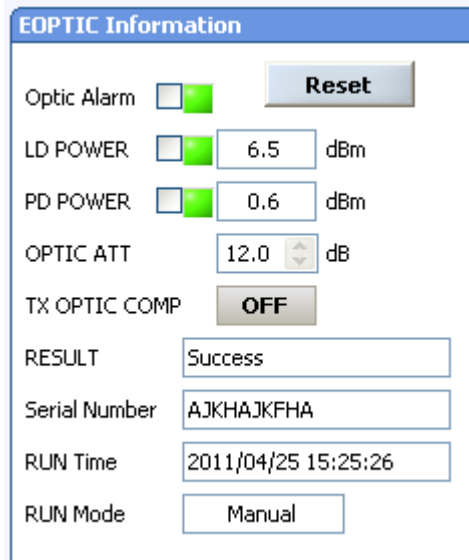

Figure 6.17 –OEU Optical information

Normal LD power level is typically $+7\text{dBm} \pm 1\text{dBm}$, PD power is range of $+1\text{dBm}$ to -5dBm . The results value is same to the ROU's optical loss compensation(see the ROU more detail)

Like the ROU, the OEU performs optical loss compensation automatically when the OEU communicates with upper ODU first.

During optical compensation, the Result window shows "Processing" and then a result value is displayed. There are three types of results as follows:

1. Success: The optical compensation is normally made.
2. Over Optic Loss: Generated optical loss is 5dBo or more.
3. Communication Fail: Communication with ROU is in poor condition.

The OEU can be inserted with two DOUs. The DOU's behavior is exactly same to the ODU(See the ODU for more detail)



If OEU does not make optical compensation, there will be errors in the system link budget . It can cause low output levels or make Spurious Emissions detrimental to the system.

Section 7

Additive functions

-
- 7.1 Shutdown function**
 - 7.2 Total power limit function**
 - 7.3 Automatic Output power setting function**
 - 7.4 Input power AGC function**
 - 7.5 Input power limit function**
 - 7.6 Optic loss compensation**

This chapter describes additive functions of SC-DAS

7.1 Shutdown function (TX output shutdown)

The DAS has an automatic shutdown function to protect the DAS itself and the wireless network when the normal operational conditions cannot be maintained

Shut down is triggered automatically when the composite power downlink output is above the values defined as average for the device for a period not to exceed 5 seconds. Critical levels are set through the GUI

After automatic shutdown, the system may automatically turn-on in order to assess whether the temporary condition has changed. If the condition is still detected, the DAS shall shutdown again. This action will be repeated 5 times

After The 5th time, if the condition is still detected, the DAS will be shutdown permanently. The following diagram shows the shutdown logic

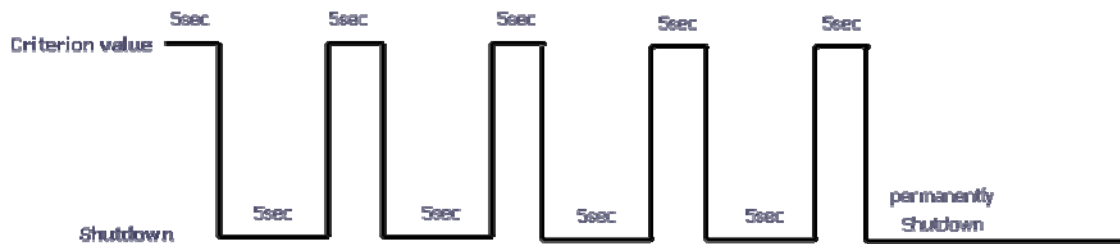

Figure 7.1 –Shutdown logic diagram

After the retry logic exhausts itself, the DAS will shutdown permanently and illuminate the fault via visual fault indicator

Permanent shutdowns of the DAS will also be reported to the NOC through the NMS

7.2 Total Power Limit function (TX Output ALC)

In order to protect the HPA and not to radiate spurious emissions, output power is limited to a defined value which is set by the operator in advance. To execute this function, operator should turn-on the ALC function and set limit level through the GUI. If the output power exceeds the defined value, the output attenuator is adjusted to return it within defined value. The output attenuator’s adjustment range is 25dB max. If output power decreases, attenuation is decreased using the AGC function to return to the initial attenuation level.

7.3 Automatic Output power setting function (TX Output AGC)

To provide convenience of setting output power at initial setup automatically, set output to desired level and turn-on the AGC function. The output power is automatically set to defined level.

After AGC logic is complete, logic operation results will show on the result window of the GUI. There are three types of results as follows

1. Success: The AGS function is normally completed.
2. Not Operate OPTIC Comp: Optic Comp is not executed.
3. Lack of ATT: There is no attenuation available.

If normal logic can't be executed, changed ATT will return to initial ATT

Through the output AGC function, it can be verified whether optic compensation is executed or not.

7.4 Input power AGC function (TX Input AGC)

This function is to help the operator with initial setting during installation.

Without a spectrum analyzer, we can see the input power value through power display window of the GUI. Use the TX IN AGC function and automatically set the internal ATT depending on the input level. The ATT is automatically set based on -20dBm input . The table below shows TX IN ATT depending on TX IN POWER. For manual setting, you can set ATT depending on input according to the table.

TX IN POWER	TX IN ATT	TX IN POWER	TX IN ATT	TX IN POWER	TX IN ATT
-20dBm	0dB	-9dBm	11dB	+1dBm	21dB
-19dBm	1dB	-8dBm	12dB	+2dBm	22dB
-18dBm	2dB	-7dBm	13dB	+3dBm	23dB
-17dBm	3dB	-6dBm	14dB	+4dBm	24dB
-16dBm	4dB	-5dBm	15dB	+5dBm	25dB
-15dBm	5dB	-4dBm	16dB	+6dBm	26dB
-14dBm	6dB	-3dBm	17dB	+7dBm	27dB
-13dBm	7dB	-2dBm	18dB	+8dBm	28dB

-12dBm	8dB	-1dBm	19dB	+9dBm	29dB
-11dBm	9dB	0dBm	20dB	+10dBm	30dB
-10dBm	10dB				

7.5 Input power limit function (TX Input ALC)

The DAS has a TX input ALC function at the BIU to limit level when input power is increased above level by operated input AGC function

Normally, there are no more than two input ports in the MDBU of the BIU

For example, the 850 cellular band has two input ports to support both VzW and AT&T

These two input powers may be different from each other. The DAS has an input attenuator in first stage of the MDBU. Through input AGC function, the input ATT is adjusted according to the input power. If input power increases, the input ATT is adjusted again to limit increased input power and if the input power decreases, the input ATT will return to the initial ATT setting.

7.6 Optical loss compensation

The DAS has the function of automatically compensating for optical loss. It can do the work for up to 5dB of optical loss. Set "TX OPTIC COMP" of ROU as "ON." Optical compensation of ROU can not be made without communication to the ODU or OEU. For 1dB of optical loss, basic TX OPTIC ATT is 1dB; for 5dB of optical loss, TX OPTIC ATT is 4dB. OPTIC COMP works only one time before it stays dormant.

The figure below shows a screen for OPTIC Information in the ROU GUI.

LD POWER references the output level of ROU Laser Diode, which is sent to a upper unit by ROU. PD POWER references the input level of Photo Diode to be received from a upper unit.

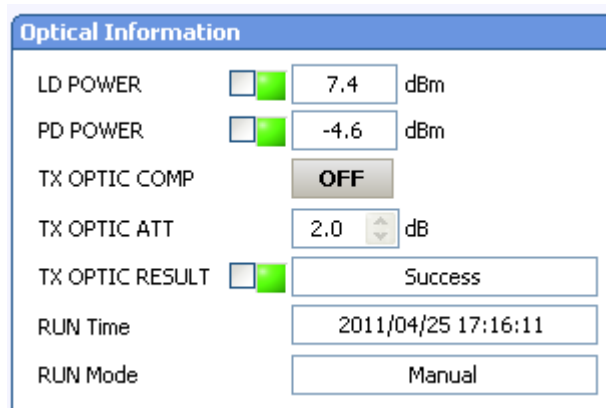

Figure 7.2 –Optical loss information

During optical compensation, the Result window shows "Processing" and then a result value is displayed. There are three types of results as follows:

1. Success: The optical compensation is normally completed
2. Over Optic Loss: Generated optical loss exceed 5dBo or more.
3. Communication Fail: Communication with ROU is under poor condition.