SMDR-NH124

Installation and Operation Manual



Document Reference:

Version:	V5.0
Document Status:	Release 1
Issue Date:	Feb. 21, 2011
Author:	Kyung Eun Han
Department:	R&D Division Team 3
Authorizing Manager:	Youngshin Yeo

REVISION HISTORY

Version	Issue Date	No. of Pages	Initials	Details of Revision Changes
V 1.0	Jan. 02, 2009		Original	
V 2.0	Oct. 23, 2009			Add RDU(VHF+UHF)
V 3.0	Feb. 04, 2010			Add ADD ON V/UHF ROU
V 4.0	Nov. 24, 2010			Add RDU E-VHF+UHF
V 5.0	Feb. 21, 2011			LTE FULL BAND

Technical Support

SOLiD serial numbers must be available to authorize technical support and/or to establish a return authorization for defective units. The serial numbers are located on the back of the unit, as well as on the box in which they were delivered. Additional support information may be obtained by accessing the SOLiD Tehcnology, Inc. website at www.st.co.kr or send email at sjkim@st.co.kr

This manual is produced by Global Business Division Business Team 1. Printed in Korea.

Contents

Section1	<i>Safety & Certification Notice</i>	10
Section2	<i>System Overview</i>	12
2.1	General overview	13
2.2	System overview	14
Section3	<i>System Specifications</i>	16
3.1	System specifications	17
3.1.1	Physical Specifications	17
3.1.2	Optic wavelength and Laser power	18
3.1.3	Environmental specifications	18
3.1.4	Operating Frequencies range	18
3.1.5	Specifications Per band	19
Section4	<i>System Configuration and Functions</i>	24
4.1	BIU (BTS Interface Unit)	25
4.1.1	<i>Specifications of BIU</i>	25
4.1.2	<i>Block diagram of BIU</i>	26
4.1.3	<i>BIU parts</i>	26
4.1.4	<i>Function by unit</i>	27
4.1.5	<i>Front/rear panels of BIU</i>	32
4.2	ODU (Optic distribution Unit)	34
4.2.1	<i>Specifications of ODU</i>	34
4.2.2	<i>Block Diagram of ODU</i>	35
4.2.3	<i>ODU parts</i>	35
4.2.4	<i>Function by unit</i>	36
4.2.5	<i>Front/rear panels of ODU</i>	37
4.2.6	<i>Interface with BIU</i>	38
4.3	OEU (Optic Expansion Unit)	39

4.3.1	<i>Specifications of OEU</i>	40
4.3.2	<i>Block Diagram of OEU</i>	40
4.3.3	<i>OEU parts</i>	40
4.3.4	<i>Function by unit</i>	41
4.3.5	<i>Front/rear panels of OEU</i>	45
4.4	<i>ROU (Remote Optic Unit)</i>	46
4.4.1	<i>Specifications of ROU</i>	46
4.4.2	<i>Block Diagram of ROU</i>	47
4.4.3	<i>ROU parts</i>	47
4.4.4	<i>Function by unit</i>	49
4.4.5	<i>Bottom of ROU</i>	54
4.5	<i>Add on V/UHF ROU</i>	55
4.5.1	<i>Specifications of AOR</i>	56
4.5.2	<i>Block Diagram of AOR</i>	56
4.5.3	<i>AOR parts</i>	57
4.5.4	<i>Function by unit</i>	58
4.5.5	<i>Rear of AOR</i>	61
Section5	<i>System Installation & Operation</i>	63
5.1	<i>BIU Installation</i>	64
5.1.1	<i>BIU Shelf Installation</i>	64
5.1.2	<i>BIU Power Cabling</i>	65
5.1.3	<i>RF Interface at BIU</i>	66
5.1.4	<i>MDBU insertion</i>	71
5.1.5	<i>ODU Interface</i>	72
5.1.6	<i>Consumption Power of BIU</i>	74
5.2	<i>ODU Installation</i>	74
5.2.1	<i>ODU Shelf Installation</i>	75
5.2.2	<i>ODU Power Cabling</i>	75

5.2.3	ODU Optic Cabling.....	75
5.2.4	Insert DOU to ODU.....	75
5.2.5	Consumption Power of ODU.....	76
5.3	ROU Installation	76
5.3.1	ROU Enclosure installation.....	76
5.3.2	ROU Power Cabling	80
5.3.3	Optical Cabling	81
5.3.4	GND Terminal Connection	82
5.3.5	Coaxial cable and Antenna Connection	82
5.3.6	Insertion of RDU.....	82
5.3.7	Consumption of RDU.....	93
5.4	OEU Installation	94
5.4.1	OEU Shelf installation	94
5.4.2	OEU Power Cabling	94
5.4.3	OEU Optic Cabling.....	95
5.4.4	Insert DOU to OEU.....	96
5.4.5	Consumption Power of OEU.....	97
5.5	ADD ON ROU Installation.....	97
5.5.1	AOR Enclosure installation.....	97
5.5.2	AOR Power Cabling.....	101
5.5.3	GND Terminal Connection	102
5.5.4	Coaxial cable and Antenna Connection	103
5.5.5	Consumption Power of AOR.....	103
5.5.6	Interface with existing ROU	103
Section 6	Operation.....	106
6.1	BIU Operation.....	107
6.1.1	BIU.....	107
6.1.2	TX Operation at BIU.....	107
6.1.3	RX Operation at BIU.....	111
6.1.4	Setting whether to use ROU/OEU at BIU	111
6.1.5	ODU Operation at BIU.....	113
6.2	ROU Operation	115
6.2.1	ROU Operation.....	115
6.3	OEU Operation	120
6.3.1	OEU Operation	121

Section7	<i>Additive functions</i>	125
7.1	Shutdown function (TX output shutdown).....	126
7.2	Total Power Limit function (TX Output ALC)	126
7.3	Output power automatic setting function (TX Output AGC)	126
7.4	Input power AGC function (TX Input AGC)	127
7.5	Input power limit function (TX Input ALC)	128
7.6	Optic loss compensation	128

Contents of Figure

Figure 2.1 – Basic system topology	14
Figure 2.2 – Expansion system topology	15
Figure 4.1 – BIU outer view	25
Figure 4.2 – BIU mounting diagram	26
Figure 4.3 – MDBU Outer Look	30
Figure 4.4 – MDBU Outer Look	30
Figure 4.5 – MCPU Outer Look	31
Figure 4.6 – MPSU Outer Look	32
Figure 4.7 – BIU front panel Outer Look	32
Figure 4.8 – Rear panel Outer Look	33
Figure 4.9 – ODU Outer Look	34
Figure 4.10 – ODU Inner Look	35
Figure 4.11 – MDBU Outer Look	36
Figure 4.12 – 2Way Divider Outer Look	37
Figure 4.13 – ODU front panel Outer Look	37
Figure 4.14 – ODU Rear panel Outer Look	37
Figure 4.15 – Interface between BIU and ODU	38
Figure 4.16 – OEU Outer Look	39
Figure 4.17 – OEU Inner Look	40
Figure 4.18 – MDBU Outer Look	41
Figure 4.19 – EWDM Outer Look	42
Figure 4.20 – ECPU Outer Look	43
Figure 4.21 – ERFM Outer Look	43

Figure 4.22 – ERFM Outer Look	44
Figure 4.23 – OEU front panel Outer Look.....	45
Figure 4.24 – Rear panel Outer Look.....	45
Figure 4.25 – ROU Outer Look	46
Figure 4.26 – ROU Inner Look	47
Figure 4.27 – RDU Outer Look.....	51
Figure 4.28 – R OPTIC Outer Look	52
Figure 4.29 – RCPU Outer Look	52
Figure 4.30 – Multiplexer Outer Look	53
Figure 4.31 – ROU Bottom Look.....	54
Figure 4.32 – AOR Outer Looks	55
Figure 4.33 – AOR Inner Look.....	57
Figure 4.34 – RDU Outer Look.....	60
Figure 4.35 – AOR Rear Look	61
Figure 5.1 – RACK Installation	64
Figure 5.2 – 800PS BDA Interface using Circulator	70
Figure 5.3 – 800PS BDA Interface using Duplexer	70
Figure 5.4 – Optical cable of SC/ACP Type	75
Figure 5.5 – How to install ROU	77
Figure 5.6 – Dimension used to install ROU on the WALL.....	77
Figure 5.7 – Optical cable of SC/ACP Type	96
Figure 5.8 – How to install AOR	97
Figure 5.9 – Dimension used to install AOR on the WALL	98
Figure 5.10 – Installation flow diagram when AOR installs on wall	99

Figure 5.10 – Installation flow diagram when AOR installs in the rack 100

Figure 5.10 – AOR which is installed above of ROU 104

Section 1

Safety & Certification Notice

“Only qualified personnel are allowed to handle this unit. Read and obey all the warning labels attached in this user manual”

Any personnel involved in installation, operation or service of the SOLiD Technology repeaters must understand and obey the following:

- Obey all general and regional installation and safety regulations relating to work on high voltage installations, as well as regulations covering correct use of tools and personal protective equipment.
- The power supply unit in repeaters contains dangerous voltage level, which can cause electric shock. Switch the mains off prior to any work in such a repeater. Any local regulations are to be followed when servicing repeaters.
- The repeater cover should be (door) securely fastened in open position, e.g. by tying it up, at outdoor work in order to prevent door from slamming due to wind causing bodily harm or damage.
- Use this unit only for the purpose specified by the manufacturer. Do not carry out any modifications or fit any spare parts which are not sold or recommended by the manufacturer. This could cause fires, electric shock or other injuries.
- Any repeater, including this repeater, will generate radio signals and thereby give rise to electromagnetic fields that may be hazardous to the health of any person who is extensively exposed to the signals at the immediate proximity of the repeater and the repeater antennas.
- Due to power dissipation, repeater may reach a very high temperature. Do not operate this unit on or close to flammable materials.
- Do not use any solvents, chemicals, or cleaning solutions containing alcohol, ammonia, or abrasives.
- Certification
 - FCC: This equipment complies with the applicable sections of Title 47 CFR Parts 15,22,24 and 90
 - UL/CUL: This equipment complies with UL and CUL 1950-1 Standard for safety for information technology equipment,including electrical business equipment
 - FDA/CDRH: This equipment uses a Class 1 LASER according to FDA/CDRH Rules.This product conforms to all applicable standards of 21 CFR Chapter 1, Subchapter J, Part 1040
- For PLUGGABLE EQUIPMENT, the socket-outlet shall be installed near the equipment and shall be easily accessible.

Section 2

System Overview

-
- 2.1 General overview**
 - 2.2 System overview**

2.1 General overview

SMDR-NH124 is a coverage system for in-building services delivering voice and data in high quality and for seamlessly.

As a distributed antenna system, it provides analog and digital phone systems that are served in multiple bands through one antenna.

The system covers general public institutions and private facilities.

- Shopping malls
- Hotels
- Campus areas
- Airports
- Clinics
- Subways
- Multi-use stadiums, convention centers, etc.

The system helps improve in-building radio environments in poor condition and make better poor RSSI and Ec/Io. By providing communication services at every corner of buildings, the system enables users to make a call at any site of buildings.

The system uses both analog (AMPS) and digital (TDMA, CDMA and WCDMA) methods.

The SMDR-NH124 system supports communication standards and public interface protocols in worldwide use.

- Frequencies: VHF,UHF, 700MHz, 800MHz,850MHz 900MHz,1900MHz,2100MHz, etc.
- Voice protocols: AMPS,TDMA, CDMA,GSM,IDEN, etc.
- Data protocols: EDGE,GPRS,WCDMA,CDMA2000,Paging, etc.

SMDR-NH124 is in modular structure per frequency. To provide desired frequency in a building, all you need to do is to insert a corresponding frequency module into each unit. As it delivers multiple signals with one optical cable, the system, in one-body type, does not require additional facilities whenever new frequency is added.

The system is featured with the following:

- Flexibility & Scalability
 - Support fiber-optic ports up to 39
 - Clustering multiple-buildings (campus) as one coverage
- Modular structures
 - Modular frequency upgrade
 - Plug-in type module
- Multi-Band, Multi Operator

- Signals with a plurality of service provider transmit simultaneously
- Support multi-operator in a band
- Low OPEX / CAPEX
 - Compact design
 - Upgradable design
 - Easy installation and maintenance
 - Web Based SNMP or GSM Modem or UDP support (Optional)

2.2 System overview

SMDR-NH124 is composed of devices given below.

Basically, the system consists of BIU (BTS Interface Unit), ODU (Optic distribution Unit) and ROU (Remote Optic Unit). For addition of more ROUs, it has OEU (Optic Expansion Unit).

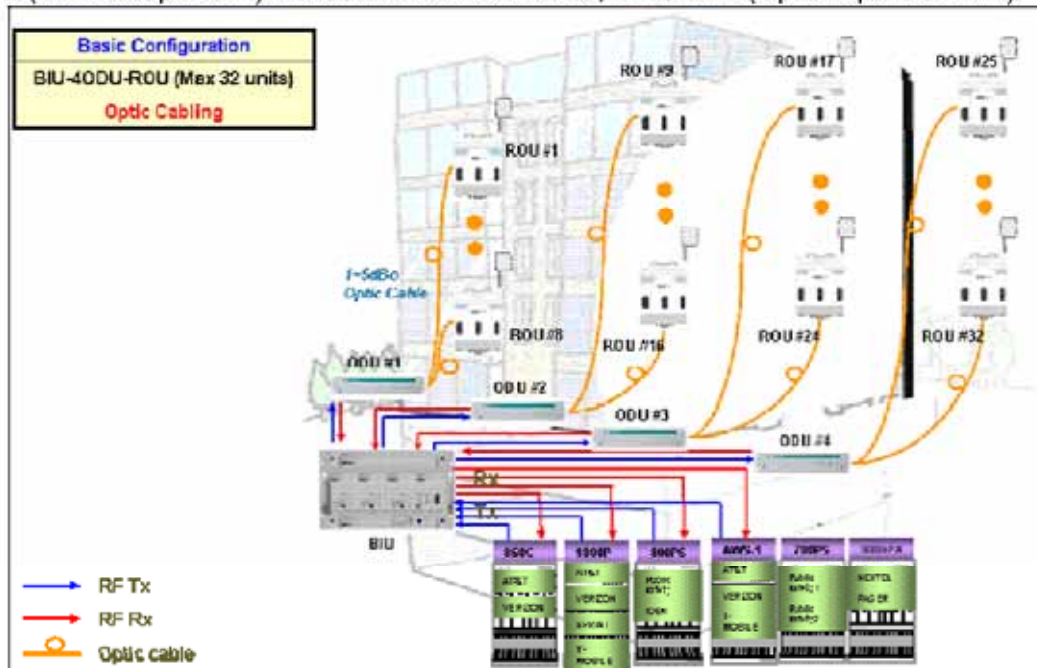

Figure 2.1 – Basic system topology

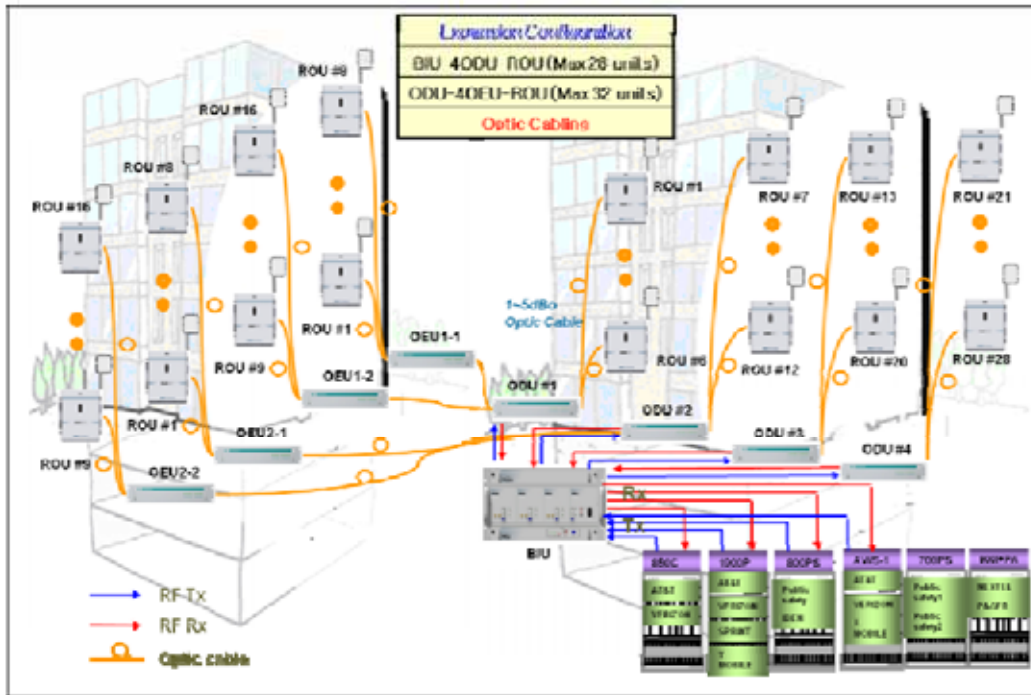

Figure 2.2 – Expansion system topology

Table 3.1 – System topology Charts

System elements	Optical Loss [dBo]	Max. RUs
BIU – ODU(DOUx1) – ROU	1~5dBo	4
BIU – ODU(DOUx2) – ROU	1~5dBo	8
BIU – 4ODU(DOUx2) – ROU	1~5dBo	32
BIU – 4ODU(DOUx2)-4OEU(DOUx2) – ROU	1~5dBo	60

Section 3

System Specifications

- 3.1 System specifications**
 - 3.1.1 Physical Specifications**
 - 3.1.2 Optic wavelength and Laser power**
 - 3.1.3 Environmental specifications**
 - 3.1.4 Operating Frequencies range**
 - 3.1.5 Specifications Per band**

3.1 System specifications

3.1.1 Physical Specifications

Parameter	BIU	ODU	OEU	ROU	AOR
RF Connectors	4 SMA type, female (Per MDBU)	2 SMA type, female	-	1N-type, female	2 SMA Type female
External Alarm connector (Dry contacts)	Terminal block, 3pcs	-	-	-	-
Serial Interface connector	1 RS-232 9-pin D-sub, male		1 RS-232 9-pin D-sub, male	1 RS-232 9-pin D-sub, male	-
Fiber connector	-	8pcs, SC/APC for ROU	1 SC/APC for ODU 8 SC/APC for ROU	1 SC/APC for ODU	-
LED Alarm and Status Indicator	<p>MDBU Status</p> <ul style="list-style-type: none"> Power On status ALM status <p>MCPU</p> <ul style="list-style-type: none"> Power On status TX Communication RX Communication ALM status <p>MPSU</p> <ul style="list-style-type: none"> Power On status DC ALM status 	<p>DOU1 Status</p> <ul style="list-style-type: none"> LD status PD1/2/3/4 status <p>DOU2 Status</p> <ul style="list-style-type: none"> LD status PD1/2/3/4 status 	<p>EWDM Status</p> <ul style="list-style-type: none"> LD status PD status <p>DOU1 Status</p> <ul style="list-style-type: none"> LD status PD1/2/3/4 status <p>DOU2 Status</p> <ul style="list-style-type: none"> LD status PD1/2/3/4 status <p>System status</p> <ul style="list-style-type: none"> Power on status TX Communication RX Communication 	<p>System status</p> <ul style="list-style-type: none"> Power on status TX1 Communication RX1 Communication TX2 Communication RX2 Communication ALM status 	-
AC Power	-	-		Normal Range: 120VAC 50/60Hz Operating range 108-132VAC, 50/60Hz	Same left side
DC Power	Normal range: -48 VDC Operating range: -40.8 ~ -57.6VDC	-		Normal: -48 VDC Operating range: -40.8 ~ -57.6VDC	Same to left side
Power consumption	168W (including ODU 4EA)	-	48W (including DOU2EA)	265W (including RDU 3EA)	78W (VHF/UHF RDU)
Enclosure Dimensions	482.6(19") x 221.5(5U) x 450	482.6(19") x 43.6(1U) x 450	482.6(19") x 88.1(2U) x 450	420 x 530 x 258	482.6(19") x 258 x 177
Weight[Full Load]	22.25Kg	5.7Kg	9.3Kg	35.45Kg	11Kg

3.1.2 Optic wavelength and Laser power

Parameter	ODU	OEU	ROU
Wavelength	TX: 1310nm RX: 1550nm	West optic TX: 1550nm, RX: 1310nm East optic TX: 1310nm, RX: 1550nm	TX: 1550nm RX: 1310nm
Output power	3dBm±1dBm to ROU,OEU	3dBm±1dBm to ROU 7dBm±1dBm to ODU	7dBm±1dBm to ODU

3.1.3 Environmental specifications

Parameter	BIU, ODU, OEU	ROU/AOR
Operating Temperature	-10 to +50°C	-10 to +50°C
Operating Humidity, non condensing	-	5% to 90%

3.1.4 Operating Frequencies range

Standard	Unit naming	Description	Frequency range	
			TX(MHz)	RX(MHz)
IDEN	700P	Public safety	764 to 776	794 to 806
IDEN	800P	Public safety	851 to 869	806 to 824
Cellular	850C	Cellular	869 to 894	824 to 849
Iden	900I	SMR	929 to 940	896 to 902
Paging	900 PA	Paging	929 to 930	896 to 902
PCS	1900P	PCS	1930 to 1995	1850 to 1915
AWS-1	AWS-1	AWS-1	2110 to 2155	1710 to 1755
-	VHF	Public safety	136 to 174	136 to 174
-	UHF	Public safety(Band1)	396 to 450	396 to 450
-			450 to 512	450 to 512
-		Public safety(Band2)	380 to 434	380 to 434
-			434 to 496	434 to 496
LTE	700LTE	Long Term Evolution	728 to 757	698 to 716 777 to 787

3.1.5 Specifications Per band

700MHz Long Term Evolution

Parameters		Typical		Remarks
		TX	RX	
Bandwidth		29MHz	28MHz	RX(MHz): 698-716 777-787
System ripple		≤5dB	≤5dB	
Input Power level		-20 to +10dBm	≤-50dBm	
Output power	SISO	+30dBm	+0dBm	Total
	MIMO(MAIN)	+30dBm	+0dBm	
	MIMO(MIMO)	+26dBm	+0dBm	
System Gain		43dB	50dB	
Gain Control range		18 to 43dB	30 to 50dB	
IM3		-13dBm	-	
IP3		-	+23dBm	
Noise figure		-	15dB	1ROU

700MHz Public safety

Parameters		Typical		Remarks
		TX	RX	
Bandwidth		12MHz	12MHz	
System ripple		≤5dB	≤5dB	
Input Power level		-20 to +10dBm	≤-50dBm	
Output power		+23dBm	+0dBm	Total
System Gain		43dB	50dB	
Gain Control range		18 to 43dB	30 to 50dB	
IM3		-13dBm	-	
IP3		-	+23dBm	
Noise figure		-	15dB	1ROU

800MHz Public safety

Parameters	Typical		Remarks
	TX	RX	
Bandwidth	18MHz	18MHz	
System ripple	≤5dB	≤5dB	
Input Power level	-20 to +10dBm	≤-50dBm	
Output power	+23dBm	+0dBm	Total
System Gain	43dB	50dB	
Gain Control range	18 to 43dB	30 to 50dB	
IM3	-13dBm	-	
IP3	-	+23dBm	
Noise figure	-	15dB	1ROU

850MHz Cellular

Parameters	Typical		Remarks
	TX	RX	
Bandwidth	25MHz	25MHz	
System ripple	≤5dB	≤5dB	
Input Power level	-20 to +10dBm	≤-50dBm	
Output power	+23dBm	+0dBm	Total
System Gain	43dB	50dB	
Gain Control range	18 to 43dB	30 to 50dB	
IM3	-13dBm	-	
IP3	-	+23dBm	
Noise figure	-	15dB	1ROU

900MHz iDEN & Paging

Parameters	Typical		Remarks
	TX	RX	
Bandwidth	12MHz	6MHz	
System ripple	≤5dB	≤5dB	
Input Power level	-20 to +10dBm	≤-50dBm	
Output power	+23dBm	+0dBm	Total
System Gain	43dB	50dB	
Gain Control range	18 to 43dB	30 to 50dB	
IM3	-13dBm	-	
IP3	-	+23dBm	
Noise figure	-	15dB	1ROU

1900MHz PCS

Parameters	Typical		Remarks
	TX	RX	
Bandwidth	65MHz	65MHz	
System ripple	≤5dB	≤5dB	
Input Power level	-20 to +10dBm	≤-50dBm	
Output power	+26dBm	+0dBm	Total
System Gain	50dB	50dB	
Gain Control range	25 to 50dB	30 to 50dB	
IM3	-13dBm	-	
IP3	-	+23dBm	
Noise figure	-	15dB	1ROU

1700MHz&2100MHz AWS-1

Parameters	Typical		Remarks
	TX	RX	
Bandwidth	45MHz	45MHz	
System ripple	≤5dB	≤5dB	
Input Power level	-20 to +10dBm	≤-50dBm	
Output power	+30dBm	+0dBm	Total
System Gain	50dB	50dB	
Gain Control range	25 to 50dB	30 to 50dB	
IM3	-13dBm	-	
IP3	-	+23dBm	
Noise figure	-	15dB	1ROU

150MHz VHF Public safety

Parameters	Typical		Remarks
	TX	RX	
Bandwidth	38MHz	38MHz	136~174MHz
System ripple	≤5dB	≤5dB	
Input Power level	-15 to +10dBm	≤-54dBm	
Output power	+24dBm	-4dBm	Total
System Gain	39dB	50dB	
Gain Control range	14 to 39dB	30 to 50dB	
IM3	-13dBm	-	
IP3	-	+23dBm	
Noise figure	-	7dB	1ROU

450MHz UHF Public safety

Parameters	Typical		Remarks
	TX	RX	
Bandwidth(Band1)	116MHz	116MHz	396~450MHz(54MHz) 450~512MHz(62MHz) Band selection
Bandwidth(Band2)	116MHz	116MHz	380~434MHz(54MHz) 434~496MHz(62MHz) Band selection
System ripple	≤5dB	≤5dB	
Input Power level	-15 to +10dBm	≤-54dBm	
Output power	+24dBm	-4dBm	Total
System Gain	39dB	50dB	
Gain Control range	14 to 39dB	30 to 50dB	
IM3	-13dBm	-	
IP3	-	+23dBm	
Noise figure	-	7dB	1ROU

Section 4

System Configuration and Functions

-
- 4.1 BIU (BTS Interface Unit)**
 - 4.2 ODU (Optic distribution Unit)**
 - 4.3 OEU (Optic Expansion Unit)**
 - 4.4 ROU (Remote Optic Unit)**
 - 4.5 AOR (Add on V/UHF ROU)**

4.1 BIU (BTS Interface Unit)

BIU provides TX signals from BTS or BDA for four ODUs (Optic Distribution Unit). This unit separates RX signals given from ODUs from each other per frequency band.

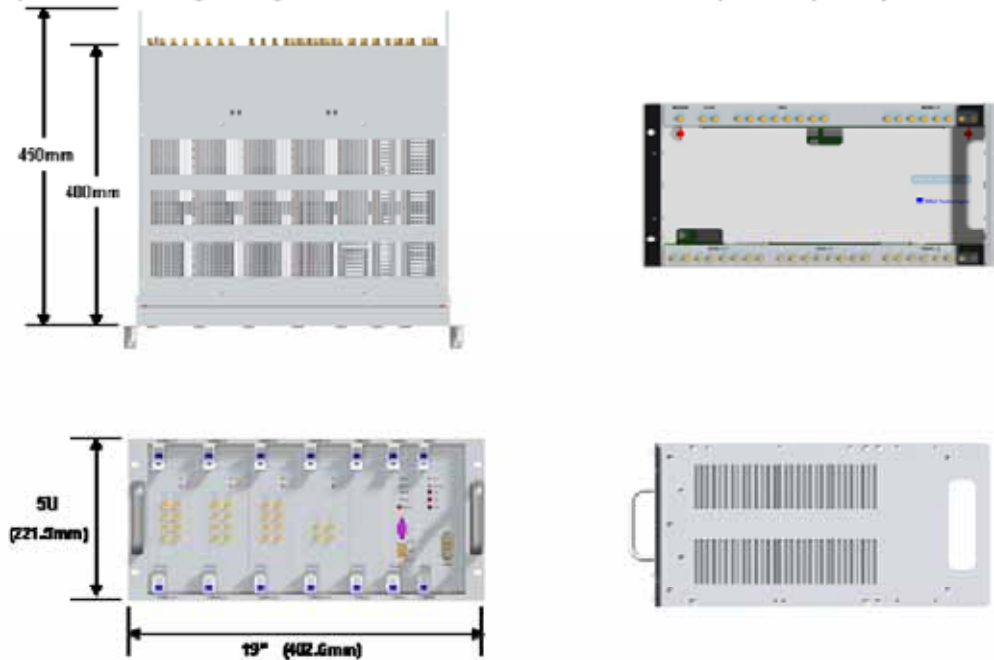
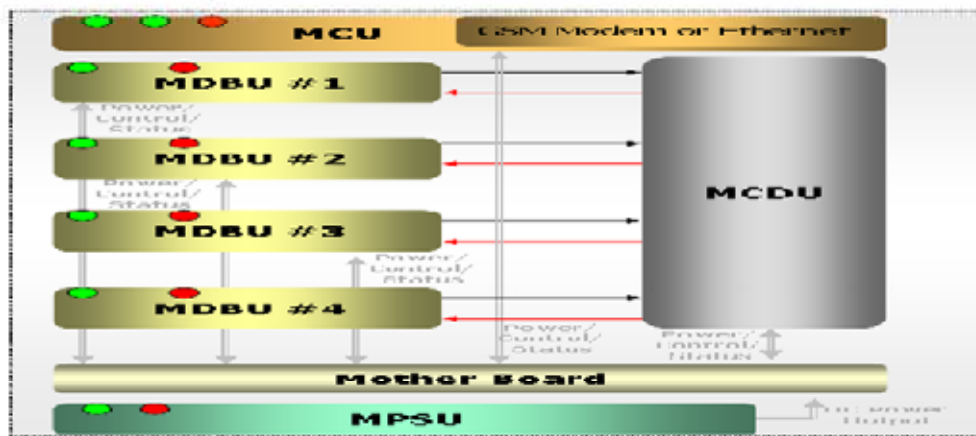

Figure 4.1 – BIU outer view

4.1.1 Specifications of BIU

Item	Spec.	Remark
Size	482.6(19") x 221.5(5U) x 450	Mm
Weight	22.35 Kg	Full Load
Power consumption	168 W	

4.1.2 Block diagram of BIU



4.1.3 BIU parts

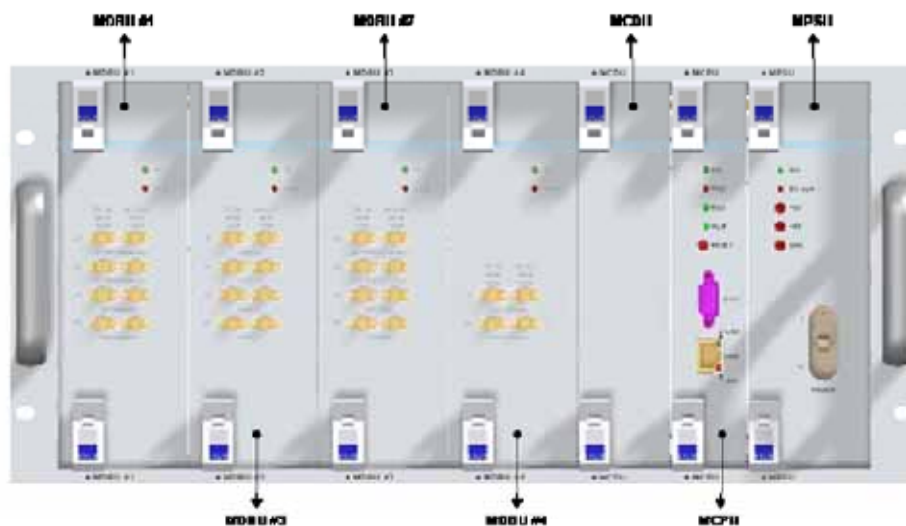

Figure 4.2 – BIU mounting diagram

No.	Unit	Description	Remark
1	MDBU	Main Drive BTS Unit Amplify & adjust downlink RF signal Amplify & adjust uplink RF signal	Max 4EA
2	MCDU	Main Com/Div Unit Combine 4EA downlink signal and divide 4EA signal to ODU Combine 4EA uplink signal and divide 4EA signal to MDBU Support VHF/UHF interface port	

3	MCPU	Main Central Processor Unit Control and monitoring system status Control and monitoring with RS232 Have an access to upper-level network through GSM or Ethernet
4	MPSU	Main Power Supply Unit Input power: DC -48V, Output power: 9V, 6V
5	M/B	Mother Board Provide signal interface and power for each unit Provide three ports for dry contact
6	Shelf	19 inch, 5U

4.1.4 Function by unit

1) Main Drive BTS Unit (MDBU)

MDBU delivers TX signals of BTS or BDA to related devices and then delivers RX signals of the devices to BTS or BDA. This unit can monitor TX input level. Using input AGC function, it automatically adjusts input ATT. It also has ATT to adjust RX gain. MDBU is varied per frequency band including the following:

No	Unit naming	Description	In/out RF Port	
			TX	RX
1	800PS	Single Band	2 Port	2 Port
2	850C	Single Band	2 Port	2 Port
3	1800P	Single Band	4 Port	4 Port
4	AWS-1	Single Band	4 Port	4 Port
5	800PS+900I+PA	Dual Band	4 Port	4 Port
6	850C+700PS	Dual Band	4 Port	4 Port
7	850C+700LTEC	Dual Band	4 Port	4 Port
8	700LTEF SISO	Single Band	2 Port	2 Port
9	700LTEF MIMO	Single Band	4 Port	4 Port



800PS



800PS+900I+Paging



1900PCS



AWS-1



850C



850C+700PS



850C+700LTEC

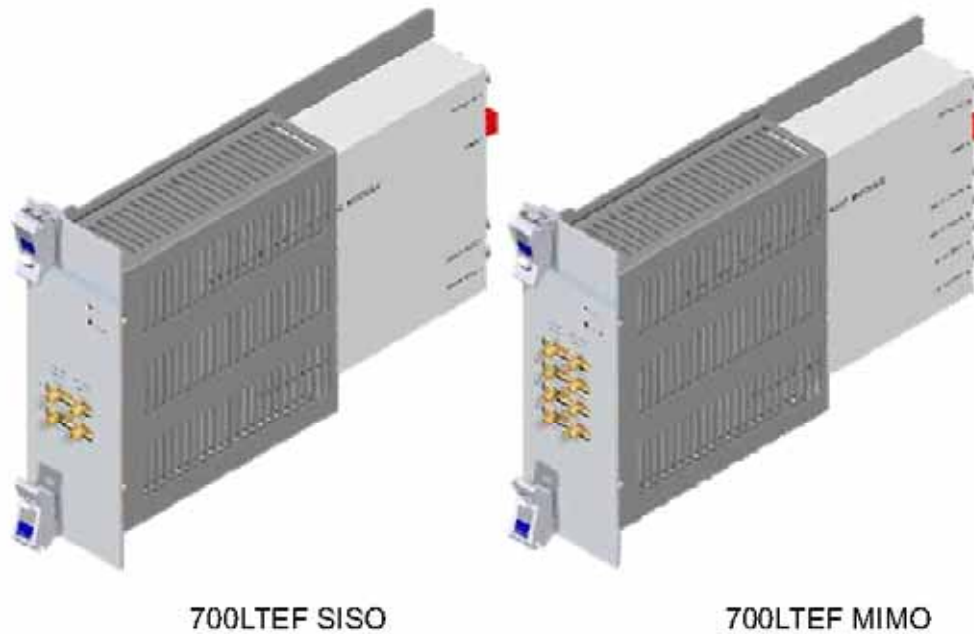

Figure 4.3 – MDBU Outer Look

2) Main Com/Div Unit (MCDU)

MCDU combines TX signals that are delivered from MDBU per frequency band and delivers the signals to four ODUs. This unit adds signals of FSK modem to the TX signals before sending them to ROU. It also combines RX signals from up to four ODUs and sends them to up to four MDBUs. In this case, the unit extracts signals of FSK modems, which are sent in a combined form with RX signals, and then delivers the signals to MCU.

The unit has a port to interface with VHF&UHF signals. It has ATT for input monitoring and input control.

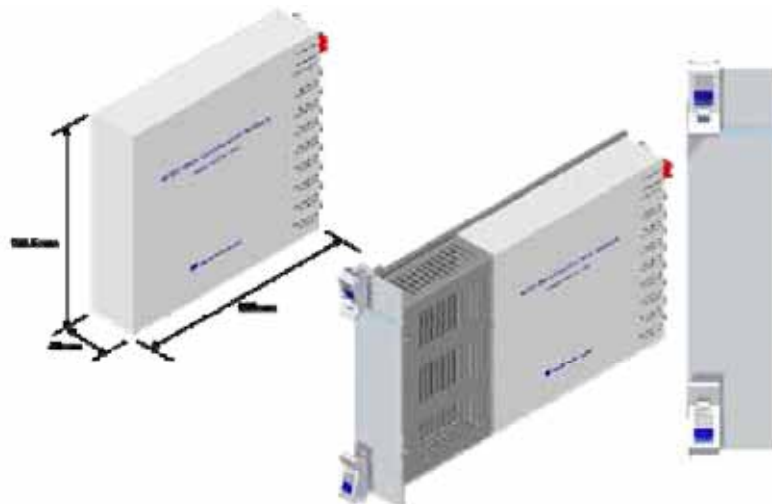

Figure 4.4 – MDBU Outer Look

VHF+UHF frequency band including the following:

No	Unit naming	Description	In/out RF Port	
			TX	RX
1	VHF+UHF	Dual Band	1 Port	1 Port

3) Main Central Processor Unit (MCPU)

MCPU can inquire and control state of modules that are installed in BIU.

This unit can inquire and control state of four ODUs in total. Through communication, it also can inquire and control ROU that is connected with lower parts.

In addition, the unit has RS-232C port for serial communication so that it can inquire and control state of devices through PC. On the front panel, it has communication LED indicator to check communication state with ROU. It also has ALM LED indicator to show whether a device gets faulty.

For access to upper network, it has a port to insert Ethernet port and GSM modem in it.



Figure 4.5 – MCPU Outer Look

In the Main Central Processor Unit, a lithium battery is installed for RTC (Real Time Control) function.



RISK OF EXPLOSION IF BATTERY IS REPLACED BY AN INCORRECT TYPE
 DIPOSE OF USED BATTERIES ACCORDING TO THE INSTRUCTIONS
 [INSTRUCTION]

The equipment and accessories including inner lithium battery are to be disposed of safely after

the life span of them and national regulation must be observed. Do not attempt to replace the lithium battery unless service personnel confirmation has first been obtained, to avoid any risk of explosion.

4) Main Power Supply Unit (MPSU)

MPSU receives -48V of input and outputs +6V and +9V of DC power.

On the front panel, this unit has an output test port and it also has DC ALM LED Indicator to show whether output gets faulty.



Figure 4.6 – MPSU Outer Look

4.1.5 Front/rear panels of BIU

1) **Front panel**



Figure 4.7 – BIU front panel Outer Look

Item	Description
1. MDBU LED	LED to show whether MDBU is installed and gets faulty
2. RF Monitor Port	20Db Coupling compared with TX Input Level 20Db Coupling compared with RX Output Level
3. Alarm LED & Reset	Communication state with devices, alarm status of the system and reset switch
4. NMS(RS-232C port)	RS-232C port for communication and diagnosis of devices through PC/laptop
5. NMS(Ethernet port)	Ethernet port for upper network This equipment is indoor use and all the communication wirings are limited to inside of the building
6. Pwr Test Port & ALM	Output DC power test port and ALM LED to show abnormal state, if any
7. Power switch	Power ON/OFF switch

2) Rear panel

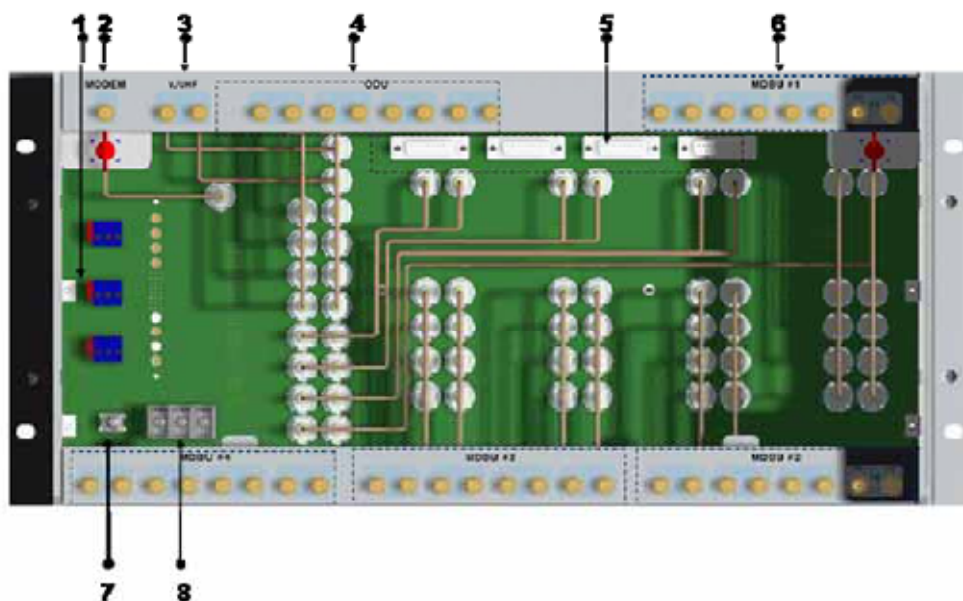

Figure 4.8 – Rear panel Outer Look

Item	Description
1. External ALM Port	Input/output terminal for dry contact
2. GSM Modem Port	GSM Modem terminal for upper network (Optional)
3. V/UHF I/O Port	RF signal interface terminal of VHF&UHF

4. ODU I/O Port	RF signal interface terminal for ODU
5. ODU signal Port	Power and signal interface terminal for ODU
6. BTS/BDA I/O Port	Input/output interface terminal of BTS/BDA
7. GND Port	System ground terminal
8. DC Input Port	Input terminal for DC -48V

4.2 ODU (Optic distribution Unit)

ODU receives TX RF signals from upper BIU and converts them into optical signals. The optical signals are sent to ROU through optical cables. This unit converts optical signals from ROU into RF signals and sends the converted signals to BIU.

For each shelf of the ODU, up to two DOUs (Donor Optic Unit) can be installed in it.

One DOU is supported with four optical ports. Therefore, one ODU can be connected with eight ROUs.

Up to four ODUs can be connected with BIU.

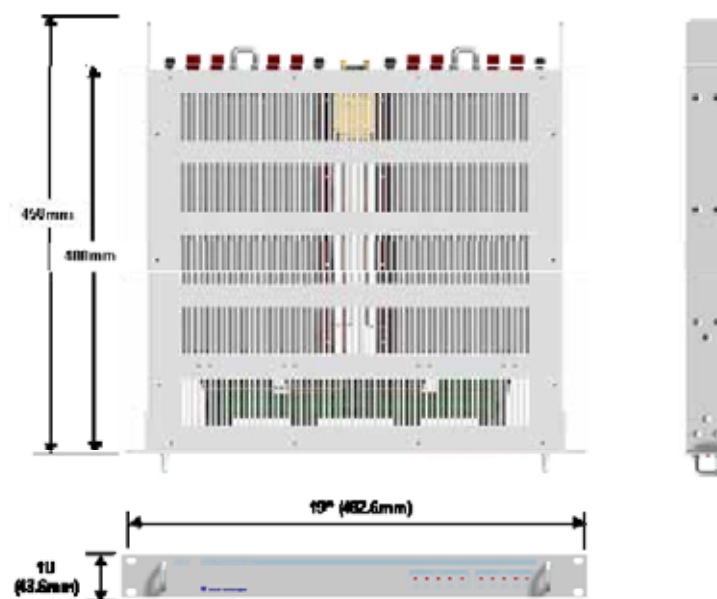

Figure 4.9 – ODU Outer Look

4.2.1 Specifications of ODU

Item	Spec.	Remark
Size	482.6(19") x 43.6(1U) x 450	Mm
Weight	5.7 Kg	Full Load
Power consumption	27 W	

No.	Unit	Description	Remark
1	DOU	DOU Convert TX RF signals into optical signals; Convert RX optical signals into RF signals; Provide up to four optical ports per DOU	Max 2ea
2	2W	2Way Divider Divide TX RF signals into two; Combine two RX RF signals into one	
3	DU	Distribution Unit Distribute power and signals to DOU	
4	Shelf	19" rack, 1U	
5	Accessories	15PIN DSUB, Male to female 1pcs RF Coaxial Cable Assembly 2pcs	

4.2.4 Function by unit

1) Donor Optic Unit (DOU)

DOU makes electronic-optical conversion of TX signals and makes optical-electronic conversion of RX signals.

With an optic splitter in it, this unit divides optical signals from Laser Diode into four and then distributes them to each optical port. With a total of four Photo Diodes in RX, DOU makes optical-electronic conversion of signals received from each optical port. In addition, the unit is equipped with ATT for optical compensation made in case of optical cable loss.

With internal WDM, it uses only one optical cable to be connected with ROU.



Figure 4.11 – MDBU Outer Look

2) 2Way Divider (2W)

2W is equipped with two 2-way splitters in a one-module form and the splitters work for TX/RX signals, respectively.

Designed in broadband type, the divider combines and divides 2GHz or higher of signals from FSK modem signals.

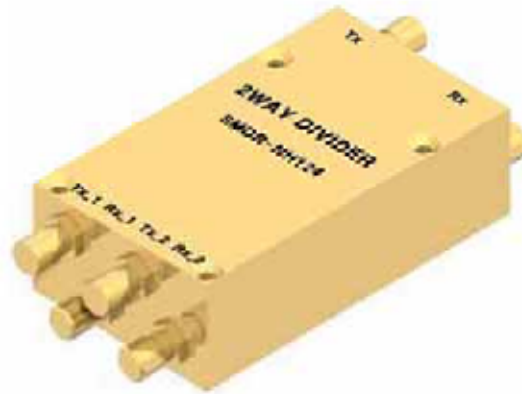

Figure 4.12 – 2Way Divider Outer Look

4.2.5 Front/rear panels of ODU

1) **Front panel**



Figure 4.13 – ODU front panel Outer Look

Item	Description
1,2	LED indicator to check DOU module state to see if it is abnormal

2) **Rear panel**

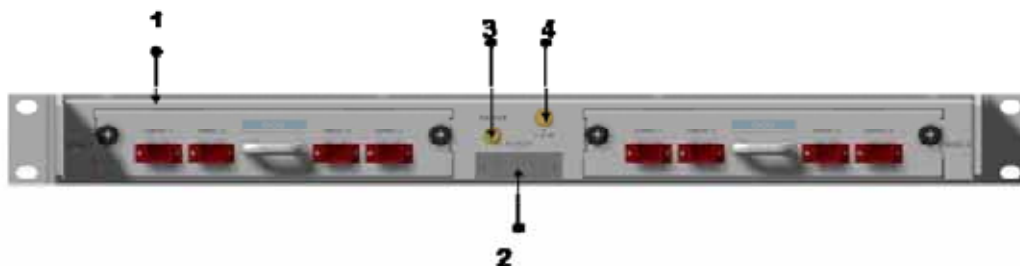

Figure 4.14 – ODU Rear panel Outer Look

Item	Description
1. Optic Port	SC/APC optical connector terminal; use one optical cable per ROU.
2. DC I/O Port	Terminal to deliver power and state values
3. RX RF Port	RX RF signal interface terminal
4. TX RF Port	TX RF signal interface terminal

4.2.6 Interface with BIU



Figure 4.15 – Interface between BIU and ODU

On the top of BIU, up to four ODUs can be stacked.

In this case, it is recommended to stack the units at least 1U of an interval between BIU, for heat from BIU may climb up to ODU, which may cause flame.

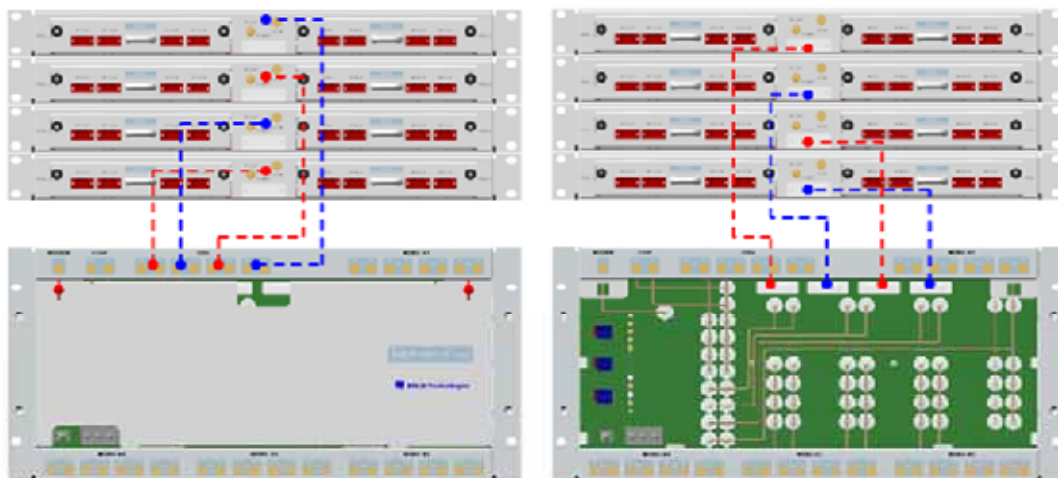

As seen in the figure below, connect the coaxial cable for TX and another coaxial cable for RX with corresponding ports at the rear of BIU. For power supply and communication, connect 15Pin D-Sub Connector cable with a corresponding port.

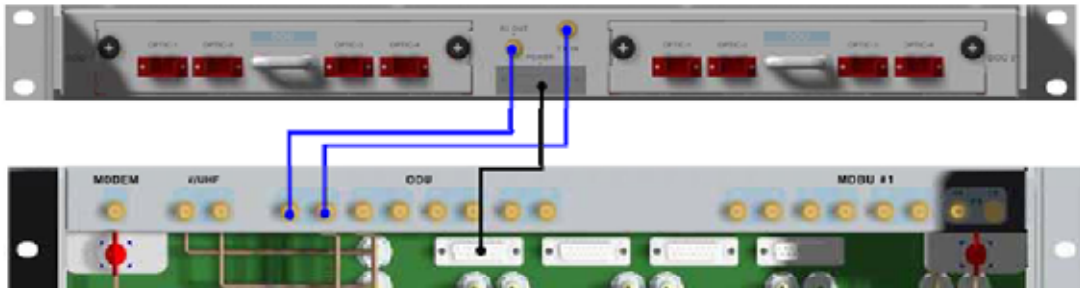

4.3 OEU (Optic Expansion Unit)

OEU is mainly used to remotely deliver signals for Campus clusters. At the upper part, this unit combines with ODU and receives TX optical signals to convert them into RF signals. Then, it regenerates the signals to secure S/N feature and converts them into optical signals. The signals are sent to ROU through optical cables. When it receives RX optical signals from ROU, the unit converts them into RF signals to regenerate the signals and then converts them into optical signals to send them to ODU.

In OEU, one shelf can be equipped with up to two DOUs. The DOU is the same as the module used for ODU. Up to two OEUs can be connected with ODU.

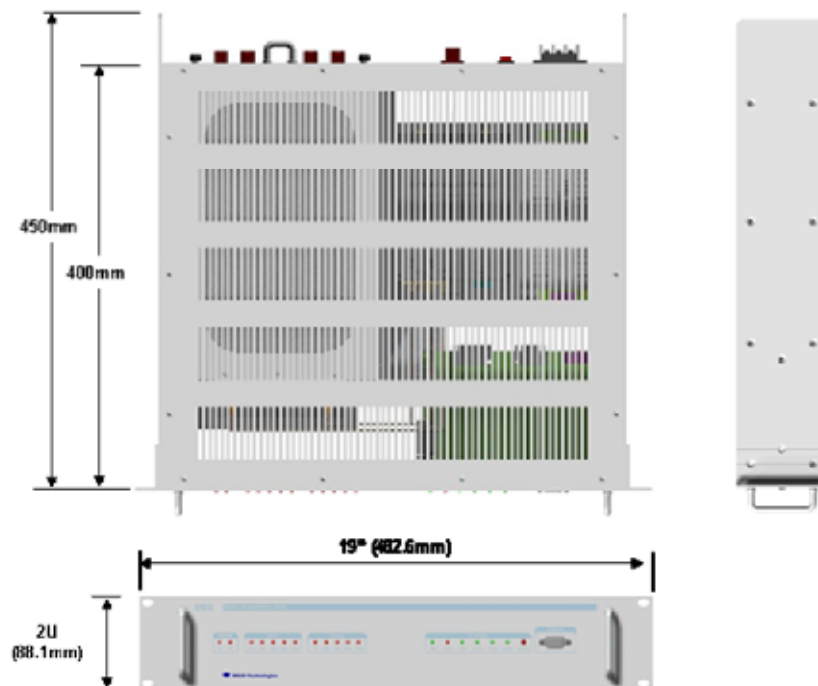
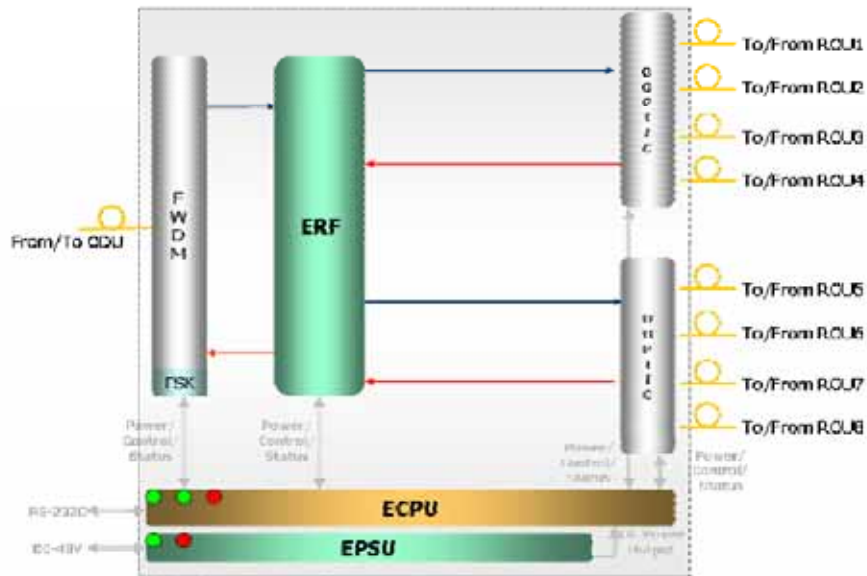

Figure 4.16 – OEU Outer Look

4.3.1 Specifications of OEU

Item	Spec.	Remark
Size	482.6(19") x 88.1(2U) x 450	mm
Weight	9.3 Kg	Full Load
Power consumption	48 W	

4.3.2 Block Diagram of OEU



4.3.3 OEU parts

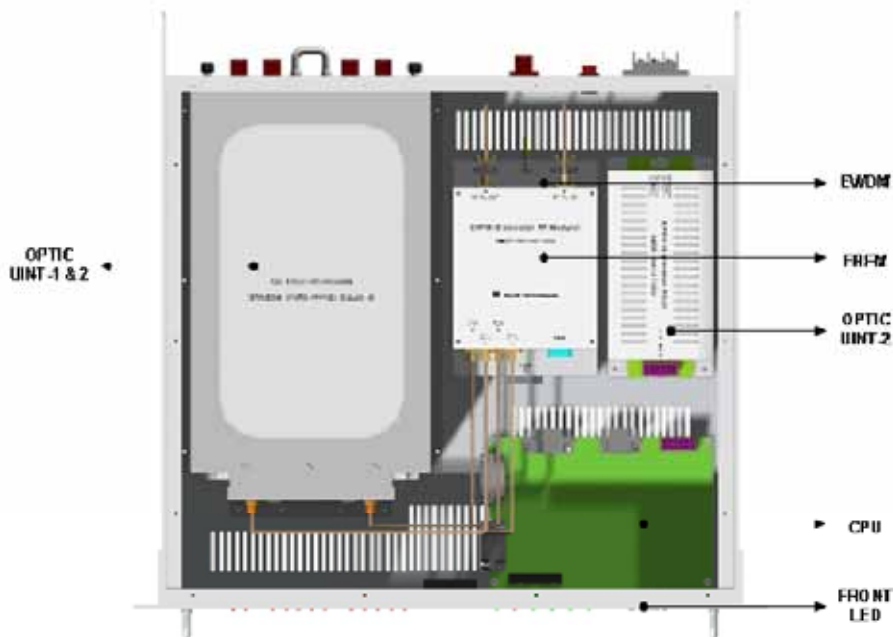

Figure 4.17 – OEU Inner Look

No.	Unit	Description	Remark
1	DOU	Donor Optic Unit Convert TX RF signals into optical signals; Convert RX optical signals into RF signals; Provide up to four optical ports per DOU	Max 2ea
2	EWDM	Expansion Wavelength Division Multiplexer Convert TX optical signals into RF signals; Convert RX RF signals into optical signals; Compensate for optical cable loss with ODU	
3	ECPU	Expansion Central Processor Unit Control and monitoring system status Control and monitoring with RS232 Relay state values of ROU to BIU	
4	EPSU	Expansion Power Supply Unit Input power: DC -48V, Output power: 9V, 6V	
5	ERFM	Expansion Radio Frequency Module Regenerate TX signals and transmit FSK modem signals; Regenerate RX signals and receive FSK modem signals	
6	Shelf	19" rack, 2U	

4.3.4 Function by unit

1) Donor Optic Unit (DOU)

DOU is the same as the module used for ODU.



Figure 4.18 – MDBU Outer Look

2) Expansion Wavelength Division Multiplexer(EWDM)

EWDM module makes optical-electronic conversion of TX signals and makes electronic-optical conversion of RX signals. With an FSK modem in it, this multiplexer communicates with BIU. It also has ATT for optical compensation to compensate for optical cable loss between ODUs. Furthermore, it has internal WDM, and so, it needs only one optical cable to work with ROU.

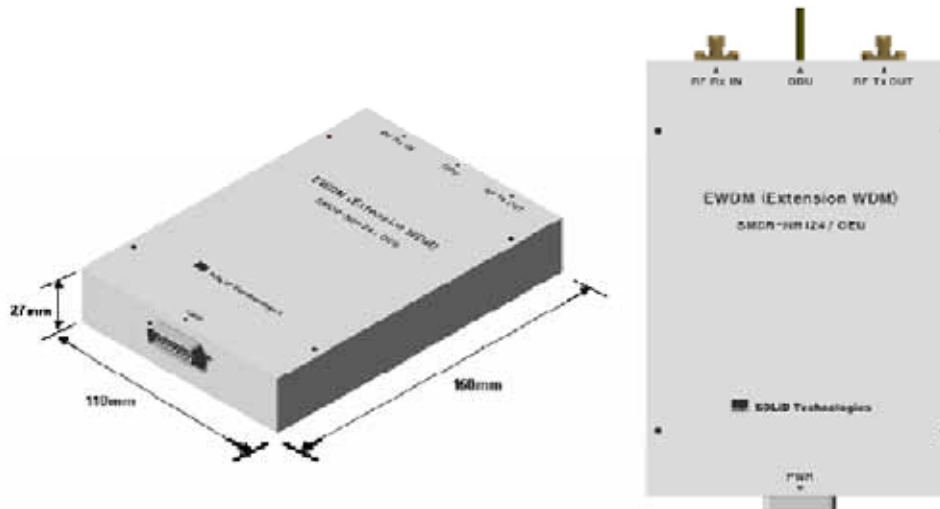

Figure 4.19 – EWDM Outer Look

3) Expansion Central Processor Unit(ECPU)

ECPU can inquire and control state of modules to be installed into OEU. This unit communicates with upper BIU while communicating with lower ROU. It also acts as communication bridge between BIU and ROU.

In addition, the unit has RS-232C port for serial communication, which enables inquiry and control of devices through PC. At the front panel, communication LED indicator indicates communication state with upper BIU and lower ROU. It also has ALM LED indicator to show if a device gets faulty.

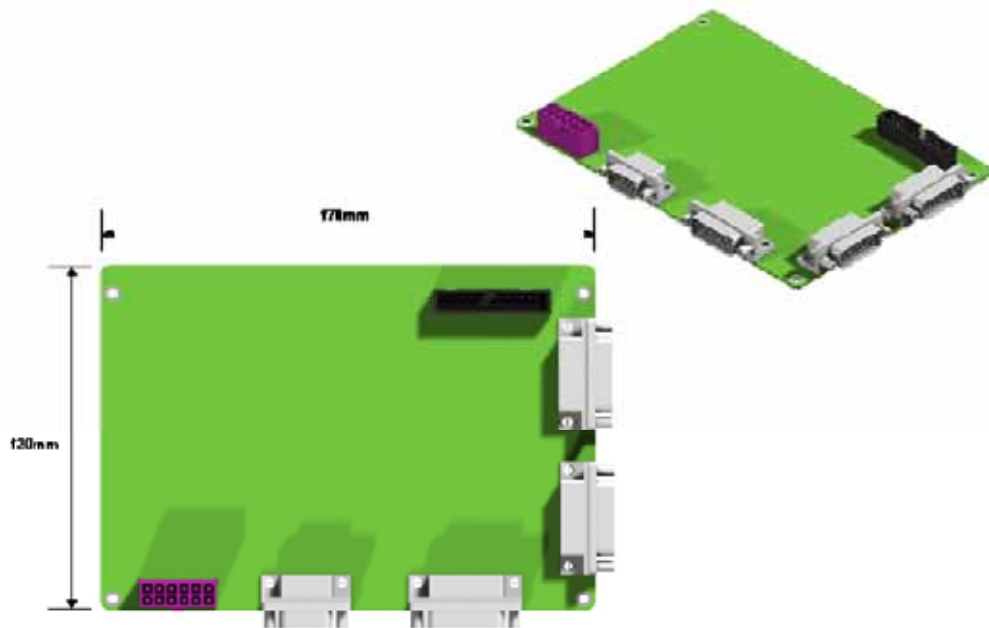

Figure 4.20 – ECPU Outer Look

4) Expansion Radio Frequency Module(ERFM)

ERFM reconstructs Signal to Noise degraded by optical modules. With an internal FSK modem, this module communicates with ROU.

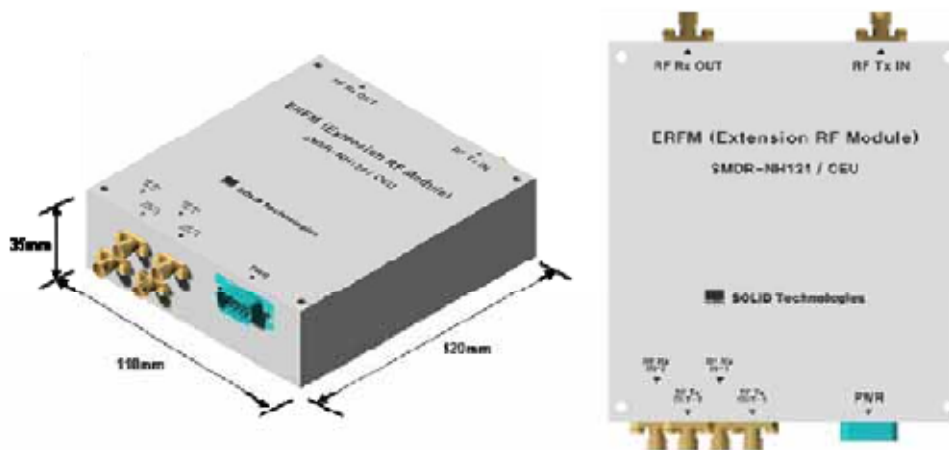

Figure 4.21 – ERFM Outer Look

5) Expansion Power Supply Unit(EPSU)

As DC/DC Converter, EPSU receives -48V of input and provides +9V and +6V of DC power required for OEU.

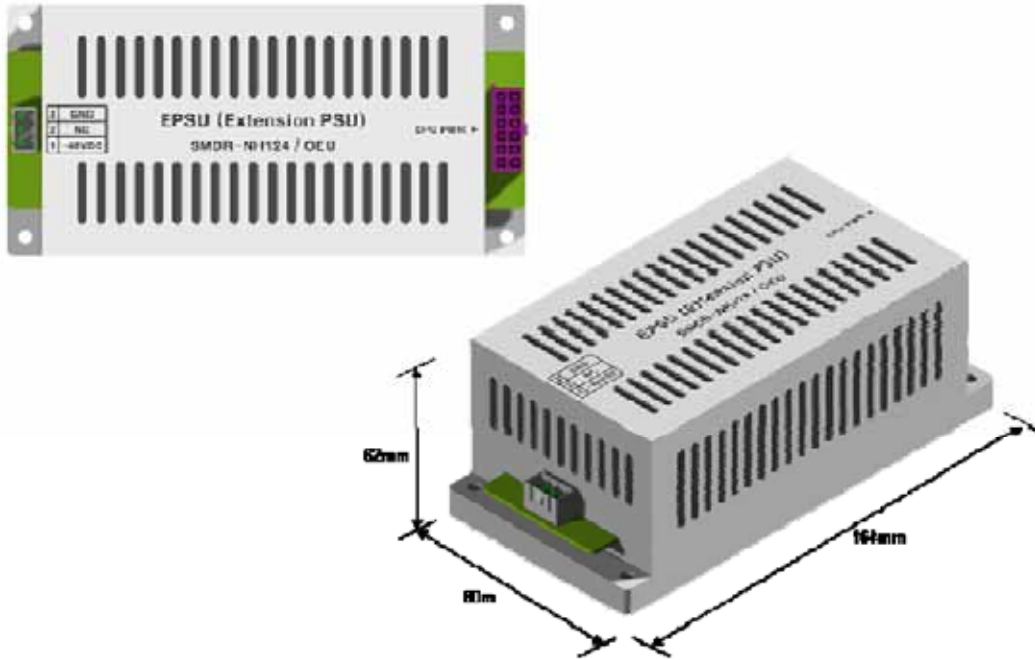

Figure 4.22 – ERFM Outer Look

4.3.5 Front/rear panels of OEU

1) Front panel



Figure 4.23 – OEU front panel Outer Look

Item	Description
1.EWDM LED	LED indicator to check EWDM state to see if it is abnormal
2.DOI LED	LED indicator to check DOI module state to see if it is abnormal
3.System LED and Reset	Communication state with devices, alarm status of the system and reset switch
4. NMS(RS-232C port)	RS-232C port for communication and diagnosis of devices through PC/laptop. This equipment is indoor use and all the communication wirings are limited to inside of the building

2) Rear panel

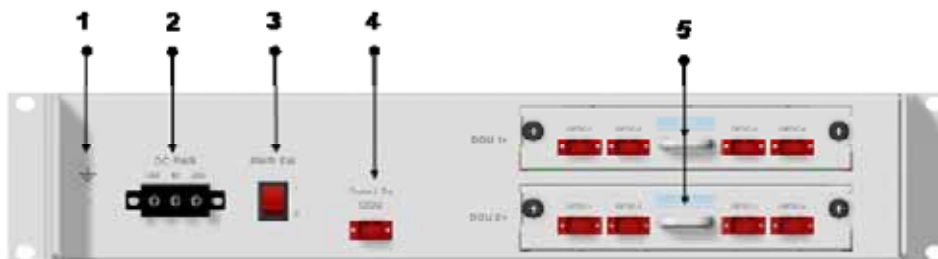

Figure 4.24 – Rear panel Outer Look

Item	Description
1. GND Port	Terminal for system ground
2. DC Input Port	Input terminal for DC -48V
3.power switch	Power ON/OFF switch
4. To/From ODU Optic Port	SC/APC optical connector terminal
5. To/From ROU Optic Port	SC/APC optical connector terminal; use one optical cable per ROU.

4.4 ROU (Remote Optic Unit)

ROU receives TX optical signals from ODU or OEU and converts them into RF signals. The converted RF signals are amplified through High Power Amp in a corresponding RDU, combined with Multiplexer module and then radiated to the antenna port.

When receiving RX signals through the antenna port, this unit filters out-of-band signals in a corresponding RDU and sends the results to Remote Optic Module to make electronic-optical conversion of them. After converted, the signals are sent to a upper device of ODU or OEU. ROU can be equipped with up to three RDUs (Remote Drive Unit) and the module is composed of maximal Dual Band.

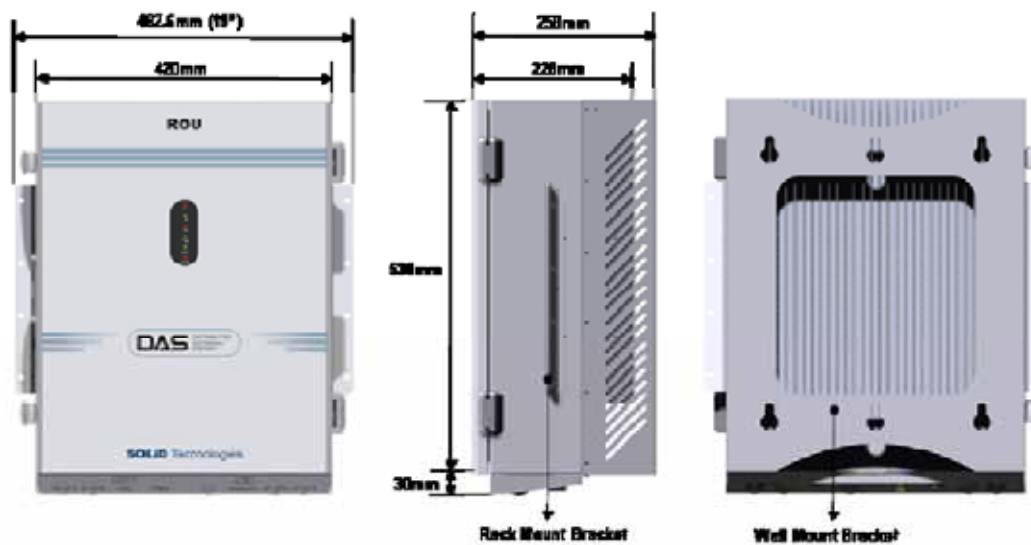

Figure 4.25 – ROU Outer Look

ROU is designed in a cabinet, and provides the following functions and features.

4.4.1 Specifications of ROU

Item	Spec.	Remark
Size(mm)	482.6(19") x 258 x560,	Including Bracket
Weight	35.45 Kg	Full Load
Power consumption	265 W	

4.4.2 Block Diagram of ROU

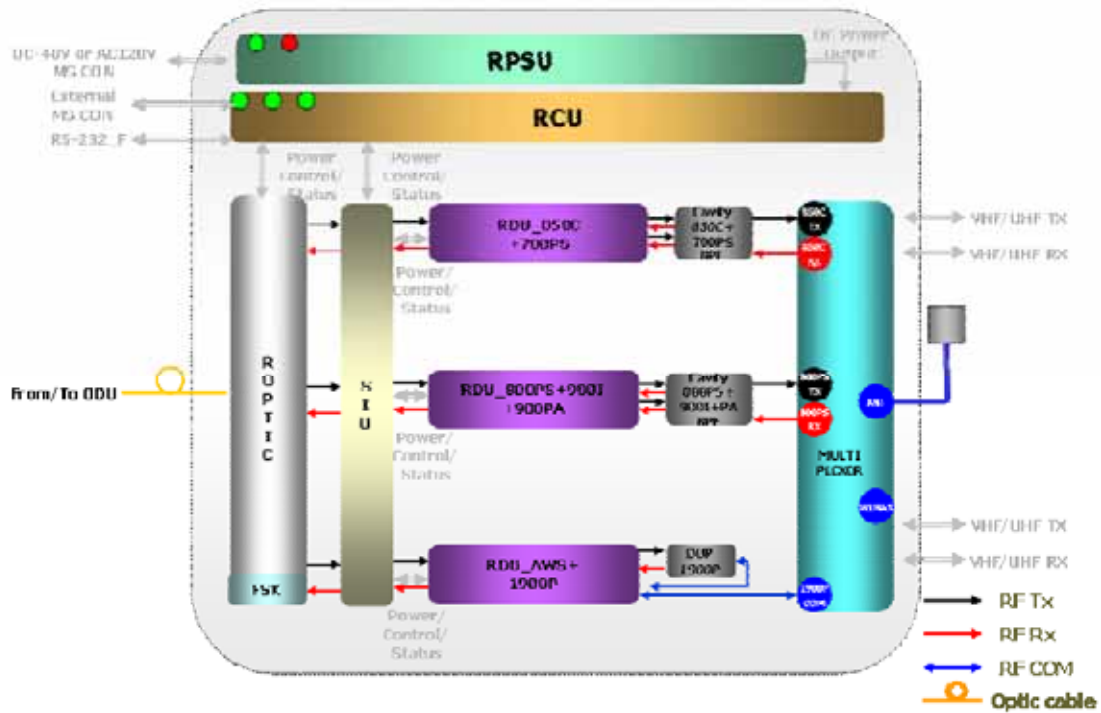

4.4.3 ROU parts

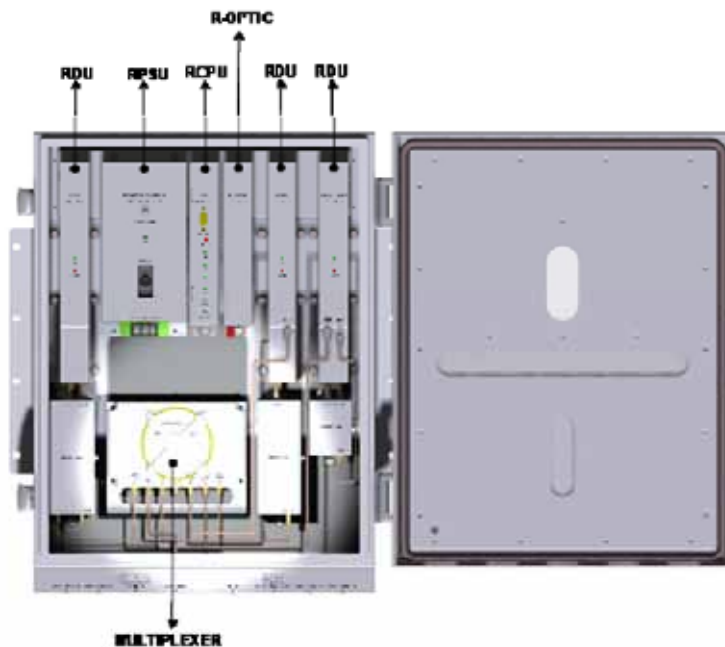

Figure 4.26 – ROU Inner Look

No.	Unit	Description	Remark
-----	------	-------------	--------

1	RDU+BPF	Remote Drive Unit Filter and high amplify TX signals; Filter and amplify RX signals; Remove other signals through BPF BPF is exclude from VHF+UHF module	
2	RPSU	Remote Power Supply Unit Input power: DC -48V, Output power: 27V,9V, 6V For 120V input of AC/DC; For -48V input of DC/DC	
3	R-OPTIC	Remote Optic Make RF conversion of TX optical signals; Convert RX RF signals into optical signals; Compensates optical loss Communicates with BIU/OEU though the FSK modem	
4	RCPU	Remote Central Processor Unit Controls signal of each unit Monitors BIU/ODU/OEU status through FSK modem communication	
5	Multiplexer	Multiplexer Combine TX signals from 3 RDUs; Distribute RX signals to 3 RDUs; Enable you to use a single antenna port	
6	Enclosure	Enclosure to satisfy NEMA4; Enable Wall/Rack Mount; Check if the system is normal, through the front panel LED	
7	SIU	System Interface Unit Distribute power and signals of each module	