

# Alliance 2W (Remote Unit)

Alliance\_2W\_L2ROU

## User Manual

---

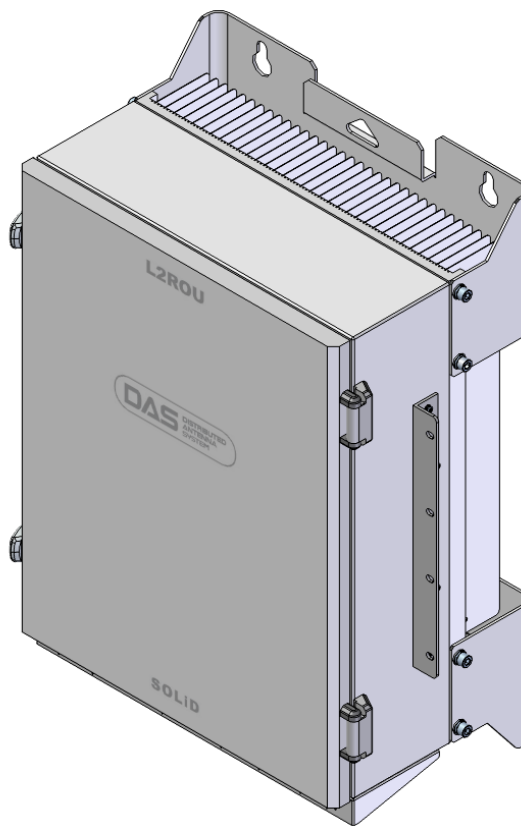

## REVISION HISTORY

Version	Issue Date	No. of Pages	Initials	Details of Revision Changes
V 1.0	Feb. 23, 2016		Original	

### Technical Support

SOLiD serial numbers must be available to authorize technical support and/or to establish a return authorization for defective units. The serial numbers are located on the back of the unit, as well as on the box in which they were delivered. Additional support information may be obtained by accessing the SOLiD Tehcnology, Inc. website at [www.st.co.kr](http://www.st.co.kr) or send email at [sjkim@st.co.kr](mailto:sjkim@st.co.kr)

This manual is produced by Global Business Division Business Team 1. Printed in Korea.

## Contents

<b>Section1</b>	<b>Safety &amp; Certification Notice .....</b>	<b>5</b>
<b>Section2</b>	<b>System Overview.....</b>	<b>9</b>
2.1	Purpose.....	10
2.2	Alliance 2W .....	11
2.3	Dimension.....	12
<b>Section3</b>	<b>System Installation.....</b>	<b>13</b>
3.1	L2ROU Installation .....	13
3.1.1	L2ROU Enclosure installation .....	13
3.1.2	L2ROU Power Cabling .....	18
3.1.3	Optical Cabling .....	19
3.1.4	GND Terminal Connection .....	20
3.1.5	Coaxial cable and Antenna Connection.....	21
3.1.6	Insertion of L2RDU.....	21
3.1.7	L2RDU Specifications Per band .....	22

## Contents of Figure

<b>Figure 3.1 – L2ROU Outer Look.....</b>	<b>12</b>
<b>Figure 3.2 – How to install L2ROU.....</b>	<b>14</b>
<b>Figure 3.3 – Dimension used to install L2ROU on the WALL .....</b>	<b>14</b>

# ***Section 1***

## **Safety & Certification Notice**

---

**“Only qualified personnel should handle the DAS equipment. Any person involved in installation or service of the DAS should understand and follow these safety guidelines.”**

- Obey all general and regional installation and safety regulations relating to work on high voltage installations, as well as regulations covering correct use of tools and personal protective equipment.
- The power supply unit in repeaters contains dangerous voltage level, which can cause electric shock. Switch the mains off prior to any work in such a repeater. Any local regulations are to be followed when servicing repeaters.
- When working with units outdoors, make sure to securely fasten the door or cover in an open position to prevent the door from slamming shut in windy conditions..
- Use this unit only for the purpose specified by the manufacturer. Do not carry out any modifications or fit any spare parts which are not sold or recommended by the manufacturer. This could cause fires, electric shock or other injuries.
- Any DAS system or Fiber BDA will generate radio (RF) signals and continuously emit RF energy. Avoid prolonged exposure to the antennas. SOLiD recommends maintaining a 3-foot minimum clearance from the antenna while the system is operating.
- Do not operate this unit on or close to flammable materials, as the unit may reach high temperatures due to power dissipation.
- Do not use any solvents, chemicals, or cleaning solutions containing alcohol, ammonia, or abrasives on the DAS equipment. Alcohol may be used to clean fiber optic cabling ends and connectors.
- To prevent electrical shock, switch the main power supply off prior to working with the DAS System or Fiber BDA. Never install or use electrical equipment in a wet location or during a lightning storm.
- Do not look into the ends of any optical fiber or directly into the optical transceiver of any digital unit. Use an optical spectrum analyzer to verify active fibers. Place a protective cap over any radiating transceiver or optical fiber connector to avoid the potential of radiation exposure.
- Allow sufficient fiber length to permit routing without severe bends.
- For pluggable equipment, make sure to install the socket outlet near the equipment so that it is easily accessible.
- A readily accessible disconnect device shall be incorporated external to the equipment.
- This power of this system shall be supplied through wiring installed in a normal building.

If powered directly from the mains distribution system, it shall be used additional protection, such as overvoltage protection device.

- Only 50 ohm rated antennas, cables and passive equipment shall be used with this remote. Any equipment attached to this device not meeting this standard may cause degradation and unwanted signals in the bi-directional system. All components connected to this device must operate in the frequency range of this device.

- Only 50 ohm rated antennas, cables and passive components operating from 150 - 3 GHz shall be used with this device.

- The following notice: "The Manufacturer's rated output power of this equipment is for single carrier operation. For situations when multiple carrier signals are present, the rating would have to be reduced by 3.5 dB, especially where the output signal is re-radiated and can cause interference to adjacent band users. This power reduction is to be by means of input power or gain reduction and not by an attenuator at the output of the device."

- The head end unit must always be connected to the Base Station using a direct cabled connection. This system has not been approved for use with a wireless connection via server antenna to the base station.

- Access can only be gained by SERVICE PERSONS or by USERS who have been instructed about the reasons for the restrictions applied to the location and about any precautions that shall be taken; and

- Access is through the use of a TOOL or lock and key, or other means of security, and is on trolled by the authority responsible for the location.

- Signal booster warning label message should include

**WARNING.** This is **NOT** a **CONSUMER** device. It is designed for installation by **FCC LICENSEES** and **QUALIFIED INSTALLERS**. You **MUST** have an **FCC LICENSE** or express consent of an FCC Licensee to operate this device. Unauthorized use may result in significant forfeiture penalties, including penalties in excess of \$100,000 for each continuing violation.

- Certification

- FCC: This equipment complies with the applicable sections of Title 47 CFR Parts 15,22,24,27 and 90(Class B)

- UL/CUL: This equipment complies with UL and CUL 1950-1 Standard for safety for information technology equipment, including electrical business equipment
- FDA/CDRH: This equipment uses a Class 1 LASER according to FDA/CDRH Rules. This product conforms to all applicable standards of 21 CFR Chapter 1, Subchapter J, Part 1040



# ***Section2***

## **System Overview**

---

**2.1 Purpose**

**2.2 Alliance 2W**

## 2.1 Purpose

Alliance 2W is a coverage system for in-building services delivering voice and data in high quality and for seamlessly.

As a distributed antenna system, it provides analog and digital phone systems that are served in multiple bands through one antenna.

The system covers general public institutions and private facilities.

- Shopping malls
- Hotels
- Campus areas
- Airports
- Clinics
- Subways
- Multi-use stadiums, convention centers, etc.

The system helps improve in-building radio environments in poor condition and make better poor RSSI and Ec/Io. By providing communication services at every corner of buildings, the system enables users to make a call at any site of buildings.

The system uses both analog (AMPS) and digital (TDMA, CDMA and WCDMA) methods.

The Alliance 2W system supports communication standards and public interface protocols in worldwide use.

- Frequencies: VHF,UHF, 700MHz, 800MHz,850MHz 900MHz,1900MHz,2100MHz, etc.
- Voice protocols: AMPS,TDMA, CDMA,GSM,IDEN, etc.
- Data protocols: EDGE,GPRS,WCDMA,CDMA2000,Paging, etc.

Alliance 2W is in modular structure per frequency. To provide desired frequency in a building, all you need to do is to insert a corresponding frequency module into each unit. As it delivers multiple signals with one optical cable, the system, in one-body type, does not require additional facilities whenever new frequency is added.

The system is featured with the following:

- Flexibility & Scalability
  - Support fiber-optic ports up to 39
  - Clustering multiple-buildings (campus) as one coverage
- Modular structures
  - Modular frequency upgrade
  - Plug-in type module
- Multi-Band, Multi Operator

- Signals with a plurality of service provider transmit simultaneously
- Support multi-operator in a band
- Low OPEX / CAPEX
  - Compact design
  - Upgradable design
  - Easy installation and maintenance
  - Web Based SNMP or GSM Modem or UDP support (Optional)

## **2.2 Alliance 2W**

L2ROU receives TX optical signals from ODU or OEU and converts them into RF signals. The converted RF signals are amplified through High Power Amp in a corresponding L2RDU, combined with Multiplexer module and then radiated to the antenna port.

When receiving RX signals through the antenna port, this unit filters out-of-band signals in a corresponding L2RDU and sends the results to Remote Optic Module to make electronic-optical conversion of them. After converted, the signals are sent to a upper device of ODU or OEU. L2ROU can be equipped with up to three L2RDUs (Remote Drive Unit) and the module is composed of maximal Dual Band.

### 2.3 Dimension

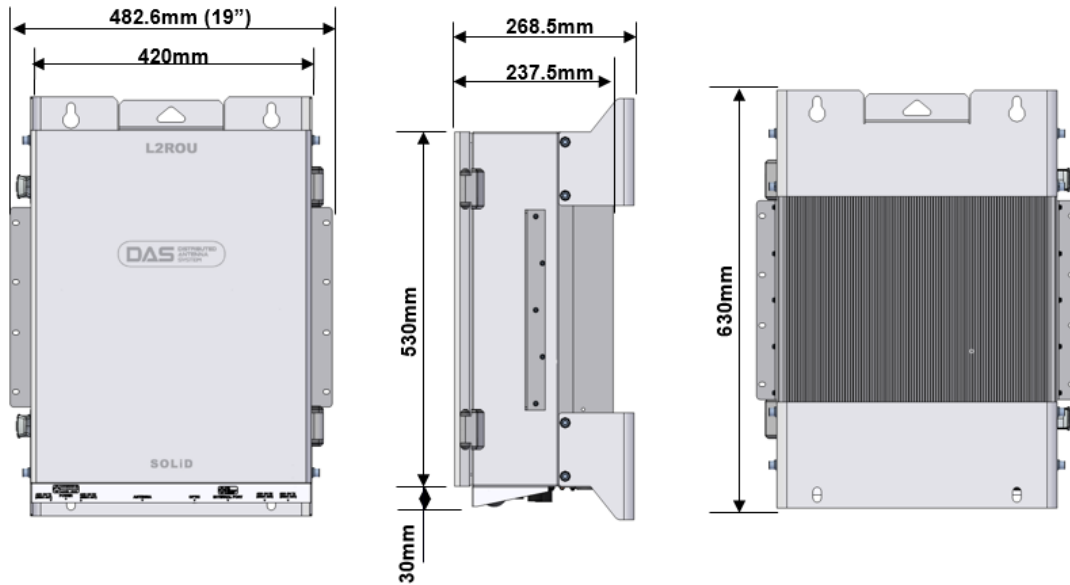

Figure 3.1 – L2ROU Outer Look

L2ROU is designed in a cabinet, and provides the following functions and features.

Item	Spec.	Remark
Size(mm)	482.6(19") x 268.5 x560,	Including Bracket
Weight	35.45 Kg	Full Load
Power consumption	235 W	
Operating Temperature	-10 to +50°C	Ambient Temperature

# ***Section3***

## **System Installation**

---

### **3.1 L2ROU Installation**

#### **3.1.1 L2ROU Enclosure installation**

L2ROU is designed to be water- and dirt-proof. The unit has the structure of One-Body enclosure.

It satisfies water-proof and quake-proof standards equivalent of NEMA4.

L2ROU can be mounted into either of a 19" Standard Rack or on a Wall.

Basically, L2ROU has both of a Wall Mount Bracket and a Rack Mount Bracket.

Depending on the use of the Rack Mount Bracket, the bracket can be removed.

The following shows dimension of the fixing point for the Wall Mount Bracket.

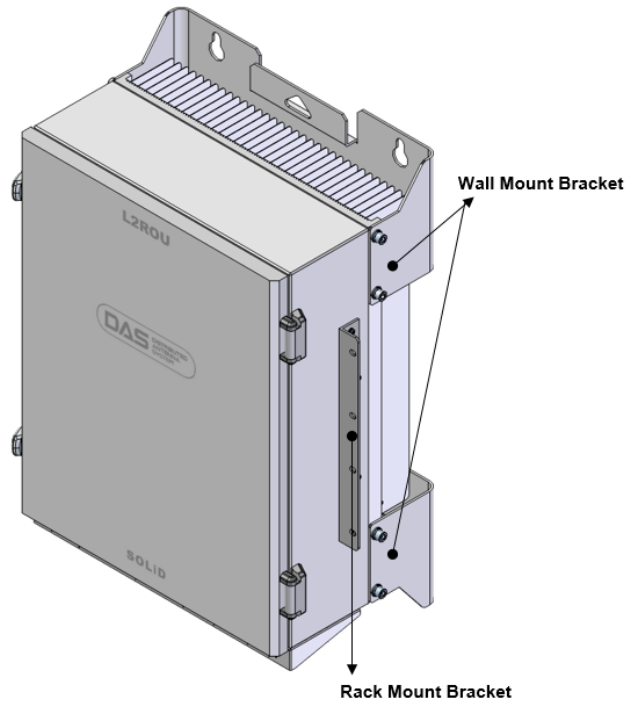

**Figure 3.2 – How to install L2ROU**

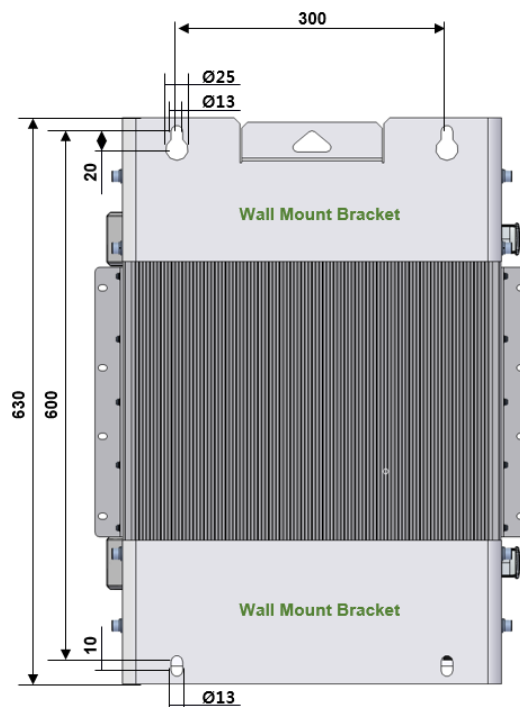

**Figure 3.3 – Dimension used to install L2ROU on the WALL**

## L2ROU Wall Mount Installation

Turn M12 Fixing Screws by half on the wall and fully fix the screw with a Wall Mount Bracket on it.

For convenience, the Wall Mount Bracket has fixing holes to let you easily mount an enclosure.

Turn the M5 Wrench Bolt by half at each side of the Heatsink of the enclosure.

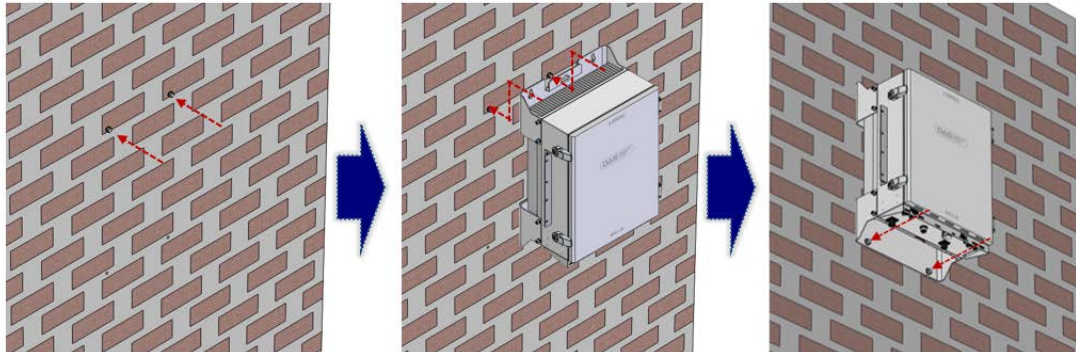

First, install 2 of M12 mounting bolts roughly half way on the enclosure and install enclosure over the bolts and secure tightly. Second, install 2 of M12 mounting bolts under the enclosure and secure tightly.

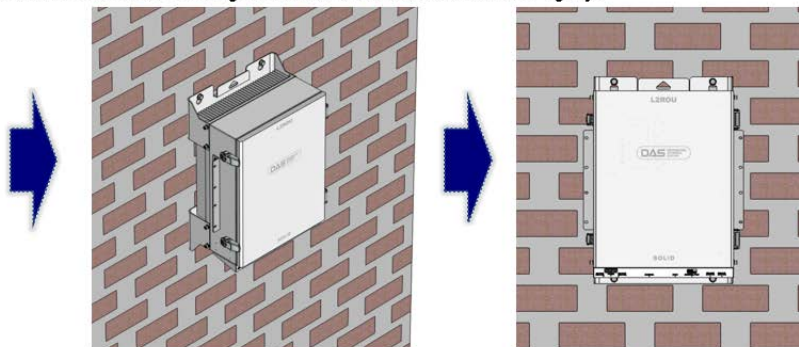

Put the enclosure with the M5 Wrench Bolt fixed on the fixing groove and fix the M5 Wrench Bolts into the remaining fixing holes.

In this case, you will use 12 M5 Wrench Bolts in total except bolts used for the fixing groove.

## L2ROU Rack Mount Installation

Like other units, L2ROU is designed to be inserted into a rack. The unit occupies around 13U of space except cable connection.

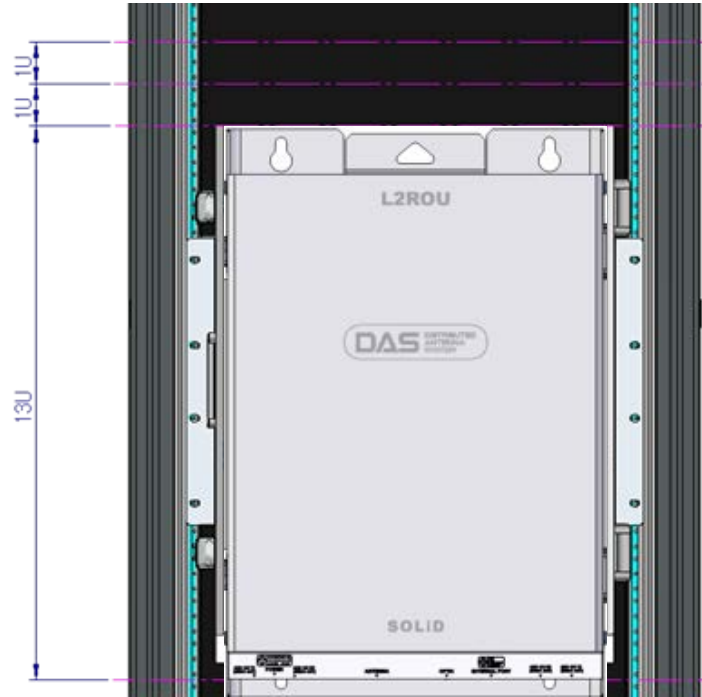

## L2ROU component

L2ROU has the following components:

No.	Unit	Description	Remark
Common Part	Enclosure	Including Rack & Wall cradle	1EA
	RCPU	-	1EA
	R_OPTIC	With SC/ACP adaptor	1EA
	RPSU	Alternative DC-48V or AC 120V	1EA
	Mux (Combine Unit)	-	1EA
	Power Cable	- MS Connector with 3 hole to AC 120 plug(AC) - MS Connector with 2 lug termination(DC)	



Optional Part	L2RDU+BPF	1900P_AWS13, 8085_700FB, 2500_60TDD 2300_WCS (L2RDU)	Up to 3EA to be inserted
	Dry contact Relay Sub board	Used to connect L2ROU to external alarm unit	

Basically, the common part of L2ROU should have an enclosure and it is equipped with RCPU to inquire and control state of each module, R\_OPTIC to make both of electronic-optical and optical-electronic conversions, RPSU to supply power for L2ROU and a Multi-Plexer to help share multiple TX/RX signals through one antenna. It should have Power Cable for external rectifier or to supply required power.

In addition, L2RDU can be inserted and removed to provide service for desired band (Optional).

### 3.1.2 L2ROU Power Cabling

L2ROU supports both of DC-48V and AC120V of input power.

Model Name	RPSU Type	Remark
L2ROU_AC	AC POWER SUPPLY	AC 120V
L2ROU_DC	DC POWER SUPPLY	DC-48V

As RPSU for DC-48 and RPSU for AC120V are separated from each other, you need to select one of them in case of purchase order.

RPSU for DC -48V and RSPU for AC 120V have the same configuration and capacity while each of the units uses different input voltage from each other.

The following figure shows configuration of RPSUs for DC -48V and AC 120V.



MC Connector numbering	Lug Naming		RPSU Terminal naming		Remark
	AC	DC	AC	DC	
A	AC_H	-48V	AC-H	-48V	
B	AC_N	GND	AC-N	IN_GND	
C	GND	DC NC	FG	FG	



Check if the connection is the same as one seen in the table above and make sure to turn the power ON.

Model Name	PSU Type	Remark
L2ROU_AC	AC POWER SUPPLY	AC 120V
L2ROU_DC	DC POWER SUPPLY	DC-48V

### 3.1.3 Optical Cabling

L2ROU makes optical-electronic conversion of TX signals from upper ODU and OEU and makes electronic- optical conversion of RX signals. L2ROU has one optical module in it. As WDM is installed in the R\_OPTIC module, two pieces of wavelength (TX:1310nm, RX:1550nm) can be sent/received with one optical core at the same time. L2ROU has SC/APC of optical adaptor type. For optical adaptor, SC/APC type can be used. To prevent the optical access part from being marred with dirt, it should be covered with a cap during move. When devices are connected through optical cables, you need to clear them using alcohol to remove dirt.

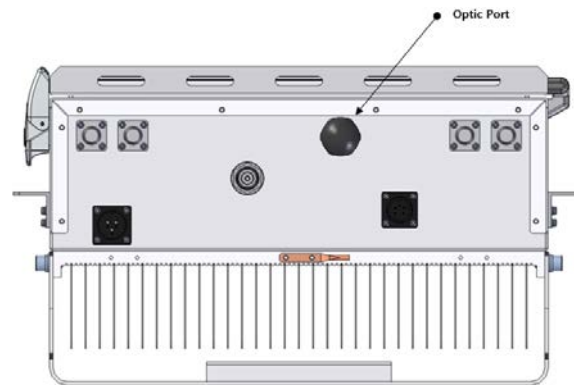

Optical cables should be inserted into Optic Port outside of L2ROU. Using an optical slack devices in L2ROU, you need to coil around one or two roll of cables to be connected with the optical adaptor of ROPTIC.

At this time, curvature of the optical cable should be at least  $10\varnothing$  to prevent insertion loss from being increased.

Through GUI, check if PD value of ROPTIC is in a tolerable range (+4~-1dBm).

### 3.1.4 GND Terminal Connection

L2ROU has one GND terminal port where is on bottom side, like below

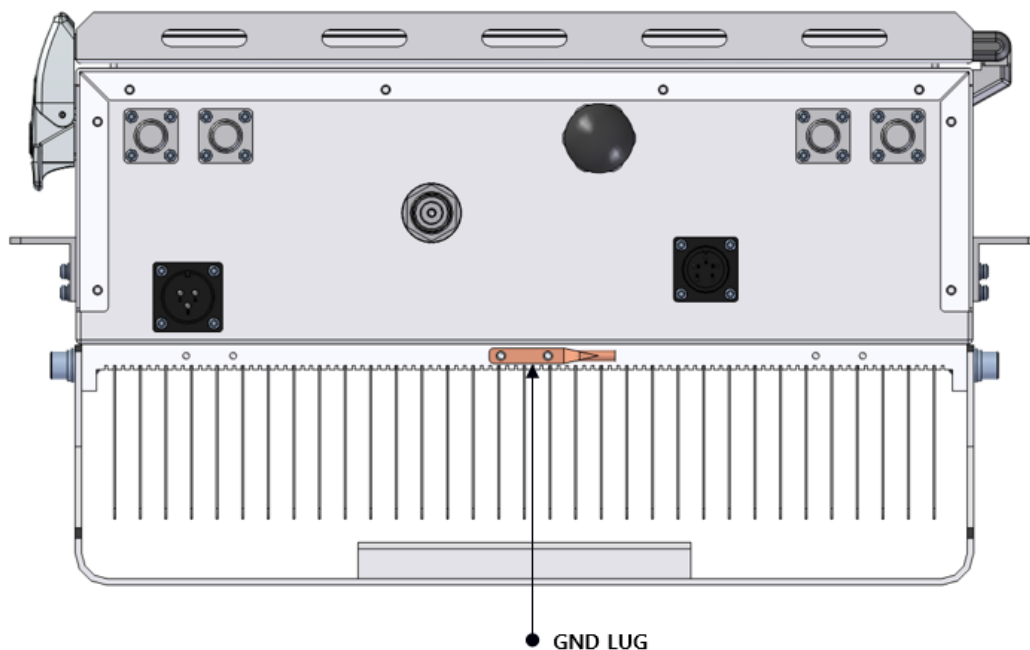

- Take off the GND terminal port from enclosure and connect to ground cable, then fix it the position of enclosure again

- The opposite end of the ground cable should connect to the communication GND of building

### 3.1.5 Coaxial cable and Antenna Connection

- The coaxial cables which are connected to antenna distributed network connect to antenna port of L2ROU. Before connection, check the VSWR value of coaxial cable whether it is within specification using SITEMASTER .
- At this time, check if the Return loss have above 15dB or VSWR have below 1.5
- The part of antenna connection fasten to port not to be loosed and not to be injected the dusty and insects
- The antenna connected to L2ROU is only serviced in inbuilding

### 3.1.6 Insertion of L2RDU

L2ROU has slots to enable up to three L2RDU modules to be inserted into the unit.

You can insert a L2RDU into any slot. It is not possible to provide services with a L2RDU module alone; you need to connect the module with Cavity BPF in any case.

The table below shows types of L2RDU and CAVITY BPF:

No	Unit naming	Cavity BPF	RF CABLE
1	L2RDU 8085_700FB(2W)	-	TX CABLE 1EA RX CABLE 1EA
2	L2RDU 1900P_AWS13(2W)	-	TX CABLE 1EA RX CABLE 1EA
3	L2RDU 2500_60TDD	2.5TDD BPF	TRX CABLE 1EA (Common)
4	L2RDU 2300_WCS	2300WCS BPF	TRX CABLE 1EA (Common)

### 3.1.7 L2RDU Specifications Per band

Standard	Unit naming	Description	Frequency range	
			TX(MHz)	RX(MHz)
LTE	700FB	Long Term Evolution	729 to 756	699 to 716 777 to 787
iDEN + Cellular	8085	Public safety Cellular	862 to 894	817 to 849
PCS	1900P	PCS	1930 to 1995	1850 to 1915
AWS-1 + AWS-3	AWS13	AWS	2110 to 2180	1710 to 1780
WCS	2300_WCS	WCS	2350 to 2360	2305 to 2315
TDD LTE	2500_60TDD	TDD	2497.8~2687.4	2497.8~2687.4

### 700MHz Long Term Evolution

Parameters	Typical		Remarks
	TX	RX	
Bandwidth	27MHz	27MHz	
Output power	+33dBm	+0dBm	Total
System Gain	53dB	50dB	
input and output impedances	50 ohm	50 ohm	

### 800MHz+850MHz Public safety & Cellular

Parameters	Typical		Remarks
	TX	RX	
Bandwidth	32MHz	32MHz	
Output power	+33dBm	+0dBm	Total
System Gain	53dB	50dB	
input and output impedances	50 ohm	50 ohm	

### 1900MHz PCS

Parameters	Typical		Remarks
	TX	RX	
Bandwidth	65MHz	65MHz	
Output power	+33dBm	+0dBm	Total
System Gain	53dB	50dB	
input and output impedances	50 ohm	50 ohm	

### 1700MHz&2100MHz AWS-1 + AWS-3

Parameters	Typical		Remarks
	TX	RX	
Bandwidth	70MHz	70MHz	
Output power	+33dBm	+0dBm	Total
System Gain	53dB	50dB	
input and output impedances	50 ohm	50 ohm	

### 2300MHz 2300\_WCS

Parameters	Typical		Remarks
	TX	RX	
Bandwidth	10MHz	10MHz	
Output power	+33 dBm	+0dBm	Total
System Gain	52dB	30dB	
input and output impedances	50 ohm	50 ohm	

### 2500MHz 2.5TDD

Parameters	Typical		Remarks
	TX	RX	
Bandwidth	189.6MHz	189.6MHz	
Output power	+32.5 dBm	-20dBm	@ RDU Port
System Gain	52dB	30dB	
input and output impedances	50 ohm	50 ohm	



### **RF Radiation Exposure for FCC**

This equipment complies with RF radiation exposure limits set forth for an uncontrolled environment. This transmitter must not be co-located or operating in conjunction with any other antenna or transmitter. RF exposure will be addressed at time of installation and the use of higher gain antennas may require larger separation distances.

### **Part 27.50 and SRSP**

Antennas must be installed in accordance with FCC 27.50 and SRSP 518. With 17dBi gain antennas the height of the antenna above average terrain (HAAT) must not exceed 2500 m. For different gain antennas refer to the relevant rules.

### **FCC notice**

- Use of unauthorized antennas, cables, and/or coupling devices not conforming with ERP/EIRP and/or indoor-only restrictions is prohibited.
  
- Home/ personal use are prohibited.

### **RSS-GEN, Sec. 7.1.2 – (transmitters)**

Under Industry Canada regulations, this radio transmitter may only operate using an antenna of a type and maximum (or lesser) gain approved for the transmitter by Industry Canada. To reduce potential radio interference to other users, the antenna type and its gain should be so chosen that the equivalent isotropically radiated power (e.i.r.p.) is not more than that necessary for successful communication.

*Conformément à la réglementation d'Industrie Canada, le présent émetteur radio peut fonctionner avec une antenne d'un type et d'un gain maximal (ou inférieur) approuvé pour l'émetteur par Industrie Canada. Dans le but de réduire les risques de brouillage radioélectrique à l'intention des autres utilisateurs, il faut choisir le type d'antenne et son gain de sorte que la puissance isotrope rayonnée équivalente (p.i.r.e.) ne dépasse pas l'intensité nécessaire à l'établissement d'une communication satisfaisante.*

### **RSS-GEN, Sec. 7.1.2 – (detachable antennas)**

This radio transmitter (identify the device by certification number, or model number if Category II) has been approved by Industry Canada to operate with the antenna types listed below with the maximum permissible gain and required antenna impedance for each antenna type indicated. Antenna types not included in this list, having a gain greater than the maximum gain indicated for that type, are strictly prohibited for use with this device.

*Le présent émetteur radio (identifier le dispositif par son numéro de certification ou son numéro de modèle s'il fait partie du matériel de catégorie I) a été approuvé par Industrie Canada pour fonctionner avec les types d'antenne énumérés ci-dessous et ayant un gain admissible maximal et l'impédance requise pour chaque type d'antenne. Les types d'antenne non inclus dans cette liste, ou dont le gain est supérieur au gain maximal indiqué, sont strictement interdits pour l'exploitation de l'émetteur.*

### **RF Radiation Exposure**

This equipment complies with RF radiation exposure limits set forth for an uncontrolled environment. This equipment should be installed and operated with a minimum distance of 200 cm with 7dBi antenna gain or 600 cm with 17dBi antenna gain between the radiator and your body. This transmitter must not be co-located or operating in conjunction with any other antenna

or transmitter. RF exposure will be addressed at time of installation and the use of higher gain antennas may require larger separation distances.

**RSS-102 RF Exposure**

*L'antenne (ou les antennes) doit être installée de façon à maintenir à tout instant une distance minimum de au moins 200 cm avec le gain d'antenne 7dBi ou 600 cm avec 17dBi gain d'antenne entre la source de radiation (l'antenne) et toute personne physique. Cet appareil ne doit pas être installé ou utilisé en conjonction avec une autre antenne ou émetteur.*