

T800 EFT-POS

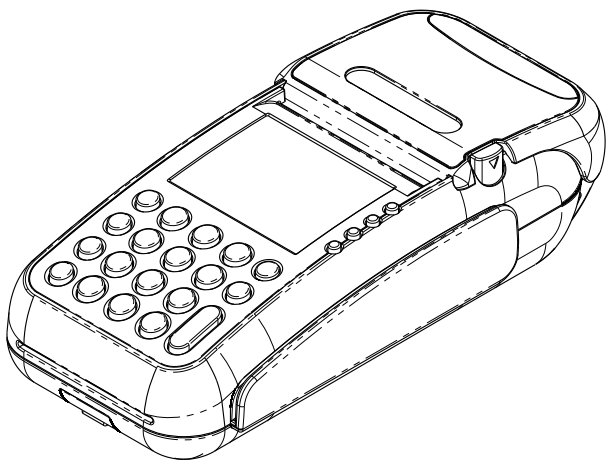

Installation Guide

Version 1.0



SPECTRA Technologies
ISO9001 : 2008
20002812 QM08



SPECTRA Technologies
ISO14001 : 2004
20002812 UM

Table of Content

1. Layout & Function Descriptions of T800	2
1.1 Main Unit & Accessories.....	2
1.2 Features at a Glance.....	3
1.3 Installation of SIM, SAM & Micro-SD Card.....	4
1.4 Battery Installation.....	4
1.5 Paper Feeding Procedure.....	5
1.6 Installation of Desktop Stand.....	6
2. How to Operate	7
2.1 Turn On/ Off Procedure.....	7
2.2 Swipe Card & Insert Card.....	7
3. Rechargeable Battery Safety Guideline	8
3.1 Prohibition.....	8
3.2 Battery Operation & Charging Guideline.....	8
3.3 Terminal and Battery Storage Guideline.....	9
3.4 Accident Handling.....	9
3.5 Battery Disposal.....	9
4. Safety & Maintenance	10
4.1 Basic Safety Practice.....	10
4.2 Safety Warning.....	10
4.3 Location for Installation.....	11
4.4 Maintenance.....	11
4.5 Trouble Shooting.....	12
4.6 Caution.....	13
5. Other Information	14

1 Layout & Function Descriptions of T800

1.1 Main Unit & Accessories

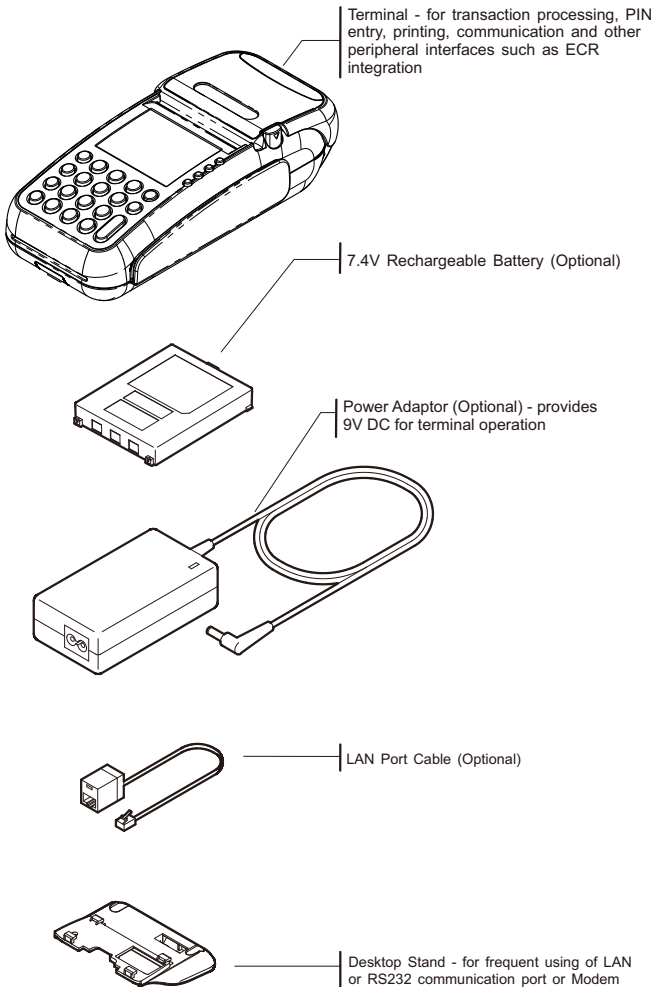

1.2 Features at a Glance

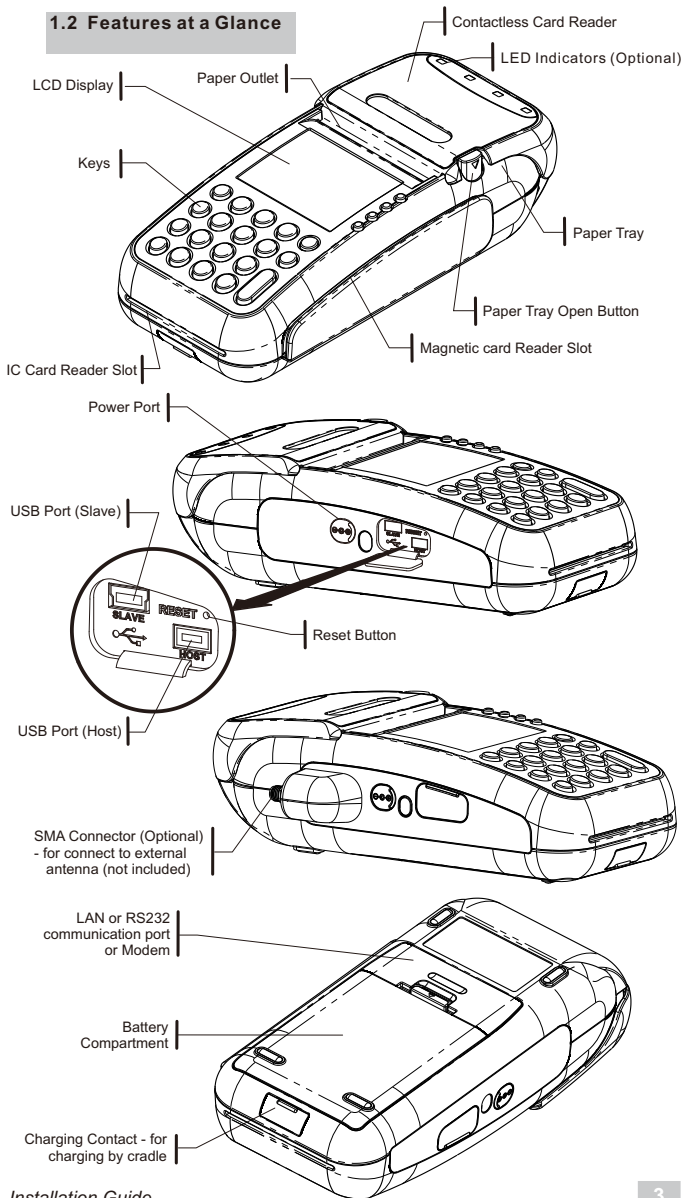

1.3 Installation of SIM, SAM & Micro-SD Card

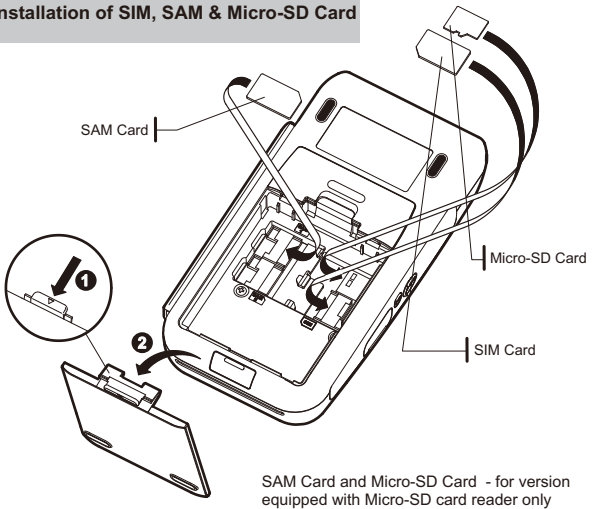

1.4 Battery Installation

for version equipped with battery pack only

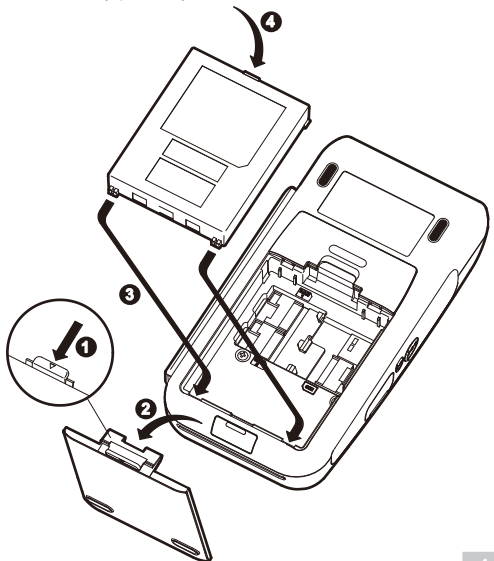

1.5 Paper Feeding Procedure

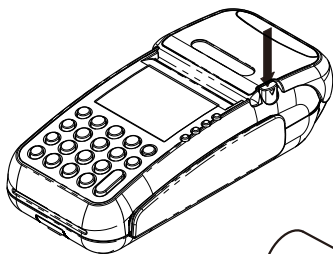

- 1** Press the button to open the paper cover

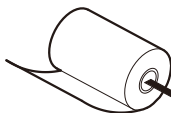

Place the paper roll into the tray as shown

2

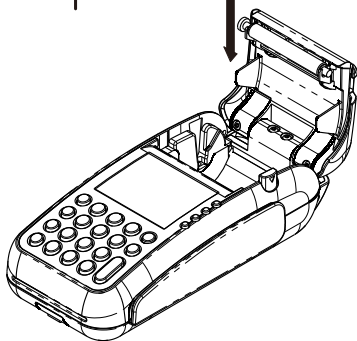

- 3** Close the paper cover

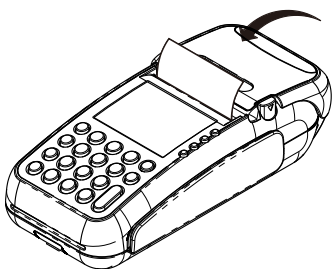

Paper roll size

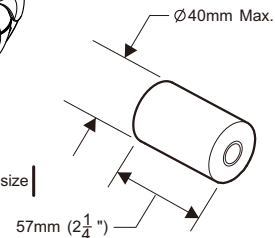

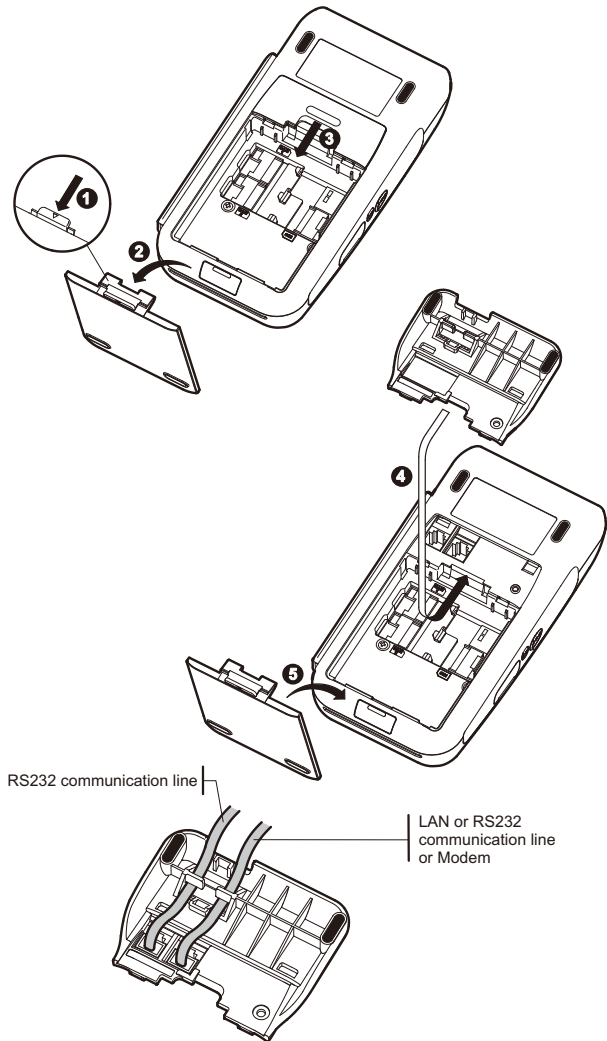

1.6 Installation of Desktop Stand

for version equipped with desktop stand only



2 How to Operate

2.1 Turn On/ Off Procedure

- If the terminal is equipped with charging battery during first time use, please connect the power adaptor and charge the battery for 3 hours.
- On - Power is on whenever plugged. If the terminal is unplugged, press the  key for several seconds to turn on the terminal. When the terminal displays "PLEASE SWIPE CARD", it is ready for operation.
- Off - Disconnect the power adaptor. Keep on pressing the  key for several seconds to turn off the terminal.

2.2 Swipe Card & Insert Card

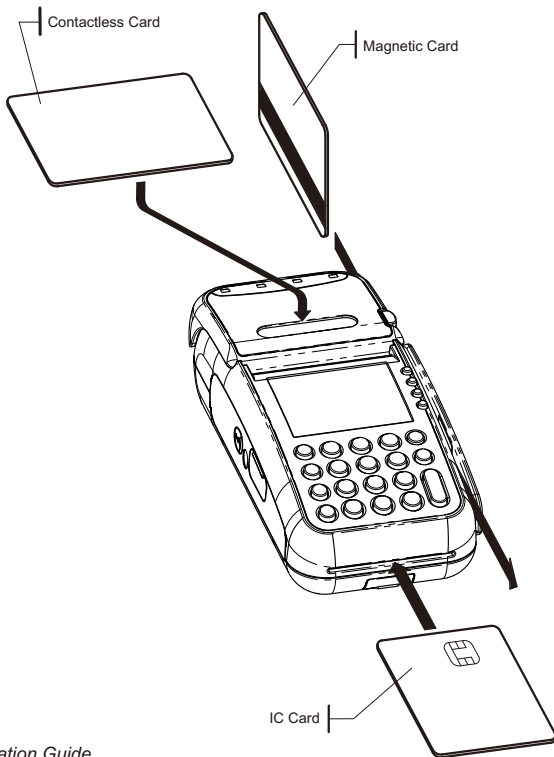

3 Rechargeable Battery Safety Guideline

3.1 Prohibition: Improper handling of the Li-Polymer battery is hazardous, the following forbidden activities must be avoided:

- DO NOT use NON-SPECTRA provided battery in SPECTRA POS Terminal
- DO NOT use a charger that is not specifically designed to charge Lithium Polymer Battery
- DO NOT operate the terminal, charge up or store the battery under high temperature (under direct sunlight or inside a roasting vehicle) or close to heat source (fire, heater)
- DO NOT store the battery in the external charger. After charging up, the battery should be removed, even though power is disconnected
- DO NOT use damaged battery, e.g. Swelled, case broken, strange odor and chemical leakage
- DO NOT knock, crash or press the battery
- DO NOT submerge the battery into water
- DO NOT heat the battery or dispose in fire
- DO NOT solder the battery
- DO NOT disassemble the battery
- DO NOT short or puncture the battery

3.2 Battery Operation & Charging Guideline

- The best temperature for battery operation is 0°C~ 45°C. DO NOT place the terminal in hot space or poor ventilated space. Ensure good ventilation for cooling
- DO NOT leave battery un-attended when charging. You should closely monitor the charging process & react to potential problem should they occur
- Do always check that batteries are physically and electrically undamaged before charge or discharge
- Battery charging must be kept away from inflammable material and on a non conductive and nonflammable stable surface by:
 - > Terminal built-in charger: install battery to the terminal, then apply power.
 - > SPECTRA supplied external charger
- When new terminal is received, please charge the battery fully up
- If the battery gauge indicates battery low, charge up the battery at once
- Battery always self-discharges. Long period of discharging will deteriorate the capacity and life of the battery. Please re-charge the battery weekly for normal operation

3.3 Terminal and Battery Storage Guideline

- If the battery will not be used for a long period, please charge it to only 50% of the battery capacity (battery indicator displays half full, 2 units); remove it from the terminal and store in a cool place. This can minimize the life deterioration caused by self-discharge
- DO NOT store bare battery together with metal, avoid humid and hot storage
- During storage period, please recharge the battery once every 3 months

3.4 Accident Handling

- During charging, if the battery or the charger exhibits any abnormality such as overheat, fuming, swelling & chemical leakage, disconnect power immediately, remove the battery from the charger, put it in a safe place and advise the supplier
- Li-Polymer Battery does not contain liquid electrolyte. Just in case human body touches the electrolyte, rinse with water and seek medical advice immediately
- Batteries having electrolyte leakage or chemical odor must be distant from fire source to prevent explosion
- If accidentally short the battery, put it in a non-conductive container and keep it away from flammable objects

3.5 Battery Disposal

- Protect your lovely Planet, please dispose the old batteries according to Government regulations

4 Safety & Maintenance

4.1 Basic Safety Practice

While using terminal and its accessories, please follow the safety instruction to avoid fire, electric shock and personal injury.

- Read this instruction in detail
- Disconnect the power and accessories before cleaning, use dry flannelette and soft brush for cleaning
- Do not put the terminal near water
- Do not spray any liquid onto the terminal
- For desktop purpose, put the terminal on stable platform to avoid damage by drop
- Keep the terminal away from high temperature and poor ventilation area
- Ensure electricity supply is safe and stable
- To avoid electric shock, do not disassemble the terminal by yourself. Send it to agency for repairing if necessary
- Do not use terminal and its accessories during explosive gas leakage
- For modem version, do not install telephone line during lightning
- If possible, disconnect telephone line before storming to avoid electric shock
- For the following cases, disconnect power, other accessories and send for repairing,
 - ~ Damage on power cable or plug
 - ~ Liquid get into terminal
 - ~ Terminal gets wet in raining
 - ~ Still abnormal function after following all the instruction mentioned
 - ~ Terminal broken
 - ~ Terminal obvious abnormal

4.2 Safety Warning

- Using the provided terminal power adaptor to power the terminal
- During using wireless communication, keep human body at least 1.5cm apart from the terminal. Keep the terminal away from other antenna or wireless device.
- Do not touch the thermal printer head and paper cutter

4.3 Location for Installation

- Should be safe and convenient for operators and users
- Should be placed on stable working platform during desktop operation for ease of power and accessories connection
- Good ventilation and should have 10cm space around the terminal
- DO NOT expose terminal in following environment
 - ~ Near electrical appliance with high frequency EM wave such as air conditioner, electric fan, motor, neon sign etc.
 - ~ Liquid container such as water trough, sink, pond etc.
 - ~ High temperature or humidity place
 - ~ High containing of VOC, salty and dusty area
 - ~ Sunlight or high thermal radiation area
 - ~ Near demagnetizing system and magnetic security system

4.4 Maintenance

Terminal has been designed to provide stable service for users with less maintenance.

In order to ensure best performance, we suggested the followings.

- Avoid exposing in sunlight, high temperature, high humidity and dusty area
- Keep in dry, clean and tidy environment
- Do not keep in extreme hot and cold place
- Do not disassemble the AC/DC power adaptor
- Do not impact and thrash the terminal heavily
- Do not disassemble the terminal (except opening the Battery Cover). Disassembling will erase all data and lead to abnormal running

Cleaning of terminal

- Use flannelette to remove dust on terminal
- Use mild alcohol to remove stubborn stains
- If possible, use low pressure blower to blow out dust on keypad
- Use flannelette or lens cleaning paper to clean the display

Printer Cleaning

- Disconnect power cable from the terminal
- Open paper cover, take out paper and roller
- Remove dust and paper scrap inside paper tray . Use low pressure blower to clean the paper tray if possible.
- Do not touch the thermal printer head and paper cutter during cleaning
- Put back paper and roller into paper tray
- Close the paper cover

Send for repairing

- If it is necessary to send back terminal for repairing, please contact agency, pack the terminal properly (use original packing material if possible) to avoid damage during transportation

4.5 Trouble Shooting

Terminal has been designed to provide stable service for users. However, there would be some minor problems during in use. Before sending back for repairing, users can try the following simple procedures to fix the problems themselves

Terminal not function

- 1, If it is powered by power adaptor, check whether the connection of power cord or power adaptor is connected properly
- 2, If it is powered by power adaptor, try to check whether the AC source is error free by plugging with other electrical appliance
- 3, If it is powered by power adaptor, try to replace the adaptor with another one
- 4, If it is powered by power adaptor, try to replace the electric power socket with another one
- 5, Try to adjust the LCD contrast
- 6, Contact agency if problem cannot be solved

Unsuccessful transaction

- 1, Try to use other magnetic card or IC card or contactless card for transaction
- 2, Check whether the way of swiping card or inserting card is correct
- 3, Check whether all wire ends are connected properly
- 4, Contact agency if problem cannot be solved

Malfunction on printer

- 1, If the terminal is powered by battery, check the battery level and charge the battery, replace new battery or else power the terminal by adaptor.
- 2, If it is powered by power adaptor, check whether the connection of power cord or power adaptor is connected properly
- 3, Open paper cover, check whether the paper is used up
- 4, Check whether the way of paper feeding is correct, please refer to section 1.5
- 5, The printer accepts thermal paper only, check whether the paper roll is the correct type, please refer to section 1.5
- 6, Check whether the paper is jammed or damaged. Try to open the paper cover and smooth the paper path.
- 7, Contact agency if problem cannot be solved

Malfunction on magnetic card reader

- 1, Check whether the way of card swiping is correct, speed is normal, please refer to section 2.2
- 2, Try to swipe in opposite direction
- 3, Try to use another card
- 4, Contact agency if problem cannot be solved

Malfunction on IC card reader

- 1, Check whether the way of card insertion is correct, please refer to section 2.2
- 2, Check whether the card is completely inserted
- 3, Try to use another card
- 4, Contact agency if problem cannot be solved

Malfunction on Contactless card reader

- 1, Check whether the position of card swiping is correct, please refer to section 2.2
- 2, Check whether the card is completely swiped on the contactless card reader
- 3, Try to use another card
- 4, Contact agency if problem cannot be solved

4.6 Caution

RISK OF EXPLOSION IF BATTERY IS REPLACED BY AN INCORRECT TYPE.

DISPOSE OF USED BATTERIES ACCORDING TO THE INSTRUCTIONS.

5 Other Information

Dimensions & Weight

Size: 185 (L) x 84 (W) x 56 (H) mm
(Without magnetic stripe card reader)

185 (L) x 88 (W) x 56 (H) mm
(With magnetic stripe card reader)

185 (L) x 105 (W) x 56 (H) mm
(With SMA connector)

Weight: 500g (Terminal with battery)

Operating environment

Temperature: 0°C - 45°C

Humidity: 0% - 85% (non-condense)

Power input

DC 9V, 3A

This device complies with part 15 of the FCC Rules. Operation is subject to the following two conditions:
(1) This device may not cause harmful interference, and (2) this device must accept any interference received, including interference that may cause undesired operation.

Any Changes or modifications not expressly approved by the party responsible for compliance could void the user's authority to operate the equipment.

Specific Absorption Rate (SAR) information:

This wireless phone meets the government's requirements for exposure to radio waves. The guidelines are based on standards that were developed by independent scientific organizations through periodic and thorough evaluation of scientific studies. The standards include a substantial safety margin designed to assure the safety of all persons regardless of age or health. FCC RF Exposure Information and

Statement The SAR limit of USA (FCC) is 1.6W/kg averaged over one gram of tissue. Device types: T800 (FCC ID: VWZT800W) has also been tested against this SAR limit. The highest SAR value reported under this standard during product certification for use when properly worn on the body is 1.07W/kg. This device was tested for typical body-worn operations with the back of the handset kept 1.5cm from the body. To maintain compliance with FCC RF exposure requirements, use accessories that maintain a 1.5cm separation distance between the user's body and the back of the handset. The use of belt clips holsters and similar accessories should not contain metallic components in its assembly. The use of accessories that do not satisfy these requirements may not comply with FCC RF exposure requirements, and should be avoided.

Body-worn Operation

Note: This equipment has been tested and found to comply with the limits for a Class A digital device, pursuant to part 15 of the FCC Rules. These limits are designed to provide reasonable protection against harmful interference when the equipment is operated in a commercial environment. This equipment generates, uses, and can radiate radio frequency energy and, if not installed and used in accordance with the instruction manual, may cause harmful interference to radio communications. Operation of this equipment in a residential area is likely to cause harmful interference in which case the user will be required to correct the interference at his own expense.

