

QUARQ

POWERFOR **SRAM**



Statement of Compliance for FCC and Industry Canada:

Quarq Technology / SRAM LLC.

Model#: 0808

FCC ID: C90-MERC1

IC: 1016A-MERC1

This equipment has been tested and found to comply with the limits for a Class B digital device, pursuant to Part 15 of the FCC Rules. These limits are designed to provide reasonable protection against harmful interference in a residential installation. This equipment generates uses and can radiate radio frequency energy and, if not installed and used in accordance with the instructions, may cause harmful interference to radio communications. However, there is no guarantee that interference will not occur in a particular installation.

Operation is subject to the following two conditions:

- 1 This device may not cause harmful interference, and
- 2 this device must accept any interference received, including interference that may cause undesired operation.

This product meets the applicable Industry Canada technical specifications.

Le présent matériel est conforme aux spécifications techniques applicables d'Industrie Canada.

The term "IC:" before the radio certification number only signifies that Industry Canada technical specifications were met.

Warning: Any changes or modifications not expressly approved by SRAM could void the user's authority to operate this equipment.

Statement of RoHS Compliance:

Quarq Technology / SRAM LLC. certifies that this product and its packaging are in compliance with European Union Directive 2002/95/EC on the Restriction of the Use of Certain Hazardous Substances in Electrical and Electronics Equipment, commonly known as RoHS.

ANT+(TM) Product Certification

This product is ANT+ certified and complies with the bicycle power ANT+ Device Profile. For a complete listing of ANT+ Certified Products and their specific interoperability, please visit www.thisisant.com.



This publication includes trademarks and registered trademarks of SRAM LLC designated by the symbols ™ and ®, respectively.

Product names used in this publication may be trademarks or registered trademarks of others.

SRAM LLC Warranty**Extent of Limited Warranty**

SRAM warrants its products to be free from defects in materials or workmanship for a period of two years after original purchase. This warranty only applies to the original owner and is not transferable. Claims under this warranty must be made through the retailer where the bicycle or the SRAM component was purchased. Original proof of purchase is required.

Local law

This warranty statement gives the customer specific legal rights. The customer may also have other rights which vary from state to state (USA), from province to province (Canada), and from country to country elsewhere in the world.

To the extent that this warranty statement is inconsistent with the local law, this warranty shall be deemed modified to be consistent with such law, under such local law, certain disclaimers and limitations of this warranty statement may apply to the customer. For example, some states in the United States of America, as well as some governments outside of the United States (including provinces in Canada) may:

- a. Preclude the disclaimers and limitations of this warranty statement from limiting the statutory rights of the consumer (e.g. United Kingdom).
- b. Otherwise restrict the ability of a manufacturer to enforce such disclaimers or limitations.

Limitations of Liability

To the extent allowed by local law, except for the obligations specifically set forth in this warranty statement, in no event shall SRAM or its third party suppliers be liable for direct, indirect, special, incidental, or consequential damages.

Limitations of Warranty

This warranty does not apply to products that have been incorrectly installed and/or adjusted according to the respective SRAM technical installation manual. The SRAM installation manuals can be found online at sram.com, rockshox.com, avidbike.com, truvatv.com, zipp.com, or quarq.com.

This warranty does not apply to damage to the product caused by a crash, impact, abuse of the product, non-compliance with manufacturers specifications of usage or any other circumstances in which the product has been subjected to forces or loads beyond its design.

This warranty does not apply when the product has been modified.

This warranty does not apply when the serial number or production code has been deliberately altered, defaced or removed.

This warranty does not apply to normal wear and tear. Wear and tear parts are subject to damage as a result of normal use, failure to service according to SRAM recommendations and/or riding or installation in conditions or applications other than recommended.

Wear and tear parts are identified as:

- Dust seals
- Bushings
- Air sealing o-rings
- Glide rings
- Rubber moving parts
- Foam rings
- Rear shock mounting hardware and main seals
- Upper tubes (stanchions)
- Stripped threads/bolts (aluminium, titanium, magnesium or steel)
- Brake sleeves
- Brake pads
- Chains
- Sprockets
- Cassettes
- Shifter and brake cables (inner and outer)
- Handlebar grips
- Shifter grips
- Jockey wheels
- Disc brake rotors
- Wheel braking surfaces
- Bottomout pads
- Bearings
- Bearing races
- Pawls
- Transmission gears
- Spokes
- Free hubs
- Aero bar pads
- Corrosion
- Tools
- Batteries

This warranty shall not cover damages caused by the use of parts of different manufacturers.

This warranty shall not cover damages caused by the use of parts that are not compatible, suitable and/or authorised by SRAM for use with SRAM components.

This warranty shall not cover damages resulting from commercial (rental) use.

TABLE OF CONTENTS

POWER METER ANATOMY	6
INSTALLATION	7
MAGNET INSTALLATION	7
BB CUP MOUNT INSTALLATION	8
CABLE GUIDE MOUNT INSTALLATION.....	9
ADHESIVE PUTTY INSTALLATION.....	10
CRANK INSTALLATION	11
SET UP	11
LED FUNCTIONALITY	11
PAIRING	12
ZEROING	12
CHAINRING INSTALLATION	14
MAINTENANCE AND CARE.....	15
BATTERY INFORMATION.....	15
BATTERY CARE.....	15
CLEANING	15
TROUBLESHOOTING.....	16

POWER METER ANATOMY

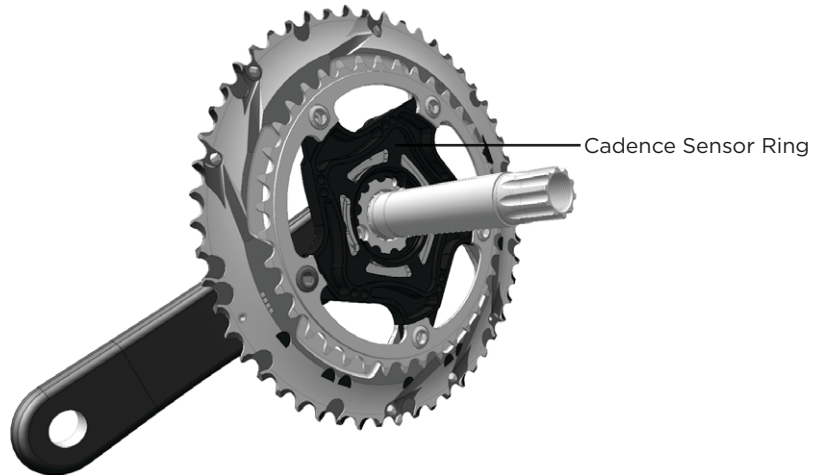
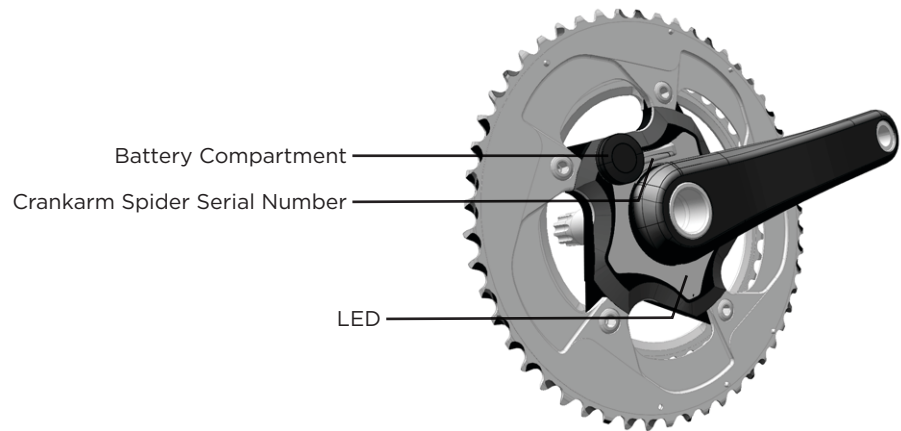

INSTALLATION

MAGNET INSTALLATION

The included magnet must be installed for the power meter to function. There are three ways to install the magnet: BB Cup Mount, Cable Guide Mount, and Adhesive Putty (only one type of mount can be used at a time). When properly installed, the magnet should be in line with the cadence sensors and within 2-8 mm of the sensors. If necessary, magnets may be stacked to achieve the proper distance to the sensor. Do not allow the magnet to contact the power meter.

It is easier to install the magnet when the cranks are not installed on the frame.

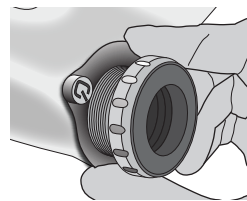

BB Cup Mount

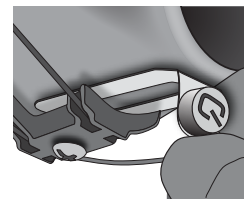

Cable Guide Mount

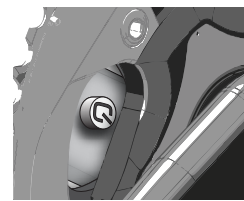

Adhesive Putty

BB CUP MOUNT INSTALLATION

The BB Cup Mount is only compatible with threaded bottom brackets. It does not work with frames that have bearings pressed into the bottom bracket (BB30, PF30, etc.). Frames using threaded bottom bracket adapters (ie. SRAM GXP30 BB Adapter) may use the BB Cup Mount if the mount is installed onto the threaded drive side bottom bracket cup.

1. If necessary, remove the existing cranks and bottom bracket.
2. Slide the BB Cup Mount over the threads of the drive side bearing cup with the magnet facing away from the frame.
3. Hold the magnet at the 9 o'clock position while the bottom bracket is tightened to the manufacturer's recommended torque.
4. Confirm the magnet is within 2-8 mm (1/16"-3/8") of the sensor.

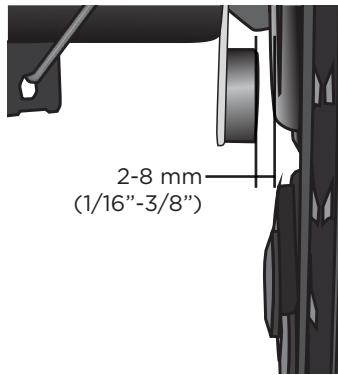
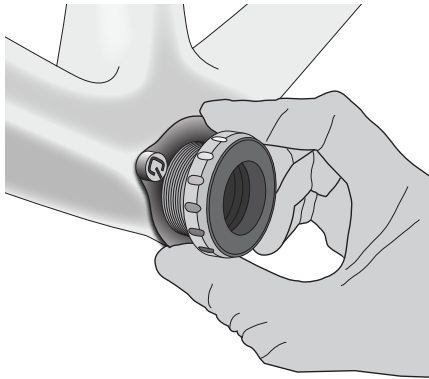

CABLE GUIDE MOUNT INSTALLATION

The Cable Guide Mount should only be used when the cable guide is fastened with a screw. If the cable guide is fastened with a rivet, use the Bottom Bracket Cup Mount or Adhesive Putty instead.

Installation Notes: Do not allow the magnet to contact the power meter. When properly installed, the magnet should be in line with the cadence sensors and within 2-8 mm (1/16"-3/8") of the sensors.

1. Remove the existing cranks.
2. Loosen the cable guide screw. It may be helpful to shift the front derailleur to the small chainring position, and the rear derailleur to the smallest cog. This will reduce the cable tension, and make it easier to slide the cable guide mount under the cable guide.
3. Slide the mount under the cable guide.
4. Reinstall the cranks.
5. Tighten the cable guide screw.
6. Confirm the magnet is within 2-8 mm (1/16"-3/8") of the sensor.

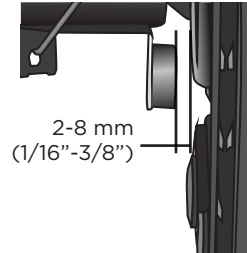
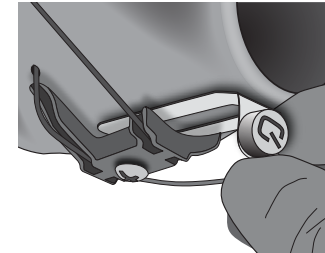
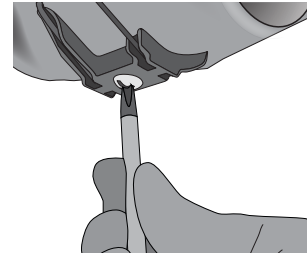

ADHESIVE PUTTY INSTALLATION

The included adhesive putty will permanently attach the magnet to your frame. Other **non-permanent** attachment options include: hot glue, some epoxies, electrical tape, or similar adhesives.

Installation Notes: Do not allow the magnet to contact the power meter. When properly installed, the magnet should be in line with the cadence sensors and within 2-8 mm (1/16"-3/8") of the sensors. Depending on your frame, you may need to stack 2-3 magnets to achieve this distance.

1. Remove the existing cranks.
2. Clean the frame with the included alcohol pad prior to attaching the magnet.
3. Knead both colors of adhesive putty with your fingers until you have one consistent color.
4. Place a 6 mm (1/4") diameter ball of putty on the back of the magnet, and then press the magnet onto the frame. The center of the magnet should be positioned between 30 mm and 38 mm (1 1/8"-1 1/2") from the center of the bottom bracket.
5. Use a toothpick to carefully remove any excess putty before it dries. The putty will set up in about 10 minutes, and will cure in 1 hour.
6. Reinstall the cranks.
7. Confirm the magnet is within 2-8 mm (1/16"-3/8") of the sensor.

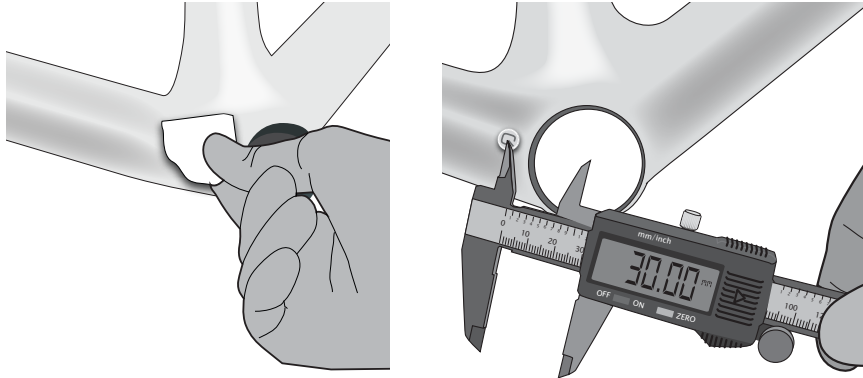

CRANK INSTALLATION

Install the crankset and bottom bracket assembly onto your bike according to the manufacturer's instructions.

Once the crankset has been installed, the power meter must not contact the frame or any other components. Please contact Quarq customer service with any frame compatibility questions. An updated list of compatible frames is available at Quarq.com.

SET UP

LED FUNCTIONALITY

The LED provides useful information about the operating condition of the power meter. See the 'Self-Test' in the Troubleshooting section for more LED information.

The LED will flash:

- twice when battery is inserted
- once when waking.
- once when finished zeroing (calibration)
- once when entering the sleep state.

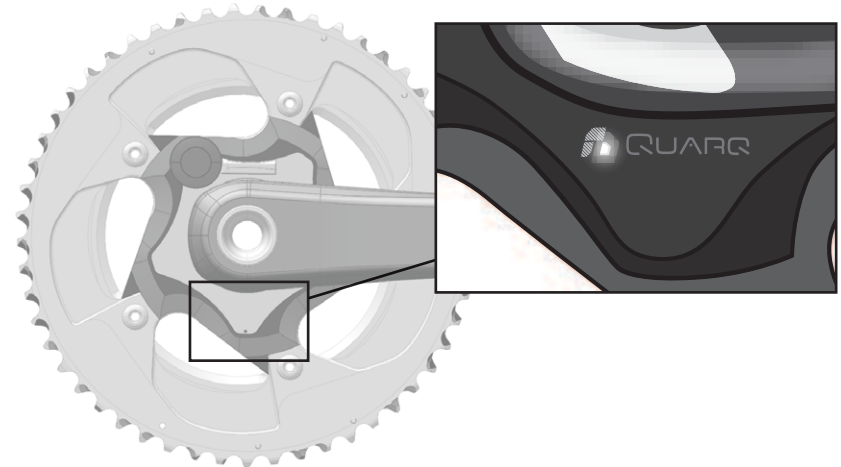

PAIRING

Before pairing your power meter to a computer, make sure you are at least 10 meters (30 feet) from any other ANT+™ device. This will keep you from accidentally pairing to another person's ANT+ device.

To pair the Quarq with an ANT+ computer, first spin the crank backwards 2-3 times to wake the power meter and begin broadcasting ANT+ messages. *The power meter will shut off after about 10 minutes of inactivity.*

Follow the pairing instructions specific to your ANT+ computer.

GARMIN® EDGE 800

To pair the power meter:

Click the Power button → tap the Dumbbell icon  → Rescan

“Power Meter Detected” will flash up on your screen when the units are paired.

GARMIN EDGE 500

To pair the power meter:

Menu → Settings → Bike Settings → Bike 1 → ANT+Power → Rescan

“Power Meter Detected” will flash up on your screen when the units are paired.

GARMIN FORERUNNER 310XT WATCH

Your watch must be in bike mode in order to pair and zero your power meter (press and hold the **Mode** button).

To pair the power meter:

Mode → Bike Settings → Bike 1 → Ant+Power → Restart Scan

“Power Meter Detected” will appear on your screen when the units are paired.

ZEROING

The power meter must be zeroed to compensate for environmental changes. The power meter can be zeroed two ways: **Auto Zero** and **Manual Zero**.

When to perform the Zero procedure

For best results, you should perform the **Manual Zero** procedure before you start each ride. The **Auto Zero** procedure can be performed instead of a **Manual Zero** or if your computer cannot send a “Calibrate” command; if the temperature changes greatly during your ride; or if you feel that you are getting inaccurate data.

Manual Zero

We recommend that the **Manual Zero** procedure be performed with the rider off of the bike.

The power meter may be zeroed manually by sending the “Calibrate” command from an ANT+™ compatible bike computer. The power meter will return the Zero Offset value (or “Current Calibration” on some computers) to the computer; however, not all ANT+ computers will display the value. The Zero Offset is typically between +/- 500. Some units will always have a Zero Offset value outside of this range without any impact on performance. What is more important is that the pre- and post-ride Zero Offset values are within 50 points of each other. If the pre- and post-ride Zero Offset values frequently vary by more than 50, or if day-to-day values vary widely, please call Quarq customer service.

When performing the **Manual Zero** procedure, put the drive side crank arm in the 6 o'clock position, keeping the cranks stationary with no force on the pedals. Follow the pairing instructions specific to your ANT+ computer to send the “Calibrate” command. **The LED will flash one time when zeroing is complete.**

GARMIN® EDGE 800

Click the Power button → tap the Dumbbell icon  → Calibrate

GARMIN EDGE 500

Menu → Settings → Bike Settings → Bike 1 → ANT+Power → Calibrate

GARMIN FORERUNNER 310XT WATCH

Mode → Bike Settings → Bike 1 → Ant+Power → Calibrate

Auto Zero

Spin the crank backwards for 4-5 complete revolutions. **The LED will long-blink one time when zeroing is complete.** The computer will not display the Zero Offset value. The **Auto Zero** procedure may be performed while coasting with the rider on the bike, stopped using one or both feet, or by hand with the rider off of the bike.

CHAINRING INSTALLATION

If you are replacing worn rings with a new pair of the same model, **OR REPLACING WITH SRAM RED TT CHAINRINGS**, re-calibration is not required. If you are replacing your chainrings with a different model or size, re-calibration is strongly recommended.

Visit Quarq.com for chainring compatibility tables, and calibration information. Your daily offset values will be different than those you have previously noted.

When installing chainrings you must align the chainring tabs so they are in line with the crankarm.

Tighten the chainring bolts according to the manufacturer's instruction.

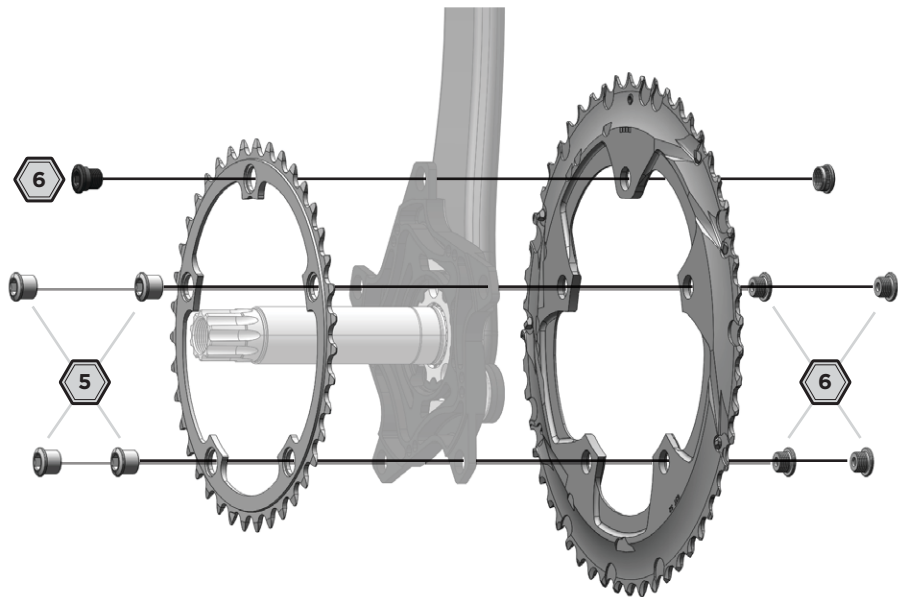

MAINTENANCE AND CARE

BATTERY INFORMATION

- The power meter is powered by a **CR2032** coin cell battery.
- The battery can be replaced without any special tools. To replace the battery, unthread the lid counter-clockwise. Do not use any tools to pry it open. The battery should be installed with the "+" facing out. Re-install and hand tighten the battery cover after the battery is replaced.
- The power meter automatically switches on when the crankarms are rotated, and shuts off after about 10 minutes of inactivity. Under normal operating conditions the battery will last for about **300** hours of riding.
- The power meter will send a warning when the battery is low. However, not all ANT+™ computers will display the message.
- The power meter retains its sensor ID throughout battery changes and will remain properly paired with your computer.

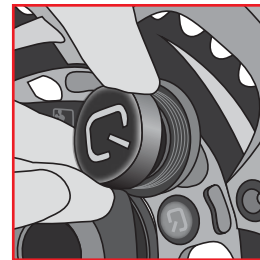

BATTERY CARE

- The battery must be installed correctly ("+" out) and have sufficient charge.
- **Periodically check the battery compartment to make sure the battery contact is** free of corrosion and moisture.

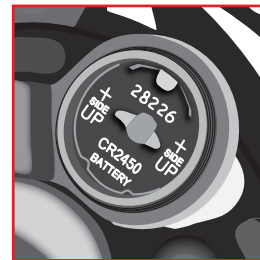

CLEANING

The power meter is very durable; however, periodic cleaning is recommended. Use a rag to wipe debris from the power meter, crankarms, magnet, and chainrings. Brush the power meter, crankarms, magnet, and chainrings with clean or soapy water, then rinse with clean water and let air dry. Do not use harsh chemicals and do not use a high-pressure washer.

TROUBLESHOOTING

Performing a Self-Test can quickly diagnose problems with the Power Meter. Perform a Self-Test by back-pedaling one or more times, and then observe the LED.

- **Zero blinks: Dead battery, or magnet not installed.**
- **1 long blink: Self check pass. Head unit paired.**
- **2 short blinks: Self check pass. No head unit paired.**
- **3 short blinks: Self check Fail. Reed switch Failure.**
- **4 short blinks: Self check Fail. Bad Strain Gauge.**

Power Meter does not pair with the computer

- Check the battery. The battery must be installed correctly (“+” out) and have sufficient charge. **Make sure the battery contact is free of corrosion.**
- Check the magnet position. **Confirm the magnet is within 2-8 mm (1/16”-3/8”) of the sensor.** The magnet should be installed according to the instructions on pages 8-10. Once the cadence sensors have been activated, the power meter will begin transmitting messages and is ready to be paired.
- Make sure the proper pairing technique has been followed for your bike computer. The pairing process will vary by manufacturer. Refer to your bike computer’s instruction manual.
- If you are using a Garmin® bike computer with ANT+™ heart rate enabled, calibration will often be faster when you are wearing the heart rate monitor/strap. Turn off the ANT+ HRM function if you are not using a heart rate strap.
- Check with Quarq for the recommended firmware version for your Garmin computer. Follow the instructions specific to your ANT+™ computer to check the installed firmware version.

GARMIN® EDGE 800

Menu → Settings → About Edge

GARMIN EDGE 500

Menu → Settings → About Edge

To view the menu, you must press and hold the **Menu** button until the menu pops up.

GARMIN FORERUNNER 310XT WATCH

Mode → Settings → About Forerunner

Cadence, but no power

- Check the magnet position. The magnet should be installed according to the instructions on pages **8-10**. Zero the power meter using Auto Zero or Manual Zero as described on pages **12-13**.
- Remove any separate cadence or speed sensors.

Unusually high or low power values

1. Perform the Manual Zero as described on page **13**.
 2. If the Manual Zero is well outside +/- 500, check pre- and post- ride Zero Offset values.
 3. If the pre- and post-ride Zero Offset values are greater than 50 points, it may be necessary to contact Customer Support. *Keeping a record of the Zero Offset values will be helpful when contacting Customer Support.*
- Remove third party cadence sensors. The Quarq delivers both power and cadence data to the bike computer.
 - Inspect and clean the chainrings and Quarq interface. Re-assemble according to the instructions on page **14**.

Manual Zero (Calibration) Fails

- When performing the Manual Zero procedure, make sure that the drive side crank arm is at the 6 o'clock position, there is no weight on the pedals, and the cranks are stationary.
- If you are using a Garmin® bike computer with ANT+™ heart rate enabled, calibration will often be faster when you are wearing the heart rate monitor/strap. Turn off the ANT+ HRM function if you are not using a heart rate strap.

Wireless Signal Disconnections

- Check the magnet position. The magnet should be installed within 2-8 mm (1/16”-3/8”) of the sensors, according to the instructions on pages **8-10**.
- Make sure the magnet is clean and free of debris.
- Check and replace the battery in the Quarq and/or bike computer.
- **Make sure there is no moisture in the battery compartment.**