

SRT Marine Technology Ltd

Instruction Manual

SRT-MTB Marine Automatic Identification System

Table of contents

Table of contents	2
General Warnings	4
FCC Compliance	4
RF Emissions Notice	5
Product Specification	7
Standards	8
Declaration of Conformity	8
Introduction	9
How AIS Works	9
AIS Classes	10
Position Information Source	10
Installing the SRT-MTB unit	11
Electrical connections	11
Physical Mounting	12
Programming the transponder	13
Programming the transponder	13
Programming software	Error! Bookmark not defined.
Configuration	Error! Bookmark not defined.
Using the transponder	14
Switching on	14
Switch functions	14
Warning and fault states	14
Data port messages	15
Information Transmitted and Received	15
Built In Test	15
LED Indicators	16
Maintenance	17
Serial Data Interface	18
Power Connection / Data Connection	18
Serial Port Input/Output	18

SRT Marine Technology Ltd

Instruction Manual

SRT-MTB Class B Marine AIS

Power up messages	19
VHF data link messages (NMEA 0183 VDM)	19
VHF data link own vessel messages (NMEA 0183 VDO).....	20
Regional Assignment Channel Assignment Message (NMEA 0183 ACA).....	21
Channel management information source messages (NMEA 0183 ACS).....	21
AIS Alarm Messages (NMEA 0183 ALR, Text).....	22
ACK messages	22
Antenna connections	23
GPS Antenna.....	23
VHF Antenna	23
Antenna types and mounting	23
Drawings.....	24
Packing list.....	24
Glossary.....	29
Appendix A	31
Antennas and Antenna Mounting.....	31
GPS Antenna.....	31
VHF antenna for AIS use	31
Warnings.....	32

SRT Marine Technology Ltd

Instruction Manual

SRT-MTB Class B Marine AIS

General Warnings

All marine Automatic Identification System (AIS) units utilise a satellite based system such as the Global Positioning Satellite (GPS) network or the Global Navigation Satellite System (GLONASS) network to determine position.

The accuracy of these networks is variable and is affected by factors such as the antenna positioning, how many satellites are used to determine a position and how long satellite information has been received for.

It is desirable wherever possible therefore to verify both your vessels AIS derived position data and other vessels AIS derived position data with visual or radar based observations.

The compass safe distance of this unit is 0.5m or greater for 0.3° deviation.

In accordance with a policy of continual development and product improvement the SRT-MTB hardware and software may be upgraded from time to time and future versions of the SRT-MTB may therefore not correspond exactly with this manual.

When necessary upgrades to the product will be accompanied by updates or addenda to this manual.

Please take time to read this manual carefully and to understand its contents fully so that you can install and operate your AIS system correctly.

Information contained in this manual is liable to change without notice.

Software Radio Technology plc disclaims any liability for consequences arising from omissions or inaccuracies in this manual and any other documentation provided with this product.

© 2007 Software Radio Technology plc.

FCC Compliance

This equipment has been tested and found to comply with the limits for a Class B digital device, pursuant to part 15 of the FCC Rules. These limits are designed to provide reasonable protection against harmful interference in a residential installation. This equipment generates, uses and can radiate radio frequency energy and, if not installed and used in accordance with the instructions, may cause harmful interference to radio communications. However, there is no guarantee that interference will not occur in a particular installation. If this equipment does cause harmful interference to radio or television reception, which can be determined by turning the equipment off and on, the user is encouraged to try to correct the interference by one or more of the following measures:

- Reorient or relocate the receiving antenna.
- Increase the separation between the equipment and receiver.
- Connect the equipment into an outlet on a circuit different from that to which the receiver is connected.
- Consult the dealer or an experienced radio/TV technician for help.

The SRT-MTB-OEM does not contain any user serviceable parts. Repairs should only be made by an authorized SRT service agent. Unauthorised repairs or modifications could result in permanent damage to the equipment and void your warranty and you're authority to operate this equipment under Part 15 regulations.

SRT Marine Technology Ltd

Instruction Manual

SRT-MTB Class B Marine AIS

RF Emissions Notice

Caution: The SRT-MTB Class B AIS transponder generates and radiates radio frequency electromagnetic energy. This equipment must be installed and operated according to the instructions contained in this handbook. Failure to do so can result in personal injury and / or product malfunction.

Caution: Never operate the transponder unless it is connected to a VHF antenna.

To maximise performance and minimise human exposure to radio frequency electromagnetic energy you must make sure that the antenna is mounted at least 1.5 meters away from the transponder and is connected to the transponder before power is applied.

The system has a Maximum Permissible Exposure (MPE) radius of 1.5m. This has been determined assuming the maximum power of the transponder and using antennas with a maximum gain of 3dBi.

- The antenna should be mounted 3.5m above the deck in order to meet RF exposure requirements.
- Higher gain antennas will require a greater MPE radius.
- Do not operate the unit when anyone is within the MPE radius of the antenna (unless they are shielded from the antenna field by a grounded metallic barrier).
- The antenna should not be collocated or operated in conjunction with any other transmitting antenna.

This device has been designed to operate with standard marine VHF antennas having a maximum gain of 3dBi. Antennas not included in this list or having a gain greater than 3dBi are strictly prohibited for use with this device. The required antenna impedance is 50 ohms.

Licensing and Maritime Mobile Service Identity (MMSI)

IMPORTANT: In most countries the operation of an AIS unit is included under the vessel's marine VHF licence provisions. The vessel on to which the AIS unit is to be installed must therefore possess a current VHF radiotelephone licence which lists the AIS system and the vessel Call Sign and MMSI number.

An MMSI number is required in order for the SRT-MTB transponder to operate.

Please contact the relevant authority in your country for more information.

SRT Marine Technology Ltd

Instruction Manual

SRT-MTB Class B Marine AIS

Static Data Entry

WARNING: It is a violation of the rules of the Federal Communications Commission to input an MMSI that has not been properly assigned to the end user, or to otherwise input any inaccurate data into this device.

The MMSI and Static Data in this transponder must be configured by the vendor of the device or by an appropriately qualified person in the business of installing marine communications equipment on board vessels. In no event shall the entry of static data into this Class B AIS device be performed by the end user. Knowingly programming a Class B AIS device with inaccurate static data, or causing a Class B AIS device to be programmed with inaccurate static data, is prohibited.

Further details on static data programming can be found on page 13.

SRT Marine Technology Ltd

Instruction Manual

SRT-MTB Class B Marine AIS

Product Specification

Parameter	Value
Dimensions	190 x 135 x 83 mm (L x W x H)
Weight	1450g
Power	DC (10.8 - 15.6V) Average power consumption 4W Peak current rating 2A
GPS Receiver (AIS Internal)	IEC 61108-1 compliant
Electrical Interfaces	RS232 38.4kBaud bi-directional RS422 NMEA 38.4kBaud bi-directional
Connectors	VHF antenna connector GPS antenna connector RS232/RS422/Power
VHF Transceiver	Transmitter x 1 Receiver x 2 (One receiver time shared between AIS and DSC) Frequency: 156.025 to 162.025 MHz in 25 kHz steps
Output Power	33dBm \pm 1.5 dB
Channel Bandwidth	25kHz
Channel Step	25kHz
Modulation Modes	25kHz GMSK (AIS, TX and RX) 25kHz AFSK (DSC, RX only)
Bit rate	9600 b/s \pm 50 ppm (GMSK) 1200 b/s \pm 30 ppm (FSK)
RX Sensitivity	Sensitivity - 107dBm 25kHz (Message Error Rate 20%) Co-channel 10dB Adjacent channel 70dB IMD 65dB Blocking 84dB
Environmental	IEC 60945 Operating temperature: -25°C to +55°C IEC 60945 'Protected' category
Indicators	Power, TX timeout, status, pre-set SRM sent.
Operator Controls	Optional pre-set safety related message (SRM) transmit button

SRT Marine Technology Ltd

Instruction Manual

SRT-MTB Class B Marine AIS

Standards

This product complies to all the necessary standards under the European R&TTE directive for Article 3.1(a), 3.1(b), 3.2 and 3.3(e). The following standards have been followed in pursuance of this:

- IEC62287-1: 2006-03 Maritime navigation and radiocommunication equipment and systems – Class B shipborne equipment of the automatic identification system (AIS) – Part 1: Carrier-sense time division multiple access (CSTDMA) techniques
- IEC60945: 2002-08 Maritime navigation and radiocommunication equipment and systems – General requirements – Methods of testing and required test results
- IEC61162-1: Maritime navigation and radiocommunication equipment and systems – Digital interfaces – Part 1: Single talker and multiple listeners
- IEC61108-1: GLOBAL NAVIGATION SATELLITE SYSTEMS (GNSS) – Part 1: Global positioning system (GPS) - Receiver equipment - Performance standards, methods of testing and required test results
- EN 301 843-1 v2.1: Electromagnetic compatibility and Radio spectrum Matters (ERM); Electromagnetic Compatibility (EMC) standard for marine radio equipment and services; Part 1: Common technical requirements
- EN 50383: 2002 Basic standard for calculation and measurement of electromagnetic field strength and SAR related to human exposure from radio base stations and fixed terminal stations for wireless telecommunications system (110MHz – 40GHz)
- EN60950-1:2002 Information technology equipment – Safety – Part 1: General requirements

Declaration of Conformity

Software Radio Technology plc declares that this product is in compliance with the essential requirements and other provisions of the R&TTE directive 1995/5/EC.

The product carries the CE mark, notified body number and alert symbol as required by the R&TTE directive.

The product is intended for sale in the following member states:

Intended Country of Use:

<input type="checkbox"/> GB	<input type="checkbox"/> FR	<input type="checkbox"/> ES	<input type="checkbox"/> SE
<input type="checkbox"/> AT	<input type="checkbox"/> NL	<input type="checkbox"/> PT	<input type="checkbox"/> DK
<input type="checkbox"/> NO	<input type="checkbox"/> BE	<input type="checkbox"/> IT	<input type="checkbox"/> FI
<input type="checkbox"/> IE	<input type="checkbox"/> LU	<input type="checkbox"/> GR	<input type="checkbox"/> CH

SRT Marine Technology Ltd

Instruction Manual

SRT-MTB Class B Marine AIS

Introduction

How AIS Works

The marine Automatic Identification System (AIS) is a location and vessel information reporting system. It allows vessels equipped with AIS to automatically and dynamically share and regularly update their position, speed, course and other information such as vessel identity with similarly equipped craft. Position is derived from a Global Navigation Satellite System (GNSS) network and communication between vessels is by Very High Frequency (VHF) digital transmissions. A sophisticated and automatic method of time sharing the radio channel is used to ensure that even where a large number of vessels are in one location blocking of individual transmissions is minimised, any degradation of the expected position reporting interval is indicated to the user and even if the unit suffers extreme channel overload conditions it will always recover to normal operation.

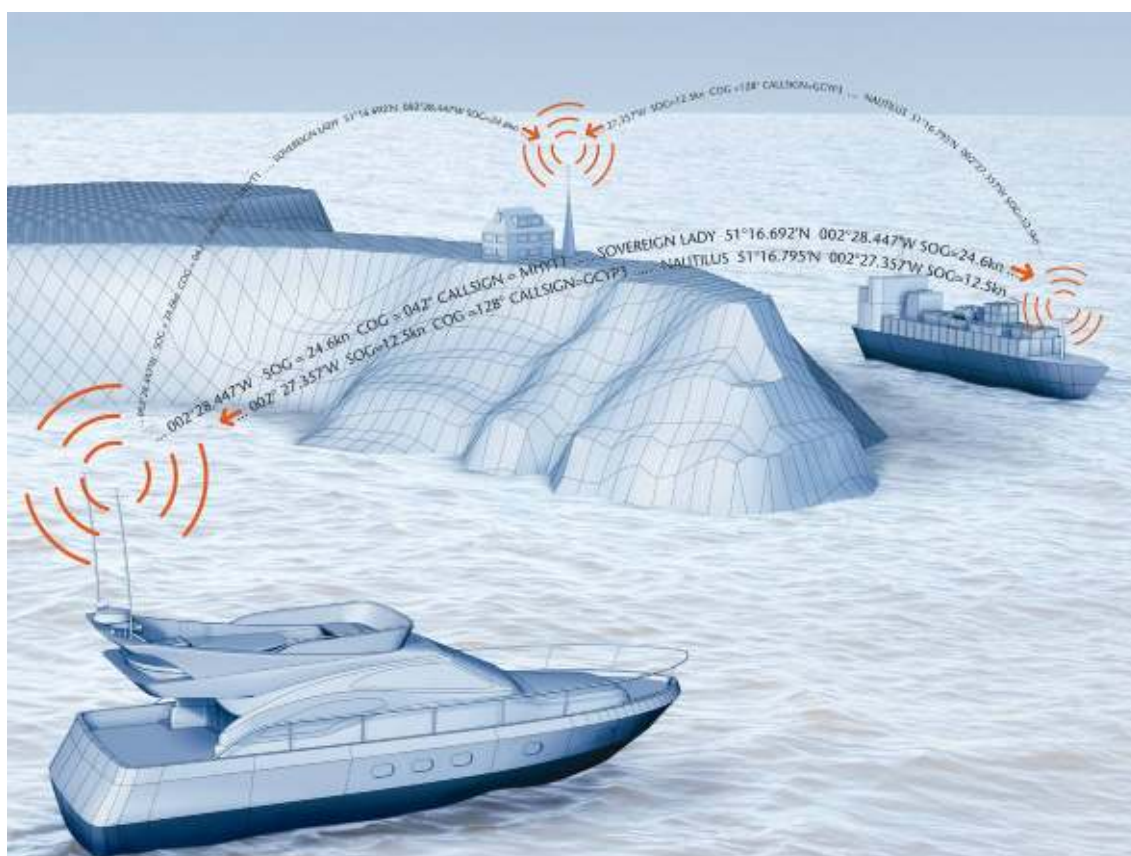

SRT Marine Technology Ltd

Instruction Manual

SRT-MTB Class B Marine AIS

AIS Classes

There are two classes of AIS unit fitted to vessels, Class A and Class B. In addition AIS base stations may be employed by the Coastguard, port authorities and other authorised bodies. AIS units acting as aids to navigation (A to Ns) can also be fitted to fixed and floating navigation markers such as channel markers and buoys.

Class A units are a mandatory fit under the safety of life at sea (SOLAS) convention to vessels above 300 gross tons or which carry more than 11 passengers in International waters. Many other commercial vessels and some leisure craft also fit Class A units.

Class B units are currently not a mandatory fit but authorities in several parts of the world are considering this. Class B units are designed for fitting in vessels which do not fall into the mandatory Class A fit category.

The SRT - MTB is a Class B unit

Position Information Source

As noted above the marine AIS system uses position information derived from networks such as the Global Positioning Satellite (GPS) or the Global Navigation Satellite System (GLONASS) in order to determine the location of the AIS unit and thus the vessel to which it is fitted.

The SRT- MTB utilises the GPS satellite network.

SRT Marine Technology Ltd

Instruction Manual

SRT-MTB Class B Marine AIS

Installing the SRT-MTB unit

- WARNING:** Do not connect the SRT-MTB unit to a mains (line) AC electrical supply, as an electric shock or fire hazard could result.
- CAUTION:** Do not connect the SRT-MTB unit to a DC supply exceeding 15.6 V or reverse the supply polarity. Damage to the unit may result.
- CAUTION:** The SRT-MTB unit is designed for operation in the temperature range -25 °C to +55 °C. Do not install (or use) the SRT-MTB unit in environments which exceed this range.
- CAUTION:** Do not install the SRT-MTB unit in an environment where it can be subject to regular exposure to water.

Electrical connections

Warning: Only the RF, data and power cables provided with the SRT-MTB unit should be used to connect antennas, power and display devices so as to maintain the integrity of the enclosure.

Please see the drawings section of this manual for details of the power, data and RF cables supplied.

Remove the top of the transponder unit (eight screws) as shown.

Using the two co-axial leads supplied connect the down-lead from a VHF antenna to the VHF antenna port and connect the down-lead of a GPS antenna to the GPS antenna port. Please see Appendix A for recommendations on antennas and antenna installation.

If an external display unit (chart plotter, PC etc) is to be used connect the supplied power and data interface cable to the Power / NMEA port.

If an external display unit is not to be used connect the supplied power only interface cable to the Power / NMEA port.

Locate the RF, power and/or data cables into the rubber grommets pushing them firmly to the base of each slit. Each cable is pushed into the grommet slit which lies directly in front of the connector the cable is connected to.

Replace the top of the transponder unit taking care to seat the cable grommets and the lid seal correctly. Do not over-tighten the fixing screws.

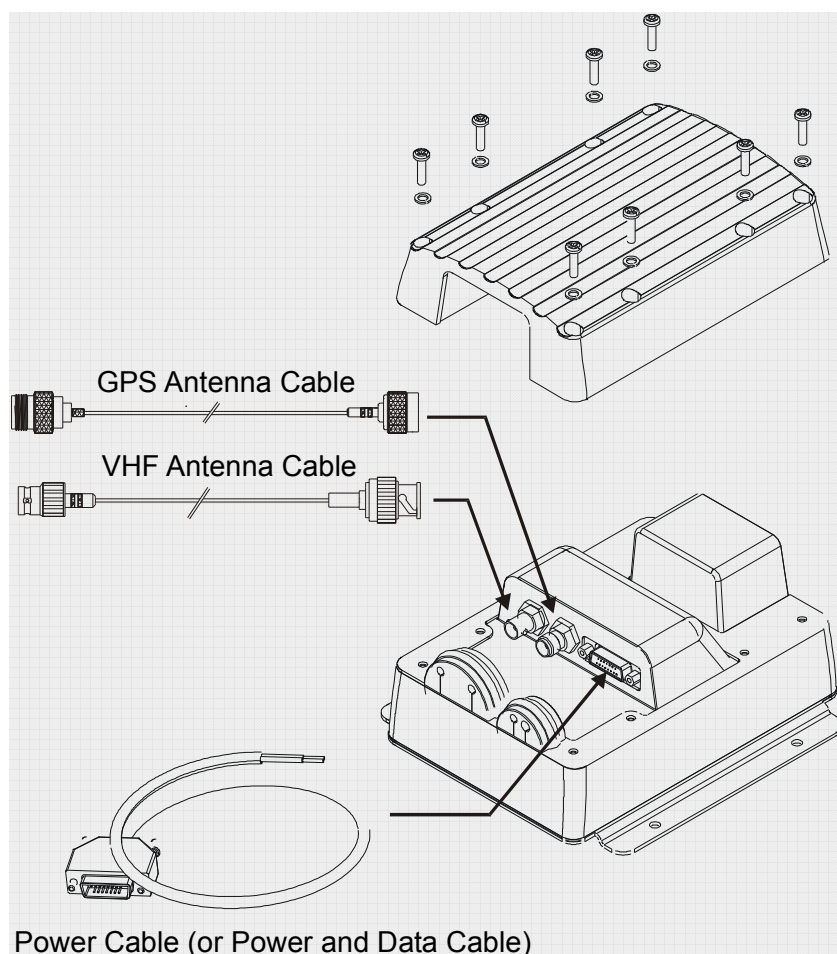

SRT Marine Technology Ltd

Instruction Manual

SRT-MTB Class B Marine AIS

If an external display unit is to be used (such as a chart plotter, PC serial terminal or other display device) connect the user end of the data interface cable to the display device. Note that the software in the display device must be configured for AIS operation AND to accept standard Class B operation NMEA sentences. This external display unit software is not part of the SRT-MTB transponder package.

Connect a 12V DC supply (9.6-15.6V) capable of supplying 2A peak to the DC power lead (brown/red = positive, black/blue=negative).

The case of the unit is not isolated from the negative terminal of the supply and therefore it is recommended that the unit is not attached to metal parts of the vessel.

Physical Mounting

It is recommended that the unit is attached to a solid wooden surface with 20mm M3 self tapping screws. A template for drilling pilot holes is shown on page 25.

Programming the transponder

Before the SRT-MTB can be used as a transponder it requires configuration with vessel data. This configuration will be carried out by the vendor of the transponder using data for your vessel. You will need to provide the vendor of the transponder with the following information:

- Your MMSI number
- Your vessel name
- Your vessel callsign
- Your vessel dimensions
- The location of the AIS GPS antenna on your vessel (or planned installation location)
- The type of vessel from the list below

Instructions for programming the transponder are provided to registered vendors of the SRT-MTB and are not available to end users.

SRT Marine Technology Ltd

Instruction Manual

SRT-MTB Class B Marine AIS

Using the transponder

Switching on

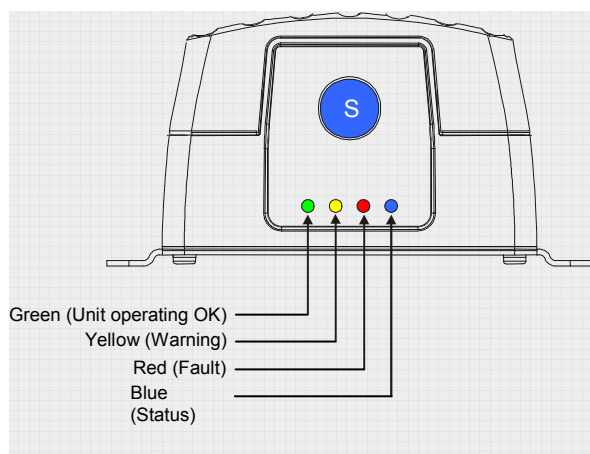

When the 12V supply is switched on all four LEDs visible on the front panel of the unit will illuminate twice for a period of one second on each illumination. The red and blue LEDs will then go out. When the internal GPS starts outputting valid position information and the SRT MTB unit transmits its first position report (message 18) the yellow LED will go out; note that this process may take up to 30 minutes depending on the switch-on state of the GPS receiver. When the yellow LED goes out the green LED will illuminate indicating that the unit is now operating correctly.

Switch functions

The blue switch on the front of the unit can be configured **either** to trigger transmission of a "Safety Related Message" or to place the unit into "Silent mode". This choice is made during configuration of the unit using the proAIS application; please refer to the proAIS user guide for further information on the configuration options.

When configured to transmit a "Safety Related Message" the button will initiate broadcast of an AIS message containing the vessels MMSI along with the text "MAYDAY MAYDAY". The button must be pressed for at least two seconds to initiate this transmission and the blue LED will illuminate to indicate the message has been sent. Additional "Safety Related Messages" can not be sent until the blue LED has extinguished which will occur one minute after an SRM has been sent.

When configured to place the unit into "Silent mode" each press of the switch will toggle the AIS transmitter on or off. The switch must be depressed for two seconds to change the state of the transmitter. When the transmitter is off, the yellow "Warning" LED and blue "Status" LEDs will be illuminated and the transponders position will not be broadcast to other vessels. The position of other vessels will still be received by the unit.

Warning and fault states

If the unit has not been able to transmit a position report during the last expected two reporting intervals (i.e. the nominal reporting interval cannot be maintained for operational reasons such as a Message 23 quiet period, high channel load conditions, etc) the yellow LED will illuminate. This is a warning condition only and indicates that your vessels position is not currently being reported to other vessels. Reception of other vessel AIS information by the SRT-MTB is not affected. When the unit is able to commence reporting the yellow LED goes out.

If a fault occurs the red LED will illuminate. This may illuminate briefly if the power supply is interrupted or if the VHF antenna characteristics are briefly affected.

If the Red LED illuminates continuously the unit should be assumed to be faulty and should either be switched off (power removed) or if this is not practical any other vessel position information derived from the unit should not be used and it should

SRT Marine Technology Ltd

Instruction Manual

SRT-MTB Class B Marine AIS

also be assumed that the unit is not transmitting valid position information for your vessel.

The unit should be examined by a competent equipment maintainer at the earliest opportunity.

Data port messages

The data port will output the following:

- (At power-up) boot-loader and main application splash text screens including version numbers, and memory status
- Details of relevant AIS transmissions received
- Details of AIS transmissions sent
- Details of channel management messages received
- Alarm messages generated by the BIIT function

The data port will accept the following inputs:

- Programming information
- Alarm acknowledgements

Please see the 'Data Interface' section of this manual for more details of the data port messages.

When in operation an AIS unit:

- Uses one of two VHF channels within the international marine band allocation (channel 87B; 161.975MHz, or channel 88B; 162.025MHz) to regularly transmit information such as the vessel position, Maritime Mobile Service Identity (MMSI), name, speed, course, etc.
- Receives similar information from other AIS equipped vessels within VHF range and outputs that information for use by an external display medium (AIS enabled chart plotter, PC using AIS enabled chart plotter software etc.)

Information Transmitted and Received

A Class A unit will transmit its IMO number (if known), MMSI, Call sign and Name, length and beam, ship type, time, course over ground (COG), speed over ground (SOG), heading, navigational status, rate of turn, draught, cargo type, destination and safety related messages via a short message service (SMS) facility. Message lengths are variable with static and voyage related information being transmitted less often.

A Class B unit will transmit its MMSI, Call Sign and Name, length and beam, ship type, time, course over ground (COG), speed over ground (SOG) and heading*

** Heading information is only transmitted if a suitable sensor which outputs NMEA 'True Heading' data (HDT) is connected to the transponder and the transponder configured to accept this data.*

Built In Test

The SRT- MTB unit is equipped with Built In Integrity Testing (BIIT). BIIT tests run continuously or at appropriate intervals simultaneously with the standard functions of the equipment. The BIIT detects any failure or malfunction that will significantly reduce integrity or stop operation of the SRT- MTB unit.

SRT Marine Technology Ltd

Instruction Manual

SRT-MTB Class B Marine AIS

The tests include:

- AIS TX malfunction (synthesiser not locked and TX time-out not exceeded)
- Antenna VSWR exceeds limit
- Rx channel 1 malfunction (synthesiser not locked)
- Rx channel 2 malfunction (synthesiser not locked)
- Internal GNSS not in use
- No valid SOG information
- No valid COG information
- Background noise > -77dBm
- GPS failure
- VSWR exceeding the maximum allowed level
- The input voltage is out of the specified range

LED Indicators

Power

This is a green LED which indicates, when lit, that power has been connected correctly to the transponder, that the transponder hardware has been configured, that the operating software is present, that the CPU has booted up, the application software is running.

TX Timeout

This is a yellow LED which indicates when lit that the CSTDMA transmitter is prevented from transmitting. Reasons for this include the following:

- The transponder's internal GPS receiver is not operating or is not yet ready. [1] requires that a class B CSTMA transponder shall not transmit if its internal position sensor is not operating
- The transponder was unable to transmit an AIS message due to the channel being already occupied, e.g. by transmissions from other AIS transponders
- The transponder is in "Silent mode"

Error

This is a red LED which indicates, when lit, one of the following status conditions is possible:

- Transmitter lockout timer (1 second maximum) has operated
- GPS is unable to gain lock after 30 minutes
- VHF antenna VSWR is out of range
- Power supply is out of range
- Background noise level is above the threshold level (-77dBm)

SRT Marine Technology Ltd

Instruction Manual

SRT-MTB Class B Marine AIS

Status

This is a blue LED which **either** indicates that a Safety Related Message has been transmitted **or** that the unit is in "Silent mode". The condition indicated by the blue LED is determined during configuration of the unit by the switch option selected. Please refer to the "Switch functions" section of this manual for more detail.

- Transmission of a Safety Related Message is indicated by both the green and blue LEDs being illuminated

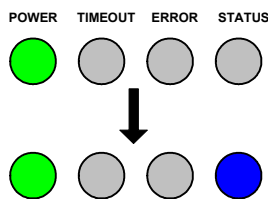

- Silent mode is indicated by both the yellow and blue LEDs being illuminated.

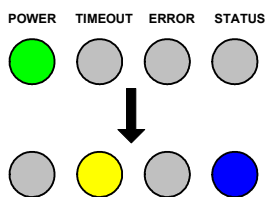

Antennas

The SRT - MTB unit requires VHF and GPS antennae independent from those in use for other purposes. Please see Appendix A for details of the antennae required.

Maintenance

WARNING: Unauthorised opening of the SRT-MTB system will invalidate the warranty.

CAUTION: Avoid using chemical solvents to clean the SRT-MTB as some solvents can damage the case material.

NOTE: The SRT-MTB contains no user serviceable parts. Contact your Service Agent for repair if replacing the fuse fails to make the equipment serviceable.

Serial Data Interface

Power Connection / Data Connection

There is a 15-way D-type male connector mounted under the transponder top cover. The standard data or power and data cable assembly provided mates with this connector.

Power

12V DC (9.6-15.6V) is connected to the transponder power supply input via the cable assembly LD1873.

Data

A PC, chart plotter or other NMEA compatible display device may be connected to the SRT-MTB OEM unit via the appropriate cable assembly. The default baud rate of the data link is 38.4kBaoud with 8 data bits, one stop bit and no parity. No handshaking is used.

The data interface conforms to IEC 61162-1.

VDM, VDO, ACA, ACS, ALR, TXT and ACK messages conform to NMEA 0183. Please refer to NMEA 0183 for full details of these AIS messages.

Serial Port Input/Output

There are two serial ports, one presenting RS422 format and the other RS232 format. Data can be input from either or both ports.

The serial port interface(s) output:

- At power-up boot-loader and main application splash text screens including version numbers and memory status.
- As a VHF Data Link Message (VDM) all incoming VHF Data Link (VDL) data received by the SRT-MTB.
- The VHF data link own vessel (VDO) messages sent by the SRT-MTB over the VHF Data Link.
- AIS regional channel assignment messages (ACA) received. These are derived from an incoming VHF Data Link message (message 22) or a DSC message.
- AIS channel management information source (ACS) messages.
- Alarm messages (ALR, TXT).

The data interface will accept:

- Personality programming messages
- Alarm acknowledgement messages (ACK)

SRT Marine Technology Ltd

Instruction Manual

SRT-MTB Class B Marine AIS

Power up messages

On power up the unit will report details of the firmware versions residing in the unit.

VHF data link messages (NMEA 0183 VDM)

Receipt of a VHF Data Link (VDL) message on either AIS radio channel causes a VDM message to be output via the data port. Please see IEC 61193-2, Annex B for a list of messages.

VDM Message Format

```
!-VDM,x1,x2,x3,a,s--s,x*hh<CR><LF>
```

Where:

- x1 = Total number of sentences needed to transfer the message , 1 to 9
- x2 = Sentence number, 1 to 9
- x3 = Sequential message identifier, 0 to 9
- a = AIS Channel, "A" or "B"
- s - - s = Encapsulated ITU-R M.1371 radio message
- x = Number of fill-bits , 0 to 5

VDM Message Types

For example, the information contained in the s - - s portion of the VDM = Encapsulated ITU-R M.1371 radio message. Note that messages 5 and 19 may be sent as multi part messages using the x1, x2 and x3 parameters for message sequence control.

VDL Message number	VDM Message description
AIS Target Display Information	
1, 2, 3, 9,18, 21	position report
4	base station report
5*	voyage related data
19*	Class B – extended data
Safety message handling	
12	addressed safety related
14	broadcast safety related
External Application handling	
8	binary broadcast
System control	

SRT Marine Technology Ltd

Instruction Manual

SRT-MTB Class B Marine AIS

VDL Message number	VDM Message description
13	safety related ack (INFO)
15	interrogation (INFO)
17	DGNSS corrections (INFO)
20	data link management (INFO)
22	channel management (INFO)
23	Group assignment (INFO)

*Note that messages 5 and 19 may be sent as multi part messages.

VHF data link own vessel messages (NMEA 0183 VDO)

This message describes the own vessel message being sent.

VDO Message Format

```
!-VDO,x1,x2,x3,a,s--s,x*hh<CR><LF>
```

Where

- x1 = Total number of sentences needed to transfer the message , 1 to 9
- x2 = Sentence number, 1 to 9
- x3 = Sequential message identifier, 0 to 9
- a = AIS Channel, "A" or "B"
- s - - s = Encapsulated ITU-R M.1371 radio message 4
- x = Number of fill-bits , 0 to 5

VDO Message number	VDO Message description
AIS Target Display Information	
13	Safety Related Acknowledgement
14	Safety Related Broadcast message (default contents are MMSI and text "MAYDAY MAYDAY")
18	Standard Class B position report (Includes MMSI, SOG, position accuracy, lat, long, COG, true heading,)
19	Extended Class B position report (transmitted in response to base station interrogation only)
24A	Class B "CS" Static data Part A (Includes MMSI and vessel name)
24B	Class B "CS" Static data Part B (MMSI, ship type, cargo type, call sign, ship dimensions)

SRT Marine Technology Ltd

Instruction Manual

SRT-MTB Class B Marine AIS

Regional Assignment Channel Assignment Message (NMEA 0183 ACA)

An SRT-MTB unit can receive regional channel management information in two ways: ITU-R M.1371 message 22 or a DSC telecommand received on channel 70,

ACA Message Format

```
$--ACA,x,IIII,II,a,yyyyy.yy,a,IIII,II,a1,y1y1y1y1y1y1,a2,x1,x2x2x2x2,x3,x4x4x4x4,x5,x6,x7,a3,x8,hhmmss.ss*hh
<CR><LF>
```

Where

- x = Sequence Number , 0 to 9
- IIII, II, a = Region Northeast corner latitude – N/S
- yyyyy.yy,a1 = Region Northeast corner longitude – E/W
- IIII,II,a = Region Southwest corner latitude – N/S
- y1y1y1y1y1.y1y1,a2 = Region Southwest corner longitude – E/W
- x1 = Transition Zone Size
- x2x2x2x2 = Channel A
- x3 = Channel A bandwidth
- x4x4x4x4 = Channel B
- x5 = Channel B bandwidth
- x6 = Tx/Rx mode control
- x7 = Power level control
- a3 = Information source
- x8 = In-Use Flag
- hhmmss.ss = Time of "in-use" change

Channel management information source messages (NMEA 0183 ACS)

This sentence is used in conjunction with the ACA sentence and identifies the originator of an ACA message.

ACS Message Format

```
$--ACS,x,xxxxxxxx, hhmmss.ss,xx,xx,xxxx*hh <CR><LF>
```

- x = Sequence Number , 0 to 9
- xxxxxxxx =MMSI of originator
- hhmmss.ss = UTC of receipt of channel management information
- xx = UTC Day, 01 -31
- xx = UTC Month, 01 -12

SRT Marine Technology Ltd

Instruction Manual

SRT-MTB Class B Marine AIS

- xxx = UTC Year

AIS Alarm Messages (NMEA 0183 ALR, Text)

ALR message format

```
$--ALR,hhmmss.ss,xxx,A,A,c--c*hh<CR><LF>
```

Where

- hhmmss.ss = Time of alarm (UTC)
- xxx = Unique alarm number
- A = Alarm condition
- A = Alarm acknowledge state
- c--c = alarm description, text

Alarms descriptions presented are:

- AIS: TX malfunction
- AIS: Antenna VSWR exceeds limit
- AIS: Rx channel 1 malfunction
- AIS: Rx channel 2 malfunction
- AIS: general failure
- AIS: no sensor position in use
- AIS: no valid SOG information
- AIS: no valid COG information
- AIS: 12V alarm
- AIS: 5V alarm
- AIS: Loss of serial interface integrity
- AIS: Background noise above -77dBm

ACK messages

Can be generated by a minimum keypad and display (MKD) unit, chart plotter or other display device connected to the SRT-MTB to acknowledge an alarm condition reported by the SRT-MTB.

ACK message format

```
$--ACK,xxx*hh <CR><LF>
```

Where

- xxx = unique alarm number

SRT Marine Technology Ltd

Instruction Manual

SRT-MTB Class B Marine AIS

Antenna connections

GPS Antenna

This is a TNC female bulkhead connector mounted under the unit top cover. This port provides the 5V DC feed for the active GPS antenna required by the SRT-MTB unit.

VHF Antenna

This is a BNC female bulkhead connector mounted under the unit top cover.

Antenna types and mounting

Please see Appendix A for antenna details.

SRT Marine Technology Ltd

Instruction Manual

SRT-MTB Class B Marine AIS

Drawings

Packing list

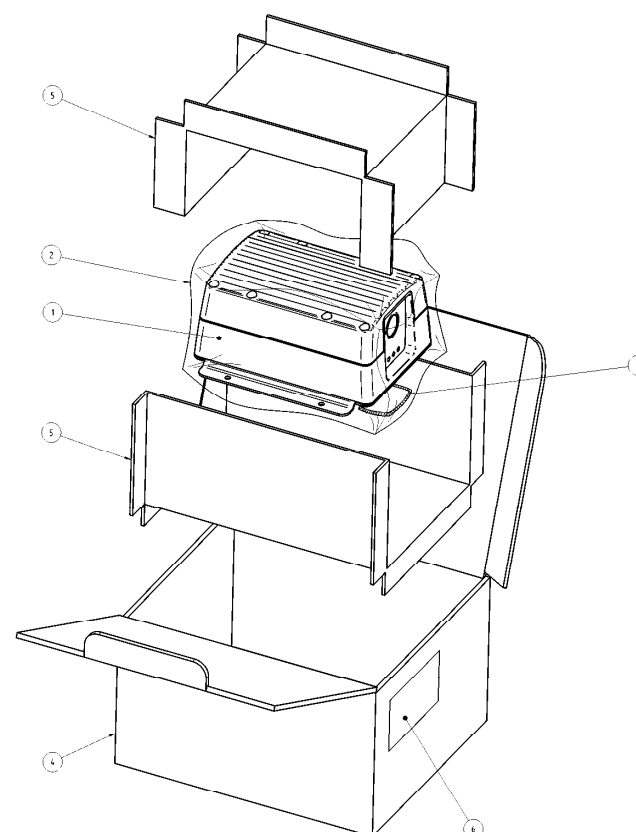

REV	DESCRIPTION	DATE	APPROVED
1	PRODUCTION RELEASE	23/2/06	
2	MAGNET PACK REMOVED	15/6/06	
3	SCREW FIXING KIT REMOVED	28/11/07	
4	CABLE AND INSTRUCTIONS REMOVED	2/2/07	

ITEM	SRT PART No.	DESCRIPTION	QTY
1	LD2005	AIS CLASS B TRANSponder UNIT	1
2	NA	POLYTHENE BAG 300 x 300 mm	1
3	NA	SILICA GEL SACHET	1
4	1700968	FOAMER PACKING CARTON	1
5	LD2009	INNER PACKING (2 ITEMS)	1
6	NA	CARTON IDENTIFICATION LABEL	1

NA = NOT APPLICABLE

DRAWN	REFER TO LIST	FOR IDENT		SOFTWARE RADIO TECHNOLOGY PLC	
		WESTFIELD INDUSTRIAL ESTATE MIDDLESBRIDGE INDUSTRIAL PARK, UK		MIDDLESBRIDGE INDUSTRIAL PARK, UK	
DATE	SCALE	FOR IDENT		AIS CLASS B TRANSponder PACKED ASSEMBLY	
		SCALE 1:1		SCALE 1:1	
DRAWN BY		DATE		QTY	
LD2114		23/2/06		4	

SRT Marine Technology Ltd

Instruction Manual

SRT-MTB Class B Marine AIS

Fixing Template (NOT TO SCALE)

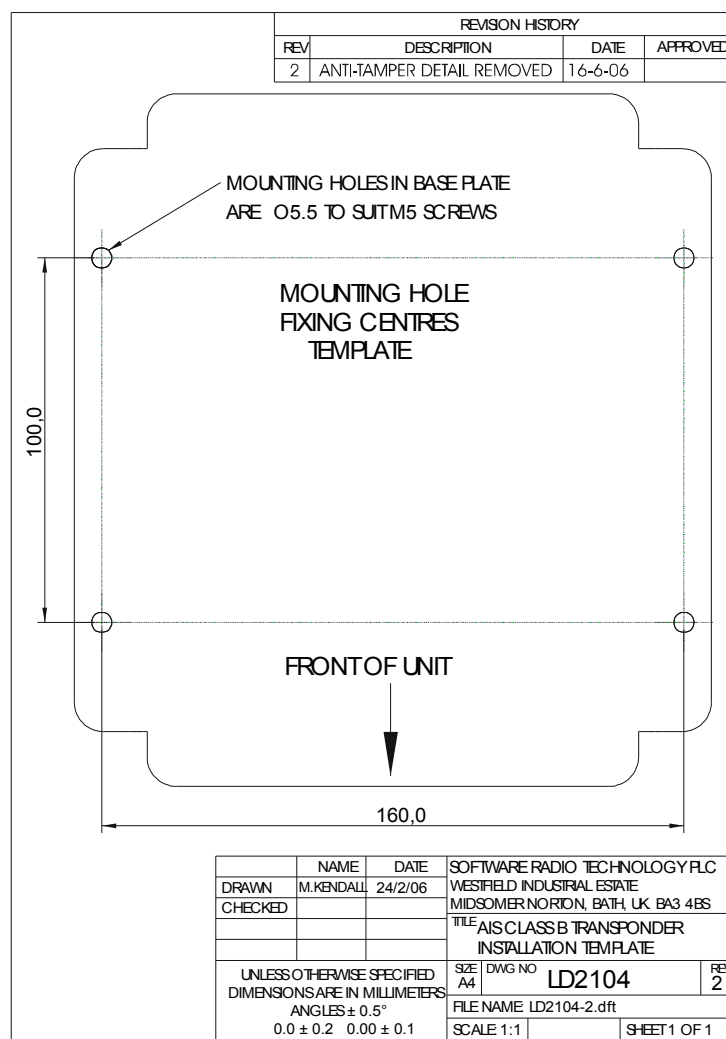

SRT Marine Technology Ltd

Instruction Manual

SRT-MTB Class B Marine AIS

General arrangement

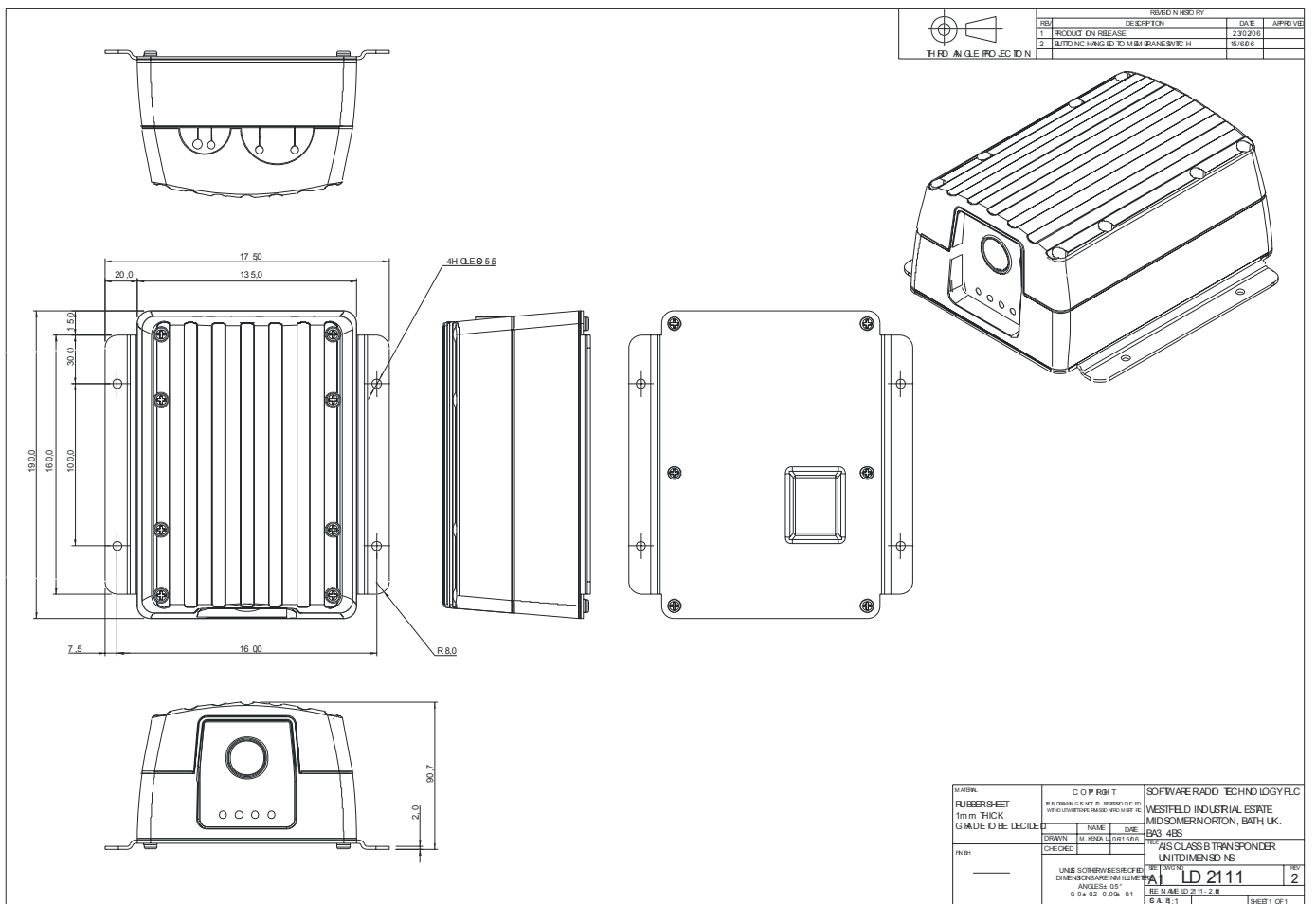

SRT Marine Technology Ltd

Instruction Manual

SRT-MTB Class B Marine AIS

Mechanical Breakdown

REVISION HISTORY			
REV	DESCRIPTION	DATE	APPROVED
1	PRODUCTION RELEASE	23/02/08	
2	ITEM 24 ADDED	21/03/08	
3	ITEM 25 ADDED	10/04/08	
4	MECHANICAL SWITCH DETAIL REMOVED	15/06/08	
5	LABEL WITHOUT SWITCH AND PRODUCT SPECIFICATION LABEL REMOVED	26/1/07	

ITEM	SRT PART No.	DESCRIPTION	QTY
1	LD1999	COVER	1
2	LD2002	COVER GASKET	1
3	LD2000	CHASSIS	1
4	LD2007	PCB ASSEMBLY	1
5	LD2003	BASE PLATE GASKET	1
6	LD2001	BASE PLATE	1
7	LD2073	CABLE GLAND LARGE	1
8	LD2074	CABLE GLAND SMALL	1
---	---	---	---
---	---	---	---
---	---	---	---
12	NA	M4 x 16mm PAN HEAD CROSS DRIVE SCREW, STAINLESS STEEL 316	8
13	NA	M4 x 10mm PAN HEAD CROSS DRIVE SCREW, STAINLESS STEEL 316	9
14	NA	M4 SPRING WASHER, STAINLESS STEEL 316	14
15	NA	M3 x 8mm PAN HEAD CROSS DRIVE SCREW, STEEL, ZINC PLATE	6
16	NA	M3 PLAIN WASHER, STEEL, ZINC PLATE	6
17	NA	M3 SPRING WASHER, STEEL, ZINC PLATE	6
18	LD2091	INTERNAL GPS CABLE ASSEMBLY, BNC CONNECTOR	1
19	LD2090	INTERNAL VHF CABLE ASSEMBLY, BNC CONNECTOR	1
20	LD2093	INTERNAL PARALLEL RIBBON CABLE ASSEMBLY	1
---	---	---	---
---	---	---	---
23	NA	SUB D CONNECTOR M3 SCREW PILLAR FIXING KIT	1
24	LD2116	MEMBRANE SWITCH PANEL ASSEMBLY	1
---	---	---	---
NA = NOT APPLICABLE			

DRAWN: _____ CHECKED: _____ DATE: _____ BY: _____	TOLERANCES: UNLESS OTHERWISE SPECIFIED DIMENSIONS ARE IN MILLIMETERS UNLESS OTHERWISE SPECIFIED UNLESS OTHERWISE SPECIFIED UNLESS OTHERWISE SPECIFIED	SOFTWARE RADIO TECHNOLOGY PLC WESTFIELD INDUSTRIAL ESTATE MIDDERHAM NORTON BATH, UK. BA3 4BS 'AIS CLASS B' TRANSPONDER GENERAL ASSEMBLY SRT LD 2007 SHEET 5 OF 5 SCALE: 0.8x1.0 SHEET 1 OF 2
------------------------------------------------------------	----------------------------------------------------------------------------------------------------------------------------------------------------------------	----------------------------------------------------------------------------------------------------------------------------------------------------------------------------------------------------------------------------

SRT Marine Technology Ltd

Instruction Manual

SRT-MTB Class B Marine AIS

Cable Assemblies

ITEMS LIST

1. POWER CABLE ----1000mm
 --2 CONDUCTOR CABLE: 18AWG, OD=0.23"=5.84MM
 --PVC INSULATION, UNSHIELDED,PVC JACKET
 --TINNED COPPER CONDUCTORS eg. FARNELL 71-398
2. DATA CABLE ----1000mm
 --7 CONDUCTOR CABLE: 22AWG, OD=0.21"=5.3MM
 --PVC INSULATION, UNSHIELDED,PVC JACKET
 --TINNED COPPER CONDUCTORS eg. FARNELL 380-480
3. --15 PINS, D PLUG, MALE eg. RS 381-5940
 --PLAIN PLASTIC 15 WAYS D SHELL WITH SCREW LOCK eg. RS 381-5940
4. --9 PINS, D SOCKET, FEMALE eg. RS 375-2285
 --PLAIN PLASTIC 9 WAYS D SHELL WITH SCREW LOCK eg. RS 484-789
5. --1072RUEFF135A0 1.35A RESETTABLE FUSE
 --RAYCHEM RUEF135 -- 2 OFF

PINS CONNECTION		D TYPE PINS NUMBER	
CABLE	WIRE COLOUR	15 WAYS D TYPE PLUG	9 WAYS D TYPE SOCKET
2 WAYS POWER	BLUE	9 VIA ITEM 5	1
7 WAYS DATA			
		15 WAYS PLUG	9 WAYS SOCKET
		RED	2
		BLUE	3
		GREEN	5
		14 VIA ITEM 5	
RS422 TXA (+)	ORANGE	2	FREE END
RS422 TXB (-)	BLACK	10	FREE END
RS422 RXA (+)	BROWN	3	FREE END
RS422 RXB (-)	WHITE	11	FREE END

REVISIONS			
REV	DESCRIPTION	DATE	BY
1	FIRST ISSUES	24.02.05	MC
2	Change Cable Length	23.02.06	MC
3	Change Cable Length	23.02.06	MC
4	Change Cable Length	4.07.07	ASPT/RV
5	Change Cable Length	1.11.07	ASPT/RV
6	Change Cable Length	21.05.08	DH

DATE	24.02.05	Drawn	MC
FINISH		Checked	
REMOVE BURRS AND SHARP EDGES			
ALL DIMS mm			
30% TOLERANCE SPECIFICATION			
DO NOT SCALE PRINT			
Copyright			
ALL RIGHTS RESERVED			
MANUFACTURE BY			
MANUFACTURE AT			
ALL DIMENSIONS TO BE SHOWN ON DRAWING			
The drawing shall not be reproduced			
without written permission			
SCALE	1	OF	1

Power, RS232 and RS422 (NMEA 0183) data cable

Glossary

ACA	(AIS) Regional Assignment Channel Assignment Message
ACK	Acknowledgement
ACS	(AIS) Channel management information source messages
AFSK	Audio frequency-shift keying
ALR	(AIS) Alarm Message
A to N	Aid to Navigation
AIS	Automatic Identification System
BIIT	Built In Integrity Testing
BNC	Bayonet fitting type RF connector
CSTDMA	Carrier Sense Time Division Multiple Access
COG	Course over Ground
CR	Carriage Return
CS	Carrier Sense
CSTDMA	Carrier Sense TDMA
DC	Direct Current
DGNSS	Differential Global Navigation Satellite System
DSC	Digital Selective calling
GLONASS	Global Navigation Satellite System
GNSS	Global Navigation Satellite System
GMSK	Gaussian Minimum Shift Keying
GPS	Global Positioning Satellite / System
HF	High Frequency
IMO	International Maritime Organization
IEC	International Electrotechnical Commission
LED	Light Emitting Diode
LF	Line Feed
LNA	Low-noise amplifier
MF	Medium Frequency
MKD	Minimum Keypad and Display
MMSI	Maritime Mobile Service Identity
MPE	Maximum Permissible Exposure

SRT Marine Technology Ltd

Instruction Manual

SRT-MTB Class B Marine AIS

NMEA	National Marine Electronics Association
PC	Personal Computer
PI	Presentation Interface
RF	Radio Frequency
RTCM	Radio Technical Commission for Maritime Services Commission
RX	Receive or Receiver
RFI	Radio frequency interference
SAR	Specific Absorption Rate
SMS	Short Message System
SOG	Speed over Ground
SRM	Safety Related Message
SRT	Software Radio Technology
TDMA	Time-division Multiple Access
TNC	Threaded type BNC connector
TX	Transmit or transmitter
UTC	Universal Time Co-ordinated
VDM	(AIS) VHF Data Link Messages
VDO	(AIS) VHF data link own vessel messages
VHF	Very High Frequency
VSWR	Voltage Standing Wave Ratio

Appendix A

Antennas and Antenna Mounting

GPS Antenna

The GPS antenna used must be of the active type (i.e. it should incorporate an LNA) and must be suitable for marine shipboard applications (index of protection, ruggedness, means of mounting, etc.). An antenna should be selected with a gain (in dB) depending on the length of cable between the antenna and the AIS unit; after subtraction of cable and connector losses a minimum total gain of 25 dB should be available at the SRT-MTB unit GPS antenna connector.

The GPS antenna to be used for AIS use must be a dedicated antenna, i.e. not shared with any other GPS receiver.

Installation of the GPS antenna is critical for the performance of the built in GPS receiver which is used for timing of the transmitted time slots and for the supply of navigational information should the main navigational GPS fail. We strongly recommend that:

- The GPS antenna is mounted in an elevated position and free of shadow effect from the ship's superstructure
- The GPS antenna has a free view through 360 degrees with a vertical angle of 5 to 90 degrees above the horizon.
- As the received GPS signal is very sensitive to noise and interference generated by other onboard transmitters, ensure that the GNSS antenna is placed as far away as possible from radar, Inmarsat and Iridium transmitters and ensure the GPS antenna is free from direct view of the radar and the Inmarsat beam.
- It is also important that the MF/HF and other VHF transmitter antennas are kept as far away as possible from the GNSS antenna. It is good practice never to install a GNSS antenna within a radius of 5 meters from these antennas.

VHF antenna for AIS use

The VHF antenna employed for AIS use:

- Should be a dedicated antenna unless using an antenna splitter specifically designed for use with an AIS Transponder. Note that antenna splitters for AIS receiver applications are not suitable and will result in malfunction.
- Must be suitable for marine shipboard applications (index of protection, ruggedness, means of mounting, etc.)
- Should be omni-directional and vertically polarised with maximum gain of 3dBi and bandwidth sufficient to maintain VSWR <1.5 over the frequency range 156 – 163 MHz. As a minimum the 3dB bandwidth must cover the two AIS channels and the DSC Channel.
- Should be mounted with at least a two metre vertical separation distance from any other VHF antenna used for speech or DCS communication but see also the section "Radio Frequency Exposure Warning" below.

SRT Marine Technology Ltd

Instruction Manual

SRT-MTB Class B Marine AIS

Warnings

VHF Antenna Connection

Connecting a badly mismatched VHF antenna, leaving the VHF antenna port disconnected, or shorting the VHF antenna port will activate the VSWR alarm, cause the unit to stop sending position reports or cause damage to the transponder.

Radio Frequency Exposure

To meet the requirements for Radio Frequency Exposure it is necessary to install the VHF antenna correctly and operate the AIS equipment according to the instructions.

SRT Marine Technology Ltd

Instruction Manual

SRT-MTB Class B Marine AIS

SRT Marine Technology Ltd is at the forefront of technology innovation and for this reason, reserves the right to alter, without notice, the specification, design or conditions of supply of any product or service. Information provided by SRT Marine Technology is believed to be accurate and reliable. However, no responsibility is assumed by SRT Marine Technology for its use, nor any infringements of patents or other rights of third parties, which may result from its use. No license is granted by implication or otherwise under any patent or patent rights of SRT Marine Technology. SRT Marine Technology is a member of the SRT plc group. SRT plc operates to the ISO 9001-2000 standards.
© SRT Marine Technology Ltd 2008.



SRT
Marine Technology

SRT Marine Technology Ltd
Wireless House
Westfield Industrial Estate
Midsomer Norton
Bath BA3 4BS
England UK

Tel: +44 (0)1761 409 500
Fax: +44 (0)1761 410 093

email: enquiries@srt-marine.com
www.srt-marine.com