

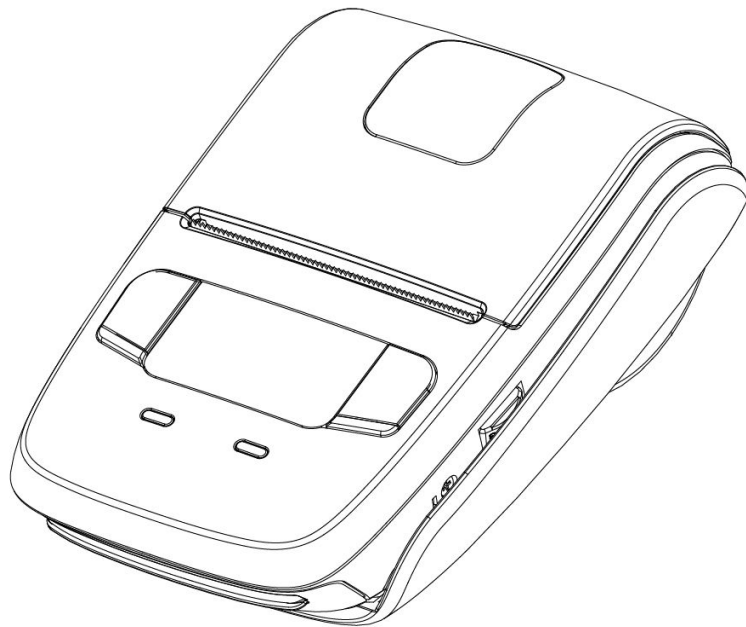

Mobile Printer SM-L204 SERIES

**PRODUCT
SPECIFICATIONS**



<USA model>

**Federal Communications Commission
Radio Frequency Interference Statement**

This device complies with Part 15 of the FCC Rules. Operation is subject to the following two conditions: (1) This device may not cause harmful interference, and (2) this device must accept any interference received, including interference that may cause undesired operation.

CAUTION: Changes or modifications not expressly approved by the party responsible for compliance could void the user's authority to operate the equipment.

Note: This equipment has been tested and found to comply with the limits for a Class B digital device, pursuant to part 15 of the FCC Rules. These limits are designed to provide reasonable protection against harmful interference in a residential installation. This equipment generates, uses and can radiate radio frequency energy and, if not installed and used in accordance with the instructions, may cause harmful interference to radio communications.

However, there is no guarantee that interference will not occur in a particular installation. If this equipment does cause harmful interference to radio or television reception, which can be determined by turning the equipment off and on, the user is encouraged to try to correct the interference by one or more of the following measures:

- Reorient or relocate the receiving antenna.
- Increase the separation between the equipment and receiver.
- Connect the equipment into an outlet on a circuit different from that to which the receiver is connected.

FCC WARNING

Changes or modifications not expressly approved by the party responsible for compliance could void the user's authority to operate the equipment. For compliance with the Federal Noise Interference Standard, this equipment requires a shielded cable. For RF interference suppression, if a ferrite core is provided with this device, affix it to the interface cable.

The above statement applies only to equipments marketed in U.S.A.

<Europe model>

- English: Hereby, STAR MICRONICS CO.,LTD. declares that this Wireless Device is in compliance with the essential requirements and other relevant provisions of Directive 1999/5/EC
- Deutsch: Hiermit erklärt STAR MICRONICS CO.,LTD., dass sich das Gerät Wireless Device in
[German] Übereinstimmung mit den grundlegenden Anforderungen und den übrigen einschlägigen Bestimmungen der Richtlinie 1999/5/EG befindet.
- Svenska: Härmed intygar STAR MICRONICS CO.,LTD. att denna Wireless Device står i
[Swedish] överensstämmelse med de väsentliga egenskapskrav och övriga relevanta bestämmelser som framgår av direktiv 1999/5/EG
- Español: Por medio de la presente STAR MICRONICS CO.,LTD. declara que el Wireless Device
[Spanish] cumple con los requisitos esenciales y cualesquiera otras disposiciones aplicables o exigibles de la Directiva 1999/5/CE.

Português: [Portuguese]	STAR MICRONICS CO.,LTD. declara que este Wireless Device está conforme com os requisitos essenciais e outras disposições da Directiva 1999/5/CE.
Français: [French]	Par la présente STAR MICRONICS CO.,LTD. déclare que l' appareil Wireless Device est conforme aux exigences essentielles et aux autres dispositions pertinentes de la directive 1999/5/CE.
Suomi: [Finnish]	STAR MICRONICS CO.,LTD. vakuuttaa täten että Wireless Device tyyppinen laite on direktiivin 1999/5/EY oleellisten vaatimusten jäsitä koskevien direktiivin muiden ehtojen mukainen.
Italiano: [Italian]	Con la presente STAR MICRONICS CO.,LTD. dichiara che questo Wireless Device è conforme ai requisiti essenziali ed alle altre disposizioni pertinenti stabilite dalla direttiva 1999/5/CE.
Dansk: Nederlands: Nederlands: [Dutch]	Undertegnede STAR MICRONICS CO.,LTD. erklærer herved, at følgende udstyr Wireless Device overholder de væsentlige krav og øvrige relevante krav i direktiv 1999/5/EF. Hierbij verklaart STAR MICRONICS CO.,LTD. dat het toestel Wireless Device in overeenstemming is met de essentiële eisen en de andere relevante bepalingen van richtlijn 1999/5/EG
Eesti: [Estonian]	Käesolevaga kinnitab STAR MICRONICS CO.,LTD. seadme Wireless Device vastavust direktiivi 1999/5/EÜ põhinõuetele ja nimetatud direktiivist tulenevatele teistele asjakohastele sätetele.
Ελληνική: [Greek]	ΜΕ ΤΗΝ ΠΑΡΟΤΣΑ STAR MICRONICS CO.,LTD. ΔΗΛΩΝΕΙ ΟΤΙ Wireless Device ΣΥΜΜΟΡΦΩΝΕΤΑΙ ΠΡΟΣ ΤΙΣ ΟΤΣΙΩΔΕΙ ΣΑΠΑΙΤΗΣΕΙΣ ΚΑΙ ΤΙΣ ΛΟΙΠΕΣ ΣΧΕΤΙΚΕΣ ΔΙΑΤΑΞΕΙΣ ΤΗΣ ΟΔΗΓΙΑΣ 1999/5/ΕΚ.
Slovensky: [Slovak]	STAR MICRONICS CO.,LTD. týmto vyhlasuje, že Wireless Device spĺňa základné požiadavky a všetky príslušné ustanovenia Smernice 1999/5/ES.
Slovensko: [Slovenian]	STAR MICRONICS CO.,LTD. izjavlja, da je ta Wireless Device v skladu z bistvenimi zahtevami in ostalimi relevantnimi določili direktive 1999/5/ES.
Česky: [Czech]	STAR MICRONICS CO.,LTD. tímto prohlašuje, že tento Wireless Device je ve shodě se základními požadavky a dalšími příslušnými ustanoveními smernice 1999/5/ES.
Magyar: [Hungarian]	Alulírott, STAR MICRONICS CO.,LTD. nyilatkozom, hogy a Wireless Device megfelel a vonatkozó alapvető követelményeknek és az 1999/5/EC irányelv egyéb előírásainak.
Български: [Bulgarian]	това Безжично устройство е в съответствие със задължителните изисквания и другите приложения разпоредби на Директива 1999/5/EC.
Polski:	Niniejszym STAR MICRONICS CO.,LTD. oświadcza, że Wireless Device jest zgodny z

[Polish]	zasadniczymi wymogami oraz pozostałymi stosownymi postanowieniami Dyrektywy 1999/5/EC.
Malti:	Hawnhekk, STAR MICRONICS CO.,LTD., jiddikjara li dan Wireless Device jikkonforma mal-
[Maltese]	ħtiġijiet essenzjali u ma provvedimenti oħrajn relevanti li hemm fid-Dirrettiva 1999/5/EC.
Latviski:	Ar šo STAR MICRONICS CO.,LTD. deklarē, ka Wireless Device atbilst Direktīvas 1999/5/EK
[Latvian]	būtiskajām prasībām un citiem ar to saistītajiem noteikumiem.
Lietuvių :	Šiuo STAR MICRONICS CO.,LTD. deklaruoja, kad šis Wireless Device atitinka esminius
[Lithuanian]	reikalavimus ir kitas 1999/5/EB Direktyvos nuostatas.
Norsk:	STAR MICRONICS CO.,LTD. erklærer herved at utstyret Wireless Device er i samsvar med
[Norwegian]	de grunnleggende krav og øvrige relevante krav i direktiv 1999/5/EF.
Íslenska:	Hér með lýsir STAR MICRONICS CO.,LTD. yfi því að Wireless Device er í samræmi við
[Icelandic]	grunnkröfur og aðrar kröfur, sem gerðar eru í tilskipun 1999/5/EC.

This is a class B product. In a domestic environment, this product may cause radio interference, in which case the user may be required to take adequate measures.

Notice: This device can be operated in all European countries.

France: Outdoor use limited to 10 mW e.i.r.p. within the band 2454-2483.5 MHz.
(The wireless output power of this printer is less than 10mW e.i.r.p.)

Italy: For private use, a general authorisation is required if WAS/RLAN's are used outside own premises. For public use, a general authorisation is required.

Norway: This subsection does not apply for the geographical area within a radius of 20 km from the centre of Ny-Ålesund.



“Made for iPod”, “Made for iPhone”, “Made for iPad” mean that an electronic accessory has been designed to connect specially to iPod, iPhone and iPad, respectively, and has been certified by the developer to meet Apple performance standards.

Apple is not responsible for the operation of this device or its compliance with safety and regulatory standards.

iPod is a trademark of Apple Inc., registered in the U.S. and other countries.

iPod touch is a trademark of Apple Inc. iPhone is a trademark of Apple Inc. iPad is a trademark of Apple Inc.

Trademark acknowledgments

SM-L204: Star Micronics Co., Ltd.

Notice

- All rights reserved. Reproduction of any part of this manual in any form whatsoever, without STAR's express permission is forbidden.
- The contents of this manual are subject to change without notice.
- All efforts have been made to ensure the accuracy of the contents of this manual at the time of going to press. However, should any errors be detected, STAR would greatly appreciate being informed of them.
- The above notwithstanding, STAR can assume no responsibility for any errors in this manual.

Caution Symbol



This symbol is placed near the thermal head to indicate that it may be hot.
Never touch the thermal head immediately after the printer has been used.



This symbol is placed near the thermal head to indicate that it is easily damaged. Observe the precautions for handling electrostatic sensitive devices.

Safety Precautions

Please be sure to read

To use this product in safety, please follow the precautions given below.

WARNING

- If you notice smoke, a strange smell, or a strange sound, turn off the power immediately, and remove the battery pack. Then contact the dealer.
- If any foreign material (metal scraps, water, or other fluid) enters the printer, immediately turn off the printer and remove the USB cable and/or battery pack. Then, contact your dealer for advice. Continued use of the printer could result in a fire.
- Never attempt to repair the printer yourself. Also do not disassemble or modify the product. Doing so could lead to injury, fire, or electric shock.
- Do not touch the tear bar.
 - ① There is a tear bar inside the paper outlet slot. Not only should you not put your hand in the paper outlet slot while printing is in progress, never put your hand into the outlet even when printing is not in progress.
 - ② The printer cover can be opened when replacing the paper. However, since the tear bar is on the inside of the printer cover, be careful not to place your face or hands too close to the tear bar.
- During and immediately after printing, the area around the thermal head is very hot. Do not touch it, as you could be burned.
- If any battery fluid gets on your skin or clothing, immediately wash the affected area with fresh water. Otherwise, skin damage may result.
- The battery pack may be hot immediately after the product has been used.

■ Using the Printer

- Some semiconductors can be damaged by static electricity. Be sure to turn off the printer when inserting or removing the battery pack.
- Do not drop the printer or hit it against a hard object.

- Do not open the printer cover while the printer is printing.
- Before you open the printer cover, make sure that printing data is not being sent to the printer.
- Do not unplug or plug in a USB cable while the printer is printing or during communication.
- Do not touch a USB connector while the printer is printing.
- Turn off the printer when you are not using it.
- When the printer is used in a low temperature environment, the battery's performance will be diminished, and the amount of time that you can use the printer for may be reduced.
- Do not pull out paper while the printer cover is closed.
- The heating element and the driver IC of the thermal head are easily damaged. Do not touch them with metal objects, sandpaper, etc.
- Printing quality may suffer if the thermal head heating element becomes soiled by being touched with your hands. Do not touch the thermal head heating element.
- There is a risk of damage to the driver IC of the thermal head from static electricity. Never directly touch the IC.
- Do not operate the printer if there is moisture on the front surface of the head from condensation, etc.

■ **Thermal Paper Handling**

- Only use thermal paper with the designated specifications. The printing quality and working life of the thermal head cannot be guaranteed if any paper other than that recommended is used. In particular, paper containing [Na+, K+, C1-] may drastically reduce the working life of the thermal head. Please exercise caution.
- Store the thermal paper in a cool, dry, dark location.
- Do not rub the thermal paper with a hard object.
- Do not leave the thermal paper in contact with plastic film, an eraser, or adhesive tape for a long period of time.
- Do not stack the thermal paper on fresh diazo copies or wet-type copies.
- Do not use chemical glue on the thermal paper.
- Do not use thermal paper that has been stored for a long period of time.

■ **Operating Environment for the Printer**

Before actually unpacking the printer, you should take a few minutes to think about where you plan to use it. Remember the following points when doing this.

- Do not use the printer in an environment in which it will be subject to strong shaking while it is printing.
- Be careful to ensure that the printer is not exposed to direct sunlight. The appropriate environment for using the printer is described below.

Temperature: 0°C to 40°C

Humidity: 20% RH to 85% RH (no condensation)

- Do not place the printer near a copying machine or other device that produces a strong electromagnetic field.
- Keep the printer sufficiently removed from heaters and other sources of heat.
- Use the printer in a clean, low-humidity environment that is free from dust.
- Avoid using the printer in high-humidity rooms.

■ **Printer Maintenance**

Please perform the following maintenance every 6 months.

- **Thermal head**
Dip a cotton swab in an alcohol solvent (ethanol, methanol, or isopropyl alcohol), and clean the heating area of the head.
- **Platen**
While turning the platen, use a soft dry cloth to lightly rub the entire surface of the platen and remove any foreign objects.
- **Paper storage unit and the surrounding area**
Remove any dirt, dust, pieces of paper, etc., from the paper storage unit.
- **Card reader**
Regularly blow air onto the card reader to remove any dust from the card slot.

■ **Using a Magnetic Card**

- Do not bring magnets near the card, and do not store the card near a device that produces a magnetic field (such as a mobile phone, speaker, or TV). If you do so, the data on the card may be deleted.
- Do not leave the card in a high-temperature environment (such as the dashboard of a car). If you do so, the card may bend.
- Do not touch the card with dirty or wet hands. Also, do not attach adhesive tape or glue to the card. Failing to follow the above precautions could cause the card to stop working properly.

CONTENTS

Chapter 1 Brief Introduction.....	1
1.1 Appearance.....	1
1.2 Printer & Accessories.....	2
1.3 Product Overview.....	3
Chapter 2 Specifications.....	4
2.1 General specification.....	4
2.2 Dimensions.....	6
2.3 Paper.....	7
2.3.1 Paper specification.....	7
2.3.2 Recommended paper.....	7
2.3 Printing range.....	7
2.4 Specification of black mark.....	8
2.5 Code page.....	10
Chapter 3 Operation Methods.....	12
3.1 Preparation before using.....	12
3.1.1 Battery pack installation.....	12
3.1.2 Paper loading.....	12
3.2 Basic Function.....	13
3.2.1 Printer on.....	13
3.2.2 Printer off.....	13
3.2.3 Self-test.....	13
3.2.4 Paper feeding.....	14
3.2.5 Battery Charging.....	14
3.3 Bluetooth.....	17
3.4 Parameter setting.....	18
3.4.1 Menu Operating.....	18
3.4.2 Descriptions with each icon.....	19
3.5 Magnetic card operation.....	21
3.5.1 Magnetic Card.....	21
3.5.2 Magnetic Card Operation.....	23
3.6 Belt Clip Usage.....	24
3.7 OLED panels and LED lamp and Buzzer definition.....	24
3.7.1 OLED description.....	24
3.7.2 LED description.....	24

3.7.3 Buzzer description.....	25
3.8 Instruction for Sleep Mode.....	25
3.9 Usage of STAR Utility.....	25
Chapter 4 Interface.....	31
4.1 USB 2.0 Full Speed interface.....	31
Chapter 5 Trouble shooting.....	32
Annex1.....	35

This manual supports the following firmware version.

Firmware Version	Ver.1.01.02
------------------	-------------

Refer to the appropriate manual which supports the firmware version of you printer.

The firmware version can be confirmed by the self-test.(Refer to 3.2.3 Self-test)

Chapter 1 Brief Introduction

1.1 Appearance

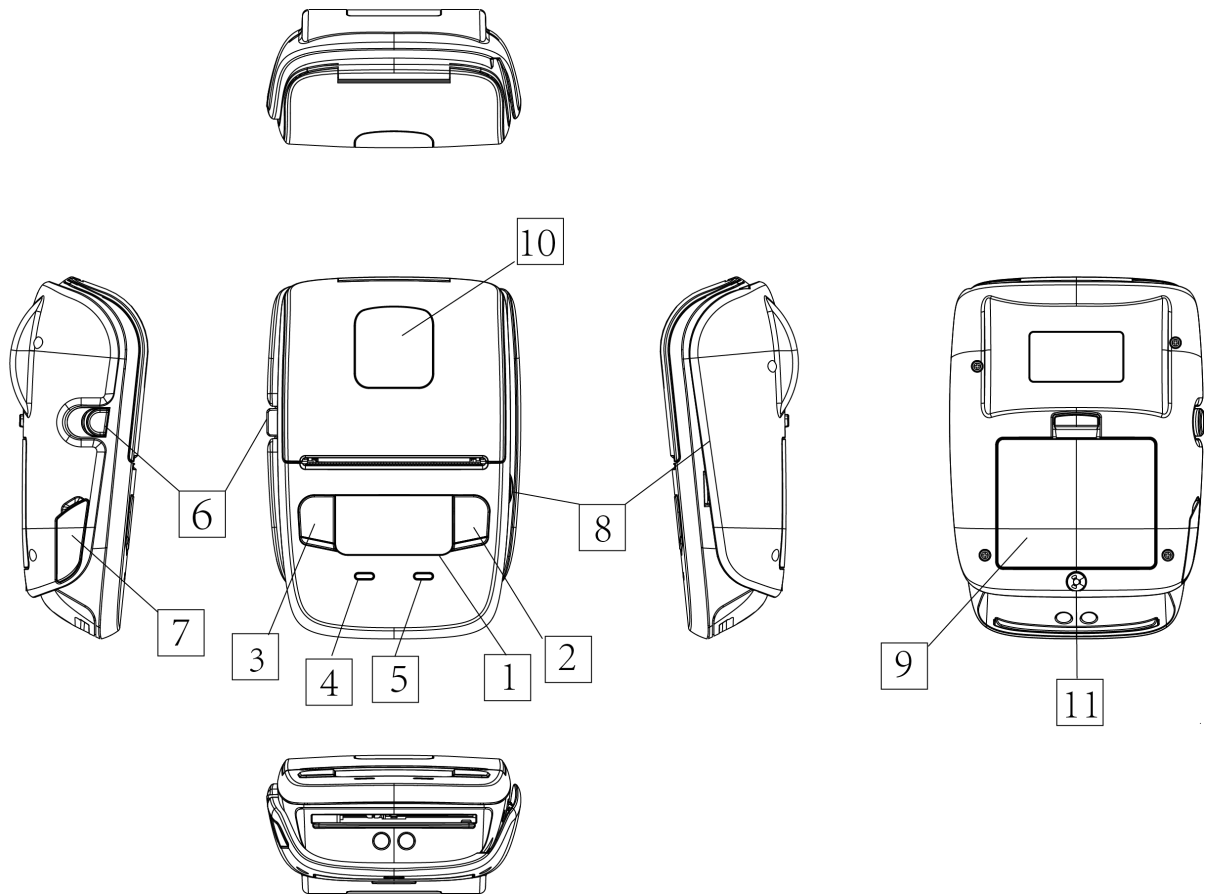

1.OLED Panels	7.USB Interface
2.[FEED] Button	8.Magnetic Stripe Reader (MSR mounting model)
3.[MODE] Button	9.Battery Pack
4.Green [POWER] Lamp	10.Paper Roll Perspective Window
5.Blue [ERROR] Lamp	11.Belt Strap Hole
6.Cover Open Button	

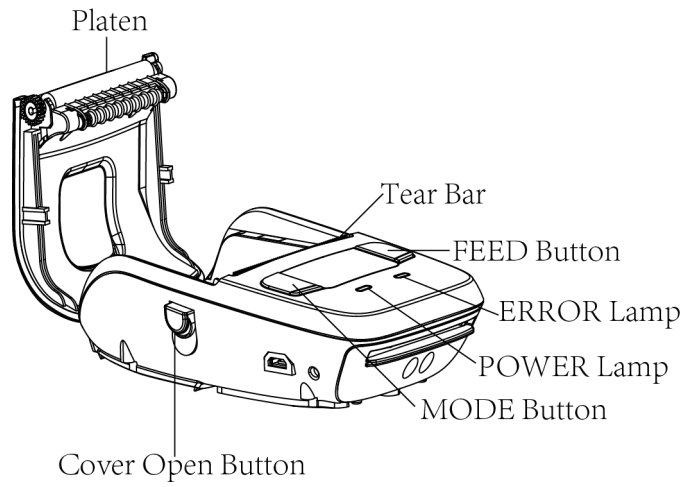

1.2 Printer & Accessories

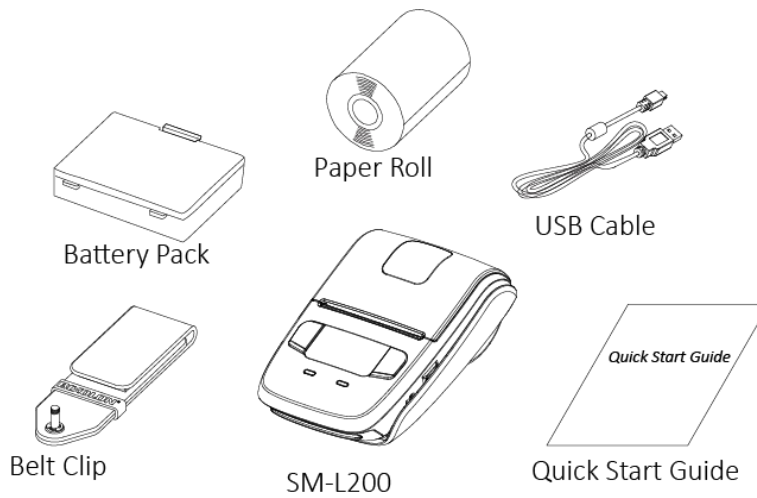

Optional Accessories



1.3 Product Overview

This printer is perfect for mobile banking systems, retail, POS (point of sale) terminals and other forms of mobile computing.

The characteristics of this printer are listed below:

- Pocket size (83 × 122.5 × 44mm)
- Extremely light and mobile (220g including Battery pack)
- Ultra-long standby time(20h) and continuously work for 1.2 hours
- 1.2m Drop Resistance (Tough Rubber Type Case Design)
 - *Our test procedure, Not guarantee
- Very silent printing thru direct thermal printing method
- Print speed 30mm/s (Paper feed 70mm/s)
- Standard-equipped dual interface(USB and Bluetooth Ver3.0/4.0[BLE] Dual Mode)
- Support Magnetic Stripe Reader <Model with Card Reader>
- Support Graphic FSTN(128 × 64 dots) with Blue Backlight
- Belt Clip as a standard accessory
- Support text and graphic printing
- Drop-in design that makes it easy to load paper
- A printer cover that can be opened with the touch of a button
- Printer cover open sensor, Paper-out sensor and Black mark sensor

Chapter 2 Specifications

2.1 General specification

Table 2-1 General specification

(1/2)

Item		Parameter	
Printing	Printing method	Thermal line printing	
	Resolution	203dpi (8dots/mm)	
	Printing speed	70mm/s (Max.)	
	Valid printing width	48mm (384dots)	
Interface	Bluetooth	Bluetooth Spec	Bluetooth Ver 3.0/4.0 [BLE] Dual Mode
		Frequency range	2.4GHz ISM band
		Data transmission rate	115200bps adjustable
		Data bit	8 data bit fixed
		Parity bit	No parity fixed
		Stop bit	1 stop bit fixed
		SSP	Compatible
	USB 2.0 Full Speed		
Power saving	Sleep mode	YES	
Character Set	Font	Alphanumeric: 9x17, 9x24, 12x24 dots Kanji:24x24 dots	
Barcode Symbologies	1D	UPC-A, UPC-E, EAN8, EAN13, CODE39, ITF, CODE128, CODE93	
	2D	QR code,PDF417	
Graphics		Support bitmap printing with different density and user defined bitmap printing (Max. 512K for total)	
Detection	Sensors	Printer cover open sensor, Paper-out sensor and Black mark sensor	
LED lamp	Power lamp	Green	
	Error lamp	Blue	

Table 2-1 General specification(Continued)
(2/2)

Item		Parameter
Charging	USB charge Output DC 5V $\text{---} = 0.5\text{A}$, Time required for full charge:5H	
Power supply	Battery	1700mA 3.7V rechargeable battery pack
	Battery operating time	Approximately 12 hour printing (12 receipts per hour) Approximately 12.5 hour printing (12 receipts per hour with sleep mode)
FSTN		128 x 64 dots with Blue Backlight
Paper	Paper type	Thermal paper
	Paper width	$57.5 \pm 0.5\text{mm}$
	Paper thickness	$0.053\text{mm} \leq X \leq 0.12\text{mm}$
	Roll paper diameter	$13\text{mm} \leq \varnothing \leq 40.5\text{mm}$
	Recommended paper	P220AG,FD200,Alpha 400-2.1
Physical characteristics	Operation condition	0°C to 40°C , 20% to 85%RH
	Storage condition	-20°C to 70°C, 5% to 95%RH
	Dimension	83(W) x 122.5(D) x 44(H) mm
	Weight	220g (including battery pack)
Reliability	TPH	50km(not more than 12.5% printing density)/100 million pulses
Software	Emulation	StarLine mode

 **WARNING:**

Pls.use the recommended thermal paper or same quality paper, otherwise it will influence the printing quality and decrease the thermal print head life.

2.2 Dimensions

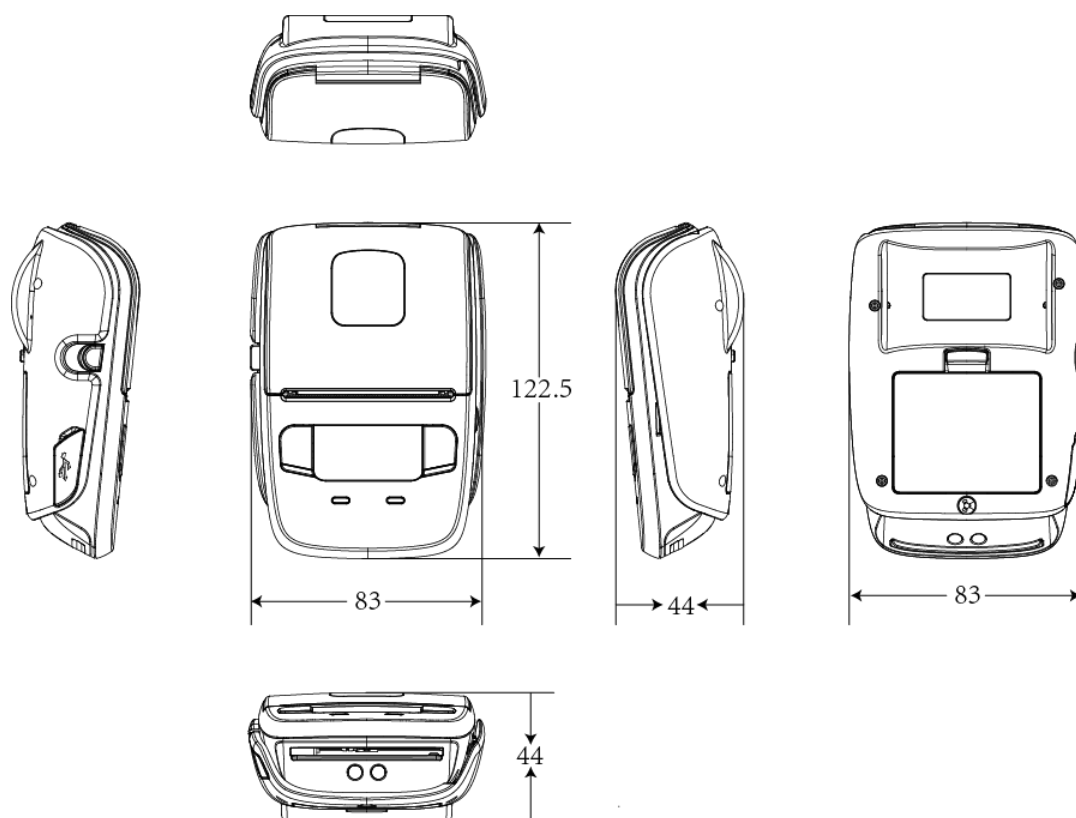

- External Dimension :83mm (W) x 122.5mm (D) x 44mm (H)
- Weight : 220g (including battery pack)
- Body color :Black

2.3 Paper

2.3.1 Paper specification

Paper type	Thermal paper
Paper width	58mm
Paper thickness	0.053mm≤X ≤0.12mm
Roll paper diameter	13mm≤∅≤40.5mm

2.3.2 Recommended paper

Manufacturer	Product Name
Mitsubishi Paper Mills Limited	P220AG
Oji Paper Co., Ltd.	PD450
APPLETON	Alpha 800-2.4
KANZAKI (Oji Paper USA)	P-350

2.3 Printing range

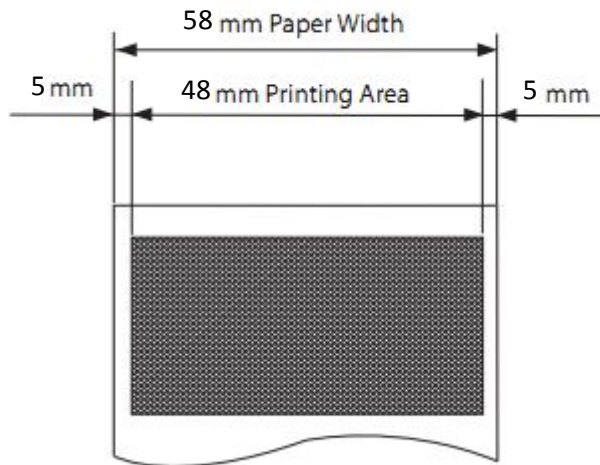

CAUTION

- 1) Do not use roll paper whose end is glued to its core, because the printer will be unable to properly detect the end of the paper. Also, we recommend that you use roll paper that has a roll end mark at its end.
- 2) Chemicals and oil may cause the roll paper to change color or cause the printed characters to become lighter.
- 3) Please be aware that the roll paper can be affected by heat, humidity, and direct sunlight.
- 4) The roll paper may change color if you scratch it with your fingernail, a hard piece of metal, etc.

2.4 Specification of black mark

● Thermal paper

SM-L204 supports black mark on both sides of the paper and the specification of black mark is illustrated by the following image.

Unit:mm

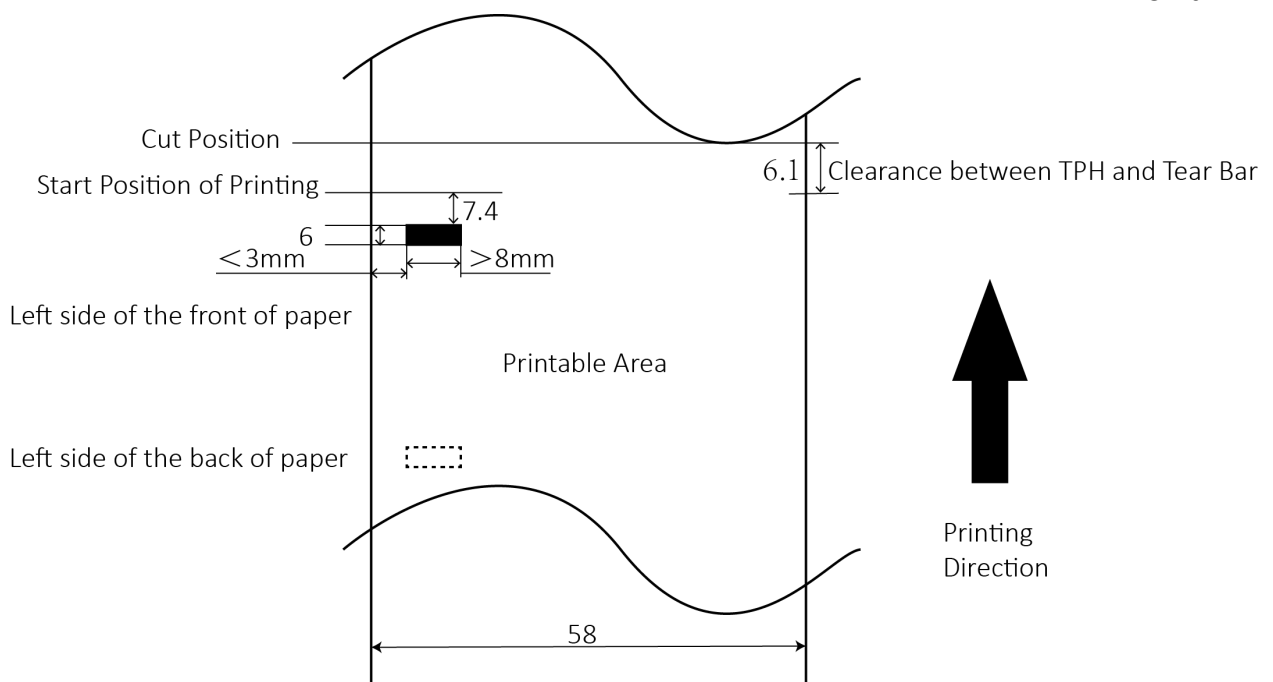

Note:PCS value of BM should be more than 0.9

● Label paper

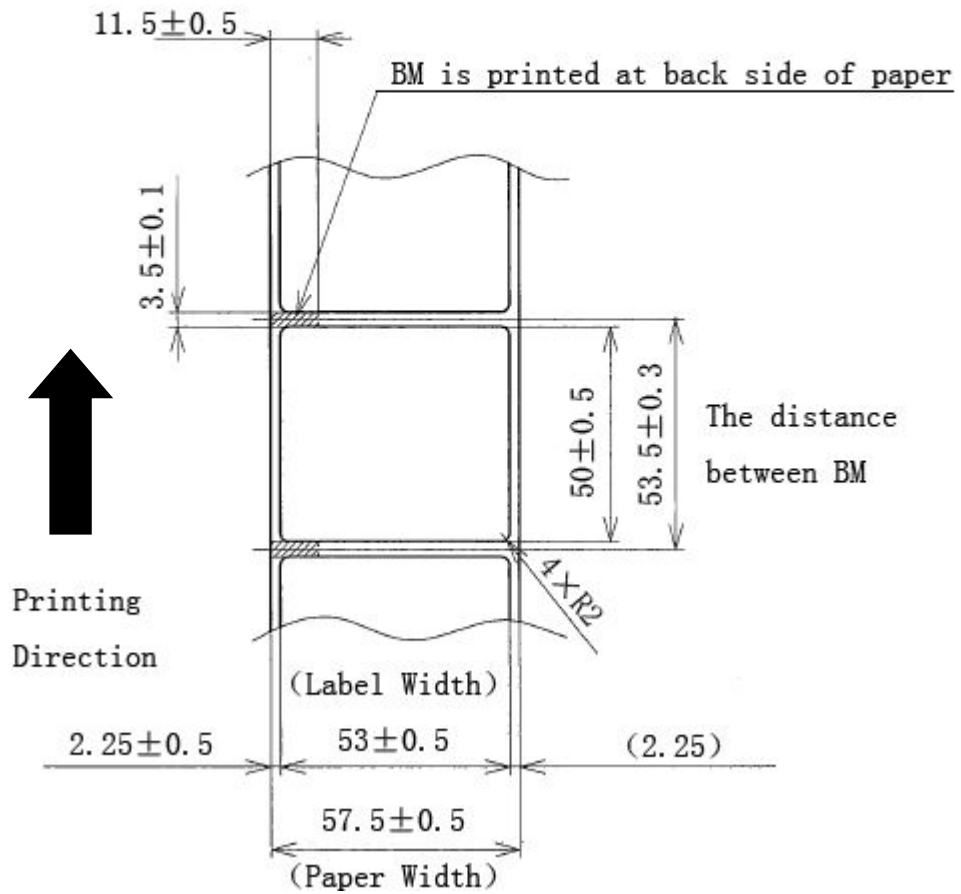

Note: PCS value of BM should be more than 0.9

2.5 Code page

Table 2-5 Code page

(1/2)

Code page
Page 0, Normal is selected.
Page 1, CodePage 437 (USA,Std. Europe) is selected.
Page 2, Katakana is selected.
Page 3, CodePage 437 (USA,Std. Europe) is selected.
Page 4, Codepage 858 (Multilingual) is selected.
Page 5, Codepage 852 (Latin-2) is selected.
Page 6, Codepage 860 (Portuguese) is selected.
Page 7, Codepage 861 (Icelandic) is selected.
Page 8, Codepage 863 (Canadian French) is selected.
Page 9, Codepage 865 (Nordic) is selected.
Page 10, Codepage 866 (Cyrillic Russian) is selected.
Page 11, Codepage 855 (Cyrillic Bulgarian) is selected.
Page 12, Codepage 857 (Turkey) is selected.
Page 13, Codepage 862 (Israel (Hebrew)) is selected.
Page 14, Codepage 864 (Arabic) is selected.
Page 15, Codepage 737 (Greek) is selected.
Page 16, Codepage 851 (Greek) is selected.
Page 17, Codepage 869 (Greek) is selected.
Page 18, Codepage 928 (Greek) is selected.
Page 19, Codepage 772 (Lithuanian) is selected.
Page 20, Codepage 774 (Lithuanian) is selected.
Page 21, Codepage 874 (Thai) is selected.
Page 32, Codepage 1252 (Windows Latin-1) is selected.

Table 2-5 Code page(Continued)
(2/2)

Code page
Page 33, Codepage 1250 (Windows Latin-2) is selected.
Page 34, Codepage 1251 (Windows Cyrillic) is selected.
Page 64, Codepage 3840 (IBM-Russian) is selected.
Page 65, Codepage 3841 (Gost) is selected.
Page 66, Codepage 3843 (Polish) is selected.
Page 67, Codepage 3844 (CS2) is selected.
Page 68, Codepage 3845 (Hungarian) is selected.
Page 69, Codepage 3846 (Turkish) is selected.
Page 70, Codepage 3847 (Brazil-ABNT) is selected.
Page 71, Codepage 3848 (Brazil-) is selected.
Page 72, Codepage 1001 (Arabic) is selected.
Page 73, Codepage 2001 (Lithuanian-KBL) is selected.
Page 74, Codepage 3001 (Estonian-1) is selected.
Page 75, Codepage 3002 (Estonian-2) is selected.
Page 76, Codepage 3011 (Latvian-1) is selected.
Page 77, Codepage 3012 (Latvian-2) is selected.
Page 78, Codepage 3021 (Bulgarian) is selected.
Page 79, Codepage 3041 (Maltese) is selected.
Page 96, if current font is not Font-C, Thai Character Code 42 (Thai) is selected.
Page 97, if current font is not Font-C, Thai Character Code 11 (Thai) is selected.
Page 98, if current font is not Font-C, Thai Character Code 13 (Thai) is selected.
Page 99, if current font is not Font-C, Thai Character Code 14 (Thai) is selected.
Page 100, if current font is not Font-C, Thai Character Code 16 (Thai) is selected.
Page 101, if current font is not Font-C, Thai Character Code 17 (Thai) is selected.
Page 102, if current font is not Font-C, Thai Character Code 18 (Thai) is selected.

Note: Please refer to SM-L204 Programming Manual

Chapter 3 Operation Methods

3.1 Preparation before using

3.1.1 Battery pack installation

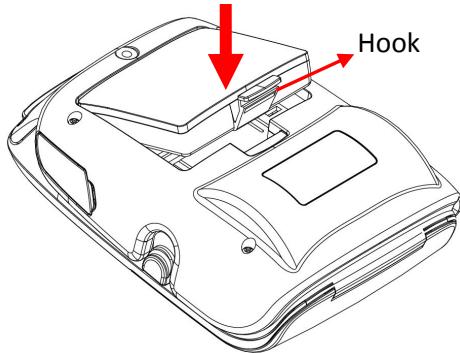

1. Make sure that the printer has been turned off before you insert or remove the battery pack.
2. Push the battery into the slot until a snapping sound is heard.
3. Pull back the hook and remove the battery pack, following the direction of the arrow.

3.1.2 Paper loading

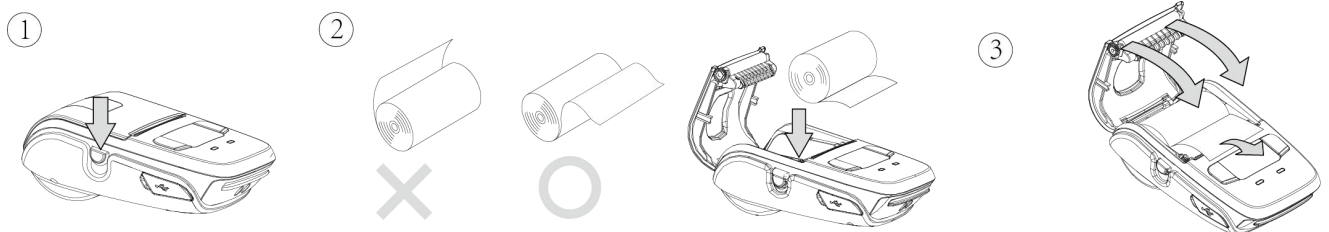

Operation methods:

- 1) Press the cover open button to open the paper cover.
- 2) Load the roll paper in the orientation shown in the figure above, and then pull the end of the roll straight toward you.
- 3) Close the top cover. Press down on both sides of the printer cover to close it firmly. When you close the printer cover, make sure that it is closed on both sides.
- 4) Use the tear bar to cut the extra paper.

CAUTION

When ERROR lamp is flashing, please make sure the cover is closed correctly. If it's not, open the cover and close it correctly. When the paper is jammed, be sure to open the printer cover before removing the jammed paper. Do not under any circumstances try to pull out the jammed paper forcefully while the printer cover is closed, Doing so may damage parts of the printer.

3.2 Basic Function

3.2.1 Printer on

The printer is powered on by pressing the **【MODE】** button for about 2 seconds;

3.2.2 Printer off

The printer is off after hold down the **【MODE】** button for about 2 seconds. All the lamps and OLED panels are off whenever the printer is off.

3.2.3 Self-test

You can use a self test to check the printer's settings.

Before you start the self test, make sure that roll paper has been properly loaded into the printer.

Self-test Procedure:

- 1) Turn on the power while holding down **【FEED】** button.
- 2) The printer will print the current printer status, including the firmware version, and print settings.
- 3) The self test will finish automatically. The printer will be ready to receive data after the self test finishes.

Self-test sample:

```

Model: SM-L200
Firmware:1.01.02 MSR
Build date: Dec 12 2014
Build time: 10:04:52
S/N: XXXXXXXX
BatteryVoltage: 3.91 v

[Bluetooth Configure]
Name: STAR L200-00001
BluetoothID: 8C-DE-52-60-1E-3F
Simple Pairing: Disable

[Install Fonts]
ID Font Name
0 SYSTEM 12x24
24x24 JIS

[ASCII Samples]
!"#$%&'()*+,-./:0123456789;<=>
@ABCDEFGHIJKLMNPQRSTUWXYZ[\]^_
`abcdefghijklmnopqrstuvwxyz{|}~

-- Memory Switch --
FEDCBA9876543210 HEX.
<0> 0000000000000000 8010
<1> 0000000000000000 0000
<2> 0000000000000000 0001
<3> 0000000000000000 0000
<4> 0000000000000000 0040
<7> 0000000000000000 0000
<8> 0000000000000000 0000
<5> 0000000000000000 0078
<7> 0000000000000000 003C

-- Memory Switch Detail--
<0F> = Emulation:Star Line/T
<05> = SHIF-JIS mode:Enable
<04> = Character Mode:JIS
<10>-C= Top Search:Lower Close
<18> = Black Mark:Invalid
<14> = Zero Style:Normal
<13>-0= Inter. Char:USA
<22>-0= Print Density:Medium
<35> = Kanji Pitch:26 dot
<34> = ANK Pitch:12 dot
<30> = Feed Pitch:4 mm
<4D>-0= Black Mark Adjustment:64
dots
<7C> = ASB Function:Invalid
<01>-0= Paper Type:Receipt
<5D>-0= Power Down:120 min
<1D>-0= Sleep Mode:60 s

Selftest Finished.
    
```

3.2.4 Paper feeding

Thermal receipt paper

Press **【FEED】** button and Printer will execute paper feeding until released **【FEED】** button or stop feeding when reaching max feeding distance (200mm).

Black mark paper

Press **【FEED】** button and Printer will stop feeding when it detect the black mark.

NOTE:If the length between mark is set to 0,printer will feed paper ignoring the black mark.

3.2.5 Battery Charging

When battery pack runs out of power, the battery icon will be flashing. It will power off automatically when continues printing. If you want to go on, please charge it.

Charging method:

- ◆ Plug in socket with USB charging

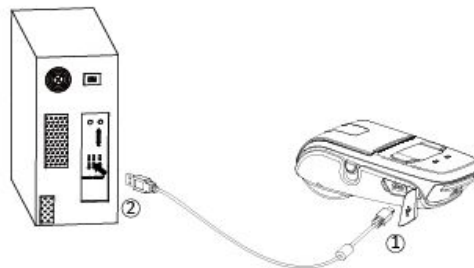

Power-off charging:

- ◆ POWER lamp will always flash in green color and goes off when fully charged.

Power-on charging:

- ◆ POWER lamp will keep flashing in green color, and stop flashing when fully charged.

Charging the printer when it is on,if battery icon on the screen shows fully charged,turn off the printer and let the battery charge until the power lamp shows fully charged.



Notes about the Battery Pack

■ General Battery Characteristics

- The battery is a consumable and its performance over time will gradually decrease.
- While not in use, the battery will slowly discharge itself.

Prepare a battery pack that has been charged relatively recently (1 to 2 days earlier).

- To ensure that the battery lasts for a long time, we recommend that you turn off the printer whenever possible.
- When used at low temperatures, battery performance will temporarily decline. Be sure to have a fully-charged spare battery standing by if the printer will operate in a cold environment.

■ Charging the Battery Pack

- The battery pack can be charged at ambient temperatures between 0 and 40°C.
- The time required to charge the battery pack varies depending on the voltage and the ambient temperature. Normally, it takes 4 to 5 hours to charge the battery pack.
- It will take longer to charge the battery pack if you print while charging the battery pack.
- Do not remove the battery pack while it is being charged.
- Fully charge the battery prior to using the printer. Otherwise, the performance of the battery may be affected.
- There is no need to completely discharge or use up a rechargeable Li-polymer battery before recharging it.
- It is normal for the battery pack to be hot after it has finished charging or been used.
- Do not recharge a battery pack that has just been fully charged.

■ Battery Pack Life

- The battery can be charged approximately 500 times in the normal temperature range without losing performance. If an extreme decline in the running time of the battery is noticed, the battery is reaching the end of its usable life. It is recommended to replace the old battery with a new one.
- When charging, printing is available.

■ Notes about Using the Battery Pack

- Only use a designated battery pack.
- Only use the designated battery charging method.

You cannot use a USB cable other than the designated USB cable.

- Do not throw the battery into a fire, place it near a flame or heating device, or leave it in a hot environment (under direct sunlight, in a car, etc.).
- Do not use a battery pack that has been dropped or subjected to a shock in some other way.
- Do not disassemble or modify the battery pack.
- Do not short the terminals of the battery pack or get it wet.

Do not place the battery pack in a bag with a small metal object (such as a key).

•If any battery fluid gets on your skin or clothing, immediately wash the affected area with fresh water. Otherwise, skin damage may result.

■ Notes about Storing the Battery Pack

•The characteristics of the battery pack may degrade if you store it in a charged state for a long period of time.If you do not intend to use the battery pack for a while, use up its power before storing it.

•If you do not intend to use the battery pack for a long time, be sure to remove it from the printer.

•Keep the battery out of the reach of children. In addition, be careful that children do not remove the battery.

•Store the battery pack in a cool place.

* We recommend that you store the battery pack in a dry area with an ambient temperature of 15 to 25 °C.

* Avoid storing the battery in locations with high or extremely low temperatures.

■ Battery Disposal and Recycling

A battery pack is used to power this device. Since the disposal process of batteries varies from country to country, refer to the appropriate measures mandating the disposal method of the country in which this device is used.

< For U.S.A. and Canada >

	<p>Lithium-Ion batteries are recyclable. You can help preserve our environment by returning your used rechargeable batteries to the collection and recycling location nearest you. For more information regarding recycling of rechargeable batteries,call toll free 1-800-822-8837, or visit http://www.rbrc.org/</p>
-------------------------------------------------------------------------------------	-----------------------------------------------------------------------------------------------------------------------------------------------------------------------------------------------------------------------------------------------------------------------------------------------------------------------------------------------------------

If battery pack is not in use for a long time,please remove it after fully charged.And it should be recharged every 3 months.

When power is low,battery should be charged in time.If the printer automatically power down because of low power,be sure to charge the battery in 15 days.Otherwise,it will cause permanent damage to the battery.

3.3 Bluetooth

PDA with Bluetooth interface, laptop and other information terminals can drive the mobile printer SM-L204. Instructions as follows:

- 1) Power on the printer.(Press and hold POWER button for approx. 2 seconds)
- 2) Master device search for outer Bluetooth devices.
- 3) If there are some outer Bluetooth devices, choose “STAR L200-XXXXX”.
(XXXXX represent the serial number)
- 4) Connected to STAR L200-XXXXX.(The default password is 1234)
- 5) Finish pairing.

Notes:

1.SM-L204 has two Bluetooth modes,with password and without password.It can be set through Star Utility.

2.Password is disable to iOS system

3.In pairing, mobile thermal printer SM-L204 must be turned on.

4.Pairing sets one by one in order, otherwise it can't figure out which one succeeds in pairing.

The Bluetooth® word mark and logos are owned by the Bluetooth SIG,Inc. and any use of such marks by Star is under license.(Design and specifications subject to change without notice.)

3.4 Parameter setting

3.4.1 Menu Operating

1. Press **【MODE】** button for 2 seconds to **turn on the printer**:



2. Press **【MODE】** and **【FEED】** at the same time for about 5 seconds until the printer shows the below image in the display. And release the buttons to enter the menu mode.



3. After entering the menu, printer display will show as below:

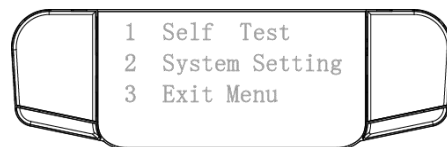

Button operation:

MODE button









User can use MODE button to choose the different menus and adjust parameter(0~9). User can also use MODE button to return to the previous menu.

FEED button

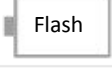
User can use FEED button to move cursor(“_”) back and forth an entry the next menu. User can also use FEED button to confirm the new setting.

First-level menu	Second-level menu	Third-level menu
Self Test	Print	Press Feed To Print
	MSR	Please Swipe Card
	Hex Dump Mode	Hex Dump Mode
System Setting	Density	0-Low 1-Medium 2-High 3-Special
	Standby Time	Standby Time:0060
	Auto Off Time	Power Down Time(Min):0120
	Paper Type	0-Receipt 1-BM(Front) 2-BM(Back)
	Factory Reset	0-Cancel 1-Factory Reset
	Password	Input New Password:0000

3.4.2 Descriptions with each icon

Bluetooth status		Unconnected
		Connected
Battery status		Full four bars of battery
		Low battery
		Charging
Paper status		Receipt paper
		Black Mark Front
		Black Mark Back
		Label gap
		Out of paper

Choose the command set: StarLine or ESC/POS

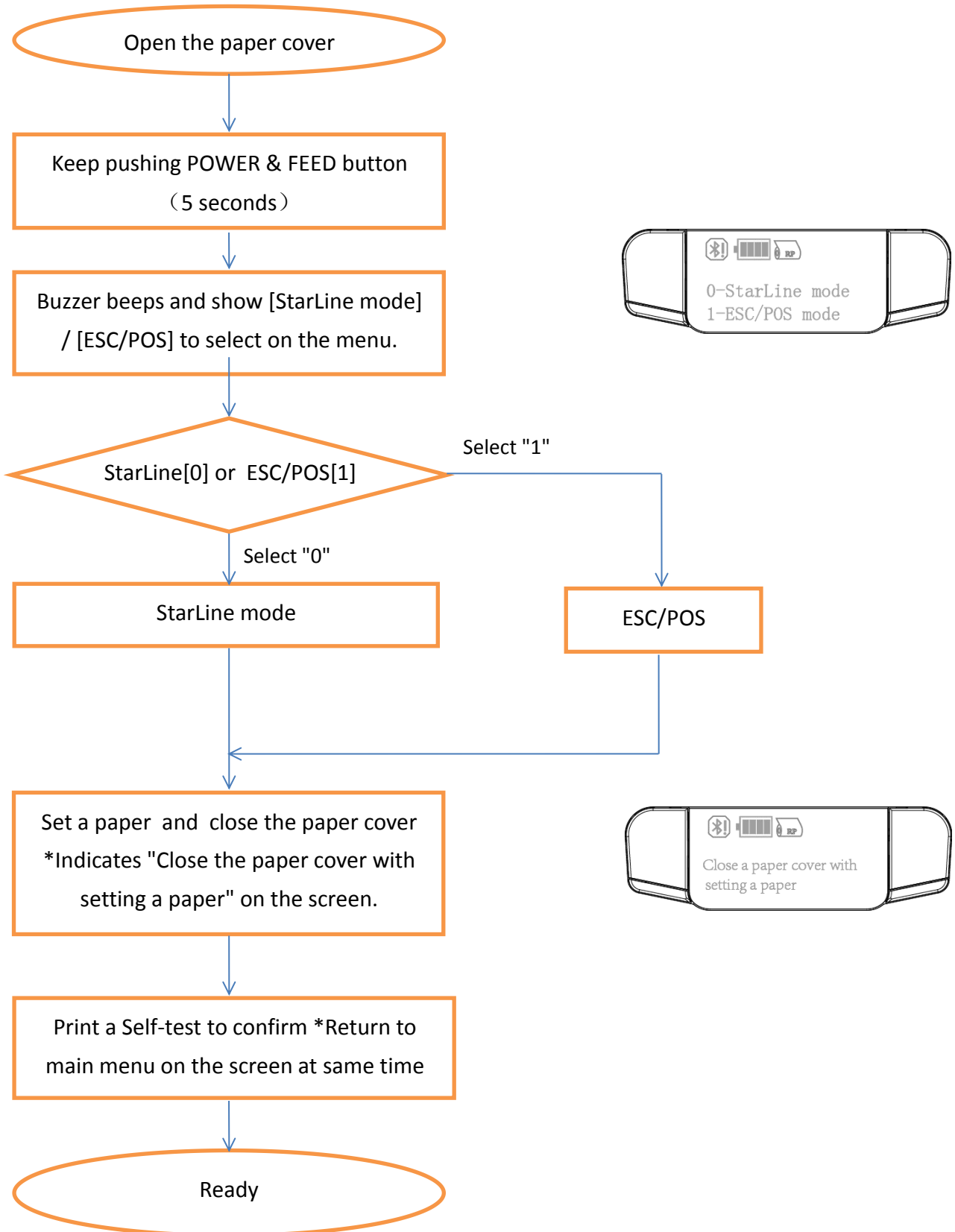

3.5 Magnetic card operation

3.5.1 Magnetic Card

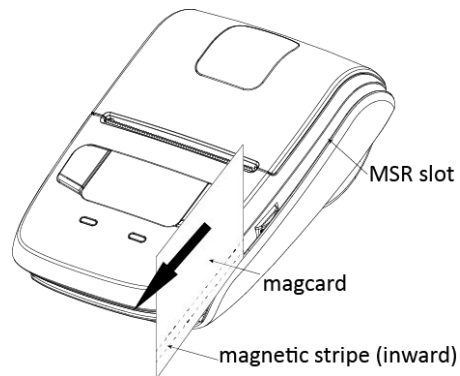

NOTE: Please pay attention to the orientation of the magnetic stripe.

Please keep the following points in mind when reading a card.

- Swipe the card with its magnetic stripe side towards the printer.
- Hold the card in the center as illustrated below and swipe it straight at a steady speed in the directions of arrows. You can swipe the card in either direction to read the data.
- Be sure to hold the printer firmly with your hand while swiping.
- If you hold the corner of the card, it is difficult to swipe it straight so that you may fail to read the card data. So hold the card in the center when you swipe the card.
- A buzzer will sound once when a card is successfully read. When the printer fails to read the card, the buzzer will sound three times. Check the orientation of the card, and slide it through the reader slot again.

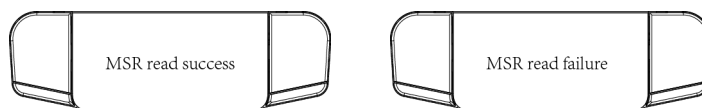

Note:

1. Swiping JIS card is also under MSR mode.

2. JIS card operation is same as MSR card operation.

Correct example:

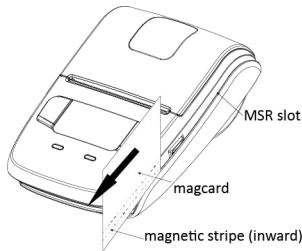

Make sure the magnetic stripe is towards to the magnetic head. Hold the card in the center as illustrated below and swipe it straight at a steady speed in the direction of arrows.

Incorrect example:

To grasp a magnetic card

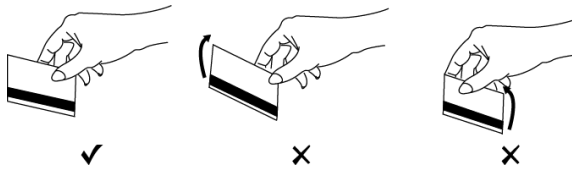

If you grasp the front/rear part of a card and move it through the MSR slot, the front /rear part is loose and a read error occurs.

To move a magnetic card

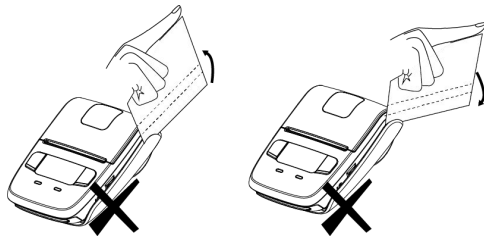

If you insert a card tilted upward/downward into the MSR slot, the card does not move horizontally and a read error occurs.

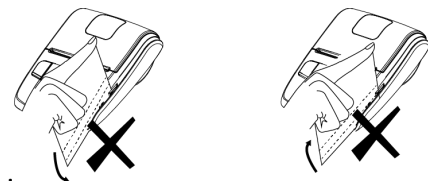

If you extract a card at the end of the MSR slot by lifting up or lowering down, the card is not maintained and a read error occurs.

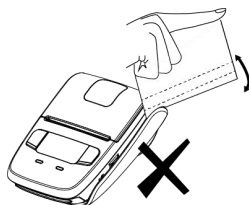

If you insert a card into the middle part of the MSR card, the card is not read correctly and read error occurs, or if you move the card back or forth by force after inserting into the MSR slot, the card is not read correctly and a read error occurs.

3.5.2 Magnetic Card Operation

- **Reading MSR Card Information(No encryption)**

Note:We have two kinds of reading cards modes.Please confirm your MSR/JIS card is No encryption or Encryption.

Set printer in Reading MSR/JIS Card Mode by sending instructions to the printer.Then the backlight of screen is lighted,showing"MSR Mode".It means that printer is in the Reading MSR Card Mode.Then it only need to swipe the card lightly according to the direction shown in the picture above.If it can read the data of corresponding magnetic track successfully,it can transmit the information of magnetic track back to the client.Finally printer quit the Reading MSR Card Mode,back to the Normal Printing Mode.If it can't read the data of corresponding magnetic track successfully,wait for the next swiping.

More detailed operation and data format refer to <<SM-L204 Programming Manual>>.

- **Reading MSR/JIS Card Information(Encryption)**

Note:We have two kinds of reading cards modes.Please confirm your MSR/JIS card is No encryption or Encryption.

Set printer in Reading MSR Card Mode by sending instructions to the printer.Then the backlight of screen is lighted,showing"MSR Mode".It means that printer is in the Reading MSR Card Mode.Then it only need to swipe the card lightly according to the direction shown in the picture above.If it can read the data of corresponding magnetic track successfully,it can transmit the information of magnetic track back to the client.At this time,if users want to quit Reading MSR Card Mode,back to the Normal Printing Mode,they need to send corresponding canceling reading instruction.If it can't read the data of corresponding magnetic track successfully,wait for the next swiping.

More detailed operation and data format refer to <<SM-L204 Programming Manual>>.

Note:Swiping JIS card is also under MSR mode.

3.6 Belt Clip Usage

Follow the procedure below to attach the belt clip to the printer.

- 1) Insert the belt clip screw into the belt clip hole, use a coin to tighten the belt clip screw as shown in the image.
- 2) Undo the belt clip, fasten the belt clip to a belt.
- 3) Close as shown in the image

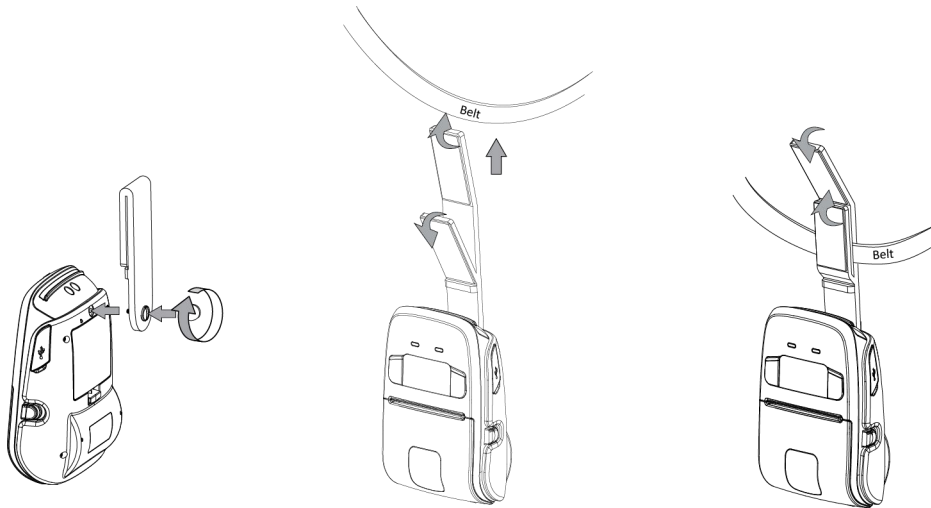

Note: Be careful not to drop when use a belt clip. Velcro be securely fixed.

3.7 OLED panels and LED lamp and Buzzer definition

There are one OLED, one buzzer and two LED lamps to indicate the printer status.

3.7.1 OLED description

See Annex1 for details

3.7.2 LED description

Power lamp (green)	Error lamp (blue)	Status
Flash	OFF	Power-on charging
Flash	OFF	Power-off charging
ON	OFF	Power-on charging , Battery full
OFF	OFF	Power-off charging , Battery full
ON	OFF	Power on
Flash	OFF	Standby
ON	Flash	Paper out
ON	Flash	Cover open

3.7.3 Buzzer description

Buzzer	Status
No ring	Low battery
Once	Begin charging/Press button/Cover close
Twice	Paper out/Cover open
Three	USB disconnected

3.8 Instruction for Sleep Mode

SM-L204 has sleep mode to save power.

If there is no operation in 60 seconds(Default),printer will enter into sleep mode.If the printer is in sleep mode for 120 minutes(Default),it will power down automatically.

You can change the default time in system setting,more details in 3.4.3 Menu Operating.

The printer in the sleep mode will recover to the Print Ready Mode when receiving commands or button operations.

3.9 Usage of STAR Utility



Warning:In different operating system,screen has slight difference.Please

operate according to the tips.

- **Install the “STAR Utility ”**

1)Double click the application”STAR Utility Setup V1.2.0.0.exe”.Click “Next”.

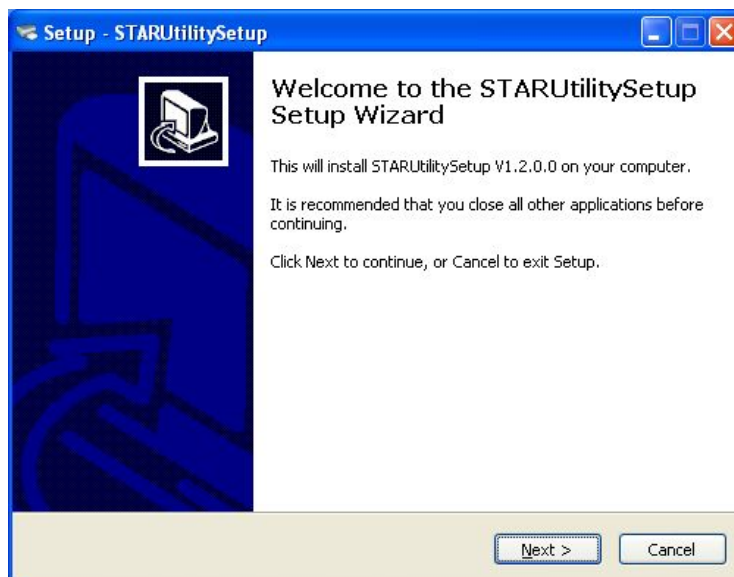

2) Select destination location and click “Next”.

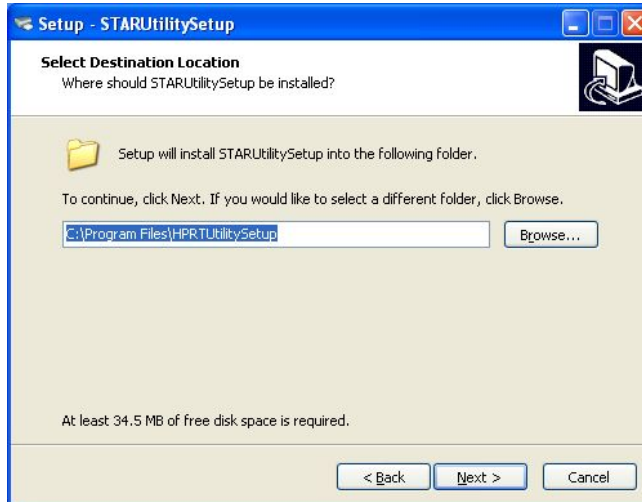

3) Select start menu folder and click “Next”.

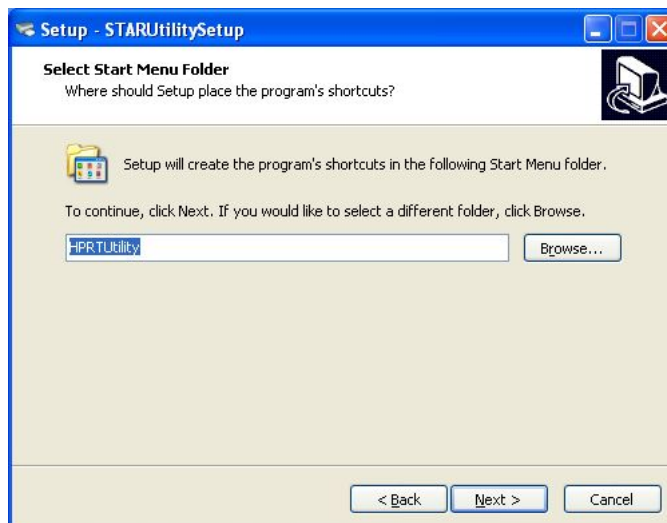

4) Click “install”.

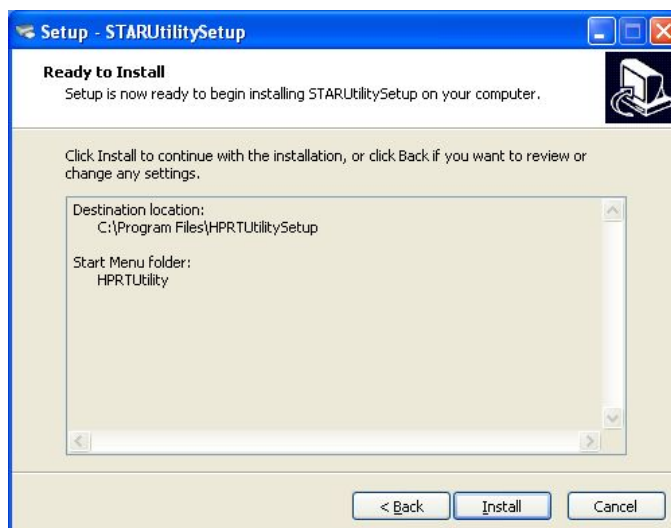

5)Click “Finish” to complete.

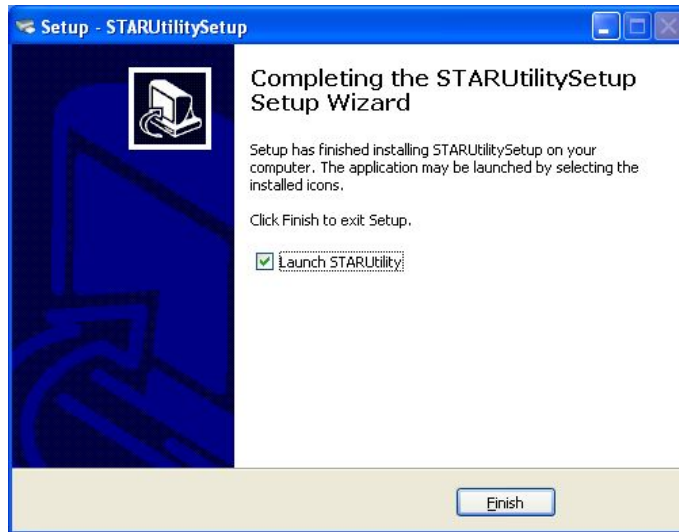

● Set the parameter

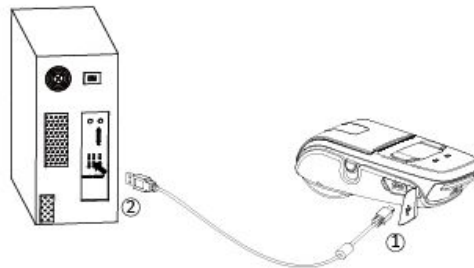

- 1)Use the USB cable to connect SM-L204 and the computer.
- 2)Turn on the SM-L204.
- 3)Double click the “STAR Utility”.
- 4)Click “Connection Test”to test if SM-L204 is connected with computer..

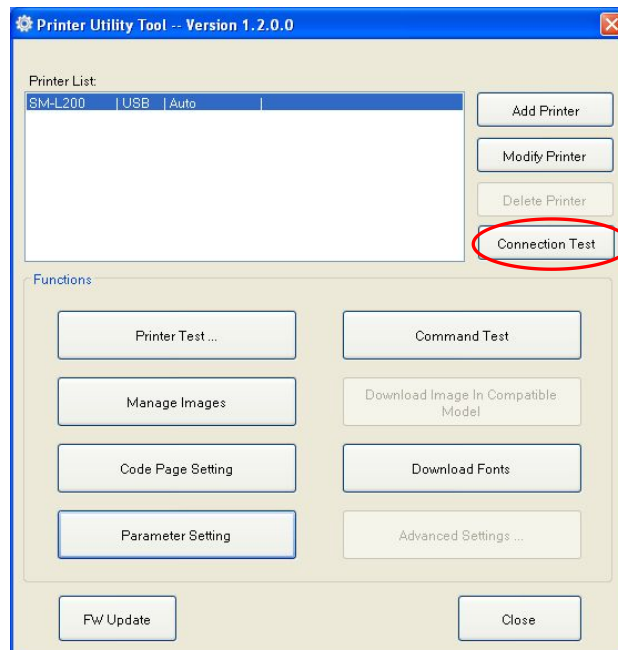

If it is, it will pop up a window like this.



- Printer Test

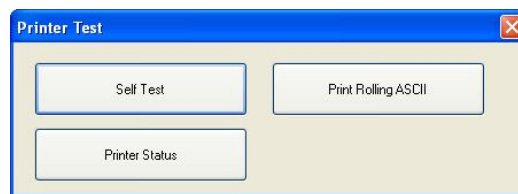

Click "Self Test". Printer will print self test page.

Click "Print Rolling ASCII". Printer will print character test page.

Click "Printer Status". It will show the printer status.

Note: In JIS or Hangle mode, "Print Rolling ASCII" is invalid.

- Command Test

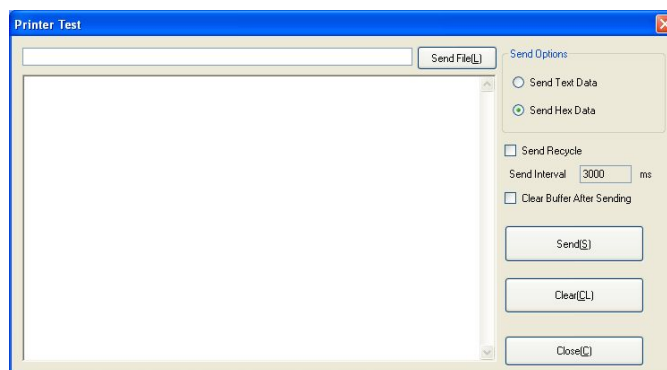

Input the command in the box and click "Send". Printer will execute the corresponding action.

- Manage Images



Click “Download” and select a picture from local folder.Click”Print”.Printer will print the picture.

Note:Each picture should be less than 40Kb.Total space is 256Kb.

- Code Page Setting

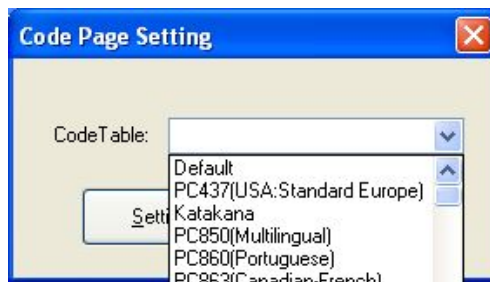

Select the code you need and click”Setting”.

- Download Fonts

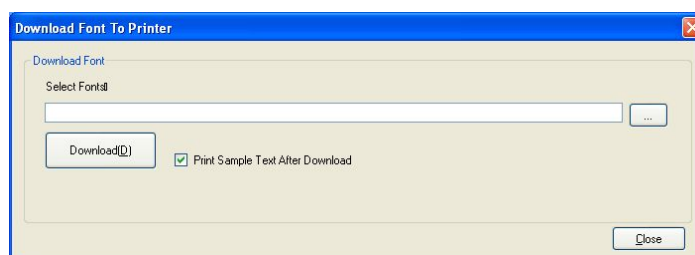

Select the font from local folder.Click “Download” to download the font into printer.

● Parameter Setting

Character Setting

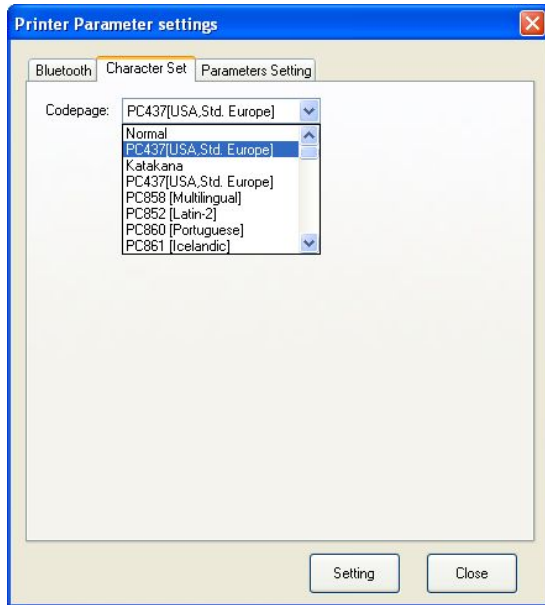

Parameter Setting

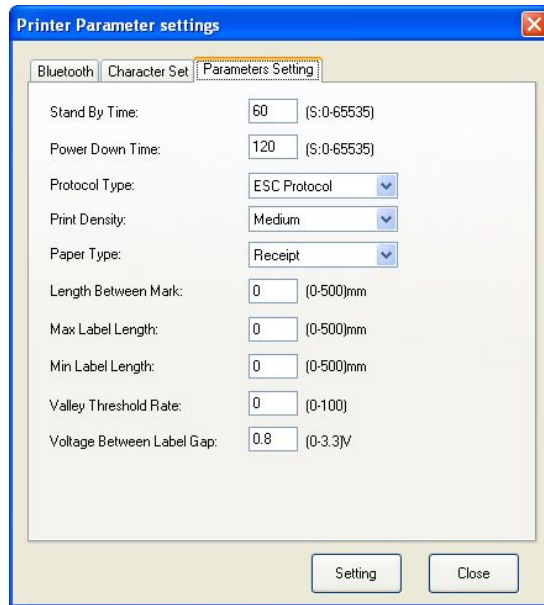

Note:

After click "Setting", printer will automatically power off. Power on the printer. The new setting take effect.

If it's set successfully, it will pop up a window like this.



Chapter 4 Interface

4.1 USB 2.0 Full Speed interface

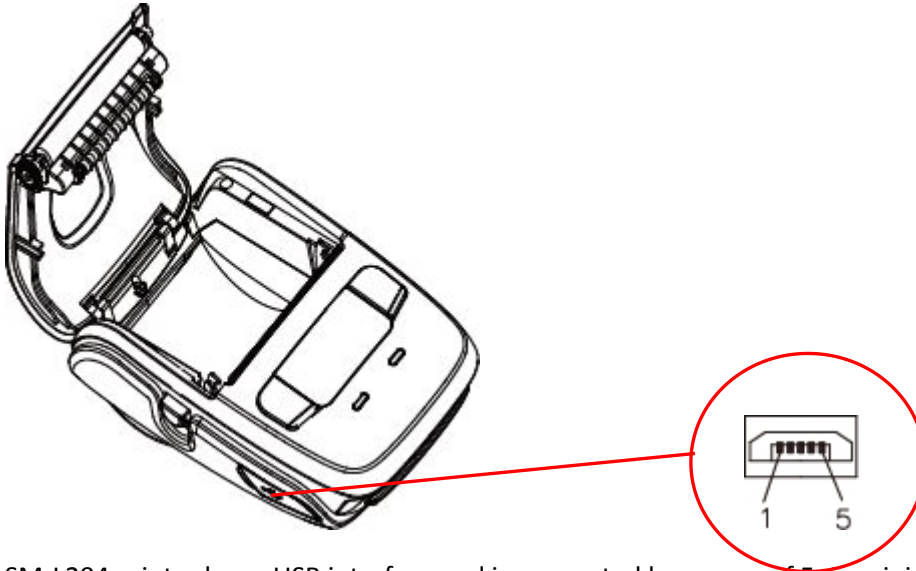

SM-L204 printer has a USB interface and is connected by means of 5pin mini USB socket. In the following table, the signals present on the micro USB socket are listed.

Pin No.	Name
1	VBUS
2	D-
3	D+
4	NC
5	GND

■ USB cable

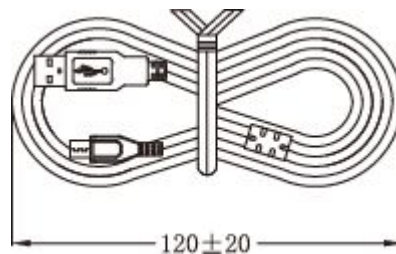

Chapter 5 Trouble shooting

1) Power Supply Failure

Phenomenon	Cause	Check Method	Remedy
No Power (Power indicator not illuminated)	The battery is not connected.		Connect the specified battery.
	The battery is discharged.		Charge the battery

2) Faulty sensor

Phenomenon	Cause	Check Method	Remedy
Does not detect presence of paper.	Faulty paper sensor.	Check whether the ERROR indicator flickers when paper is out.	Replace the mechanism ass'y.
	Foreign substance is attached the paper sensor.	Check whether any foreign substance are adhered to the paper sensor.	Remove the foreign substance.
	Faulty connection of the paper sensor connector.	Check connection of the paper sensor connector.	Connect the connector correctly.

3) Printing Failure

Phenomenon	Cause	Check Method	Remedy
No printing	The paper roll is loaded upside down.		Install the roll paper properly.
	Faulty main PCB Ass'y.		Replace the main logic board ass'y.
	Faulty connection of the thermal head connector.	Check connection of the thermal head connector.	Connect the thermal head connector properly.
	Faulty thermal head.		Replace the mechanism ass'y.
Partly not printed	Faulty connection of the thermal head connector.	Check connection of the thermal head connector.	Connect the thermal head connector properly.
	Faulty thermal head.		Replace the mechanism ass'y.
Faint printout or uneven printout	Level of battery voltage is low.	Check the battery indicator on the OLED.	Charge the battery.
	Faulty thermal head.		Replace the mechanism ass'y.
	Foreign substance is adhered to the thermal head.	Check whether any foreign substance are adhered to the thermal head.	Dip a cotton swab or soft cloth in ethyl alcohol and wipe the foreign substance with them.
	Non-recommended paper is used.	Check whether the paper being used meets the specification.	Replace it with the specified paper.
	Faulty mounting of the platen.	Check mounting condition of the platen.	Mount the platen properly.

4) Paper feed failure

Phenomenon	Cause	Check Method	Remedy
Paper is not fed or fed irregularly	The paper cover is not closed properly.		Close the paper cover properly.
	Faulty connection of the motor connector.	Check connection of the motor connector.	Connect the correct or correctly.
	Defective motor.		Replace the mechanism ass'y.
	Battery voltage drop.	Check the battery display of the OLED.	Charge the battery.
	Faulty main PCB ass'y		Replace the main PCB ass'y
	Faulty mounting of the platen.	Check mounting condition of the platen.	Mount the platen properly.
	Paper feed failure	Check whether or not the paper is jamming or torn and caught in the paper path.	Eliminate unnecessary paper in the paper path and set paper properly.
	Foreign substance in the gear.		Eliminate the foreign substance.
	Broken gear		If the gear is broken,replace the mechanism ass'y.

Annex1

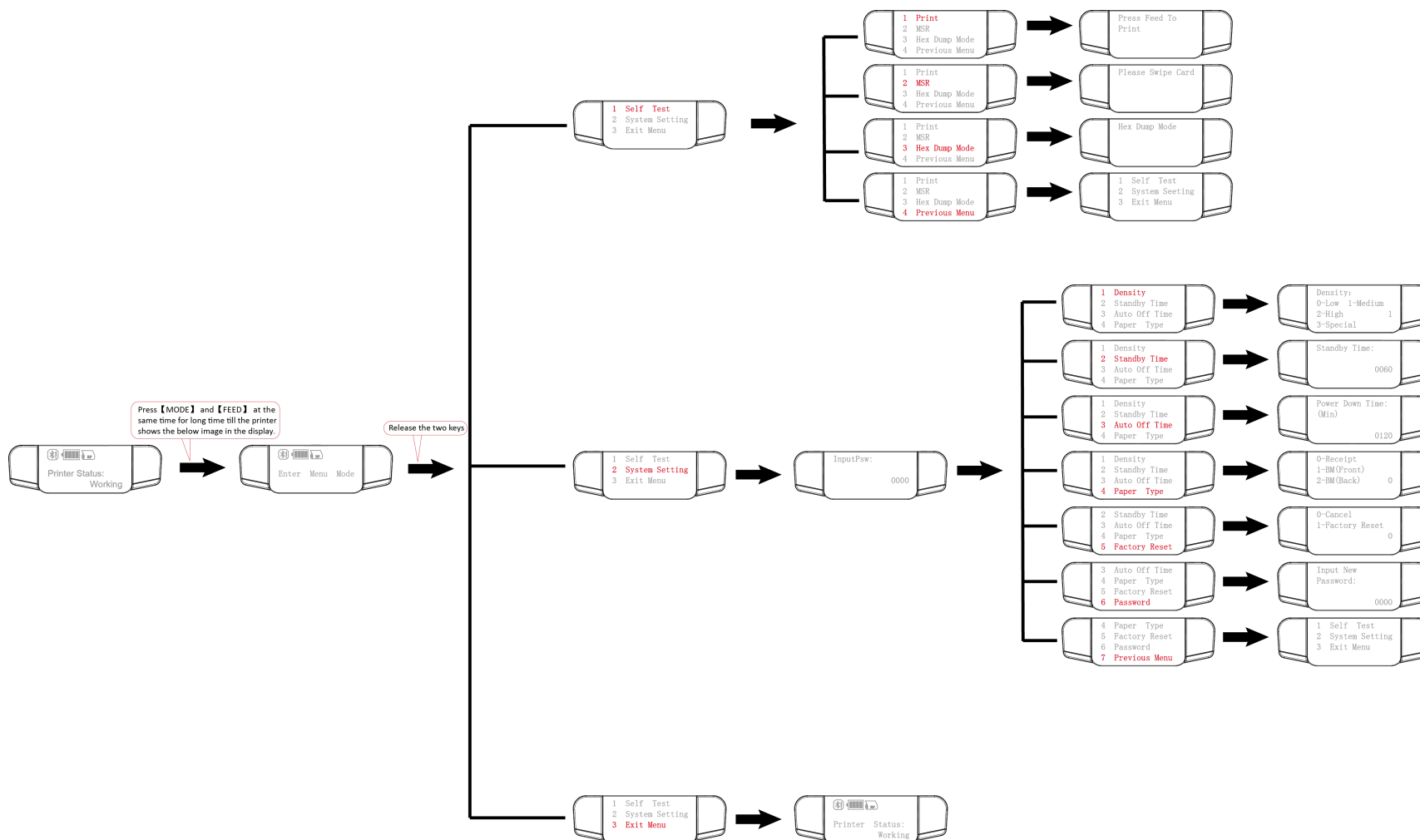

CE2200

FCC Caution.

§ 15.19 Labelling requirements.

This device complies with part 15 of the FCC Rules. Operation is subject to the following two conditions: (1) This device may not cause harmful interference, and (2) this device must accept any interference received, including interference that may cause undesired operation.

§ 15.21 Information to user.

Any Changes or modifications not expressly approved by the party responsible for compliance could void the user's authority to operate the equipment.

§ 15.105 Information to the user.

Note: This equipment has been tested and found to comply with the limits for a Class B digital device, pursuant to part 15 of the FCC Rules. These limits are designed to provide reasonable protection against harmful interference in a residential installation. This equipment generates uses and can radiate radio frequency energy and, if not installed and used in accordance with the instructions, may cause harmful interference to radio communications. However, there is no guarantee that interference will not occur in a particular installation. If this equipment does cause harmful interference to radio or television reception, which can be determined by turning the equipment off and on, the user is encouraged to try to correct the interference by one or more of the following measures:

- Reorient or relocate the receiving antenna.
- Increase the separation between the equipment and receiver.
- Connect the equipment into an outlet on a circuit different from that to which the receiver is connected.
- Consult the dealer or an experienced radio/TV technician for help.

*RF warning for Mobile device:

This equipment complies with FCC radiation exposure limits set forth for an uncontrolled environment.

This equipment should be installed and operated with minimum distance 20cm between the radiator & your body.