Evaluation board for ST95HF NFC transceiver

Introduction

The EVAL-ST95HF is a ready-to-use development kit used to evaluate functions and performances of the RF transceiver ST95HF in Reader mode, Card emulation mode or Peer to Peer Mode for standard contactless applications.

The EVAL-ST95HF kit supports:

- ISO/IEC 14443 Type A and B communication in Reader;
- ISO/IEC 15693 in Reader mode only;
- ISO/IEC 14443 Type A communication in Card emulations mode;
- ISO/IEC 18092 protocols in Reader modes.

The ST95HF also supports the detection, reading and writing of NFC Forum Type 1, 2, 3 and 4 tags.

The EVAL-ST95HF kit includes a ST95HF transceiver, a 4 turns 47 x 34 mm 13.56 MHz inductive etched antenna and its associated tuning components, a STM32F103 32-bits microcontroller with 1 Mbyte of Flash memory and a TFT LCD 2.4 inch and 240*230 resolution.

Table 1. Ordering information

Reference	Order code
EVAL-ST95HF	EVAL-ST95HF

Contents

- 1 Description 5**
- 2 Features 6**
- 3 Hardware and layout description 7**
 - 3.1 Eval-ST95HF assembly drawing 7
 - 3.2 Eval-ST95HF board powering and Startup 8
 - 3.3 Program/debug the RF transceiver demo board. 9
 - 3.4 Electrical schematics 9
- 4 Bill of material 11**
- 5 Federal Communications Commission (FCC) and Industry Canada (IC) compliance statements 17**
 - 5.1 FCC Compliance Statement 17
 - 5.1.1 Part 15.19 17
 - 5.1.2 Part 15.21 17
 - 5.1.3 FCC ID 17
 - 5.2 IC Compliance Statement 17
 - 5.2.1 Compliance Statement 17
 - 5.2.2 Déclaration de conformité 17
 - 5.2.3 IC ID 17
- 6 Revision history 18**

List of tables

Table 1.	Ordering information	1
Table 2.	Bill of materials	11
Table 3.	Document revision history	18

DRAFT

List of figures

Figure 1.	Functional block diagram	5
Figure 2.	Top assembly view	7
Figure 3.	Bottom assembly view	7
Figure 4.	EVAL-ST95HF RF transceiver board top picture	8
Figure 5.	EVAL-ST95HF RF transceiver board back picture	8
Figure 6.	Electric schematics diagram	10

DRAFT

1 Description

The EVAL-ST95HF board includes a ST95HF transceiver, a 4 turns 47 X 34 mm, 13.56 MHz inductive etched antenna and its associated tunings components, a STM32F103 32-bits microcontroller with 1Mbytes of Flash memory and a TFT LCD 2.4 inch and 240*230 resolutions. The functional scheme is shown in [Figure 1](#).

It is powered by USB cable. A SPI bus allows the microcontroller to communicate with the ST95HF and LCD screen.

A 4 positions joystick is used to move in the menu.

Two other pushbuttons are placed on the board, one for the reset, the second to rotate the LCD picture.

The download is possible through the JTAG connector.

The ST android application "ST95HF demo App" shows a proprietary IAP application. The user can upload from the NFC reader (NFC Phone or RFID reader) the firmware of the STM32F103 of the EVAL-ST95HF board and boot on it.

More information on the ST95HF evaluation kit and associated demonstration software can be found at www.st.com.

Figure 1. Functional block diagram

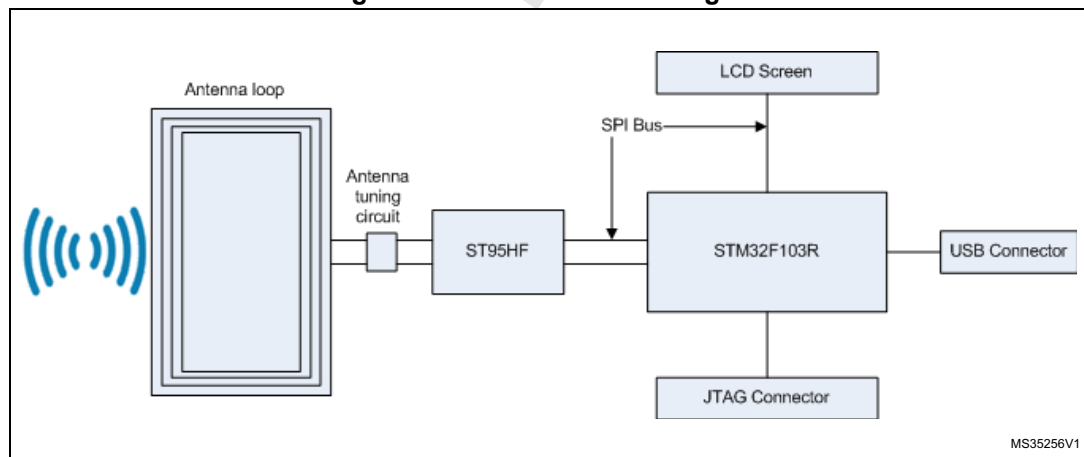

2 Features

- ST95HF, a 13.56-MHz multi-protocol contactless transceiver IC with SPI serial access communication:
- Reader mode
 - ISO/IEC 14443 Type A
 - ISO/IEC 15693
 - ISO/IEC 18092
- Card Emulation mode:
 - ISO/IEC 14443 Type A
- ISO/IEC 14443 Type A in Peer To Peer mode.
- 47 x 34 mm with 4 turn. 13.56 MHz inductive antenna etched on PCB and associated tuning circuit.
- STM32F103RGT6 64LQFP 32-bits microcontroller, with 1Mbytes of Flash memory and USB interface in a 64-pin LQFP package.
- KF33BDT, a 3.3V low dropout (LDO) voltage regulator
- USB mini B connector
- NX2016SA, a 27.12-MHz EXS00A-CS01188 crystal oscillator for ST95HF transceiver
- HC-49SD 8.000MHz 20pF/80ppm for STM32
- 20-pin JTAG connector for STM32 programming and debugging
- 2 push button (Reset & 180 degree rotation of the LCD screen)
- 1 joystick 4 directions + select
- 5 different color LEDs indicating the presence of RF field and protocol used for communicating.
- JTAG connector for microcontroller firmware upgrade and debug.
- LCD color screen (320*200pixels).
- USB cable: Type A / mini B

3 Hardware and layout description

3.1 Eval-ST95HF assembly drawing

The top and bottom assembly views are shown in [Figure 2](#) and [Figure 3](#), respectively.

Figure 2. Top assembly view

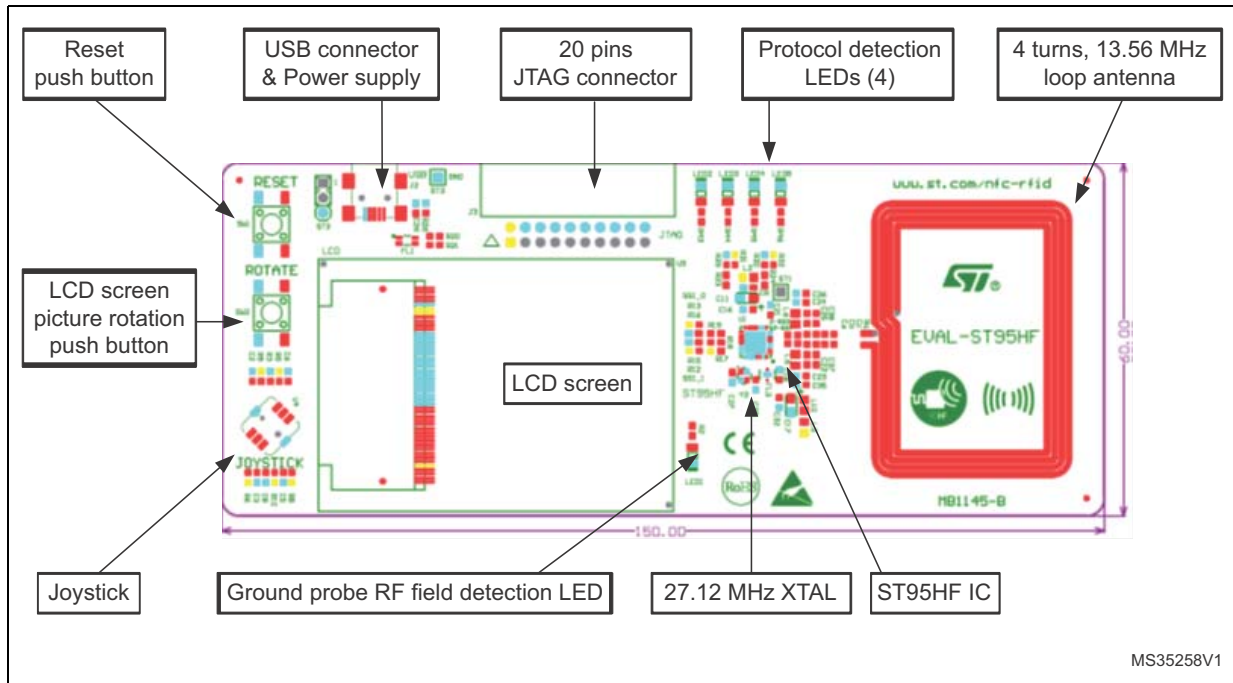
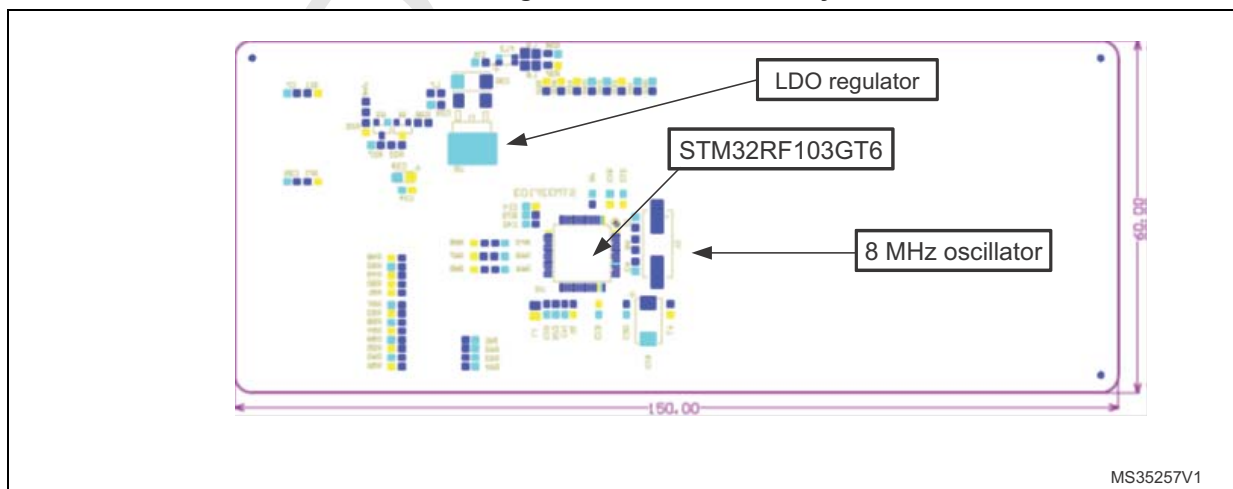

Figure 3. Bottom assembly view



The corresponding pictures of the final board are shown in [Figure 4](#) and [Figure 5](#).

Figure 4. EVAL-ST95HF RF transceiver board top picture

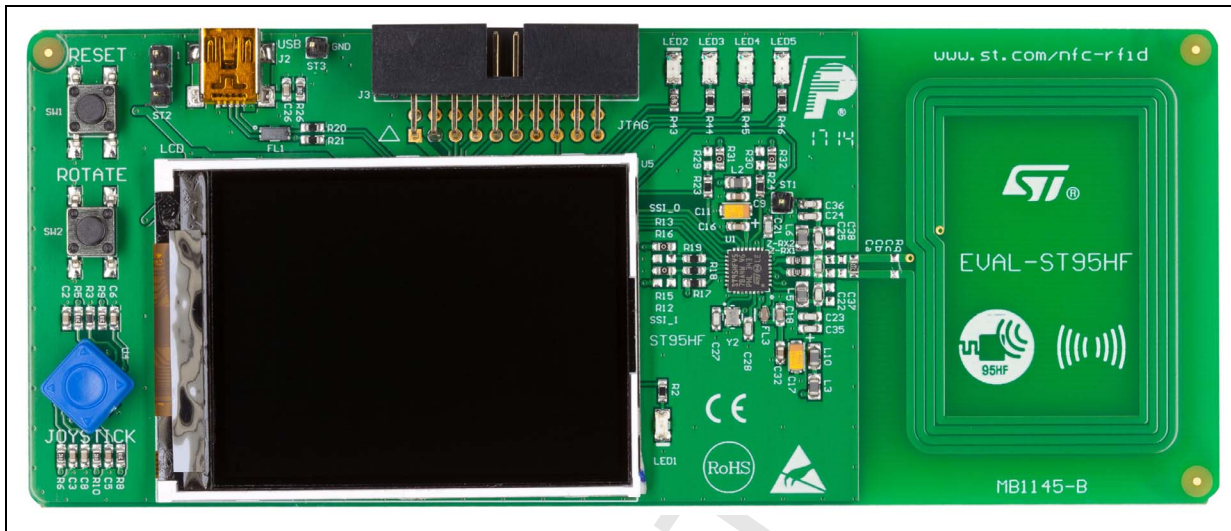
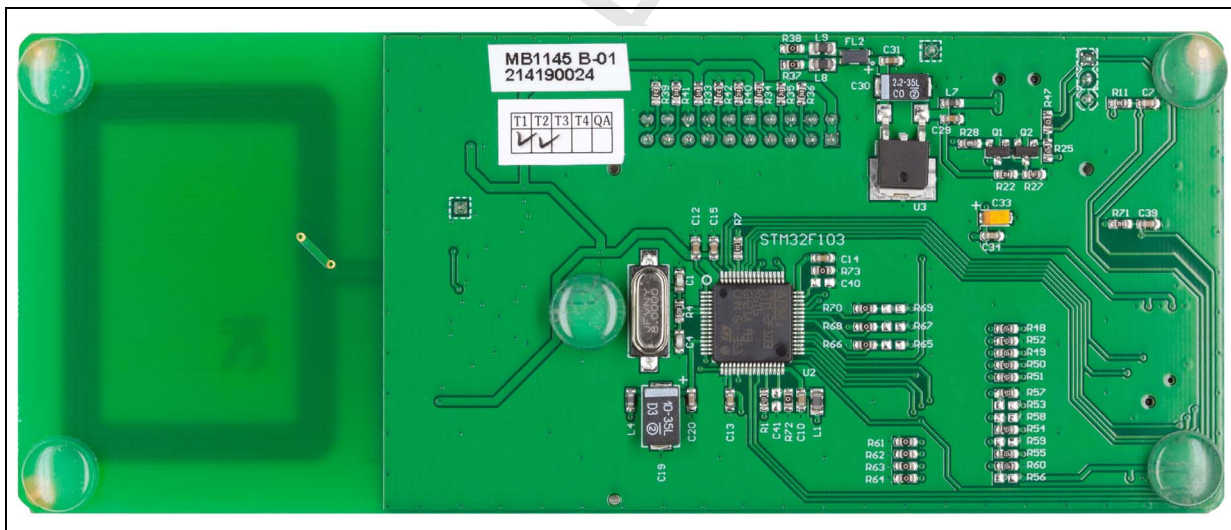

Figure 5. EVAL-ST95HF RF transceiver board back picture



3.2 Eval-ST95HF board powering and Startup

The EVAL-ST95HF board is powered by the USB bus via a Type A / mini B USB cable connected to a PC.

When powered up, the ST95HF starts the firmware already downloaded in STM32 flash memory. A general menu appears in which you can reach in various function of the ST95HF: user can choose mainly between two modes, namely Card emulation mode or NFC reader mode.

A push button is placed in order to choose the ST95HF LCD screen picture orientation according to the board direction or in case of two ST95HF used “face to face”.

Please refer to the firmware user manual available on ST web site www.st.com to get more detail.

3.3 Program/debug the RF transceiver demo board.

In order to flash or debug an STM32 microcontroller application on the EVAL-ST95HF board, simply connect the 20-pin JTAG/SWD flat ribbon of the STLINK/V2 in-circuit debugger and programmer to the RF transceiver demonstration board JTAG connector (J3), then launch STLink.

For more information, documentation about the STLINK/V2 in-circuit debugger and programmer, please visit www.st.com.

3.4 Electrical schematics

A detailed view of the electrical schemes for the EVAL-ST95HF board can be found in [Figure 6](#).



Figure 6. Electric schematics diagram

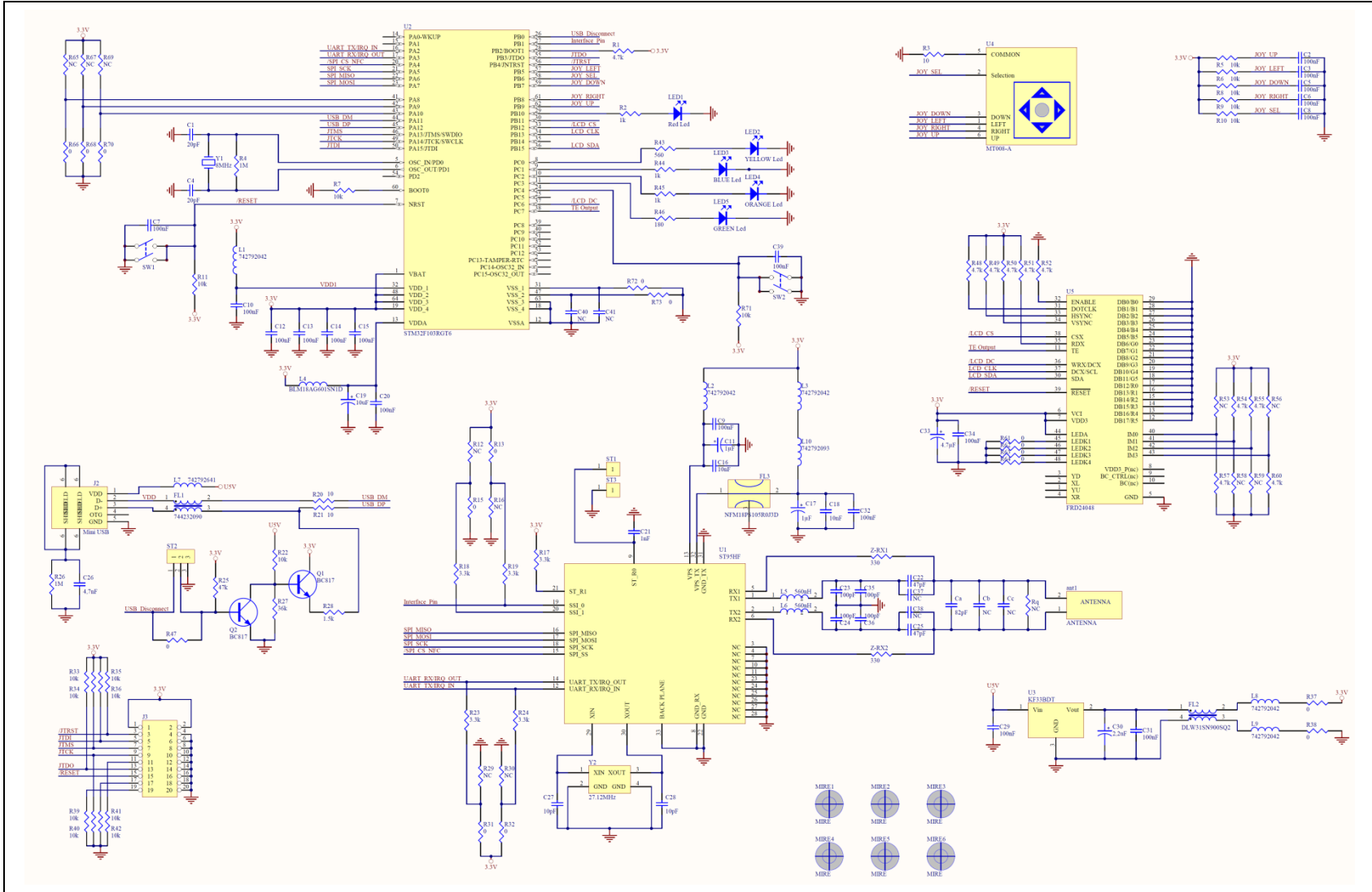



4 Bill of material

The parts needed for the EVAL-ST95HF development kit are listed in [Table 2](#).

Table 2. Bill of materials

Quantity	Description	Reference	Package	Manufacturer	Part number	Distributor	Order code
1	ST95HFVMD5 ST95HF	U1	VFQFPN32_5x5	STMicroelectronics	ST95HF VMD5T	-	-
1	MCU 32 BITS 1MB Flash 64LQFP STM32F103RGT6	U2	LQFP64_10x10	STMicroelectronics	STM32F103RGT6	-	-
1	3.3V Voltage regulator KF33BDT	U3	DPAK	STMicroelectronics	KF33BDT	-	-
1	Joystick 4 directions1 select Wealth Metal Factory MT008-A	U4	JOYSTICK_MT-008A	Wealth Metal Factory	MT008-A	-	-
1	LCD Screen FRD24048	U5	SF-TC240T-48P-07	FRDA LCD	FRD24048	-	-
2	293D TANTAL SMD POL CAP 1uF 16V 10% Boitier A 1µF	C11, C17	293D-A	-	-	Farnell	1754174
1	293D TANTAL SMD POL CAP 2,2uF 35V 10% Boitier C 2,2uF	C30	293D-C	-	-	Farnell	1754228
1	293D TANTAL SMD POL CAP 4,7uF 16V 10% Boitier A 4.7µF	C33	293D-A	-	-	Farnell	1754174
1	293D TANTAL SMD POL CAP 10uF 35V 10% boitier D 10uF	C19	293D-D	-	-	Farnell	2112949
6	CONDENSATEUR MLCC 0603 NP0 50V 2% NC ⁽¹⁾	C37, C38, C40, C41, Cb, Cc	0603	-	-	-	-



Table 2. Bill of materials (continued)

Quantity	Description	Reference	Package	Manufacturer	Part number	Distributor	Order code
2	CONDENSATEUR MLCC 0603 NP0 50V 2% 47pF	C22, C25	0603	Murata ⁽²⁾	GRM1885C1H470GA01	-	-
4	CONDENSATEUR MLCC 0603 NP0 50V 2% 100pF	C23, C24, C35, C36	0603	Murata ⁽²⁾	GRM1885C1H101GA01	-	-
1	CONDENSATEUR MLCC 0603 NP0 50V 2% 82pF	Ca	0603	Murata ⁽²⁾	GRM1885C1H820GA01	-	-
2	CONDENSATEUR MLCC 0603 NP0 50V 5% 10pF	C27, C28	0603	-	-	Farnell	1759053
2	CONDENSATEUR MLCC 0603 NP0 50V 5% 20pF	C1, C4	0603	-	-	Farnell	1844172
1	CONDENSATEUR MLCC 0603 NP0 50V 5% 1nF	C21	0603	-	-	Farnell	1759089
1	CONDENSATEUR MLCC 0603 NP0 50V 5% 4,7nF	C26	0603	-	-	Farnell	1833869
2	CONDENSATEUR MLCC 0603 NP0 50V 5% 10nF	C16, C18	0603	-	-	Farnell	1833871
18	CONDENSATEUR MLCC 0603 NP0 50V 5% 100nF	C2, C3, C5, C6, C7, C8, C9, C10, C12, C13, C14, C15, C20, C29, C31, C32, C34, C39	0603	-	-	Farnell	1740621
1	NOISE SUPPRESSOR CMS 90OHM. 370MA 744232090	FL1	744232xxx	WURTH ELEKTRONIK ⁽²⁾	744232090	Farnell	1636474
1	NOISE SUPPRESSOR CMS 90OHM. 0.37A DLW31SN900SQ2	FL2	744232xxx	Murata ⁽²⁾	DLW31SN900SQ2	Radiospares	724-1687

Table 2. Bill of materials (continued)

Quantity	Description	Reference	Package	Manufacturer	Part number	Distributor	Order code
1	FILTER SUPPRESSION, 0603, 1UF, 6.3VDC NFM18PS105R0J3D	FL3	NFM18PS	Murata ⁽²⁾	NFM18PS105R0J3D	Farnell	1686506
5	FERRITE CMS 600OHM. 0805 742792042	L1, L2, L3, L8, L9	0805	WURTH ELEKTRONIK ⁽²⁾	742792042	Farnell	1635716
1	FERRITE CMS 2200OHM. 0805 742792093	L10	0805	WURTH ELEKTRONIK ⁽²⁾	742792093	Farnell	1635726
1	FERRITE BEAD, 0.38OHM, 500MA, 0603 BLM18AG601SN1D	L4	0603	Murata ⁽²⁾	BLM18AG601SN1D	Farnell	1515679
1	FERRITE CMS 300OHM. 0603 742792641	L7	0603	WURTH ELEKTRONIK ⁽²⁾	742792641	Farnell	1635705
2	Inductor SMD 0805, LQM21NNR56K10D 560nH	L5, L6	0805	Murata ⁽²⁾	LQM21NNR56K10D	Radiospares	786-7087
12	Resistance CMS 0603 0,1W 5% NC ⁽¹⁾	R12, R16, R29, R30, R53, R56, R58, R59, R65, R67, R69, Rq	0603	-	-	-	-
16	Resistance CMS 0603 0,1W 5% 0	R13, R15, R31, R32, R37, R38, R47, R61, R62, R63, R64, R66, R68, R70, R72, R73	0603	-	-	-	-
3	Resistance CMS 0603 0,1W 5% 10	R3, R20, R21	0603	-	-	-	-
1	Resistance CMS 0603 0,1W 5% 180	R46	0603	-	-	-	-



Table 2. Bill of materials (continued)

Quantity	Description	Reference	Package	Manufacturer	Part number	Distributor	Order code
2	Resistance CMS 0603 0,1W 5% 330	Z-RX1, Z-RX2	0603	-	-	-	-
1	Resistance CMS 0603 0,1W 5% 560	R43	0603	-	-	-	-
3	Resistance CMS 0603 0,1W 5% 1k	R2, R44, R45	0603	-	-	-	-
1	Resistance CMS 0603 0,1W 5% 1.5k	R28	0603	-	-	-	-
5	Resistance CMS 0603 0,1W 5% 3.3k	R17, R18, R19, R23, R24	0603	-	-	-	-
10	Resistance CMS 0603 0,1W 5% 4.7k	R1, R48, R49, R50, R51, R52, R54, R55, R57, R60	0603	-	-	-	-
17	Resistance CMS 0603 0,1W 5% 10k	R5, R6, R7, R8, R9, R10, R11, R22, R33, R34, R35, R36, R39, R40, R41, R42, R71	0603	-	-	-	-
1	Resistance CMS 0603 0,1W 5% 36k	R27	0603	-	-	-	-
1	Resistance CMS 0603 0,1W 5% 47k	R25	0603	-	-	-	-
2	Resistance CMS 0603 0,1W 5% 1M	R4, R26	0603	-	-	-	-
1	Mini USB 5075BMR-05-SM	J2	5075BMR-05-SM	Neltron Industrial	5075BMR-05-SM	-	-
1	HEADER, RIGHT ANGLE, 20WAY	J3	HE10_20PTS_M_COUDE	MULTICOMP	MC9A22-2034	Farnell	1099248

Table 2. Bill of materials (continued)

Quantity	Description	Reference	Package	Manufacturer	Part number	Distributor	Order code
2	Connector 1PT, NC	ST1, ST3	CON_1PTS	FCI	77311-401-36LF	Farnell	1097954
1	Connector 3PTS 2,54, NC ⁽¹⁾	ST2	CON_3PTS_P2.54	FCI	77311-401-36LF	Farnell	1097954
2	Push Button SW_BP_ST ⁽¹⁾	SW1, SW2	FSM4JSMA	ALCOSWITCH	FSM4JSMA	Farnell	3801305
1	LED, 1206, RED, 80MCD, 635NM RED Led	LED1	LED-1206	DIALIGHT	598-8210107F	Farnell	1850747
1	LED, 1206, YELLOW, 130MCD, 593NM YELLOW Led	LED2	LED-1206	DIALIGHT	5988240107F	Farnell	1465998
1	LED, 1206, BLUE, 140MCD BLUE Led	LED3	LED-1206	DIALIGHT	5988291107F	Farnell	1850752
1	LED, 1206, ORANGE, 110MCD, 610NM ORANGE Led	LED4	LED-1206	DIALIGHT	5988230107F	Farnell	1872396
1	LED, 1206, GREEN, 20MCD, 570NM GREEN Led	LED5	LED-1206	DIALIGHT	5988270107F	Farnell	1466000
2	BC817-16 - TRANSISTOR NPN 0.5A 45V SOT23 BC817	Q1, Q2	SOT23	MULTICOMP	BC817-16	Farnell	1798077
1	SMD CRYSTAL OSCILLATOR,8M,20PF,20p pm 8MHz	Y1	HC49SD	FOX ELECTRONICS ⁽²⁾	FOXSDLF/080-20	Farnell	2063972
1	NX2016SA 27.12MHz EXS00A-CS01188 27.12MHz	Y2	NX2016	NDK ⁽²⁾	NX2016SA 27.12MHz EXS00A-CS01188	-	-
1	NFC Antenna ⁽¹⁾	ant1	ANT_90DEG	-	-	-	-



Table 2. Bill of materials (continued)

Quantity	Description	Reference	Package	Manufacturer	Part number	Distributor	Order code
6	PCB MIRE ⁽¹⁾	MIRE1, MIRE2, MIRE3, MIRE4, MIRE5, MIRE6	MIRE	-	-	-	-
1	PCB ⁽³⁾ 150mmx60mmx1.6mm (FR4, dual side, components on both sides, green color)	-	-	-	-	-	-
5	Bumpon protective product	-	3M	SJ5306	-	-	-
1	Five_way switch button hat, PB-504/PB-MT008A (Cyan), along, AKG004, for U4	-	-	-	-	-	-
1	Carton box ⁽¹⁾	-	-	-	-	-	-

1. Not fitted
2. No double source allowed
3. Version B

5 Federal Communications Commission (FCC) and Industry Canada (IC) compliance statements

5.1 FCC Compliance Statement

5.1.1 Part 15.19

This device complies with Part 15 of the FCC Rules. Operation is subject to the following two conditions: (1) this device may not cause harmful interference, and (2) this device must accept any interference received, including interference that may cause undesired operation.

5.1.2 Part 15.21

Any changes or modifications to this equipment not expressly approved by STMicroelectronics may cause harmful interference and void the user's authority to operate this equipment.

5.1.3 FCC ID

FCC ID: YCPEVALST95HF

5.2 IC Compliance Statement

5.2.1 Compliance Statement

This device complies with Industry Canada licence-exempt RSS standard(s). Operation is subject to the following two conditions: (1) this device may not cause interference, and (2) this device must accept any interference, including interference that may cause undesired operation.

5.2.2 Déclaration de conformité

Le présent appareil est conforme aux CNR d'Industrie Canada applicables aux appareils radio exempts de licence. L'exploitation est autorisée aux deux conditions suivantes: (1) l'appareil ne doit pas produire de brouillage, et (2) l'utilisateur de l'appareil doit accepter tout brouillage radioélectrique subi, même si le brouillage est susceptible d'en compromettre le fonctionnement.

5.2.3 IC ID

IC ID: 8976A-EVALST95HF

6 Revision history

Table 3. Document revision history

Date	Revision	Changes
20-Jun-2014	1	Initial release.
dd-Mar-2015	2	Added <i>Section 5: Federal Communications Commission (FCC) and Industry Canada (IC) compliance statements.</i>

DRAFT

IMPORTANT NOTICE – PLEASE READ CAREFULLY

STMicroelectronics NV and its subsidiaries ("ST") reserve the right to make changes, corrections, enhancements, modifications, and improvements to ST products and/or to this document at any time without notice. Purchasers should obtain the latest relevant information on ST products before placing orders. ST products are sold pursuant to ST's terms and conditions of sale in place at the time of order acknowledgement.

Purchasers are solely responsible for the choice, selection, and use of ST products and ST assumes no liability for application assistance or the design of Purchasers' products.

No license, express or implied, to any intellectual property right is granted by ST herein.

Resale of ST products with provisions different from the information set forth herein shall void any warranty granted by ST for such product.

ST and the ST logo are trademarks of ST. All other product or service names are the property of their respective owners.

Information in this document supersedes and replaces information previously supplied in any prior versions of this document.

© 2015 STMicroelectronics – All rights reserved