



## Before You Begin...

- **Consult your local authorities for any permits required to construct shed.**

Prior to the construction of your shed, check with the local building code official to review any required permits or building limitations.

- **A level and sturdy foundation is required before shed construction can begin.**

Foundation recommendations and options are available in this manual.

- **Read instructions thoroughly prior to assembly.**

This kit contains parts that can be damaged if assembled incorrectly or in the wrong sequence.

- **Please follow instructions.**

Suncast is not responsible for replacing parts lost or damaged due to incorrect assembly.

- **Check for all parts before you begin.**

Using the provided parts check list on page 3, verify that you have all the parts required to construct your shed model. **COMPLETE SITE PREPARATION AND FOUNDATION CONSTRUCTION BEFORE UNPACKING ALL PARTS.**

- **Assistance is required.**

Due to the size of the parts, at least two people are required to handle, fit and secure shed components.



## CAUTION

- Shed not intended for use in extreme weather conditions.
- Shed not intended for storage of flammable or caustic chemicals.
- Store heavy items near the bottom of shed.
- Shed not intended for use by children.
- Do not stand, sit, or store items on storage shed roof.
- Treat carefully in extreme temperatures.
- Repair or replace broken parts immediately.
- Suncast is not responsible for damage caused by weather or misuse.
- At regular intervals inspect your shed to make sure that assembly integrity has been maintained.
- Periodically check that the location you have chosen to set your shed is still level.
- This kit contains parts with metal edges. Please be careful when handling.

## Shed Safety and Care

- Wash shed with garden hose or mild detergent solution and soft cloth. Do not use a stiff brush or abrasive cleaner as that could damage shed.
- Hot items, such as recently used grills, blowtorches, etc., must not be stored in the shed.
- Heavy articles should not be leaned against the walls, as this may cause panel distortion and permanent damage.
- Keep roof clean of snow and leaves.

## Tools Required:

- |                             |                     |                          |
|-----------------------------|---------------------|--------------------------|
| • Flat blade screwdriver    | • Adjustable wrench | • Level                  |
| • Phillips head screwdriver | • Ladder            | • Light duty work gloves |
| • Small rubber mallet       | • Eye protection    |                          |

## Assembly Day Tips:

- **Complete site preparation and foundation construction before unpacking parts and beginning assembly.**
- **Do not attempt to assemble on a day with strong winds.**
- **Do not attempt to assemble on days when temperature is below 32 degrees.**
- **Set aside appropriate amount of time to completely assemble shed.**
- **Make sure you have assistance nearby to lift and secure parts in place.**
- **Wear light duty work gloves while assembling shed.**
- **If you have questions on assembly, please call 800-846-2345.**

**NOTE:** This product contains parts that are used in different orientations to construct the shed. Please take note of the orientation of the parts shown throughout this instruction manual. Failure to follow instructions could result in damage to parts. Suncoast is not responsible for replacing parts lost or damaged due to incorrect assembly.

**STRONGLY RECOMMENDED:** Before beginning assembly, familiarize yourself with the parts by comparing the parts you have with the part names and quantities listed below. Use the Part Recognition illustrations on pages 4 and 5 to help identify parts. **If a part is missing or damaged, please make note of which part it is and call 800-846-2345 for assistance.**

<b>Parts List</b>		
<b>Part Name</b>	<b>Part Letter</b>	<b>7 1/2' W x 3' D Qty</b>
Front Panel	A-A	2
Floor Post Connector	B	6
Male Ridge End	C	1
Left Door	DL	1
Left Header Panel	EL	2
Right Header Panel	ER	2
Right Door	DR	1
Floor	F-A	2
Female Corner Post	G	4
Male Corner Post	H	4
Female Ridge End	K	1
Right Hinge Post	L	1
Door Latch Housing	M	2
Door Latch Pin	N	2
Left Hinge Post	P	1
Back To Header Connector	R	4
Side Panel	S	5
Right Door Handle	T	1
Roof to Side Connector	U	2
Left Door Handle	W	1
Right Roof Corner	X-A	2
Header to Header Snap	Y	2
Roof to Beam Connector	Z	2
Hinge Pin	DD	2
Left Roof Corner	CC-A	2
Right Floor to Back Connector	NN-A	1
Left Floor to Back Connector	MM-A	1
Left Floor to Front Connector	JJ-A	1
Right Floor to Front Connector	KK-A	1
#8-10 x 3/4" Pan Head Screw		26
Steel Side Panel Support		2
Header Support Tube		2
Header Support Tube Bracket		2
Steel Ridge Beam		1

## Small Part Recognition

Using the illustrations, familiarize yourself with the parts required to construct your shed. Parts shown are not to scale.

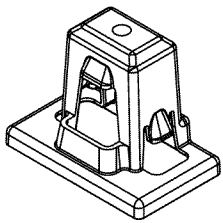

010160918  
B  
Floor Post Connector

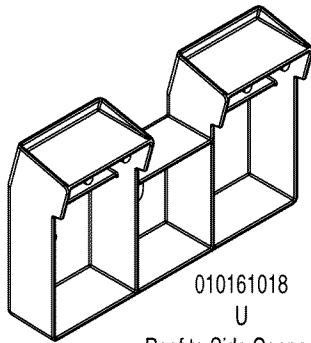

010161018  
U  
Roof to Side Connector

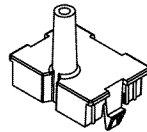

010161192  
DD  
Hinge Pin

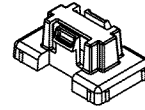

010157792  
Y  
Header to Header Snap

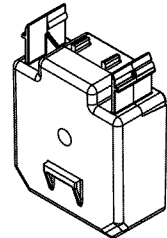

010161318  
R  
Back to Header Connector

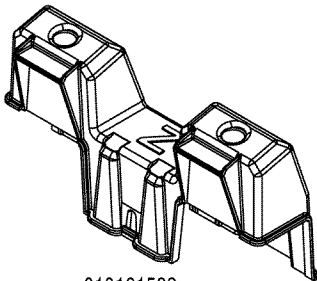

010161592  
Z  
Roof to Roof Connector

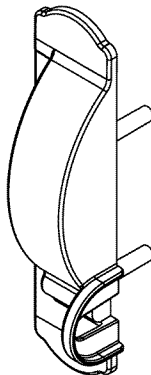

010161292  
W  
Left Door Handle



010162192  
T  
Right Door Handle

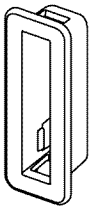

010122292  
M  
Door Latch Housing

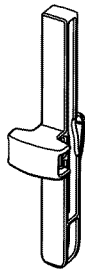

010122192  
N  
Door Latch Pin

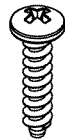

0210081  
#8 - 10 x 3/4"  
Pan Head Screw

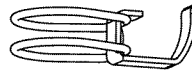

0280262  
Header Support Tube Bracket



0280261  
Header Support Tube



0280274  
Steel Side Panel Support

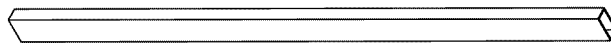

0280277 - 7 1/2 x 3 ft Beam

# Large Part Recognition

Using the illustrations, familiarize yourself with the parts required to construct your shed. Parts shown are not to scale.

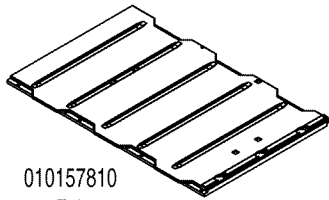

010157810  
F-A  
Floor Panel



010159518  
JJ-A  
Left Floor to Front Connector

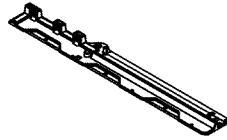

010159718  
KK-A  
Right Floor to Front Connector

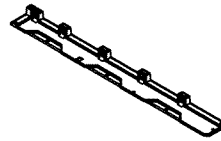

010159918  
MM-A  
Left Floor to Back Connector

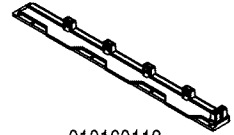

010160118  
NN-A  
Right Floor to Back Connector



010158518  
H  
Male  
Corner  
Post

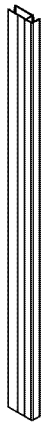

010158618  
G  
Female  
Corner  
Post



010158118  
A-A  
Front Panel



010159318  
P  
Left Hinge Post



010159418  
L  
Right Hinge Post

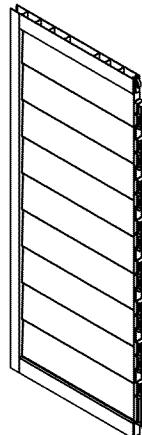

010158018  
S  
Side Panel

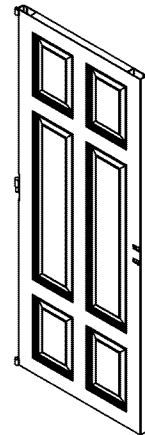

010158392  
DL  
Left Door

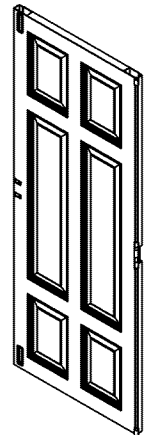

010158492  
DR  
Right Door

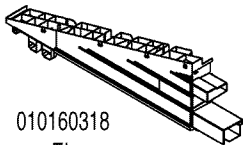

010160318  
EL  
Left Header Panel

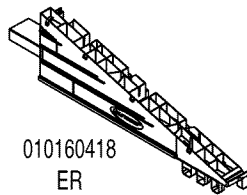

010160418  
ER  
Right Header Panel

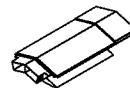

010160792  
C  
Male Ridge End

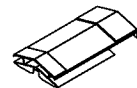

010160892  
K  
Female Ridge End

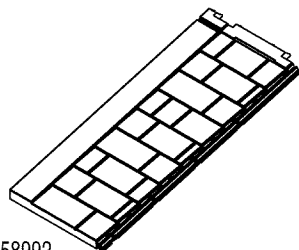

010158992  
CC-A  
Left Roof Corner

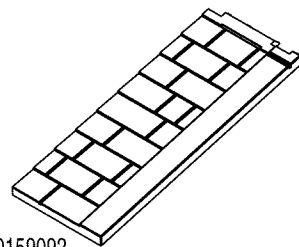

010159092  
X-A  
Right Roof Corner

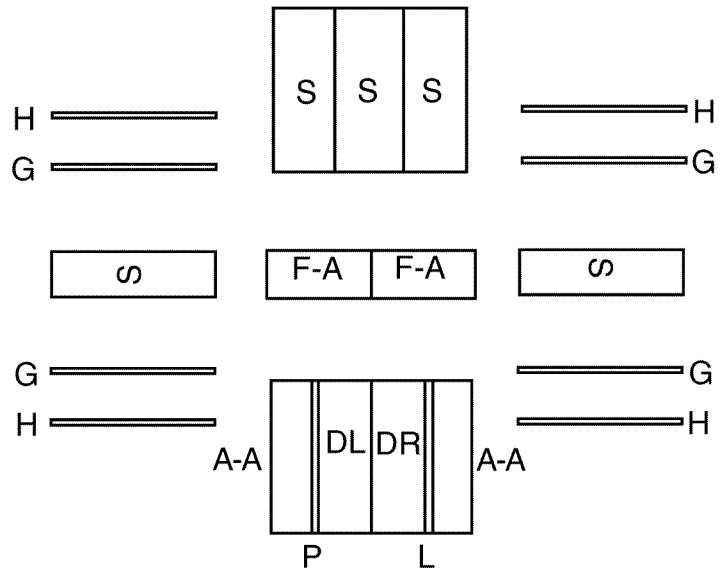

## Floor Panel and Side Panel Layout

Using the illustrations, familiarize yourself with the parts required to construct your shed.

---

## Site Preparation and Foundation Construction (Materials not supplied with Shed Kit)

**NOTE: Site preparation is required for this shed.** Placing the shed on a constructed foundation is highly recommended. Without a constructed foundation, settling will probably occur, causing distortion and damage to the shed. Suncoast is not responsible for replacing parts damaged or property lost due to incorrect assembly.

**NOTE: Complete the site preparation and foundation construction before unpacking parts and beginning assembly.**

### To prepare your Shed site, follow the below steps:

1. Consult your local authorities for building codes and covenants before beginning foundation or erecting shed.
2. Before any digging, check with local utilities to determine location of buried cables, pipes, etc.
3. Decide which type of foundation you want:
  - Concrete slab, 4" thick (**Recommended**)
  - or
  - Wood platform (**Recommended**)  
Use exterior grade wood. The wood platform should be set on pier blocks or footing. Consult your local retailer for help to determine the best anchoring method for your particular installation. The provided plans are sized for the minimum number of cuts to lumber and plywood.
  - Without Constructed Foundation  
See how to anchor assembled base to ground on page 7.
4. Prepare the building site:
  - The ground should slope away from the foundation area to provide drainage.
  - The foundation surface must be flat and level.
  - A vapor barrier should be provided to prevent excessive condensation in the shed.
  - Follow local building codes for a proper vapor barrier.
5. Anchoring the shed to the foundation:
  - Consult your local retailer for help to determine the best anchoring method for your particular installation.
  - To secure the shed to a concrete pad, use masonry fasteners available at your local retailer.
  - To secure the shed to a wood platform, use 1/4" X 2" long lag screws with washers. See diagram on Page 10 for anchoring locations.

## Concrete Slab Dimensions

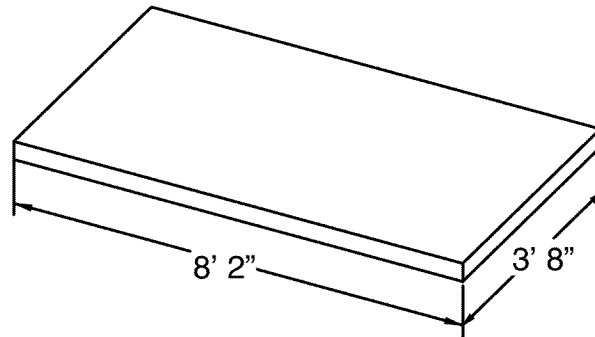

\*Dimensions allow for approx. 3" extra on each side.

## Wood Platform Dimensions

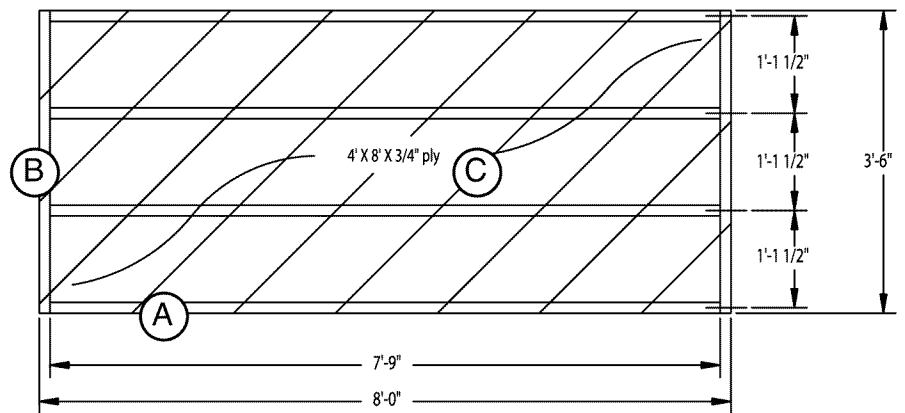
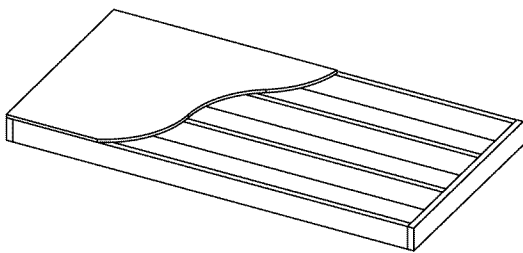

### Materials List

Item	Qty	Size
A	4	2" x 6" x 7' 9"
B	2	2" x 6" x 3' 6"
C	1	3' 6" x 8' x 3/4" plywood

## Anchor Assembled Base To Ground

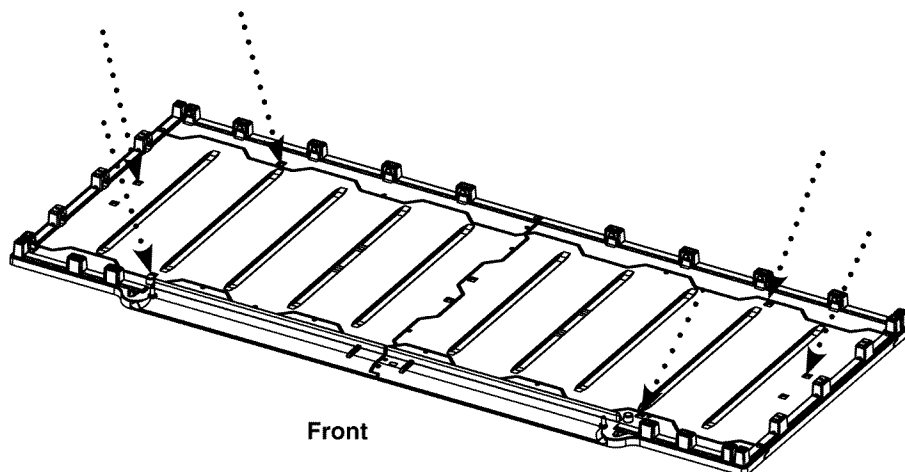

**If you choose not to construct a foundation...** the assembled shed base should be secured to the ground after site preparation is complete. Drill holes through the provided recess areas and insert 12" nails at an angle through the holes in the base and into the ground. 12" nails are available at home centers and hardware stores.

## Shed Assembly

**NOTE: Site preparation is required for this shed.** Placing the shed on a constructed foundation is highly recommended. Without a constructed foundation, settling will probably occur, causing distortion and damage to the shed. Suncoast is not responsible for replacing parts damaged or property lost due to incorrect assembly.

**NOTE: Complete the site preparation and foundation construction before unpacking parts and beginning assembly.**

When assembling shed, light duty work gloves are recommended.

1. With side with opening facing the center of Floor Panels F-A, insert three B Floor Connector Posts into one F-A. Snap into place.

Repeat for second F-A Floor Panel.

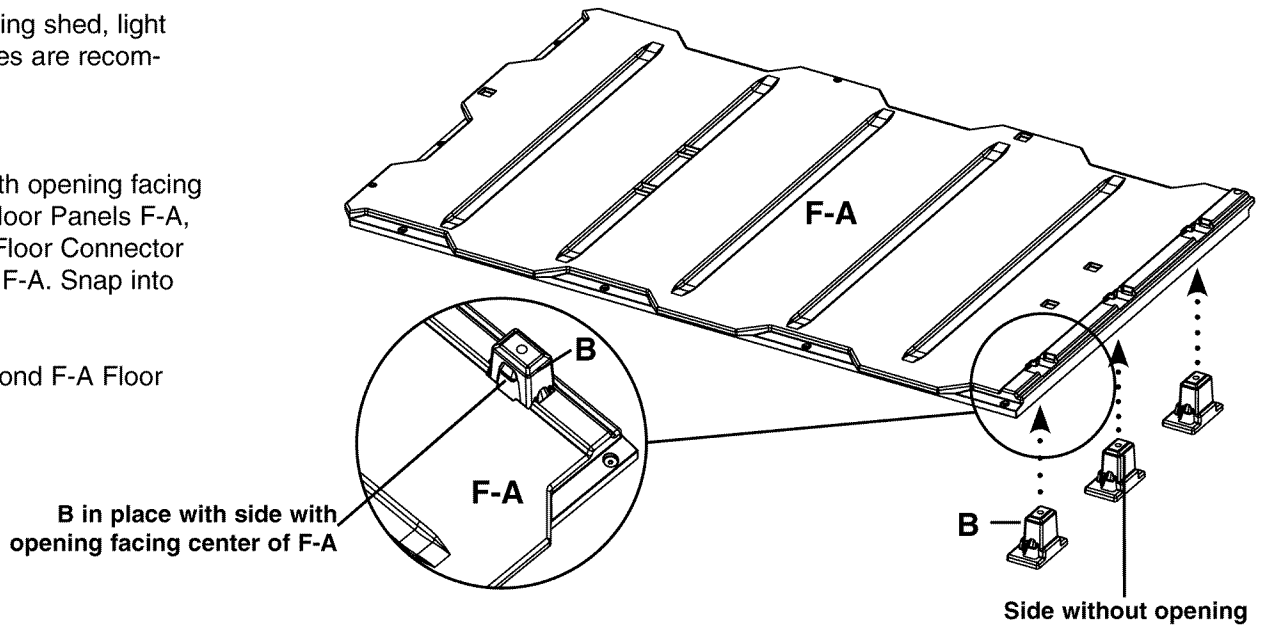

2. Place two F-A Floor Panels next to each other and slide together.

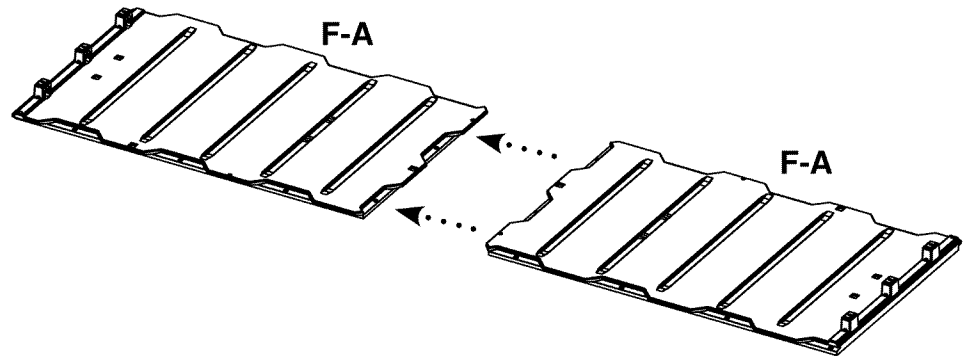

3. Secure F-A Floor Panels with two #8-10 x 3/4" Pan Head Screws.

**DO NOT OVERTIGHTEN SCREWS.**

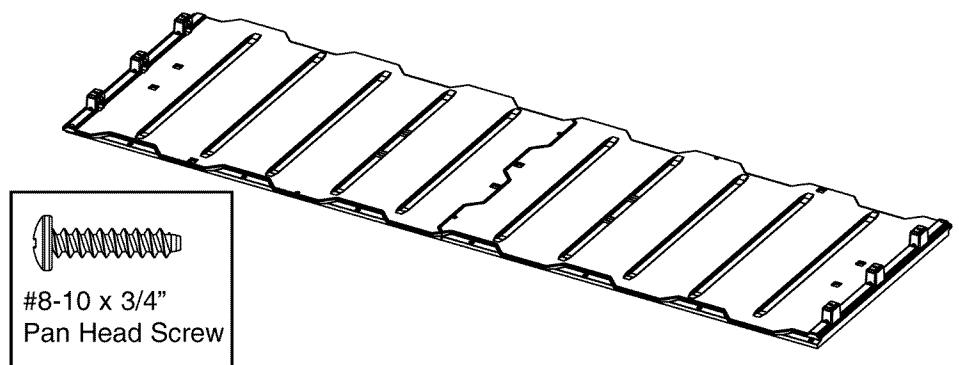



4. Designate one side to be the front of the shed.

Place Floor to Front Connector JJ-A in front of left front Floor Panel and slide together. Secure with #8-10 x 3/4" Pan Head Screws.

**DO NOT OVERTIGHTEN SCREWS.**

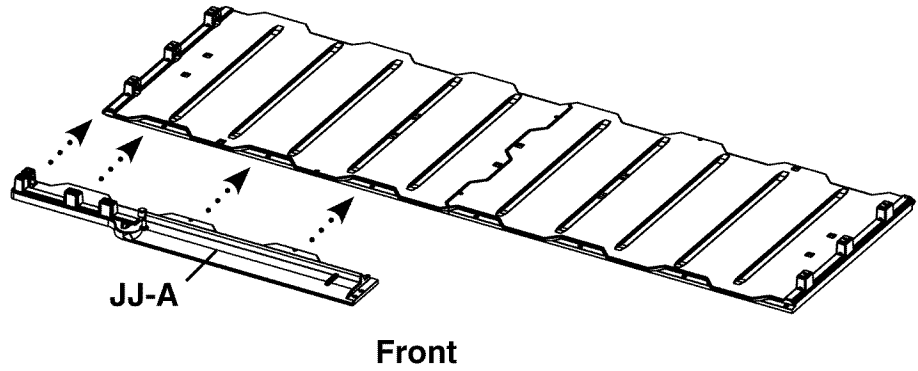

5. Place Floor to Front Connector KK-A in front of right front Floor Panel and slide together. Make sure KK-A overlaps JJ-A where the two meet.

Secure with #8-10 x 3/4" Pan Head Screws.

**DO NOT OVERTIGHTEN SCREWS.**

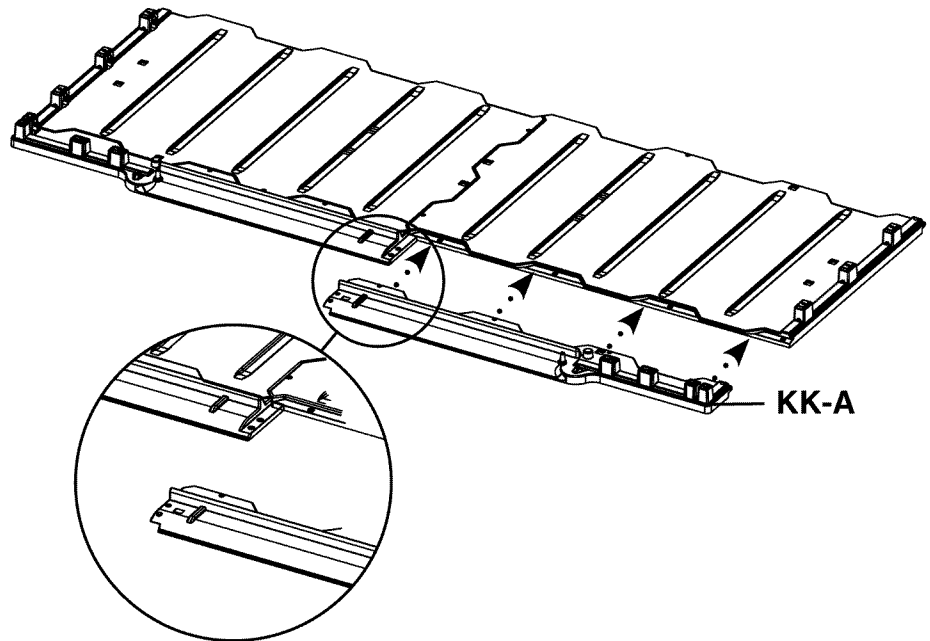

6. Place Floor to Back Connector NN-A in front of right back Floor Panel and slide together. Secure with #8-10 x 3/4" Pan Head Screws.

**DO NOT OVERTIGHTEN SCREWS.**

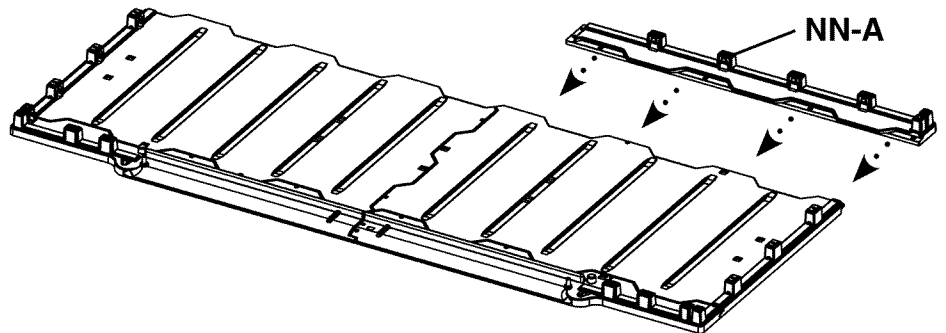

7. Place Floor to Back Connector MM-A in front of left back Floor Panel and slide together. Secure with #8-10 x 3/4" Pan Head Screws.

Make sure MM-A overlaps NN-A where the two meet.

**DO NOT OVERTIGHTEN SCREWS.**

After installing screws check all screw locations to ensure that none were missed.

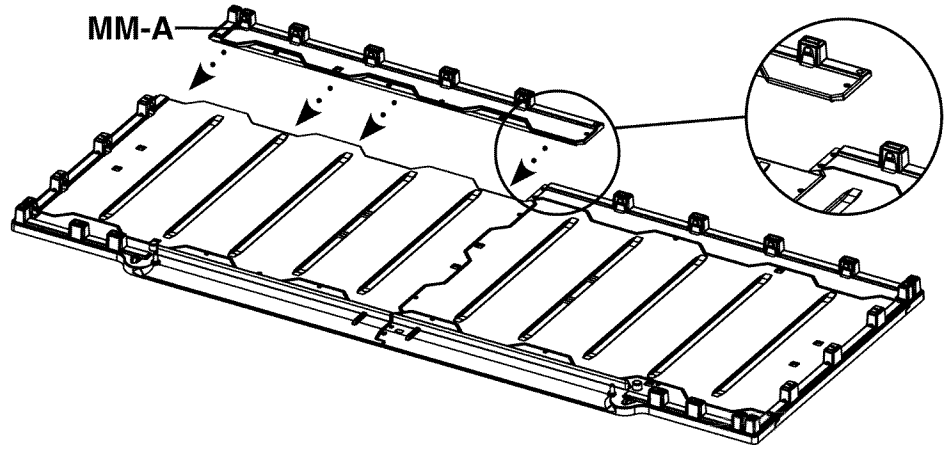

Anchor holes in each floor panel

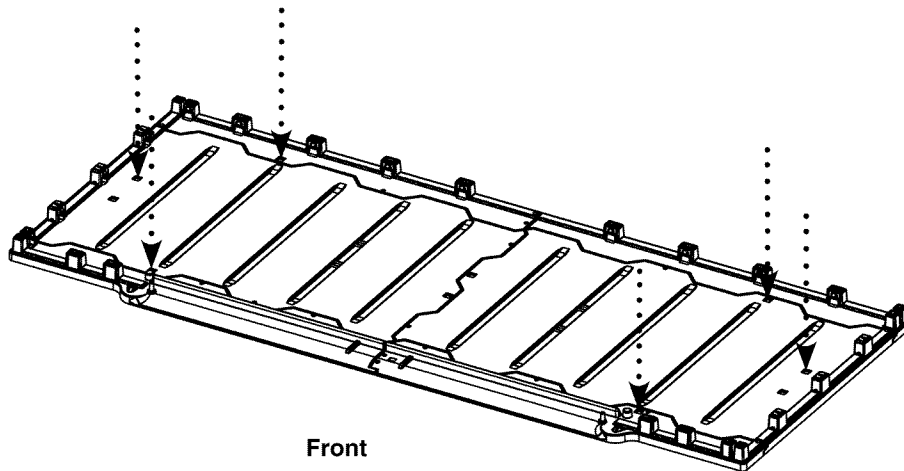

8. To anchor completed floor to foundation (hardware not supplied with Shed kit):

- Consult your local retailer for help to determine the best anchoring method for your particular installation.
- To secure the shed to a concrete pad, use masonry fasteners available at your local retailer.
- To secure the shed to a wood platform, use 1/4" X 2" long lag screws with washers.
- To secure the shed to ground use 12" nails.
- See diagram for anchoring locations.

9. Place Female Corner Post G on a flat surface with the embossed G facing up.

Hold Male Corner Post H above Female Corner Post G, making sure the hook end of Male Corner Post H is at one end and the embossed G of Female Corner Post G is at the other end.

Align male and female parts and insert H into G.

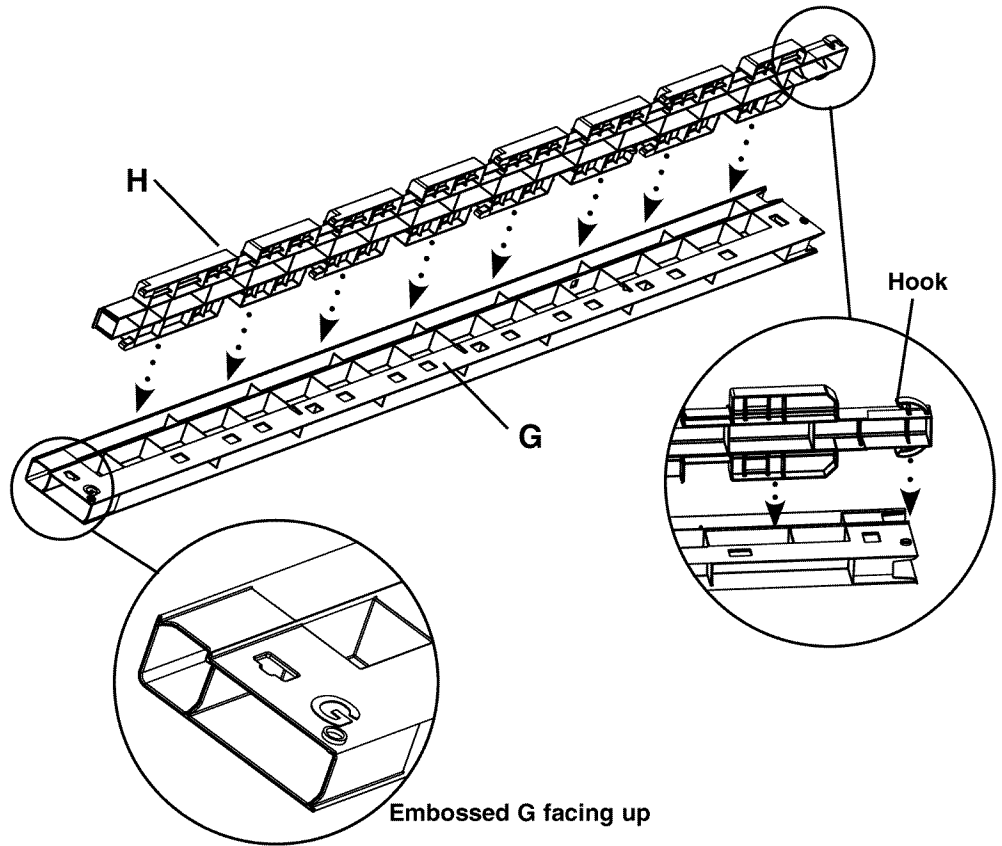

10. Slide Male Corner Post H down Female Corner Post G until parts snap in place.

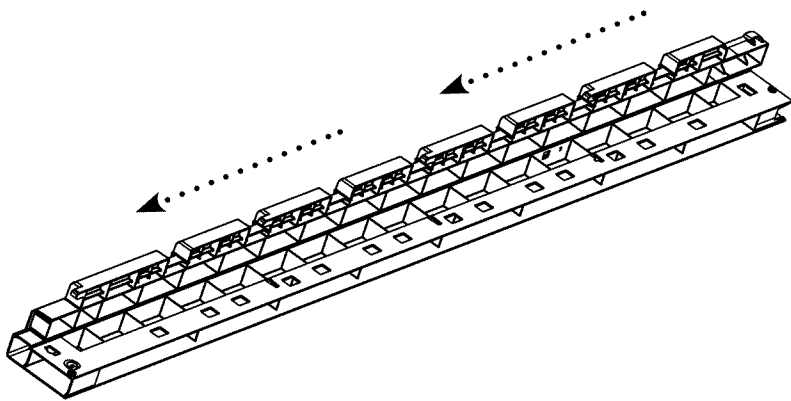

11. Assembled G/H Corner Post.

Repeat process to assemble other 3 corner posts. When complete, set Corner Post Assemblies G/H aside for later use.

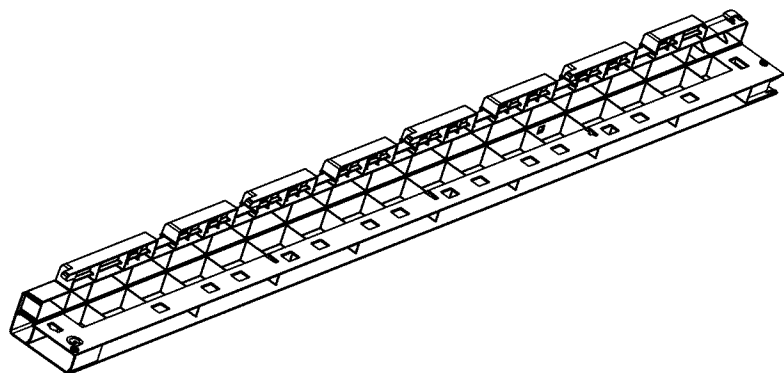

12. Place Front Panel A-A on flat surface.

Place Left Hinge Post P next to Front Panel A-A. Align male and female parts and insert A-A into P.

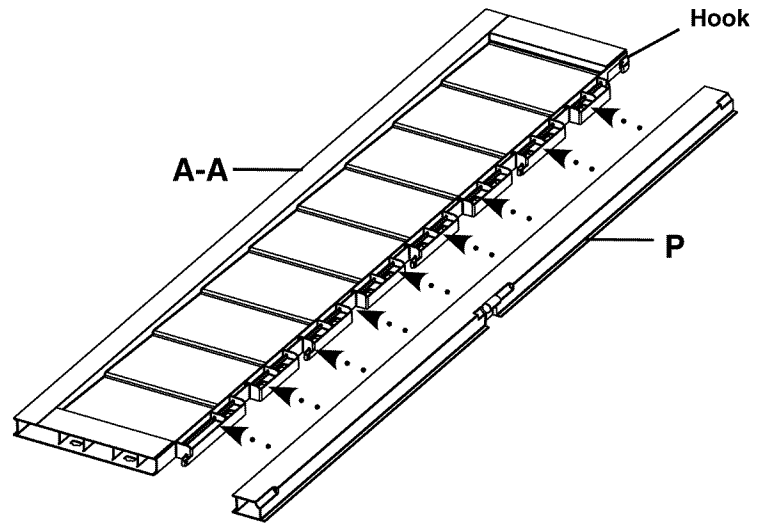

13. Slide Left Hinge Post P up Front Panel A-A until parts snap in place.

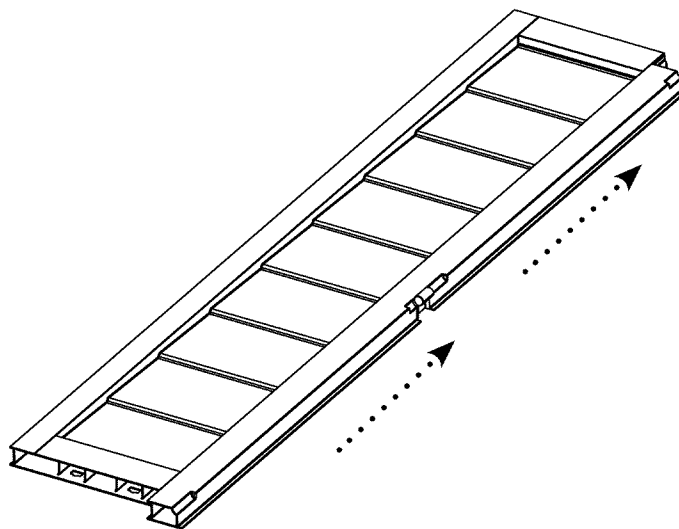

14. Assembled Left Front Panel A-A/P.

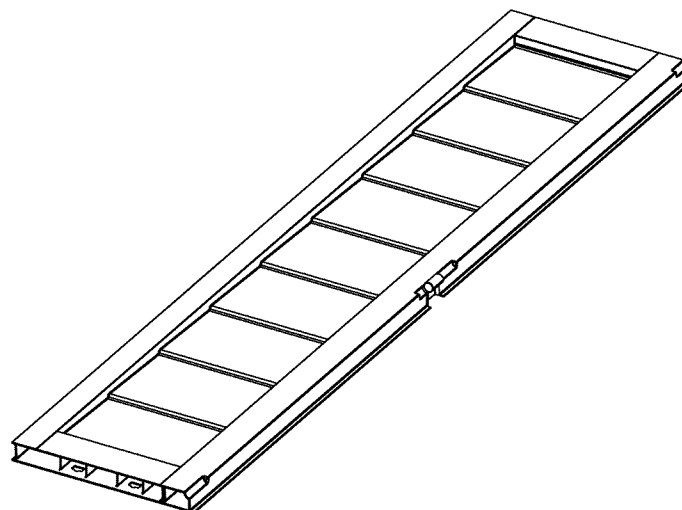

15. Align assembled Left Front Panel A-A/P with left front Floor to Front Connector JJ-A. **Do Not place A-A/P over corner post in JJ-A.**

Snap into place.

When complete, have a second person hold panel in upright position to prevent it from falling over.

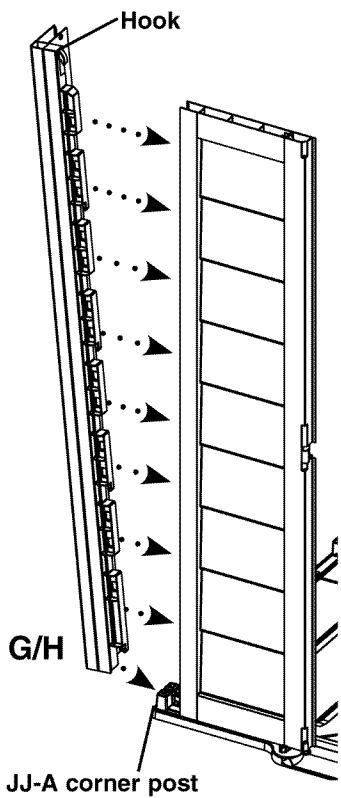
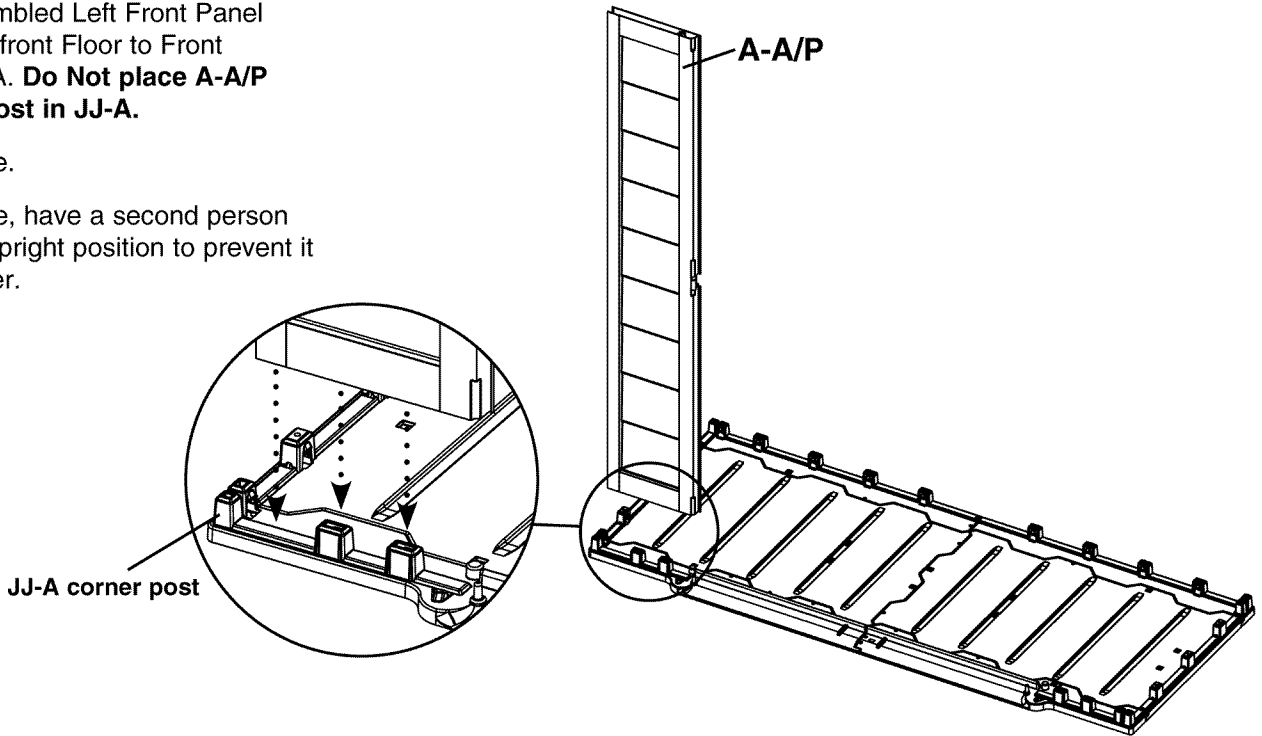

16. With Hook end up, align bottom of Corner Post Assembly G/H with corner post in Floor to Front Connector JJ-A.

Rotate G/H until male parts are inserted into Left Front Panel.

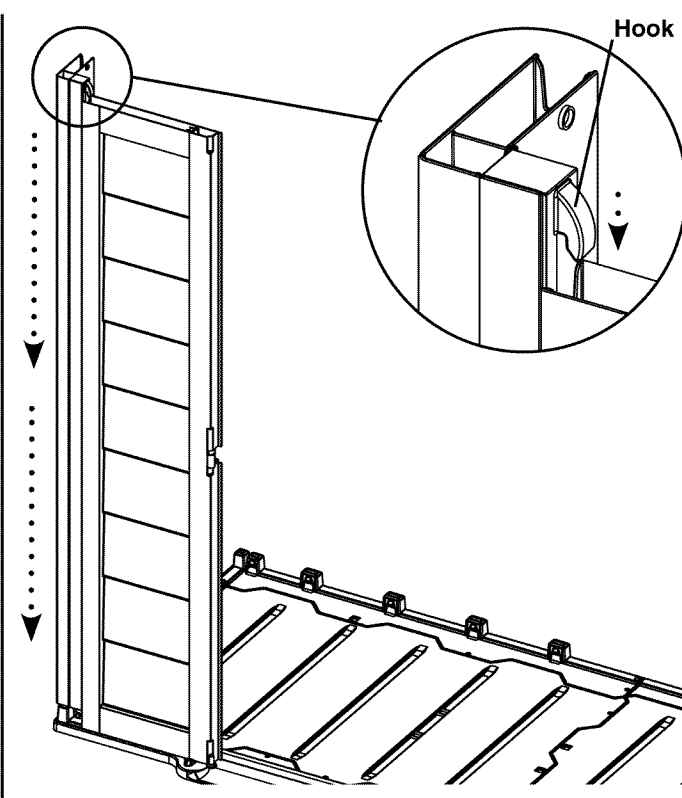

17. Slide Corner Post Assembly G/H down Front Panel A-A/P. Make sure the hook of the Corner Post Assembly hooks over the wall of Panel A-A/P and push down to snap in place.

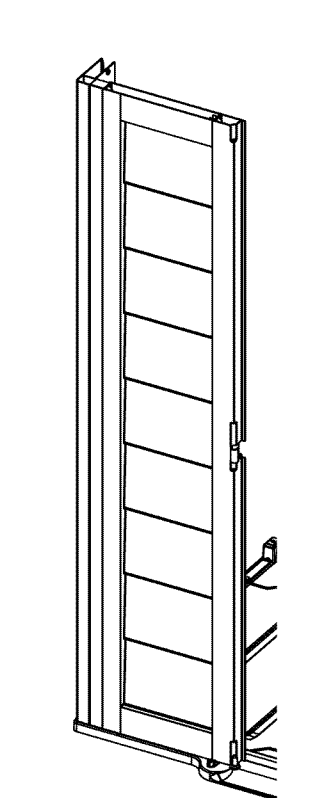

18. Assembled Left Front Panel and Corner Post.

19. Take one S Panel, and place it so the Hook is on top and facing Corner Post Panel G.

Align male and female parts; make sure the hook on Panel S hooks over the wall of Corner Post G/H, and push down to snap in place.

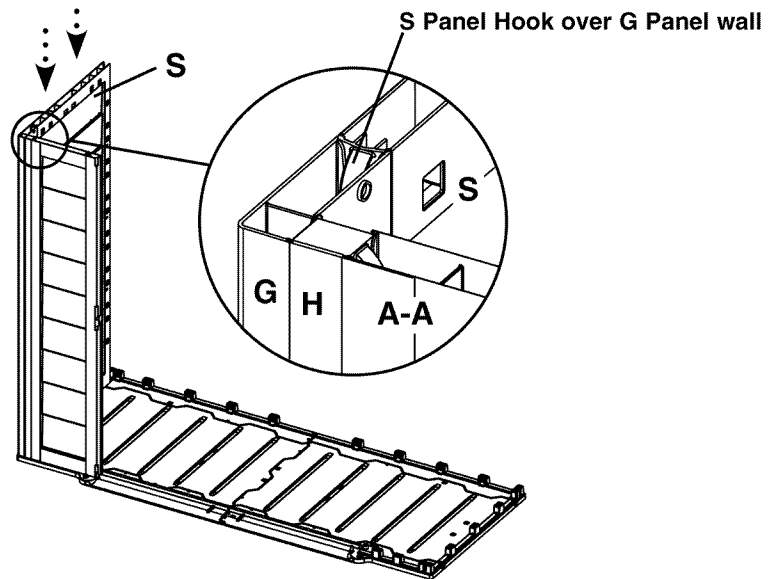

20. With hook end up, align second assembled Corner Post with Side Panel S. Align male and female parts and insert assembled Corner Post into S.

Slide assembled Corner Post down Side Panel S, making sure the hook of the assembled Corner Post hooks over the wall of Panel S and push down to snap in place.

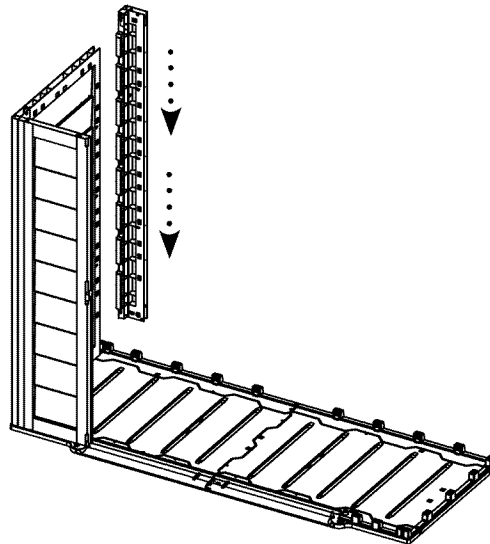

21. Take one S Panel and place it so the hook is on top and faces Corner Post G/H.

Align male and female parts. Make sure the hook on Side Panel S hooks over the wall of Corner Post G/H and push down to snap in place.

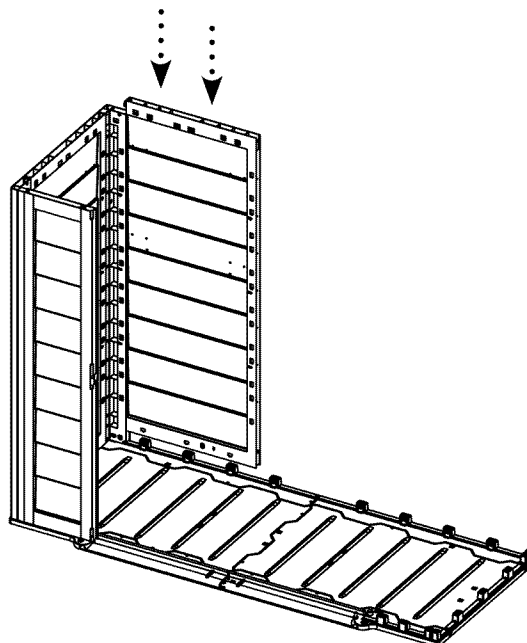

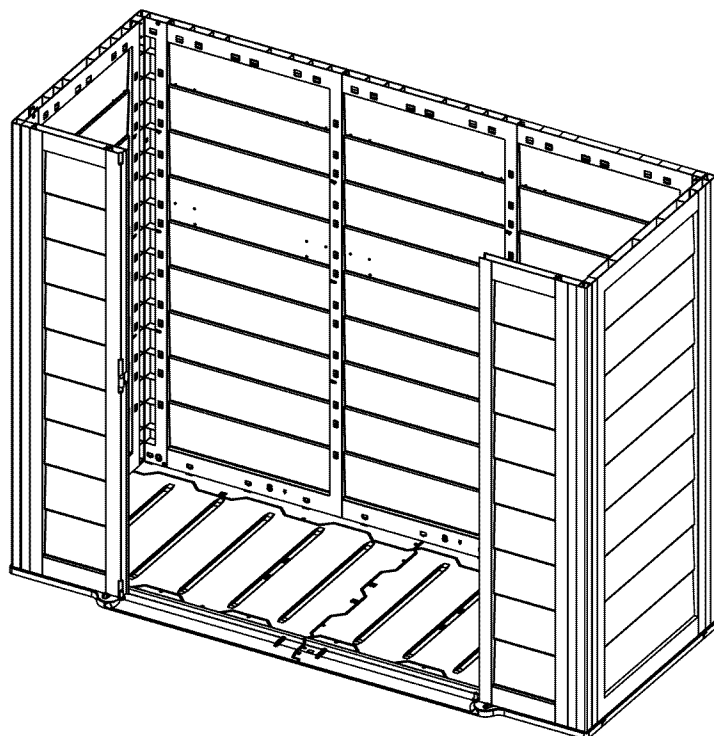

22. Complete side and corner assembly process. The remaining Front Panel A-A will be the last panel installed.

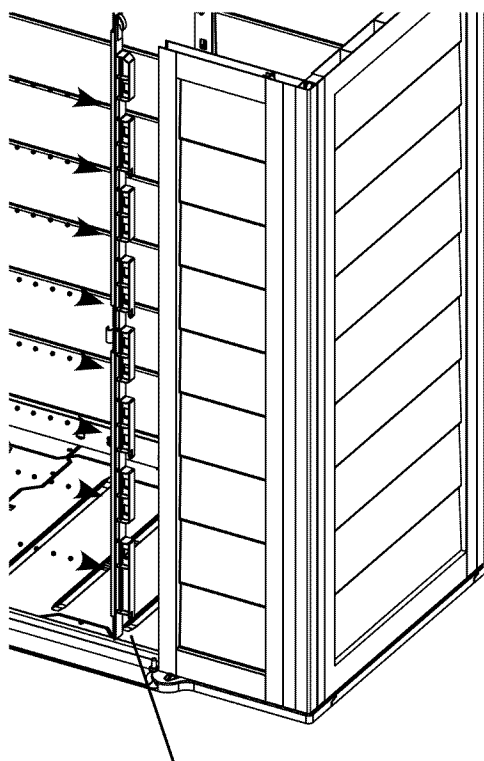

L

23. With Hook end up, place Right Hinge Post L next to Right Front Panel A-A. Align male and female parts and insert L into A-A.

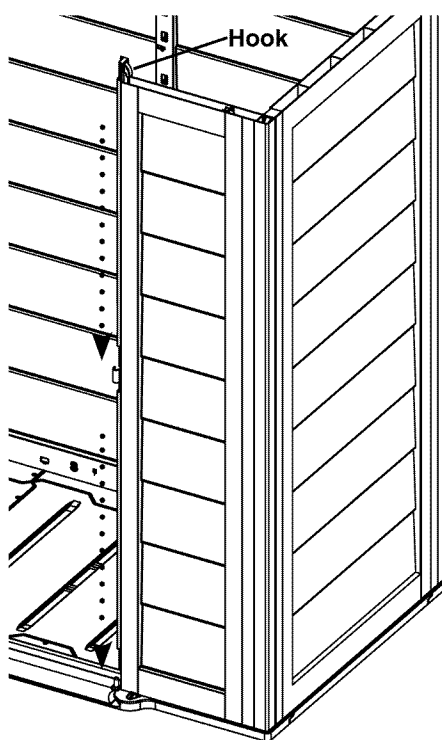

Hook

24. Slide Right Hinge Post L down Front Panel A-A. Make sure the hook at the top of the Right Hinge Post hooks over the wall of Panel A-A and push down to snap in place.

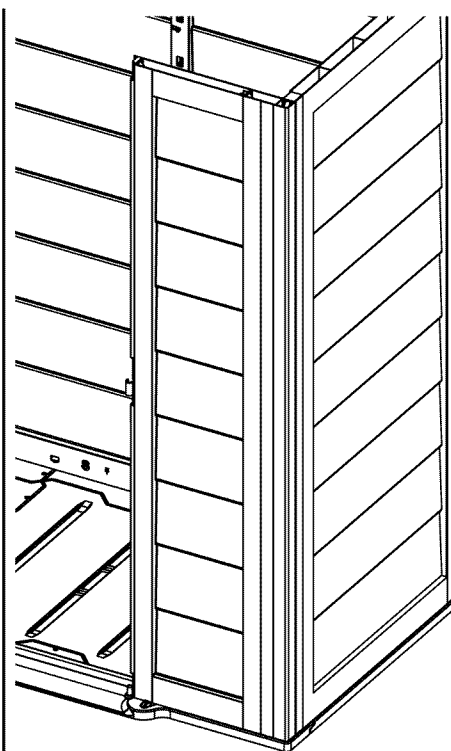

25. Assembled Right Front Panel and Hinge Post A-AL.

26. Make sure that all panels are securely in place.

Check all snaps to verify they are fully engaged.

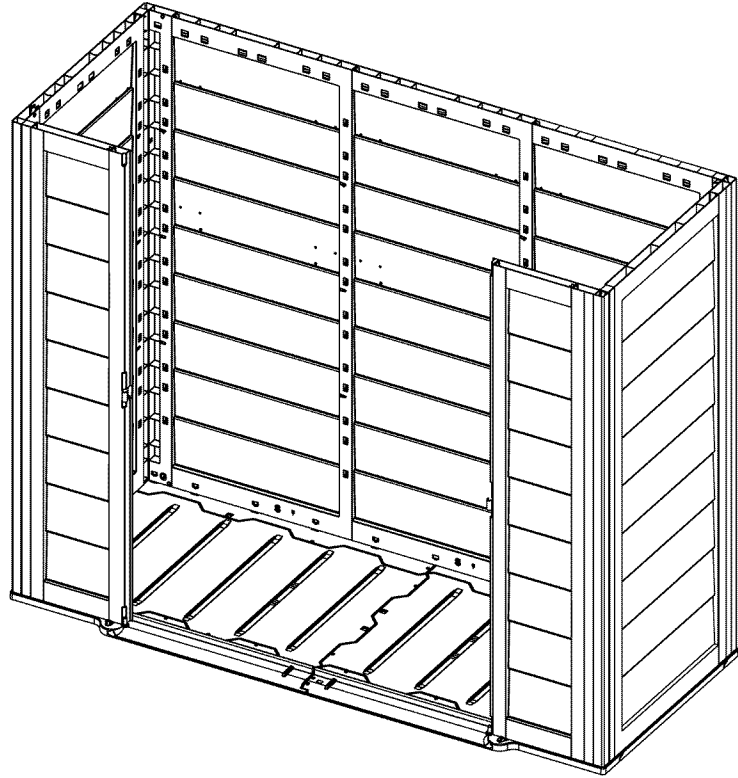



27. Standing inside shed, locate the Header Support Tube Bracket receptacles midway up from the floor on Front Panel A-A/L.

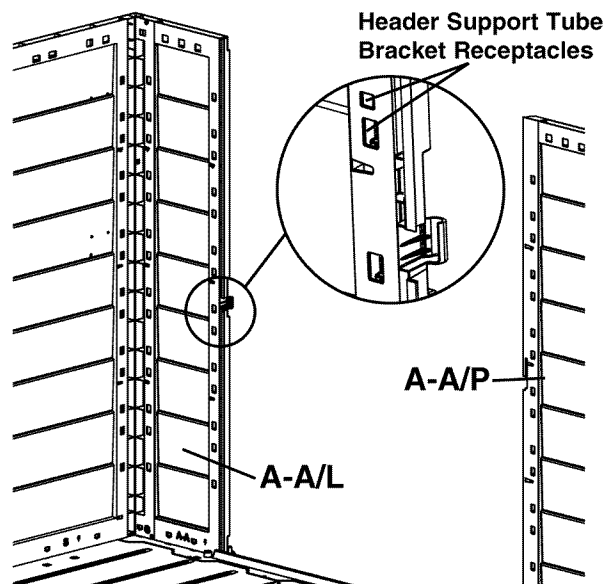

28. Align Header Support Tube Bracket tabs with receptacles in Panel A-A/L.

Engage the tabs into the two holes in Panel A-A/L and rotate the Bracket downward to snap into place.

Repeat process for second Header Support Bracket in Hinge Panel A-A/P, on other side of doorway.

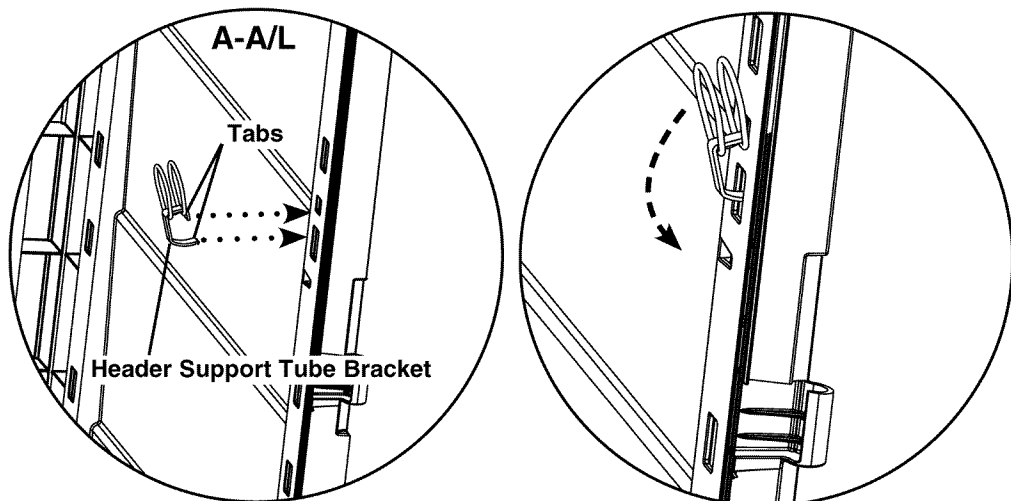

**NOTE: Use Caution when handling the Header Support Tubes, especially if other people are nearby. The tubes are long and if not handled with care can cause damage to persons or property.**

29. Slide Header Support Tube down through Header Support Tube Bracket and over floor post.

Repeat process for second Header Support Tube.

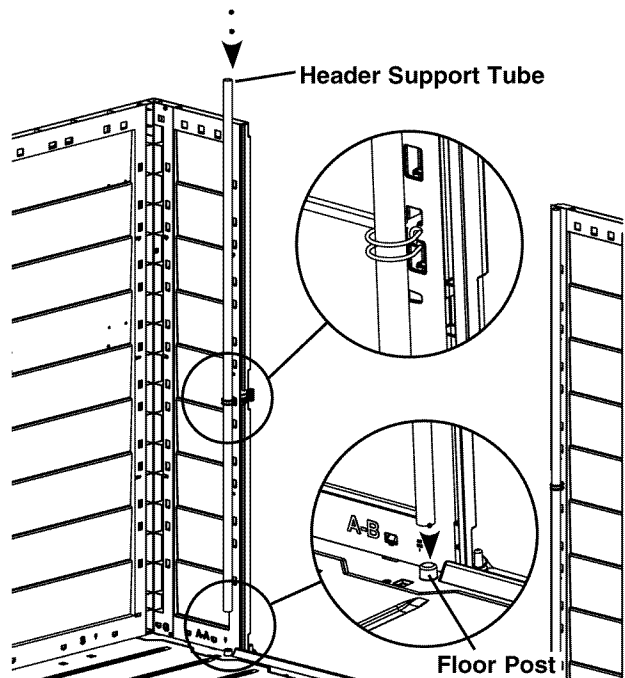

30. To insert Door Latch Housings M, position Tabs so they point towards the edge of the door. Place the Tabs behind the front wall of the door and press until part snaps in place.

Repeat process for second Door Latch Housing M.

**NOTE: Door Latch Housings can only be inserted in one direction.**

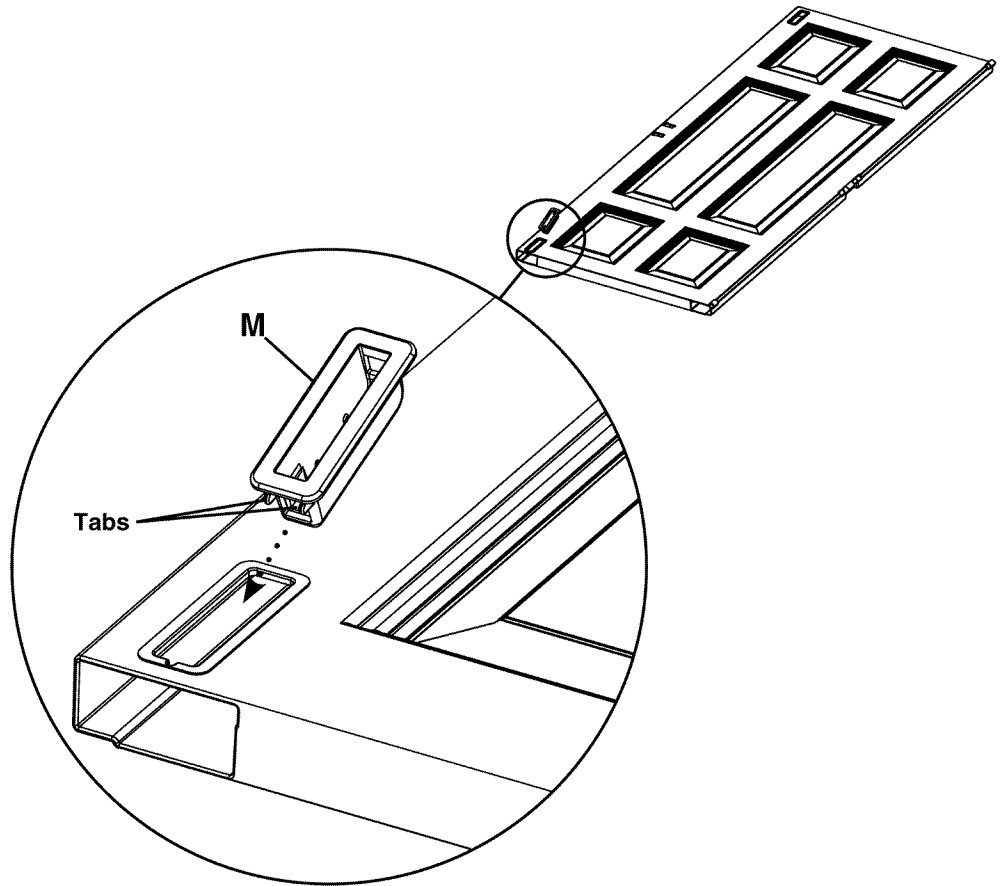

31. Insert square end of Door Latch Pin N into Door Latch Housing M.

**For the Door Latch Housing at the BOTTOM** of the door you will push the pin **UP** into the Door Latch Housing.

Once square end is inserted, push Door Latch Pin N **downward** to engage snaps that secure it inside housing.

**For the Door Latch Housing at the TOP** of the door you will push the pin **DOWNWARD** into the Door Latch Housing.

Once square end is inserted, push Door Latch Pin N **upward** to engage snaps that secure it inside housing.

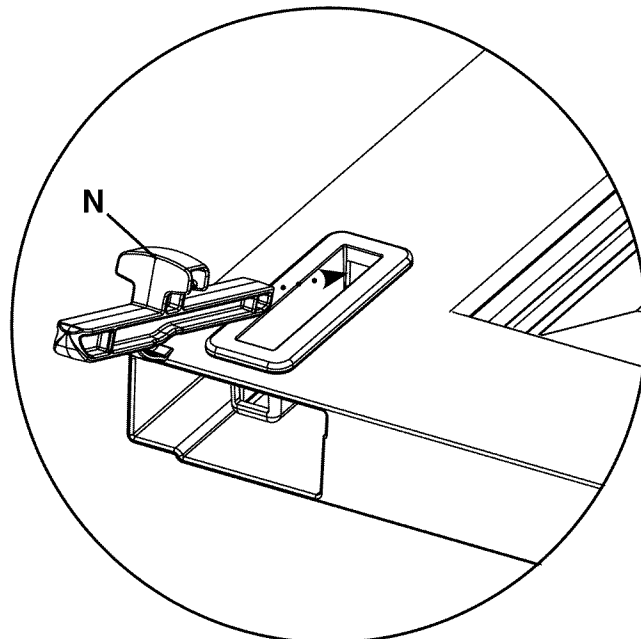

Door Latch Housing at the **BOTTOM** of the door

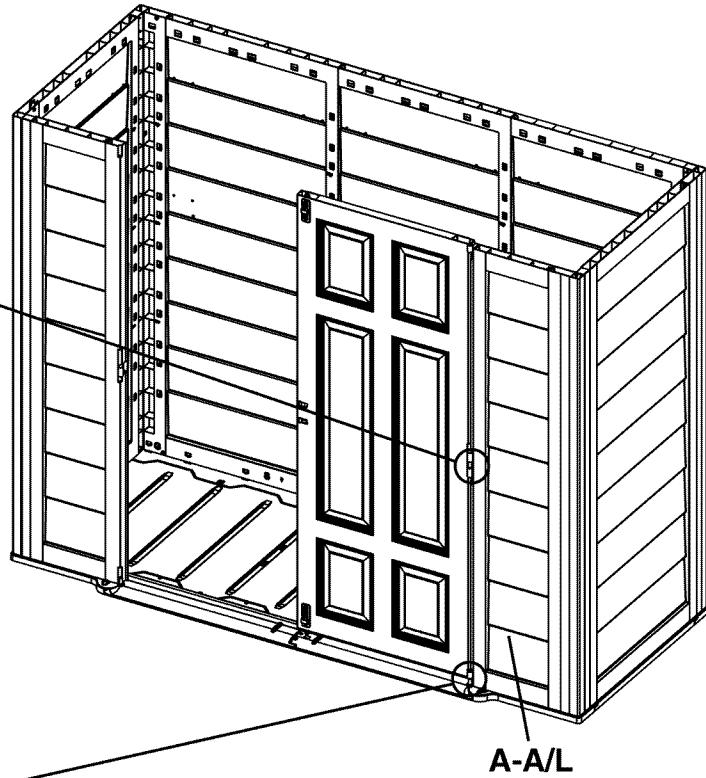
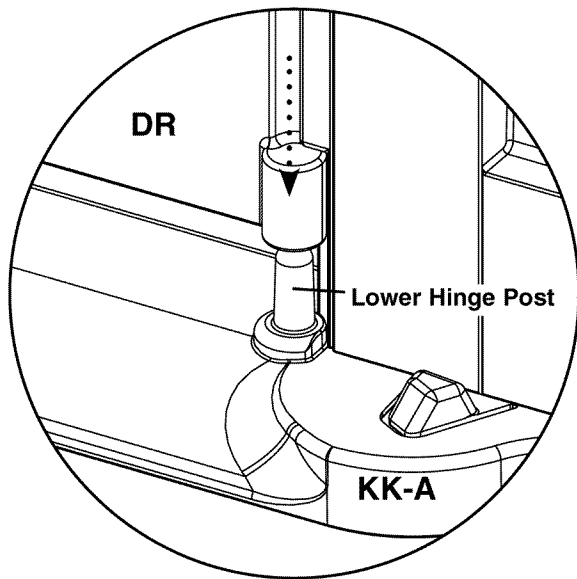
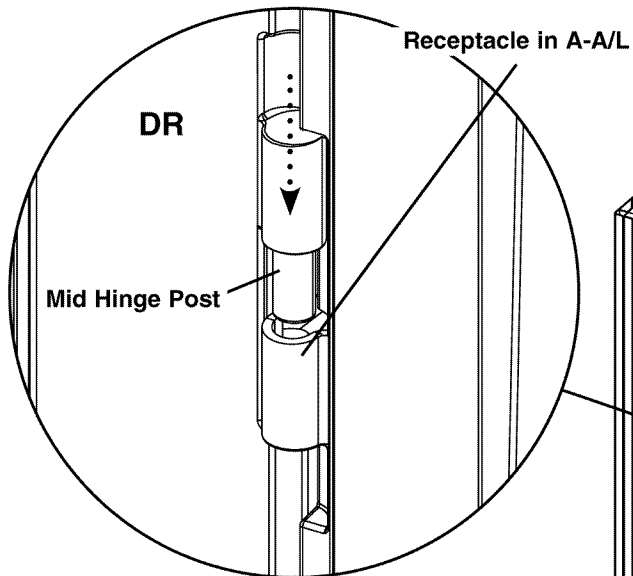

32. With Door DR in the closed position, align Mid Hinge Post with receptacle in Assembled Right Front Panel A-A/L. At the same time, align Lower Hinge Post of Front Connector KK-A with receptacle in Right Door DR and slide down into place.

33. With Right Door in open position, repeat process for Left Door DL.

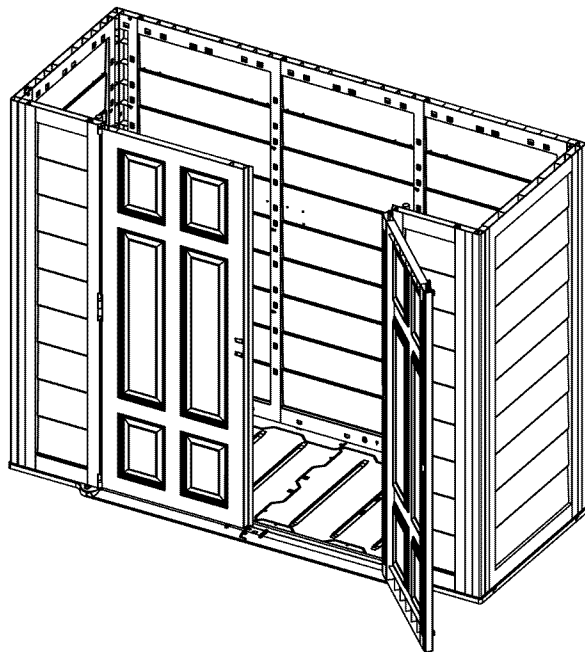

34. Align male and female ends of Header Panels EL and ER. Slide together until the panels snap in place.

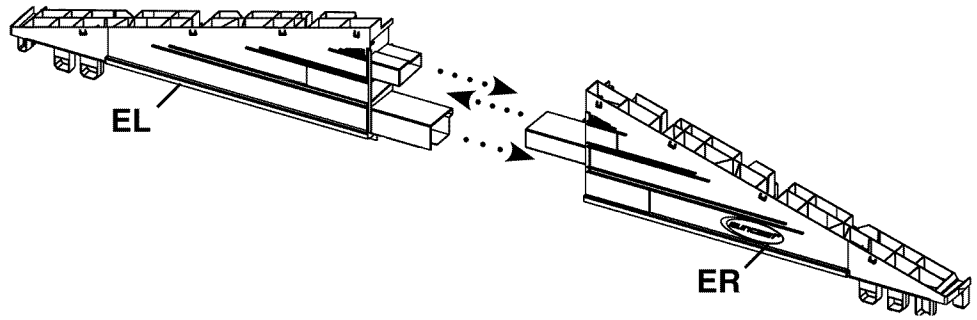

Repeat for second header.

Underside View of Assembled Header

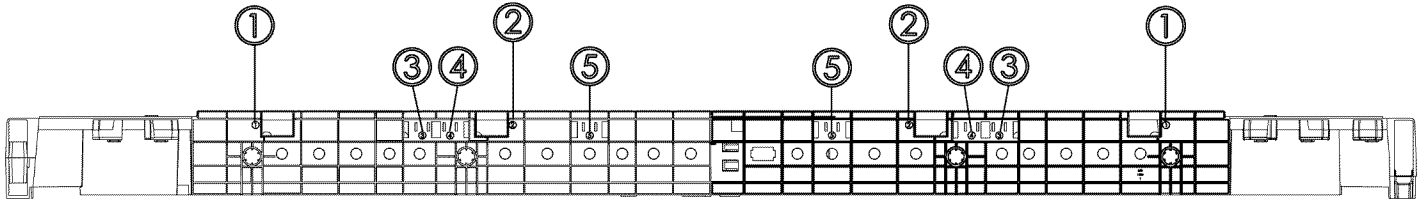

Back to Header Connector R and Hinge Pin DD positions are located by numerals 1 through 5 on the underside of the completed headers.

Not every numeral position will be used.

Please follow the directions closely to ensure the proper positions are used.

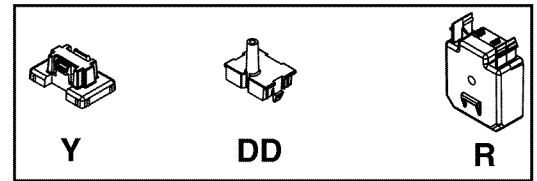

Header to Header Connector Y is placed in an unnumbered location where the two headers meet.

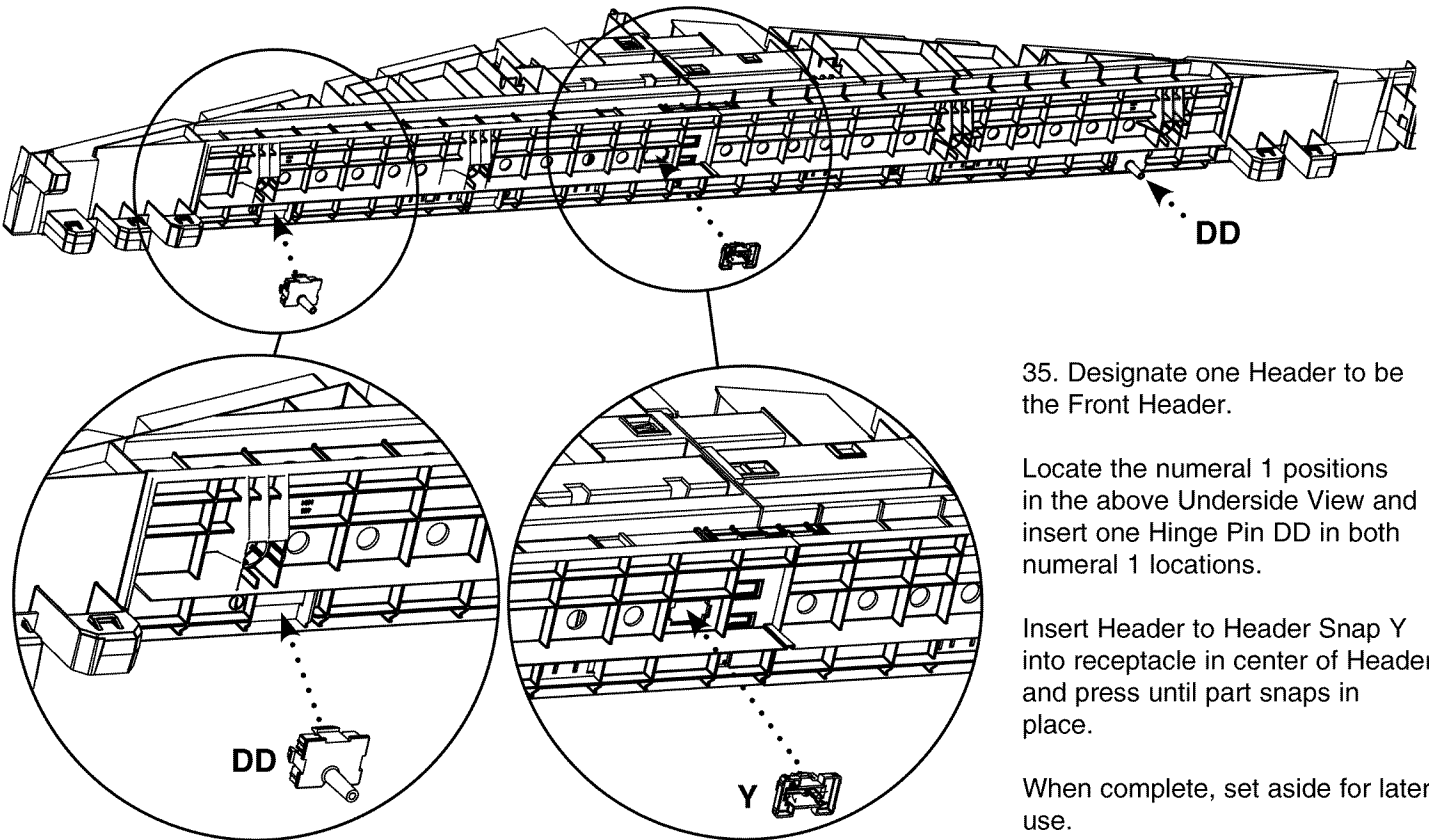

35. Designate one Header to be the Front Header.

Locate the numeral 1 positions in the above Underside View and insert one Hinge Pin DD in both numeral 1 locations.

Insert Header to Header Snap Y into receptacle in center of Header and press until part snaps in place.

When complete, set aside for later use.

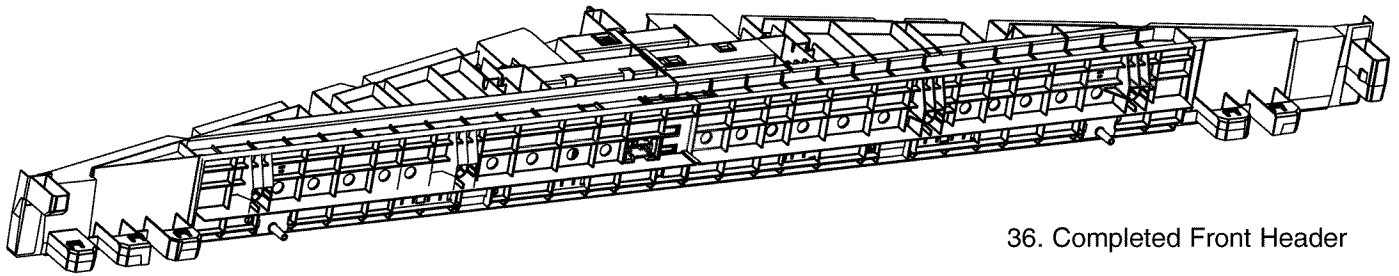

36. Completed Front Header

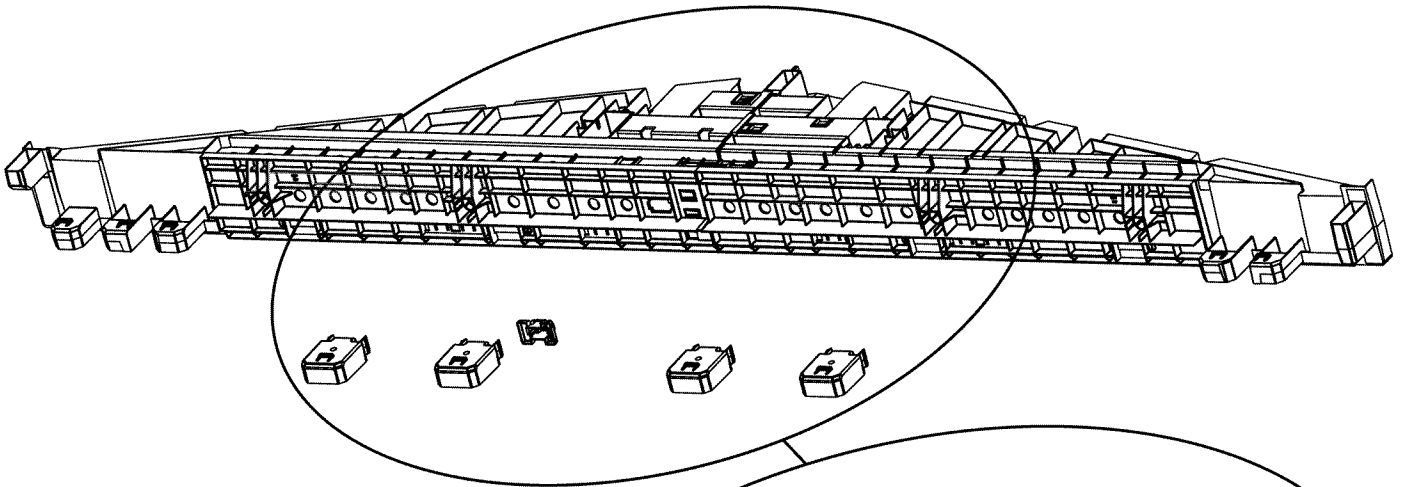

37. The remaining Header is the Back Header.

Locate the numeral 4 and 5 positions in the Underside View on page 20 and insert one Back to Header Connector R in both numeral 4 locations and both numeral 5 locations.

Insert Header to Header Snap Y into receptacle in center of Header and press until part snaps in place.

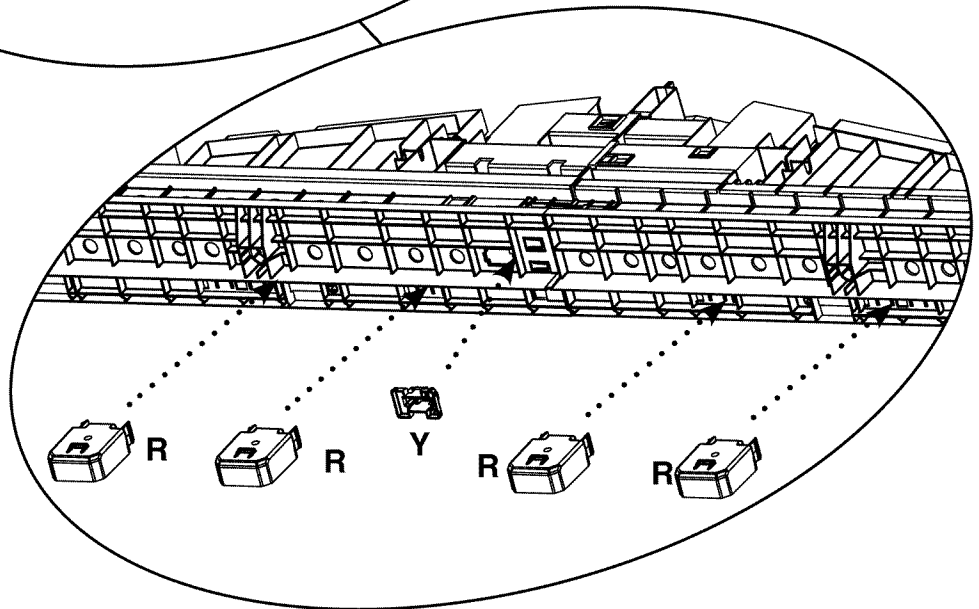

When complete, set aside for later use.

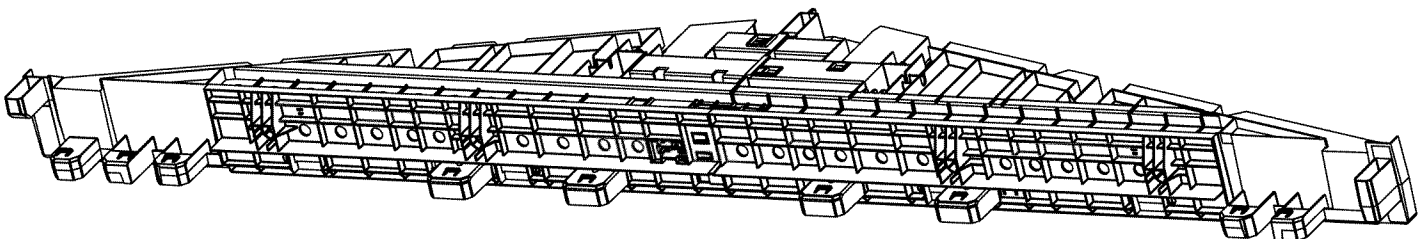

38. Completed Back Header

**NOTE:** Make sure you have the Front Header in the Front of the Shed and the Back Header in the Back of the Shed.

39. With at least two people, both standing inside the shed, lower Back Header into place.

**Do not engage Back Header snaps at this time.**

See next two steps for details specific to each Header installation.

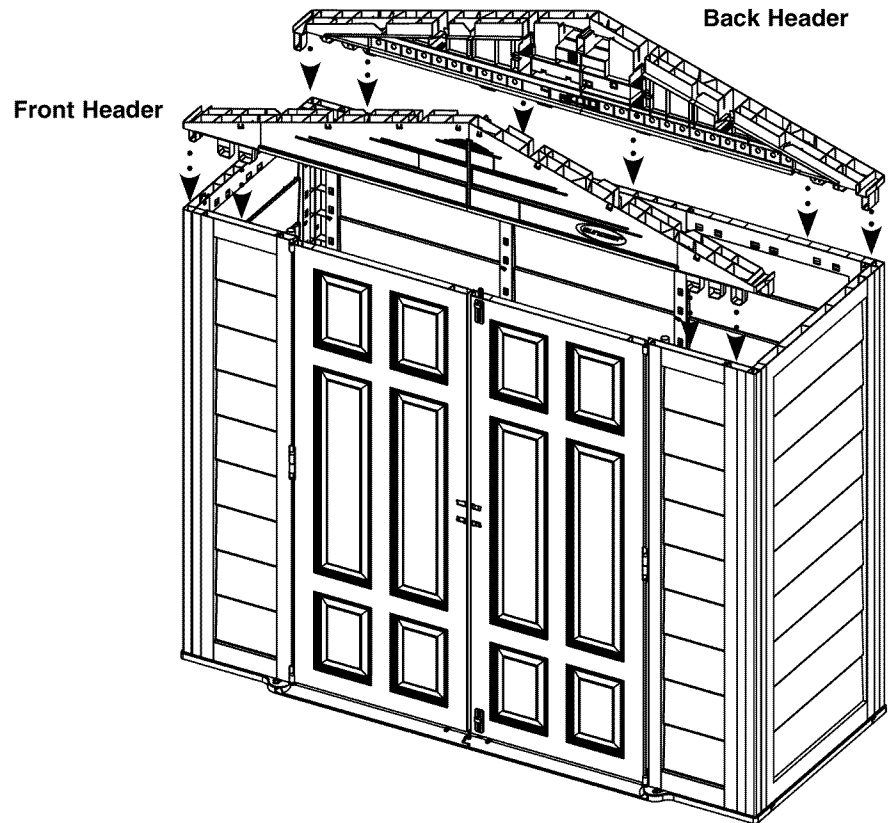

### Back Header to Shed

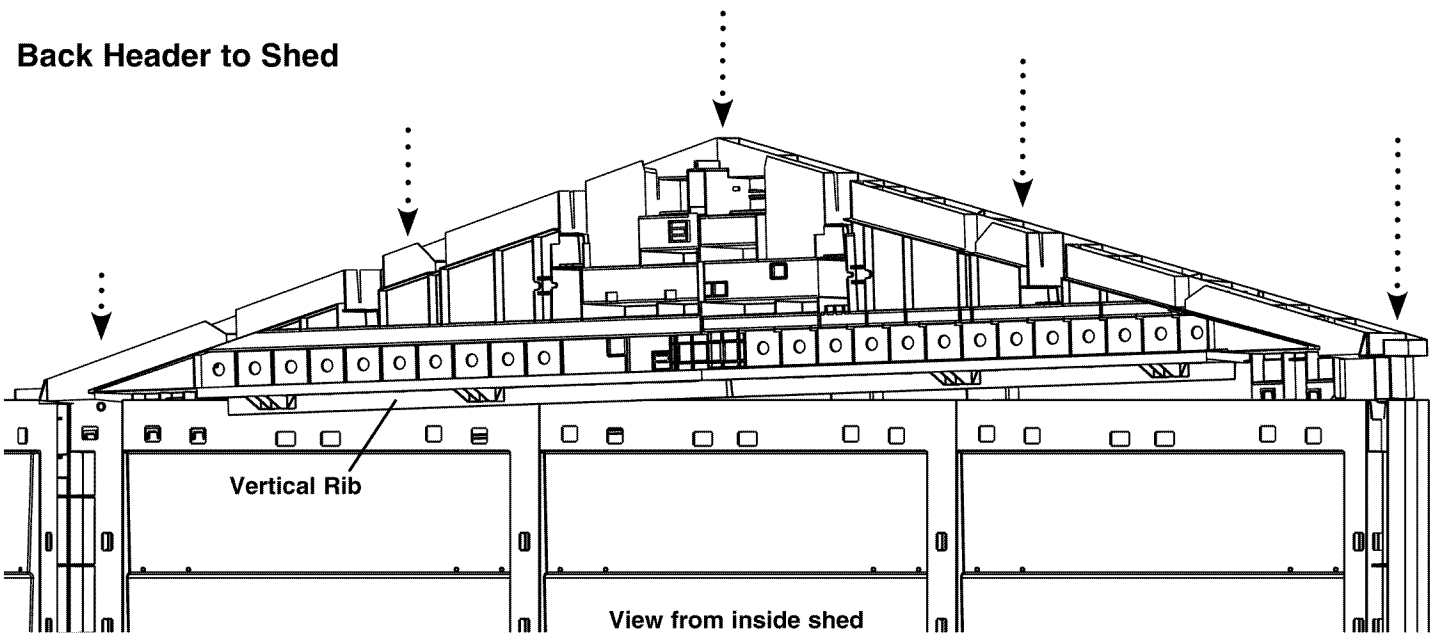

40. From one end, start inserting the Back Header partially into the Side Panels that make up the back of the shed. Begin final installation by pressing downward on one end of the Header.

Guide the vertical rib to the inside of the shed as you move along the Header to the other end. Continue until all snaps are in place.

## Front Header to Shed

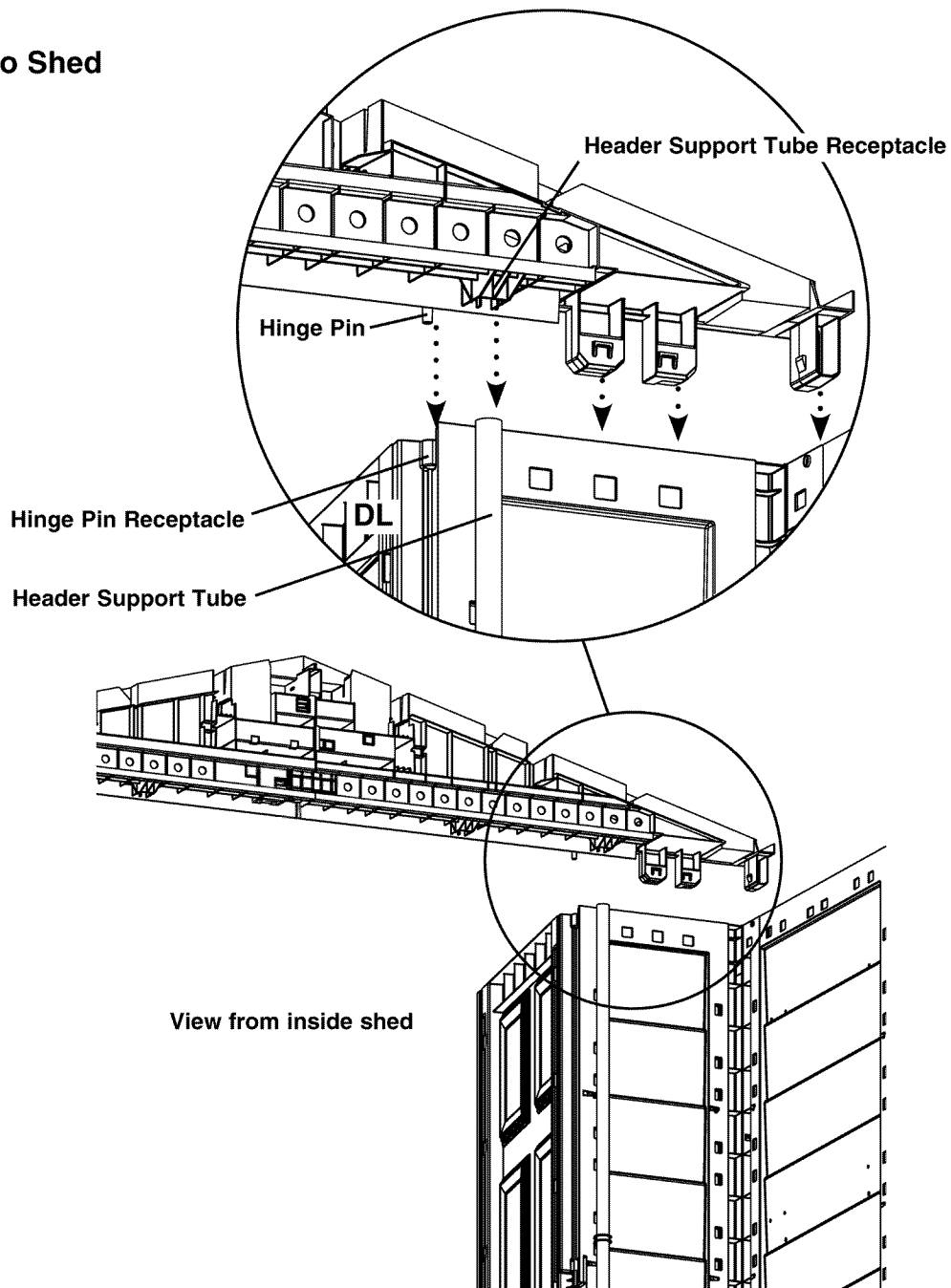

41. Set Doors in open position. With at least two people, one of them standing inside the shed, lower Front Header into place.

**Do not engage Front Header snaps at this time.**

Align Hinge Pins and Header Support Tube Receptacles in Front Header with Hinge Pin Receptacles and Header Support Tubes.

Begin final installation by pressing downward on one end of the Header and working your way to the other until all snaps are in place.

42. Make sure that both Headers are securely in place.

Check all snaps to verify they are fully engaged.

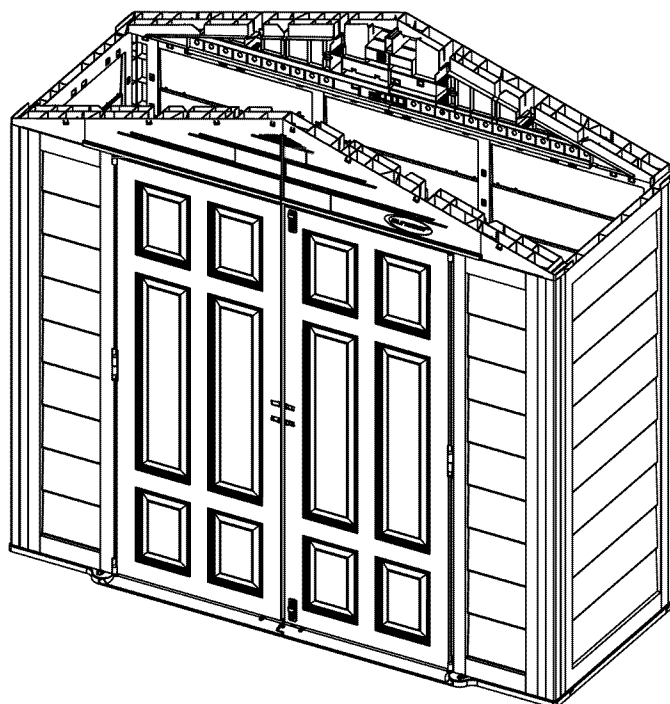

43. Insert one Roof to Side Connector U into each Side Panel. Snap in place.

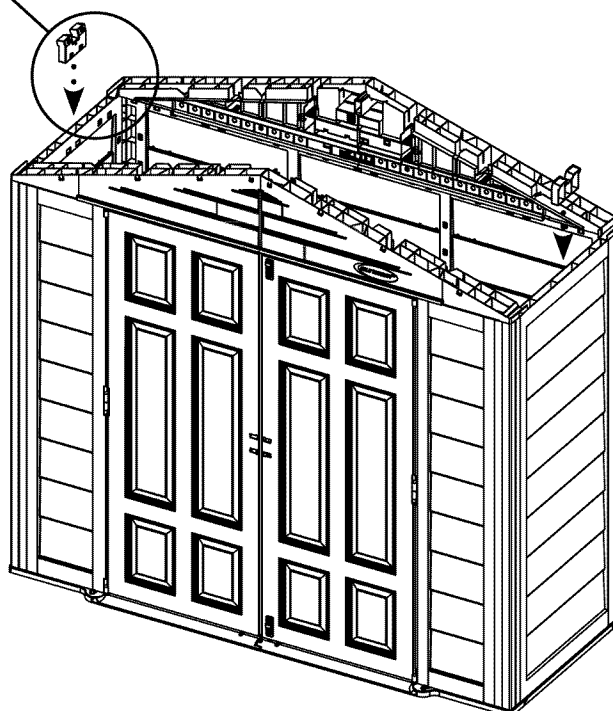
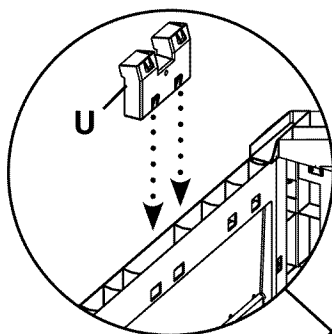



**NOTE: Use Caution when handling the Steel Ridge Beam, especially if other people are nearby. The beams can cause damage to persons or property if not handled with care.**

44. Standing inside the shed, insert one end of the Steel Ridge Beam into the rectangular boss in the **center** of the Rear Header.

Still standing inside shed, **support the Steel Ridge Beam** and push outward slightly on the Front Header to insert opposite end into the rectangular boss in the center of the Front Header.

Once Beam is in place **DO NOT** push outward on either header, as Beam may fall.

**DO NOT** stand beneath Beam until Assembled Ridge Panels are in place.

Rectangular boss in center of Rear Header

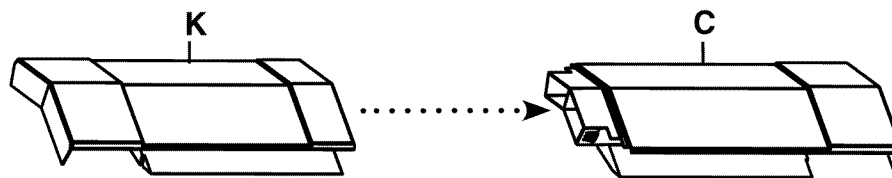
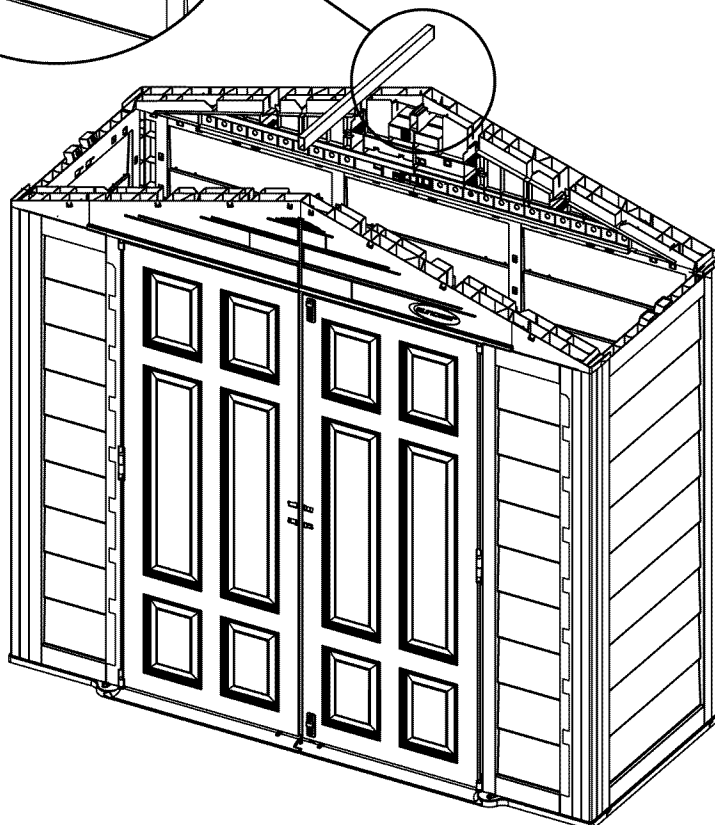
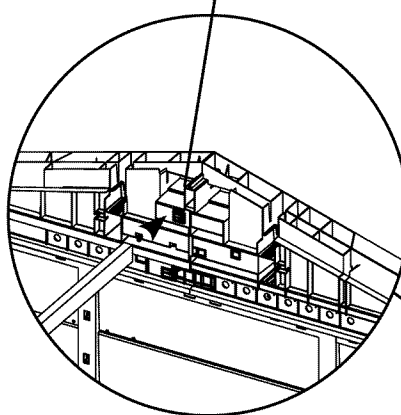

45. Align Female Ridge End K with Male Ridge End C and snap together.

Once Beam is in place **DO NOT** push outward on either Header, as Beam may fall.

**DO NOT** stand beneath Beam until Assembled Ridge Panels are in place.

46. Lift the assembled Ridge Panels over the center Steel Ridge Beam and lower into place. Line up Headers with Ridge Ends and snap together.

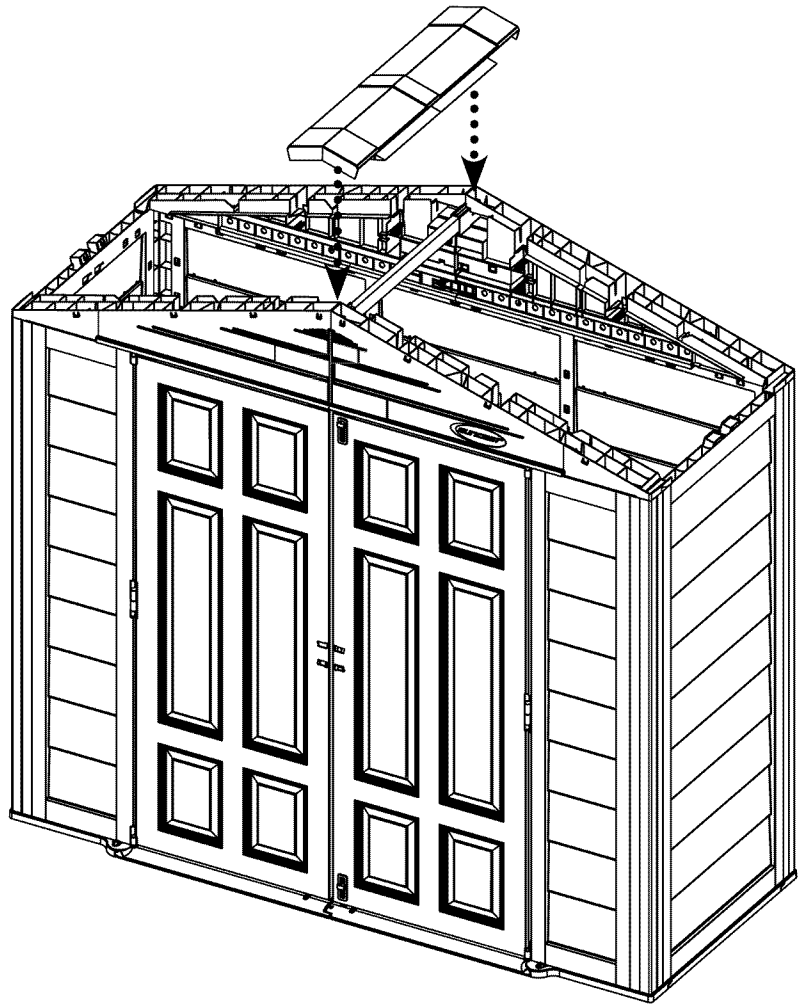

47. Make sure that both ends of Ridge Panels are securely in place.

Check all snaps to verify they are fully engaged.

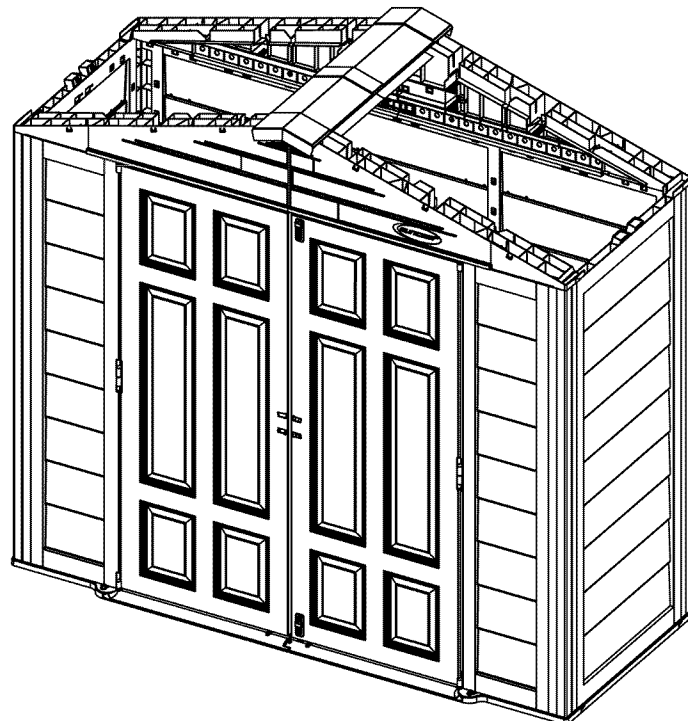

48. With at least two people, start in back left corner of shed and lift one Roof Panel CC-A into position.

Insert left corner of Roof Panel CC-A into the Ridge Assembly making sure that it straddles the Back Header.

Rotate Panel CC-A towards the right and push into Ridge Assembly to snap pieces together.

It may be necessary to have a helper on a step ladder at the back, outside of the shed to help guide the roof panel into the Ridge Assembly. A flat blade screwdriver can be used to open up the Ridge to accept the Roof Panel. Use caution to avoid pinching fingers.

**NOTE: Do not engage Roof Panel CC-A to Roof to Side Connector U at this time.**

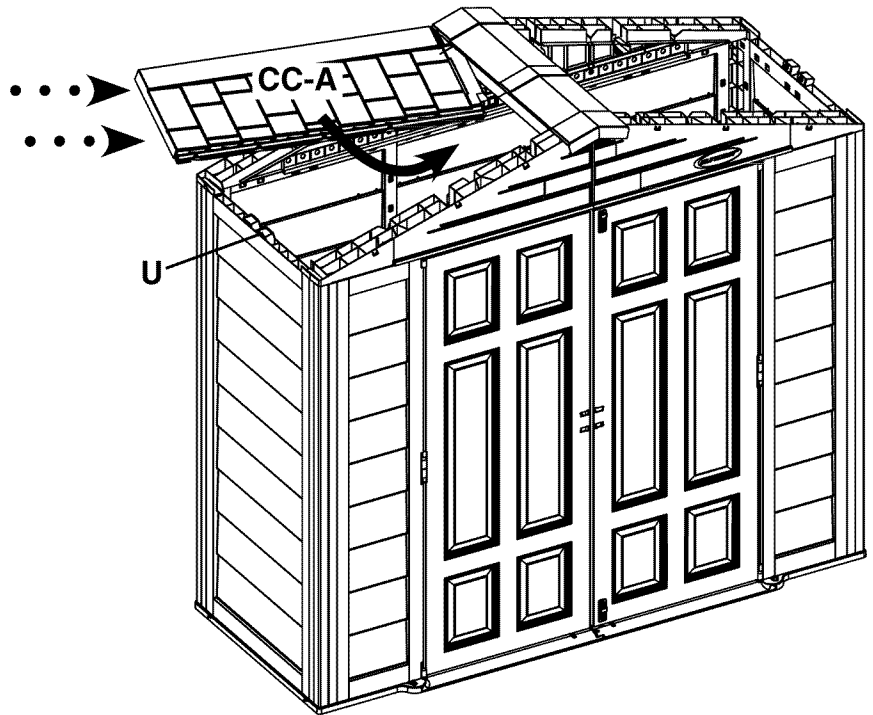

49. Once you have verified that the Ridge Assembly snaps have engaged, continue to push the Roof Panel down until Roof to Side Connector U snaps into holes in the underside of the Roof Panel CC-A.

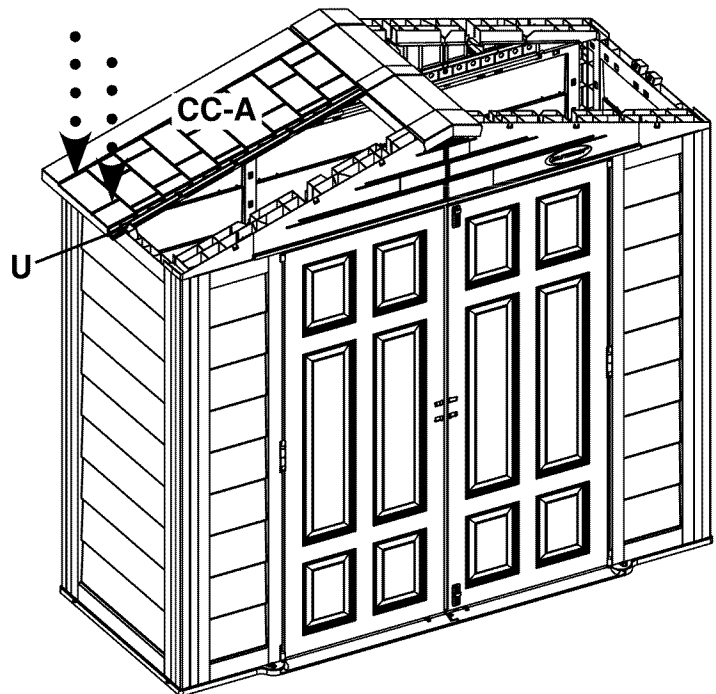

50. Repeat process for Roof Panel X-A.

It may be necessary to have a helper on a step ladder at the front of the shed to help guide the roof panel into the Ridge Assembly. A flat blade screwdriver can be used to open up the Ridge to accept the Roof Panel. Use caution to avoid pinching fingers.

Make sure that all Roof Panels and Connectors on left side are securely in place.

Check all connection points and snaps to verify they are fully engaged.

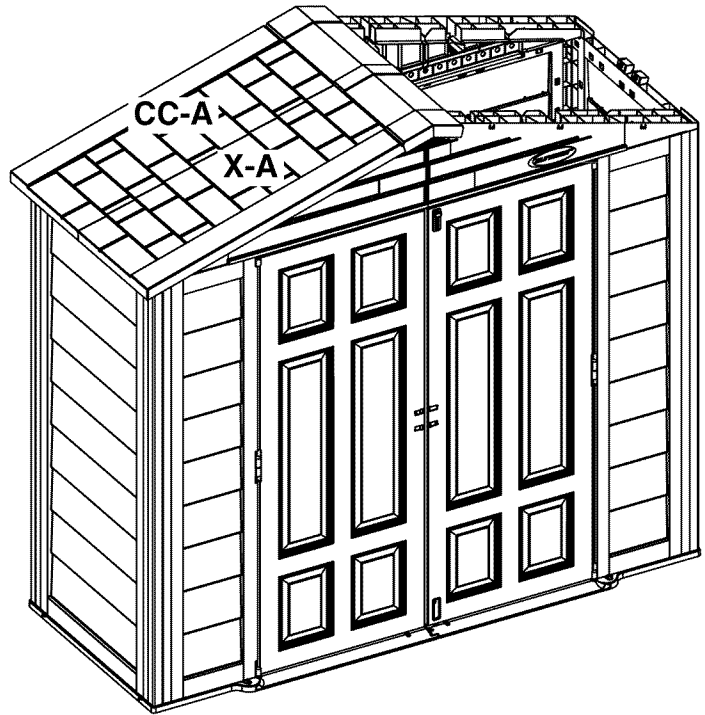

View inside shed looking up

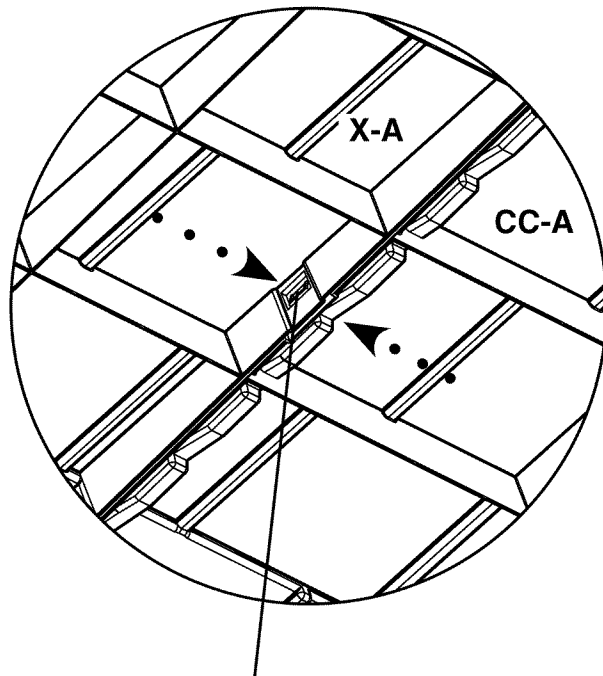

51. From inside the shed, locate the Roof Panel to Roof Panel Snaps and verify that they are fully engaged by queezing them together with your fingers.

Squeeze Roof Panel to Roof Panel Snap together to fully engage.

52. Repeat process for Right side of Shed.

Make sure that all Roof Panels and Connectors are securely in place.

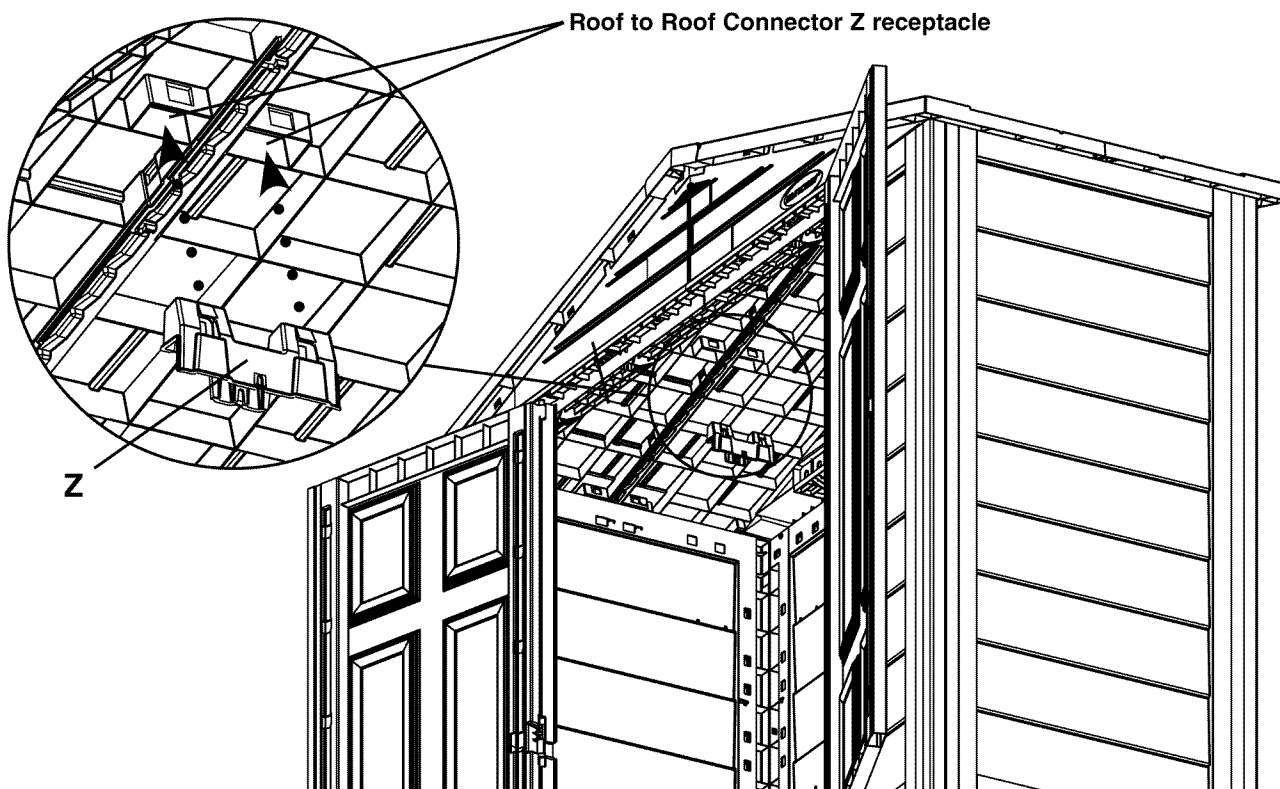
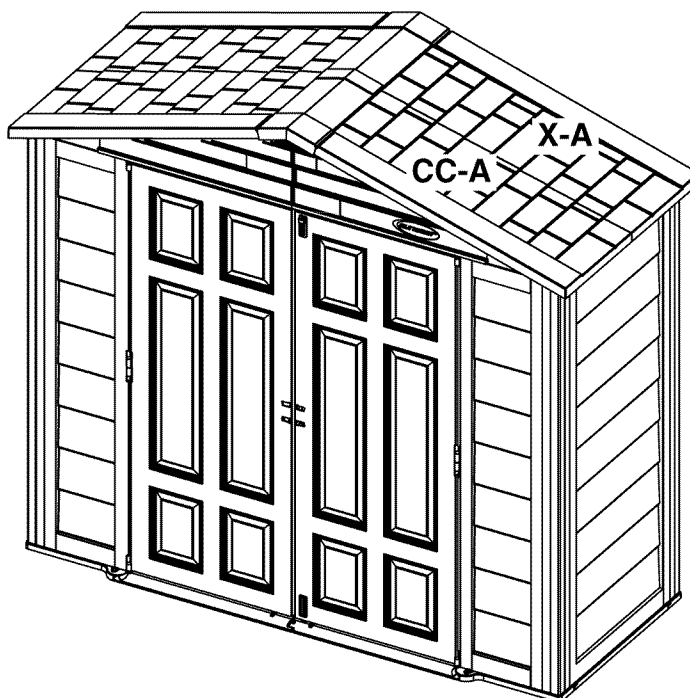

View inside shed looking up

53. Insert Roof to Roof Connector Z in the Roof to Roof Connector Z receptacle in the underside of Roof Panel CC-A and X-A.

Repeat process for Right side of Shed.

54. Align Left Door Handle W with corresponding holes in Left Door DL and insert.

Secure from back side of Left Door with provided #8-10 x 3/4" Pan Head screws.

**TIGHTEN SCREWS WITH A HAND SCREWDRIVER. DO NOT OVERTIGHTEN SCREWS.**

Repeat process for Right Door Handle T and Right Door DR.

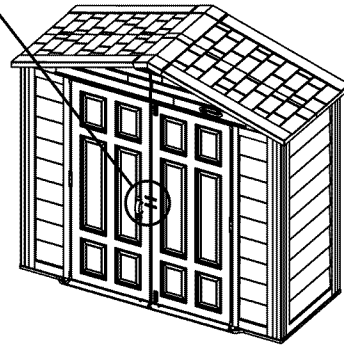
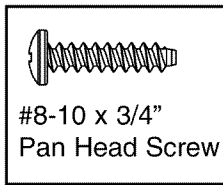
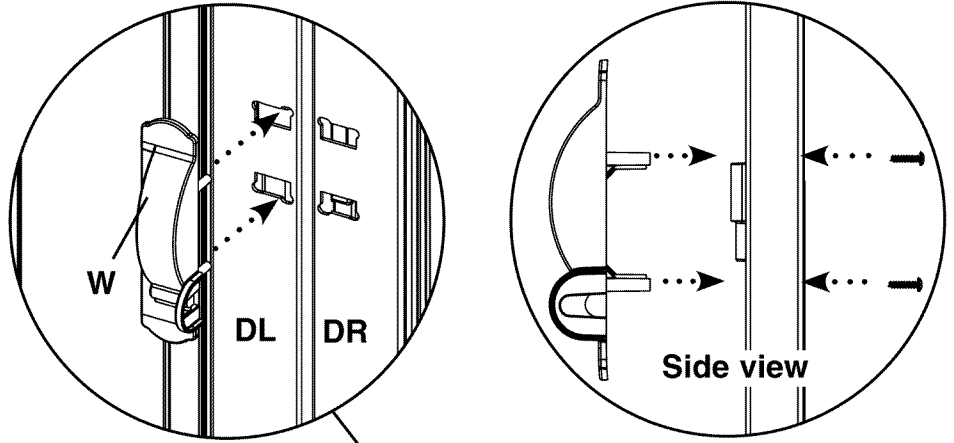

55. Make sure that all parts are securely in place.

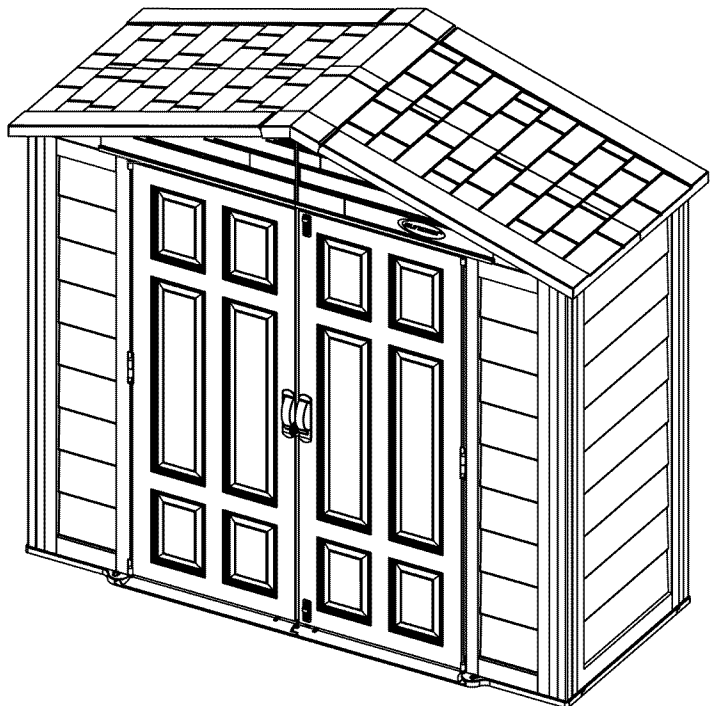

## Side Panel Support installation

**NOTE:** Use Caution when handling the Side Panel Supports, especially if other people are nearby. The Supports are long and if not handled with care can cause damage to persons or property.

**NOTE:** Side Panel Supports are installed where one Side Panel S attaches to another Side Panel S. Side Panel Supports cannot be used where a Side Panel and Corner Post Assembly meet.

56. Align hooks on back side of Side Panel Support with receptacles in connection seam of two Side Panels S.

Insert hooks into receptacles, making sure that the hooks pass through **both** Side Panels and slide down to set in place.

A small rubber mallet may be useful to tap the top of the Side Panel Support and ensure correct installation.

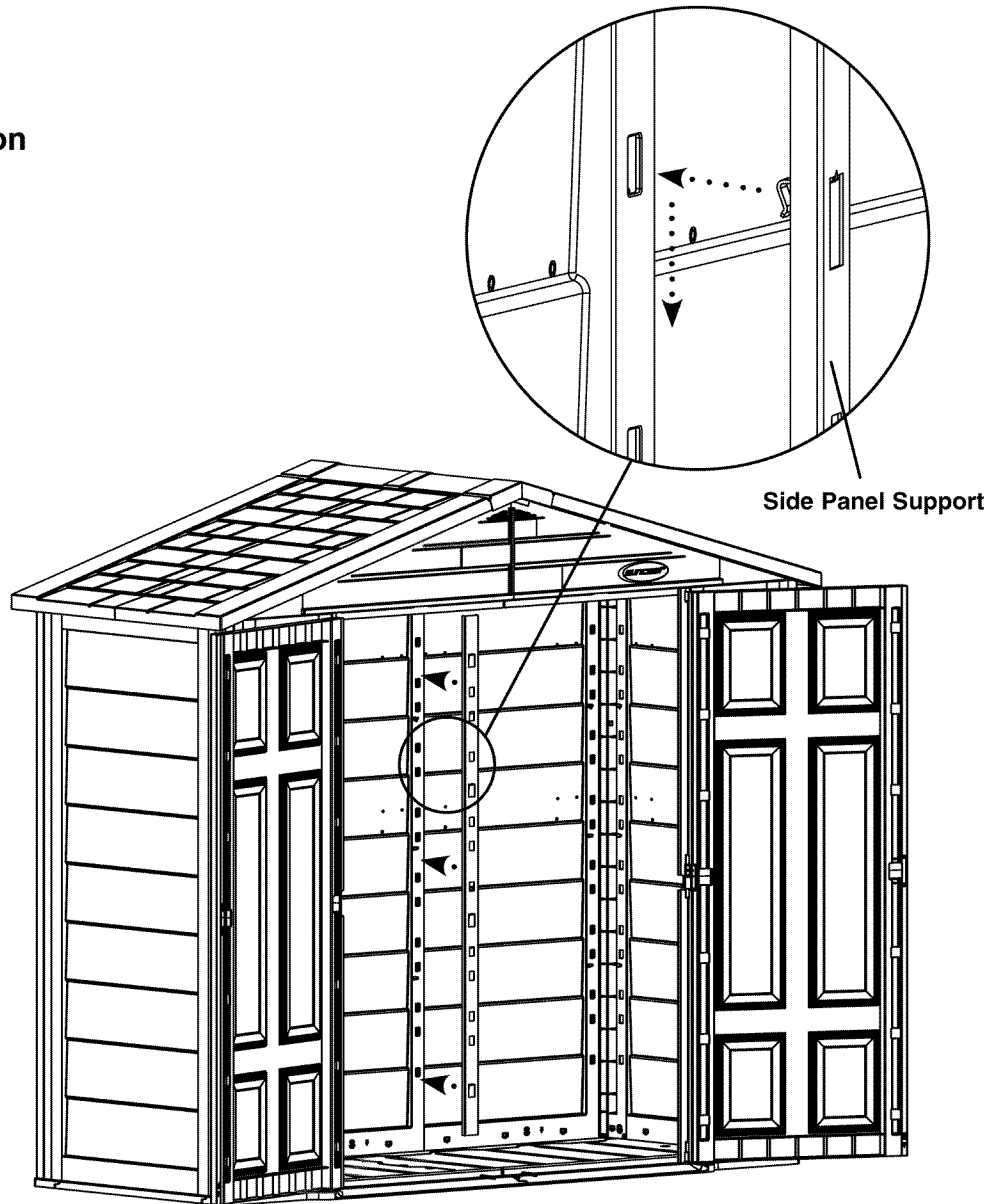

## Warranty

Suncast® Corporation, 701 North Kirk Road, Batavia, Illinois 60510 (Manufacturer) warrants to the original purchaser only that the enclosed product is free from material and workmanship defects under normal, household use at time of purchase. Defective product or part must be returned, freight prepaid, to the Manufacturer's address (Attention: Parts Department) along with proof of purchase. Upon receipt of the aforesaid, the defective product or part will be repaired or replaced at the option of the Manufacturer without charge to the original purchaser and returned to the customer freight collect.

This limited warranty does not apply to damage resulting from accident, neglect, misuse, commercial use, alteration, operation not in accordance with instruction or repairs made or attempted by unauthorized persons.

This limited warranty applies only to the product enclosed and does not apply to accessory parts.

THE MANUFACTURER'S LIABILITY HEREUNDER IS LIMITED SOLELY TO THE REPAIR OR REPLACEMENT OF THE DEFECTIVE PRODUCT OR PART AND THE MANUFACTURER SHALL IN NO EVENT BE LIABLE FOR ANY INCIDENTAL OR CONSEQUENTIAL DAMAGES WHICH MAY RESULT FROM ANY DEFECT IN MATERIAL OR WORKMANSHIP OR FROM THE BREACH OF ANY EXPRESS OR IMPLIED WARRANTY.

Some states do not allow the exclusion or limitation of incidental or consequential damages, or a limitation of how long an implied warranty lasts, so the above limitations may not apply to you. This warranty gives you specific legal rights, and you may have other rights which may vary from state to state.

## Factory Repairs

Repair service and assembly assistance are available direct from the factory, not from the place of purchase. If this product requires repair, please call or write us. Warranty repair parts are sent out free of charge. If the product is out of warranty, we will inform you of the charges prior to sending out the parts. VISA and MasterCard are accepted on phone orders. For Assembly or Replacement Parts Information:

Replacement Parts  
Suncast Corporation  
701 North Kirk Road  
Batavia, IL 60510

Outside Illinois, but within North America  
800-846-2345  
24 hour service / 7 days a week

Within Illinois, or outside North America  
630-879-2050  
visit: [www.suncast.com](http://www.suncast.com)  
email: [parts@suncast.com](mailto:parts@suncast.com)

**PATENTS**  
Patents pending.

## Securing Your Shed

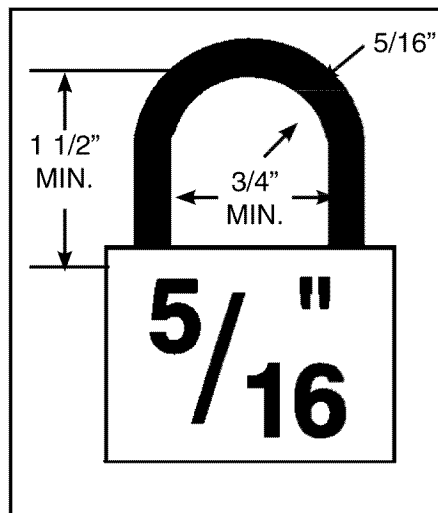

To properly lock your shed using the Padlock Assembly feature, 5/16" padlock is recommended.

Quality Control Number