

TT-CL009

 **TaoTronics**
www.taotronics.com

NORTH AMERICA

E-mail : support@taotronics.com(US)

support.ca@taotronics.com(CA)

Tel : 1-888-456-8468 (Monday-Friday: 9:00 - 17:00 PST)

US Distributor: SUNVALLEYTEK INTERNATIONAL INC.

Address:46724 Lakeview Blvd, Fremont, CA 94538

EUROPE

E-mail:

support.uk@taotronics.com(UK)

support.de@taotronics.com(DE)

support.fr@taotronics.com(FR)

support.es@taotronics.com(ES)

support.it@taotronics.com(IT)

EU Importer: ZBT International Trading GmbH

Address:Halstenbeker Weg 98C, 25462 Rellingen, Deutschland

ASIA PACIFIC

E-mail: support.jp@taotronics.com(JP)

Tel: 03-5542-0238 (10-18時/土日祝除く)

JP Importer: 株式会社ニアバイダイレクトジャパン

Address:東京都中央区入船2-9-5 HKビル2F

MANUFACTURER

Manufacturer: Shenzhen NearbyExpress Technology Development Co.,Ltd.

Address: 333 Bulong Road, Shenzhen, China, 518129

Learn more about the EU Declaration of Conformity:

<https://www.taotronics.com/downloads-TT-CL009-CE-Cert.html>

 **TaoTronics**
www.taotronics.com

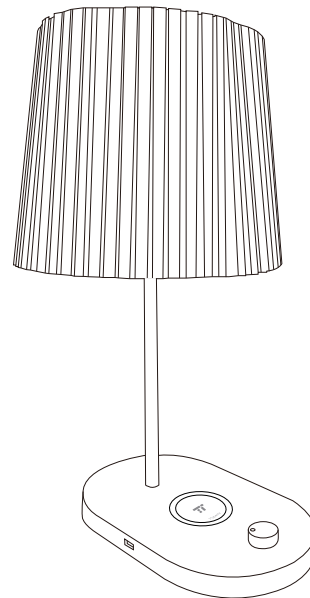

LED BEDSIDE LAMP
User Guide

CONTENTS

English	01/05
Deutsch	06/10
Français	11/15
Español	16/20
Italiano	21/25
日本語	26/30

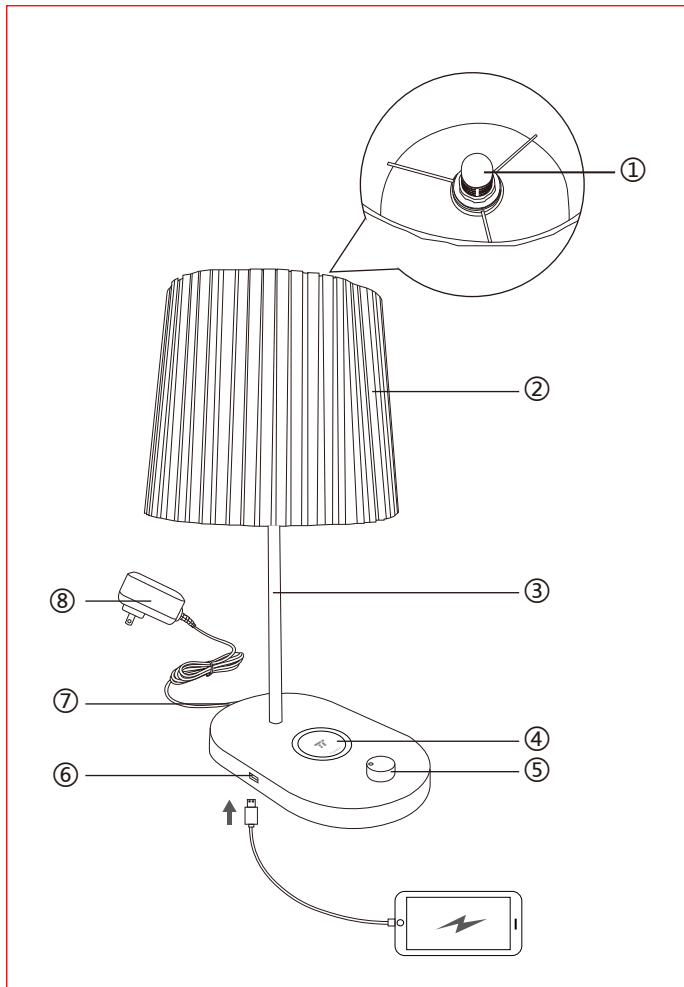

EN

Product Diagram

1. LED Light Bulb
2. Lamp Shade
3. Lamp Arm
4. Wireless Charging Pad
5. Power Button / Brightness Knob
6. USB Port
7. Power Port
8. Power Adapter

DE

Produktabbildung

1. LED-Leuchtmittel
2. Lampenschirm
3. Lampenarm
4. Induktives Ladepad
5. Powerknopf / Helligkeitsdrehknopf
6. USB-Anschluss
7. Stromanschluss
8. Stromstecker

FR

Description du Produit

1. Ampoule à LED
2. Abat-jour
3. Tige de Lampe
4. Zone de Chargement Sans Fil
5. Bouton d'Alimentation / Bouton de Luminosité
6. Port USB
7. Port d'Alimentation
8. Adaptateur Secteur

ES

Diagrama del Producto

1. Bombilla LED
2. Pantalla de Lámpara
3. Brazo de Lámpara
4. Base de Carga Inalámbrica
5. Botón de Encendido / Perilla de Brillo
6. Puerto USB
7. Puerto de alimentación
8. Adaptador de Corriente

IT

Schema del Prodotto

1. Paralume
2. Lampadina LED
3. Braccio della Lampada
4. Base di Ricarica Wireless
5. Pulsante di Accensione / Manopola Luminosità
6. Porta USB
7. Porta di Alimentazione
8. Adattatore di Corrente

JP

製品図

1. ランプシェード
2. LEDライト電球
3. ランプアーム
4. ワイヤレス充電パッド
5. 電源ボタン / 明るさ調整ダイヤル
6. USBポート
7. 電源ポート
8. 電源アダプター

Assembling the Lamp



1. Thread the wire through the hole on the base
2. Hold tight the lamp pole with one hand, lift the base upside down



3. Align and mount the washer
4. Washer is well mounted with all the corners aligned



5. Mount the screw nut onto the washer
6. Hold tight the lamp pole while tightening the nut with the included wrench



7. Connect the wires, make sure the terminals perfectly fit in place
8. Cover up the hole and rotate the cover clockwise to lock in place

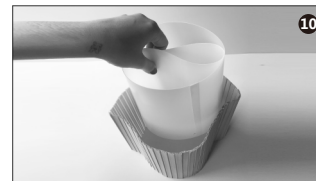

9. Remove the double-sided tape protectors on the inner lamp shade, patch the 3 pieces together in sequences as labelled
10. Squeeze the inner lamp shade into the outer shade, stretch them to form a circular shape

Note: Do not wash the outer shade.

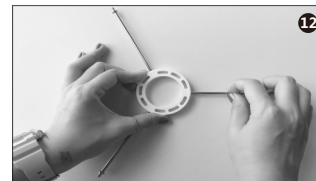
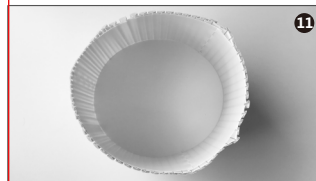

11. Move the outer shade around to align with the 3 holes with that of the inner shade for the support frame
12. Insert the separate bar into the frame support ring to set up the shade support frame

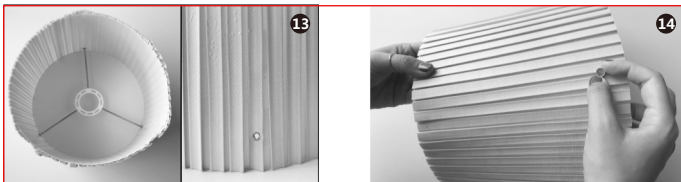

13. Align the 3 bars of the frame with the holes on the shades

14. Fix the frames in place with the nuts

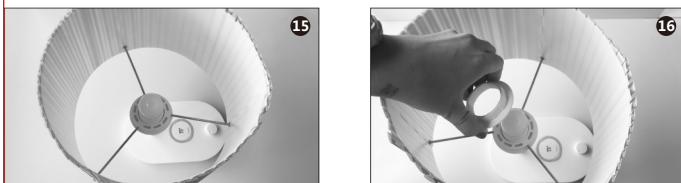

15. Place the shade on top of the lamp pole

16. Lock the shade in place with the plastic ring

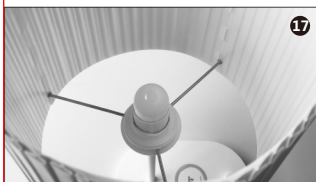

17. Lamp ready for use

Specifications

Model	TT-CL009
Light Source	LED
CRI	>80
Operating Voltage	DC 10V / 3A
Power (Only for the Light)	11W
USB Output	DC 5V / 1A
Wireless Charger Output	10W Max
Lumens	350lm
Color Temperature	2600K - 3000K
Operating Temperature	-10°C to 45°C / -14°F to 113°F

How to Use

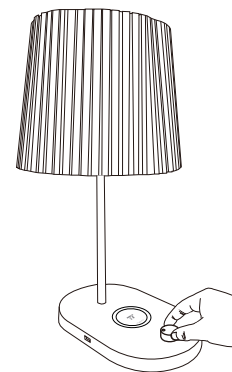

Power On / Off

- Connect the adapter to a wall outlet, the lamp enters standby mode.
- Tap the Power Button to turn on / off the lamp.
- Press and hold the Power Button to turn on the lamp on the lowest brightness setting.

Brightness Control

Rotate the Brightness Knob clockwise to increase the brightness and counterclockwise to dim the light.

Memory Function

The lamp will resume the brightness setting of the time when it was last turned off.

Note: Set the lamp to low brightness level when you turn it off to prevent glare.

USB Port

Charge your smartphone, tablet, e-reader or any USB devices through the 5V / 1A USB port.

Wireless Charging Pad

- Place your phone with Qi-BPP compatibility on the wireless charging station to automatically start charging.
- The charger supports 7.5W wireless charging for newest iPhone X / 8 Plus / 8 in iOS 11.2 or above and 10W fast charging to selected Samsung Galaxy, Google Nexus, or Microsoft Lumia phones.

Note:

If charging does not occur, adjust the phone so its receiver can be detected. Please note that different model phones have their receivers in different positions.

DE

Zusammenbau der Lampe



1. Führen Sie das Kabel durch das Loch in der Basis
2. Halten Sie die Lampenstange mit einer Hand fest und drehen Sie die Basis verkehrtherum



3. Richten Sie die Unterlegscheibe aus und montieren Sie sie
4. Die Unterlegscheibe ist mit der Aussparung richtig ausgerichtet angebracht



5. Schrauben Sie die Mutter auf die Unterlegscheibe
6. Halten Sie die Lampenstange fest, während Sie die Mutter mithilfe des mitgelieferten Schraubenschlüssels festziehen

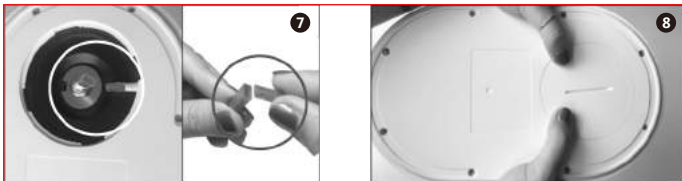

7. Verbinden Sie die Kabel, stellen Sie sicher, dass die Anschlüsse perfekt an Ort und Stelle passen

8. Verdecken Sie die Öffnung wieder und drehen Sie die Abdeckung im Uhrzeigersinn, um sie zu verschließen

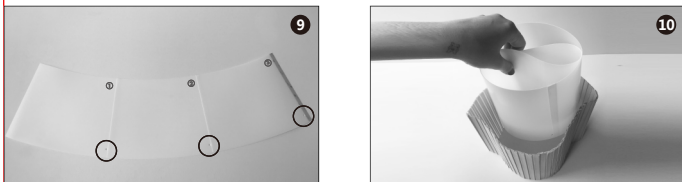

9. Entfernen Sie die doppelseitigen Klebebandschützer auf dem inneren Lampenschirm und kleben Sie die 3 Teile in der angegebenen Reihenfolge zusammen

10. Drücken Sie den inneren Lampenschirm in den äußeren Lampenschirm und strecken Sie ihn, um eine kreisförmigen Form zu bilden

Hinweis: Waschen Sie den Außenschirm nicht.

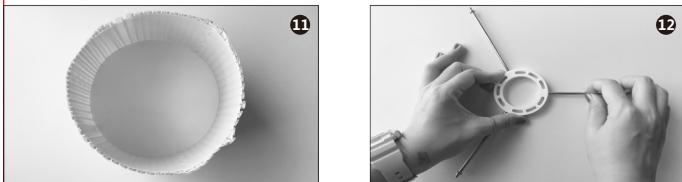

11. Verschieben Sie den Außenschirm, um die 3 Löcher mit dem Innenschirm des Stützrahmens auszurichten

12. Setzen Sie die separate Stange in den Rahmenhalterungsring, um den Schattenhalterahmen einzurichten

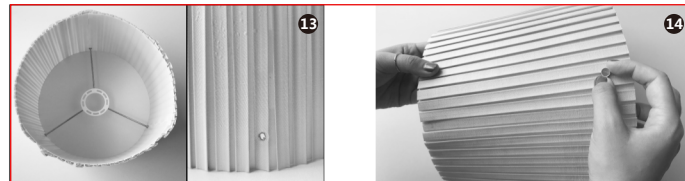

13. Richten Sie die 3 Stangen des Rahmens an den Löchern der Schirme aus.

14. Befestigen Sie die Rahmen mit den Muttern

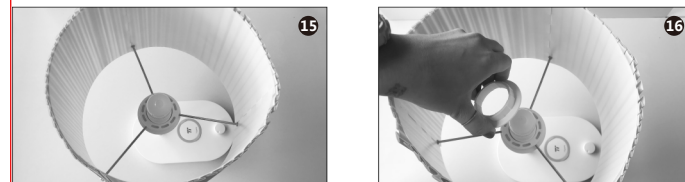

15. Platzieren Sie den Schirm oben auf dem Lampenstange

16. Schließen Sie den Schirm mit dem Plastikring ab

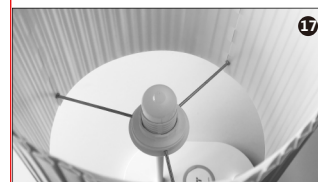

17. Die Lampe ist betriebsbereit

Spezifikationen

Modell	TT-CL009
Lichtquelle	LED
CRI	>80
Betriebsspannung	10V / 3A
Leistung (Nur das Licht)	11W
USB-Ausgang	DC 5V / 1A
Ausgangsleistung des kabellosen Ladegerätes	10W max
Lumen	350 lm
Farbtemperatur	2600K - 3000K
Betriebstemperatur	-10°C bis 45°C / -14°F bis 113°F

Anleitung

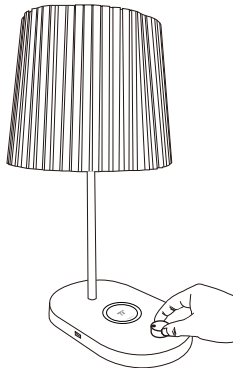

Ein- / Ausschalten

- Stecken Sie den Netzstecker in eine Steckdose. Die Lampe wechselt in den Standby-Modus.
- Tippen Sie den Powerknopf an, um die Lampe ein- / auszuschalten.
- Halten Sie den Powerknopf gedrückt, um die Lampe auf geringster Helligkeitseinstellung einzuschalten.

Helligkeitssteuerung

Drehen Sie den Helligkeitsdrehknopf im Uhrzeigersinn, um die Helligkeit zu erhöhen, und gegen den Uhrzeigersinn, um das Licht zu dimmen.

Speicherfunktion

Die Lampe nimmt die Helligkeitseinstellung wieder auf, die beim letzten Ausschalten aktiv war.

Anmerkung: Stellen Sie die Lampe auf eine niedrige Helligkeitsstufe, wenn Sie sie ausschalten, damit Sie nicht geblendet werden.

USB-Anschluss

Laden Sie Ihr Handy, Tablet, E-Reader oder andere USB-Geräte mit dem 5V/1A USB-Anschluss.

Kabellos aufladen

- Legen Sie Ihr Handy mit Qi-BPP-Kompatibilität auf die kabellose Ladestation, um es automatisch aufzuladen.
- Das Ladegerät unterstützt 7.5W kabelloses Laden für die neuesten iPhone X / 8 Plus / 8 mit dem aktuellen iOS 11.2 oder höher, und 10W Schnellladen für bestimmte Samsung Galaxy, Google Nexus und Microsoft Lumia.

Hinweis:

Wenn das Laden nicht automatisch beginnt, legen Sie Ihr Handy so hin, dass der Empfänger erkannt werden kann. Bitte beachten Sie, dass verschiedene Handymodelle ihren Empfänger an unterschiedlichen Positionen haben.

FR

Assemblage de la Lampe



1. Faites passer le câble par le trou du socle
2. Tenez fermement la tige de la lampe d'une main, tournez le socle à l'envers



3. Alignez et installez la rondelle
4. La rondelle est bien mise quand tous les coins sont alignés



5. Mettez l'écrou sur la rondelle
6. Tenez fermement la tige de la lampe tout en serrant l'écrou avec la clé incluse



7. Connectez les câbles, assurez-vous que les terminaux sont parfaitement en place
8. Couvrez le trou et faites tourner le cache dans le sens horaire pour le verrouiller en place

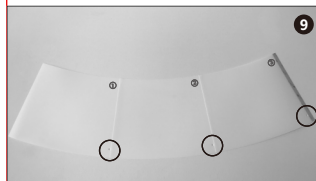

9. Enlevez les protecteurs de ruban adhésif double-face sur l'abat-jour intérieur de lampe, collez les 3 morceaux ensemble dans des séquences comme étiquetées
10. Pressez l'abat-jour intérieur dans l'abat-jour extérieure, étirez-les pour former une forme circulaire

Remarque: Ne pas laver l'abat-jour extérieur.

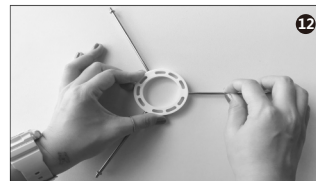
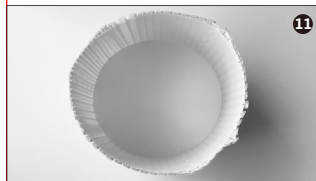

11. Déplacez l'abat-jour extérieur pour l'aligner avec celui de l'abat-jour intérieur pour le cadre de support
12. Insérez la barre séparée dans la bague du cadre de support pour installer le cadre de support d'abat-jour

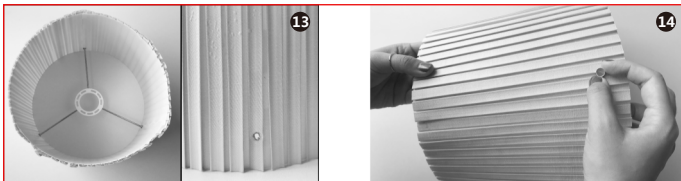

13. Alignez les 3 barres du cadre avec les trous de l'abat-jour

14. Fixez les cadres en place avec les écrous

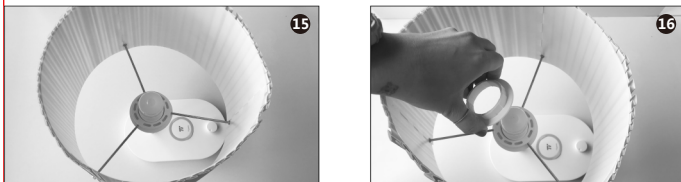

15. Placez l'abat-jour sur le dessus de la lampe

16. Verrouillez l'abat-jour en place avec l'anneau en plastique



17. La lampe est prête à utiliser

Spécifications

Modèle	TT-CL009
Source Lumineuse	LED
CRI	>80
Tension de Fonctionnement	10V / 3A
Puissance (Seulement pour la Lampe)	11W
Sortie USB	DC 5V / 1A
Sortie de Chargement Sans Fil	10W Max
Lumens	350lm
Température de Couleur	2600K - 3000K
Température de fonctionnement	-10 à 45°C

Mode d'Emploi

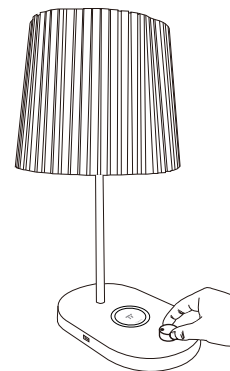

Marche / Arrêt

- Connectez l'adaptateur à une prise secteur, la lampe entre en mode veille.
- Touchez le Bouton d'Alimentation pour allumer / éteindre la lampe.
- Appuyez et maintenez le Bouton d'Alimentation pour allumer la lampe avec le réglage de luminosité le plus bas.

Réglage de Luminosité

Tournez le Bouton de Luminosité dans le sens horaire pour augmenter la luminosité et dans le sens antihoraire pour baisser la lumière.

Fonction Mémoire

La lampe rétablira le réglage de luminosité de la dernière fois où elle a été éteinte.

Nota: Réglez la lampe sur un niveau de luminosité faible lorsque vous l'éteignez pour éviter l'éblouissement.

Port USB

Chargez votre smartphone, tablette, liseuse électronique, ou tout autre périphérique USB via le port USB 5V / 1A.

Chargeur Sans-fil

- Placez votre téléphone compatible Qi-BPP sur la station de charge sans fil pour démarrer automatiquement le chargement.
- Le chargeur supporte la recharge sans fil de 7,5 W pour le dernier iPhone X / 8 Plus / 8 avec iOS 11.2 ou supérieur, et le chargement rapide de 10W pour Samsung Galaxy, Google Nexus ou Microsoft Lumia sélectionné.

Nota:

Si le chargement ne démarre pas, bougez le téléphone pour que son récepteur puisse être détecté. Veuillez noter que suivant le modèle de téléphone, les récepteurs sont dans différentes positions.

ES

Ensamblar la Lámpara



1. Inserte el cable a través del agujero en la base
2. Sostenga el poste de la lámpara con una mano, levante la base boca abajo



3. Alinee y coloque la arandela
4. La arandela estará bien montada cuando todas las esquinas estén alineadas



5. Atornille la tuerca a la arandela
6. Mantenga apretado el poste de la lámpara mientras apriete la tuerca con la llave incluida



7

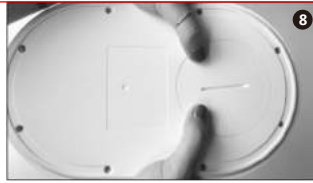

8

7. Conecte los cables, asegúrese de que los terminales encajen perfectamente en su lugar

8. Cubra el agujero y gire la tapa a la derecha para bloquear en su lugar

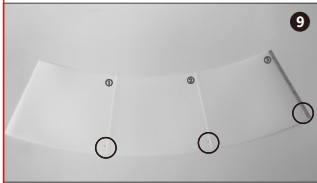

9

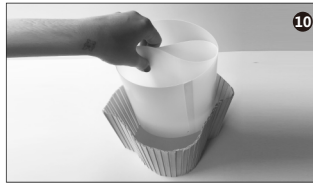

10

9. Retire los protectores de cinta de doble cara en la pantalla interna de la lámpara, coloque las 3 piezas juntas en orden de marcado

10. Apriete la pantalla interna de la lámpara para que lo ponga dentro de la pantalla externa, estírela para restaurar la apariencia circular

Nota: No lave la pantalla exterior.

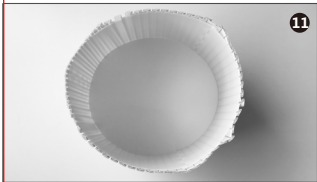

11

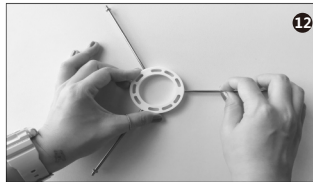

12

11. Mueva la pantalla externa para alinear los 3 orificios con los de la interna para el marco de soporte

12. Inserte la barra separada en el anillo de soporte del marco para configurar el marco de soporte de la pantalla

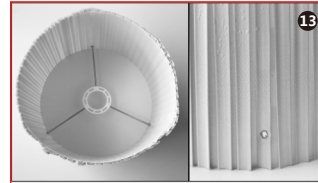

13



14

13. Alinee las 3 barras del marco con los agujeros en las pantallas

14. Fije el marco en su lugar con las tuercas

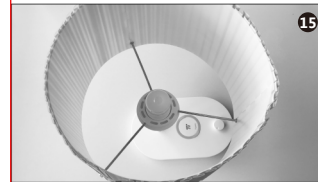

15



16

15. Coloque la pantalla en la parte superior de la poste de la lámpara

16. Ajuste el marco en su lugar con el anillo de plástico



17

17. La lámpara está lista para usar

Especificaciones

Modelo	TT-CL009
Fuente de luz	LED
CRI	> 80
Voltaje de Operación	10V/3A
Energía (Solo para la luz)	11W
Salida USB	DC 5V/1A
Salida de Cargador Inalámbrico	10W Max
Lúmenes	350 lm
Temperatura del Color	2600K - 3000K
Temperatura de Funcionamiento	-10°C a 45°C / -14°F a 113°F

Cómo usarla



Encendido / Apagado

- Conecte el adaptador a una toma de corriente de pared, la lámpara entrará en modo de espera.
- Toque el Botón de Encendido para encender / apagar la lámpara.
- Presione y mantenga presionado el Botón de Encendido para encender la lámpara con la configuración de brillo más baja.

Control de Brillo

Gire la Perilla de Brillo a la derecha para aumentar el brillo y a la izquierda para reducirlo.

Función de Memoria

La lámpara se reanuda a la configuración de brillo que fue usada la última vez.

Nota: Ajuste la lámpara a bajo nivel de brillo cuando la apague para evitar el deslumbramiento.

Puerto USB

Cargue su smartphone, tableta, e-reader o cualquier dispositivo USB a través del puerto USB 5V / 1A .

Cargador Inalámbrico

- Coloque su teléfono con compatibilidad Qi-BPP en la estación de carga inalámbrica para comenzar la carga automáticamente.
- El cargador soporta la carga inalámbrica de 7,5W para el nuevo iPhone X / 8 Plus / 8 con el sistema iOS 11.2 o más superior y la de 10 W para la carga rápida a dispositivos seleccionados de Samsung Galaxy, Google Nexus, o los Lumia de Microsoft.

Nota:

Si no se inicia la carga, ajuste el teléfono para que se pueda detectar su receptor. Tenga en cuenta que diferentes modelos de teléfono tienen sus receptores en diferentes lugares.

Assemblaggio della Lampada



1. Infilare il cavo attraverso il foro nella base
2. Stringere il sostegno per lampada con una mano, capovolgendo la base



3. Allineare e montare la rondella
4. La rondella è montata correttamente quando tutti gli angoli sono allineati



5. Montare il dado sopra la rondella
6. Stringere il sostegno per lampada e stringere il dado con la chiave inclusa



7. Collegare i cavi, assicurarsi che i terminali si adattano perfettamente al posto
8. Coprire il foro e ruotare il coperchio in senso orario per bloccare

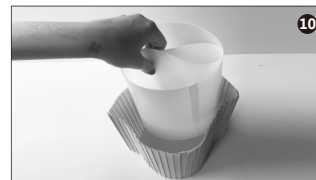

9. Rimuovere le protezioni del nastro biadesivo sul paralume interno, rappezzare i 3 pezzi insieme in sequenze come etichettato
10. Spremere il paralume interno nel paralume esterno, allungarli per formare una forma circolare

Nota: non lavare il paralume esterno.

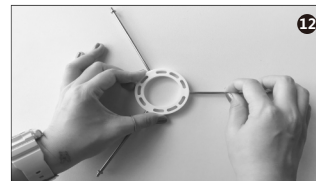
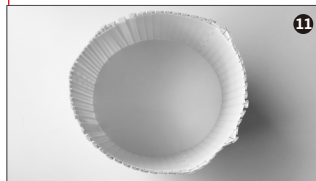

11. Spostare il paralume esterno per allinearli con i 3 fori con quello del paralume interno per la struttura di supporto
12. Inserire la barra separata nell'anello di supporto della struttura per impostare la struttura di supporto del paralume

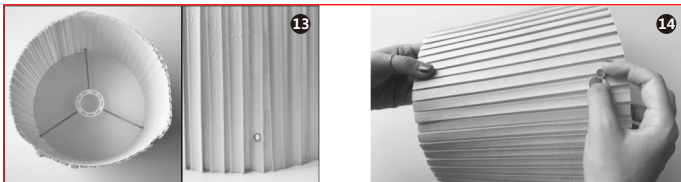

13. Allineare le 3 barre della struttura con i fori sulle paralumi

14. Fissare la struttura in posizione con i dadi

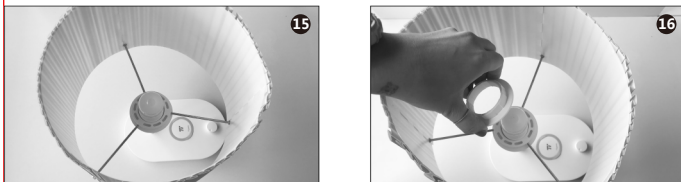

15. Posizionare il paralume sopra il Sostegno della lampada

16. Bloccare il paralume in posizione con l'anello di plastica



17. Lampada pronta per l'uso

Specifiche

Modello	TT-CL009
Fonte Luminosa	LED
IRC	>80
Tensione di Esercizio	10V / 3A
Alimentazione (Solo per la Luce)	11W
Uscita USB	5V DC / 1A
Uscita Caricabatterie Wireless	10W Max
Lumen	350lm
Temperatura Colore	2600K - 3000K
Temperatura di Esercizio	Da -10°C a 45°C / Da -14°F a 113°F

Modalità di Utilizzo

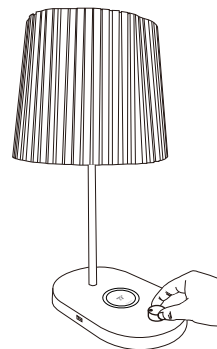

Accensione / Spegnimento

- Collegare l'adattatore ad una presa di corrente. La lampada entrerà in modalità stand-by.
- Premere il Pulsante di Accensione per accendere / spegnere la lampada.
- Premere e tenere premuto il Pulsante di Accensione per accendere la lampada con le impostazioni di luminosità più basse.

Controllo della Luminosità

Ruotare la Manopola Luminosità in senso orario per aumentare la luminosità e in senso antiorario per attenuare la luce.

Funzione Memoria

La lampada si riaccenderà con le impostazioni di luminosità memorizzate prima dell'ultimo spegnimento.

Nota: Prima dello spegnimento, impostare la lampada su un livello di luminosità basso per evitare bagliori indesiderati.

Porta USB

Per ricaricare smartphone, tablet, e-reader o qualsiasi altro dispositivo USB attraverso la porta USB da 5V/1A. .

Caricabatterie Wireless

- Appoggiare un telefono compatibile con lo standard Qi-BPP sulla base di ricarica wireless per iniziare automaticamente la ricarica.
- Supporta wireless charging fino a 7.5W per l'iPhone X / 8 Plus / 8 con iOS 11.2 o superiore e fast charging fino a 10W per i dispositivi Samsung Galaxy, Google Nexus e Microsoft Lumia compatibili.

Nota:

Se la ricarica non parte, regolare il telefono in modo che il suo ricevitore possa essere rilevato. Si prega di notare che non tutti i telefoni hanno il ricevitore nella stessa posizione.

JP

ランプの組み立て手順



1. ベースの穴にワイヤーを通してください
2. ランプボールを片手でしっかり固定し、ベースを逆さまにして下さい



3. ワッシャーを設置して下さい
4. ワッシャーの位置が全て正確に設置されていることを確認して下さい



5. スクリューナットをワッシャーの上に設置して下さい
6. ランプボールをしっかり持ち付属のレンチでナットを締めて下さい

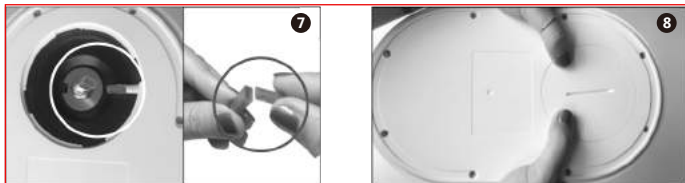

7. ワイヤを繋げて下さい。端子が完全に固定されていることを確認して下さい
8. 穴にカバーをかぶせ、時計回りに回して固定して下さい

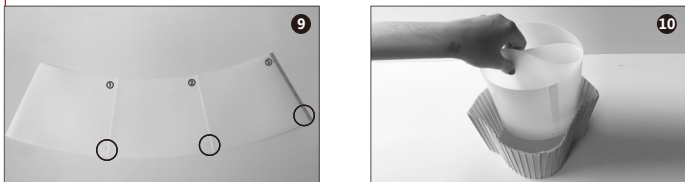

9. 内側のランプシェードの両面テーププロテクターを取り外し、ラベルが付いた順に3つの部分を貼り付けて下さい
10. 内側のシェードを外側のシェードに押し込み、伸ばして円形にします
ご注意: グレアを防ぐために、ランプを消灯する前に、明るさを低輝度レベルに設定してください

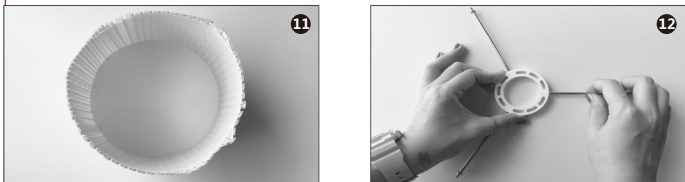

11. 外側のシェードを動かして、3つの穴とサポートフレームの内側のシェードの穴に合わせて下さい
12. 別のバーをフレームサポートリングに差し込んでシェードサポートフレームをセットアップしてください

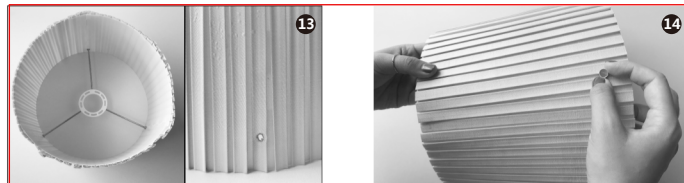

13. シェードの穴とシェードフレーム3つのポールを合わせて下さい
14. ナットでフレームを固定して下さい

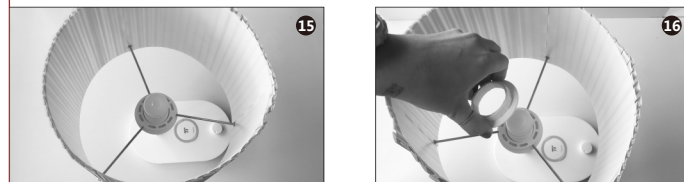

15. ランプボールの上にシェードを設置して下さい
16. プラスチックリングでシェードを固定して下さい

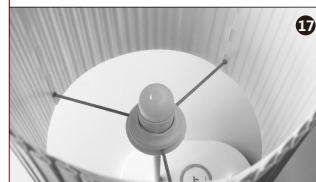

17. 準備完了

仕様

モデル	TF-CL009
ライト源	LED
CRI	>80
動作電圧	10V / 3A
電源 (ライトのみ)	11W
USB 出力	DC 5V / 1A
ワイヤレス充電出力	最大10W
ルーメン	350lm
色温度	2600K - 3000K
動作温度	-10°C ~ 45°C

使い方

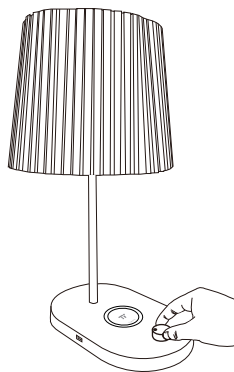

電源オン / オフ

- ・コンセントへアダプターを接続すると、ランプはスタンバイモードになります。
- ・電源ボタンをタッチすると電源のオン/オフが出来ます。
- ・電源ボタンを長押しすると、一番低い明るさのレベルに設定出来ます。

NOTE: This equipment has been tested and found to comply with the limits for a Class B digital device, pursuant to part 15 of the FCC Rules. These limits are designed to provide reasonable protection against harmful interference in a residential installation. This equipment generates uses and can radiate radio frequency energy and, if not installed and used in accordance with the instructions, may cause harmful interference to radio communications.

However, there is no guarantee that interference will not occur in a particular installation. If this equipment does cause harmful interference to radio or television reception, which can be determined by turning the equipment off and on, the user is encouraged to try to correct the interference by one or more of the following measures:

- Reorient or relocate the receiving antenna.
- Increase the separation between the equipment and receiver.
- Connect the equipment into an outlet on a circuit different from that to which the receiver is connected.
- Consult the dealer or an experienced radio/TV technician for help

Changes or modifications not expressly approved by the party responsible for compliance could void the user's authority to operate the equipment.

This device complies with Part 15 of the FCC Rules. Operation is subject to the following two conditions:

- (1) this device may not cause harmful interference, and (2) this device must accept any interference received, including interference that may cause undesired operation.

RF Exposure Warning Statements:

This equipment complies with FCC radiation exposure limits set forth for an uncontrolled environment. This equipment shall be installed and operated with minimum distance 20cm between the radiator & body.