

DJI Master Wheels

V1.0 2018.05

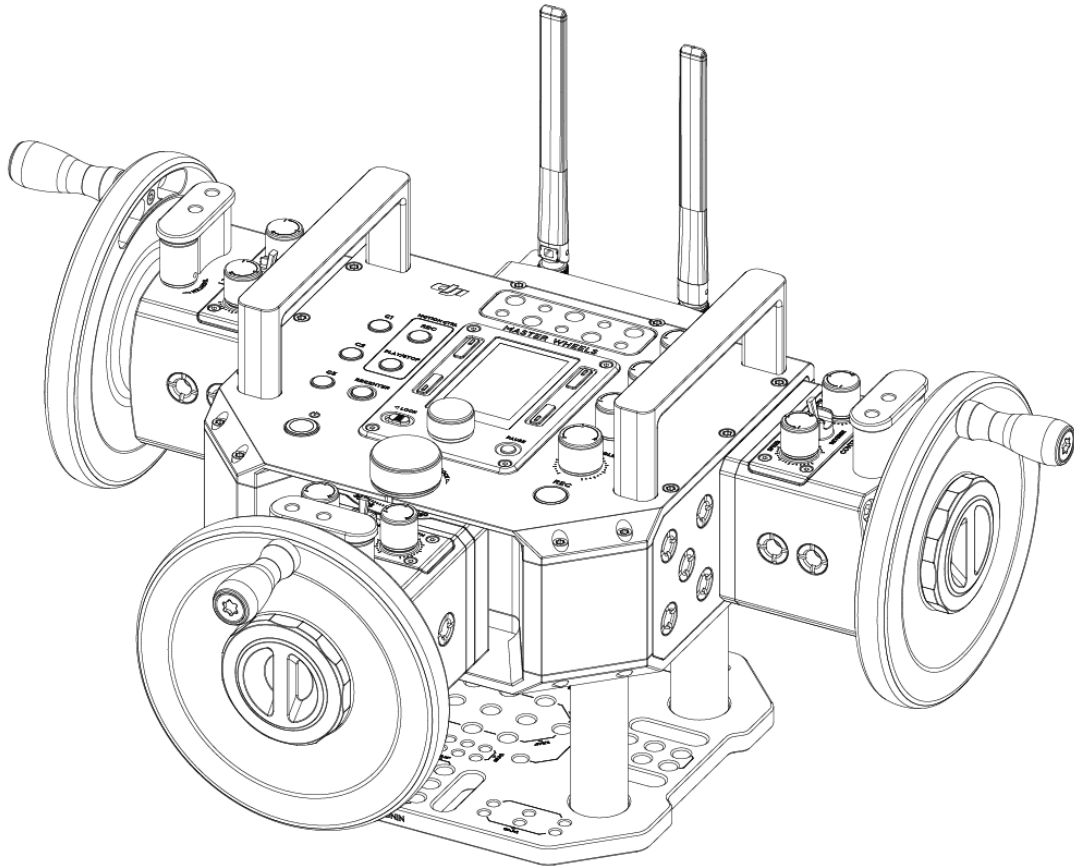

Introduction

The Master Wheels controller is an advanced professional wheel controller system that employs high-precision sensors, advanced control algorithms, and state-of-the-art product design to deliver precise and butter-smooth remote camera movement control. With the included receiver, Master Wheels are compatible with the Ronin 2 and Ronin-S, and third-party gimbals through an S-BUS connection.

Master Wheels feature a modular design, so wheels and control modules can be detached from the base. The wheel and control modules can be operated completely separated from the base and connected via cables after being detached, giving users more freedom when shooting in tight spaces. Users can manually adjust the angle between two control modules for a more ergonomic fit. The radio transmission module can be quickly detached and placed in an open area to obtain a stronger signal.

Each wheel control module is equipped with a three-stop toggle switch to control gimbal direction and dials to control speed, smoothness, and damping. Also, various buttons and menus on main control console and three custom buttons allow you to monitor equipment status and adjust settings quickly.

Master Wheels' dual-frequency 2.4 GHz and 5.8 GHz wireless transmission system supports a max operation range of 3 km. Wired connection is also supported, keeping latency as low as 10 milliseconds.

The main control console contains multiple 1/4-20 and 3/8-16 taps for mounting monitors, video transmission systems, and more. Users can also charge monitors or wireless transmitters via the CAN BUS port. Master Wheels also come with a Mitchell mount that is attachable to the base plate for connecting to tripods, cars, and more, allowing users to shoot any scene they can imagine.

Motion Control lets cinematographers record specific movements and repeat them when needed.

Master Wheels use TB50 batteries, offering up to 18 hours of operating time, and their self-heating functionality ensures equipment works normally at temperatures as low as -20°.

Components

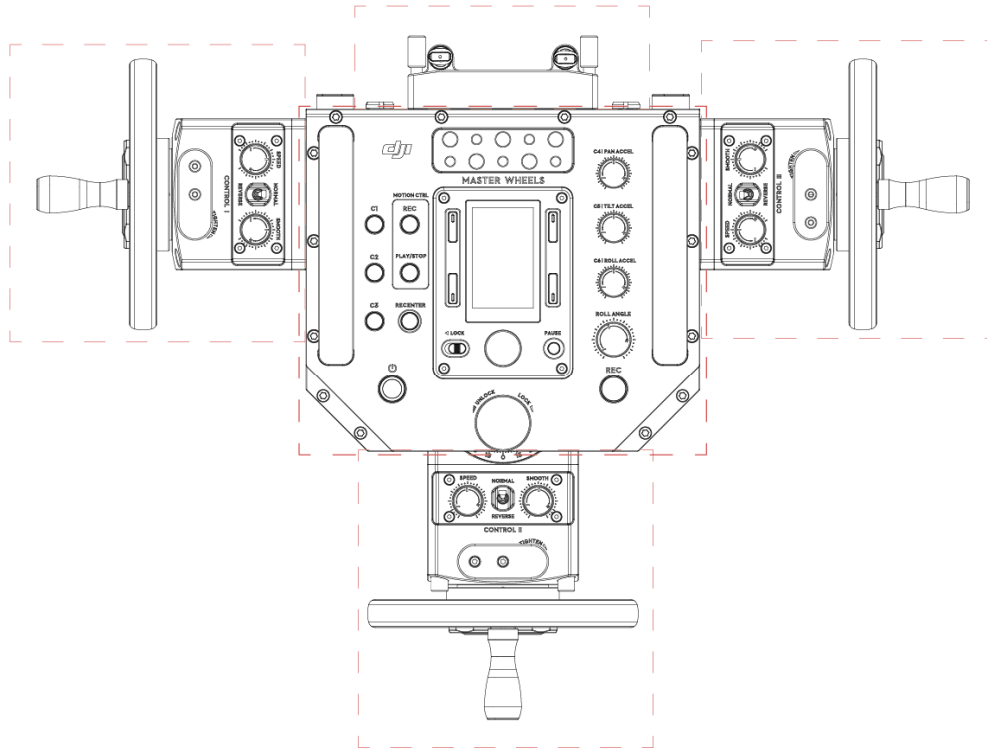

1. Wheel and Control Module I

The wheel and control module can be operated completely separated from the base and connected via cables after being detached, giving users more freedom when shooting in tight spaces.

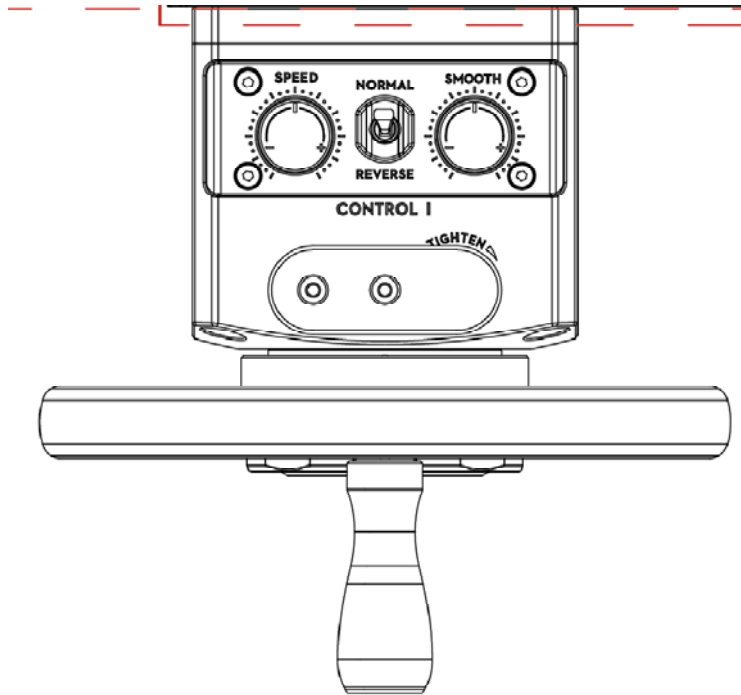

- a. Wheel: Rotate the wheel to control the gimbal axis movements.
 - b. Damping Adjustment Knob: Adjust the damping of the wheel.
 - c. Speed Adjustment Knob: Adjust the axis speed by turning the knob.
 - d. Direction Adjustment Knob: Reverse the axis movements' direction.
 - e. Smoothing Adjustment Knob: Adjust the Smoothing for gimbal axis.
2. Wheel and Control Module II
The same as Wheel and Control Module I.
 3. Wheel and Control Module III
The same as Wheel and Control Module I.
 4. Radio Transmission Module
The detachable radio transmission module can be placed in an open area to obtain a stronger signal.
 5. Main Control Base

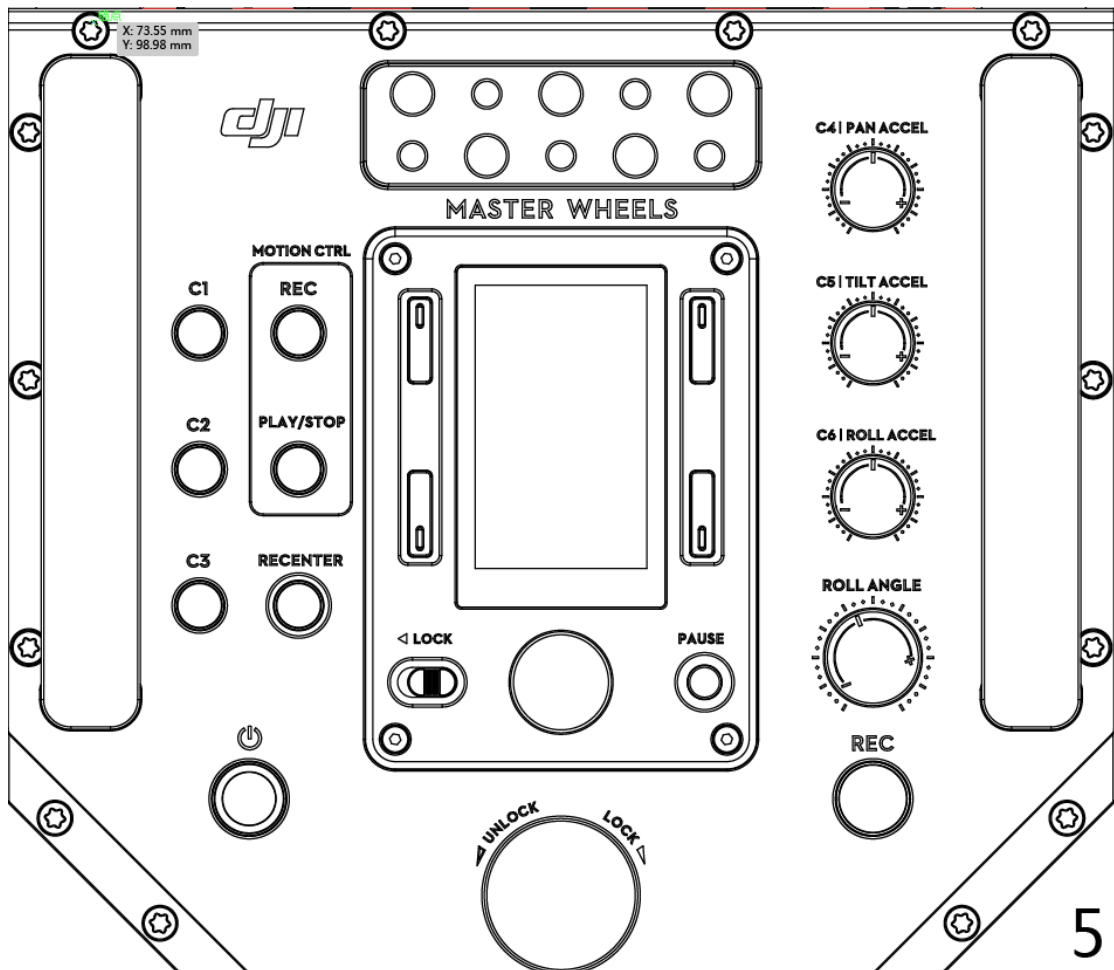

- a. 1/4"-20 and 3/8"-16 Mounting Hole
- b. Handle
- c. C1 Button: Customize the function through the on-board panel.
- d. C2 Button: Customize the function through the on-board panel.
- e. C3 Button: Customize the function through the on-board panel.
- f. Power Button: Press and hold to turn on/off the Master Wheels.
- g. Motion Control: Record the gimbal movements by press the REC button, repeat the recorded gimbal movements by pressing the PLAY button.
- h. Recenter Button: Press once to recenter the gimbal.
- i. On-board Panel:
 - Mounting Mode Button: Press to select a mounting mode for the gimbal.
 - Back Button: Press once to go back to the previous menu.
 - Toggle Button: Press once to toggle between the submenus.
 - Follow Mode Button: Press to select a Follow mode for the gimbal.
 - Lock Button: Toggle to lock the Panel during usage to avoid unexpected operation.
 - Jog Wheel/OK Button: Rotate to select options, and press once to confirm an option.
 - Pause Button: Press once to power off the motor without powering on the gimbal.
- j. C4 Pan Axis Acceleration Knob: Turn to adjust the acceleration for Pan Axis directly.
- k. C5 Tilt Axis Acceleration Knob: Turn to adjust the acceleration for Tilt Axis directly.
- l. C6 Roll Axis Acceleration Knob: Turn to adjust the acceleration for Roll Axis directly.

- m. Roll Axis Angle Adjustment Knob: Turn to adjust the roll axis angle.
- n. Record Button: Press to control camera start/stop recording after connecting to Shutter Control port on the Ronin 2's Power Hub.
- o. Angle Adjustment Knob: Toggle the knob to the unlocked position and adjust to the desired angle for Wheel and Control Module II, toggle to the locked position after complete.
- p. Main Control Base Ports

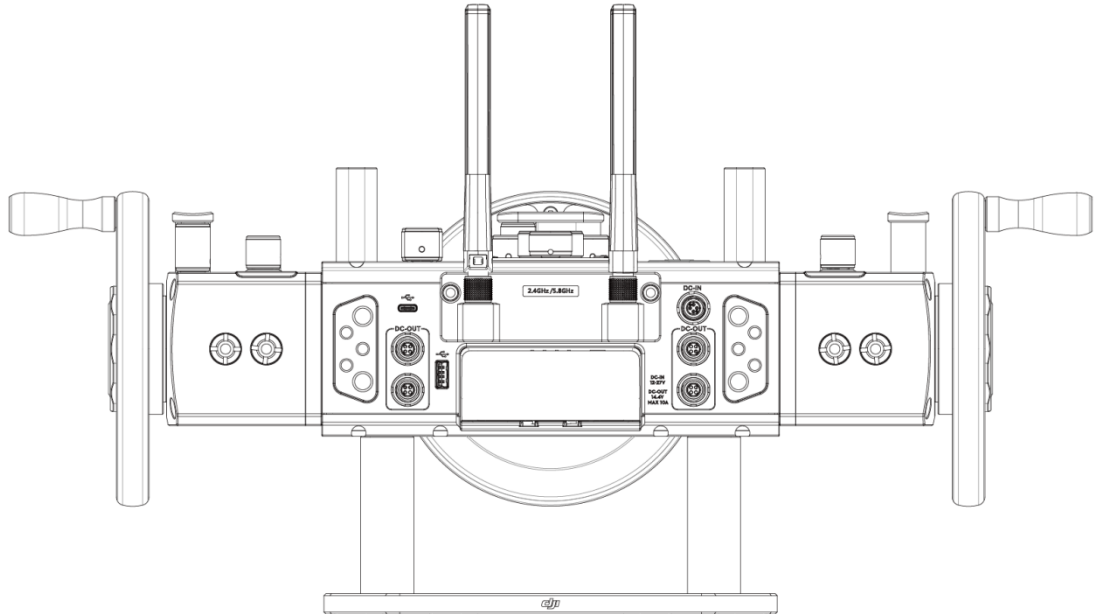

1. USB-C Port: For firmware updating.
 2. DC-OUT Port: 14.4V and the max current is 8A.
 3. DC-IN Port: 12-27V, power the connected device through this port.
 4. PogoPin: For connecting to the radio transmission module.
 5. CAN Port.
- q. Mounting Holes
1/4"-20 or 3/8"-16 mounting holes.

Installation

Mounting the Radio Transmission Module

Attach the radio transmission module by connecting to the pogo pin and then tighten the screws. Connect the radio transmission module to one of the DC-OUT port on the Master Wheel using the provided cable if you need to place the transmission module on the other position.

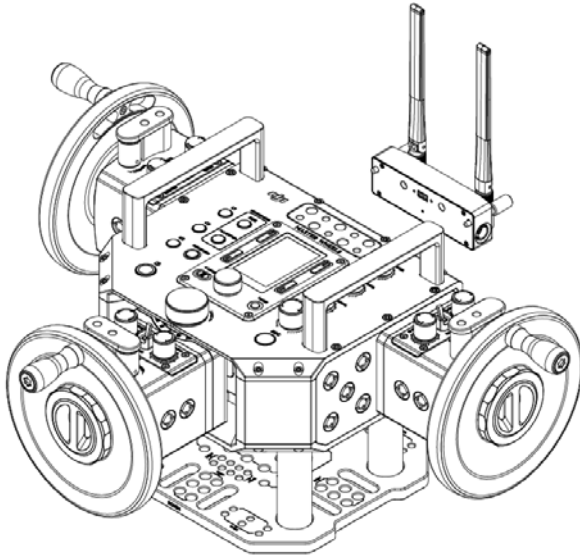

Adjust Angle for Wheel and Control Module II

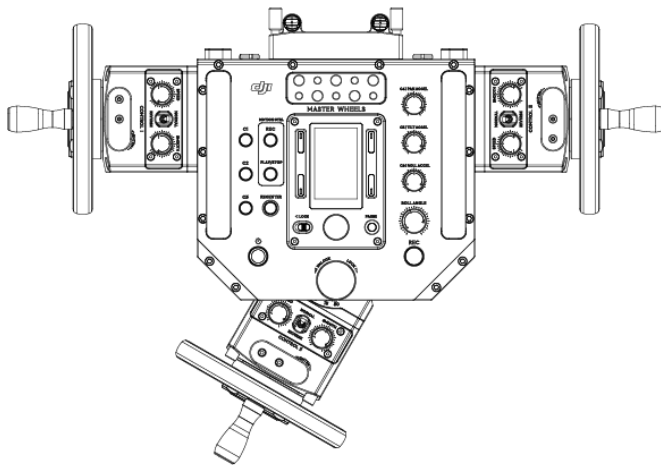

Mounting the Intelligent Battery

Insert the Intelligent Battery as shown. Press the lock button on the bottom of the base when remove the battery.

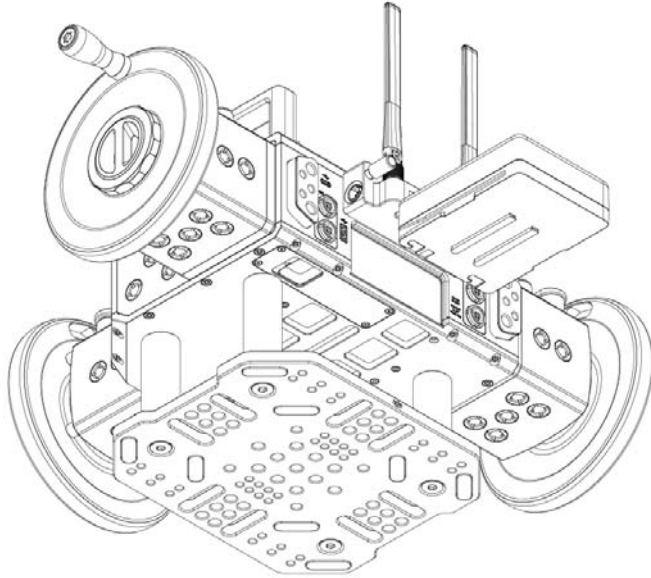

Mounting the Wheel and Control Modules

The Wheel and Control Modules are mounted on the base by default. If you need to remove them, detach the wheel firstly, and then loosen the screws to remove the control modules. Connect the wheel and control module to one of the DC-OUT port on the Master Wheel using the provided cable.

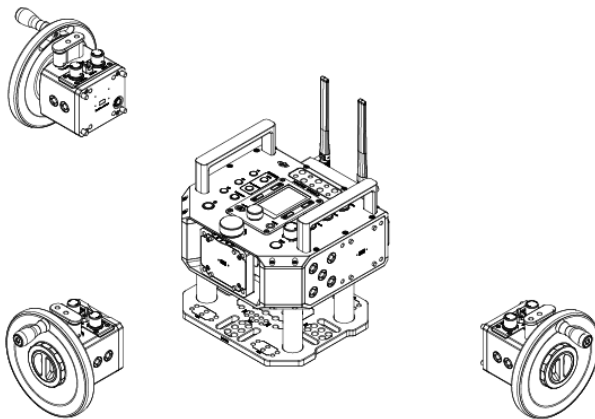











Mounting the Main Control Base to Other Platforms

Remove the bottom base and mount the main control base to other platform such as tripod through a Mitchell Mount.

Settings

These settings are based on using the Master Wheels with Ronin 2.

Main UI settings

1. GPS Signal Strength
¹²: Shows the current GPS signal strength.
2. Mounting Modes
 : Handheld mode.
 : Car Mount mode.
 : Aerial mode.
 : Tripod mode.
3. Follow Mode
 : Free mode.
 : Follow mode.
 : FPV mode.
 : Recenter mode.
4. Working Battery Number and Battery Level
² : Shows the number of batteries currently in use by Ronin 2 and the current battery level of Ronin 2.
5. Remote Controller Signal Strength
Displays the remote controller signal strength.
6. Master Wheels Battery Level
Displays the current battery level of the Master Wheels.
7. Max Speed
Displays the max speed of the pan, tilt and roll axis.
8. Smoothing
Displays the smoothing of the pan, tilt and roll axis.
9. Speed
Displays the real-time speed of the pan, tilt and roll axis.

Master Wheels Settings

Basic

The Deadband, Smoothing, and Endpoints settings for the pan, roll, and tilt axes can be independently adjusted. The default endpoint settings for pan axis are set to 180°, which means

there is no endpoint for the pan axis, allowing it to rotate 360°continuously.

More: Languages can be switched between English and Chinese. Displays the SN number and the firmware version of the Master Wheels.

Custom

Customized functions for the C1, C2 and C3 buttons, and assign pan, tilt and roll axis to one of the Wheel and Control module.

Gimbal settings

Motor

Basic: The Auto tune, Stiffness, Strength, Filter, and Control values for the tilt, roll, and pan axes can be set independently. Refer to the Ronin 2 user manual for details.

More: Set power-on position, fine tune the pan or tilt axis, and test the balance for three axes.

SmoothTrack

Settings for the pan, roll, and tilt axes can be set independently.

Monitor

Motor: Displays the power, angle, and temperature of the motors.

Log: Displays any abnormal status information of the gimbal.

System Settings

General: Includes the Calibrate System, Binding, operating Wi-Fi frequencies, and gimbal working modes.

Profile: Custom motor configurations can be saved or reset to default settings.

Camera Page

Control camera recording and various other supported settings when a camera control cable is attached.

Charging

Use the provided charging hub and adapter to charge the battery.

Firmware Updating

Update the firmware through the USB-C port and DJI Assistant 2.

Specifications

Voltage	22.8 V
Battery	4280 mAh/97.58Wh
Operating Temperature	-10° to 40°C (14° to 104°F)
Charging Temperature	-10° to 40°C (14° to 104°F)
Battery Life	18 hours
Charging Time	1.5 hours
DC IN	12 V - 27 V
DC OUT	14.4 V / 8A Max
Operating Frequency	2408MHz~2475.5MHz & 5729MHz~5843MHz
Transmitter Power	20.60dBm for 2.4G & 22.20dBm for 5.8G
Modulation Mode	GFSK
Max. of Antenna Gain	2.18dBi for 2.4G & 4.5dBi for 5.8G

Compliance Information

FCC Compliance Notice

This device complies with Part 15 of the FCC Rules. Operation is subject to the following two conditions:

- (1) This device may not cause harmful interference, and
- (2) This device must accept any interference received, including interference that may cause undesired operation.

Any changes or modifications not expressly approved by the party responsible for compliance could void the user's authority to operate the equipment.

This equipment has been tested and found to comply with the limits for a Class B digital device, pursuant to part 15 of the FCC Rules. These limits are designed to provide reasonable protection against harmful interference in a residential installation. This equipment generates, uses and can radiate radio frequency energy and, if not installed and used in accordance with the instructions, may cause harmful interference to radio communications. However, there is no guarantee that interference will not occur in a particular installation. If this equipment does cause harmful interference to radio or television reception, which can be determined by turning the equipment off and on, the user is encouraged to try to correct the interference by one or more of the following measures:

- Reorient or relocate the receiving antenna.
- Increase the separation between the equipment and receiver.
- Connect the equipment into an outlet on a circuit different from that to which the receiver is connected.
- Consult the dealer or an experienced radio/TV technician for help.

RF Exposure Information

This equipment complies with FCC radiation exposure limits set forth for an uncontrolled environment. This transmitter must not be co-located or operating in conjunction with any other antenna or transmitter. This equipment should be installed and operated with minimum distance 20cm between the radiator&your body.

ISED RSS Warning

This device complies with ISED licence-exempt RSS standard (s). Operation is subject to the following two conditions: (1) this device may not cause interference, and (2) this device must accept any interference,including interference that may cause undesired operation of the device.

Le présent areil est conforme aux CNR d'ISED licables aux areils radio exempts de licence.

L'exploitation est autorisée aux deux conditions suivantes:

- (1) l'areil ne doit pas produire de brouillage, et
- (2) l'utilisateur de l'appareil doit accepter tout brouillage radioélectrique subi, même si le brouillage est susceptible d'en compromettre le fonctionnement.

ISED Radiance Exposure Statement:

This equipment complies with ISED RF radiation exposure limits set forth for an uncontrolled environment. This transmitter must not be co-located or operating in conjunction with any other antenna or transmitter.

This equipment should be installed and operated with minimum distance 20cm between the radiator & your body.

Cet appareil est

Conforme aux limites d'exposition de rayonnement RF ISED établies pour un environnement non contrôlé.

Cet émetteur ne doit pas être co-implanté ou fonctionner en conjonction avec toute autre antenne ou transmetteur.

Cet équipement doit être installé et utilisé avec une distance minimale de 20cm entre le radiateur & votre corps.

Any Changes or modifications not expressly approved by the party responsible for compliance could void the user's authority to operate the equipment.

KCC Warning Message

“해당 무선설비는 운용 중 전파혼신 가능성이 있음”



인증받은자의 상호: SZ DJI Osmo Technology Co., Ltd.

제품명/모델명: 특정소출력무선기기(무선데이터통신시스템용무선기기)RS1

제조사및제조국가: SZ DJI Osmo Technology Co.,Ltd. /China

제조년월: 2018-04

인증번호: R-CRM-osm-MST1

해당 무선설비는 전파혼신 가능성이 있으므로 인명안전과 관련된 서비스는 할 수 없음

NCC Warning Message

低功率電波輻射性電機管理辦法

第十二條 經型式認證合格之低功率射頻電機，非經許可，公司、商號或使用者均不得擅自變更頻率、加大功率或變更原設計之特性及功能。

第十四條 低功率射頻電機之使用不得影響飛航安全及干擾合法通信；經發現有干擾現象時，應改善至無干擾時方得繼續使用。前項合法通信，指依電信法規定作業之無線電通信。低功率射頻電機須忍受合法通信或工業、科學及醫療用電波輻射性電機設備之干擾。

EU Compliance Statement: SZ DJI Osmo Technology Co., Ltd. hereby declares that this device is in compliance with the essential requirements and other relevant provisions of the RED Directive.

A copy of the EU Declaration of Conformity is available online at www.dji.com/euro-compliance.



Warning: Operation of this equipment in a residential environment could cause radio interference.

EU contact address: DJI GmbH, Industriestrasse. 12, 97618, Niederlauer, Germany

Declaración de cumplimiento UE: SZ DJI Osmo Technology Co., Ltd. por la presente declara que este dispositivo cumple los requisitos básicos y el resto de provisiones relevantes de la RED Directiva.

Hay disponible online una copia de la Declaración de conformidad UE en www.dji.com/euro-compliance.

Dirección de contacto de la UE: DJI GmbH, Industriestrasse. 12, 97618, Niederlauer, Germany

EU-verklaring van overeenstemming: SZ DJI Osmo Technology Co., Ltd. verklaart hierbij dat dit apparaat voldoet aan de essentiële vereisten en andere relevante bepalingen van RED Richtlijn.

De EU-verklaring van overeenstemming is online beschikbaar op www.dji.com/euro-compliance

Contactadres EU: DJI GmbH, Industriestrasse. 12, 97618, Niederlauer, Germany

Declaração de conformidade da UE: A SZ DJI Osmo Technology Co., Ltd. declara, através deste documento, que este dispositivo está em conformidade com os requisitos essenciais e outras disposições relevantes da RED Diretiva.

Existe uma cópia da Declaração de conformidade da UE disponível online em www.dji.com/euro-compliance

Endereço de contacto na UE: DJI GmbH, Industriestrasse. 12, 97618, Niederlauer, Germany

Dichiarazione di conformità UE: SZ DJI Osmo Technology Co., Ltd. dichiara che il presente dispositivo è conforme ai requisiti essenziali e alle altre disposizioni rilevanti della RED direttiva.

Una copia della dichiarazione di conformità UE è disponibile online all'indirizzo Web www.dji.com/euro-compliance

Indirizzo di contatto UE: DJI GmbH, Industriestrasse. 12, 97618, Niederlauer, Germany

Déclaration de conformité UE : Par la présente, SZ DJI Osmo Technology Co., Ltd. déclare que cet appareil est conforme aux principales exigences et autres clauses pertinentes de la RED directive européenne.

Une copie de la déclaration de conformité UE est disponible sur le site www.dji.com/euro-compliance

Adresse de contact pour l'UE : DJI GmbH, Industriestrasse. 12, 97618, Niederlauer, Germany

EU-Compliance: Hiermit erklärt SZ DJI Osmo Technology Co., Ltd., dass dieses Gerät den wesentlichen Anforderungen und anderen einschlägigen Bestimmungen der RED-Richtlinie entspricht.

Eine Kopie der EU-Konformitätserklärung finden Sie online auf www.dji.com/euro-compliance.

Kontaktadresse innerhalb der EU: DJI GmbH, Industriestrasse. 12, 97618, Niederlauer, Germany

CAUTION: RISK OF EXPLOSION IF BATTERY IS REPLACED BY AN INCORRECT TYPE. DISPOSE OF USED BATTERIES ACCORDING TO THE INSTRUCTIONS

Environmentally friendly disposal

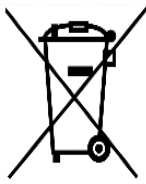

Old electrical appliances must not be disposed of together with the residual waste, but have to be disposed of separately. The disposal at the communal collecting point via private persons is for free. The owner of old appliances is responsible to bring the appliances to these collecting points or to similar collection points. With this little personal effort, you contribute to recycle valuable raw materials and the treatment of toxic substances.

Thailand Warning message

เครื่องโทรคมนาคมและอุปกรณ์นี้ มีความสอดคล้องตามข้อกำหนดของ กทช.

Mexico Warning message

“La operación de este equipo está sujeta a las siguientes dos condiciones: (1) es posible que este equipo o dispositivo no cause interferencia perjudicial y (2) este equipo o dispositivo debe aceptar cualquier interferencia, incluyendo la que pueda causar su operación no deseada.”

Brazil Warning message

Este equipamento opera em caráter secundário, isto é, não tem direito a proteção contra interferência prejudicial, mesmo de estações do mesmo tipo, e não pode causar interferência a sistemas operando em caráter primário

UAE logo requirements

The characters shall appear in black print against a white background.

No character shall be less than 2mm in height.

The letters “TRA” shall be atleast 3mm in height.