

DJI LIGHTBRIDGE

User Manual v1.00

2014.02.26

Disclaimer

Thank you for purchasing this DJI product. Please visit the LIGHTBRIDGE page on www.dji.com regularly to keep up with product information, technical updates and manual corrections. Information in this manual is subject to change without notice in line with product upgrades and updates.

In using this product, you hereby agree to this disclaimer and signify that you have all points completely. When assembling this product, follow all instructions carefully. The manufacturer and seller assume no liability for any damage or injury arising from the use of this product.

DJI is a registered trademark of DJI Innovations. Names of product, brand, etc., appearing in this manual are trademarks or registered trademarks of their respective owner companies. This product and manual are copyrighted by DJI Innovations with all rights reserved. No part of this product or manual shall be reproduced in any form without the prior written consent or authorization of DJI Innovations. No patent liability is assumed with respect to the use of the product or information contained herein.

About

Working in 2.4GHz frequency band, an air unit and a ground unit compose the LIGHTBRIDGE, which transmits video image, flight controller OSD and transmitter control signal. Having the characteristics of small dimension, low power consumption and high sensitivity, the LIGHTBRIDGE can be widely applied in various fields for wireless communication. For aeromodelling activity, attach the air unit to the aircraft and connect the ground unit to a monitor for displaying the video image, flight controller OSD information.

When the LIGHTBRIDGE transmits the video image and flight controller OSD information, the air unit is working as transmitting equipment and the ground unit as receiving equipment. The air unit gets the video image from a camera and OSD information from the flight controller, modulates and wirelessly transmits it to the ground unit. The ground unit receives the information, demodulates and sends it to display on a monitor or a smart phone. To obtain a better experience, download the DJI LIGHTBRIDGE App via a smart phone for displaying the video image and flight controller OSD information.

When the LIGHTBRIDGE transmits the transmitter control signal, the ground unit is working as transmitting equipment connecting with transmitter and the air unit as receiving equipment built in a receiver. The ground unit can connect to two transmitters for both aircraft and gimbal control. It should be used with the DJI flight control system via the DBUS port connection since the built-in receiver can only support DJI DBUS protocol.



* For the 2.4GHz transmitter, it should be correctly connected to the ground unit, otherwise may lead to malfunction due to interference.

Contents



Disclaimer	2
About	2
Contents	3
In the Box.....	4
Introduction	7
Air Unit.....	7
Ground Unit.....	8
Connection	12
Air unit Connection.....	12
Ground Unit Connection	13
Install Antennas.....	13
Usage	18
Link.....	18
Download DJI LIGHTBRIDGE App.....	18
Usage Procedure	18
DJI LIGHTBRIDGE App Usage	20
Specification	21
Appendix.....	23
Re-link	23
Recharge Ground Unit.....	23
FCC and IC Statements	24

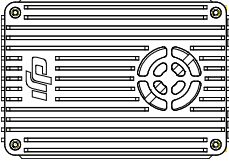
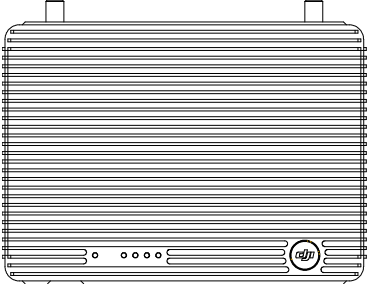

In the Box

Modules



Air unit×1	Ground unit×1
	
Air unit antennas×2	Ground unit antennas×2
	

Air unitcables

GIMBAL cable ×1	
<p>Connect the CAN-Bus connector to flight control system for obtaining OSD information and the power connector to battery for power supply. DVSB connector is reserved.</p>	
DBUS cable ×1	
<p>Connect to the flight control system DBUS port for communication.</p>	
AV cable ×1	

<p>Connect to an analog video signal device.</p>	
<p>HDMI cable ×1</p>	
<p>Connect to the HDMI port on the camera.</p>	
<p>Micro-USB cable ×1</p>	
<p>Connect to a PC for firmware upgrade via the DJI Assistant Software.</p>	

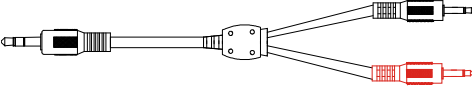
Ground unit cables

<p>Transmitter cable ×1</p>	
<p>Connect to the training port cable, with the red port for aircraft control and the black port for gimbal control.</p>	
<p>Training port cable with rectangular head ×1, Training port cable with circle head ×1</p>	
<p>Connect to the transmitter's training port.</p>	

Charger ×1

For charging the ground unit.

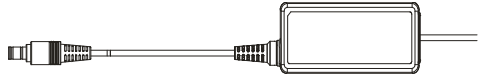

Charger cable ×1

Connect the charger to a wall socket. Choose an appropriate adapter for the wall socket.



Battery charger cable×1

Connect to a battery (3S~6S) for charging the ground unit.

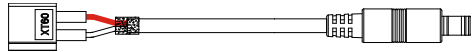

Introduction

Air Unit

Front view

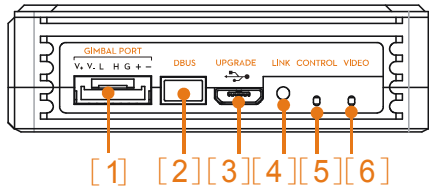

[1] GIMBAL PORT

Port functions shown as below:

- i. Power supply: (V+,V-) Connect to the on-board battery.
- ii. CAN-Bus: (L,H) Connect to the flight control system CAN-Bus port for obtaining flight control system OSD information.
- iii. DVSB: (G,-,+) For DJI high end gimbal DVSB video streaming input.

[2] DBUSport

Built-in receiver interface should be connected to DJI flight control system's DBUS port usually locating at main controller labeled X2.

[3] UPGRADE port

Connect **UPGRADE** port to the USB port on a PC for firmware upgrade via the DJI Assistant Software.

[4] LINK button

Press the **LINK** button to link the air unit with the ground unit.



[5] CONTROL indicator

Transmitter link indicator is for display the communication status between air and ground unit.

Indicator	Description	Action
●●●●●●	No signal	Power on the ground unit, and check the distance between ground unit and air unit.
●●●●●●	Signal is detected but not linked.	Linking is required.
■	Successfully linked.	Proper functioning.

[6] VIDEO indicator

Video indicator shows the transmission status of the video source.

Indicator	Description	Instruction
	AV/HDMI signal is detected and proper functioning.	Proper functioning.
	AV/HDMI signal is detected but transmission failed.	Power cycle is required.
	No video source is detected.	Check camera and connection status.

Top view

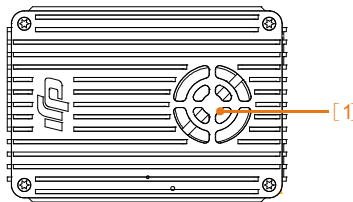

[1] Ventilation Fan

To ensure the fan works properly, do not obstruct the ventilation fan outlet when installing.

Side View

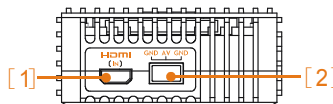

[1] HDMI IN Port

Connects to the HDMI input device.

[2] AV Port

Connects to the analog video input device.

Tip: Select the appropriate port according to the video source format of the input device.

Ground Unit

Front View

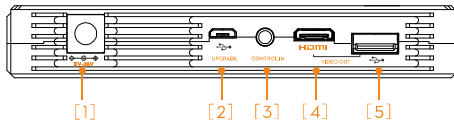

[1] Power Adapter Port(11V~26V)

Connect the power adapter or a 3S~6S battery to this port to charge the built-in battery. If use a 3S~6S battery, the ground end comes with the protection function, which prevents the 3S~6S batter from over discharge. When the ground unit is connected with the external power adapter or battery, the built-in battery disables itself and switch to external power source. Beware of the input voltage range, do not exceed the operating range (11~26V).

[2] UPGRADE Port

Connect to a PC to upgrade the firmware by using the Assistance Software.

[3] CONTROL IN Port

Connect the training port and the CONTROL IN port on the ground unit using the training port output cable and remote control cable.

[4] HDMIOUT Port

Connect to a HDMI supported monitor to view the video and OSD from the flight control system.

[5] USBPort

Connect to a smart phone to view the video and OSD from the flight control system by using the DJI Lightbridge App.

Top View

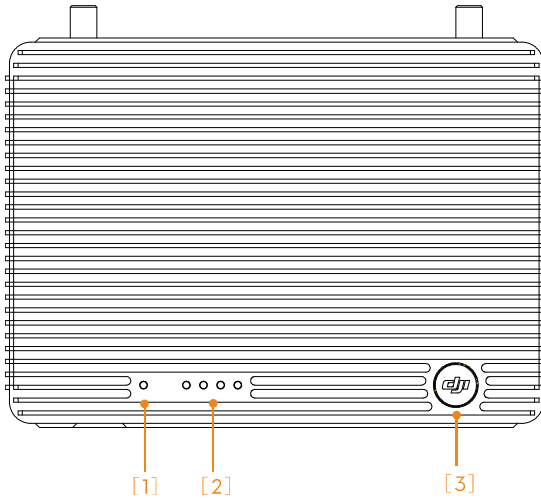

[1] VIDEO Indicator

Vedio transmission linkage indicator, used together with the air unit remote controller to reflect the connection status between the air unit and ground unit.

Indicator	Description
	Signal detected from the air unit and ground unit works normally.
	Signal undetected from the air unit but ground unit works normally.

[2] POWER Indicator

Dynamically shows the battery capacity of the ground unit.

Indicator	BatteryCapacity
	87.5%~100%
	75%~87.5%
	62.5%~75%
	50%~62.5%
	37.5%~50%
	25%~37.5%
	12.5%~25%
	0%~12.5%
	= 0%

 Solid green

 Flashing green

 Off

[3] **Power Button**

Power on: Press the button once and hold to the button for more than 2 seconds to power on.

Power off: Press the button once and press the button again to power off.

Show capacity: Press the button once to display the capacity of the battery.

Connection

Air unit Connection

Install Antennas

Insert the antennas to the position shown in the illustration below. Ensure that you heard a 'click' sound to confirm the antennas are in place.

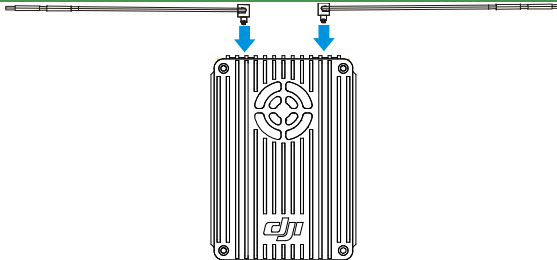

Notice

- (1) Install the antennas before the air unit is powered on.
- (2) When in using, placed the antennas downward and keep it unobstructed to ensure the transmission signal quality.
- (3) Ensure to use the special antennas and install them by a professional trained. Any other types of antennas are forbidden.

Video Source Connection

- DJI Lightbridge supports both the HDMI and AV input. Refer to the illustration below for connection. For HDMI input, connect the HDMI cable to the HDMI port on the camera. For AV input, connect the AV cable to the AV output port on the camera. When using the DJI gimbal, connect to the video output port on the GCU model. The illustration below use the DJI GCU as the example.

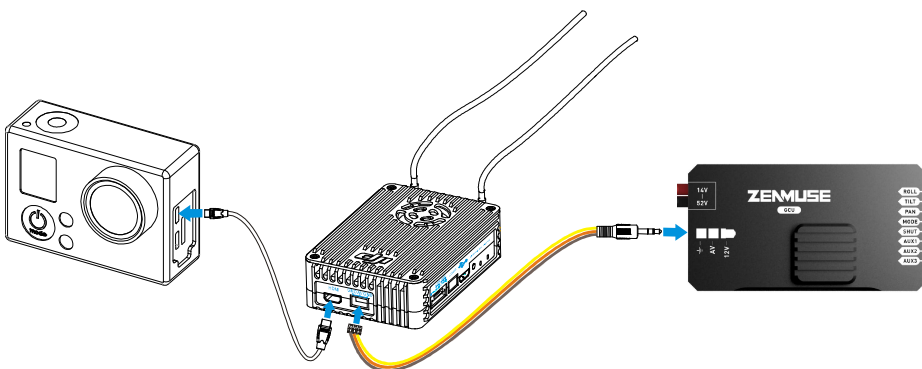

Connect to Flight Control System

Currently the only flight system control that Lightbridge supported is DJI A2, refer to the user manual of DJI A2 to complete the following connection:

1. Connect the DBUS cable to the DBUS port (X2 port) on the DJI A2 flight control system.
2. GIMBAL PORT provides three functions, they are CAN-Bus, power supply and DVSB connection. The DVSB port is a reserved port that should not be connected. For the air unit connection, connect the CAN-Bus port to the CAN-bus port, and connect the other end to CAN 1 port on the flight control. Select an appropriate power plug to connect the battery.

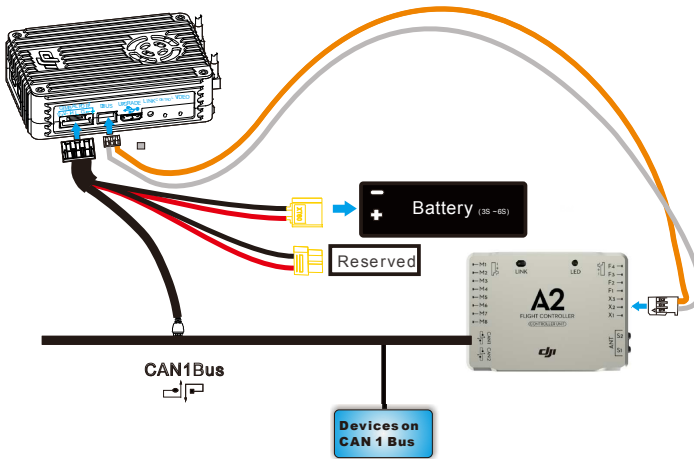

Caution

Connect the air unit to one of the CAN-Bus port that attached to the CAN 1 bus. Do not connect the air unit to the CAN 2 port.

Ground Unit Connection

Install Antennas

Attach two antennas to the ground unit according to the illustration shown below. Screw tight the antennas.

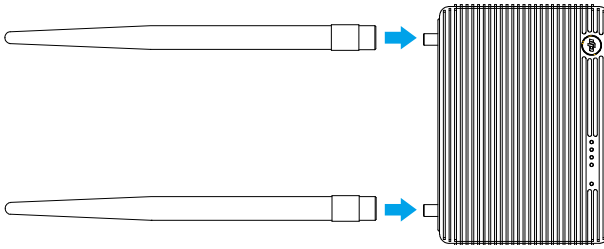

Caution

- (1) Be sure to attach the antennas before power on the ground unit, otherwise it may cause damages to the device.
- (2) Ensure to use the special antennas and install them by a professional trained. Any other types of antennas are forbidden.

Remote Controller Connection

Connect the training port and the CONTROL IN port on the ground unit by using the training port output cable and remote control connection cable. The supported remote control includes: Futaba, Spektrum, Devention and JR remote controller. Refer to the corresponding remote controller manuals for detailed usage.

Two remote controllers can be connected to the ground unit at the same time, follow the illustration below for the connection:

- Red jack connects to the remote controller for the aircraft.
- Black jack connects to the remote controller for the gimbal.

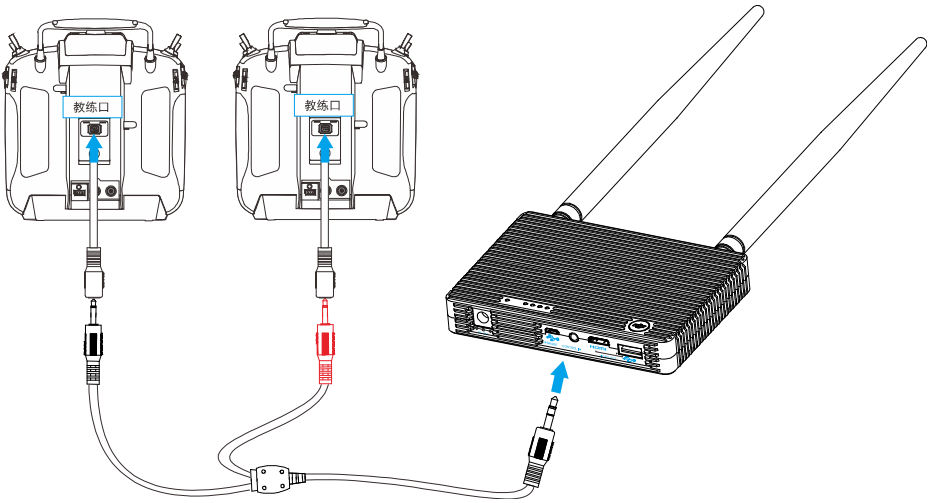

Transmitter Configuration

Refer to your own remote controller for reference. The below configuration process is based on Futaba T8FG as the example:

1. Switch off the RF option. The below procedure takes the Futaba T8FG as the example:
 - a) Press and hold the [RTC] button to switch on the remote controller.
 - b) Enter [POWR MODE] menu, select [RF OFF].

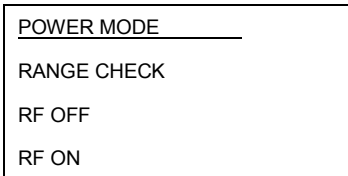

- c) RF indicator turns off and configuration success.
2. Set the [TRAVEL] value of each channels at the range within 100. The below procedure takes the Futaba T8FG as example:
 - a) Double click the [LINK] button to enter [LINKAGE MENU], select [END POINT] option.
 - b) Enter [END POINT] menu, set the [TRAVEL] value of each channels at the range with 100 as the below table shows:

END POINT					1/3
TRAVEL					
1 AIL	135	100	100	135	
2 ELE	135	100	100	135	
3 THR	135	100	100	135	
4RUD	135	100	100	135	

Caution

In some cases (namely for Futaba T8J remote controller), even though the [TRAVEL] value has been set to 100, but the actual output value may exceeds 100. The inconsistent value can be observed out by checking the [SERVO] in the Linkage show as below (actual GUI may vary from the models).

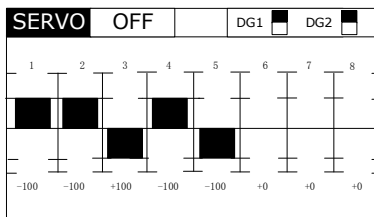

To prevent this situation, you must double check that the actual [TRAVEL] value does not exceed 100, otherwise you should re-configure the value until the requirement of the value is met.

Video Connection

Both HDMI and USB port can output video to the device, however, the selection of the output option is mutually exclusive. Select the video output base on your video device.

- Connect HDMI supported monitor to HDMI OUT port in the ground unit for HDMI viewing. (Coming soon)
- Connect smart phone to USB port on ground unit using USB cable. Use the DJI Lightbridge One app to view video and OSD information from the flight control system in real time. The below illustration uses the USB port connection as the example.

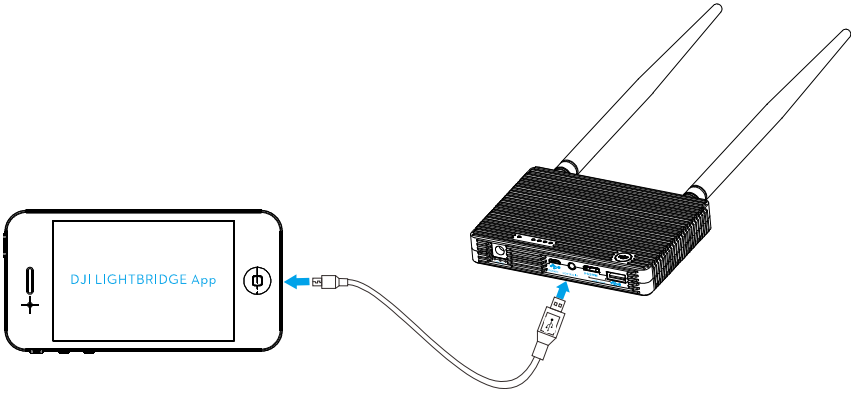

Usage Link

Linking is completed when the Lightbridge is shipped. Start using the product according to the indicators.

Download DJI LIGHTBRIDGE App

Select one of these approaches to download the DJI LIGHTBRIDGE App.

Downloading Approach		
Approach 1		Scan the QR card to obtain the download address for DJI Lightbridge App. Install the DJI Lightbridge App onto the smart phone.
Approach 2	Android User	Access to the Internet and search "DJI Lightbridge" in the Google Play and install the DJI Lightbridge App onto the smart phone.
Beware of the update notification from the DJI official website and the Google Play to obtain the latest version of DJI Lightbridge App.		
Supported Smart phone		
Android (Version 4.1.2 or later)		Samsung Galaxy S3 , S4 , Note2 , Note3, etc.

Usage Procedure

1. Power on the air unit first then the ground unit, wait until the [POWER] indicator is solid on.
2. Observe the [VIDEO] indicator on the ground unit is solid, follow by the [CONTROL] indicator, and finally observe the flash green indicator for the [VIDEO] that shows the ground unit and the air unit are communicating normally.
3. Launch the DJI Lightbridge App on your smart phone. If the preview image appears on the smart phone then it means the system is working normally.
4. Real time OSD information is available when the flight control system is working normally.

Notice

- (1) Position the air unit antennas downward and the ground unit antennas upward and ensure there is no obstacle between the air unit antennas and ground unit antenna otherwise the transmission distance may be affected.
- (2) When the air unit is receiving signals, both the antennas stop transmitting signals, one of the antenna starts receiving signals. Both antennas resume transmitting signals when the receiving

operation is completed.

- (3) When the ground unit is receiving signals, both the antennas stop transmitting signals and start receiving signals. When the ground unit is transmitting signals, the antennas stop receiving signals and one of the antennas starts transmitting signals.

DJI LIGHTBRIDGE App Usage

DJI LIGHTBRIDGE App can display information feed by the flight control system. The OSD information is shown as below:

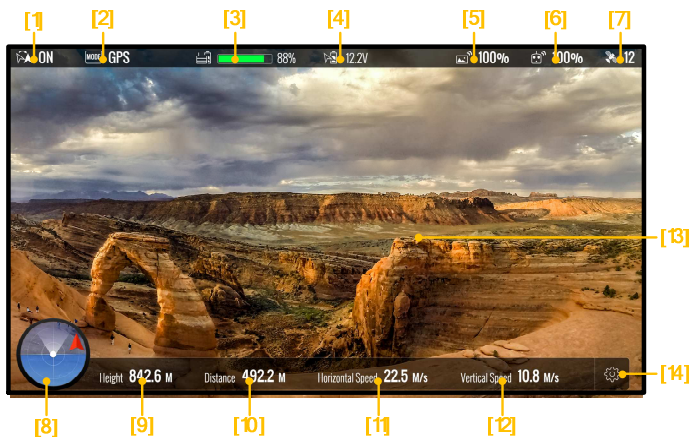

- [1] IOC Status
ON : Enabled
OFF : Disabled
- [2] Control mode of the flight control system
- [3] Ground unit power capacity
- [4] Air unit power capacity
- [5] Transmission status
- [6] Remote controller status
- [7] GPS satellite count
- [8] Air craft nose orientation
- [9] Aircraft altitude
- [10] Aircraft flight distance (distance between the current position and the recorded Go Home position, only display when GPS signal is normal and Go Home position is recorded, display N/A otherwise)
- [11] Vertical speed of the aircraft
- [12] Horizontal speed of the aircraft
- [13] Preview window
- [14] Set up

Specification

Performance Parameters	
Transmission Distance(outdoor and unobstructed)	1.2Km
EIRP	100mW
Receiver Sensitivity (1%PER)	-101dBm ± 2dBm
Radio Frequency(Air Unit)	CH1-CH8
	● CH1 : 2406.5MHz ● CH5 : 2446.5MHz
	● CH2 : 2416.5MHz ● CH6 : 2456.5MHz
	● CH3 : 2426.5MHz ● CH7 : 2466.5MHz
	● CH4 : 2436.5MHz ● CH8 : 2476.5MHz
Radio Frequency(Ground Unit)	CH1-CH36
	● CH1 : 2405.376MHz ● CH19 : 2442.24MHz
	● CH2 : 2407.424MHz ● CH20 : 2444.288MHz
	● CH3 : 2409.472MHz ● CH21 : 2446.336MHz
	● CH4 : 2411.52MHz ● CH22 : 2448.384MHz
	● CH5 : 2413.568MHz ● CH23 : 2450.432MHz
	● CH6 : 2415.616MHz ● CH24 : 2452.48MHz
	● CH7 : 2417.664MHz ● CH25 : 2454.528MHz
	● CH8 : 2419.712MHz ● CH26 : 2456.576MHz
	● CH9 : 2421.76MHz ● CH27 : 2458.624MHz
	● CH10 : 2423.808MHz ● CH28 : 2460.672MHz
	● CH11 : 2425.856MHz ● CH29 : 2462.72MHz
	● CH12 : 2427.904MHz ● CH30 : 2464.768MHz
	● CH13 : 2429.952MHz ● CH31 : 2466.816MHz
	● CH14 : 2432MHz ● CH32 : 2468.864MHz
	● CH15 : 2434.048MHz ● CH33 : 2470.912MHz
	● CH16 : 2436.096MHz ● CH34 : 2472.96MHz
	● CH17 : 2438.144MHz ● CH35 : 2475.008MHz
	● CH18 : 2440.192MHz ● CH36 : 2477.056MHz
Antenna Gain (Air Unit)	2.5dBi
Antenna Gain (Ground Unit)	4.68dBi

Physical Parameters	
Operating Temperature	-10~50°C
Dimension (no antennas)	<ul style="list-style-type: none"> ● Air unit : 68cm(L)X48cm(W)X21cm(H) ● Ground unit : 125cm(L)X90cm(W)X20cm(H)
Gross Weight (no antennas)	<ul style="list-style-type: none"> ● Air unit : 71g ● Ground unit : 295g
Hardware Functions Supported	
Antenna connector	MMCX Male (air unit) , SMA Male (ground unit)
Air unit operating voltage	3S~6S
Ground unit operating voltage	3S~6S
Air unit operating amperage	700mA ± 20mA(@12V)
Ground unit operating amperage	600mA ± 10mA(@12V)

Appendix

Re-link

Follow the below instruction to re-link the air unit and the ground unit when the initial linking is failed.

1. Maintain a distance of 0.5m to 1m between the air unit and the ground unit, power on the air unit and then the ground unit.
2. Use a pin to press the **[LINK]** button on the air unit. Press and hold on for 5 seconds then release.
3. When re-link is finished, The **[CONTROL]** indicator on air unit turns solid green.

Recharge Ground Unit

1. Connect the plug adapter to the power adapter before attach the power adapter to the ground unit. Plug the power adapter to power outlet to start recharging. Or connect to a 3S~6S battery with the Battery charger cable.
2. **[Power]** indicator shows green shows charging in process.
3. **[Power]** indicator turns off shows the charging is completed.

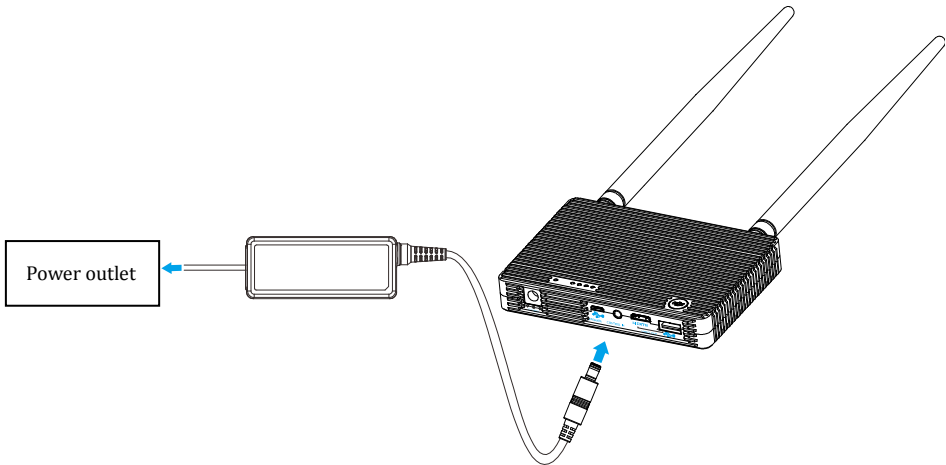

FCC and IC Statements

This device and its antenna must not be located or operating in conjunction with any other antenna and transmitter.

This device complies with part 15 of the FCC rules. Operation is subject to the following two conditions: (1) this device may not cause harmful interference, and (2) this device must accept any interference received, including interference that may cause undesired operation.

NOTE:The manufacturer is not responsible for any radio or TV interference caused by unauthorized modifications to this equipment. Such modifications could void the user's authority to operate the equipment.

NOTE: This equipment has been tested and found to comply with the limits for a Class B digital device, pursuant to part 15 of the FCC Rules. These limits are designed to provide reasonable protection against harmful interference in a residential installation. This equipment generates uses and can radiate radio frequency energy and, if not installed and used in accordance with the instructions, may cause harmful interference to radio communications. However, there is no guarantee that interference will not occur in a particular installation. If this equipment does cause harmful interference to radio or television reception, which can be determined by turning the equipment off and on, the user is encouraged to try to correct the interference by one or more of the following measures:

- Reorient or relocate the receiving antenna.
- Increase the separation between the equipment and receiver.
- Connect the equipment into an outlet on a circuit different from that to which the receiver is connected.
- Consult the dealer or an experienced radio/TV technician for help.

Changes or modifications not expressly approved by the party responsible for compliance could void the user's authority to operate the equipment.

For Air unit

This radio transmitter (11805A-201402240) has been approved by Industry Canada to operate with the antenna types listed below with the maximum permissible gain and required antenna impedance for antenna type indicated. Antenna types not included in this list, having a gain greater than the maximum gain indicated for that type, are strictly prohibited for use with this device.

Manufacturer	Model	Connect Type	Maximum Gain	Impedance
INVAX System Technology Corp.	AN2400-06169GMX	MMCX Male	2.5 dBi	50 Ohm

For Ground unit

This radio transmitter (11805A-201402241) has been approved by Industry Canada to operate with the antenna types listed below with the maximum permissible gain and required antenna impedance for antenna type indicated. Antenna types not included in this list, having a gain greater than the maximum gain indicated for that type, are strictly prohibited for use with this device.

Manufacturer	Model	Connector Type	Maximum Gain	Impedance
INVAX System Technology Corp.	AN2400-9297SM	SMA Male	4.68 dBi	50 Ohm

This device complies with Industry Canada licence-exempt RSS standard(s). Operation is subject to the following two conditions: (1) this device may not cause interference, and (2) this device must accept any interference, including interference that may cause undesired operation of the device.

Le présent appareil est conforme aux CNR d'Industrie Canada applicables aux appareils radio exempts de licence. L'exploitation est autorisée aux deux conditions suivantes : (1) l'appareil ne doit pas produire de brouillage, et (2) l'utilisateur de l'appareil doit accepter tout brouillage radioélectrique subi, même si le brouillage est susceptible d'en compromettre le fonctionnement.

When using the device, ensure that the antenna of the device is at least 20 cm away from all persons.

Hereby, SZ DJI TECHNOLOGY CO. LTD declares that this device is in compliance with the essential requirements and other relevant provisions of Directive 1999/5/EC.