

DJI FOCUS

Wireless Lens Control System

User Manual

V1.0 2015.09

Disclaimers and Warnings

Congratulations on purchasing your new DJI product. Please read this manual and disclaimer carefully before using this product. By using this product, you hereby agree to this disclaimer and signify that you have read it fully. You agree that you are responsible for your own conduct and any content created while using this product, and for any consequences thereof. You agree to use this product only for purposes that are proper and in accordance with local regulations, terms and any applicable policies and guidelines.

By reading this disclaimer, you also agree:

1. Any part of this disclaimer is subject to change without prior notice, refer to www.dji.com for the latest version.
2. DJI reserves the right of final interpretation of this disclaimer.

As DJI has no control over use, setup, final assembly, modification or misuse, no liability shall be assumed or accepted for any resulting damage or injury. By the using, setting up, or assembling of the product, the user accepts all resulting liability. DJI assumes no liability for damages or injuries incurred directly or indirectly from the use of this product.

DJI is registered trademark of DJI. All names of products, brands, etc., appearing in this manual are trademarks or registered trademarks of their respective owner companies. This product and manual are copyrighted by DJI, with all rights reserved. No part of this product or manual shall be reproduced in any form without the prior written consent or authorization of DJI. No patent liability is assumed with respect to the use of the product or information contained herein.

***Navigating to a Topic**

View a complete list of topics in the table of contents. Click on a topic to navigate to that section.

***Searching for Keywords**

Search for keywords such as “battery” and “install” to find a topic. If you are using Adobe Acrobat Reader to read this document, press Ctrl+F on Windows or Command+F on Mac to begin a search.

Using this Manual

Legend



Important









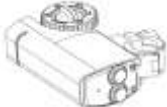

Tips

Content

Disclaimers and Warnings	2
Using this Manual	3
Legend	3
In the Box	5
Introduction	6
Controller	6
Motor	8
Installation.....	8
Mounting Antenna	8
Mounting Follow Focus Ring	9
Mounting the Motor	10
Binding	11
System Status LED Information	12
Settings.....	13
Calibrate	13
Menu.....	14
Quick Focus Settings	15
Locking Buttons.....	15
Using with Zenmuse X5.....	16
Connection.....	16
Settings.....	17
Upgrade.....	17
Install DJI PC/MAC Assistant.....	17
Upgrade.....	18
Specifications	19

In the Box

Check to ensure that all of the following items are included in the package. If any items are missing, contact DJI or your local dealer.

<p>Controller X 1 Modular hand-held control unit, for controlling Motor.</p>	
<p>Motor X 1 For controlling lens.</p>	
<p>Power Cable X 2 For connecting the motor to an external power supply.</p>	
<p>Signal Cable X 1 Connecting the controller and motor for cable mode or upgrade.</p>	
<p>Marker Ring X 3 For motor control knob.</p>	
<p>Lens Ring X 1 For mounting on the lens. Number of teeth: 105, Module: 0.8, Inner diameter: 60mm</p>	
<p>Lens Ring X 1 Number of teeth: 105, Module: 0.8, Inner diameter: 80 mm</p>	
<p>Lens Ring X 1 Number of teeth: 105, Module: 0.8, Inner diameter: 70 mm</p>	
<p>Lens Ring X 1 Number of teeth: 105, Module: 0.8, Inner diameter: 90 mm</p>	
<p>Strap X 1 For carrying the controller around the neck or over a shoulder between takes.</p>	

Introduction

The DJI Focus is a professional Wireless Lens Control System, consist with a controller and motor. The controller is the modular hand-held control unit, with ergonomic design and a simple, intuitive interface for controller the motor. The motor is virtually silent at less than 25 dB(when motor speed is at 96 rpm), its maximum speed can up to 192 rpm, and the maximum torque can reach at 0.35Nm. The DJI Focus is able to work on wireless mode and cable mode, the max transmission distance is 100 m.

Controller

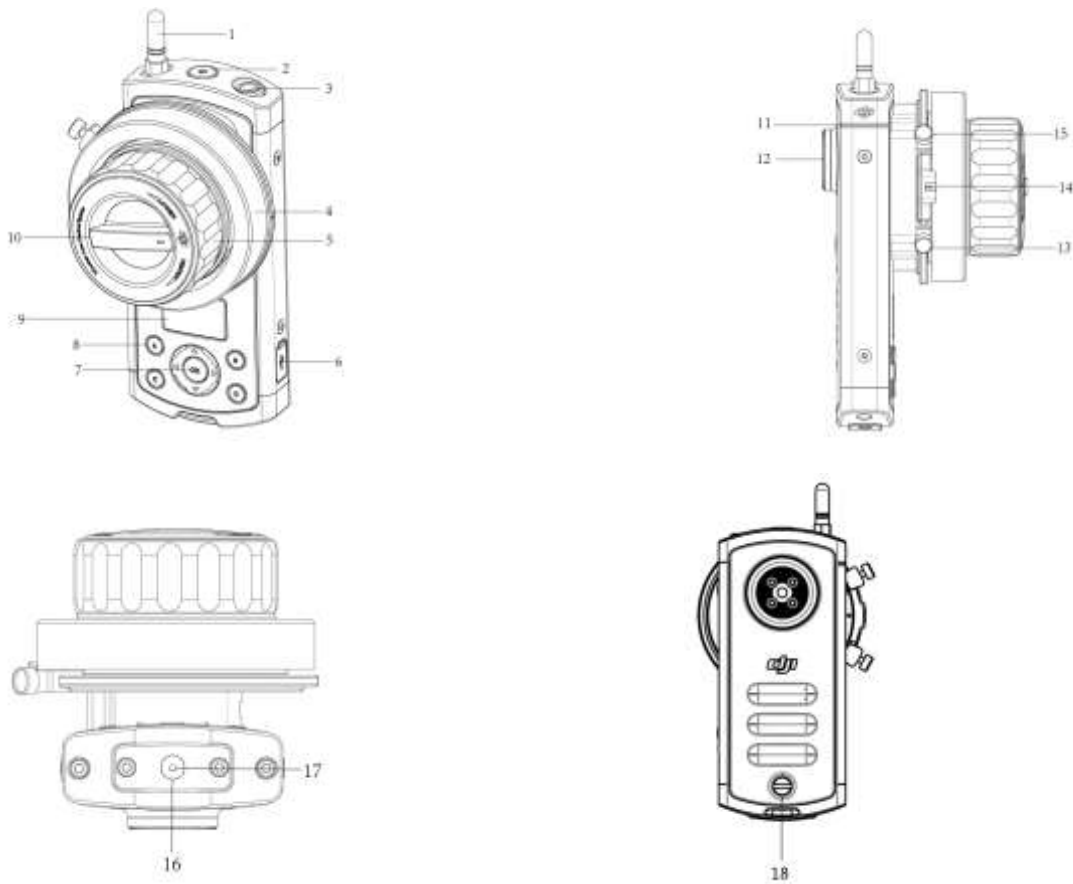

1. Antenna

The operating frequency is 2.4 GHz.

2. Power Button

Press the power button and hold it for 2 seconds to turn on/off the controller.

3. Data Port

To communicate with the motor by connecting the data ports on the controller and motor, and

also can be used to upgrade.

4. Marker Ring

For marking scale values, it can be exchanged easily.

5. Control Knob

For controlling motor by turning the control knob.

6. Micro USB Port

For charging or upgrading the controller via a micro USB cable.

7. Menu Button

Including an OK button and four direction buttons.

8. Quick Focus Buttons

A, B, C, D buttons are separately represent a corresponding focus value, you may pre-set the focus and quickly switch to your desired focus by pressing the button.

9. OLED Screen

Displays the communication status, battery level and menu.

10. Damping Control Knob

The damping of the control knob can be adjusted by this knob.

11. System Status LED

Indicates the system status.

12. Reserved Plate Mount

Reserved.

13. 14 Mechanical Limits

Control knob limits allow you to use a portion of the knob rotation to control the corresponding portion of lens scale.

15. LED

For LED scale illumination.

16. Strap mounting Hole

For mounting the Strap.

17. Bind Button

For binding with the motor or enabling force upgrade.

18. Screw

To remove the cover of the controller by loosen this screw, so that you can replace the battery.

Motor

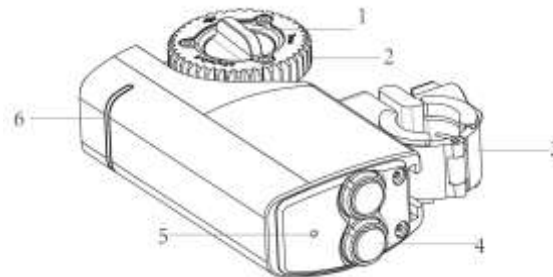

1. Gear Screw

For secure the gear, the gear can be mounted on both sides of the motor.

2. Gear

For controlling the lens.

3. Quick-released Mount

For mounting the motor on the camera. The mounting place can be adjusted by sliding the mount upward or downward.

4. Power/Data Port

The two ports are the same. Connect the motor to an external power supply through one port. If you are willing to enable cable mode, connect another port to the controller.

5. Bind Button

For binding with the controller.

6. System Status LED

Indicates the system status.

Installation

Mounting Antenna

Tighten the antenna to the mounting position on the controller.



Mounting the Strap

Pull down the switch and attach the strap to the mounting place on the bottom of controller, then release the switch. The fastener is designed to enable the controller to rotate freely. Ensure the fastener is secure.

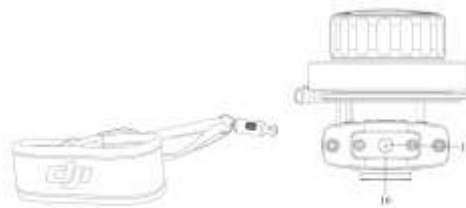

Mounting Lens Ring

DJI Focus provides four different types of lens ring, please choose the proper ring according to your camera lens.

Insert the ring to the lens and tighten the screw. Be sure the ring and the lens make good contact.



If your camera comes with lens ring, please skip this step.

Mounting the Motor

The following steps show how to mount the motor to camera support rods. The motor comes with rod clamp with two inner diameters.

1. Loosen the knob on the quick-release mount and attach the motor to the rod, and adjust the quick-released mount on the motor so that the gear can make full contact with the lens.

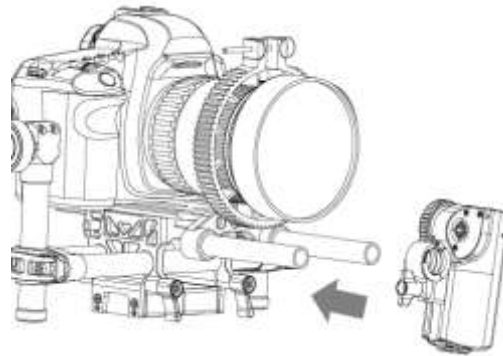

2. Press the gear firmly against the lens and tighten the knob. Ensure the motor gear and the lens ring make good contact.

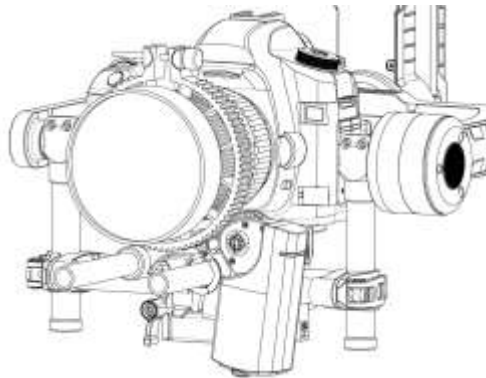

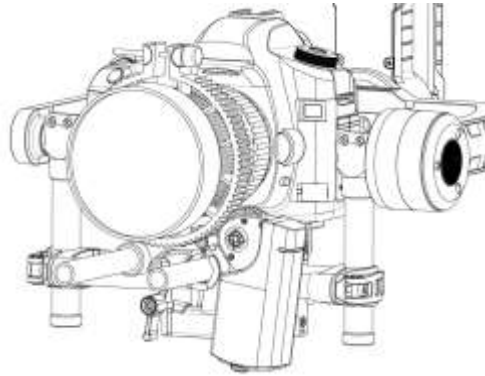

3. Connect the power port on the motor to an external power supply by using the provided power cable. For example, if you are using the camera mounted on the Ronin-M, connect the motor to the P-TAP accessories power port on the Ronin-M.

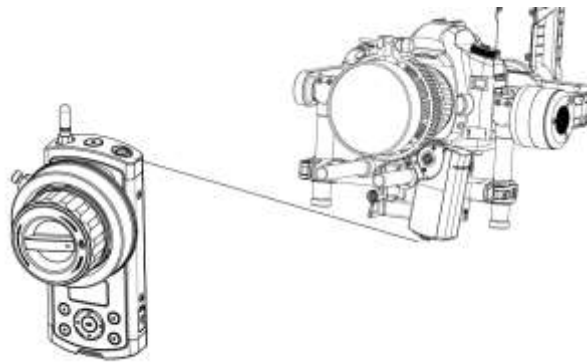

 Make sure the motor is mounted securely.
Do not put your fingers near the motor when it is moving.

4. DJI Focus is able to work on cable mode and wireless mode. If you willing to use cable mode, connect the data port on the controller to the other data port on the motor by using the signal cable.



 If the data ports on the controller and motor is connected, the DJI Focus will work on cable mode and the wireless mode is disable.

Binding

The controller is bind to the motor before delivery. Binding is only required when using a new controller or motor for the first time. Following shows two ways to bind a new controller or motor.

With controller is power on and motor is connected to an external power supply:

1: Press the bind button on the controller, and then press the bind button on the motor within the following 5 seconds. The system status LEDs on both controller and motor blink slowly (blink once in a second) indicates the binding is successful.

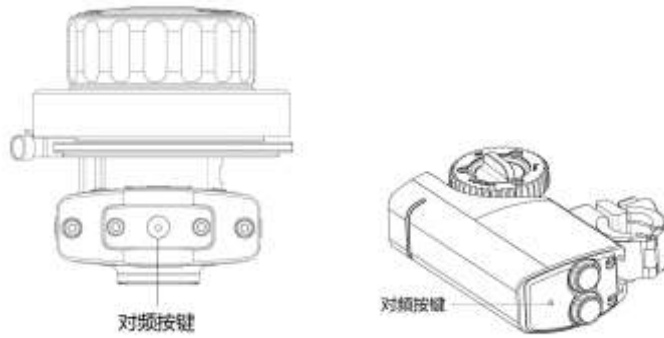

2: On the controller, select Menu->Settings->Connect Motor->Connect, and then press the bind button on the motor within the following 5 seconds. The system status LEDs on both controller and motor blink slowly (blink once in a second) indicates the binding is successful.



System Status LED Information

The system status LED indicates the status for controller and motor.

Controller Status LED	Description
Solid on	The controller is connected to the motor, functioning normally
Blinking quickly (blinks four times a second)	The controller is not connected to the motor / charging
Solid on	Force upgrade (loader mode)
Motor Status LED	Description
Solid on	The controller is connected to the motor, functioning normally
Blinking quickly (blinks four times a second)	The controller is not connected to the motor / overcurrent protection / charging
Solid on	Force upgrade (loader mode)

Settings

Turn on the controller and power on the motor. The OLED of controller will display the following information:

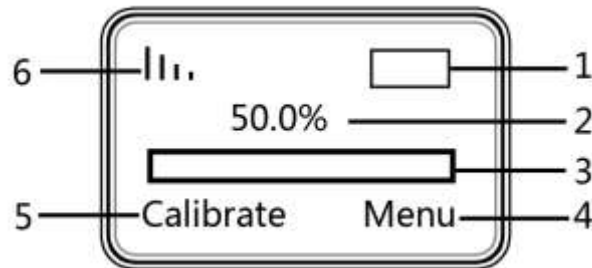

- [1] Battery Level
- [2] Scale Percentage
- [3] Scale Bar
- [4] Menu
- [5] Calibrate
- [6] Signal Strength

Calibrate

To control the lens accurately, you need to know the lens scale by calibrating the motor. The motor must be calibrated once restart it.

Auto

It is recommended to calibrate the motor through the auto calibration if the lens has mechanical limit. Auto calibration use the whole scale of the lens.

On the controller, select 'Calibrate—>Auto', the motor will control the lens to rotate until it reaches the limit. When calibration is complete, select 'Back' to apply. You can suspend the calibration by selecting 'Stop'.

Manual

Manual calibration enables calibration of devices with no mechanical scale stops. To manually calibrate:

1. Manual-Remote

Select 'Calibrate—>Manual-Remote—>Start', press the upward button and hold it to move the motor to your desired value. Press the OK button to 'set'. Then press the downward button and

hold it to move the motor to your desired value, then press the OK button to 'set'. Now you have choose a portion of the lens scale.

The order to press the upward and downward button can be switched.

2. Manual-Hand

To quickly calibrate the motor by hand. Select 'Calibrate—>Manual-Hand—>Start', rotate the lens by hand and choose your desire scale and press OK button to 'set'.

Select 'Back' after the calibration is complete. You can suspend the calibration by selecting 'Stop'.



- You cannot calibrate lens motor while the camera is running.
 - Choose one of the calibration according to your camera lens.
-

Menu

Press the right button or OK button to enter Menu. The motor parameters and system parameters can be configured here. The current firmware version also can be viewed here.

Motor Para

Cali Torque: to set up the auto calibrate stiffness for motor. There are three options: Min, Normal or Max.

Run Torque: set Min, Normal or Max stiffness for motor as needed when controlling the lens.

Speed: Setting the running speed for the motor, providing three options: Slow, Medium or Fast.

Acceleration: Setting the running acceleration for the motor, providing three options: Slow, Medium or Fast.

Rack Speed: Setting the speed when switch the pre-set focus between A, B, C or D. The rack speed can be set among 1% to 100%, and the value is proportional to the Speed and Acceleration.

Direction: Under the 'Normal' setting, the lens rotates in the same direction of the motor control knob. Selecting 'Reverse', the rotate direction of lens and motor control knob will in reverse.

Default: Select 'Default Para' to restore the motor to default settings.

Settings

Power Off: if the controller has been idle for longer than the specified amount of time, it will turn off.

Connect Motor: Select 'Connect' and then press the bind button on the motor within the following 5 seconds to connect the controller with motor.

Endpoint: for setting the scale of controller to control the entire lens scale. Select End Point->Set Point 1, you are setting the starting point. Select Set Point 2, you are setting the end point. This indicates turning the controller move from point 1 to point 2 to control the entire lens scale.

LED Control: to turn on/off the LED and status LED on controller and motor.

Default: to restore the controller settings to default settings.

About

Displays the firmware version that is currently installed on the controller.

Quick Focus Settings

There are four letter buttons A/B/C/D on the controller, which represent four different focus values. You may pre-set the four focus so that you can quickly switch to your desired focus by simply press one button.

Settings

Turn the control knob to control the lens to one focus, then press one of the A/B/C/D buttons and hold it for a while until the corresponding letter appears on the screen, the letter button will blink at that time. The focus has been set.

Press the letter button and hold it for a while will disable the chosen focus. The letter will disappear from the screen.

Apply the Quick Focus

Press the letter button once, the lens will switch to the corresponding focus value, and there will be a tip on the screen. The selected letter button will show solid on while other letter buttons will blink at the same time. Repeat to cancel application.



- After select one of the quick focus, you may still fine tuning the focus by turning the control knob.
 - There are mechanical limits on both control knob and motor. If you are setting the lens scale at 0% or 100%, please mind that you may fail to fine tuning while control knob or motor has reach its mechanical limit.
-

Locking Buttons

All of the buttons on the controller can be locked to avoid wrong operation during usage.

On the main GUI, press and hold the OK button until the lock mark appears on the screen,

indicating all the buttons on the controller are locked and any input is invalid. Repeat to unlock the buttons.

Setting Mechanical Knob Limits

Control knob limits allow you to use a portion of the knob rotation to control the portion lens scale.

1. Loosen the mechanical stops, move one and lock it in your desired position.
2. Move the other mechanical stop so that the space within the two stops represents the portion of the control knob rotation that you wish to define. Lock the stop.

Using with Zenmuse X5

DJI Focus supports the Zenmuse X5 gimbal and camera. Connect the Focus controller to the remote controller will be able to control lens motor of Zenmuse X5.

Connection

Using the provided customizable cable connect the data port on the controller to the CAN Bus port on the Inspire 1 Pro remote controller.

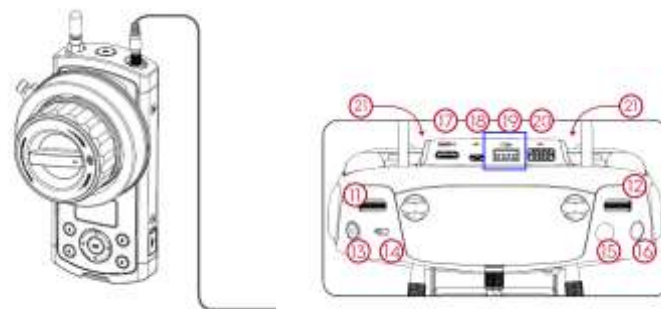

- Make sure the Zenmuse X5 camera is set on AF mode when using the DJI Focus to control lens motor.
-

Settings

Enter Menu->Motor Para->Direction/Default

Direction: The direction for motor can be changed here. Under the 'Normal' setting, the lens rotates in the same direction of the motor control knob. Selecting 'Reverse', the rotate direction of lens and motor control knob will in reverse.

Default: Select 'Default Para' to restore the motor to default settings.

Upgrade

You can upgrade the firmware through the DJI PC/MAC Assistant.

Install DJI PC/MAC Assistant

a. Installing and Running on Windows

1. Download the DJI WIN DRIVER INSTALLER from the product page on DJI.com.
2. Download the appropriate Assistant installer from DJI.com.
3. Double click the Assistant installer and follow the steps to finish the installation, then launch the Assistant.

 The Assistant installer can be used on Windows XP, Win7, and Win8 (32 or 64 bit)

b. Installing and Running on Mac OS X

1. Download the Assistant installer (.DMG) from DJI.com, then Run the installer and follow the prompts to finish the installation.
2. When launching for the first time, if using Launchpad to run the Assistant, Launchpad will block access because Assistant has not been reviewed by the App Store. Locate the Gimbal icon using the Finder, press "Control," then click the icon (or right-click the icon using a mouse). Choose Open from the shortcut menu, then click Open in the dialog box to launch the program.
3. After the first successful launch, double click the Gimbal icon, as usual, to launch the program using the Finder or Launchpad.



DMG installer supports Mac OS X 10.9 or above.

Upgrade

You can view the latest firmware version information on this page.



Upgrade the firmware by following the steps below:

Upgrade the Controller

Turn off the controller and connect it to your computer via the Micro-USB cable and wait until the indicator LED in the Assistant blinks blue. Click "Upgrade" to upgrade the Follow Focus Remote and Follow Focus Remote Radio.

Upgrade the Motor

Turn on the controller, and connect to the motor through data cable, then connect the controller to your computer. Click "Upgrade" to upgrade the Follow Focus Motor and Follow Focus Motor Radio.

Force Upgrade

If you fail to upgrade, press and hold the bind button of the controller or motor, then release the bind button after powering on, now you can force upgrade.



1. Ensure that your computer is connected to the Internet.
2. Close any antivirus programs and network firewalls.
3. Ensure that the controller or the motor is powered on during the upgrade.
4. Do not disconnect the USB cable during the upgrade.

Specifications

General	
Operating Frequency	2.415-2.473 GHz
Max. Transmission Distance	100 m(out and unobstructed)
Transmitter Power	12 dBm
Operating Temperature Range	-20 to 55 °C
Motor	
Weight	170 g
Dimensions	90*50*26 mm
Max. Torque	0.35 Nm
Max. Speed	192 rpm
Working Current	Static current: 80 mA (@12 V) Stall current: 2.5A (@12 V)
Working Voltage	9-16 V
Noise	<25 dB(@96 rpm)
Rob Clamp Inner Diameter	19 mm or 15 mm
Gear	Teeth: 40, Module: 0.8
Controller	
Weight	745 g
Dimensions	153*86*90 mm
Battery	Model: FB01-554461 Type: LiPo Capacity: 1700 mAh,6.29 Wh Voltage: 3.7 V

FCC Warning Message

Any Changes or modifications not expressly approved by the party responsible for compliance could void the user's authority to operate the equipment.

This device complies with part 15 of the FCC Rules. Operation is subject to the following two conditions: (1) This device may not cause harmful interference, and (2) this device must accept any interference received, including interference that may cause undesired operation.

This equipment complies with FCC radiation exposure limits set forth for an uncontrolled environment. This transmitter must not be co-located or operating in conjunction with any other antenna or transmitter.

Note: This equipment has been tested and found to comply with the limits for a Class B digital device, pursuant to part 15 of the FCC Rules. These limits are designed to provide reasonable protection against harmful interference in a residential installation. This equipment generates uses and can radiate radio frequency energy and, if not installed and used in accordance with the instructions, may cause harmful interference to radio communications. However, there is no guarantee that interference will not occur in a particular installation. If this equipment does cause harmful interference to radio or television reception, which can be determined by turning the equipment off and on, the user is encouraged to try to correct the interference by one or more of the following measures:

- Reorient or relocate the receiving antenna.
- Increase the separation between the equipment and receiver.
- Connect the equipment into an outlet on a circuit different from that to which the receiver is connected.
- Consult the dealer or an experienced radio/TV technician for help.

IC RSS warning

This device complies with Industry Canada licence-exempt RSS standard (s). Operation is subject to the following two conditions: (1) this device may not cause interference, and (2) this device must accept any interference, including interference that may cause undesired operation of the device.

Le présent appareil est conforme aux CNR d'Industrie Canada applicables aux appareils radio exempts de licence.

L'exploitation est autorisée aux deux conditions suivantes:

- (1) l'appareil ne doit pas produire de brouillage, et*
- (2) l'utilisateur de l'appareil doit accepter tout brouillage radioélectrique subi, même si le brouillage est susceptible d'en compromettre le fonctionnement.*

IC Radiation Exposure Statement:

This equipment complies with IC RF radiation exposure limits set forth for an uncontrolled environment. This transmitter must not be co-located or operating in conjunction with any other antenna or transmitter.

Any Changes or modifications not expressly approved by the party responsible for compliance could void the user's authority to operate the equipment.

KCC Warning Message

“해당무선설비는 운용 중 전파혼신 가능성이 있으므로 인명안전과 관련된 서비스는 할 수 없습니다.”

“해당 무선설비는 운용 중 전파혼신 가능성이 있음”

NCC Warning Message

低功率電波輻射性電機管理辦法

第十二條經型式認證合格之低功率射頻電機，非經許可，公司、商號或使用者均不得擅自變更頻率、加大功率或變更原設計之特性及功能。

第十四條低功率射頻電機之使用不得影響飛航安全及干擾合法通信；經發現有干擾現象時，應改善至無干擾時方得繼續使用。前項合法通信，指依電信法規定作業之無線電通信。低功率射頻電機須忍受合法通信或工業、科學及醫療用電波輻射性電機設備之干擾。