

## 5 Preparing the Remote Controller

The PHANTOM 2 VISION+ remote controller is a wireless communication device that uses the 5.8GHz frequency band. The link between the remote controller and aircraft is already established before delivery.

The remote controller default is set to Mode 2 and CE compliance before delivery. Both the operating mode and compliance version can be configured in PHANTOM RC Assistant Software. Please refer to <PHANTOM RC Assistant> and <Compliance Configuration> for details.

**Compliance Version:** The PHANTOM 2 VISION+ remote controller is compliant with CE and FCC (see the FCC ID) regulations.



**Operating Mode:** The remote controller is divided to Mode 1 and Mode 2 according to different channel mappings.

**Mode 1:** The left stick is mapped to throttle channel.

**Mode 2:** The right stick is mapped to throttle channel.



The range extender and mobile device holder is already mounted on the remote controller. Twist mobile device holder to face outwards and fix in position to prepare for mobile device installation.



It is recommended not to use oversized mobile devices (e.g. iPad), which cannot be placed into the Mobile Device Holder.

### 5.1 The Remote Controller

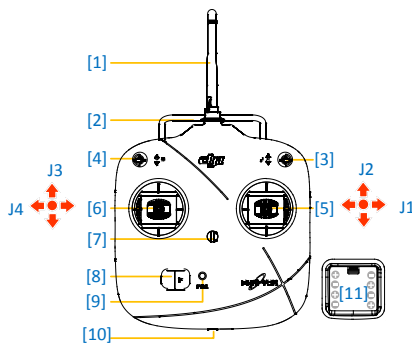

[1]	Antenna
[2]	Carrying Handle
[3]	Switch S1
[4]	Switch S2 (Reserved)
[5]	Joystick (J1: Roll [left&right], J2: Pitch [front&back])
[6]	Joystick (J3: Throttle [up&down], J4: Yaw [rotation])
[7]	Neck Strap Attachment
[8]	Power Switch
[9]	Power Indicator
[10]	RC Assistant Port (Micro-USB Port)
[11]	Battery Compartment (On the back)

### 5.2 Power on the Remote Controller

1. Install the four AA Batteries into the battery compartment on the back of the remote controller according to the negative and positive poles.
2. Set the S1 and S2 switches to the upper most position and all sticks at mid-point.

3. Toggle the power switch to right end to switch on the power.
4. There is a power on indicator beep. If the remote controller is set to be CE compliant, then there will be one beep while the FCCcompliant version will emit 2 beeps. The power indicator blinks greenquickly indicating the remote controller and receiver are binding. Once binding is completed, the power indicator will change to a solid green.

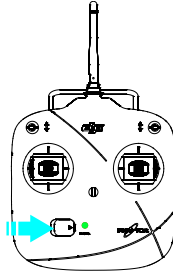

- (1) If the low voltage warning alert sounds(refer to the <Remote Controller Power Indicator Status Information>), please replace batteries as soon as possible.
- (2) For long term storage, be sure to remove the batteries from the remote controller.
- (3) Dispose the depleted batteries safely.



### 5.3 Remote Controller Power Indicator Status Information

Power indicator	Sound	Remote Controller State
	None	Functioning normally.
	None	Establishing a link between the remote controller and the receiver.
	B-B-B.....	Low voltage (at 3.9V-4.5V), should replace the batteries immediately.
	BBBB	Low voltage (lower than 3.9V). The remote controller will automatically power off. Replace the batteries immediately.
	B-B-B.....	The remote controllerwill give a visual indication of an alarm after 15 minutesof non-operation. The alarm status will go awayonce you start operating of the remote controller.



The remote controllerwill blink the LED and sound an alert when the voltage drops below3.9V and automatically power off after 3 seconds. This process will repeat even if you power cycle the remote controller. If this low voltage warning occurs during flight, the remote controllerwill automatically power off causing the aircraft to enter Failsafe mode which cannot be interrupted (refer to <Failsafe Function> section for details). It is strongly recommended to replace batteries immediatelyif the low voltage warning(3.9V-4.5V) occurs.

## 5.4 Antenna Orientation

Try to keep the antenna pointing skyward, perpendicular to the ground, in order to achieve the maximum communication range during flight.

The remote controller's antenna should be pointing skyward with no obstacles in the way. Otherwise, the failsafe function may initialize prematurely during flight. The Mobile Device and Range Extender should not block the antenna.

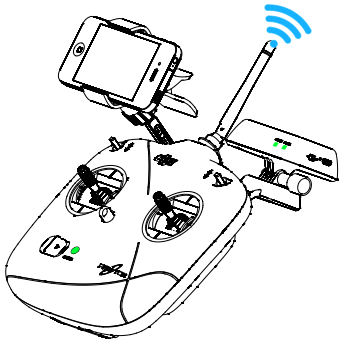
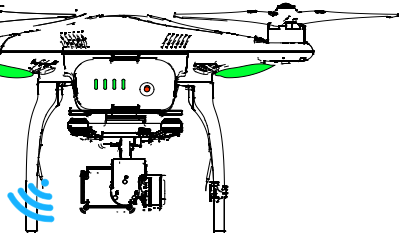

## 5.5 Remote Controller Operation







The remote controller default is set to Mode 2 before delivery, follow descriptions takes Mode 2 for example.

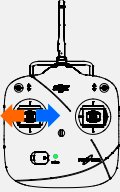
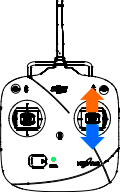
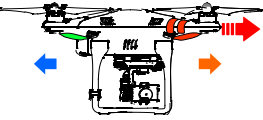
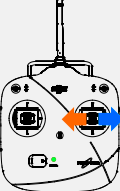

**Stick Neutral/ mid point:** Control sticks of the remote controller are placed at the central position.

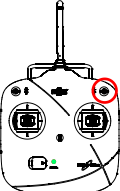
**Move the Stick:** The stick of remote controller is pushed away from the central position.

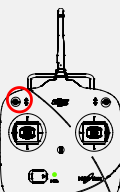
Remote Controller (Mode 2)	Aircraft ( ← nose direction )	Operation details
		<p>The throttle stick controls the aircraft elevation. Push the stick up and the aircraft will ascend. Pull the stick down and the aircraft will descend. The aircraft will automatically hover and hold its height when both sticks are centered. Push the throttle stick up beyond the centered (neutral) position to take off the aircraft. We suggest that you push the throttle stick gently to prevent the aircraft from sudden and unexpected elevation.</p>

		<p>The yaw stick controls the aircraft rudder.</p> <p>Push the stick left and the aircraft will rotate counter clock-wise.</p> <p>Push the stick right and the aircraft will rotate clock-wise. If the stick is centered, the aircraft will always fly in the same direction.</p> <p>The command stick controls the rotating angular velocity of the aircraft. Increasing movement of the command stick results in faster aircraft rotation velocity.</p>
		<p>The pitch stick controls the aircraft's front &amp; back pitch.</p> <p>Push the stick up and the aircraft will pitch and fly forward.</p> <p>Pull the stick down and the aircraft will pitch and fly backward. The aircraft will keep level and straight if the stick is centered.</p> <p>Increasing movement of the command stick will result in a larger pitch angle (maximum is 35°) and faster flight velocity.</p>
		<p>The roll stick controls the aircraft left &amp; right pitch.</p> <p>Push the stick left and the aircraft will pitch and fly left. Push the stick right and the aircraft will pitch and fly right. The aircraft will keep level and straight if the stick is centered.</p> <p>Increasing movement of the command stick will result in a larger pitch angle (maximum is 35°) and faster flight velocity.</p>
	 <p>Position-1 Position-2 Position-3</p>	<p>S1 is for compass calibration. Toggle the S1 from position-1 to position-3 and back to position-1 about 6 to 10 times which will force the aircraft to enter into compass calibration mode.</p> <p>In Naza-M mode, the S1 switch is used to switch control mode and compass calibration.</p>
	 <p>Position-1 Position-2 Position-3</p>	<p>S2 is used to record Home point manually. After a Home point is automatically recorded, quickly flipping the S2 switch of the remote controller from upper most to lower most positions 5 times or more will reset the current aircraft position as a new home point of PHANTOM 2 VISION+.</p> <p>In Naza-M mode, S2 is involved in IOC function.</p>



(1) For 'Ready to Fly' the aircraft will hover (hold a stable horizontal position) when all sticks are released.

- (2) For 'Ready to Fly (non-GPS)' the aircraft will keep the aircraft level without horizontal positioning when all sticks are released.

## 5.6 Link between the Remote Controller and Receiver

A 5.8G receiver is built-in PHANTOM 2 VISION+, its link button and indicator located on the bottom of the aircraft as illustrated in the following diagram.

The link between the remote controller and receiver is already established before delivery. Only re-establish the link when you try to replace the old remote controller or receiver with a new one.

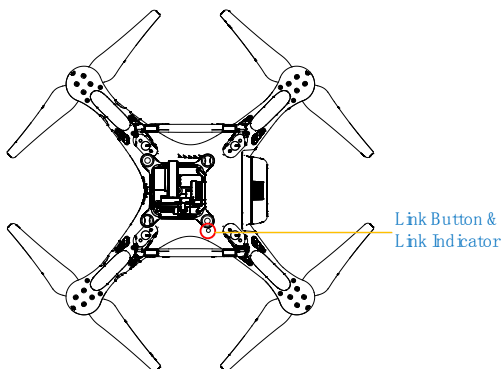

### Link Procedures

1. Power off the remote controller, power on the aircraft. You will see the link indicator blinking red.
2. Press the link button with a thin object and hold until the link indicator blinks yellow. Release the link button.
3. Power on the remote controller and the link indicator should switch off. This indicates that the link has been successfully established.

### Link Indicator

Link Indicator	Description	Next Operation
● ● ● ● ●	No signal received.	Switch on the remote controller or perform a link procedure.
● ● ● ● ●	In link status.	Switch on the remote controller.

## 5.7 Compliance Version Configuration

The compliance version can be reconfigured by twisting the potentiometer knob (See the following diagram) on the back of the remote controller using a flathead screwdriver. For CE compliance, set the remote controller to CE compliance by carefully turning the potentiometer knob to the full counter clock-wise position. For FCC compliance, set the remote controller to FCC compliance by carefully turning the potentiometer knob to the full clock-wise

position. Users should follow their local regulations accordingly.

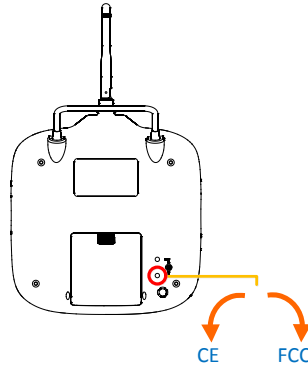

- (1) When adjusting the potentiometer knob to its limit position, be very careful to prevent damaging the potentiometer knob. Do not apply too much force during this adjustment. Also be sure to use the correct sized screwdriver.
- (2) CE compliant devices have an effective communication range of 300 meters in open spaces due to power limitations. Be sure to watch your flight distance as the PHANTOM 2 VISION+ will enter Failsafe mode (auto-landing or go home and land) if it flies beyond this range.
- (3) FCC compliant devices have an effective range of 500 meters in open spaces. Be sure to watch your flight distance as the PHANTOM 2 VISION+ will enter Failsafe mode (auto-landing or go home and land) if it flies beyond this range.
- (4) Pay attention to and follow local laws and regulations.



- (1) The remote controller comes set for CE compliance up delivery as the default setting.
- (2) It is recommended to use a flathead screwdriver of  $\Phi 2.4\text{mm}$  for adjustment.
- (3) There is another potentiometer reserved.



## 6 Preparing the Range Extender

The PHANTOM 2 VISION+ range extender is a wireless communication device that operates within the 2.4 GHz frequency band and is used for extending the effective range of communication between a mobile device (Smartphone) and the PHANTOM 2 VISION+. In an open unobstructed area, the transmission distance can reach up to 500 meters, but is usually affected by the surrounding environment, such as trees, buildings and other sources of the same frequency. Before every flight, it is suggested that you ensure the range extender functions properly. Otherwise you may experience a communication issue with the mobile device and the PHANTOM 2 VISION+.

Each range extender has a unique MAC address and network name (SSID), details of which are printed on the label as 'Phantom\_XXXXXX'. The 'XXXXXX' represents the last 6 letters or numbers of the MAC address for the range extender, users can rename the "XXXXXX" part in DJI VISION App.

### 6.1 The Range Extender

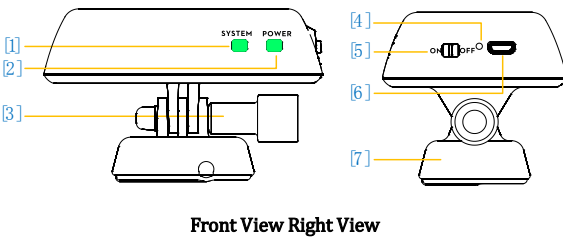

[1]	SYSTEM Indicator
[2]	POWER Indicator
[3]	Lock-screw
[4]	Reset Button
[5]	Power Switch
[6]	Charging Port(Micro-USB port)
[7]	Mounting Bracket

#### SYSTEM Indicator

Tells you the Wi-Fi status of range extender.

SYSTEM Indicator	Description
● ● ● ●	The Wi-Fi network is functioning normally.
Off	The Wi-Fi network is functioning abnormally.

#### Power Indicator (POWER)

Tells you the power status of range extender.

POWER Indicator	Description
■	The range extender is working normally or completely charged.
■	Low voltage alert, a re-charge is required.
■	The range extender is charging



If the power indicator is a solid red light, the ranger extender may stop working at any moment. Recharge it as soon as possible.

### Reset Button

Every time press the reset button once will reset the range extender, and the range extender will restart. Users have to bind the range extender with a PHANTOM 2 VISION+ again to rebuild a Wi-Fi network; otherwise the DJI VISION App will be failed to connect.

## 6.2 Usage

### Charging the Range Extender

Charging the range extender by connecting the charging port of it to a power supply device (such as PC and Micro-USB charger) via a Micro-USB cable. Make sure to charge the range extender completely before using it for the first time. It takes 3~4 hours (depending on USB power output) to be fully charged.



Make sure the range extender has enough power battery before each use.

### Powering on the Range Extender

1. Toggle the power switch of range extender to ON position.
2. Wait for approximately 30 seconds. The Wi-Fi signal indicator should blink green indicating the range extender is communicating properly.
3. Keep the range extender facing the aircraft during flight for the best communication link.



It is advised that you power off the range extender after every flight to avoid discharging the battery.

### Battery capacity level display

In the main page of DJI VISION App, a progress bar will display the battery capacity level and SSID of current connecting range extender. The percentage of the progress indicates the percentage of current capacity level. The progress bar is green when the percentage is no less than 30%, and it's red when the percentage is less than 30%. When the progress bar turns red, please charge the range extender as soon as possible.





## Low battery capacity warning

During flight, when the range extender is low battery capacity, a warning will appear in the camera page of DJI VISION App.

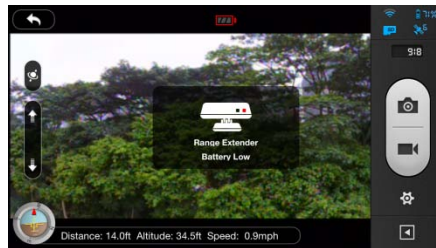

## 6.3 Rename SSID of Range Extender

For easier acknowledge the SSID of your range extender, users can rename SSID of range extender.



1. Tap "Rename SSID of Range Extender" in the Settings page. Enter a new name SSID name (e.g. Phantom\_2 VISION+) in the textbox.
2. Tap , and users will be asked to enter the last six numbers of MAC address on range extender to confirm the modification.
3. Tap "OK" to confirm and the range extenders should automatically restart. Approximately 30 seconds later, the network named of Phantom\_2 VISION PLUS can be searched in the Wi-Fi list of your mobile device. Select and connect the renamed network, DJI VISION App can be used.

## 6.4 Binding the Camera & Range Extender

If the connection of PHANTOM 2 VISION+ and range extender is lost, or one of them needs to be repaired or replaced, a camera and range extender binding will need to be performed via the DJI VISION App.

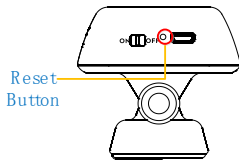

1. Power on the camera and range extender.
2. Approximately 30 seconds later, press the reset button on the range extender with a thin object until the SYSTEM Indicator turn off. The range extender will then restart automatically.
3. Approximately 30 seconds later, the SYSTEM Indicator should start to blink green, which indicates the range extender is now ready to be bound.
4. (Fig.1) Run the DJI VISION App->Settings->General->Binding. (Fig.2) Select 'Scan the QR Code' to scan the camera QR code on the product packaging. (Fig.3) Get the camera SSID (E.g. FC200\_0xxxxx) and the MAC address. Users can also skip the scan and enter the camera MAC address directly (Fig.4, Fig.5), the MAC address can be found on the label on camera.
5. Select the tick  on the top right corner. The range extender should automatically restart. The binding procedure is now completed.

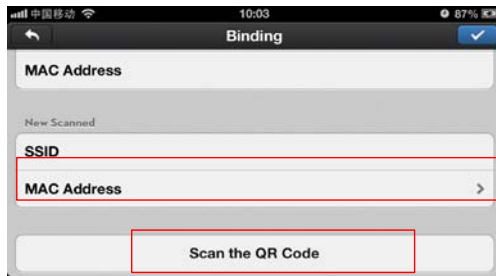

二维码示例

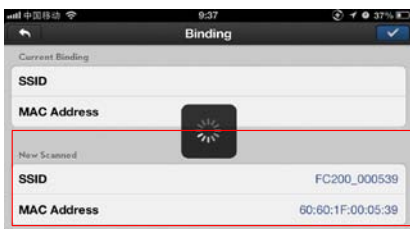

**⊘** DO NOT push the reset button of the range extender unless you are ready to rebind the range extender and the camera! This will unbind your camera and you must follow the steps above to rebind.

**⚠** If both the PHANTOM 2 VISION+ aircraft and range extender are powered on and working normally, you will be able to find the SSID on the Wi-Fi list of the mobile device.

**💡** (1) The QR code is located on the packaging of the PHANTOM 2 VISION+. If you cannot find the QR

code, please contact DJI customer service to receive the QR code related to your camera's serial number which is printed on the label of camera.

- (2) It's suggested to capture the QR code and reserved the picture in your mobile device or PC, in case of lost the QR code on the package.

# 7 Downloading and Installing the DJI VISION App

## 7.1 Download and Install

Download and install approaches		
Approach 1		Scan the QR code to get the download link. Download and install the DJI VISION App on your mobile device. You can find the QR code on the 'Quick Start Guide' as well as on the packaging of the PHANTOM 2 VISION+.
Approach 2	iOS user	Search "DJI VISION" from App Store, download and install on your mobile device.
	Android user	Search "DJI VISION" from Google Play, download and install on your mobile device.

Supported mobile devices	
iOS (iOS6.1 or above)	Recommended: iPhone4s, iPhone5, iPhone5s, iPhone5c, iPod Touch4, iPod Touch5; Available but not recommended: iPad3, iPad4, iPad mini, iPad Air.
Android (System 4.0 or above)	Samsung Galaxy S3, S4, Note2, Note3 or mobile devices of similar configuration.

 DJI continues to support many mobile devices and any information from users are welcome. Please send any questions or queries to the following mailbox: [phantom2vision@dji.com](mailto:phantom2vision@dji.com).

 Be aware that the DJI website regularly updates so make sure you visit often as well as the App Store or Google Play in order to download the latest version of the DJI VISION App.

## 7.2 Register & Login

 Access the Internet to register and login.

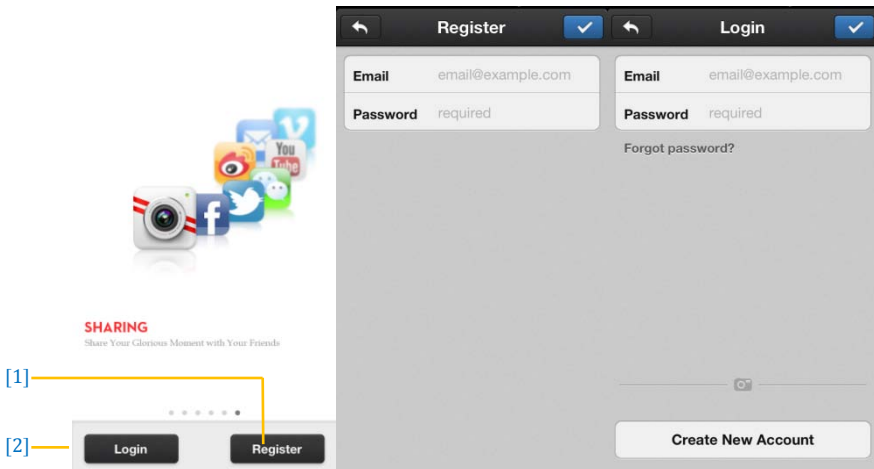

### [1] Register

Select 'Register' to enter the registration page. Fill in your Email and Password information and then tap 

to create a new account.



A DJI account is available for all DJI assistant software and app.

## [2] Login

Select 'Login' to enter the login page. Fill in your registered Email and Password and then tap  to login.



You should login to your account the first time you use the DJI VISION App.



If you do have an account, but forgot the password, select the "Forgot password" to retrieve it.

## [3] Usage tips

Useful tips will display when you enter the welcome page. Tap the screen to display the next useful tip.

[3]

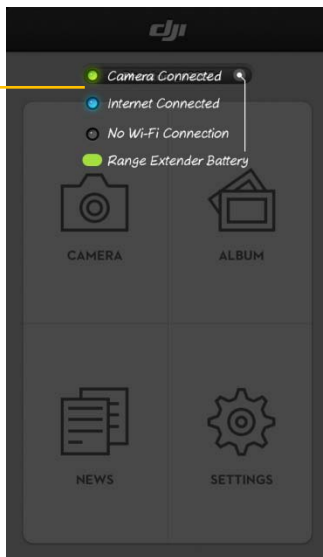

Enable "Tutorial" switch in Settings page, the usage tips will display as the first time you login the App, which can help you quickly acquire the usage of DJI VISION App.





## 8Connecting the Camera

It's important to using the mobile device connect the Wi-Fi network built by range extender and Wi-Fi module, the users can use DJI VISION App connect the camera and establish a live camera preview.

### 8.1 Connecting Procedures

Please carry out the following procedures to connect a mobile device to the camera of PHANTOM 2 VISION+.

1. Power on the remote controller and the range extender.
2. Turn on the power of PHANTOM 2 VISION+.
3. (Fig.1)Enable the Wi-Fi on your mobile device; wait for about 30 seconds, and then select "Phantom\_XXXXXX"from theWi-Fi network list.
4. (Fig.2)Run the DJI VISION App on your mobile device, current Wi-Fi connection status will be indicated on the main menu. The Wi-Fi connection indicatorturnssolid greenthatmeans the connection is good.
5. Tap the "CAMERA" icon and the DJI VISION Appwill establish a live camera preview (Fig.3). This means everything is now functioning.

Enable the Wi-Fi

Select Phantom\_XXXXXX

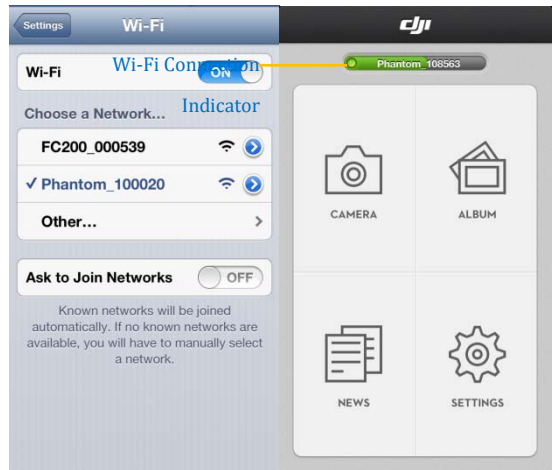





Fig.3

## Wi-Fi Connection Indicator Description

Icon		Description
	Solid green	Wi-Fi is now connected to the PHANTOM 2 VISION+.
	Solid blue	Wi-Fi is connected to another Wi-Fi network and NOT to the PHANTOM 2 VISION+.
	Off	No Wi-Fi connection.



- (1) The SSID is unique for each PHANTOM 2 VISION+ which should appear in your Wi-Fi list as Phantom\_XXXXXX.
- (2) Android users can tap the SSID button on the main page to enter Wi-Fi settings of the mobile device directly.



# Flight

After the installation is completed, it's recommended to take flight trainings refer to PHANTOM PILOT TRAINING GUIDE to enhance your flight skills or take adequate flight trainingsessions (such as running simulation or coaching by the experienced user) before you use the aircraft for the first time. Ensure that you have selected a proper location and environment for your flight.

## Flight Environment Requirement

- (1) Do not use the aircraft in the severe weather conditions, which include gale force winds (wind speed exceeds category 4), snowy, rainy and smog day.
- (2) Chose an open filed as the flight field, where no high building may block the flight route. Also the building with significant amount of steel structures may affect the accuracy of the compass on the aircraft.
- (3) Keep your aircraft away from any obstacles, crowds, high voltage power lines, trees or the surface of the water at all time when your aircraft is in the air.
- (4) To eliminate the electromagneticinterferences to the remote controller, ensure that your aircraft is not operating in the complex electromagnetic environment (such as staying close the base station or radio transmitting tower).
- (5) The aircraft cannot operate within the polar cycles.
- (6) Do not flight the aircraft in the no-fly zone specified by the local laws or regulations.

## 1 Calibrating the Compass

**IMPORTANT: Make sure to perform the Compass Calibration procedures prior to the first flight.** The compass is very sensitive to electromagnetic interferencewhich causes abnormal compass dataand leads topoorflight performance or even flight failure. Regular calibration of the compass enables the compass to perform at its optimal level.

- (1) DO NOT calibrate your compass where there is a possibility for the existence of strong magnetic interference such as magnetite, parking structures, and steel reinforcement underground.
- (2) DO NOT carry ferromagnetic materials with you during calibration such as keys or cellular phones

### 1.1 Calibration Procedures

Choose an open space to carry out the following procedures. Please watch the quick start video of the PHANTOM 2 VISION+for more details on the compass calibration.

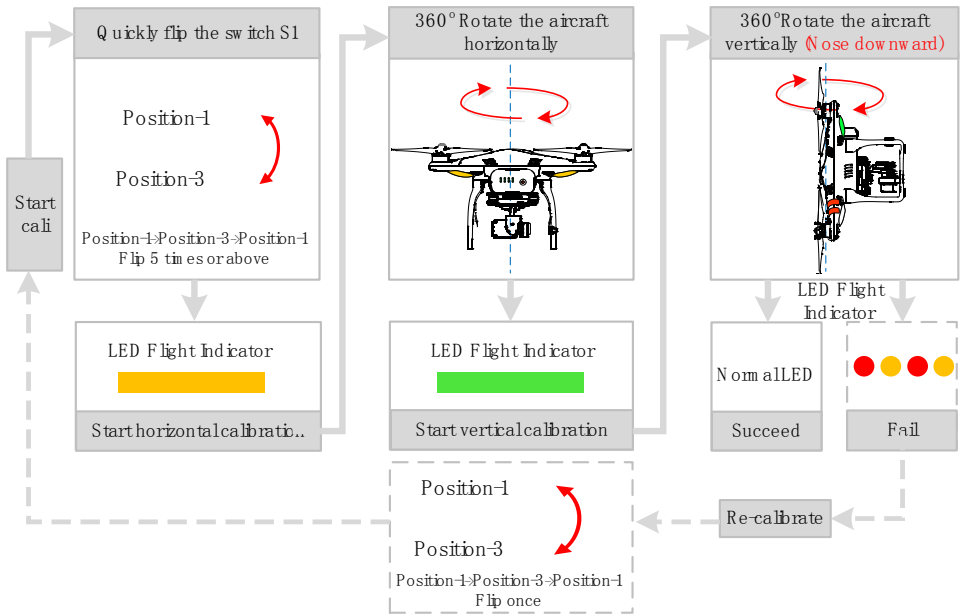

## 1.2 Recalibration Scenarios

- (1) When CompassData is abnormal, the LED flight indicator will blink alternating between red and yellow.
- (2) Last compass calibration was performed at a completely different flying field/location.
- (3) The mechanical structure of the aircraft has changed, i.e. changed mounting position of the compass.
- (4) Severe drifting occurs in flight, i.e. the aircraft does not fly in straight lines.

## 2 Starting the Motors

A Combination Stick Command (CSC) is used to start the motors instead of simply pushing the throttle stick up. Push both sticks to their bottom corners as indicated in the diagram below to start the motors. Once the motors have spun up, release both sticks simultaneously.

There are two methods to stop motors.

Method 1: Conduct CSC again and motors will stop immediately.

Method 2: When the aircraft has descended to the ground, push the throttle stick to its lowest position and hold, motors will stop 3 seconds later.

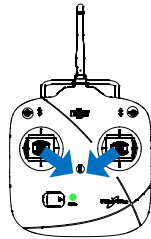

You **SHOULD NOT** execute the CSC during normal flight! This will stop the motors and cause the aircraft to descend rapidly and drop without any type of control.

## 3 Takeoff/Landing Procedures

1. Place the PHANTOM 2 VISION+ on an open flat ground with battery indicators are facing towards you.
2. Power on the remote controller and the range extender, then the intelligent battery.
3. Launch the DJI VISION APP and start the binding process between the mobile device and the PHANTOM 2 VISION+. After the binding is completed, enter the camera preview page.
4. Wait until the LED flight indicator starts to slowly blink green/yellow. This means the aircraft is initializing and entering the "Ready to Fly"/"Ready to Fly (non-GPS)." state. Then proceed to execute the CSC command to start motors.
5. Push the throttle stick up slowly to lift the aircraft off the ground. Refer to [<Remote Controller Operation Mode>](#) for more details.
6. Enjoy your flight while capturing and recording with the DJI VISION App. Refer to the [<DJI VISION App Usage>](#) for more details.
7. Be sure you are hovering over a level surface. Pull down on the throttle stick gently to descend and land.
8. After landing the aircraft on the ground, keep the throttle stick at its lowest position for about 3 to 5 seconds which will automatically stop the motors.
9. After landing the aircraft on the ground, keep the throttle stick at its lowest position for about 3 seconds which will automatically stop the motors.

- (1) When the LED flight indicator blinks yellow rapidly during flight, the aircraft has entered into Failsafe mode, refer to [<Failsafe Function>](#) for details.
- (2) A low battery capacity warning is indicated by the LED flight indicator blinking red slowly or rapidly during flight. Refer to the [<Low Battery Capacity Warning Function>](#) for details.
- (3) Watch the quick start video about flight for more flight information: [www.dji.com/phantom2visionplus/training](http://www.dji.com/phantom2visionplus/training).



## 4 Failsafe Function

The aircraft will enter Failsafe mode when the connection from the remote controller is lost. The flight control system will automatically control the aircraft to return to home and land to reduce injuries or damage.

**Home Point** When the aircraft enters into the “Ready to Fly” status from the “Ready to Fly status (non-GPS)”, the aircraft will record the current GPS coordinates as the home point.

- (1) When remote controller signal is lost, PHANTOM 2 VISION will use the recorded the home point coordinates as the home point for landing.
- (2) Home point coordinates will be used to calculate the horizontally distance of the aircraft (shown as “D” on the GUI of the DJI VISION app).
- (3) After successfully record the home point, you can see a fast blink of LED flight indicators on the aircraft.



### 4.1 Possible Failsafe Scenario

- (1) The remote controller is powered off.
- (2) The aircraft has flown out of the effective communication range of the remote controller.
- (3) There is an obstacle obstructing the signal between the remote controller and the aircraft, essentially reducing the distance the signal can travel.
- (4) There is interference causing a signal problem with the remote controller.

### 4.2 Failsafe Procedure

Initiating the Failsafe mode from different flying statuses will result in the different landing process. There are two types flying status that may affect the Failsafe landing process, one is “Ready to Fly” status and the other is “Ready to Fly (non-GPS)” status. The differences between these two statuses are shown as below:

#### **Ready to Fly (non-GPS) --- Automatic landing**

The flight control system will try to keep the aircraft level during descent and landing. Note that the aircraft may be drifting during descent and landing process.

#### **Ready to Fly --- Automatic go home and land**

The flight control system will automatically control the aircraft to fly back to the home point and land.

The figure below demonstrates the complete Failsafe landing process when the aircraft entered the Failsafe from the "Ready to Fly" status.

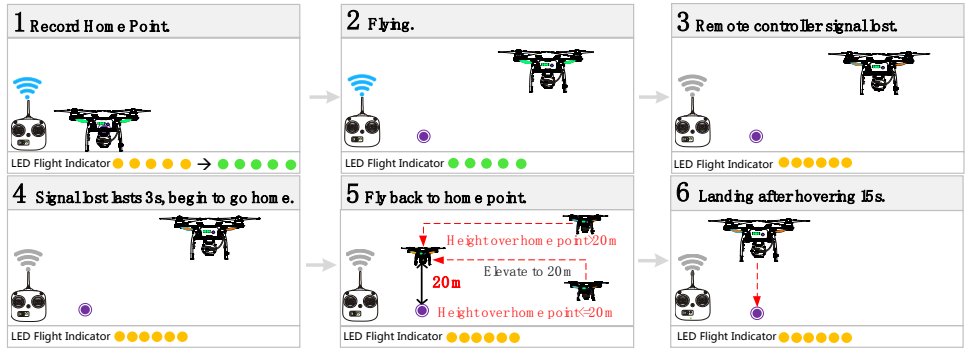

- 1) To ensure the aircraft can successfully return to the home point in the Failsafe mode after it lost the connection from the remote controller, only takeoff the aircraft when it is in the "Ready to Fly" status.
- 2) The aircraft will automatically descent during the Failsafe process, if there are less than 6 GPS satellites are detected for more than 20 seconds.
- 3) The aircraft cannot avoid obstacle during Failsafe.



Quickly flipping the S2 switch of the remote controller from upper most to lower most positions 5 times or more will reset the current aircraft position as a new home point of PHANTOM 2 VISION+.

### Failsafe on the DJI VISION App

The DJI VISION App will provide information during Failsafe.

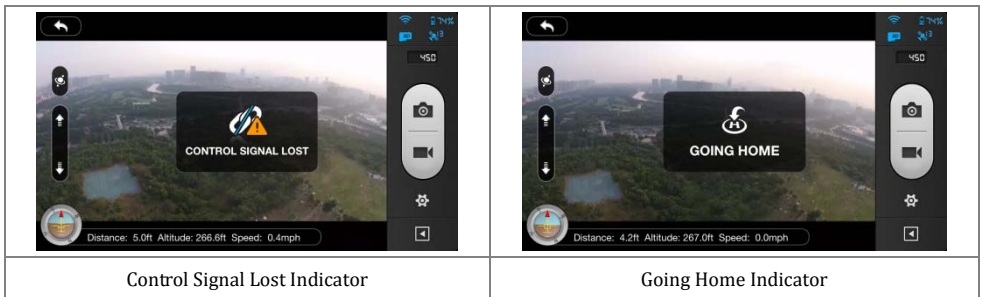

### 4.3 Regaining Control During Failsafe Procedure



	<b>Position-1</b>	<b>Position-2</b>	<b>Position-3</b>
How to regain control	When the S1 switch is switched to Position-1, toggle the S1 switch to any other position once to regain control. If remote controller's signal is recovered, control is returned back to the pilot.	Regain control as soon as signal is recovered.	

## 5 Low Battery Capacity Warning Function

The low battery capacity warning alerts users when the battery is close to depletion during flight. When it appears, users should promptly fly back and land to avoid accidental damage. The PHANTOM 2 VISION+ has two levels of low battery capacity warning. The default warning low battery threshold are 30% (first level warning) and 15% (second level warning) respectively.

### First Level Battery Low Warning

When battery level drops below 30%, the LED indicators will blink red slowly and the DJI VISION app will produce the alarm to notify the user. Refer to [<DJI VISION app Low Battery Capacity Warning>](#) for more information.

### Second Level Battery Low Warning

When the battery level drops below 15%, the LED indicators will blink red rapidly. At the meantime, the aircraft will gently descent to the ground. The PHANTOM 2 VISION+ will also begin to descend and land automatically. After it has landed, keep the throttle stick at its lowest point or execute CSC; refer to [<Starting the Motors>](#) for more information about how to execute the CSC. The other option is to push the throttle upward to hover the aircraft and navigate it to a more appropriate location for landing.



When battery low warning is triggered, you must bring the aircraft back to the home point to avoid losing the power for the aircraft.

### DJI VISION App Low Battery Capacity Warning

DJI VISION App will show low battery capacity warnings.

- (1) A red rectangle will blink on the camera screen.
- (2) Audible alarm. Make sure the sound is turned on and volume is turned up on your mobile device.
- (3) The aircraft battery icon will turn red.



Low Battery Capacity Warning





## DJI VISION App Usage

The DJI VISION App controls the PHANTOM 2 VISION+ camera including capture and recording, settings, pitch angle adjustments, and displays essential status including flight parameters and battery level.

### 1 DJI VISION App Main Menu

After login you can see the GUI as shown below. The GUI shows the current Wi-Fi connection status and four main features of the App.



Icons	Description	
	<b>Camera</b>	Tap to enter camera preview
	<b>Album</b>	Tap to enter Album
	<b>News</b>	Tap to enter DJI news
	<b>Settings</b>	Tap to enter App settings

- 1) When using the camera and the [SD card album](#), you need to connect your mobile device to the PHANTOM 2 VISION+ Wi-Fi network.



- 2) Access to internet is necessary (mobile or Wi-Fi) to share photos, videos and read DJI news.
- 3) **If you receive a phone call during flight, the live camera preview screen may be interrupted. It's recommended to ignore the call and pay full attention to your flight.**



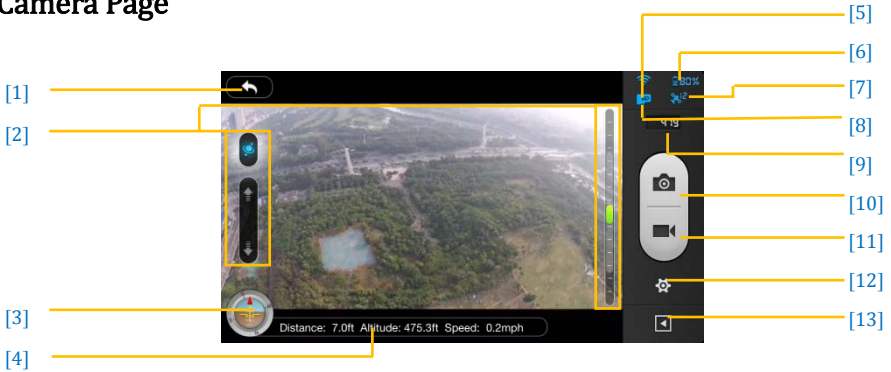

## 2 Camera Page





### [1] Return

 - Return to the preview page

### [2] Camera Pitch Control

 Pitch Control switch is white  when in normal mode, tap once the switch will be highlight  and enter into the Accelerometer Sensor Mode. Tap once again to return to normal mode.

#### Normal Mode

Tap up arrow  to pitch camera upwards and down arrow  to pitch downwards. Green slider  indicates current camera pitch.

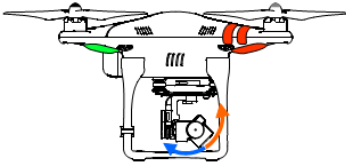
Gimbal pitch control (Normal Mode)	Gimbal pitch movement
	

#### Accelerometer Sensor Mode

Tap the camera pitch switch once to enter into Accelerometer Sensor Mode. The gimbal pitch movement and aircraft yaw movement will be controlled by moving your mobile device.



( 1 ) Hold your mobile device carefully in Accelerometer Sensor Mode as any movement of it will change the gimbal pitch angle and aircraft azimuth angle real timely.



( 2 ) Compared with the control of mobile device movement in Accelerometer Sensor Mode, the control of remote controller is prior.

1) Camera Pitch Angle Control

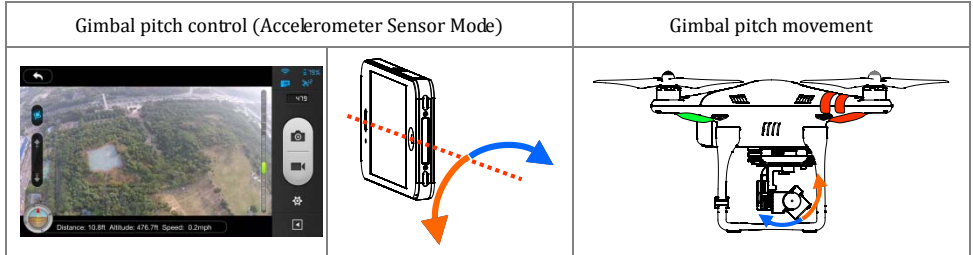
Pitch the mobile device forward to pitch down the camera. Pitch the mobile device inward to pitch up the camera.



2) Aircraft Yaw AxialControl

If you wish to use the mobile device to control the Yaw movement of the aircraft, you need to enable this function in the setting page of the DJI VISION App. After this function is enabled, Lean the mobile device left to rotate left  and right to rotate right .

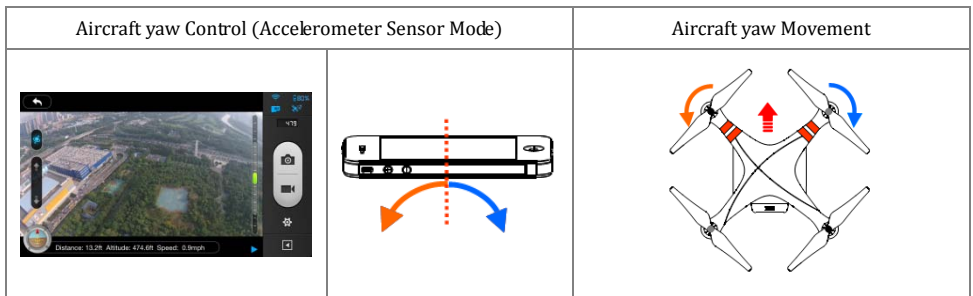

Yaw axial control can be enabled and disabled from the setting page of the DJI VISION App.



### [3] Flight Attitude and Radar Function

Flight attitude is indicated by the flight attitude icon.

- (1) The red arrow shows which direction the PHANTOM 2 VISION+ is facing.
- (2) Blue and brown areas indicate its pitch.
- (3) Pitching of the brown and blue area shows roll angle.



Tap the flight attitude icon to turn on the radar function. Home is located in the center of the radar and the red icon indicates the PHANTOM 2 VISION+'s current heading, direction, and approximate distance from home.

Tap the flight attitude icon again to disable the radar.



- \_\_\_\_\_ Aircraft
- \_\_\_\_\_ Mobile Device Location
- \_\_\_\_\_ Distance

- (1) By default, the center of the radar indicates the home point that has been recorded by the PHANTOM 2 VISION+. Tap the center of the radar to switch the center to your mobile device's current location.
- (2) If your mobile device contains a compass, the top portion of the Radar is the direction you are pointing. If not, the radar will be oriented due north.

### [4] Flight Parameters

Distance: Horizontal distance from home point.

Altitude: Vertical distance from home point.

Speed: Horizontal flying speed.





Distance value will show as N/A if the PHANTOM 2 VISION+ is not in "Ready to Fly" status.

## [5] Wi-Fi Signal Intensity

Indicates camera is connected to your mobile device and Wi-Fi is working normally.

The connection between the camera and mobile device may fail if Wi-Fi signal strength is low. Refer to the <PHANTOM 2 VISION+ CONNECTION BROKEN> for more information.

## [6] Aircraft Battery Level

- (1) When available power is more than 30%, the battery icon is blue (e.g. ). This battery level is appropriate for flight.
- (2) When below 30%, the battery icon will turn red (e.g. ) and the LED flight indicator will slowly blink red. This battery level is low for flight. It is recommended that fly the aircraft back and land it as soon as possible.
- (3) After available power drops below 15% (e.g. ) , there is no longer enough power for flight. The LED flight indicator will begin to flash red rapidly and the PHANTOM 2 VISION+ will begin an automatic descent and land.



The threshold for the first and second level batter low warning can be set in the PHANTOM 2 VISION+ Assistant Software.

## [7] Aircraft GPS Status

GPS status icon display the number of satellites searched by the aircraft. The icon is highlighted when more than 6 satellites are found that allow the aircraft to enter the "Ready to Fly" mode.

## [8] Micro-SD Card Status

Displays Micro-SD Card Status. The icon is highlighted when a valid Micro-SD card is inserted. If there is no Micro-SD card present, it is grayed out.

## [9] Remaining Shots

Displays estimated shots remaining, based on the current Photo Sizesetting of camera and the storage capacity of the Micro-SD card. This shows '0' if:

- (1) Micro-SD card is not inserted.
- (2) Micro-SD card is full.

(3) Micro-SD card is damaged.

(4) Connection between the DJI VISION App and camera is broken.

## [10] Shutter Button

Tap to take photos.

Single capture: press once for a single capture.

Continuous capture: press once for 3 or 5 captures.

Timed capture: press once to begin a timed capture, press again to stop.



- (1) Shutter button is disabled during video recording.
- (2) Capture modes can be reconfigured in camera settings; refer to the [<Camera Settings>](#).

## [11] Video Recording Button

Start and stop video recording. Tap once to start recording. Red dot will blink to indicate recording is in progress and a time code will appear in the top right corner of the preview screen. Press again to stop recording.

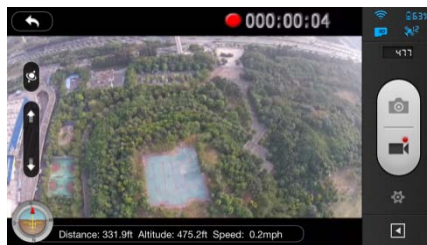

## [12] Camera Settings

Tap to open the camera settings menu, refer to [<Camera Settings>](#).

## [13] Hide or Show Flight Parameters.

Tap to hide the flight parameters. Tap again to show.

### 3 Camera Settings

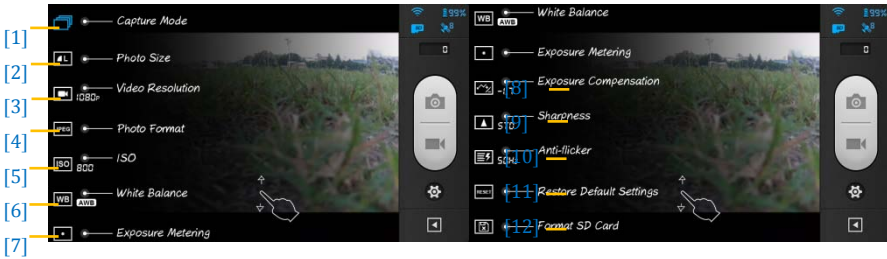

#### [1] Capture Mode

	Single capture.
	3 captures.
	5 captures.
	Timed capture. Also selectable:
	<ul style="list-style-type: none"> <li>a) Intervals between two shots (3~60 s)</li> <li>b) Number of shots (2~254, or number of picture is subject to the capacity of the memory card)</li> </ul>



Capture Button will change according to the selected capture mode , , , .

#### [2] Photo Size

	Large: 4384 x 3288, 4:3, 14.4MP
	Medium: 4384 x 2922, 3:2, 12.8MP
	Small: 4384 x 2466, 16:9, 10.8MP

#### [3] Video Resolution

	1920x1080 60i, 16:9
	1920x1080 30p, 16:9
	1920x1080 25p, 16:9
	1280x960 30p, 4:3
	1280x960 25p, 4:3
	1280x720 60p, 16:9
	1280x720 30p, 16:9
	640x480 30p, 4:3 (VGA)