

WIND-4

Customized Flying Platform

User Manual

V1.1

2017.06.15

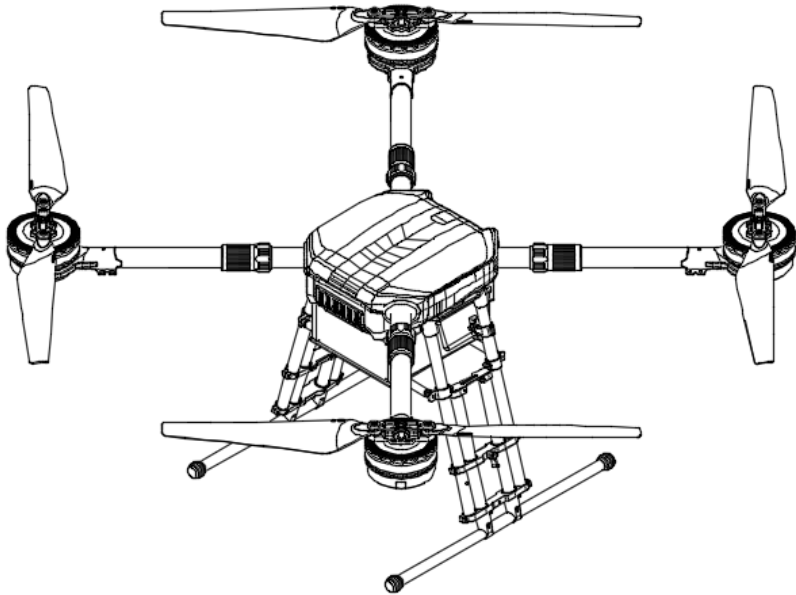

Searching for Keywords

Search for keywords such as “battery” and “install” to find a topic. If you are using Adobe Acrobat Reader to read this document, press Ctrl+F on Windows or Command+F on Mac to begin a search.

Navigating to a Topic

View a complete list of topics in the table of contents. Click on a topic to navigate to that section.

Printing This Document

This document supports high resolution printing.

Information

The WIND-4 **customized** flying platform is a professional flying platform. Read the User Manual and take necessary precautions when handling the WIND-4 to ensure your own safety. DJI assumes no liability for damage or injuries incurred directly or indirectly from using the WIND-4 improperly.

Using This Manual

Legends

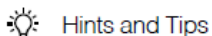
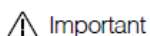
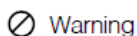

Before Flight

The following tutorials and manuals have been produced to help you get the most out of your WIND-4.

1. WIND-4 Disclaimer and Safety Guidelines
2. WIND-4 User Manual
3. WIND-4 Intelligent Flight Battery Safety Guidelines

We recommend that you read the *WIND-4 User Manual*, *WIND-4 Disclaimer and Safety Guidelines* and *WIND-4 Intelligent Flight Battery Safety Guidelines* carefully before flight.

Download the DJI GO App

Download and install the DJI GO app before use. Scan the QR code or visit <http://m.dji.net/djigo> to download the app.

DJI GO supports iOS 8.0 (or later) or Android 4.1.2 (or later).



Warnings

The WIND-4 may cause serious damage and injury. The WIND-4 is not suitable for children under the age of 18 or non-professionals.

Assembly Warnings

1. Ensure that the Intelligent Flight Batteries are fully charged and properly inserted before power-on.
2. Calibrate the compass before flight and confirm the Stick Mode.
3. Ensure that propellers are **unfolded** before unlocking the motors.

Environmental Considerations

1. Flying under 9,843 feet (3000 m) above sea level.
2. Fly in moderate weather conditions with temperatures between -10°C to +40°C (14°F to 104°F).
3. DO NOT fly in No Fly Zones.
4. Visit the following link to learn about No Fly Zones: <http://www.dji.com/cn/fly-safe/category-mc>
5. Maintain a safe distance from obstacles, people, high voltage power lines, tall trees and other hazards when flying the aircraft.
6. Ensure that the aircraft is visible at all times.

Flight Warnings

1. The aircraft is resistant to water. Please fly it carefully in rainy or snowy days.
2. Ensure that all parts are in good condition before each flight. DO NOT fly with worn or damaged parts.
3. Ensure that the propellers and motors are installed correctly and propellers and frame arms are unfolded before each flight.
4. Ensure that the DZ-12000 Intelligent Flight Battery for the WIND-4 is used.
5. Consult the dedicated technician before mounting third-party devices to the aircraft. DO NOT overload the system.
6. DO NOT go near or touch the motors or propellers when they are spinning, as this can cause serious injury.
7. Disconnect the batteries during transportation to avoid damage or injury to the landing gears.
8. DO NOT stop the motors mid-flight.
9. DO NOT answer incoming calls during flight or fly under the influence of alcohol or drugs within eight hours.
10. In the instance of a Low Battery Warning, land the aircraft at a safe location.
11. Power off the aircraft and then turn off the remote controller after landing.
12. Only use compatible DJI parts.

Contents

Information.....	1
Using This Manual.....	1
Legends	1
Before Flight	1
Download the DJI GO App	1
Warnings.....	2
Assembly Warnings.....	2
Environmental Considerations.....	2
Flight Warnings	2
Contents.....	4
Product Profile.....	6
Introduction.....	6
Quick Installation	7
Intelligent Flight Battery	10
Profile	10
Intelligent Flight Battery Functions	10
Using the Battery	11
Remote Controller.....	14
Remote Controller Profile	14
Preparing the Remote Controller	14
Remote Controller	15
Remote Controller Operations.....	16
Remote Controller Status LED	22
Linking the Remote Controller With the Aircraft.....	23
Remote Controller Compliance Version	24
Flight.....	29
Operation Environment Requirements	29
Flight Limits and No Fly Zones.....	29
Maximum Height and Radius Limits	30
Preflight Checklist.....	26
Flight Status Indicator	26
Calibrating the Compass	27

Starting and Stopping the Motors	30
Flight Test	30
Appendix.....	30
Specifications	30

Product Profile

Introduction

The WIND-4 is a professional flying platform. It is equipped with DJI's industry-leading flight controller system, E5000 propulsion system, and Lightbridge 2 transmission system. The WIND-4 is fully compatible with supply box, megaphone etc., allowing developers to optimize the flying platform for specific applications.

Aircraft

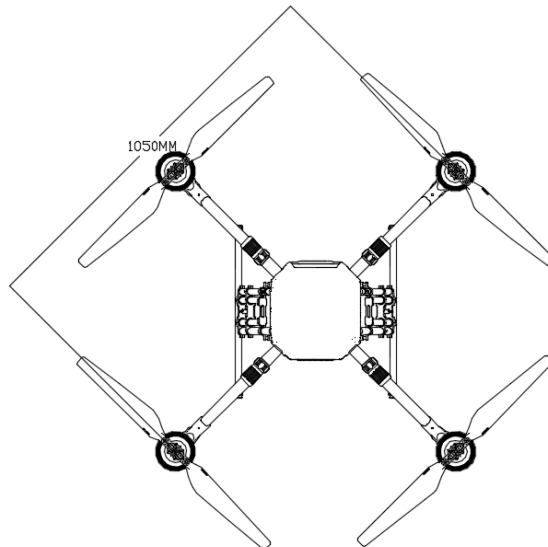
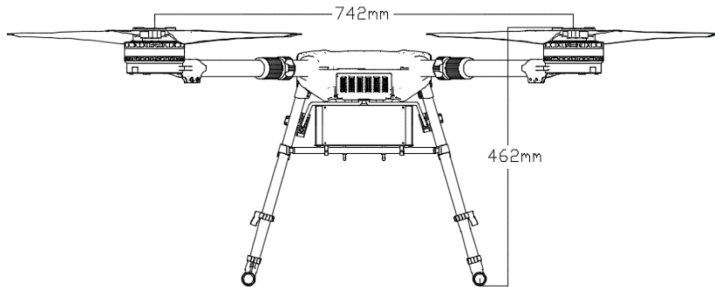

Quick Installation

Unfold the frame arms one by one, as shown in the figure below.

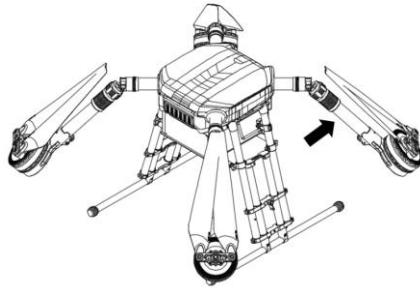

Gently hold the motors from their bottoms with hands, rotate the arm sleeves clockwise, and ensure that they are tightened firmly.

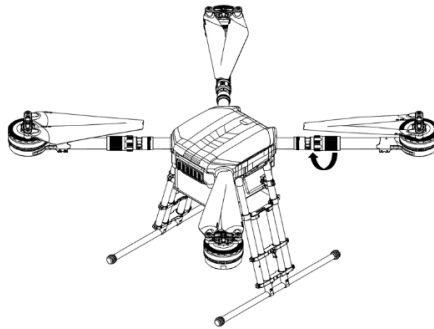

If necessary, lengthen the landing gears by operating the following steps:

1. Loosen the screws on the landing gears counterclockwise.

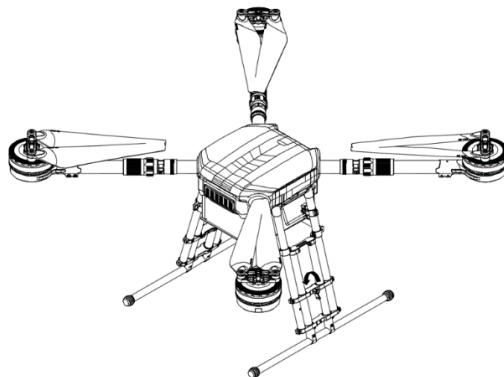

2. Stretch the landing gears to the required positions.

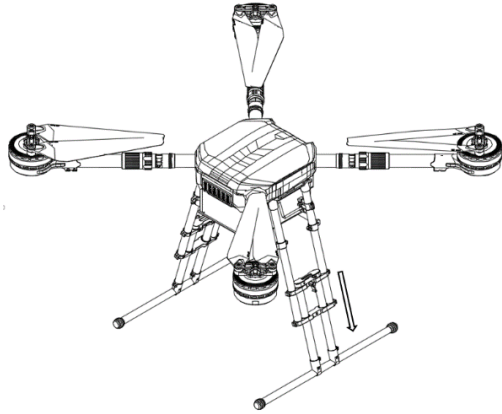

3. Tighten the screws on the landing gears counterclockwise.

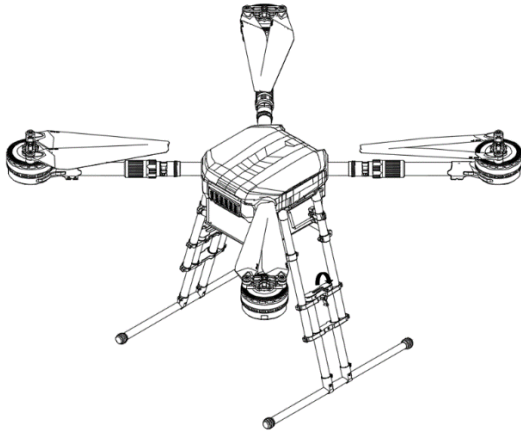

Installing the Intelligent Flight Battery

Insert the Intelligent Flight Batteries into the battery compartments.

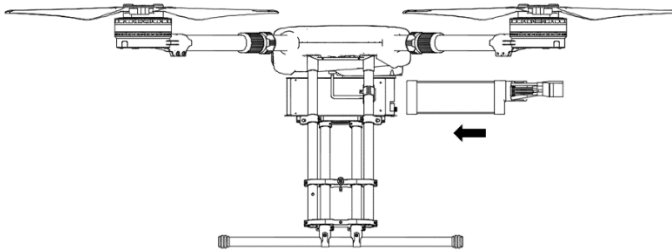

Connecting the Power Connectors

Connect the right connector and then the left connector at one time.

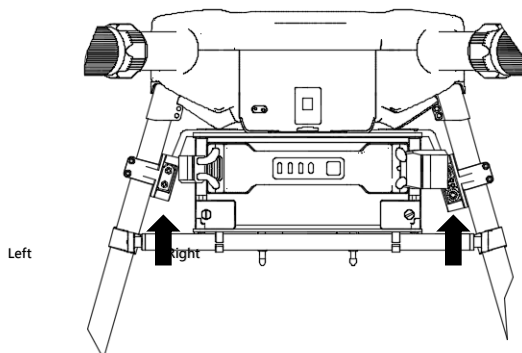

 Ensure that the two connectors are disconnected before inserting the battery in to or removing it from the WIND-4. DO NOT insert or remove the battery when powered on.

Intelligent Flight Battery

Profile

The Intelligent Flight Battery has a capacity of 12000 mAh, a voltage of 44.4 V, and smart charge/discharge functionality. It includes brand new battery cells and an advanced battery management system. It should only be charged using a DJI approved charger.

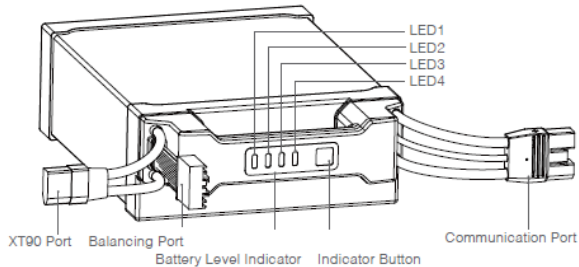

⚠ Ensure that the Intelligent Flight Battery does not have cosmetic damage or is not swollen before use. It must be fully charged before use.

Intelligent Flight Battery Functions

DJI Intelligent Flight Battery's functions are listed below:

1. Battery Level Display: LEDs display the current battery level.
2. Battery Life Display: LEDs display the current battery life.
3. Communication: The aircraft can obtain the real-time battery information such as voltage, charge, and current via the power supply and communication port on the battery.
4. Auto Start: The battery will start when being connected with the aircraft.
Sleep Mode: The battery will enter sleep mode when it is powered on and not connected to the aircraft for 20 minutes to save power.
5. Battery Error History: Display the latest 31 battery errors, such as a battery short circuit, overcurrent during discharging, etc.
 - A. Over Charge Protection: Charging automatically stops when the battery is fully charged.
 - B. Temperature Detection: The battery will only charge when the temperature falls between 5°C (41°F) and 40°C (104°F).
 - C. Over Current Protection: Battery stops charging when high amperage (more than 25A) is detected.
 - D. Over Discharge Protection: Discharging automatically stops when the battery voltage reaches 38.4 V to prevent over-discharge damage.

6. Auto-discharging: The battery automatically discharges to below 65% of total charge when it is idle for more than 10 days to prevent swelling. It takes around 2 days to discharge the battery to 65%. It is normal to feel moderate heat emitting from the battery during the discharge process. Discharge thresholds can be set in the DJI GO app.
7. Balanced Charging: Automatically balances the voltage of each battery cell when charging.
8. Short Circuit Protection: Automatically cuts the power supply when a short circuit is detected.
9. Battery Cell Damage Protection: The DJI GO app shows a warning message when a damaged battery cell is detected.
10. Battery Error History: Browse the battery error history from the DJI GO app.

Using the Battery

Powering On/Off

Powering On: Press the Power Button once, then press and hold it for 2 seconds to power on. The Power LED will turn red and the Battery Level Indicators will display the current battery level.

Powering Off: Press the Power Button once, then press and hold it for 2 seconds to power off.

Low Temperature Notice

1. Using the Intelligent Flight Battery at core temperatures below -10°C (14°F) is not advised. Between -10°C (14°F) and 5°C (41°F), the Intelligent Flight Battery should attain a voltage of 4.2 V, but it is recommended applying the insulation sticker to the battery to avoid a rapid drop in temperature.
2. In cold environments (i.e. air temperature below 5°C (41°F)), the performance of the Intelligent Flight Battery is reduced. Ensure the Intelligent Flight Battery is fully charged and attains a voltage of 4.35 V before takeoff.
3. In very cold environments (e.g. air temperature of -20°C (-4°F), battery core temperature of 5°C (41°F)), the Intelligent Flight Battery's core temperature will drop rapidly even after pre-heating, and its performance is significantly reduced. It is not recommended to fly under such conditions.
4. If the DJI GO app displays the Low Battery Level warning, stop flying and land the aircraft immediately. You will still be able to control the aircraft's movement when this warning is triggered.
5. To ensure the optimal performance, maintain the Intelligent Flight Battery's core temperature above 20°C (68°F) in use.







Ensure the temperature of the Intelligent Flight Battery exceeds 5°C (41°F) before takeoff.

































To warm up the battery, power on the Intelligent Flight Battery inside the battery compartment for approximately 1-2 minutes before takeoff. Begin flying by hovering the aircraft at a low altitude (for approximately 1 minutes) to ensure an appropriate battery temperature is reached.

Checking the Battery Level

The Battery Level Indicators display how much remaining charge the battery has. When the battery is powered off, press the Power Button once. The Battery Level Indicators will light up to display the current battery level.

































 The Battery Level Indicators will also show the current battery level during charging and discharging. The indicators are defined below.

 The LED is on.  The LED is flashing.  The LED is off.

Battery Level				
LED1	LED2	LED3	LED4	Battery Level
				88% - 100%
				75% - 87%
				63% - 74%
				50% - 62%
				38% - 49%
				25% - 37%
				13% - 24%
				0% -12%

Battery Life

The battery life indicates how many more times the battery can be discharged and recharged before it must be replaced. When the battery is powered off, press and hold the Power Button for 5 seconds to check the battery life. The Battery Level Indicators will light up and/or blink as described below for 2 seconds:

Battery Life				
LED1	LED2	LED3	LED4	Battery Life
				100%
				95%-99%
				90%-94%
				85%-89%
				80%-84%
				75%-79%
				70%-74%
				below 70%

 When the battery life is shown as 0%, it can no longer be used.

 For more information about the battery, launch DJI GO and check the information under the battery tab.

Charging

1. It is recommended to charge a battery at 1C (12 A). (DO NOT charge a battery beyond 2C.) Never leave the battery unattended during charging. Never drop the battery into water or let it come into contact with water.
 2. Open the Protection Cap and connect the Intelligent Flight Battery to the Battery Charger. If the battery level is above 95%, turn on the battery before charging.
 3. Air-cool the Intelligent Flight Battery after each flight. Allow its temperature to drop to room temperature before storing it for an extended period.
-

 The charger can charge at most two sets of batteries at one time.

The charging temperature ranges from 0°C to +40°C (32°F to 104°F). The battery management system will stop the battery from charging when the battery cell temperature is out of range.

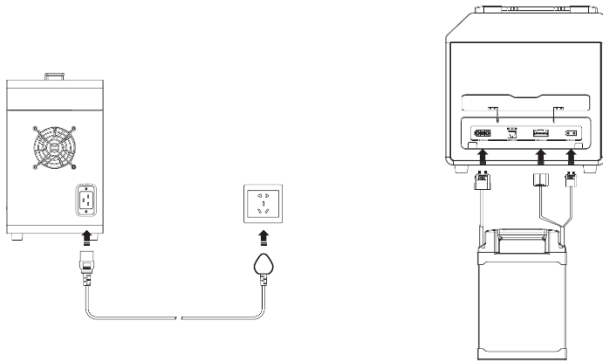



















Figure-1 Battery Connection

Battery Level Indicators while Charging				
LED1	LED2	LED3	LED4	Battery Level
				0%-24%
				25%-49%
				50%-99%
				100%

 DJI does not take any responsibility for damage caused by third-party chargers.

Remote Controller

Remote Controller Profile

The remote controller operates at 2.4 GHz with a maximum signal transmission range of 3 km.

 **Compliance Version:** The remote controller complies with both CE and FCC regulations (refer to FCC ID).

Operating Mode can be set to Mode 1, Mode 2 or a custom mode.

Mode 2: The left stick serves as the throttle.

Mode 1: The right stick serves as the throttle.

 To prevent transmission interference, do not operate more than three aircraft in the same area.

Preparing the Remote Controller

Tilt the Mobile Device Holder to the desired position, adjust the antenna, and connect the mobile device as shown.

1. Press the button on the side of the Mobile Device Holder to release the clamp.
2. Place your mobile device inside the clamp and adjust the clamp to secure your mobile device.
3. Connect your mobile device to the remote controller via a USB cable.

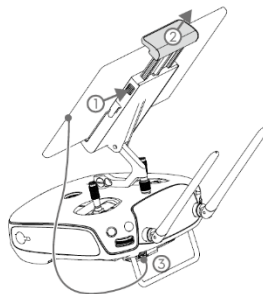
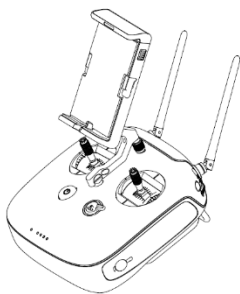

Remote Controller

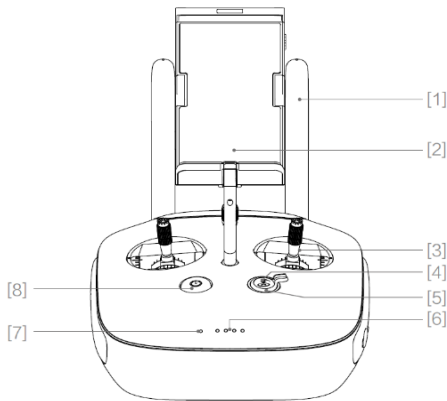

- [1] Antenna
Relays aircraft control and video signal.
- [2] Mobile Device Holder
Securely mounts your mobile device to the

remote controller

- [3] Control Stick
Controls the aircraft's orientation.
- [4] Return-to-Home (RTH) Button
Press and hold the button to initiate Return-to-Home (RTH).
- [5] RTH LED
A circular LED around the RTH button that displays RTH status.
- [6] Battery Level LEDs
Displays the battery level of the Remote Controller.
- [7] Status LED
Displays the Remote Controller's system status.
- [8] Power Button
Used to turn the Remote Controller on and off.

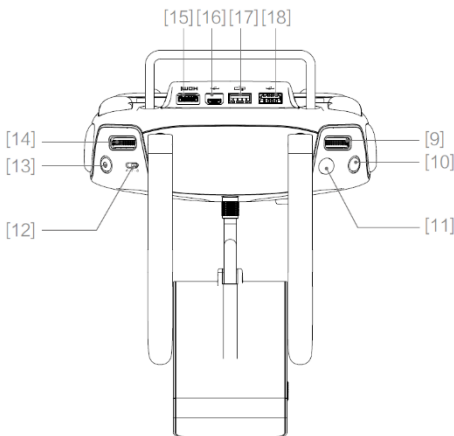

- [9] Camera Settings Dial
Turn the dial to adjust camera settings. (Only functions when the remote controller is connected to a mobile device running the DJI GO

- app.)
- [10] Playback Button
Plays the captured images or videos again.
- [11] Shutter Button
Press it to take a photo. In burst mode, a set number of photos will be taken with one press.
- [12] Flight Mode Switch
Used to switch between P-mode, A-mode and F-mode.
- [13] Video Recording Button
Press to start recording a video. Press again to stop recording.
- [14] Gimbal Dial
Use this dial to control the tilt or pan of the gimbal.
- [15] Mini-HDMI Mini HDMI Port

Connects to an HDMI monitor.

[16] Micro USB Port

Reserved

[17] CAN Port

Reserved

[18] USB Port

Connects to your mobile device to run the DJI GO app.

Used to pinpoint the location of the remote controller.

[20] Button C1

[21] Power Port

Connects to a power source to charge the remote controller's internal battery.

[22] Button C2

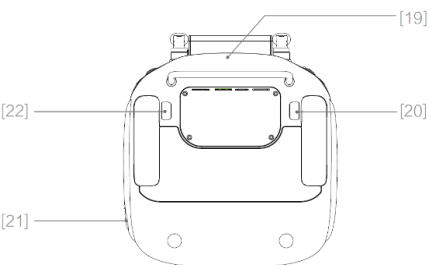

[19] GPS Module

Remote Controller Operations

Powering On and Off the Remote Controller

The Wind-4 remote controller is powered by a 2S rechargeable battery with a capacity of 6000 mAh. The battery level is indicated by the Battery Level LEDs on the front panel. When the remote controller is turned off, press the Power Button once and the Battery Level LEDs will display the current battery level. If the battery level is low, charge the remote controller.

Follow the steps below to power on your remote controller:

1. Press and hold the Power Button for two seconds to power on the remote controller.
2. The remote controller will beep when it is turned on. The Status LED will rapidly flash green, indicating that the remote controller is linking to the aircraft. The Status LED will be solid green when the linking is complete.
3. Repeat step 1 to turn off the remote controller.

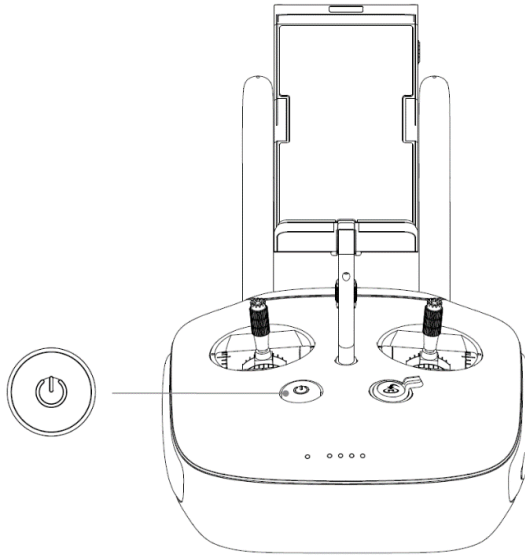

Charging the Remote Controller

Charge the remote controller using the included charger.

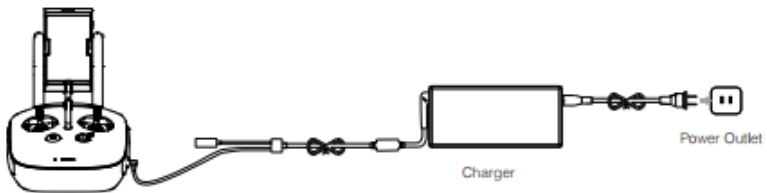







Controlling the Aircraft

This section explains how to control the orientation of the aircraft through the remote controller. The remote controller is set to Mode 2 by default.

 **Stick Neutral/Mid-Point:** Control sticks are in the center position.

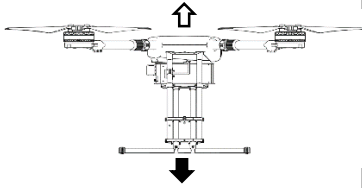
Moving the Control Stick: The control stick is pushed away from the center position.

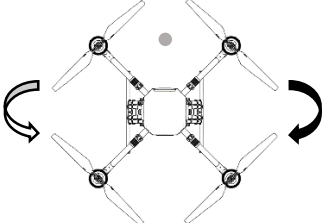
Remote Controller	Aircraft  indicates the nose direction	Function
-------------------	---	----------

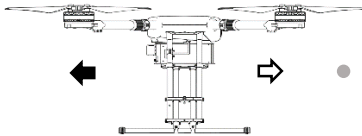
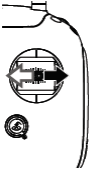
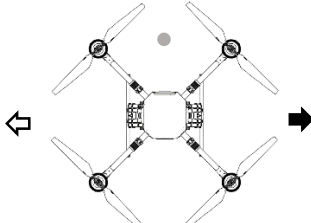
(Mode 2)	and ● indicates the tail direction.)	
		<p>Moving the Left Stick up/down changes the aircraft's elevation. Push it up to ascend and down to descend.</p> <p>Use this stick to take off when the motors are spinning at idle speed. The aircraft will hover in place if the Left Stick is released.</p>
		<p>Moving the Left Stick left/right changes the heading of the aircraft. Push it left to rotate the aircraft counterclockwise, and right to rotate the aircraft clockwise.</p>
		<p>Moving the Right Stick up/down changes the aircraft's forward and backward pitch. Push it up to fly forwards and down to fly backwards.</p> <p>Push the Right Stick further for a larger pitch angle and faster flight.</p>
		<p>Moving the Right Stick left and right changes the aircraft's left and right pitch. Push it left to fly left and right to fly right.</p> <p>Push the Right Stick further for a larger pitch angle and faster flight.</p>

⚠ Always push the control sticks gently to prevent sudden and unexpected movements of the aircraft.

Flight Mode Switch

Toggle the Flight Mode Switch to select a flight mode, F-mode, A-mode or

P-mode. For the positions of the flight modes, see the pictures below.

Figure	Flight Mode
	F-mode
	A-mode
	P-mode

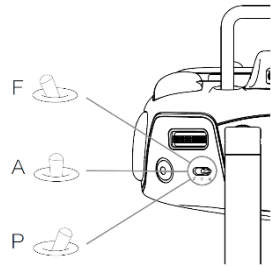

P-mode (Positioning): The aircraft uses the GPS for positioning. In P-

mode, the aircraft will switch automatically between the two modes listed below based on the GPS signal strength:

P-GPS: The GPS signal is strong and the aircraft is using the GPS for positioning.

P-ATTI: The GPS signal is weak and the aircraft is only using its barometer for positioning. Its altitude can still be stabilized, but the aircraft will drift more than it will in P-GPS Mode.

A-mode (Attitude): When the GPS is unavailable, the aircraft will only use its barometer for positioning and altitude control.

F-mode (Function): In F-mode, features like IOC and SDK can be used. The flight mode is set to P-mode by default.

If you want to use other flight modes, connect the remote controller to your mobile device, launch the DJI GO app, enter the "Camera" screen, tap "Advanced Settings" and slide the slider next to "Enable Multiple Flight Mode" to right. Then you can set the flight mode to the one you want.

RTH Button

Press and hold the RTH button until the remote controller emits a sound like “D. DD” to start the Return-to-Home procedure. The LED around the RTH Button will flash white when the aircraft is entering the RTH mode. The aircraft will then return to the last recorded Home Point. Press this button again to cancel the RTH procedure and regain control of the aircraft. For more details, refer to “Return-to-Home and Dynamic Home Point” on page 26.

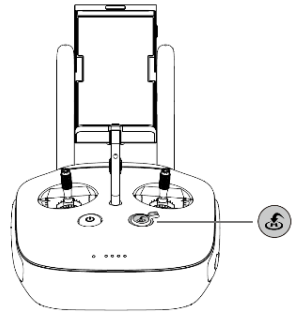

Connecting Mobile Device

Tilt the Mobile Device Holder to the desired position. Press the button on the side of the Mobile Device Holder to release the clamp and place your mobile device into the clamp. Adjust the clamp down to secure your mobile device. To connect your mobile device to the remote controller with a USB cable, plug one end of the cable into your mobile device and the other end into the USB port on the back of the remote controller.

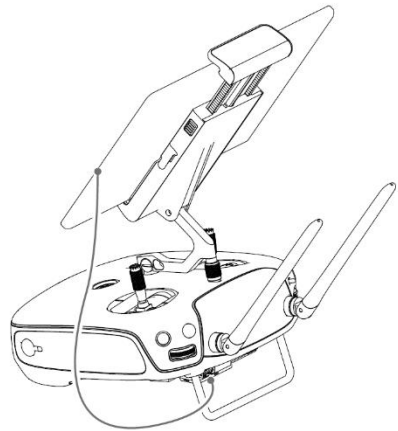

Optimal Signal Transmission Range

The signal transmission between the aircraft and remote controller is best within the range displayed in the picture below:



Strong



Weak

Optimal Signal Transmission Range

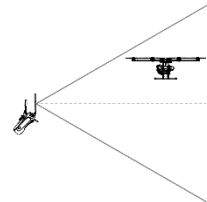

The position of the antennas required for the optimal signal transmission range varies depending on the position of the aircraft. Open up the antennas on the remote controller to optimize transmission range. Ideally, the flat surface

of the antenna should be facing the aircraft. If the signal is weak, fly the aircraft closer to you. Ensure that the aircraft is flying within the optimal transmission range. Adjust the distance and position between the operator and aircraft to achieve the optimal signal transmission performance.

Remote Controller Status LED

The Status LED shows the connection status between the remote controller and aircraft while the RTH Status LED indicates the Return-to-Home Status of the aircraft. The table below shows the Status LED and RTH Status LED on the remote controller.

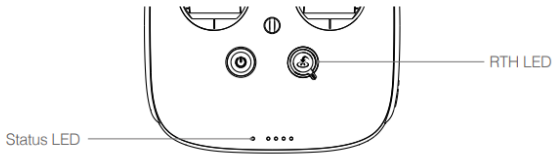

Status LED	Alarm	Remote Controller Status
Solid Red	Chime	The remote controller is disconnected from the aircraft.
Solid Green	Chime	The remote controller is connected to the aircraft.
Flashing Red Slowly	D-D-D.....	Remote controller error
RTH LED	Alarm	Aircraft Status
Solid White	Chime	The RTH initiates.
Flashing White	D . . .	The RTH command is sent to the aircraft.
Flashing White	DD	The aircraft is returning to the Home Point or descending automatically.

 The Status LED will flash red and sound an alert when the battery level is critically low.

Linking the Remote Controller With the Aircraft

The remote controller is linked to your aircraft by default. Linking is only required when a new remote controller is used for the first time. Follow these steps to link a new remote controller:

1. Download DJI Assistant 2 from <http://www.dji.com/cn/product/a3/download>.
2. Retain a distance of 1 to 2 meters between the aircraft and remote controller.
3. Power on the remote controller and connect it to your mobile device. Power on the remote controller and connect it to your mobile device.
4. Go to the DJI GO app > Camera >  > Remote controller Settings > Linking Remote Controller.
5. The remote controller Status LED will blink blue and beep to indicate that the remote controller is ready to be linked.

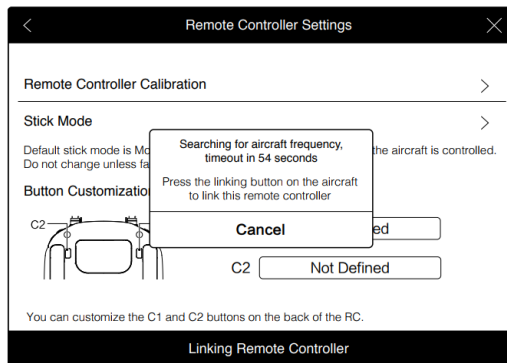

6. Launch DJI Assistant 2 and click "DJI LightBridge 2", "Settings" and "Link Air System". After the linking is successful, the Status LED on the remote controller will be solid green.

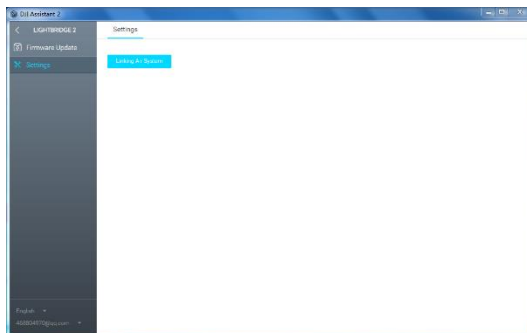



The remote controller will disconnect from the linked aircraft if another remote controller attempts to link to the same aircraft.



Remote Controller Compliance Version

The WIND-4's remote controller meets FCC and CE regulations.

Return-to-Home and Dynamic Home Point

Return-to-Home

Return-to-Home (RTH) refers to the process in which the aircraft automatically returns to the last recorded Home Point. WIND-4 comes with three RTH modes: Smart RTH, Low Battery RTH and Failsafe RTH.

	GPS	Description
Home Point		When the GPS signal is strong (i.e. the green GPS icon is followed by at least two green bars ) during takeoff, the location where the aircraft takes off will be recorded as the Home Point. The Aircraft Status Indicator will flash quickly when the Home Point has been recorded. You can update the Home Point via the DJI GO app.

Smart RTH

To initiate Smart RTH, use the RTH button on the remote controller or tap the RTH icon in the DJI GO app and follow the on-screen instructions when GPS is available. The aircraft then will automatically return to the last recorded Home Point. Use the remote controller to control the aircraft's orientation to avoid obstacles. Press and hold the Smart RTH button once to start Smart RTH, and press the Smart RTH button again to terminate Smart RTH and regain full control of the aircraft.

Low Battery RTH

Low Battery RTH will be triggered when the DJI Intelligent Flight Battery's charge drops to a point that may affect the safe return of the aircraft. You are advised to fly your aircraft to the Home Point or land it immediately when prompted to do so. A warning will be shown in the DJI GO app when a low battery warning is triggered. The aircraft will automatically return to the Home Point if no action is taken after a ten-second countdown. You can cancel the RTH procedure by pressing the RTH button on the remote controller. The thresholds for these warnings are automatically determined based on the aircraft's current height and distance from the Home Point.

The aircraft will land automatically if the current battery charge can only allow the aircraft to descend from its current height. You can still use the remote controller to alter the aircraft's orientation during landing.

The Battery Level Indicator that will be displayed in the DJI GO app is shown below:

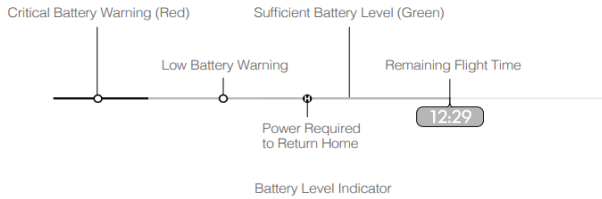

Battery Level Warning	Description	Aircraft Status Indicator	DJI GO App	Flight Instruction
Low Battery Level Warning	The remaining charge is only sufficient for RTH.	Flashing red slowly	Tap “Go-home” to have the aircraft return to the Home Point and land automatically, or “Cancel” to resume normal flight. If no action is taken, the aircraft will automatically return to the Home Point and land after 10 seconds. The remote controller will sound an alarm.	Fly the aircraft to the Home Point and land it as soon as possible, then stop the motors and replace the battery.
Critically Low Battery Level Warning	The remaining charge is only sufficient for landing from the current height.	Flashing red quickly	The Aircraft Status Indicator will flash red and the aircraft will start to descend. The remote controller will sound an alarm.	Allow the aircraft to descend and land automatically.



When Critically Low Battery Level Warning is triggered and the aircraft begins to land automatically, you can push the left stick upward to make the aircraft hover at its current altitude and then navigate it to a location that is suitable for landing.

The colored zones and markers on the Battery Level Indicator bar show the estimated remaining flight time. They will change according to the aircraft's height and distance from the Home Point.

Failsafe RTH

Failsafe RTH is activated automatically if the remote controller signal is lost for more than three seconds, provided that the GPS signal is strong (the GPS icon is green), the compass is working normally and the Home Point has been recorded successfully. You can interrupt the Failsafe RTH and regain control of the aircraft if the remote controller signal is recovered.



The aircraft descends and lands automatically if Failsafe RTH is triggered when the aircraft is flying within a 20 meter (65 foot) radius of the Home Point. The aircraft cannot return to the Home Point when GPS signal is weak or unavailable. During Failsafe RTH, the aircraft cannot avoid obstacles. Before flight, please set the Failsafe RTH height higher than any obstacles in the flight area under Advanced Settings in the DJI GO app. Launch DJI GO, enter the "Camera" screen and select "Mode > Advanced Settings > Failsafe Mode" to set the Failsafe altitude.

The aircraft will stop ascending and return to the Home Point if you move the throttle stick during Failsafe RTH.

Dynamic Home Point

Dynamic Home Point can be used when you are moving while flying the WIND-4, such as in a car or on a boat.



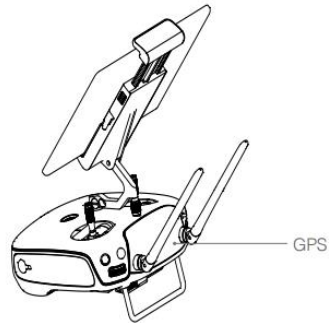

When Dynamic Home Point is enabled, the aircraft's Home Point will be updated in real time and the remote controller's GPS location will be recorded as the latest Home Point. Locations listed below can be set as a Dynamic Home Point:

1. Set the aircraft's current coordinates as the new Home Point.
2. Set the remote controller's coordinates as the new Home Point



 When setting a Home Point with the built-in GPS module in the remote controller, ensure that there is no obstacle over the GPS or tall building around.

Perform the following steps to enable Dynamic Home Point:

1. Connect the remote controller to the mobile device, launch the DJI GO app and enter the "Camera" screen.
2. Tap  and select . In this case, the remote controller's coordinates will be recorded as the aircraft's latest Home Point.
3. Tap  and select . In this case, the aircraft's coordinates will be recorded as the latest Home Point.
4. After the Home Point has been set successfully, the Aircraft Status Indicator will flash green quickly.

Flight

Operation Environment Requirements

1. DO NOT use the aircraft in severe weather conditions, including wind speeds exceeding 10 m/s, snow, rain and fog, etc.
2. Only fly in open areas. Tall structures and large metal structures may affect the accuracy of the on-board compass and GPS system.
3. Avoid obstacles, crowds and animals, etc.
4. Minimize interference by avoiding areas with high levels of electromagnetism, including base stations and radio transmission towers, etc.
5. Ensure that GPS signal is strong during operation.
6. The compass and GPS will not work in Polar Regions of earth and the aircraft will switch to A-mode automatically.

Flight Limits and No Fly Zones

All unmanned aerial vehicle (UAV) operators should abide by all regulations set forth by government and regulatory agencies including the ICAO and FAA. For safety reasons, flights are limited by default, which helps you operate this product safely and legally. Flight limitations include height limits, distance limits and No Fly Zones.

When operating in P-mode, height limits, distance limits and No Fly Zones function concurrently to manage flight safety. In A-mode, only height limits are in effect, which by default prevents the aircraft altitude from exceeding 120 meters.

Maximum Height and Radius Limits

The maximum height and radius limits can be changed in the DJI GO app. Once set, your WIND-4 will fly in a restricted cylinder that is determined by these settings. The tables below show the details of these limits.

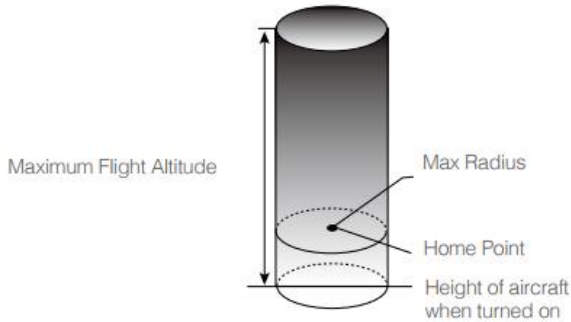

Safe to Fly (Strong GPS Signal) Flashing Green			
	Flight Limit	DJI GO App	Aircraft Status Indicator
Max. Height	Aircraft's height cannot exceed the specified value.	Warning: Height limit reached.	None
Max. Radius	Flight distance must be within the max radius.	Warning: Distance limit reached.	Flashing red rapidly when close to the max radius

Safe to Fly (No GPS Signal) Flashing Yellow			
	Flight Limit	DJI GO App	Aircraft Status Indicator
Max. Height	When the max. height set in the DJI GO app is less than or equal to 500 meters (1640 feet), the aircraft's height cannot exceed the max. height set in the DJI GO app. When the max. height set in the DJI GO app is more than 500 meters (1640 feet), the aircraft's height cannot exceed 500 meters (1640 feet).	Warning: Height limit reached.	None

Max. Radius	No limit		
----------------	----------	--	--

 If the aircraft flies out of the limit, you can still control the aircraft via the remote controller, but cannot fly it any further. If the aircraft flies out of the maximum radius, it will fly back within the maximum radius automatically when the GPS signal is strong.

No Fly Zones

No Fly Zones are divided into Airports and Restricted Areas. All No Fly Zones are listed on the DJI official website at <http://www.dji.com/flysafe/no-fly>.

Airport (With GPS)



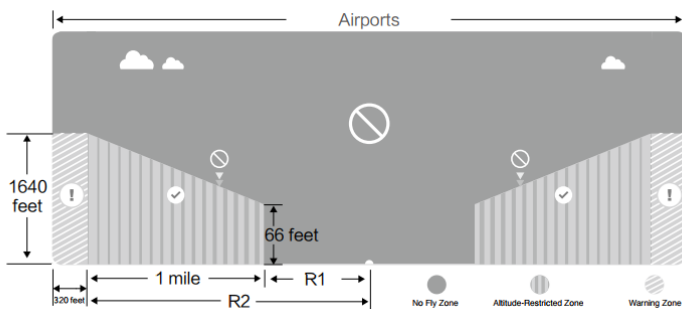



- [1] Airport No Fly Zones include No Fly Zones and Restricted Altitude Zones. Flight is prevented in No Fly Zones but is allowed with height restrictions in the Restricted Altitude Zones.
- [2] R1 meters (the value of the R1 depends on the size and shape of the airport) around the airport is a No Fly Zone, inside of which takeoff is prohibited.
- [3] From R1 meters to R1+1 meters around the airport the flight altitude is limited to a 15 degree inclination. Starting at 20 meters (65 feet) from the edge of airport and radiating outward. Flight altitude is limited to 500 meters (1640 feet) at R1+1 meters.
- [4] When the aircraft comes within 320 feet (100 meters) of a No Fly Zone, a warning will be shown in the DJI GO app.

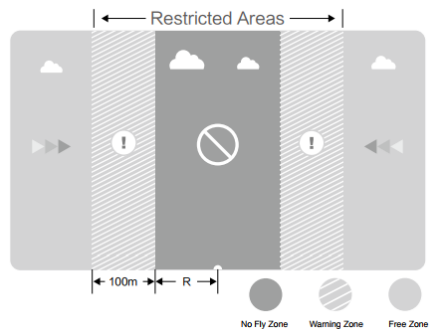



Restricted Areas (With GPS)

- [1] Restricted Areas do not have flight altitude restrictions.
- [2] R meters around the designated restriction area is a Take-off Restricted Area. Aircraft cannot take off within this zone. The value of R varies based on the definition of the restricted areas.
- [3] A Warning Zone has been set around the Restricted Area. When the aircraft approaches within 100 meters (320 feet) of this zone, a warning will be shown in the DJI GO app.



Safe to Fly (GPS)  Blinking Green Slowly			
Zone	Restrictions	DJI GO App Warning	Aircraft Status Indicator
No Fly Zone 	Motors will not start.	Warning: You are in a no fly zone. Takeoff prohibited.	 Blinking Red
	If the aircraft loses GPS signal and enters the restricted area but regains GPS signal afterwards, the aircraft will enter Semi-Automatic Descent and land itself.	Warning: You are in a no fly zone. Automatic landing has begun. (If the aircraft is within R1)	
Altitude-Restricted Zone 	If the aircraft loses GPS signal and enters the restricted area but regains GPS signal afterwards, it will descend to a safe altitude and hover 15 feet below the safe altitude.	Warning: You are in a restricted zone. Descending to a safe altitude. (If the aircraft is within R2 but outside R1) Warning: You are in a restricted zone. Max flight height restricted between 20 and 500 m. Fly Cautiously.	
Warning Zone 	No flight restrictions.	Warning: You are approaching a Restricted Area. Fly cautiously.	
Free Zone 	No flight restrictions.	None.	None.

 Semi-Automatic Descent: All stick commands are available except the throttle stick command during landing. Motors will stop automatically after landing. The Flight Mode Switch needs to be toggled to regain control of the aircraft. This is the same as regaining control during RTH.

 When flying in restricted-altitude flight zone and warning zone, the Aircraft Status Indicator will flash yellow quickly for three seconds, and then start indicating the current flight status for five seconds. DO NOT fly close to airports, highways, railway stations, railway lines, city centers or other busy areas to ensure safety. Try to fly the aircraft within visual range.

Preflight Checklist

1. Ensure that the remote controller, Intelligent Flight Battery and mobile device are fully charged.
2. Ensure that all components are intact. If a component is worn or damaged, please replace it with an intact one before flight.
3. Ensure that the propellers are intact and mounted firmly and correctly. The propellers should be unfolded fully.
4. Calibrate the compass before flight.
5. Check whether the motors work normally after power-on.
6. Check whether the DJI DO app runs normally.

Flight Status Indicator

The WIND-4 comes with front LEDs, rear LEDs and an Aircraft Status Indicator.

The front LEDs and rear LEDs show the orientation of the aircraft.

The Aircraft Status Indicator indicates the system status of the flight controller. The table below shows different indications of the Aircraft Status Indicator.

Aircraft Status Indicator Description	
Flashing Red, Green and Yellow	Power-on and self-check
Alternatively	
Flashing Yellow Four Times	Warming up
Flashing Green Slowly	Safe to fly (P mode with GPS)
Flashing Yellow Slowly	Safe to fly (Without GPS)
Flashing Purple Twice	Manual mode
Flashing Green Quickly for 1.5 Seconds	Home Point, Point of Interest, or Smart Course Angle set successfully
Warning	
Flashing Yellow Quickly	Remote controller signal lost
Flashing Red Slowly	Low battery level warning
Flashing Red Quickly	Critically low battery level warning
Flashing Red Alternatively for 0.6 Seconds	IMU error
Solid Red	Critical error
Flashing Red and Yellow Alternatively	Compass calibration required

Calibrating the Compass

The compass must be calibrated before your first flight, otherwise, the aircraft may not work properly. The compass is a very sensitive instrument that requires regular calibration to ensure the optimal flight performance. Abnormal compass data due to a lack of calibration can lead to poor flight performance or even failure. Regular calibration enables the compass to keep the optimal performance.

⊘ DO NOT calibrate the compass where there is a chance of strong magnetic interference, such as magnetite quarries, parking structures and underground steel reinforcements.

DO NOT carry ferromagnetic objects, such as cellular phones, with you during calibration.

DO NOT calibrate beside massive metal objects.

DO NOT calibrate in an indoor space.

Calibration Procedures

Perform the following steps on an open area to calibrate the compass:

1. Launch the DJI GO app, enter the “Camera” screen, tap the “Aircraft Status” bar and “Calibrate” beside “Compass”.
2. When the Aircraft Status Indicator is solid yellow, the compass calibration initiates.
3. Hold the aircraft horizontally and rotate it 360 degrees. The Aircraft Status Indicators will be solid green.

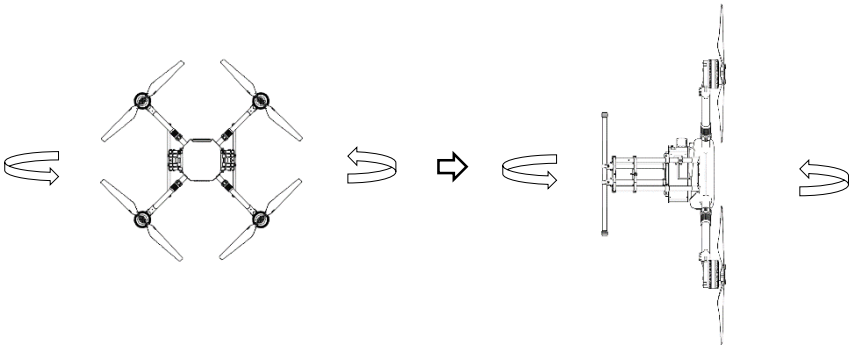

4. Hold the aircraft vertically with its nose pointing downward and rotate it 360 degrees around the central axis.
5. When the Aircraft Status Indicator is flashing normally to show the current status of the aircraft, the compass calibration is successful. If the Aircraft Status Indicator is flashing red, the compass calibration failed. In this case, please recalibrate the compass from step 1.

If the Aircraft Status Indicator is flashing red and yellow alternatively after the calibration completed, the compass has been interfered. In this case, recalibrate the compass in a place free of interference.

A prompt stating that compass calibration is required will pop up on the DJI GO app when the aircraft's compass needs to be calibrated before take-off. After the compass has been calibrated successfully, this prompt will disappear.

When to Recalibrate

1. The compass data is abnormal and the Aircraft Status Indicator is flashing yellow and green alternatively.
2. The aircraft is flying in a location that is far from your last flight.
3. The aircraft's mechanical structure has been changed.
4. Severe drifting occurs during flight. For example, the aircraft cannot fly in a straight line.

Auto Takeoff and Auto Landing

Auto Takeoff

Auto takeoff can be used when the Aircraft Status Indicator is flashing green. Follow the steps below to use the auto takeoff feature:

1. Launch the DJI GO app and enter the "Camera" screen.
2. Ensure that the aircraft is in P-mode.
3. Conduct pre-flight check according to the on-screen instructions.
4. Tap "" and check whether the conditions are safe to fly. If yes, slide the icon to the right to confirm.
5. The aircraft will take off automatically and hover at 1.2 meters above ground.

Auto-Landing

Auto-landing can be used when the Aircraft Status Indicator is flashing green. Follow the steps below to use the auto-landing feature:

1. Ensure that the aircraft is in P-mode.
2. Tap "" and check whether the landing condition is ideal. If yes, tap "Confirm".
3. The aircraft will land in place and then turn off.

Starting and Stopping the Motors

Starting the Motors

The Combination Stick Command (CSC) listed below is used to start and stop the motors. After the CSC has been conducted and the motors start, please release the sticks.



Stopping the Motors

There are two methods to stop the motors.

1. When the aircraft has landed, push the throttle stick down fully ①, then perform the CSC to stop the motors ②. Release two sticks once the motors have stopped.
2. When the aircraft has landed, push the throttle stick down fully and hold. The motors will stop after three seconds.



⚠ Do not conduct the CSC when the aircraft is mid-flight. Otherwise, the aircraft will stop during flight and then crash.

Flight Test

1. Place the aircraft on even ground with the Aircraft Status Indicator facing you.
2. Turn on the remote controller and Intelligent Flight Battery.
3. Launch the DJI GO app, connect the mobile device with WIND-4 and enter the “Camera” screen.
4. Wait until the Aircraft Status Indicator flashes green and “SAFE TO FLY (GPS)” is shown in the DJI GO app. Then perform CSC to start the motors.
5. Push the throttle stick up to take off.
6. To land, ensure the Operation Mode Switch is toggled to Manual Operation Mode, hover over a level surface and gently pull down on the throttle stick to descend slowly.
7. After landing, pull the throttle stick down fully for more than three seconds until the motors stop.
8. Power off the aircraft and then the remote controller.

⚠ When the Aircraft Status Indicator flashes yellow quickly during flight, the aircraft has entered Failsafe RTH mode.
When the Aircraft Status Indicator flashes red during flight, the critically low battery level warning has been triggered. In this case, please follow the instructions in the DJI GO app.

Appendix

Specifications

Airframe

Diagonal Wheelbase	1060 mm
Propulsion System	
Model	E5000 Pro
Motors	
Stator Size	100x10 mm
KV	120 rpm/V
Max. Thrust	14 kg/rotor when the elevation is 0 m above sea level
ESCs	
Max. Allowable Current	80 A
Max. Operating Voltage	52.2 V
Compatible Signal Frequency	30-500 Hz
PWM Input Signal Level	3.3 V/5 V
Foldable Propellers	
Material	High-strength plastic
Size	28×7 inch
ESC	520 g
Flight Parameters	
Total Weight (With a DZ-12000 Battery)	11.7 kg
Max. Takeoff Weight	21 kg (10.5 min)
Battery	DZ-12000 battery
Hovering Time	22.07 min (DZ-12000 battery + Zenmuse Z3)
Max. Flying Speed	18 m/s
Max. Service Ceiling Above Sea Level	3000 m
Operating Temperature Range	-10°C to +40°C
Remote Controller	
Model	GL658C
Operating Frequency	2.400 GHz to 2.483 GHz
Max. Transmission Range (Unobstructed and Free of Interference)	3 km (FCC) 2.5 km (CE)
Power Supply	Built-in lithium battery
Charging	DJI charger
Output Power	9 W
Operating Temperature Range	-10°C to +40°C
Storage Temperature Range	Less than 3 months: -20°C to +45°C More than 3 months: 22°C to +28°C
Charge Temperature Range	0°C to 40°C
Battery	6000 mAh, 2S LiPo
Charger Input Characteristics	
Model	C03048D

Rated Input Power	110 Vac/220 Vac
Rated Input Voltage	50 Hz/60 Hz
Max. Input Current	15 A
Charger Output Characteristics	
Chargeable Battery Number	2
Charge Method	CC/CV
Rated Output Voltage	22.2 V
Current in Fast Charge Mode	24 A@220 Vac 12 A@110 Vac
Current in Slow charge Mode	12 A
Current in Storage Mode	2.5 A
Charging Efficiency	≥90%@220 Vac ≥85%@110 Vac
Voltage Acquisition Accuracy for One Battery Cell	±10 mV
Temperature Acquisition Accuracy	±3°C
Average Current for One Battery Cell	500 mAh
Rated Output Power	2400 W
Battery	
Model	DZ-12000
Capacity	12000 mAh
Voltage	22.2 V
Battery Type	LiPo12S
Total Weight	3.56 kg
Operating Temperature Range	-10°C to +40°C
Storage Temperature Range	Less than 3 months: -20°C to +45°C More than 3 months: 22°C to +28°C
Charge Temperature Range	0°C to +40°C

FCC Compliance Notice

This device complies with Part 15 of the FCC Rules. Operation is subject to the following two conditions:

- (1) This device may not cause harmful interference, and
- (2) This device must accept any interference received, including interference that may cause undesired operation.

Any changes or modifications not expressly approved by the party responsible for compliance could void the user's authority to operate the equipment.

This equipment has been tested and found to comply with the limits for a Class B digital device, pursuant to part 15 of the FCC Rules. These limits are designed to provide reasonable protection against harmful interference in a residential installation. This equipment generates, uses and can radiate radio frequency energy and, if not installed and used in accordance with the instructions, may cause harmful interference to radio communications. However, there is no guarantee that interference will not occur in a particular installation. If this equipment does cause harmful interference to radio or television reception, which can be determined by turning the equipment off and on, the user is encouraged to try to correct the interference by one or more of the following measures:

- Reorient or relocate the receiving antenna.
- Increase the separation between the equipment and receiver.
- Connect the equipment into an outlet on a circuit different from that to which the receiver is connected.
- Consult the dealer or an experienced radio/TV technician for help.

FCC Radiation Exposure Statement:

This equipment complies with FCC radiation exposure limits set forth for an uncontrolled environment .

This transmitter must not be co-located or operating in conjunction with any other antenna or transmitter.

This equipment should be installed and operated with minimum distance 20cm between the radiator & your body.

WIND-4 and ZENMUSE are trademarks of DJI.

Copyright © 2017 DJI All Rights Reserved.