

# Installation guide XS4-Locker

- Eng Installation guide
- E Guía de instalación
- F Guide d'installation
- D Montageanleitung
- I Guida all'installazione

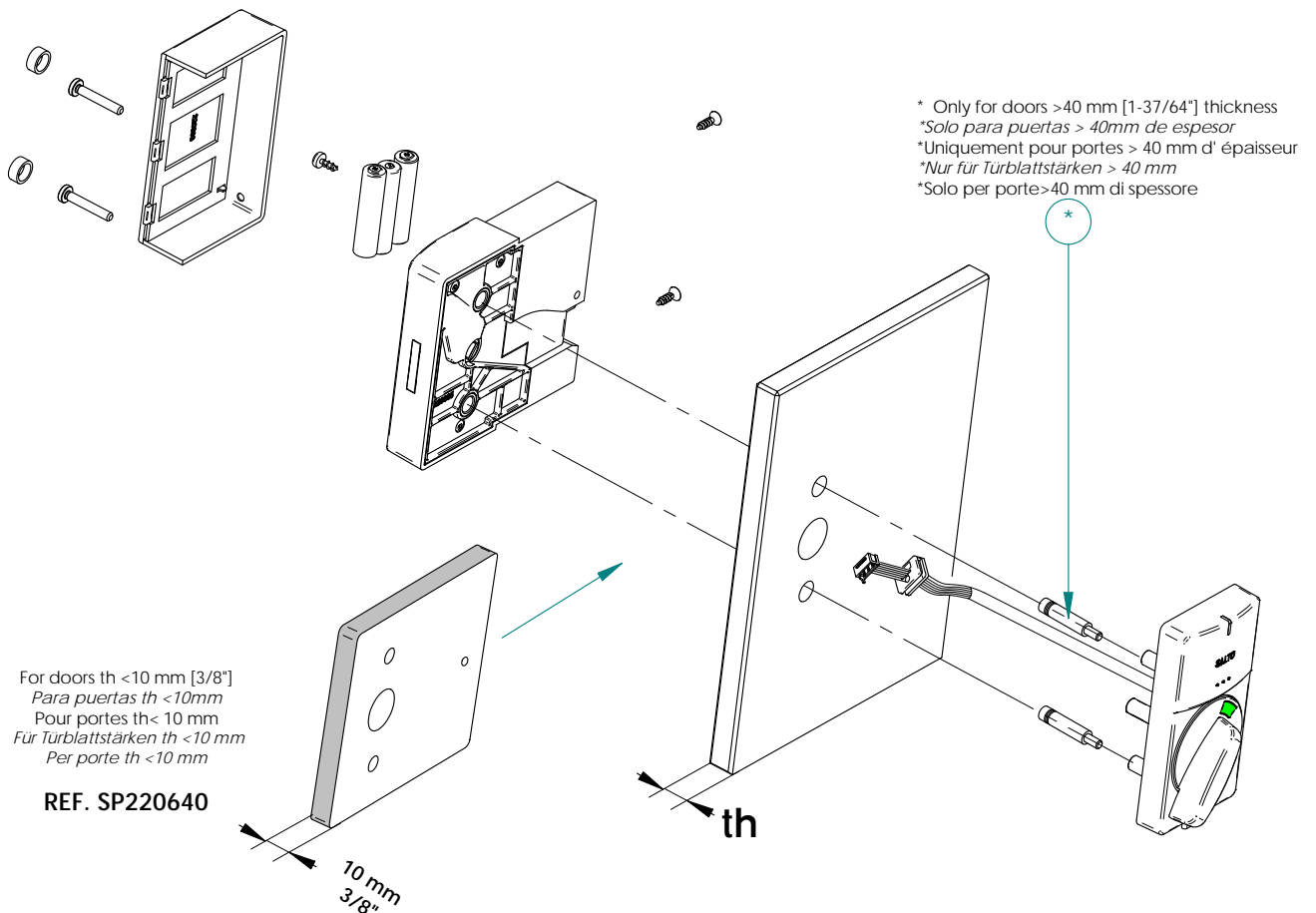

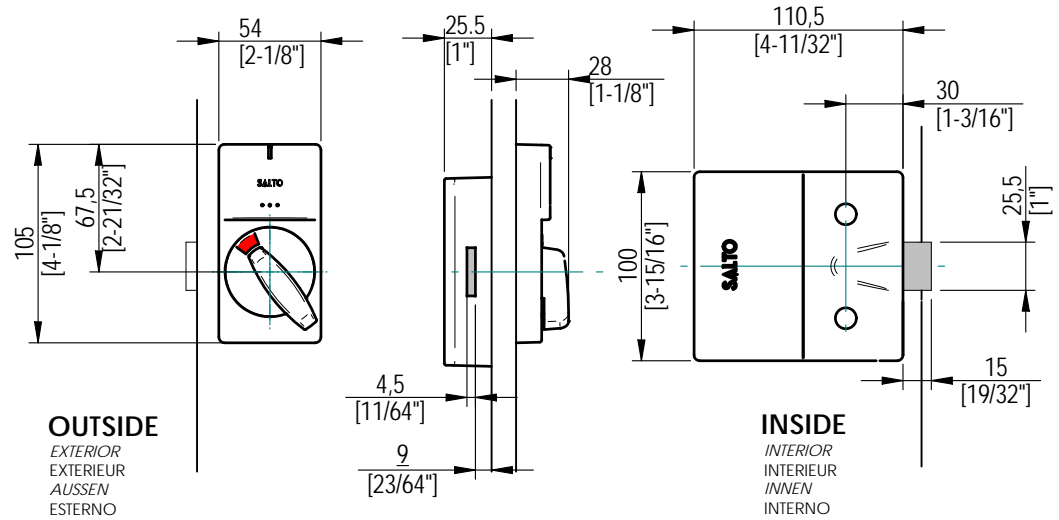
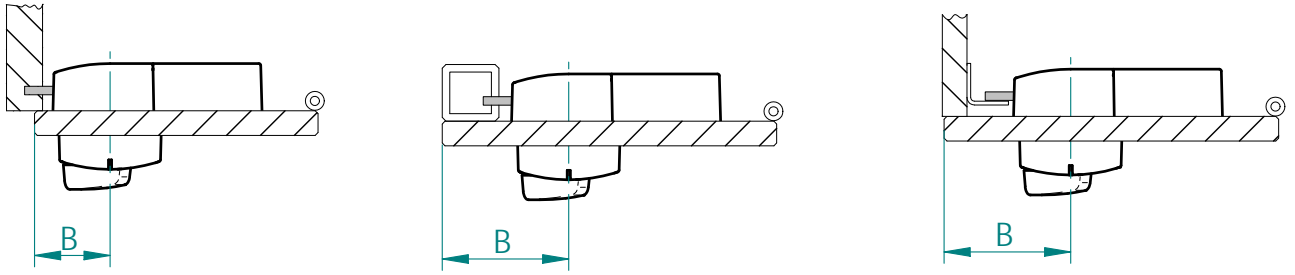

- Ⓔ The dimension B will depend on the door or strike type the lock is going to be installed on.
- Ⓔ La cota B dependera en cada caso del tipo de puerta o cerradero donde se instale la cerradura de taquilla.
- Ⓔ La mesure B dependra dans chaque cas du type de porte ou gâche où va s'installer la serrure vestiaire.
- Ⓔ Maß B ist abhängig von Tür-oder Schließblechart, an der das Schrank-/Kabinenschloss installiert wird.

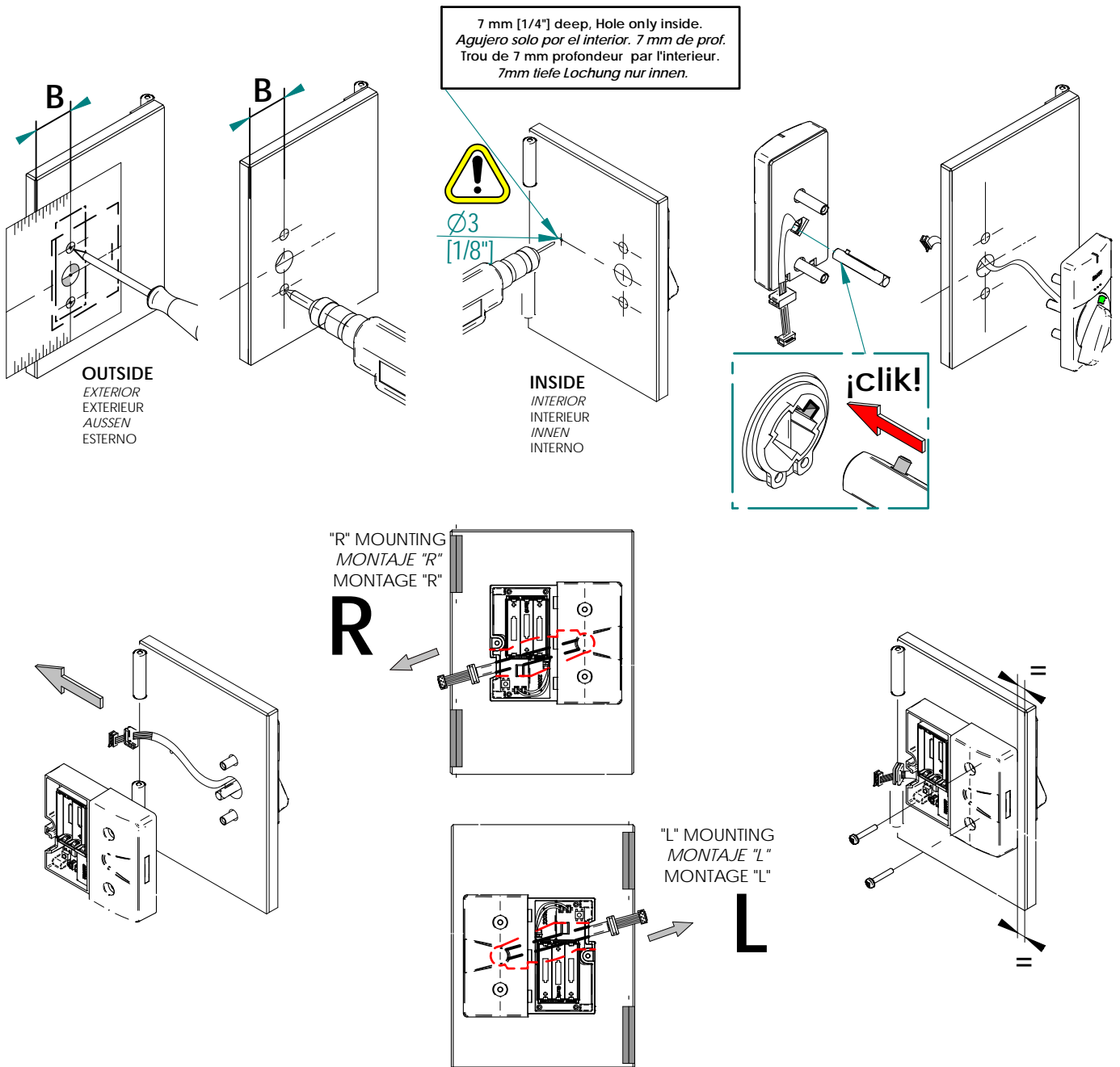

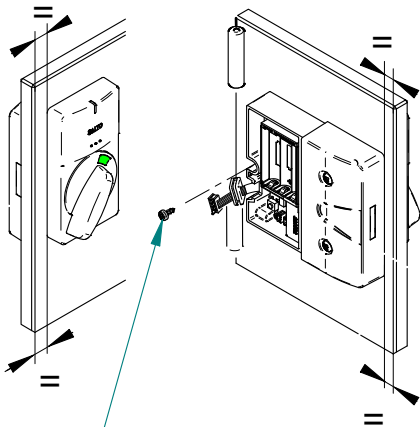

**Fasten with screw to keep it aligned.**  
*Fijar el tornillo para mantener el alineamiento.*  
*Fixer la vis pour assurer l'alignement.*  
*Schraube fixieren, um Ausrichtung beizubehalten.*  
*Fissare la vite per tenela allineata.*

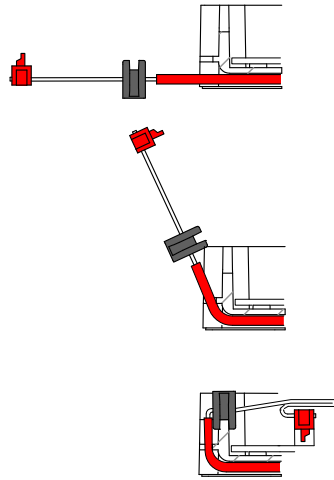

**-Caution !**  
 -Atención  
 -Achtung  
 -Attention  
 -Attenzione

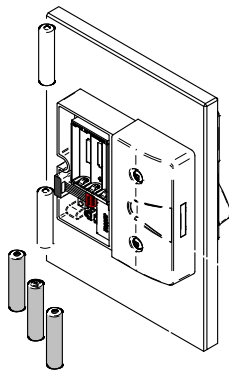
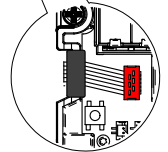
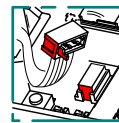
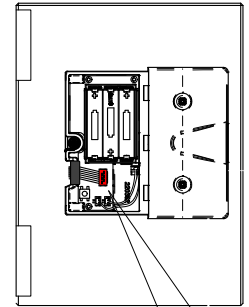

Screw driver  
 Torx T15 TAMPER

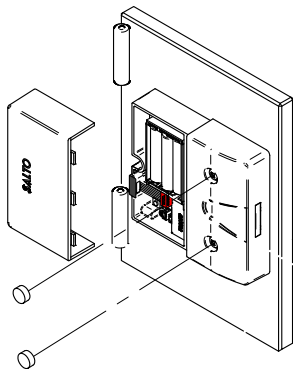

(Eng)

**AT THIS POINT DO NOT  
 CLOSE THE DOOR  
 PROGRAM THE LOCK FIRST**

(E)

**NO CIERRE LA PUERTA.  
 PROGRAME LA CERRADURA**

(D)

**TÜRE NICHT SCHLIESSEN.  
 ZUERST SCHLOSS  
 PROGRAMMIEREN**

(F)

**NE FERMEZ PAS LA PORTE.  
 PROGRAMMEZ LA SERRURE  
 AVANT**

(I)

**PRIMA DI CHIUDERE LA  
 PORTA, PROGRAMMARE LA  
 SERRATURA**

follow user manual

**R**

"R" MOUNTING  
 MONTAJE "R"  
 MONTAGE "R"

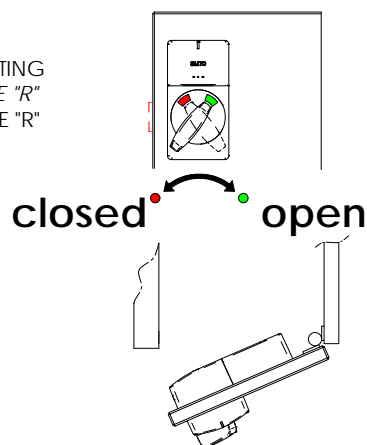

"L" MOUNTING  
 MONTAJE "L"  
 MONTAGE "L"

**L**

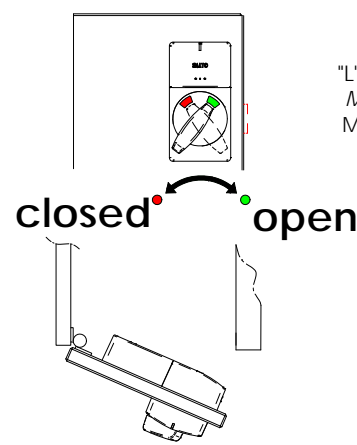

**-Caution !**  
 -Atención  
 -Achtung  
 -Attention  
 -Attenzione



**INSIDE**  
 INTERIOR  
 INTERIEUR  
 INNEN  
 INTERNO

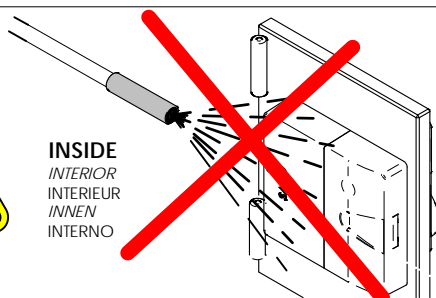



## FCC Compliance Statements

(FCCID: UKCAE9, UKCAE9W, UKCL90, UKCG90, UKCRPOE, UKCNRF, UKCA9XX, UKCA9XW)

This device complies with Part 15 of the FCC Rules. Operation is subject to the following two conditions: (1) this device may not cause harmful interference, and (2) this device must accept any interference received, including interference that may cause undesired operation. Changes or modifications not expressly approved by the party responsible for compliance could void the user's authority to operate the equipment.

*Note:* This equipment has been tested and found to comply with the limits for a Class B digital device, pursuant to part 15 of the FCC Rules. These limits are designed to provide reasonable protection against harmful interference in a residential installation. This equipment generates, uses, and can radiate radio frequency energy and, if not installed and used in accordance with the instructions may cause harmful interference to radio communications. However, there is no guarantee that interference will not occur in a particular installation. If this equipment does cause harmful interference to radio or television reception, which can be determined by turning the equipment off and on, the user is encouraged to try to correct the interference by one or more of the following measures:

- Reorient or relocate the receiving antenna.
- Increase the separation between the equipment and receiver.
- Connect the equipment into an outlet on a circuit different from that to which the receiver is connected.
- Consult the dealer or an experienced radio/TV technician for help.

## Canadian Compliance Statement

(IC: 10088A-AE9, 10088A-AE9W, 10088A-L90, 10088A-G90, 10088A-RPOE, 10088A-NRF, 10088A-A9XX, 10088A-A9XW)

This device complies with Industry Canada licence-exempt RSS standard(s). Operation is subject to the following two conditions: (1) this device may not cause harmful interference, and (2) this device must accept any interference received, including interference that may cause undesired operation. Changes or modifications not expressly approved by the party responsible for compliance could void the user's authority to operate the equipment.

Le présent appareil est conforme aux CNR d'Industrie Canada applicables aux appareils radio exempts de licence. L'exploitation est autorisée aux deux conditions suivantes : (1) l'appareil ne doit pas produire de brouillage, et (2) l'utilisateur de l'appareil doit accepter tout brouillage radioélectrique subi, même si le brouillage est susceptible d'en compromettre le fonctionnement.

## Canadian Compliance Label

(IC: 10088A-AE9, 10088A-AE9W, 10088A-L90, 10088A-G90, 10088A-A9XX, 10088A-A9XW)

### Industry Canada ICES-003 Compliance Label:

CAN ICES-3 (B)/NMB-3(B)

## EU Compliance Statement

EN	Hereby, Salto Systems S.L. (Arkotz Kalea (Pol. Lanbarren), 9 – 20180 Oiartzun– Spain), declares that this access control equipment is in compliance with the essential requirements and other relevant provisions of Directive 1999/5/EC (R&TEE). You will be able to find a copy of the original declaration of conformity at the following Internet address: <a href="http://www.saltosystems.com/declarations">http://www.saltosystems.com/declarations</a>
ES	Por medio de la presente Salto Systems S.L. (Arkotz Kalea (Pol. Lanbarren), 9 – 20180 Oiartzun– Spain) declara que este equipo de control de accesos cumple con los requisitos esenciales y cualesquiera otras disposiciones aplicables o exigibles de la Directiva 1999/5/CE (R&TEE). Podrá encontrar una copia de la declaración de conformidad original en la siguiente dirección de internet: <a href="http://www.saltosystems.com/declarations">http://www.saltosystems.com/declarations</a>
FR	Par la présente Salto Systems S.L. (Arkotz Kalea (Pol. Lanbarren), 9 – 20180 Oiartzun– Spain) déclare que l'appareil access control equipment est conforme aux exigences essentielles et aux autres dispositions pertinentes de la Directive 1999/5/CE (R&TEE). You will be able to find a copy of the original declaration of conformity at the following Internet address: <a href="http://www.saltosystems.com/declarations">http://www.saltosystems.com/declarations</a>
DE	Hiermit erklärt Salto Systems S.L. (Arkotz Kalea (Pol. Lanbarren), 9 – 20180 Oiartzun– Spain), dass sich das Gerät access control equipment in Übereinstimmung mit den grundlegenden Anforderungen und den übrigen einschlägigen Bestimmungen der Richtlinie 1999/5/EG (R&TEE). You will be able to find a copy of the original declaration of conformity at the following Internet address: <a href="http://www.saltosystems.com/declarations">http://www.saltosystems.com/declarations</a>
DU	Hierbij verklaart Salto Systems S.L. (Arkotz Kalea (Pol. Lanbarren), 9 – 20180 Oiartzun– Spain) dat het toestel access control equipment in overeenstemming is met de essentiële eisen en de andere relevante bepalingen van richtlijn 1999/5/EG (R&TEE). You will be able to find a copy of the original declaration of conformity at the following Internet address: <a href="http://www.saltosystems.com/declarations">http://www.saltosystems.com/declarations</a>

## Mechanical Warnings

In order to assure a good performance for the device, Salto recommends to use a certified mortise lock and make sure that it is in good condition. Do not knock the device while mounting, if necessary, loose the trims fixation. Do not bring the device into contact with oil, paints or acids. Do not paint the door with the mortise lock fixed to the door.  
CLEANING THE ELECTRONIC FURNITURE: You can use a damp cloth from soapy water. Never use abrasive soaps or sprays. It is important to clean stainless steel regularly.

## Legal Warnings

SALTO shall not be liable for any losses, personal damages or claims arising out of, or in connection with the wrong fitting of the cylinders or bad programming that can cause blocking of entries and exits i.e. blocking entrance, exit of Injured or people in danger.  
Do you have the programming keys or management software (not included in this box)? If not, then take note that when the door is closed without having been programmed it will automatically lock, and can only be opened with a Portable Programming Device. If in any doubt, please contact your supplier or visit our Web site: [www.saltosystems.com](http://www.saltosystems.com)  
According to the fourth point on the SALTO SYSTEMS LIMITED WARRANTY document, the warranty does not cover product failures due to repair installations, modifications or improper service performed by non-Salto authorised persons. The user is not allowed to disassemble the inner electromechanic structure in the SALTO furniture. (for instance, loosening the torx screws) In the case of a user intended intervention at the inner parts, the user will lose any warranty right from SALTO.



N20371

Copyright © 2013 SALTO Systems