



SALUS

C O N T R O L S P L C

RT505RF



Thermostat Receiver Units



RXRT505



RXST625



RXVBC605



RXWBC605

This instruction manual covers the receivers above





RT505TX



ST625TX



0915FLTX



RT305TX



ST325TX



SUPPLIED SEPERATELY



RXRT505



RXST625



RXVBC605



RXWBC605

PRODUCT COMPLIANCE

This product complies with the essential requirements of the following EC Directives:

- Electro-Magnetic Compatibility directive 2004/108/EC
- Low Voltage Directive 2006/95/EEC
- EC Marking directive 93/68/EEC

SAFETY INFORMATION

These instructions are applicable to the Salus Controls model stated on the front cover of this manual only, and must not be used with any other make or model. These instructions are intended to apply in the United Kingdom only, and should be followed along with any other statutory obligations. This accessory must be fitted by a Competent person, and installation must comply with the guidance provided in the current editions of BS7671 (IEE Wiring Regulations) and Part 'P' of the Building Regulations. Failure to comply with the requirements of these publications could lead to prosecution. When fitting the receiver always isolate the AC Mains supply before opening or removing the unit from the wall or wall box.

RT RECEIVER

INTRODUCTION

The RXRT505 is used for the wiring connections and on/off control. The RXRT505 is linked to your thermostat via radio frequency (RF) signal.

Features

- LED status indication
- ON / OFF switch
- 868 MHz communication

CONNECTING THE RXRT505 RECEIVER

The RT Receiver should be mounted in a suitable location that is both accessible for the connection of mains and control wiring, and allows good reception of the RF signal. The receiver needs a 230V AC mains supply to operate, and this should be fused appropriately (13A max.). The receiver should be mounted in a location where it will not come into contact with water, moisture or condensation.

The receiver On/Off switch is accessible from the front face of the receiver, as shown in this picture:



On the front cover of the receiver you will see that there is the On/Off switch and two Light Emitting diodes (LEDs). The switch allows you to turn off the receiver if necessary to prevent it calling for heat. The top LED (red) will illuminate when the switch is in the 'On' position and the unit is receiving power. The top LED (green) illuminates when the receiver is receiving a heat call transmission from the thermostat. The wiring terminals and RF Address Code setting DIP switches are located on the rear of the receiver, as shown above:



RECEIVER WIRING TERMINALS

Terminal	Identifier	Description
1	NO	Normally Open (N/O) Volt free contacts
2	COM	Common terminal (COM) Volt free contacts
3	L	Live supply (230V AC)
4	N	Neutral

TYPICAL WIRING INSTALLATIONS

The RT receiver is wired the same way no matter if you are wirings 230V or 24V, the receiver will always need a 230V Live and Neutral feed connected into L & N terminals. The COM and NO is to be connected to the boilers external loop (see diagram below), if connected in this way the receiver relay can only switch voltage supplied by the boiler.

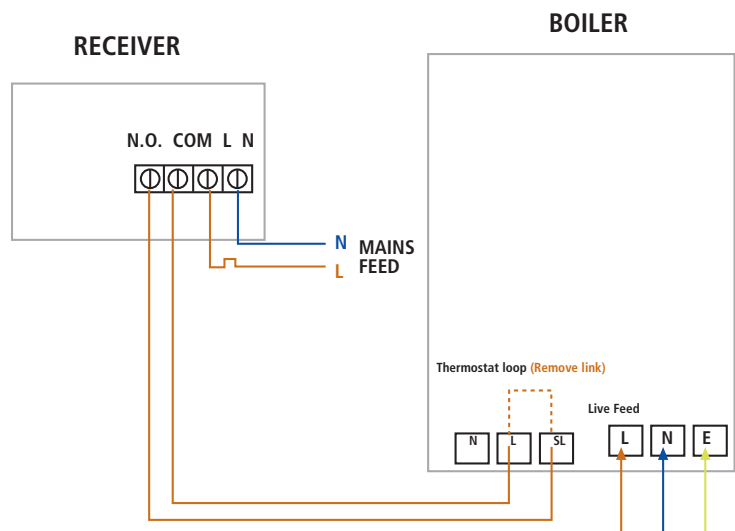

SETTING UP RF COMMUNICATION WITH YOUR THERMOSTAT

RT505TX / RT305TX



Thermostat

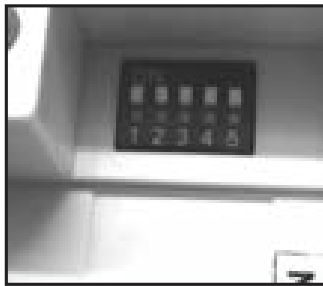

DIP Switches



Jumper Caps

After you have switched the receiver on, the thermostat will automatically pair* with the RT505TX and the RT305TX (only). When the red LED stops flashing, the unit has successfully paired.

If you have difficulty in pairing the thermostat, we recommend changing the address codes in the thermostat and the receiver.

To adjust the RF address code of the receiver, simply push up one or more of the 5 DIP switch levers on the DIP switch bank located on the back of the receiver (the levers are numbered 1 to 5 from bottom to top, as shown in the picture left), and then make a note of the setting of each switch:

To adjust the RF address code of the thermostat, remove one or more of the jumper caps located on the back of the unit (labelled 1,2,3,4 and 5, and shown in the picture left) so that the jumper settings match the settings made on the receiver:

ST325TX / ST625TX

1. Switch power on the receiver, the receiver will now automatically enter pairing mode.
2. Enter Pair Menu on the S-Series thermostat and start the pairing procedure*.
3. When the red LED on the receiver stops flashing, pairing has been successful.

* For full instructions on thermostat pairing see:

RT505TX Manual - Page 13

ST325TX Manual - Page 15

RT305TX Manual - Page 9

ST625TX Manual - Page 11



S-SERIES RECEIVERS

INTRODUCTION

The RXST625 is used for the wiring connections and on/off control. The RXST625 is linked to your thermostat via radio frequency (RF) signal.

Features

- LED status indication
- Manual override
- 868 MHz communication

CONNECTING THE RXST625 RECEIVER

The RT receiver should be mounted in a suitable location that is both accessible for the connection of mains and control wiring, and allows good reception of the RF signal. The receiver needs a 230V AC mains supply to operate, and this should be fused appropriately (13A max.). The receiver should be mounted in a location where it will not come into contact with water, moisture or condensation.



TYPICAL WIRING INSTALLATIONS

The RXST625 receiver is wired the same way no matter if you are wirings 240V or 24V, the receiver will always need a 240V Live and Neutral feed connected into L & N terminals. The COM and NO is to be connected to the boilers External Loop (see diagram below), if connected in this way the receiver relay can only switch voltage supplied by the boiler.

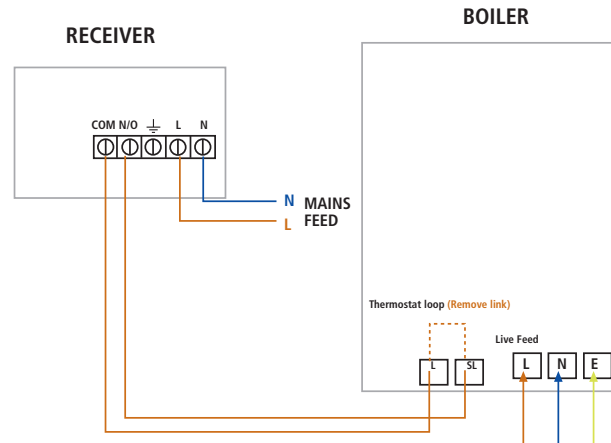

These electrical connections are shown in the table below:

Terminal	Function
COM	Common Contact (volt free input)
NO	Normally Open Contact (volt free output)
	Earth Parking (No electrical connection)
L	Incoming Mains - Live
N	Incoming Mains - Neutral

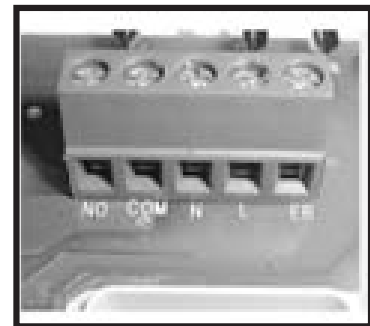

SETTING UP RF COMMUNICATION:

Ensure that the slide switches are in AUTO and ON positions and then press the sync button. Press and hold the SYNC button for at least 3 seconds, then release. The receiver will now enter pairing mode, the green LED will now turn red to indicate that the receiver is ready to pair with the thermostat*.

While the signal is being received, the red LED will stay on until the pairing is successful, when pairing is successful the red LED will turn green.

* For full instructions on thermostat pairing see:

RT505TX Manual - Page 13 ST325TX Manual - Page 15

RT305TX Manual - Page 9 ST625TX Manual - Page 11

RECEIVER LED INDICATORS

The LED indicators on the RXST625 receiver are designed to give a clear and easily understood indication of the current state of the system. The various LED signal combinations and descriptions of what they indicate are shown in the table below:

LED	State	Indication
Blue	On	Receiver is in manual mode and system is calling for heat.
Blue	Flashing once per second	Receiver is in automatic mode and system is calling for heat.
Blue	Off	Receiver is in automatic mode and system is NOT calling for heat
Green	On	Power is on
Green	Flashing for 4 seconds	Receiver has received correct RF address and command signal
Red	On and flashing	Receiver is either receiving a new RF address code in SYNC mode, or has failed to store the new RF address code when in SYNC mode
Yellow	On	Receiver is in failsafe mode after no RF signal received for over 1 hour

The status of the RXST625 receiver is indicated by the use of two bi-colour Light Emitting Diodes (LEDs). The status indicators are:

USER CONTROL FUNCTION SUMMARY

Key/Operation	Functions
Auto	Sets receiver to Automatic mode (default setting)
Manual	Sets receiver to Manual mode
On	Turns relay output ON (default setting)
Cycle	Switches receiver output on and off in a 15 minute cycle (4 minutes on, 11 minutes off)
Off	Turns relay output OFF
SYNC Button	Enables RF signal synchronisation with RXST625 thermostat
Reset Button	Resets the receiver to default (original factory) settings

RECEIVER MODES

The RF receiver can operate in three different modes – AUTO or MANUAL, and also has a FAILSAFE mode of operation. These modes are selected by using the slide switches on the front of the receiver:

AUTO MODE

Moving the slide switch to the 'AUTO' position selects the Automatic operation mode of the RF receiver. In this mode, the receiver will automatically receive an RF signal from the thermostat and control the output relay. When in auto mode, if RF communication between the receiver and thermostat is lost for less than one hour, the receiver remains in the same operating state it was in when the signal was lost. If the RF signal is lost for more than one hour, the receiver will enter Failsafe mode, and control of the receiver output will be based on the setting of the Failsafe mode switch. Please be aware that if the thermostat is operating in Service mode when changing the receiver switch position, the relay output may be affected.

MANUAL MODE

Moving the slide switch to the 'MANUAL' position selects the manual operation mode of the RF receiver. In manual mode, the receiver ignores the RF signal from the thermostat and controls the output relay manually, based on the setting of the failsafe mode switch.

FAILSAFE MODES

Failsafe mode has three user selectable settings – 'ON', 'CYCLE' and 'OFF'. With the failsafe switch in the ON position, the output relay will be turned on, in the OFF position the output relay will be turned off, and in the CYCLE position the output relay will be operated according to a preset time sequence (on for 4 minutes and off for 11 minutes).

When operating in failsafe mode, the LEDs will indicate the receiver relay status as follows:

Mode	LEDs	Indication
On	Blue and Yellow	Each LED lights alternately, approx. once per second
Off	Yellow	On
Cycle	Blue	On for 4 minutes, off for 11 minutes

If required the user can switch to another mode without having to reset the controller; for instance you can switch from auto mode to manual mode with the output relay being controlled accordingly. To illustrate this point, even when switched into manual mode the receiver can still receive the RF signal from the thermostat and once the user switches to auto mode, the output relay will be controlled to turn on or turn off automatically once more.

RXVBC605 RECEIVER

INTRODUCTION

The RXVBC605 is an integral plug-in RF boiler control. The RF boiler control is a direct replacement for the basic time clock or blanking plate usually supplied with the boiler. Installing the RF boiler control takes minutes. Once installed, you will benefit from all the control features of the Salus room thermostat.

INTEGRAL RF BOILER CONTROL

The Integral RF boiler control is the RF receiving unit for your RF room thermostat. This unit uses a plug-in connection to connect directly to your boiler and provides the ON/OFF switching.

Features

- LED status indication
- Plug-in connection to boiler
- 3 position switch
- 868 MHz communication



Mounting the RF Integral Boiler Control to the boiler

DANGER!

- **24V & 230V: Do not Touch Electrical Components or circuits**
- **Isolate mains electricity supply before starting any work and observe all relevant safety precautions.**
- **Follow electro static discharge precaution.**
Do not touch any visible PCB parts or components.

1. Switch off the boiler at its main supply.
2. Remove cover panel or existing control.
3. Insert the integral boiler control ensuring correct location of the rear Connection pins.

For ECOTEC post April 2012 -
remove and discard pins.

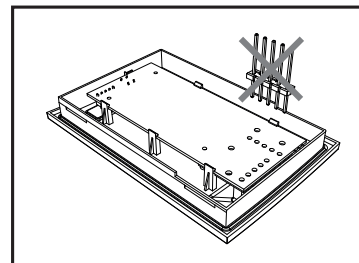

For ECOTEC models prior to
April 2012, use as supplied

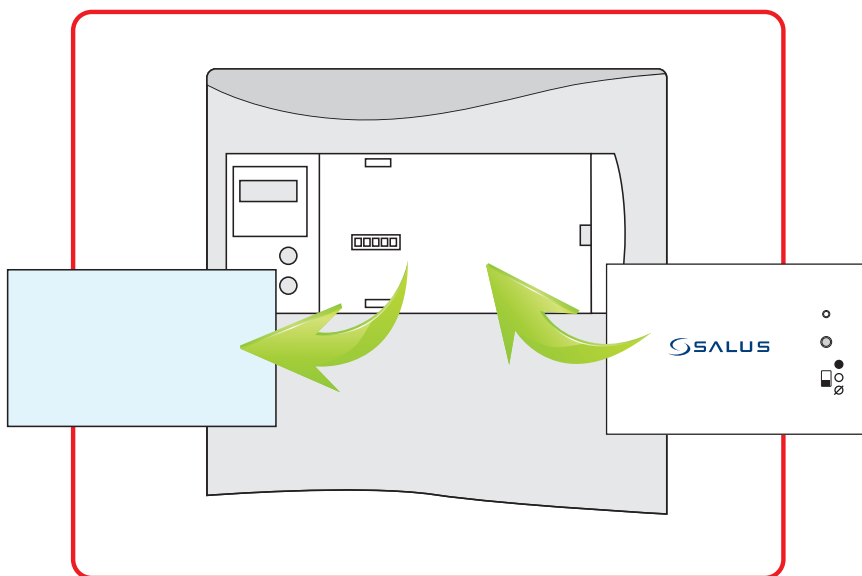
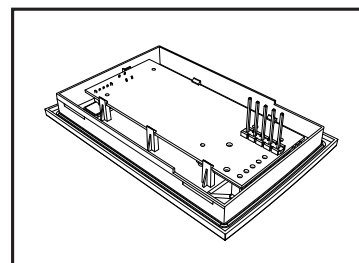

4. Before switching the boiler on at its mains supply, ensure the module switch is in the OFF \emptyset position.

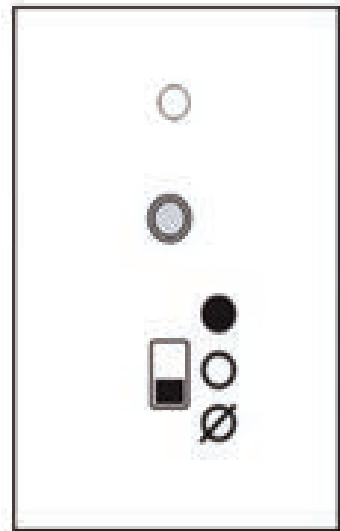

5. To ensure the boiler control is connected properly, please now move the switch to ON \bullet . The boiler should now go on and the LED on the your boiler control should illuminate.

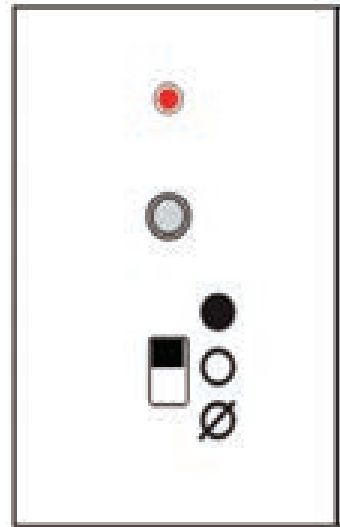

6. Now move the switch back to AUTO \circ .

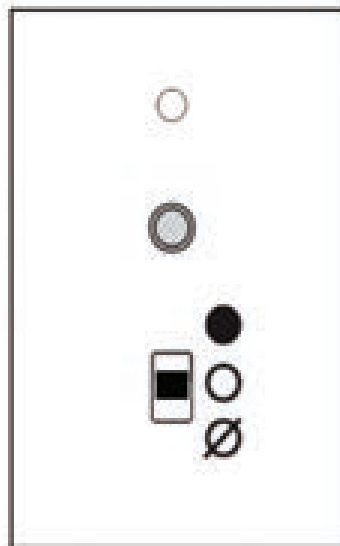

SETTING UP RF COMMUNICATION WITH YOUR THERMOSTAT

1. Ensure the switch on the RF integral boiler module is in the AUTO 

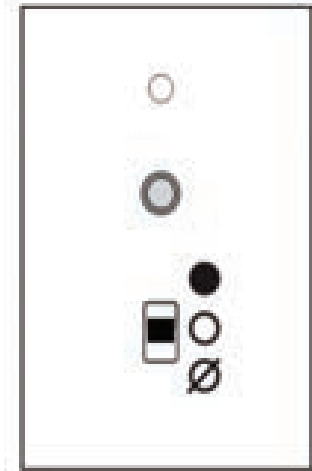

2. Gently press and hold the SYNC button with a blunt object. After 3 seconds the Boiler Control LED will flash once every second to indicate it is ready to pair and ready to receive a signal from the thermostat*.

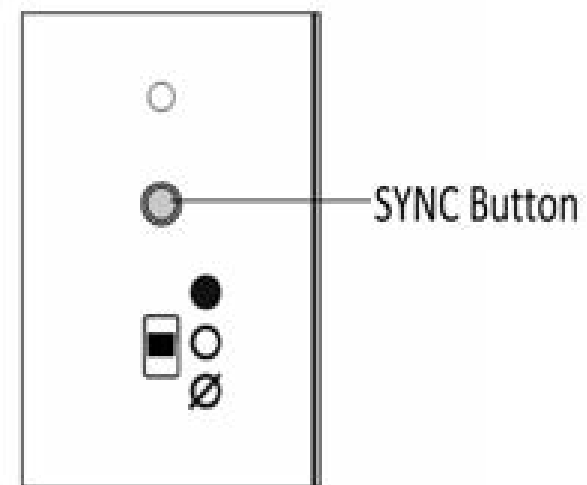

3. The LED will turn off when pairing is successful.

* For full instructions on thermostat pairing see:

RT505TX Manual - Page 13 ST325TX Manual - Page 15
RT305TX Manual - Page 9 ST625TX Manual - Page 11

USER CONTROLS

Integral RF Boiler Control

A – LED

This LED will be on when the thermostat is demanding heat.

B – Mode Switch

- **ON** – Boiler will be on continuous
- **AUTO** – will follow instructions from the thermostat
- ∅ **OFF** – Boiler is off

C – SYNC Button - This is used **only** for pairing the RF communications.

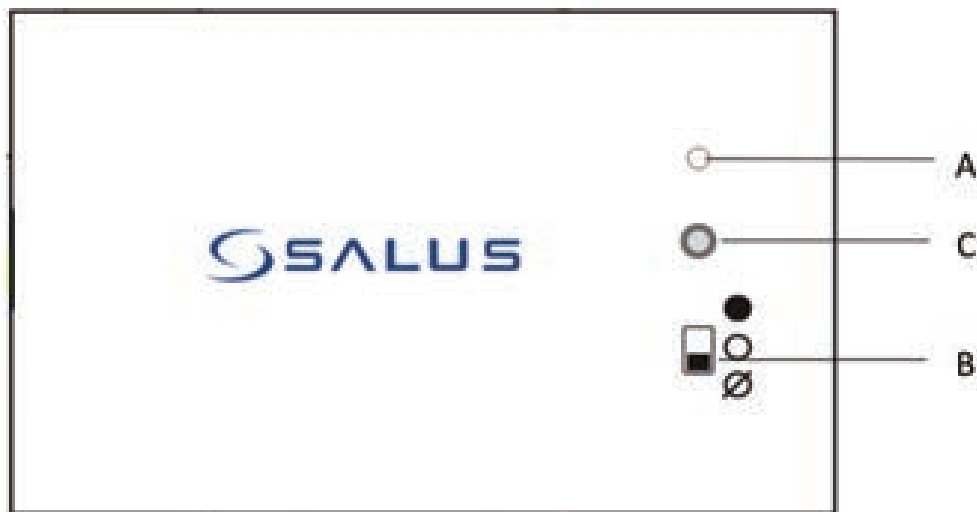

RXWBC605 RECEIVER

INTRODUCTION

The RXWBC605 comprises of an integral plug-in RF boiler control. The RF boiler control is a direct replacement for the basic time clock or blanking plate usually supplied with the boiler. Installing the RF boiler control takes minutes. Once installed, you will benefit from all the control features of the Salus thermostat.

INTEGRAL RF BOILER CONTROL

The Integral RF boiler control is the RF receiving unit for your thermostat. This unit uses a plug-in connection to connect directly to your boiler and provides the ON/OFF switching.

Features

- LED status indication
- Plug-in connection to boiler
- 3 position switch
- 868 MHz communication



RF Transmission

The receiving range between your thermostat and the RF Boiler Control is around 100 metres in open air, however many factors can affect the RF transmission and shorten the operating distance, e.g. shielding by thick walls, foil back plasterboard, metal objects such as filing cabinets, general RF interference, and so on. The operating range is generally around 30 metres, which is large enough for most household applications.

Mounting the RF Integral Boiler Control to the boiler

DANGER!

- **24V & 230V: Do not Touch Electrical Components or circuits.**
- **Isolate mains electricity supply before starting any work and observe all relevant safety precautions.**
- **Follow electro static discharge precaution. Do not touch any visible PCB parts or components.**

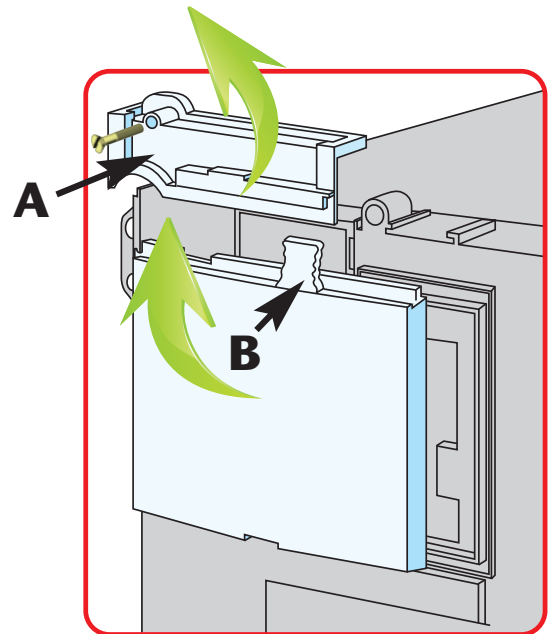

1. Switch off the boiler at its main supply. Remove the outer casing and front fascia to allow access to the main control panel.
2. Remove cover panel A upwards to remove.
3. Pull top tab B upwards, then outwards to remove blanking plate or existing control.

4. First plug in the connector block C ensuring correct orientation. Remember to ensure the block is fully connected.

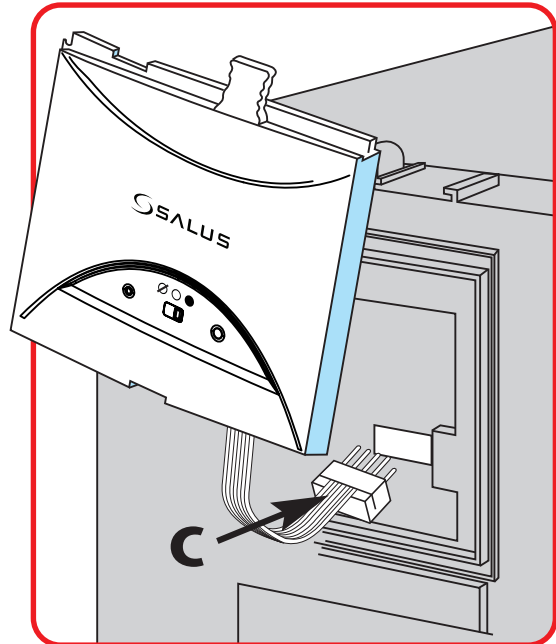

5. Now locate the boiler control's four hooks then press in and down. Replace Cover panel A.

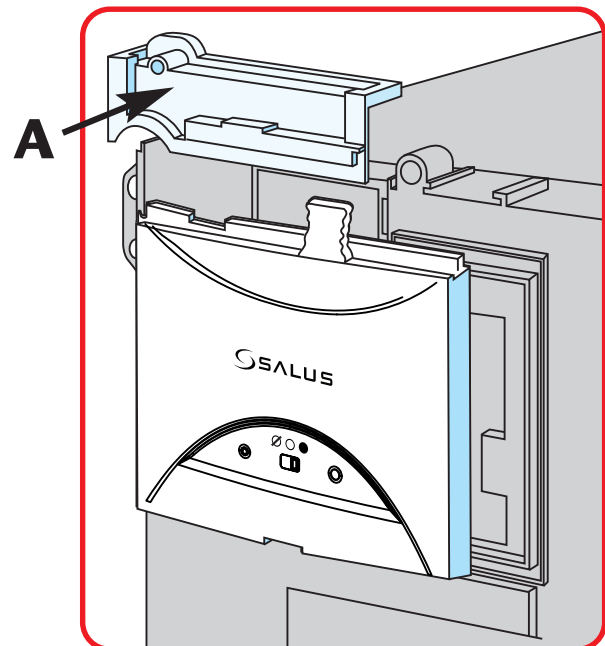

6. Replace the front fascia and boiler's outer casing

7. Before switching the boiler on at its mains supply, ensure the module switch is in the OFF position \emptyset .

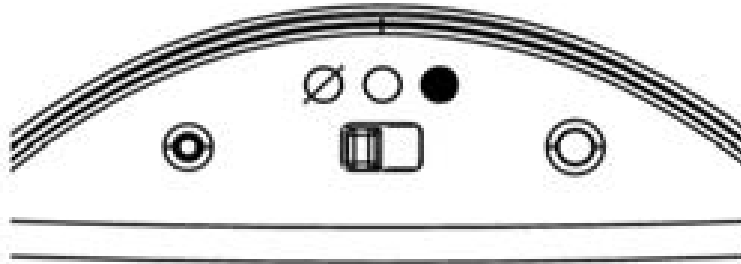

8. To ensure the boiler control is connected properly, please now move the switch to ON \bullet . The boiler should now Fire and the LED on your boiler control should illuminate

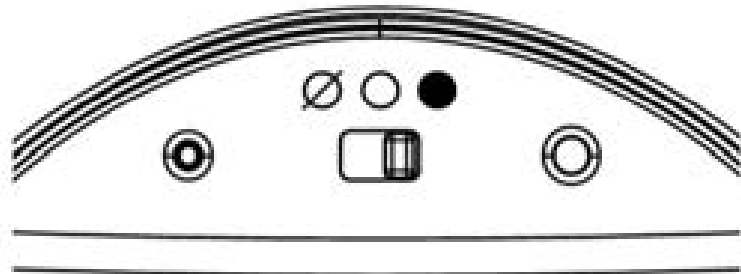

9. Now move the switch back to AUTO \circ .

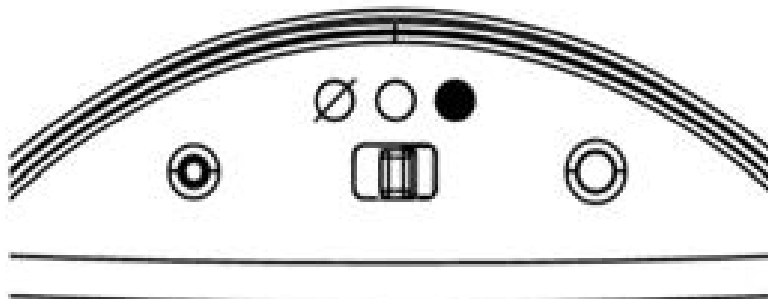

RF Boiler Control

When the switch on the Boiler Module is in the AUTO position, the boiler control will automatically receive the RF signal from the thermostat and control the module output so that it switches the boiler accordingly.

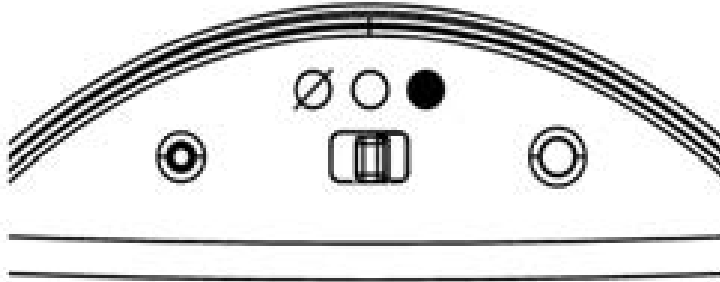

The user can also move the switch to the MANUAL ON position; when in this mode, the boiler will be always turned on and the LED indicator will also be lit constantly.

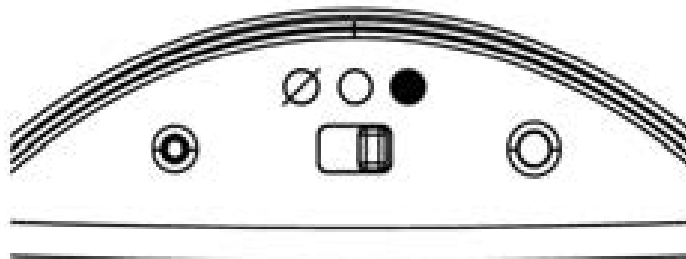

The user can also move the switch to the OFF position; when in this mode, the boiler will not receive a signal from the RF thermostat and the LED indicator will also be lit constantly.

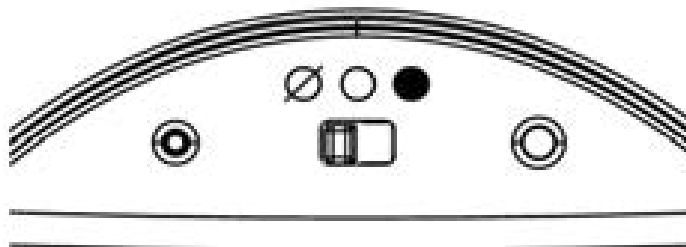

USER CONTROLS

Integral RF Boiler Control

A – LED This LED will be on when the thermostat is demanding heat.

B – Mode Switch ON – Boiler will be on continuous AUTO – will follow time and temperature program in the transmitter
OFF – Boiler is off

C – SYNC Button - This is used only for pairing the RF communications.

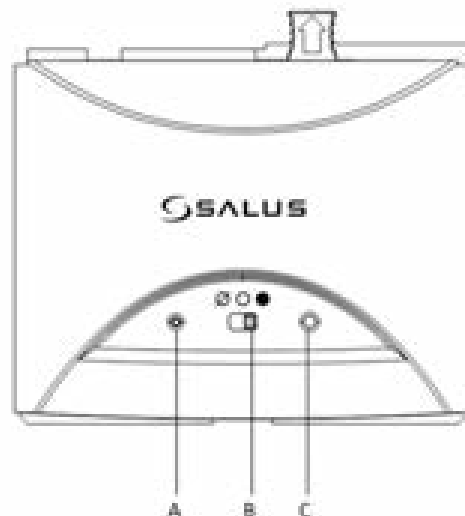

SETTING UP RF COMMUNICATION WITH YOUR THERMOSTAT

If you find that your thermostat will not communicate with integral boiler control please follow the steps below:

1. Ensure the switch on the RF integral boiler module is in the AUTO
2. Gently press and hold the SYNC button with a blunt object. After 3 seconds the Boiler Control LED will flash once every second to indicate it is ready to pair and ready to receive a signal from the thermostat*.

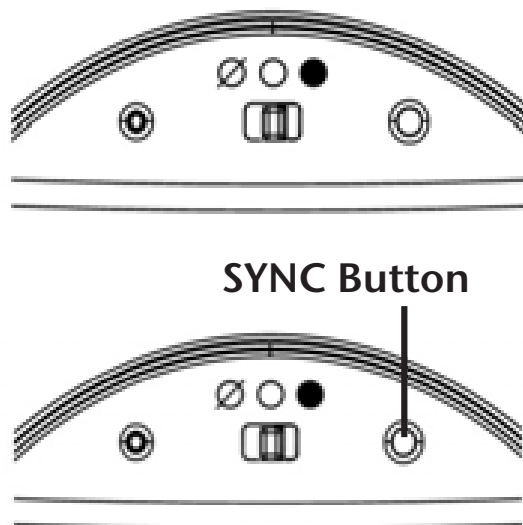

* For full instructions on thermostat pairing see:

RT505TX Manual - Page 13

ST325TX Manual - Page 15

RT305TX Manual - Page 9

ST625TX Manual - Page 11

TECHNICAL SPECIFICATION RXRT505

Radio Frequency (RF) Settings

Operating Frequency: 868 MHz
Max. Operating Range: 100 metres (open air) or
30 metres (indoors)

Environment

Operating Temperature: 0 °C to + 50 °C
Storage Temperature: -20 °C to + 60 °C

TECHNICAL SPECIFICATION RXST625

Model: RXST625
Type: RF receiver, designed for
'Volt Free' applications.

Power Supply – Receiver

Power Source: 230V AC / 50Hz

Switching

Switching Voltage: 230V AC / 50Hz
Switching Current: 16A resistive, 5A inductive
Contact Type: Volt Free

Radio Frequency (RF) Settings

Operating Frequency: 868 MHz
Max. Operating Range: 100 metres (open air) 30 metres (indoors)
Protection rating: IP30

TECHNICAL SPECIFICATION RXVBC605

Radio Frequency (RF) Settings

Operating Frequency: 868 MHz
Max. Operating Range: 100 metres (open air) or
30 metres (indoors)

Environment

Operating Temperature: 0 °C to + 50 °C
Storage Temperature: - 20 °C to + 60 °C

TECHNICAL SPECIFICATION RXWBC605

Radio Frequency (RF) Settings

Operating Frequency: 868 MHz
Max. Operating Range: 100 metres (open air) or
30 metres (indoors)

Environment

Operating Temperature: 0 °C to + 50 °C
Storage Temperature: - 20 °C to + 60 °C

Warranty

Salus Controls warrants that this product will be free from any defect in materials or workmanship, and shall perform in accordance with its specification, for a period of two years from the date of purchase. Salus Controls sole liability for breach of this warranty will be (at its option) to repair or replace the defective product.

Customer Name:

Customer Address:

.....

Post Code: Tel No:

Email:

Engineers Company:

Tel No:

Email:

Intallation Date:

Engineers Name:

Engineers Signature:



www.salus-tech.com

Sales: Email: sales@salus-tech.com Tel: 01226 323961

Technical: Email: tech@salus-tech.com Tel: 01226 323961

Salus Controls plc, Salus House, Dodworth Business Park South,
Whinby Road, Dodworth, Barnsley S75 3SP