



FOBO ULTRA

User Manual

Draft

(For iOS7.1 and Android 4.30 & above)

Contents

- 1 Introduction**
- 2 About FOBO Ultra**
- 3 Importance of Tire Care**
- 4 Product Description of FOBO Ultra**
 - 4.1 In-Car unit/Repeater**
 - 4.2 Tire Sensor unit**
 - 4.3 Sensor lock nuts & wrench**
- 5 Using FOBO Ultra**
 - 5.1 Installing FOBO Ultra App**
 - 5.2 Installing FOBO Ultra In-Car unit and sensors**
 - 5.3 FOBO SHARE - Setting up multiple users**
 - 5.4 Sensor rotation**
 - 5.5 Disable sensor and Replace new sensor**
 - 5.6 Transfer FOBO Ultra to another user**
 - 5.7 How to change profile picture**
 - 5.8 Tire Inflation/Deflation**
 - 5.9 Hook & Drop**
- 6 FOBO Ultra Alert Messages**
- 7 In-Car unit audio & LED alerts**
- 8 Replacing Battery**
- 9 Trouble Shooting Guide**
- 10 FOBO Ultra Specifications**
- 11 Warning**
- 12 Regulatory Information**
- 13 Intellectual Properties**
- 14 Limited Warranty and Disclaimer**

1 Introduction

FOBO Ultra is the world's most advanced Tire Pressure Monitoring System (TPMS) using Bluetooth Smart (Bluetooth 4.1 or later) technology to monitor your Truck, RV, Caravan tire pressure and temperature. Bluetooth Smart is a very low power wireless technology that could operate on a single coin cell battery for up to Fifteen months (**NOTE: Battery life may vary according to usage and climatic temperature. Operating under extreme cold may drastically reduce battery life.**)

Please ensure that your smartphone has Bluetooth Smart Ready (Bluetooth 4.1 or later) capability in order to use FOBO Ultra. Currently FOBO Ultra works best with iOS 7.1 and Android 4.30 or above.

Before starting to use FOBO Ultra, please download the free FOBO Ultra App to your smartphone from Google Play Store or Apple AppStore.

FOBO Ultra is a product designed and produced by Salutica Allied Solutions Sdn. Bhd. ("Salutica"), a Malaysian company with its address at No. 3, Jalan Zarib 6, Kawasan Perindustrian Zarib, 31500 Lahat, Ipoh, and Perak, Malaysia.

2 About FOBO Ultra

FOBO Ultra monitors your vehicle tires non-stop around the clock. Most drivers have encountered situations where they need to rush for an urgent delivery only to be stranded by a flat tire. Conventional Tire Pressure Monitoring Systems (TPMS) could not alert you in advance because it stops operating as soon as the Vehicle ignition is switched-off. With FOBO Ultra, you will get an alert as soon as the tire pressure drops below a certain pre-set level, even when the Vehicle ignition is switched off as long as you are within Bluetooth range (up to 30 meter with line of sight; but the range may reduce by obstacles in between). This alert gives you time to get the flat tire fixed before you need to use it.

FOBO Ultra can monitor up to 20 vehicle profiles on each smartphone. You can receive data from the tire pressure sensors from all your vehicles without switching on the ignition. FOBO Ultra allows you to monitor your Vehicle tires conveniently at any time you want. **NOTE: Under certain conditions the signals from FOBO Ultra sensors may be blocked by surrounding objects or structures. If this occurs, please move around the vehicle in order to capture signals from all the tire sensors.**

If you are sharing your vehicle with others, you (FOBO Sharer) can authorize others (FOBO Sharee) to use your FOBO Ultra through the FoboShare function. After adding them through FoboShare, FOBO Sharees who use your vehicle will

receive alerts and data from your FOBO Ultra on their respective smart phone which is installed with FOBO Ultra App. Refer Details at Section 5.3

FOBO Ultra packaging consists of 4 wireless tire sensors, 1 wireless In-Car unit and a 24V 10 feet power cable with connector to In-Car or Repeater. Replace your vehicle tire valve caps with the sensors and place the In-Car unit inside the cab. The sensors will measure tire pressure of each tire and transmit via Bluetooth to the In-Car unit and your smartphone. In case of a breach of pre-set threshold of tire pressure, the In-Car unit will produce an audible alert to notify you. An alert will also pop up on your smartphone if it is within Bluetooth range.

FOBO Ultra system requires a qualified smartphone and FOBO Ultra App for installation. In addition to being able to view information regarding your vehicle tire pressure and temperature, the FOBO Ultra App will also produce an alert when your tire has a problem.

DISCLAIMER: FOBO ULTRA IS NOT A DEVICE THAT PREVENTS ACCIDENTS. IT IS ALSO NOT A DEVICE THAT PREVENTS TIRES FROM BECOMING DEFLATED OR OVERINFLATED. FOBO ULTRA IS NOT A SUBSTITUTE FOR SAFE TIRE MAINTENANCE PRACTICES. PLEASE CONTINUE TO TAKE PRECAUTIONARY MEASURES WHILE DRIVING AND TAKE FULL RESPONSIBILITY OF YOUR VEHICLE'S TIRE CONDITION TO ENSURE SAFETY WHILE DRIVING. YOU SHOULD CONTINUE TO PRACTICE PROPER TIRE CARE AND SCHEDULED TIRE MAINTENANCE.

3 Importance of tire care

It is extremely important to ensure vehicle tires are properly inflated for safety while driving. However, many drivers tend to neglect proper tire care and maintenance. The vehicle tires are the only contact points between the vehicle and the road. The weight of the vehicle and passengers are supported by the air pressure inside the tires. Improperly inflated vehicle tires may cause serious accidents on the road.

When tires are underinflated, the additional rolling resistance may cause buildup of heat which may lead to the de-lamination of the tire materials as well as damage to the tire's sidewall, which in turn increases the chances of a tire blow-out. Underinflated tires will also cause accelerated wear on the tire shoulders thereby causing uneven tire wear. Gas mileage will also be affected due to additional rolling resistance when driving with underinflated tires. You would also experience a significant loss of steering precision and cornering stability. Significantly under-inflated tires will also be less effective in resisting hydroplaning.

On the other hand, an overinflated tire will cause accelerated wear on the center portion of the tire resulting in uneven tire wear. It would also result in a harsher ride and makes the tire more susceptible to damage when going over potholes or debris on the road.

What is the optimum tire pressure? There are a lot of information about this subject in internet forums and web articles. A quick guide for better understanding of tire pressure below:-

- 1) Vehicle manufacturers recommend the optimum tire pressure for their vehicle models. The information is usually available on a sticker at the door jam (side of the driver's door) or in the owner's manual. For some vehicle models, the information sticker may be on the trunk lid or on the fuel door. Vehicle manufacturers usually recommend different tire pressure for front and rear axles. This pressure is usually recommended for comfort driving and optimum performance of the vehicle. It is not advisable to go below this recommended pressure level.
- 2) The vehicle manufacturer recommended tire pressure is "cold pressure". When you drive your vehicle to the gas station, the friction on the road will heat up your vehicle tires within a few minutes. Typically there will 1 psi (~7kPa) increase in air pressure for every 10 deg F (5.6 deg C) rise in temperature. It is advisable to inflate the tire pressure with this compensated pressure above the recommended pressure.
- 3) Air pressure in tires is affected by changes in temperature. Check and adjust your tire pressure whenever there is a drastic change in environment temperature, e.g. Change of season.
- 4) A tire will normally lose its pressure through natural causes unless accelerated by a puncture, faulty valve or damaged wheels. It is advisable to change the tire valves or at least check the valves condition every time you change a new set of tires. Under normal condition, a set of tires could deflate at a rate of up to 2psi per month. It is good practice to check your tire pressure regularly and top up to the optimum pressure.
- 5) Every vehicle tire has a maximum inflation pressure. It is not advisable to inflate to the maximum inflation pressure of the tire. Follow the vehicle manufacturer's recommended tire pressure instead.

4 Product Description of FOBO Ultra

4.1 In-Car Unit



The functions of three action buttons are to correspond with the instruction that appears on the screen.

NOTE: Excessive frequent pressing on the buttons will drain the In-Car unit battery.

Status indicator	- LED will blink to show Bluetooth pairing mode or battery low status
Alert buzzer	- buzzer to alert when there is problem with tire
AA batteries	- In-car unit/Repeater operates with 5AA size batteries.

The FOBO Ultra In-Car unit/Repeater is a complex device that performs multiple functions. Due to the shielding effect of the vehicle chassis, some drivers may face difficulty in receiving the tire sensor signals on their smartphone when sitting inside the cab. This problem may be further aggravated when the driver places the smartphone in positions that are not optimal such as trouser pocket or waist pouch.

The In-Car unit is designed with an efficient antenna that can pick up sensor signals better than a usual smartphone, enabling good signal reception from the tire sensors. Keep the In-Car unit in the cab and fix the Repeater in the center of the Trailer for optimal functioning of FOBO Ultra. You may remove it for other sensor operation purposes, such as sensor position rotation and sensor disabling but place it back once the sensor operation is completed. Note that In-Car unit is not waterproof.

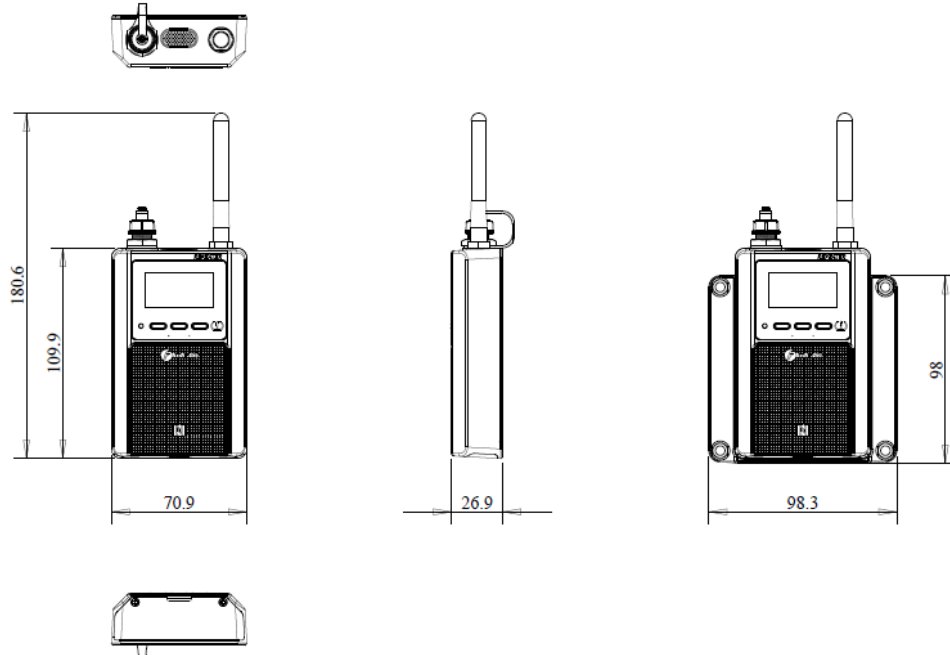

To conserve battery life, the In-Car unit/Repeater will go into ‘sleep’ mode after it detects that the vehicle has been stationary for more than 15 minutes. It will ‘wake up’ once it detects that the vehicle moves. You can still receive your tire pressure and temperature data by accessing the FOBO Ultra App on the smartphone, even when the In-Car unit is asleep. This is due to FOBO Ultra sensor’s continuous operation of 24 x 7 which allows you to receive an alert even when the vehicle’s ignition is switched off.

The In-Car unit/Repeater is also designed to be a secondary alert device in the event of a deflated tire. This is to cover situations when you do not have your smartphone with you while driving or if your smartphone’s battery is dead. When there is a tire pressure alert, the In-Car unit/Repeater will produce an audible and visual LED alerts to inform you of a tire pressure problem.

4.2 Tire Sensor Unit

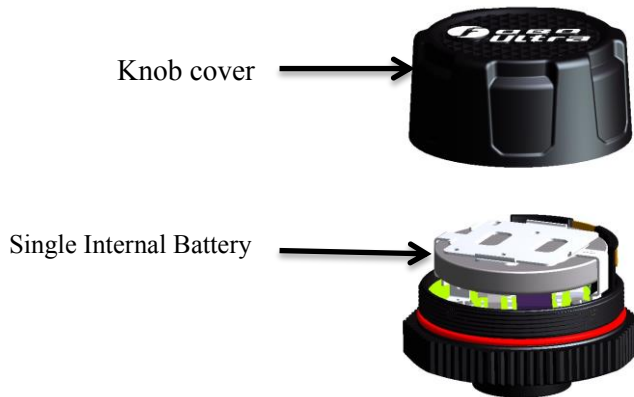

- Knob cover** – waterproof cover. Please ensure the red silicon ring is intact to prevent water from getting into electronics compartment.
- Single internal battery** - CR2032 coin cell battery. When replacing battery, please ensure the “+” sign of the battery is facing up, away from PCB.
- Internal PCB** - internal electronics circuit (The pressure sensor chip is mounted within this PCBA, and it senses the tire pressure against a built-in vacuum, resulting in an Absolute Pressure reading. The internal firmware will then subtract the sea-level pressure of 101.3 Kpa (14.7 psi) from this reading. This final reading which will be shown in the App can be termed as i) Tire **Absolute Pressure minus sea level pressure**, or ii) Gage Pressure reference to sea-level altitude. With this formulation, Fobo Ultra sensor will read the same pressure value for any given time, irrespective of altitude (assuming a constant temperature). This will ensure the correct tire footprint per vehicle manufacturer’s pressure recommendation, for all altitude above sea-level, given a constant temperature.

As a corollary, a tire with a Fobo reading of, say 40 psi at an altitude of 5000ft, will read the same 40 psi when driven to sea-level, given a constant temperature. In reality, it will read higher due to the warmer temperature at sea-level, and may need some air release if the temperature difference is great. Tire pressure generally will increase 1 psi (~7kPa) for every 10 deg F (5.6 deg C) rise in temperature.

FOBO wishes to highlight the above formulation is for usage at sea-level and above, and will not be accurate for use otherwise. In practice, this should not be an issue as the lowest area on earth will result in an insignificant error of 0.3 psi (~2 Kpa).

For users who wish to retain ‘Gage Pressure Reading’, the FOBO Ultra App has a Gage Pressure, adjusted to local altitude using cell towers or individual phone barometer if available. This Gage Pressure button can be accessed from the App (Kindly refers to Section 5.10 of this user manual).

FOBO Ultra sensor units are designed to be robust and operate reliably 24x7 to provide tire information around the clock. It is designed to be water proof (IP57) and by our special use of custom engineering plastics, it will be able to withstand road salts or other common automotive chemicals (petrol, engine oil, wash shampoo, etc.).

Our designers have designed the sensors to ensure that there is no air leakage as it replaces the tire’s original valve cap. There is no need to screw on the sensor extremely tight. Apply a reasonable hand twist force to ensure the sensor is securely installed and should be able to be removed by hand with ease.

When installing the sensors, please follow the on-screen prompt of the In-car unit. After installation, in the event the tire sensors positions are mixed up, usually after performing a tire rotation maintenance, you can easily re-position the sensors to their correct position by selecting ‘sensor rotation’ on the in-car unit and follow the on-screen instructions. This eliminates the need to remove the tire sensors physically.

A missing or damaged tire sensor can be replaced easily through the In-car unit. You will need to purchase a replacement sensor which you can do so online at www.my-fobo.com. To replace the sensor, first select 'Disable Sensor' on the In-car unit under sensor Management system and the pop-up will prompt you to tap on the tire position that you want to disable. Then, select 'Replace sensor', upon selecting the app will blink at the first disabled position and the App will prompt you to install the replacement sensor. Follow the on-screen instruction and the replacement sensor will be paired and be ready to use.

NOTE: Battery life span up to Fifteen months is an estimate based on normal use at 23 °C. Battery life may vary according to usage and climatic temperature.

Battery life span will change due to the following reasons:

- 1) Frequent change of pressure threshold setting in the App.
- 2) Disabling & enabling of sensors.
- 3) Release & pairing.
- 4) Removal & screw-on of sensors.
- 5) Operating under extreme cold/hot temperature.
- 6) Testing of product.
- 7) Rotation (refer section 5.4 of this user manual)
- 8) Trigger alert or let activated alerts unattended.
- 9) Multiple removal and screw-on of sensors for equalizing all tire pressures.

All these activities will drain a battery very fast and affect the battery life span.

4.3 Sensor Lock nuts and wrench



FOBO Ultra sensors and In-Car unit are tied to a FOBO account after installation. They are not re-usable or transferable without the owner releasing them from his/her FOBO account. This is a theft deterrent feature to discourage theft.

As an additional anti-theft feature, all FOBO Ultra package comes with lock-nuts and special wrench. FOBO Tire Plus's functionality is not affected if you do not use the lock-nuts.

The lock nuts and wrench are made of custom engineering plastics that can withstand road salts and common automotive chemicals (gasoline, engine oil, wash shampoo, etc.).

In order to use the lock nuts, you must first install the lock nut to the tire valve (with the bump facing tire rim). Screw in the lock nut all the way down and ensure that there is still a **minimum of 5 thread count** on the tire valve for the sensor unit to be screwed on. If there is insufficient thread for the tire sensor, it may lead to air leakage. A solution for this would be to change the tire valve to one with a longer thread. Next, screw in the tire sensor unit until it is reasonably tight. Then use your finger to unscrew the lock nut outwards (i.e. anti-clockwise) until it pushes against the bottom of the sensor unit. Use the wrench to tighten the lock nut. The resultant friction force will make it difficult to remove the sensor unit without loosening the lock nut. For rubber valves, hold the valve stem with one hand and tighten the lock nut with the wrench on another hand. This is to avoid the rubber valve from twisting making it unable to tighten the lock nut.

WARNING: Do not apply too much force to tighten the lock-nut. You may face difficulty to loosen the lock nut later on especially for rubber valves that typically doesn't stay firm on the tire rims.

NOTE: If your tire valve is too short, you shouldn't use the lock nut as this will block the sensors from being completely screwed on the tire valve and causes air leak. Our sensors are designed to work on a tire valve with a minimum of 5 thread counts.

Step by step diagram to use FOBO Ultra Lock Nut and wrench

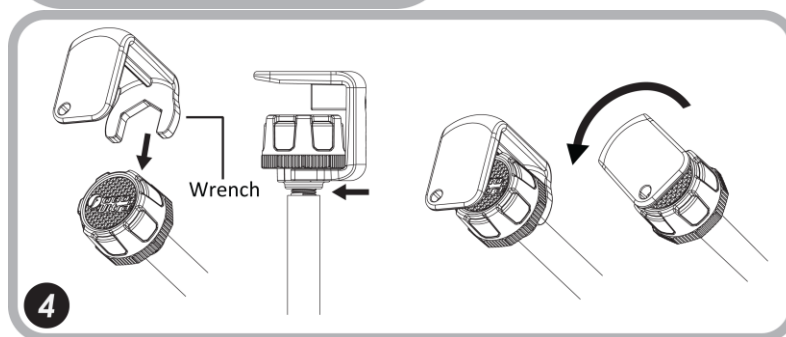
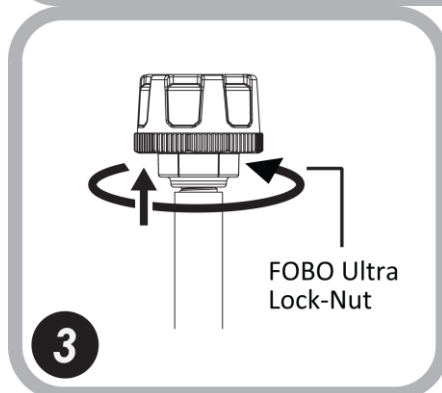
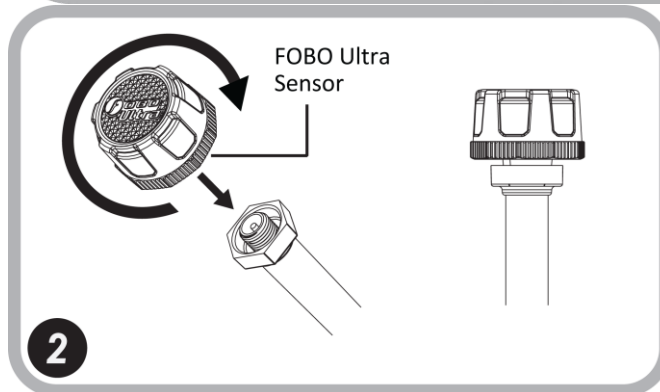
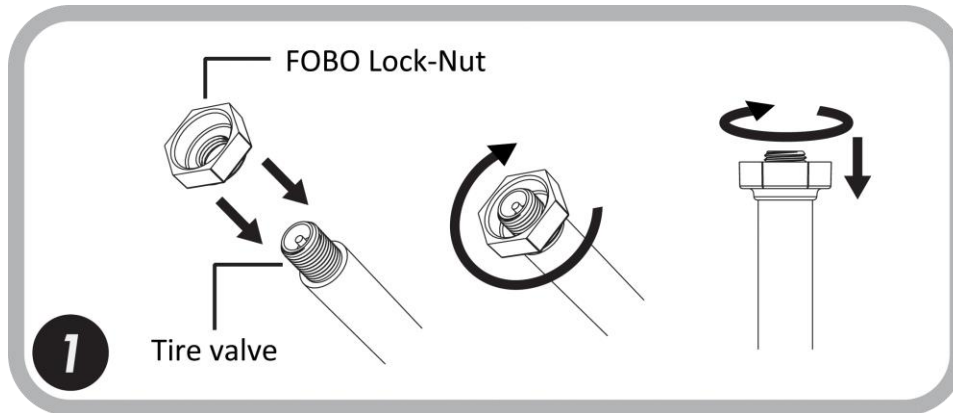

5 Using FOBO Ultra

5.1 Installing FOBO Ultra App

You are required to have a smartphone with **Bluetooth 4.0** (Bluetooth Smart) capability in order to use FOBO Ultra. The smartphone must also be running on iOS 7.1 or Android 4.3 and above. Follow the steps below to install your FOBO Ultra:

Step 1: Download the FOBO Ultra App onto your smartphone

- For iPhone users, download from Apple's AppStore. For Android users, download from Google Play. Search for "FOBO Ultra".

Step 2: Launch the FOBO Ultra App & key in your email address

- For new users, key in your email address and click login.
- You will receive an email from FOBO with an activation link.
- Click on the activation link that you receive in your email.
- Once activated, go back to the FOBO Ultra App and click on login again.
- You be brought to the App's Home screen.

Note:-

- An activation e-mail message will be sent to your e-mail address when you click on login as a first time user.
- If you do not receive this activation e-mail from FOBO Admin, please check your e-mail address entry to ensure it is valid without typo error.
- This e-mail may also be filtered by some e-mail servers. Please check your Spam mailbox.
- If you still do not receive any message from FOBO Admin after 15 minutes (with a good internet connection), please write in to fobo@salutica.com.my with your sign-in email.

IMPORTANT:

The email activation is to ensure that your account signup is done securely. FOBO Ultra is locked to your FOBO account as an anti-theft deterrent. Stolen sensors cannot be used by anyone else other than the FOBO account owner.

Location service is required to be enabled for the FOBO Ultra App (FOBO Ultra does not use the GPS function to track your location). The location service on the iOS/Android system has other functionality that

the FOBO Ultra App uses to operate properly and to sync with the In-Car unit. It will ensure FOBO Ultra functions as designed, mainly for alert functions, and also the gauge pressure feature as required by users living at high altitudes. FOBO Ultra is designed to be a low energy system and does not drain your smartphone battery excessively.

By submitting your information to sign up a new user account, you acknowledge your acceptance to the terms and conditions of our Software Licensing Agreement and Privacy Policy.

5.2 Installing FOBO Ultra In-Car unit & sensors

TO REDUCE THE RISK OF AN ELECTROSTATIC DISCHARGE (ESD) PLEASE TOUCH THE WHEEL WHEN SCREWING ON THE TIRE SENSOR ON TO THE TIRE VALVE. THIS IS TO MINIMIZE POTENTIAL ESD ATTACK WHICH MAY CAUSE DAMAGE TO THE TIRE SENSOR AND ITS FUNCTION.

INSTALLING FOBO ULTRA SETS ON MORE THAN ONE VEHICLE WHICH ARE PARKED CLOSELY TOGETHER MAY CAUSE CROSS INTERFERENCE TO THE BLUETOOTH SIGNALS. PLEASE INSTALL FOBO ULTRA ON ONE VEHICLE AT A TIME.

To begin using FOBO Ultra, firstly ensure that the FOBO Ultra App is downloaded and you have already login to the App (see section 5.1 above for installation and login).

Follow the steps below to pair FOBO Ultra to your smartphone:-

- 1) Turn on your smartphone's Bluetooth connection.
- 2) Set the FOBO Ultra's In-Car unit/Repeater into 'pairing mode' by long press "SELECT" to start pairing.
- 3) Open FOBO Ultra App.
- 4) Follow the on screen instruction on FOBO Ultra APP.
- 5) Key in the name you would like to identify your Vehicle.
- 6) Tap on the profile picture box and take a picture of your vehicle.
- 7) Select the vehicle manufacturer recommended tire pressure for all the axles. The information is usually available on a sticker at the door jam (side of the driver's door) or in the owner's manual. For certain vehicle models, the information sticker may be on the trunk lid or on the fuel

door. You cannot proceed with the pairing without the input of this information into the FOBO Ultra App.

- 8) Click “Done” on the top right hand corner of the screen.
- 9) Select “sensor installation” under Main Menu of In-Car unit and follow the instructions on screen of the In-Car unit.
- 10) You will be prompted that installation is completed and you are now ready to use FOBO Ultra.



CAUTION:

Motor vehicles of all kinds (caravan, trucks, RV and Trucks come with a very wide array of rims, wheels, and tires, with an even larger choice of aftermarket products. It is impossible for us to test every combination and check the fitment of the FOBO Ultra sensor. In some instances, when the FOBO sensor is screwed onto the valve stem, it might extend slightly beyond the face of the rim/wheel. If the rim/wheel comes close to or strikes an object, such as a curb, a pothole, the guide rail for an automatic vehicle wash, or a component on the vehicle, the FOBO sensor or the valve stem itself might become damaged. This can cause the FOBO to provide improper readings, or might cause a loss of air pressure. We recommend that you carefully assess the fitment of your rims, wheels, tires and the FOBO on your vehicle. If you have any concerns, consult with your tire shop or auto mechanic. A shorter valve stem might be considered to mitigate the situation.

5.3 FOBO SHARE- Setting up multiple users

FOBO Ultra is easy to share with your family members and friends. You can share FOBO Ultra with up to 100 users by using the App's FoboShare function. All that is required is for the other person to download the FOBO Ultra App (they will also need an iOS/Android smartphone with Bluetooth 4.0 that is running on iOS7.1 or Android 4.3 and above). They need to activate their App with their email and login to the App.

Follow these steps to share your FOBO Ultra with other users:-

1. Ensure that the user receiving the sharing (recipient) has downloaded the FOBO Ultra App and has activated their App with their own email address.
2. Ensure that the recipient's smartphone has their Bluetooth connection turned on.
3. On your Vehicle status screen, click on the settings icon and select 'FoboShare'.
4. Click on the "+" sign at the top right corner of the App.
5. Type in the recipient's email that was used to activate their App.
6. Your vehicle profile will appear on the recipient's App with a "FoboShare" logo.
7. The recipient clicks on your vehicle profile and he will start to receive all the data from the FOBO Ultra sensors on his smartphone when he is within Bluetooth range.

NOTE: Please ensure good internet connection for FOBO Ultra App to connect to the cloud.

Note that shared users will not be able to change settings (name, user limits, etc.) on your FOBO Ultra set. They can only view the readings and receive alerts. At the FOBO Ultra's App HOME page, a shared vehicle will depict a "FoboShare" logo at the bottom of vehicle profile image to distinguish a shared vehicle from your own vehicle.

5.4 Sensor rotation

It is good practice to rotate your tire positions regularly to balance the thread wear of your tires, usually swapping the front tires with the rear tires. FOBO Ultra is designed to conveniently set the sensors to their correct tire position in the in-car unit after you have swap your tires on your vehicle. You do not

need to physically remove the sensors. To correct the position of the sensors in the in-car unit, please select “sensor Rotation” under Main Menu on in-car unit. You will be prompted by the in-car unit to:

- 1) Select the sensor position to rotate. Move to the desired position to select the sensor by using the arrow key which is in the middle of the in-car unit/Repeater.
- 2) Upon selection, you will be prompted to touch the sensor to the in-car unit /Repeater.
- 3) There will be an audible sound with a message to indicate successful registration of new position.
- 4) Choose NEXT to go to another tire position to rotate.
- 5) Choose END to complete the rotation process.

You are now ready to use FOBO Ultra with the new tire positions. You can perform tire rotation as often as you want.

5.5 Disable sensor and Replace new sensor

You may want to disable a sensor due to a missing sensor or damaged sensor or to install a replacement sensor. Disabling a missing or damaged sensor will remove future missing sensor alerts.

To disable a tire sensor:-

1. Go to Sensor Management in the Menu of In-Car/Repeater, select “Disable sensor”.
2. Select the tire position in the screen to disable.
3. Once disabled You will see “Sensor Disabled” message will appear on the screen. Take note that FOBO Ultra will stop monitoring the disabled sensor position.

To install a replacement tire sensor:-

1. Select “Replace sensor” under Sensor Management in the Menu of In-Car/Repeater.
2. The first disabled position will be blinking.
3. Move to the desired disabled position to assign a replacement sensor.
4. Select the tire position to replace.
5. You will be prompted to touch the sensor to the in-car unit.

6. Once replaced you will see “Sensor is successfully replaced..”. Please mount the sensor to the physical tire position in accord with the screen message.

NOTE: You can only install a replacement sensor after the tire position has been “Disabled”. You can purchase replacement sensors online from www.my-fobo.com.

5.6 Transfer FOBO Ultra to another user

Before passing on your FOBO Ultra set to another user, you will have to release the Total system from your FOBO account. Select “Release (Total sensor)” under Main Menu on in-car unit then “Release total system”.

Make sure your In-Car unit and smartphone are with you. You will be prompted with a message to “Select PROCEED to continue and follow the instruction on the phone App”, upon selecting PROCEED; the In-Car unit will connect to the smartphone. You will hear an audible sound upon successful release and “System released” message will appear on in-car unit screen.

5.7 Tire Inflation/Deflation

To Inflate/Deflate the tire user just need to unscrew the sensor, inflate/deflate the tire then screw back the sensor on tire valve. User do not need to release or disable the sensor.

5.8 Hook & Drop

With its patent pending F.I.T (FOBO Intra Connect) technology, FOBO Ultra System offers Hook & Drop for easy attachment and detachment of trailers to prime mover. F.I.T. enables harvesting of sensor data by clusters of individual sensors and then transmits the data amongst inter-connected clusters to the In-Car unit. FOBO Ultra system can display up to 94 wheel positions with a combination of 1 In-Car + 3 Repeater clusters. For example, for a prime mover that hauls 3 trailers, FOBO Ultra allows 1 In-Car unit for the prime mover and 3 repeater units for the 3 Trailers. 1 In-Car unit can monitor up to a cluster of 22 sensors while each Repeater unit can monitor up to a cluster of 24 sensors. Each Repeater unit can be independently controlled, programmed and monitored.

To HOOK a trailer:

1. Select “Hook & Drop” in the Main Menu of In-Car unit.
2. Select “Hook a trailer”.
3. Upon selecting, the in-car unit will scan for available trailers nearby in Bluetooth range.
4. List of available trailers will be displayed on the in-car unit screen.
5. Select the desired trailer from the list which you would like to Hook.
6. To confirm press “Yes”.
7. Once hooked you will see “Hook successful” message will appear on the screen.

To DROP a trailer:

1. Select “Hook & Drop” in the Main Menu of In-Car unit..
2. Select “Drop a trailer”.
3. List of *hooked* trailers will be displayed on the screen.
4. Select the desired trailer from the list which you would like to Drop.
5. To confirm press “Yes”.
6. Once dropped you will see “Drop successful” message will appear on the screen.

6 FOBO Ultra Alert Messages

You will get the following alert messages below on your smartphone during the operation of FOBO Ultra under different conditions. The In-Car unit/Repeater will also generate different alert tones to distinguish the severity of the alert. When you get a continuous non-stop two-tone alert, please find a safe location to stop your car and check the alert messages on the smartphone.

A. Soft Alert – In-Car unit will beep 5 tone alert every 5 minutes for 15 minutes –

6.1 Pressure below preset limit

You will receive this soft alert when the tire pressure drops below the pre-set lower limit. The pre-set value for the low limit is 8% below the recommended pressure that you have set or below 160kPa, whichever that is higher. You can change this lower limit in the advance setting down to a minimum of 160kPa (1.6 bar/23 psi). For fuel economy and optimum tire performance, it is recommended to maintain this 8% range so that you can keep your tires inflated optimally. If you find the reminder is too frequent, you may want to check your tire for any leakage. Note that drastic temperature drop may also cause tire pressure drop. Please check your tire pressure and re-inflate during change of seasons.

Note: The hard limit for low pressure is fixed at 160kpa (1.6bar/23psi) and cannot be change by the user.

6.2 Pressure above preset limit

You will receive this soft alert when the tire pressure increases above pre-set upper limit. The pre-set value for upper limit is 25% above recommended pressure or above 1296kPa (188psi), whichever that is lower. You can change this upper limit in the advance settings up to a maximum of 1296KPa (188 psi). For optimum tire performance and grip, you should not overinflate your vehicle tires. Note that the tire pressure will naturally increase as the vehicle tires heat up due to friction while driving. However, you should check your tire in the event of an abnormal rise in the tire pressure.

Note: The hard limit for high pressure is fixed at 1986kpa (188 psi) and cannot be change by the user.

6.3 Sensor battery level low

You will receive this soft alert when the sensor battery level drops to certain level. Please change the battery immediately after you receive this alert. You will continue to receive this alert every time you start moving your vehicle until the battery is changed.

6.4 In-Car unit/Repeater battery level low

You will receive this soft alert when the In-Car unit/Repeater reaches a certain low level. Please change the battery immediately after you receive this alert. You will continue to receive this alert every time you start moving your vehicle until the battery is changed.

B. Emergency Alert – In-Car unit/Repeater it will beep continuously non-stop with a two tone alert every 3 seconds for 15 minutes.

6.5 Pressure too low

You will receive this emergency alert when the tire pressure drops 15% below the recommended pressure that you set or when the tire pressure is below 160kPa (1.6 bar/ 23psi), whichever that is higher. **NOTE: IT IS DANGEROUS TO DRIVE WITH LOW TIRE PRESSURE AND IT MAY LEAD TO A BLOW-OUT. PLEASE STOP THE VEHICLE AND HAVE THE TIRE CHECKED WHEN YOU RECEIVE THIS ALERT.**

6.6 Pressure too high

You will receive this emergency alert when the tire pressure is 35% above the vehicle tire recommended pressure that you set or when the tire pressure is above 1296kPa (188psi), whichever that is lower. **NOTE: THIS IS AN ABNORMAL RISE IN THE TIRE PRESSURE. PLEASE STOP THE VEHICLE AND HAVE THE TIRE CHECKED WHEN YOU RECEIVE THIS ALERT.**

6.7 Temperature too high

You will receive this emergency alert when the temperature detected exceeds 65°C/149°F. Note that the temperature inside the tire may be higher than the temperature detected by FOBO Ultra sensors due to the air cooling effect on the tire valve when the vehicle is moving. It is extremely dangerous to drive when you get this alert message. **WARNING: WHEN YOU RECEIVE THIS ALERT, PLEASE STOP YOUR VEHICLE IMMEDIATELY AND CHECK THE TIRE!**

6.8 Signal low or sensor missing

You will receive this emergency alert when the In-Car unit/Repeater fails to communicate with the tire sensor. It could be the sensor signal is blocked, sensor unit damaged or missing from the tire. If confirmed the sensor is damaged or missing, you could disable the sensor in order to continue using FOBO Ultra with remaining working sensors. Please purchase the sensor replacement immediately. It is not advisable to continue driving without FOBO Ultra actively monitoring one or more of your vehicle tires.

6.9 Pressure Drop too fast

For fast air leak, FOBO Ultra smartly alerts the user when it matters the most. FOBO sensors sense the pressure every **8 seconds**, if the pressure changes more than **15 Kpa** OVER this time frame, the sensor will immediately send an updated pressure signal to the phone which will trigger an alert on the FOBO Ultra App in the event the pressure has breached the upper or lower limit (Applicable to all 3 alert levels).

If there is a sudden drop in pressure (**say from 200 Kpa to 0 Kpa**) in **LESS than 8 seconds**, the App will not alert you because the App will treat this as though you have removed the sensor to inflate your tire. The system is designed this way as we believe that if there is an instant drop to 0 pressure, the user would have already felt it before getting any alert from the TPMS (like getting a burst, or hitting a kerb/drain, etc.)

7 In-Car unit/Repeater audio & LED alerts

The In-Car unit/Repeater will produce different tones and LED flashes for different situations. For repetitive alerts, you can stop the alerts by pressing the In-Car unit side button once. In case you have forgotten the location of the problematic tire, you can short press the side button another time to re-produce the alert one time.

Wake up – unit will produce “di da” tone once with LED blinking sequentially for all four tire indicators. This shows that In-Car unit is awake and operational.

Sleep – unit will produce “daaa” tone once. No LED blink. This shows In-Car unit is going to sleep and not operational. In-Car unit goes to sleep to conserve battery when vehicle is not moving for a long time. However the sensors will still be operational 24x7 and continue to monitor and alert to your smartphone in case of flat tire.

Soft alert – unit will produce “di di di di di” tone once and repeat every 3 minutes. LED will blink for 5 seconds on problematic tire. This alert is for non-emergency situation such as:-

- Tire pressure slightly exceed above or below user pre-set limits. It is not dangerous to continue driving.
- Sensor battery low. Once notified on low sensor battery, please remember to change the battery as soon as possible. Do not leave the unit to continue operating under low battery for a long time.
- In-Car unit battery low. LED blink will be on the status LED, not on the tire indicator LED. Once notified on low sensor battery, please remember to change the battery as soon as possible. Do not leave the unit to continue operating under low battery for a long time.
- Signal low or sensor missing. For this situation, the tone will repeat every 5 seconds instead of 3 minutes to inform user of a possible missing sensor.

Emergency alert – unit will produce “di da di da di da” tone once and repeat every 5 seconds. LED will continue to blink on problematic tire. This alert is for emergency situation such as:-

- Tire pressure is too high or too low. It is not recommended to continue driving without checking the condition of the tire. Please stop the vehicle at a safe location to check the condition of the tire.
- Tire temperature is too hot, exceeding 65°C or 149°F. It is not recommended to continue driving without checking the condition of the tire. Please stop the vehicle at a safe location to check the condition of the tire. Note that the measured temperature may be lower by 10°C or 50°F compared to the actual temperature of the air inside the tire when the vehicle is moving, due to the cooling effect on the tire valve.

WARNING: FOBO ULTRA IS A MONITORING DEVICE TO ALERTS THE USER WHEN IT DETECTS SIGNALS THAT IS OUT OF PRE-SET CONDITIONS BASED ON THE SETTING BY THE USER. THE USER OR DRIVER IS SOLELY RESPONSIBLE TO FIND OUT THE ACTUAL CONDITION OF THE TIRE AND TO ENSURE PROPER TIRE MAINTENANCE. FOBO ULTRA IS NOT RESPONSIBLE FOR WRONG DIAGNOSTICS OR FALSE ALERTS THAT MAY CAUSE INCONVENIENCE.

8 Replacing Battery

The coin cell battery (CR2032) used in the FOBO Ultra sensors could last up to fifteen months based on normal operating condition. Operating in extreme cold or hot temperatures may reduce battery operating life for both the tire sensors and the In-Car unit.

You will receive an alert on the smartphone and In-Car unit/Repeater when the sensor or In-Car unit/Repeater battery levels are low. You will be alerted every time you start to drive your vehicle until the battery is replaced. It is advisable to change the battery once you receive this battery alert to ensure proper performance of FOBO Ultra. Do not wait until the battery is fully drained as it will cause FOBO Ultra to stop working properly.

To replace the battery of sensor unit, unscrew the top cover. Be careful not to damage the rubber gasket as it may affect water resistance of the sensor unit. Ensure the battery (CR2032) is inserted with the “+” sign facing up, away from the PCB.

To replace battery for the In-Car unit, slide out the battery cover. Ensure the battery (AA) is inserted in the correct orientation. It is advisable to use good quality AA batteries (recommended Lithium or Alkaline) for longer lasting performance of In-Car unit.

WARNING: RE-USING OLD BATTERIES OR MIXING OLD AND NEW BATTERIES IN THE IN-CAR UNIT MAY DAMAGE THE ELECTRONICS.

9 Trouble Shooting Guide

- Could not sign up a new FOBO account (did not receive activation e-mail)
 - Check the e-mail address entry is typed correctly
 - Check the Spam mailbox, in case the e-mail was filtered by the e-mail server
 - Check the smartphone is connected to internet and able to receive e-mail

- Could not sign up a new FOBO account (received activation e-mail)
 - Make sure to click on the “Activation” link of the latest e-mail, in case there are multiple authentication e-mails
 - You should be directed to web page that clearly displayed “FOBO account is activated”.

- Unable to Login after signing up to FOBO App
 - Make sure your e-mail address is typed correctly
 - A verification mail will be sent to your e-mail address
 - Follow the instruction in the mail to activate your account before you can Login
 - Check if internet connection is available on your smartphone

- Unable to pair FOBO Ultra In-Car unit/Repeater
 - Make sure the battery is installed correctly and battery tab is removed.
 - Make sure your smartphone has Bluetooth 4.0 or later (Smart Ready) capability. **NOTE: BLUETOOTH 2.0 OR 3.0 WILL NOT WORK WITH THIS DEVICE.**
 - Please check if the FOBO Ultra has been paired before to another FOBO account. You'll need to "Release" the FOBO Ultra set from the FOBO account that it is paired to, before using on your account. The FOBO Ultra is designed to pair with one FOBO account only for theft deterrent feature.
 - Try to reset the Bluetooth manager of your smartphone (for iOS: Settings-> Bluetooth-> OFF->ON). At times the Bluetooth manager may be disrupted which may require manual reset.
 - Try to do a hard reset on the phone.

- Unable to pair FOBO Ultra sensors
 - Make sure the sensor is screwed onto a tire valve with pressure above 100kPa
 - Try unscrew the sensor from tire valve, screw it back and try again
 - Make sure the battery is installed correctly with battery "+" on top.
 - Make sure your smartphone has Bluetooth 4.0 or later (Smart Ready) capability. **NOTE: BLUETOOTH 2.0 OR 3.0 WILL NOT WORK WITH THIS DEVICE.**
 - Try to reset the Bluetooth manager of your smartphone (for iOS: Settings-> Bluetooth-> OFF->ON). At times the Bluetooth manager may be disrupted which may require manual reset.
 - Try to do a hard reset on the phone.

10 FOBO Ultra Specifications

Sensor Specifications:

- Maximum Pressure 1296 Kpa (188 psi)
- Pressure Accuracy:
 - 1 σ = +/- 0.79 psi (0 to + 50 °C)
 - 1 σ = +/- 1.06 psi (-40 to + 85°C)
- Temperature Accuracy:
 - 1 σ = +/- 1 °C (0 to + 50 °C)
 - 1 σ = +1.33 / - 1°C (-40 to + 85°C)
- Operational temperature range: -40 to 85°C
- Up to 15 months battery life CR2032
- Dust protected & Waterproof : IP57
- Light weight sensors. Only 12.6 g each
- Certification: FCC, CE, BQB and RoHS
- Mechanical & Environmental Reliability Testing Standards: IEC 60068-2-2, IEC 60068-2-1, IEC 60068-2-29, IEC 60068-2-5, IEC 60068-2-32, ISO 15184, ISO 2409, SAE J2848 , SAE J1455
- Bluetooth 4.1 (Compatible with Bluetooth 4.0 or later)
- Compatible with iOS 7.1 or Android 4.3 or later

In-Car / Repeater Specifications:

- Operational temperature range: -40 to 80°C
- Battery life: up to 12 months
- Power source: Battery AA x 5 pcs or 12V to 24V external supply
- Operating Temperature
 - With vehicle power source: -40°C ~ +85°C
 - With Alkaline batteries: -18°C ~ +50°C
- Storage Temperature:
 - Without Alkaline battery: -40°C ~ +85°C
 - With Alkaline battery: -30°C ~ +45°C
- Weight : 100g (without battery)
 - 220g with 5x alkaline batteries
- Dust protected & Waterproof : IP57 (Repeater only)
- Certification: FCC, CE, BQB and RoHS

- Mechanical & Environmental Reliability Testing Standards: IEC 60068-2-2, IEC 60068-2-1, IEC 60068-2-29, IEC 60068-2-5, IEC 60068-2-32, ISO 15184, ISO 2409, SAE J2848 , SAE J1455
- Bluetooth 4.1 (Compatible with Bluetooth 4.0 or later)
- Compatible with iOS 7.1 or Android 4.3 or later
- NFC

11 Warning

- Take note that FOBO Ultra is not meant to function as anti-accident or anti-injury device. FOBO Ultra is not a substitute for safe tire maintenance practices. Please take full responsibility of your own safety while driving. And continue to send your car for regular tire check and maintenance.
- Please take extra precaution to acoustics safety when operating the FOBO Ultra In-Car unit. Note that placing the FOBO Ultra In-Car unit beeper close to your ear may result in injury to the ear or permanent loss of hearing.
- You shall not use the FOBO Ultra in any unlawful way that violates any laws.
- Avoid exposing the FOBO Ultra In-Car unit and sensors to solvent, fire or extreme temperatures.
- FOBO Ultra may fail to function properly if the battery is below optimum level. Replace the battery immediately to continue enjoying full features of FOBO Ultra.

CAUTION

THERE MAY BE A RISK OF EXPLOSION IF BATTERY IS REPLACED BY AN INCORRECT TYPE. DISPOSE ALL USED BATTERIES PROPERLY.

12 Regulatory Information

Federal Communication Commission Interference Statement

This device (FCC ID: PTP-TU1601) complies with Part 15 of the FCC Rules. Operation is subject to the following two conditions: (1) This device may not cause harmful interference, and (2) this device must accept any interference received, including interference that may cause undesired operation.

This equipment has been tested and found to comply with the limits for a Class B digital device, pursuant to Part 15 of the FCC Rules. These limits are designed to provide reasonable protection against harmful interference in a residential installation. This equipment generates, uses and can radiate radio frequency energy and, if not installed and used in accordance with the instructions, may cause harmful interference to radio communications. However, there is no guarantee that interference will not occur in a particular installation. If this equipment does cause harmful interference to radio or television reception, which can be determined by turning the equipment off and on, the user is encouraged to try to correct the interference by one of the following measures:

- Reorient or relocate the receiving antenna.
- Increase the separation between the equipment and receiver.
- Connect the equipment into an outlet on a circuit different from that to which the receiver is connected.
- Consult the dealer or an experienced radio/TV technician for help.

FCC Caution: Any changes or modifications not expressly approved by the party responsible for compliance could void the user's authority to operate this equipment.

This transmitter must not be co-located or operating in conjunction with any other antenna or transmitter.

Radiation Exposure Statement:

The product (FCC ID: PTP-TU1601) comply with the FCC portable RF exposure limit set forth for an uncontrolled environment and are safe for intended operation as described in this manual. The further RF exposure reduction

can be achieved if the product can be kept as far as possible from the user body or set the device to lower output power if such function is available.

Industry Canada statement:

This device (IC: 10617A-TU1601) complies with ISED's licence-exempt RSSs. Operation is subject to the following two conditions: (1) This device may not cause harmful interference, and (2) this device must accept any interference received, including interference that may cause undesired operation.

Le présent appareil est conforme aux CNR d'ISED applicables aux appareils radio exempts de licence. L'exploitation est autorisée aux deux conditions suivantes : (1) le dispositif ne doit pas produire de brouillage préjudiciable, et (2) ce dispositif doit accepter tout brouillage reçu, y compris un brouillage susceptible de provoquer un fonctionnement indésirable.

Radiation Exposure Statement:

The product (IC: 10617A-TU1601) comply with the Canada portable RF exposure limit set forth for an uncontrolled environment and are safe for intended operation as described in this manual. The further RF exposure reduction can be achieved if the product can be kept as far as possible from the user body or set the device to lower output power if such function is available.

Déclaration d'exposition aux radiations:

Le produit est conforme aux limites d'exposition pour les appareils portables RF pour les Etats-Unis et le Canada établies pour un environnement non contrôlé.

Le produit est sûr pour un fonctionnement tel que décrit dans ce manuel. La réduction aux expositions RF peut être augmentée si l'appareil peut être conservé aussi loin que possible du corps de l'utilisateur ou que le dispositif est réglé sur la puissance de sortie la plus faible si une telle fonction est disponible.

Federal Communication Commission Interference Statement

This device (FCC ID: PTP-TU1602) complies with Part 15 of the FCC Rules. Operation is subject to the following two conditions: (1) This device may not cause harmful interference, and (2) this device must accept any interference received, including interference that may cause undesired operation.

This equipment has been tested and found to comply with the limits for a Class B digital device, pursuant to Part 15 of the FCC Rules. These limits are designed to provide reasonable protection against harmful interference in a residential installation. This equipment generates, uses and can radiate radio frequency energy and, if not installed and used in accordance with the instructions, may cause harmful interference to radio communications. However, there is no guarantee that interference will not occur in a particular installation. If this equipment does cause harmful interference to radio or television reception, which can be determined by turning the equipment off and on, the user is encouraged to try to correct the interference by one of the following measures:

- Reorient or relocate the receiving antenna.
- Increase the separation between the equipment and receiver.
- Connect the equipment into an outlet on a circuit different from that to which the receiver is connected.
- Consult the dealer or an experienced radio/TV technician for help.

FCC Caution: Any changes or modifications not expressly approved by the party responsible for compliance could void the user's authority to operate this equipment.

This transmitter must not be co-located or operating in conjunction with any other antenna or transmitter.

Radiation Exposure Statement:

This equipment (FCC ID: PTP-TU1602) complies with FCC radiation exposure limits set forth for an uncontrolled environment. This equipment should be installed and operated with minimum distance 20cm between the radiator & your body.

Industry Canada statement:

This device (IC: 10617A-TU1602) complies with ISED's licence-exempt RSSs. Operation is subject to the following two conditions: (1) This device may not cause harmful interference, and (2) this device must accept any interference received, including interference that may cause undesired operation.

Le présent appareil est conforme aux CNR d' ISED applicables aux appareils radio exempts de licence. L'exploitation est autorisée aux deux conditions suivantes : (1) le dispositif ne doit pas produire de brouillage préjudiciable, et (2) ce dispositif doit accepter tout brouillage reçu, y compris un brouillage susceptible de provoquer un fonctionnement indésirable.

Radiation Exposure Statement:

This equipment (IC: 10617A-TU1602) complies with ISED radiation exposure limits set forth for an uncontrolled environment. This equipment should be installed and operated with minimum distance 20cm between the radiator & your body.

Déclaration d'exposition aux radiations:

Cet équipement est conforme aux limites d'exposition aux rayonnements ISED établies pour un environnement non contrôlé. Cet équipement doit être installé et utilisé avec un minimum de 20 cm de distance entre la source de rayonnement et votre corps.

European Union Regulatory Conformance

This equipment is CE marked according to the provisions of the R&TTE Directive (99/5/EC) and is in compliance with the essential requirements and other relevant provisions of the Directive 1999/5/EC. This equipment meets the following conformance standards:

EN 300 328, EN62479, EN 301 489-1&17, EN 60950-1

EU Declaration of Conformity

Hereby, Salutica Allied Solutions Sdn. Bhd. declares that this Bluetooth device is in compliance with the essential requirements and other relevant provision of Directive 1999/5/EC.

Caution: Changes or modifications to this **FOBO** device not expressly Approved by the party responsible for compliance could void the user's authority to operate it.

Bluetooth Wireless Compatibility:

This **FOBO** device supports the following Bluetooth wireless protocols and profiles:

- Bluetooth core technology v4.0
- Battery Profile (BAS)
- Proximity (PXP)
- Device Information Service (DIS)

Bluetooth Wireless Interoperability:

This **FOBO** device is designed to be interoperating with all Bluetooth wireless products that support compatible profiles and roles including:

- Bluetooth core technology v4.0
- Bluetooth master and slave roles

NCC Statement 低功率電波輻射性電機管理辦法

第十二條 經型式認證合格之低功率射頻電機，非經許可，公司、商號或使用者均不得擅自變更頻率、加大功率或變更原設計之特性及功能。

第十四條 低功率射頻電機之使用不得影響飛航安全及干擾合法通信；經發現有干擾現象時，應立即停用，並改善至無干擾時方得繼續使用。前項合法通信，指依電信法規定作業之無線電通信。低功率射頻電機須忍受合法通信或工業、科學及醫療用電波輻射性電機設備之干擾。

13 Intellectual Properties

- FOBO™ is a trademark of Salutica Allied Solutions Sdn Bhd. All rights reserved.
- FOBO™ Ultra incorporates a few patent pending technologies solely owned by Salutica Allied Solutions Sdn Bhd.
- Bluetooth® is a registered trademark owned by Bluetooth SIG Inc.
- iPhone® is a registered trademark of Apple Inc.

14 Limited Warranty & Disclaimer

14.1 Warranty

FOBO Ultra comes with a 12 months limited warranty. This Limited Warranty does not cover: 1) products purchased from an unauthorized reseller; 2) products purchased through online auctions; 3) products that are operated in combination with software, peripheral or ancillary equipment such as but not limited to batteries, chargers, adapters, headsets, connector cables, and power supplies ("Ancillary Equipment") not furnished or otherwise certified by Salutica for use with the FOBO products or any damage to the FOBO products or ancillary equipment as a result of such use; 4) damage caused by (a) accident, fire, misuse, neglect, unusual physical or electrical stress, or modification; (b) improper or unauthorized installation, wiring, repair, testing or (c) use of the product outside Salutica's published guidelines; 5) instances in which someone other than Salutica (or its authorized service centers) tests, alters, modifies or services the products in any way; 6) products that have (a) serial numbers or date tags that have been removed or altered, or (b) nonconforming or non-FOBO housings or parts; and 7) consumable spare parts and accessories (unless they are found to be non-functional or broken upon purchase of product).

In order to obtain any warranty service, you agree to bear all shipping charges of the FOBO Ultra device to Salutica's address.

14.2 Disclaimer

SALUTICA MAKES NO OTHER EXPRESS WARRANTY WHETHER WRITTEN OR ORAL AND SALUTICA EXPRESSLY DISCLAIMS ALL WARRANTIES AND CONDITIONS NOT STATED IN THIS LIMITED WARRANTY. TO THE EXTENT ALLOWED BY THE LOCAL LAW OF JURISDICTIONS OUTSIDE MALAYSIA, SALUTICA DISCLAIMS ALL IMPLIED WARRANTIES OR CONDITIONS, INCLUDING ANY IMPLIED WARRANTIES OF MERCHANTABILITY AND FITNESS FOR A PARTICULAR PURPOSE. FOR ALL TRANSACTIONS OCCURRING IN MALAYSIA, ANY IMPLIED WARRANTY OR CONDITION OF MERCHANTABILITY, SATISFACTORY QUALITY, OR FITNESS FOR A PARTICULAR PURPOSE IS LIMITED TO THE WARRANTY PERIOD AS PROVIDED BY SALUTICA IN THE MATERIALS RECEIVED AT THE TIME OF PURCHASE.

No warranty is made that the software provided by Salutica will meet your requirements or will work in combination with any hardware or Applications software products provided by third parties, that the operation of the software products will be uninterrupted or error free, or that all defects in the software products will be corrected.

14.3 Limitation of Liability

THE MAXIMUM LIABILITY OF SALUTICA UNDER THIS LIMITED WARRANTY IS EXPRESSLY LIMITED TO THE LESSER OF THE PRICE YOU HAVE PAID FOR THE PRODUCT OR THE COST OF REPAIR OR REPLACEMENT OF THAT PRODUCT OR ANY COMPONENT OR PART THAT MALFUNCTION IN CONDITIONS OF NORMAL USE. EXCEPT AS INDICATED ABOVE, IN NO EVENT WILL SALUTICA BE LIABLE FOR ANY DAMAGES CAUSED BY THE FOBO ULTRA PRODUCT OR THE FAILURE OF THE PRODUCT TO PERFORM, INCLUDING ANY LOST PROFITS OR SAVINGS OR SPECIAL, INCIDENTAL, OR CONSEQUENTIAL DAMAGES. SALUTICA IS NOT LIABLE FOR ANY CLAIM MADE BY A THIRD PARTY OR MADE BY YOU FOR A THIRD PARTY. THIS LIMITATION OF LIABILITY APPLIES WHETHER DAMAGES ARE SOUGHT, OR A CLAIM MADE, UNDER THIS LIMITED WARRANTY OR AS A TORT CLAIM (INCLUDING NEGLIGENCE AND STRICT PRODUCT LIABILITY), A CONTRACT CLAIM, OR ANY OTHER CLAIM. THIS LIMITATION OF LIABILITY CANNOT BE WAIVED OR AMENDED BY ANY PERSON. THIS LIMITATION OF LIABILITY WILL BE EFFECTIVE EVEN IF YOU HAVE ADVISED SALUTICA OR AN AUTHORIZED REPRESENTATIVE OF SALUTICA OF THE POSSIBILITY OF ANY SUCH DAMAGES. THIS LIMITATION OF

LIABILITY, HOWEVER, WILL NOT APPLY TO CLAIMS FOR PERSONAL INJURY.

14.4 What Law Governs This Warranty

THIS LIMITED WARRANTY IS GOVERNED BY AND CONSTRUED UNDER THE LAWS OF MALAYSIA.