



# FOBO Tire User Manual

Version 1.1

(for iOS7.1 and Android 4.30 & above)

# Contents

- 1 Introduction**
- 2 About FOBO Tire**
- 3 Importance of tire care**
- 4 Description of FOBO Tire**
  - 4.1 In-Car unit**
  - 4.2 Tire Sensor unit**
  - 4.3 Sensor lock nuts & wrench**
- 5 Start to use FOBO Tire**
  - 5.1 Installing FOBO Tire app**
  - 5.2 Installing FOBO Tire In-car unit and sensors**
  - 5.3 Setting up multiple users**
  - 5.4 Tire rotation**
  - 5.5 Disable sensor and Replace new sensor**
  - 5.6 Transfer FOBO Tire to another user**
- 6 FOBO Tire Alert Messages**
- 7 In-Car unit audio & LED alerts**
- 8 Replacing Battery**
- 9 Trouble Shooting Guide**
- 10 FOBO Tire Specifications**
- 11 Warning**
- 12 Regulatory Information**
- 13 Intellectual Properties**
- 14 Limited Warranty and Disclaimer**



# **1 Introduction**

FOBO Tire is the world's most advanced Tire Pressure Monitoring System (TPMS) using Bluetooth Smart (Bluetooth 4.0) technology to monitor your car tire pressure and temperature. Bluetooth Smart is a very low power wireless technology that could operate on a single coin cell battery for up to two years (**NOTE: Battery life may vary according to usage and climatic temperature. Operating under extreme cold may drastically reduce battery life.**)

Please ensure that your smart phone has Bluetooth Smart Ready (Bluetooth 4.0) capability in order to use FOBO Tire. Currently FOBO Tire works best with iOS7.1 and Android 4.30 and above.

Before starting to use FOBO Tire, please download the free FOBO Tire app to your smart phone from Google PlayStore or Apple AppStore.

FOBO Tire is a product designed and produced by Salutica Allied Solutions Sdn. Bhd. ("Salutica"), a Malaysian company with its address at No. 3, Jalan Zarib 6, Kawasan Perindustrian Zarib, 31500 Lahat, Ipoh, Perak, Malaysia.

# **2 About FOBO Tire**

FOBO Tire monitors your car tires non-stop around the clock. Most drivers have encountered situations where they need to rush for an urgent appointment only to be halted by a flat tire. Conventional Tire Pressure Monitoring Systems (TPMS) could not pre-alert you because they stop operating as soon as the car ignition is switched-off. With FOBO Tire, you will get an alert as soon as the tire pressure drops below a certain pre-set level, even when the car ignition is switched off. You will be alerted if you are within Bluetooth range (~30m). This pre-alert gives you time to get the flat tire fixed before you need to use the car for next appointment.

FOBO Tire can monitor up to 20 cars on each smart phone. This gives the user full information of the tires for all the cars without switching on. You will know which car tire is under-inflated without having to start the car engines one by one. **NOTE: Under certain conditions the signals from FOBO Tire sensors may be blocked by surrounding objects or structures. If this occurs, please move around the vehicle in order to capture signals from all the tire sensors.**



For those who are sharing car with family members or friends, you can allow others to use your FOBO Tire with permission. And it is simple, just key in the e-mail address that the other user will be using to login to FOBO Tire app.

FOBO Tire consists of four sensors and one in-car unit. Replace your tire valve caps with the sensors and place the in-car unit inside the car. The sensors will measure tire pressure of each tire and transmit via Bluetooth to the in-car unit. In case of any problem, the in-car unit will produce alert sound to notify user of any problem. In-car unit also comes with LEDs to show position of the problematic tire.

FOBO Tire system requires a smart phone and app for installation. Besides being able to view more information of your car tires, the smart phone app will also produce alert sound when your tire has a problem.

**DISCLAIMER: FOBO TIRE IS NOT AN ANTI-ACCIDENT DEVICE AND IT IS NOT A SUBSTITUTE FOR SAFE TIRE MAINTENANCE PRACTICES. PLEASE CONTINUE TO TAKE PRECAUTIONARY MEASURES WHILE DRIVING AND TAKE FULL RESPONSIBILITY OF YOUR VEHICLE'S TIRE CONDITION TO ENSURE SAFETY WHILE DRIVING. YOU SHOULD CONTINUE TO PRACTICE PROPER TIRE CARE AND SCHEDULED TIRE MAINTENANCE.**

### **3 Importance of tire care**

It is extremely important to ensure car tires are properly inflated for safety while driving. However, most drivers tend to neglect proper tire care and maintenance. Car tires are the only contact holding the car to the road. The air pressure inside the tires is supporting the weight of the car and passenger loads. Improperly inflated car tires may cause serious accidents on the road.

When the car tires are underinflated, the full weight of the car may compress and distort the tire side walls. Continued use of underinflated tires may lead to heat build-up and cause de-lamination of the tire materials thus increasing chances of tire blow-out. Underinflated tires will also wear faster around the tire shoulders causing uneven tire wear. Gas mileage will reduce due to more drag when driving with underinflated tires.

For some drivers, they tend to overinflate their car tires to get better mileage. However an overinflated car tire tends to bulge at the center radial causing uneven wear. Water dispersion may also be affected when tires are overinflated increasing chances of hydroplaning. That's when the car may spin out of control when driving on wet road.

What is the optimum tire pressure? There are a lot of information about this subject in internet forums and web articles. A quick guide for better understanding of tire pressure below:

- 1) Car manufacturers recommend the optimum tire pressure for their car models. The information is usually available on a sticker at the door jam (side of the driver's door) or in the owner's manual. For some car models, the information sticker may be on the trunk lid or on the fuel door. Car manufacturers usually recommend different tire pressure for front and rear tires. This pressure is usually recommended for comfort driving and optimum performance of the car. It is not advisable to go below this recommended pressure level.
- 2) The car manufacturer recommended tire pressure is "cold pressure". When you drive your car to the gas station, the friction on the road will heat up your car tires within a few minutes. Typically there will be 1psi (7kPa) increase in air pressure for every 10°C (50 °F) increase in tire temperature. It is advisable to inflate the tire pressure with this compensated pressure above the recommended pressure.
- 3) Air pressure is a direct function of temperature. Check and adjust your tire pressure whenever there is a drastic change in environment temperature, eg. change of season.
- 4) Tires will deflate over time by itself even without any puncture. Usually the air leak mostly comes from the tire valves. Change the tire valves or at least check the valves condition every time you change a new set of tires. Under normal condition, a set of tires could deflate at a rate of up to 2psi per month. It is good practice to check your tire pressure regularly and top up to the optimum pressure.
- 5) Every car tire has a recommended maximum load pressure. You should not use your car tire at this pressure. It is dangerous to inflate your car tire to the maximum load pressure.

## 4 Description of FOBO Tire

### 4.1 In-Car Unit



Tire position indicators – To indicate which tire has problem

Side button

- **In normal condition:** Short press side button to check status of In-Car unit whether it is sleeping or in operational mode.

**During tire alert:** When there is a tire alert, short press side button to silent the alert. After silencing the alert, a short press again will reproduce the tire alert once.

**Synchronizing with smartphone:** Long press the side button to sync user settings with the smartphone. Similar long press is also used during releasing of In-Car unit and pairing the unit.

**NOTE: Excessive frequent pressing on the side button will drain the In-Car unit battery.**

- Status indicator - LED will blink to show Bluetooth pairing mode or battery low status
- Alert buzzer - buzzer to alert when there is problem with tire
- AA batteries - In car unit operates with two AA size batteries. The batteries will work for up to two years.

FOBO Tire In-Car unit is a complicated device that performs many functions. Due to shielding effect of the car body metal, some drivers may face difficulty to get sensor signals to their smartphone when sitting inside the car. This problem may be further aggravated when driver places the smartphone close to the body, in trouser pocket or waist pouch. The In-Car unit is designed with an efficient antenna that can pick up sensor signals up to 10dB better than a usual smartphone. With the In-Car unit, user can be assured of good signal reception from the sensors.

The In-Car unit is designed to be placed anywhere inside the car, please do not remove from inside the car. FOBO Tire system requires the In-Car unit to remain inside the car in order to be fully functional as a system. Note that In-Car unit is not water-proof. Best location to place the In-Car unit will be to affix it on the lower dashboard position but away from direct sunlight. Use the Velcro double side tape provided in the packaging to secure the In-Car unit. Do not enclose the In-Car unit inside any metal compartment or box. This will make the In-Car unit unable to receive signals from tire sensors.

The In-Car unit will also synchronize all user settings changed on the smartphone every time it wakes up. For any changed settings in the app, it will only be synchronized in the next In-Car unit wake up cycle. Alternatively you can long press the side button of In-Car unit until you hear a beep, in order to put the In-Car unit into synchronization mode with the smartphone app. Note that the In-Car unit will go into sleep if the car is not moving for a long time. This is to conserve the battery life of In-Car unit. However the sensors will continue operational for 24x7 and alert user in case of flat tire when user is away from the car.

The In-Car unit is also meant to be a back-up alert device in case user did not bring smartphone into the car or the smartphone is set to silent mode. When there is a tire problem, the In-Car unit will produce audio and visual LED alerts to inform user of a tire problem. To silent the repetitive audio alerts, short press the side button once. In case user wants to reproduce the alert to check the location of problematic tire, short press the side button once more.

In-Car unit will produce a start-up tone “di da” every time it wakes up after detecting a car movement. This tone is also to inform the user or driver that In-Car unit is operational.



In case user does not hear this tone when start moving the car, please check the state of the In-Car unit by short pressing the side button once. If you hear “daaaa” tone that means the In-Car is in sleep mode unable to wake up. You can change the detection sensitivity in the Car Setting -> Advance Setting screen to trigger the In-Car wake-up. This may happen to some electric cars where In-Car unit may require higher sensitivity to detect car moving.

**NOTE: Unnecessarily waking up the In-Car unit will drain battery.**



## 4.2 Tire Sensor Unit



- |                         |  |
|-------------------------|--|
| Knob cover              | - waterproof cover. Please ensure the red silicon ring is intact to prevent water from getting into electronics compartment. |
| Single internal battery | - CR2032 coin cell battery. When replacing battery, please ensure “+” of the battery facing top, away from PCB.              |
| Internal PCB            | - internal electronics circuit   |

FOBO Tire sensor units are designed to be robust and working reliably 24x7 to provide tire information. It is designed to be water proof (IP57) and using special engineering plastics, will be able to withstand road salts or other common automotive chemicals (petrol, engine oil, car wash shampoo, etc).

Extreme care had been exercised when designing the mechanical sealing to prevent air leak. There is no need to screw in the sensor extremely tight. Apply a reasonable hand twist force to ensure the sensor is securely installed and should be able to be removed by hand with ease.

Note that the sensor position is fixed during installation. This is to ensure the app and In-Car unit able to identify problematic tire position. If the sensor position is mixed up, you can do a Rotating Tire procedure from the app to identify the sensor positions again.

A missing sensor or damaged sensor can be replaced easily using the replacing sensor procedure. In the app screen, click on the tire position that needs to be replaced for 5 seconds. An instruction message will guide you to install the new sensor. Individual replacement sensor is available for purchase from [www.my-fobo.com](http://www.my-fobo.com).

### 4.3 Sensor Lock nuts and wrench



FOBO Tire sensors and In-car unit are tied to a FOBO account after installation. They are not re-usable or transferable without the owner releasing them from his/her FOBO account. This is a theft deterrent feature to discourage theft.

As an additional anti-theft feature, all FOBO Tire package comes with lock-nuts and special wrench. Note that it is not necessary to use the lock nuts if user values convenience as higher priority than worrying about sensors being stolen. Not using the lock nuts will not affect functionality of FOBO Tire.

The lock nuts and wrench are made of special engineering plastics that can withstand road salts and common automotive chemicals (gasoline, engine oil, car wash shampoo, etc).

In order to use the lock nuts, first install the lock nut to the tire valve (with the bump facing tire rim). Screw in all the way down to make way for the sensor unit. Next, screw in the sensor unit until it is reasonably tight. Then use your finger to unscrew the lock nut upwards until it pushes against the bottom of the sensor unit. Use the wrench to tighten the lock nut. The resultant friction force will make it difficult to remove the sensor unit without loosening the lock nut. For rubber valves, hold the sensor unit with one hand and tighten the lock nut with the wrench on another hand. This to avoid the rubber valve from twisting making it unable to tighten the lock nut.

**WARNING: Do not apply too much force to tighten the lock-nut. You may face difficulty to loosen the lock nut later on.**

Use the key chain provided to keep the wrench together with your car keys, so that you don't have to worry about misplaced wrench when you need to remove the sensors when adding air to your tires.

## Steps to use FOBO Tire Lock Nut and wrench

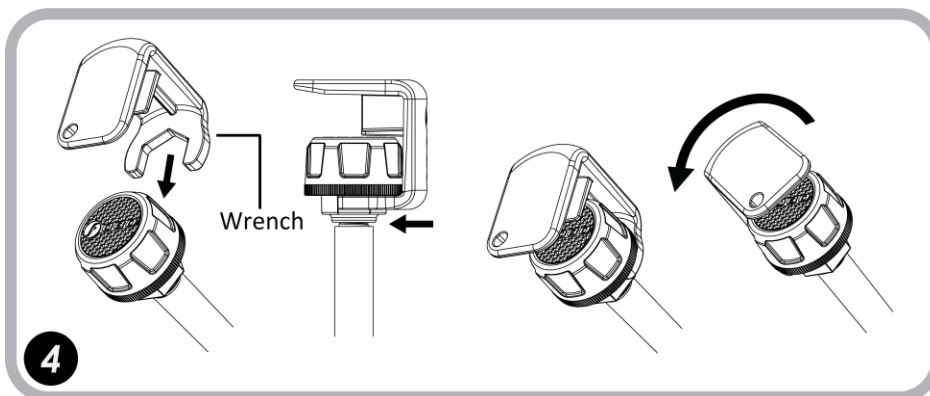
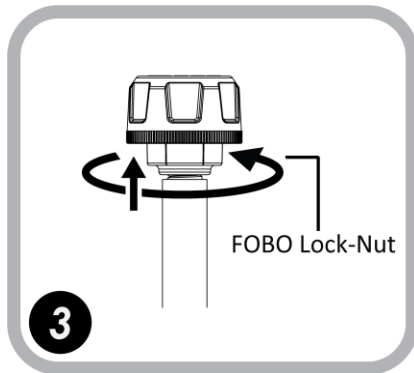
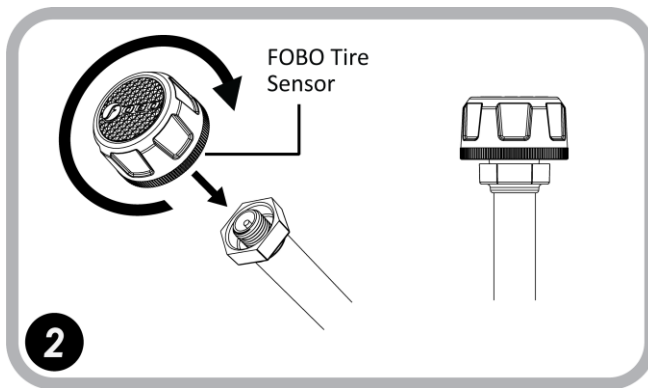
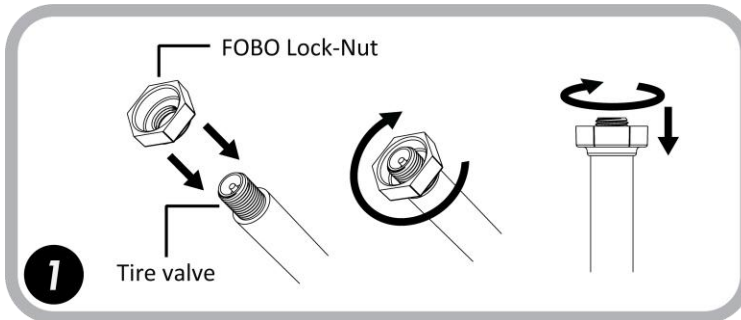

## **5 Start to use FOBO Tire**

### **5.1 Installing FOBO Tire app**

You are required to have smart phone with **Bluetooth 4.0** (Bluetooth Smart) capability in order to use FOBO Tire. Follow the steps below to install your FOBO Tire:

**Step 1:** Download FOBO Tire app to your smart phone

- For iPhone users, download from AppStore. For Android users, download from GooglePlay. Search for “FOBO Tire”.

**Step 2:** Launch FOBO Tire app & sign up a new user account

- Sign up a new account with a valid e-mail address

**NOTE: By submitting your information to sign up a new user account, you acknowledge your acceptance to the terms and conditions of our Software Licensing Agreement and Privacy Policy.**

**Please read the Software Licensing Agreement and Privacy Policy carefully before proceeding.**

- A verification e-mail message will be sent to your e-mail address.
- If you do not receive the verification e-mail from FOBO Admin, please check your e-mail address entry to ensure it is valid without typo error. It may end up in the wrong e-mail address.
- This e-mail may also be filtered by some e-mail servers. Please check the Spam mailbox.
- Please sign up again if you still did not receive any message from FOBO Admin. Upon successful verification, proceed to Login.

## 5.2 Installing FOBO Tire In-car unit & sensors

**NOTE: DO NOT INSTALL THE SENSORS TO THE CAR TIRE VALVES UNTIL INSTRUCTED BY THE FOBO TIRE APP INSTRUCTION**

**NOTE: INSTALLING FOBO TIRE SETS ON MORE THAN ONE CAR WHICH ARE PARKED CLOSELY TOGETHER MAY CAUSE CROSS INTERFERENCE TO THE BLUETOOTH SIGNALS. PLEASE INSTALL FOBO TIRE ON ONE CAR AT A TIME.**

Remove the battery tab from In-car unit battery compartment before proceeding for installation. In-car unit will be powered on immediately as soon as the battery tab is removed. Follow the below steps from the FOBO Tire app:

- 1) Click “+” on the app HOME screen to add a car to your profile.
- 2) Key in the name you would like to identify your car with and take the picture.
- 3) Select the car manufacturer recommended pressure for both front and rear tires. The information is usually available on a sticker at the door jam (side of the driver’s door) or in the owner’s manual. For some car models, the information sticker may be on the trunk lid or on the fuel door. The app will not work without this information.
- 4) Click “Done” on the top right hand corner of the screen.
- 5) Next, you will be prompted to install the tire sensors. Screw in the FOBO Tire sensor to your Front-Right tire. Make sure your smart phone is nearby or touching the sensor to detect signal from the sensor unit. Repeat with Rear-Right, Rear-Left and Front-Left tires. You will be prompted that installation is completed and you are now ready to use FOBO Tire.



## **5.3 Setting up multiple users**

FOBO Tire is easy to share with your family members and friends. You can share FOBO Tire with up to 100 users. All that is required is to key in the other user's e-mail address in the FOBO Tire app Setting screen. Please ensure good internet connection for FOBO Tire app to connect to the cloud.

The other user will just have to download FOBO Tire app and login using the above e-mail address. And they are now ready to use your FOBO Tire.

Note that shared users will not be able to change settings (name, user limits, etc) on your FOBO Tire set. They can only view the readings and get tire alerts.

## **5.4 Tire rotation**

It is good practice to rotate your tire positions regularly to balance the thread wear of your tires. Once tire position is changed, please select Tire Rotation in car status screen. You will be guided by the app to:

- 1) move to the front right tire of your car
- 2) place your phone close to the sensor and hold for 15 seconds. For faster response, you can also unscrew the sensor fully from the tire and screw it back.
- 3) repeat step 1 & 2 for rear right, rear left and front left tires.
- 4) Tire rotation is complete

You are now ready to use FOBO Tire with the new tire positions. You can perform tire rotation as often as you want.

## **5.5 Disable sensor and Replace new sensor**

You may want to disable a sensor due to sensor missing or sensor damaged. Disabling sensor will remove future missing sensor alerts. To disable sensor, long press for 5 seconds on the box corresponding to the tire position you want to disable. Click OK on the message box to disable the sensor. You will see “Disabled” inside the box corresponding to the disabled tire position. Take note that FOBO Tire will stop monitoring tire for a disabled sensor position.

In case the lost sensor is found or you have purchased a new replacement sensor, you may want to install onto the “Disabled” tire position. Note that you can only install replacement sensor after the tire position has been “Disabled”. To install replacement sensor, long press for 5 seconds on the box corresponding to the “Disabled” tire position. You will get a message prompting you to screw in the sensor to the indicated tire position. Click OK on the message box to begin installation procedure. Once the sensor is paired, you will get tire pressure reading on the screen.

## **5.6 Transfer FOBO Tire to another user**

Before passing on your FOBO Tire set to another user, you will have to release the In-Car unit from your login account. Select “Release In-Car unit” in car setting screen. Make sure your In-Car unit is with you. You will be prompted with a message to press and hold the button at the side of In-Car unit until you hear a “Beep” sound and the car profile from your “Home” page is erased. Your FOBO Tire set is now available for the other user to pair and use.



In case you do not hear a “Beep” after more than one minute, you may remove the batteries from back of In-Car unit and re-sit the batteries to reset the unit. Then select “Release In-Car unit” and repeat the procedure in above paragraph.



## **7 FOBO Tire Alert Messages**

You will get the below alert messages on your smart phone during operation of FOBO Tire under different conditions. The In Car unit will also generate different alert tones to inform the urgency. When you get continuous non-stop two-tone alert, please find a safe location to stop your car and check the alert messages on the smart phone.

### **7.1 Pressure too low**

You will get this alert when tire pressure drops below 15% from recommended pressure. **NOTE: IT IS DANGEROUS TO DRIVE WITH LOW TIRE PRESSURE. THE FULL WEIGHT OF THE CAR AND PASSENGER LOAD WILL BE COMPRESSING THE TIRE WALLS AND MAY CAUSE TIRE FAILURE LEADING TO ACCIDENTS, INJURY OR DEATH.**

### **7.2 Pressure too high**

This alert will happen when tire pressure increases above 35% from your car tire recommended pressure or when pressure touches the 350kPa (3.5bar/51psi). It is not advisable to drive at high tire pressure for too long. It will cause excessive uneven wear to the tire thread.

### **7.3 Temperature too high**

FOBO Tire will alert when the temperature detected exceeds 60°C/140°F. Note that the temperature inside the tire may be higher than the temperature detected by FOBO Tire sensors due to the air cooling effect on the tire valve when the car is moving. It is extremely dangerous to drive when you get this alert message.

**WARNING: WHEN YOU SEE THIS ALERT, PLEASE STOP YOUR CAR IMMEDIATELY AND CHECK THE TIRE!**

### **7.4 Signal low or sensor missing**

This alert happens when the In-car unit fails to communicate with the sensor. It could be the sensor signal is blocked, sensor unit damaged or missing from the tire. If confirmed the sensor is damaged or missing, you could disable the sensor in order to continue using FOBO Tire with remaining working sensors. Please purchase the sensor replacement immediately. It is not advisable to continue driving without FOBO Tire actively monitoring one or more of your car tires.

## **7.5 Pressure below preset limit**

This alert happens when the tire pressure drops below pre-set lower limit. The recommended range for low limit is 8% below recommended pressure. You may change this lower limit in the setting screen down to 15% below recommended pressure. For fuel economy and optimum tire performance, it is recommended to keep this range tight so that you get frequent reminder to re-inflate your car tires. If you find the reminder is too frequent, you may want to check your tire for any leakage. Note that drastic temperature drop may also cause tire pressure drop. Please check your tire pressure and re-inflate during change of season.

## **7.6 Pressure above preset limit**

This alert happens when the tire pressure increases above pre-set upper limit. The recommended range for upper limit is 25% above recommended pressure. You could change this upper limit up to 35% above recommended pressure. For optimum tire performance and grip, you should not overinflate your car tires. Note that the tire pressure will increase as the car tires heat up due to friction while driving.

## **7.7 Sensor battery level low**

When the sensor battery level drops to certain level, you will get this alert. Please change the battery immediately after you get this alert. You will continue to get this alert every time you start moving your car until the battery is changed.

## **7.8 In-car unit battery level low**

This alert happens when the In-car unit battery reaches certain low level. Please change the battery immediately after you get this alert. You will continue to get this alert every time you start moving your car until the battery is changed.

## **8 In-Car unit audio & LED alerts**

In-Car unit will produce different tones and LED flashes for different situations. For repetitive alerts, you can stop the alerts by pressing the In-Car unit side button once. In case you have forgotten the location of the problematic tire, you can short press the side button another time to re-produce the alert one time.

**Wake up** – unit will produce “di da” tone once with LED blinking sequentially for all four tire indicators. This shows that In-Car unit is awake and operational.

**Sleep** – unit will produce “daaa” tone once. No LED blink. This shows In-Car unit is going to sleep and not operational. In-Car unit goes to sleep to conserve battery when car is not moving for a long time. However the sensors will still be operational 24x7 and continue to monitor and alert to your handphone in case of flat tire.

**Soft alert** – unit will produce “di di di di di” tone once and repeat every 3 minutes. LED will blink for 5 seconds on problematic tire. This alert is for non-emergency situation such as:-

- Tire pressure slightly exceed above or below user pre-set limits. It is not dangerous to continue driving.
- Sensor battery low. Once notified on low sensor battery, please remember to change the battery at your convenience. Do not leave the unit to continue operating under low battery for a long time.
- In-car unit battery low. LED blink will be on the status LED, not on the tire indicator LED. Once notified on low sensor battery, please remember to change the battery at your convenience. Do not leave the unit to continue operating under low battery for a long time.
- Signal low or sensor missing. For this situation, the tone will repeat every 5 seconds instead of 3 minutes to inform user of a possible missing sensor.

**Emergency alert** – unit will produce “di da di da di da” tone once and repeat every 5 seconds. LED will continue to blink on problematic tire. This alert is for emergency situation such as:-

- Tire pressure is too high or too low. It is not recommended to continue driving without investigating the condition of the tire. Please stop the car at a safe location to check the condition of the tire.
- Tire temperature is too hot, exceeding 60°C or 140°F. It is not recommended to continue driving without investigating the condition of the tire. Please stop the car at a safe location to check the condition of the tire. Note that the measured temperature may be lower by 10°C or 50°F compared to the in-tire air temperature when the car is moving, due to air cooling effect on the tire valve.



**NOTE: FOBO TIRE IS A MONITORING DEVICE TO ALERT THE USER WHEN IT DETECTED SIGNALS THAT IS OUT OF PRE-SET CONDITIONS. THE USER OR DRIVER IS SOLELY RESPONSIBLE TO FIND OUT THE ACTUAL CONDITION OF THE TIRE. FOBO IS NOT RESPONSIBLE FOR WRONG DIAGNOSTICS OR FALSE ALERTS THAT MAY CAUSE INCONVENIENCE.**

## **9 Replacing Battery**

The coin cell battery (CR2032) used in FOBO Tire sensors could last up to two years on normal operation. Similarly the AA battery used in FOBO Tire In-car unit could last up to two years on normal operation. Operating in extreme cold temperatures may reduce battery operating life for both sensors and In-car unit.

You will get an alert on the smart phone and in-car unit when the sensor or In-car unit battery goes below indicated level. You will be alerted every time you start to drive your car until the battery is replaced. It is advisable to change the battery once you get this battery alert to ensure proper performance of FOBO Tire. Do not wait until the battery is fully drained as it will cause FOBO Tire to stop working especially when you need it.

To replace the battery of sensor unit, unscrew the top cover. Be careful not to damage the rubber gasket as it may affect water resistance of the sensor unit. Ensure the battery (CR2032) is inserted “+” side up facing away from the PCB.

To replace battery for the In-car unit, slide out the battery cover. Ensure the battery (AA) is inserted in the correct orientation. It is advisable to use good quality AA batteries (recommended Lithium or Alkaline) for longer lasting performance of In-car unit.

**WARNING: RE-USING OLD BATTERIES OR MIXING OLD AND NEW BATTERIES IN IN-CAR UNIT MAY DAMAGE THE ELECTRONICS.**

## 10 Trouble Shooting Guide

- Could not sign up a new FOBO account (did not receive authentication e-mail)
  - Check the e-mail address entry is typed correctly
  - Check the Spam mailbox, in case the e-mail was filtered by the e-mail server
  - Check the smart phone is connected to internet and able to receive e-mail
  
- Could not sign up a new FOBO account (received authentication e-mail)
  - Make sure to click on the “Activation” link of the latest e-mail, in case there are multiple authentication e-mails
  - You should be directed to web page that clearly displayed “FOBO account is activated”.
  
- Unable to Login after signing up to FOBO app
  - Make sure your e-mail address is typed correctly
  - A verification mail will be sent to your e-mail address
  - Follow the instruction in the mail to activate your account before you can Login
  - Check if internet connection is available on your smart phone
  
- Unable to pair FOBO Tire In-car unit
  - Make sure the battery is installed correctly and battery tab is removed.
  - Press the side button on In-Car unit and hold for 2 seconds
  - Make sure your smart phone has Bluetooth 4.0 (Smart Ready) capability. **NOTE: BLUETOOTH 2.0 OR 3.0 WILL NOT WORK WITH THIS DEVICE.**
  - Please check if the FOBO Tire has been paired before to another Login account. You’ll need to “Release” the FOBO Tire set from the Login account that it is paired to, before using on your account. The FOBO Tire is designed to pair with one Login account only for theft deterrent feature.
  - Try to reset the Bluetooth manager of your smart phone (for iOS: Settings-> Bluetooth-> OFF->ON). At times the Bluetooth manager may be disrupted which may require manual reset.
  
- Unable to pair FOBO Tire sensors
  - Make sure the sensor is screwed onto a tire valve with pressure above 100kPa
  - Try unscrew the sensor from tire valve, screw it back and try again
  - Make sure the battery is installed correctly with battery “+” on top.

- Make sure your smart phone has Bluetooth 4.0 (Smart Ready) capability. **NOTE: BLUETOOTH 2.0 OR 3.0 WILL NOT WORK WITH THIS DEVICE.**
- Try to reset the Bluetooth manager of your smart phone (for iOS: Settings-> Bluetooth-> OFF->ON). At times the Bluetooth manager may be disrupted which may require manual reset.

## **11 FOBO Tire Specifications**

- **Bluetooth:** v4.0
- **Supported profiles:** GAP, GATT attributes, Device Information Service, Proximity Reporter, Battery Service
- **Transmit Conducted Power:** +4.0dBm
- **Receiver Sensitivity:** -90dBm
- **Antenna Return Loss:** -10dB
- **Operating Frequency:** 2.4 GHz
- **Weight:** 10 grams (sensor) & 38g (In-car unit)
- **Sensor Dimension H x D:** 16mm x 26mm
- **In-car unit Dimension HxWxL:** 20mm x 45mm x 85mm
- **Maximum Pressure:** 350kPa (50psi)
- **Battery Type:** CR2032 (sensor) & AA (In-car unit). Operating life up to two years. (**NOTE: The battery operating life varies according to usage and climate temperature**)
- **Operating Temperature:** -40°C to 85°C
- **ESD:** 8kV air, 4kV direct contact
- **Operating Humidity:** up to 90% non condensing at 40°C
- **Dust and Water Proof:** IEC60529 compliant to IP57

## **12 Warning**

- **Take note that FOBO Tire is not meant to function as anti-accident or anti-injury device. FOBO Tire is not a substitute for safe tire maintenance practices. Please take full responsibility of your own safety while driving. And continue to send your car for regular tire check and maintenance.**
- **Please take extra precaution to acoustics safety when operating the FOBO Tire In-car unit. Note that placing the FOBO Tire In-car unit beeper close to your ear may result in injury to the ear or permanent loss of hearing.**
- **You shall not use the FOBO Tire in any unlawful way that violates any laws.**
- **Avoid exposing the FOBO Tire In-car unit and sensors to solvent, fire or extreme temperatures.**
- **FOBO Tire may fail to function properly if the battery is below optimum level. Replace the battery immediately to continue enjoying full features of FOBO Tire.**

### **CAUTION**

**THERE MAY BE A RISK OF EXPLOSION IF BATTERY IS REPLACED BY AN INCORRECT TYPE. DISPOSE ALL USED BATTERIES PROPERLY.**

## **13 Regulatory Information**

### **Federal Communication Commission Interference Statement**

This device complies with Part 15 of the FCC Rules. Operation is subject to the following two conditions: (1) This device may not cause harmful interference, and (2) this device must accept any interference received, including interference that may cause undesired operation.

This equipment has been tested and found to comply with the limits for a Class B digital device, pursuant to Part 15 of the FCC Rules. These limits are designed to provide reasonable protection against harmful interference in a residential installation. This equipment generates, uses and can radiate radio frequency energy and, if not installed and used in accordance with the instructions, may cause harmful interference to radio communications. However, there is no guarantee that interference will not occur in a particular installation. If this equipment does cause harmful interference to radio or television reception, which can be determined by turning the equipment off and on, the user is encouraged to try to correct the interference by one of the following measures:

- Reorient or relocate the receiving antenna.
- Increase the separation between the equipment and receiver.
- Connect the equipment into an outlet on a circuit different from that to which the receiver is connected.
- Consult the dealer or an experienced radio/TV technician for help.

FCC Caution: Any changes or modifications not expressly approved by the party responsible for compliance could void the user's authority to operate this equipment.

This transmitter must not be co-located or operating in conjunction with any other antenna or transmitter.

#### **Radiation Exposure Statement:**

This equipment complies with FCC radiation exposure limits set forth for an uncontrolled environment. This equipment should be installed and operated with minimum distance 20cm between the radiator & your body.



### **Industry Canada statement:**

This device complies with RSS-210 of the Industry Canada Rules. Operation is subject to the following two conditions: (1) This device may not cause harmful interference, and (2) this device must accept any interference received, including interference that may cause undesired operation.

Ce dispositif est conforme à la norme CNR-210 d'Industrie Canada applicable aux appareils radio exempts de licence. Son fonctionnement est sujet aux deux conditions suivantes: (1) le dispositif ne doit pas produire de brouillage préjudiciable, et (2) ce dispositif doit accepter tout brouillage reçu, y compris un brouillage susceptible de provoquer un fonctionnement indésirable.

### **Radiation Exposure Statement:**

This equipment complies with IC radiation exposure limits set forth for an uncontrolled environment. This equipment should be installed and operated with minimum distance 20cm between the radiator & your body.

### **Déclaration d'exposition aux radiations:**

Cet équipement est conforme aux limites d'exposition aux rayonnements IC établies pour un environnement non contrôlé. Cet équipement doit être installé et utilisé avec un minimum de 20 cm de distance entre la source de rayonnement et votre corps.

### **European Union Regulatory Conformance**

This equipment is CE marked according to the provisions of the R&TTE Directive (99/5/EC) and is in compliance with the essential requirements and other relevant provisions of the Directive 1999/5/EC. This equipment meets the following conformance standards:

EN 300 328, EN62479, EN 301 489-1&17, EN 60950-1

### **EU Declaration of Conformity**

Hereby, Salutica Allied Solutions Sdn. Bhd. declares that this Bluetooth device is in compliance with the essential requirements and other relevant provision of Directive 1999/5/EC.

**Caution:** Changes or modifications to this **FOBO** device not expressly approved by the party responsible for compliance could void the user's authority to operate it.

**Bluetooth Wireless Compatibility:**

This **FOBO** device supports the following Bluetooth wireless protocols and profiles:

- Bluetooth core technology v4.0
- Battery Profile (BAS)
- Proximity (PXP)
- Device Information Service (DIS)

**Bluetooth Wireless Interoperability:**

This **FOBO** device is designed to be interoperating with all Bluetooth wireless products that support compatible profiles and roles including:

- Bluetooth core technology v4.0
- Bluetooth master and slave roles

## **14 Intellectual Properties**

- FOBO™ is a trademark of Salutica Allied Solutions Sdn Bhd. All rights reserved.
- FOBO™ Tire incorporates a few patent pending technologies solely owned by Salutica Allied Solutions Sdn Bhd.
- Bluetooth® is a registered trademark owned by Bluetooth SIG Inc.
- iPhone® is a registered trademark of Apple Inc.

## **15 Limited Warranty & Disclaimer**

### **Warranty**

FOBO Tire comes with a 12 months limited warranty. This Limited Warranty does not cover: 1) products purchased from an unauthorized reseller; 2) products purchased through online auctions; 3) products that are operated in combination with software, peripheral or ancillary equipment such as but not limited to batteries, chargers, adapters, headsets, connector cables, and power supplies ("Ancillary Equipment") not furnished or otherwise certified by Salutica for use with the FOBO products or any damage to the FOBO products or ancillary equipment as a result of such use; 4) damage caused by (a) accident, fire, misuse, neglect, unusual physical or electrical stress, or modification; (b) improper or unauthorized installation, wiring, repair, testing or (c) use of the product outside Salutica's published guidelines; 5) instances in which someone other than Salutica (or its authorized service centers) tests, alters, modifies or services the products in any way; 6) products that have (a) serial numbers or date tags that have been removed or altered, or (b) nonconforming or non-FOBO housings or parts; and 7) consumable spare parts and accessories (unless they are found to be non-functional or broken upon purchase of product).

In order to obtain any warranty service, you agree to bear all shipping charges of the FOBO Tire device to Salutica's address.

### **Disclaimer**

SALUTICA MAKES NO OTHER EXPRESS WARRANTY WHETHER WRITTEN OR ORAL AND SALUTICA EXPRESSLY DISCLAIMS ALL WARRANTIES AND CONDITIONS NOT STATED IN THIS LIMITED WARRANTY. TO THE EXTENT ALLOWED BY THE LOCAL LAW OF JURISDICTIONS OUTSIDE MALAYSIA, SALUTICA DISCLAIMS ALL IMPLIED WARRANTIES OR CONDITIONS, INCLUDING ANY IMPLIED WARRANTIES OF MERCHANTABILITY AND FITNESS FOR A PARTICULAR PURPOSE. FOR ALL TRANSACTIONS OCCURRING IN MALAYSIA, ANY IMPLIED WARRANTY OR CONDITION OF MERCHANTABILITY, SATISFACTORY QUALITY, OR FITNESS FOR A PARTICULAR PURPOSE IS LIMITED TO THE WARRANTY PERIOD AS PROVIDED BY SALUTICA IN THE MATERIALS RECEIVED AT THE TIME OF PURCHASE.

No warranty is made that the software provided by Salutica will meet your requirements or will work in combination with any hardware or applications software products provided by third parties, that the operation of the software products will be uninterrupted or error free, or that all defects in the software products will be corrected.

## **Limitation of Liability**

THE MAXIMUM LIABILITY OF SALUTICA UNDER THIS LIMITED WARRANTY IS EXPRESSLY LIMITED TO THE LESSER OF THE PRICE YOU HAVE PAID FOR THE PRODUCT OR THE COST OF REPAIR OR REPLACEMENT OF THAT PRODUCT OR ANY COMPONENT OR PART THAT MALFUNCTION IN CONDITIONS OF NORMAL USE. EXCEPT AS INDICATED ABOVE, IN NO EVENT WILL SALUTICA BE LIABLE FOR ANY DAMAGES CAUSED BY THE FOBO TIRE PRODUCT OR THE FAILURE OF THE PRODUCT TO PERFORM, INCLUDING ANY LOST PROFITS OR SAVINGS OR SPECIAL, INCIDENTAL, OR CONSEQUENTIAL DAMAGES. SALUTICA IS NOT LIABLE FOR ANY CLAIM MADE BY A THIRD PARTY OR MADE BY YOU FOR A THIRD PARTY. THIS LIMITATION OF LIABILITY APPLIES WHETHER DAMAGES ARE SOUGHT, OR A CLAIM MADE, UNDER THIS LIMITED WARRANTY OR AS A TORT CLAIM (INCLUDING NEGLIGENCE AND STRICT PRODUCT LIABILITY), A CONTRACT CLAIM, OR ANY OTHER CLAIM. THIS LIMITATION OF LIABILITY CANNOT BE WAIVED OR AMENDED BY ANY PERSON. THIS LIMITATION OF LIABILITY WILL BE EFFECTIVE EVEN IF YOU HAVE ADVISED SALUTICA OR AN AUTHORIZED REPRESENTATIVE OF SALUTICA OF THE POSSIBILITY OF ANY SUCH DAMAGES. THIS LIMITATION OF LIABILITY, HOWEVER, WILL NOT APPLY TO CLAIMS FOR PERSONAL INJURY.

## **What Law Governs This Warranty**

THIS LIMITED WARRANTY IS GOVERNED BY AND CONSTRUED UNDER THE LAWS OF MALAYSIA.