

CEMF11G01G0101

User Manual

GCT GDM7240R1 LTE Solution

REV 0.1

Samsung Electro-Mechanics

2011-11-11

Summary

This description presents the general specifications of CEMF11G01G0101 which designed for 3GPP LTE Band 13.

© 2011 Samsung Electro-Mechanics. All rights reserved

The names of actual companies and products mentioned herein may be the trademarks of their respective owners.

No part of this document may be reproduced, stored in a retrieval system, or transmitted in any form or by any means without the express written consent of Samsung Electro-Mechanics.

This document is subject to change without notice.

1 Electrical Characteristics

1.1 Power Supply

The CEMF11G01G0101 must be connected to a 3.3V power supply by PCI Express® Mini Card Electromechanical Specification Revision 1.2 Compliant.

Requirement type	Value
Power Supply	3.3V
Voltage range	3.1 ~ 3.6V
Maximum Current (Max Power +23dBm)	850mA

Table 1-1. Power Supply Requirements

1.2 General Characteristics

Item	LTE	Remark
Current consumption	Typ. 180mA	Connect with PC, With Test JIG
Radio Frequency	Tx : 777 ~ 787MHz Rx : 746 ~ 756MHz	Band 13
Bandwidth	10MHz	
Frequency Type	Earcfn	DL : 5230 / UL : 23230
Maximum Throughput	DL : 100Mbps UL : 50Mbps	Category 3
Modulation Format	DL : QPSK, 16QAM, 64QAM UL : QPSK, 16QAM	
Antenna Configuration	2 Rx Diversity	1 Tx - Main 2 Rx – Main, Diversity

Table 1-2. General Characteristics

1.3 Storage Condition

It needs proper condition for protecting the rust.

- Temperature : 0 ~ +50°C
- Humidity : lower level recommended, 25% ~ 65%RH
- Max Storage Limit : Within 6 month form production

2 RF Specification

2.1 LTE Specification

All measurements are made under nominal power supply and room temperature 25°C unless specified.

Test Item		Min	Typ	Max	Unit	Remark	
Tx	Maximum Output Power	+21.3	+23	+25.7	dBm	No MPR	
		+19.3				With MPR	
	Occupied Bandwidth	0		10	MHz		
	Spectrum Emission Mask				-16.5	dB	Δf_{OOB} : 15 ~ 85KHz
					-11.5		Δf_{OOB} : 150 ~ 950KHz
					-11.5		Δf_{OOB} : 1.5 ~ 9.5MHz
					-23.5		Δf_{OOB} : 10.5 ~ 14.5MHz
ACLR_EUTRA			-30	dB			
ACLR_UTRA			-33	dB	Freq Offset : 5MHz		
			-36		Freq Offset : 15MHz		
Transmit Signal Quality	EVM	0		17.5	%	QPSK	
				12.5		16QAM	
	Frequency Error	-0.1		0.1	ppm		
	IQ Offset	-999		-25	dBc		
Rx	Sensitivity	0		5	%	@ -95dBm	
	RSSI	-34	-30	-26	dBm	Main, Div	
		-54	-50	-46			
-84		-80	-76				

Table 2-1. LTE RF Specification

2.2 Antenna Connection

- **2 RF Port : U.FL Connector**

Main ANT Connector : 1EA

AUX ANT Connector : 1EA

- Main ANT Connector is sharing the Tx and Rx.

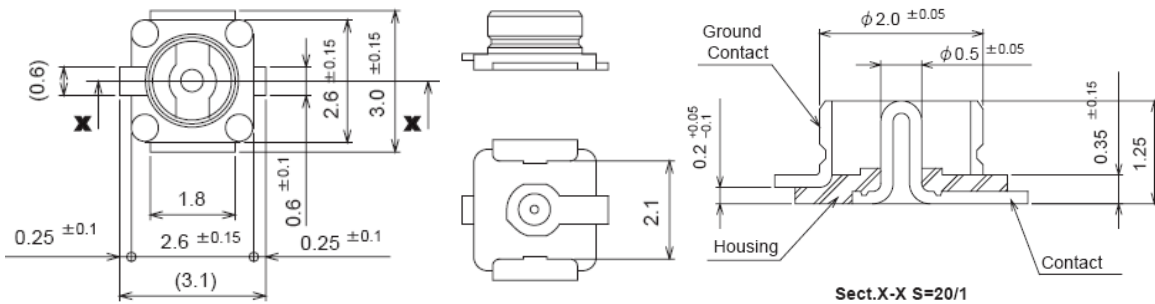
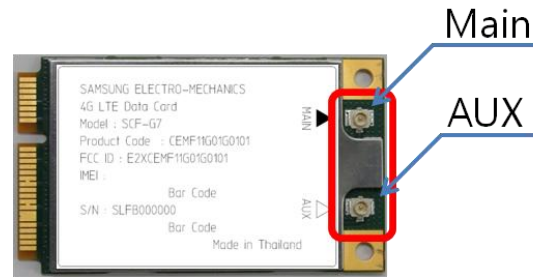

Figure 2-1. Antenna Connector Mechanical Dimension

Attaching an antenna to the CEMF11G01G0101 :

- Use a Hirose U.FL connector (Part No. : U.FL-R-SMT, CL No. : 331-0471-0-10) to attach an antenna to a connection point on the CEMF11G01G0101.
- Match coaxial connections between the CEMF11G01G0101 and the antenna to 50 Ω.
- Minimize RF cable losses between the CEMF11G01G0101 and the antenna to less than 0.5 dB.

2.3 Ground Connection

Connecting the CEMF11G01G0101 to system ground :

- Connect to system ground for preventing noise leakage.
- Connect with host connector, two mounting holes, and PCI express® mini card connector.

3 Label Information

3.1 Module Label

The Label contains Model Name, Product Code, FCC ID, IMEI and Serial Number.

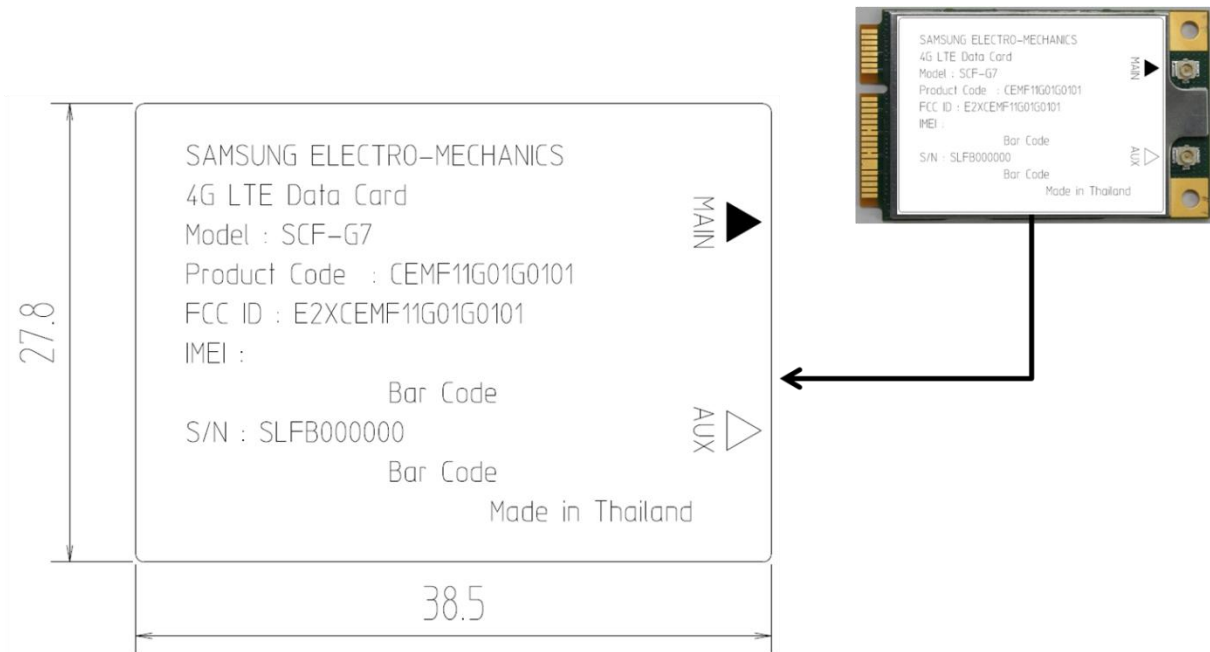

Figure 3-1. Module Label Information

3.1.1 S/N(Serial Number)

Ex)

S N F B 000001 ① ② ③ ④ ⑤

S	N	F	B	000001
①	②	③	④	⑤
Company S: Samsung	Custom Model N : CEMF11G01G0101	Year F:2011 G:2012	Month 1~9:Jan~SEP A:OCT, B:Nov, C:Dec	Serial No 000001 ~ FFFFFF (HEX)

Table 3-1. Serial Number Information

6 Safety Information

6.1 Certification

FCC ID : E2XCEMF11G01G0101

	<p>Warning: Exposure to Radio Frequency Radiation The radiated output power of this device is far below the FCC radio frequency exposure limits. Nevertheless, the device should be used in such a manner that the potential for human contact during normal operation is minimized. In order to avoid the possibility of exceeding the FCC radio frequency exposure limits, human proximity to the antenna should not be less than 20 cm during normal operation. The gain of the antenna for LTE band must not exceed 0 dBi.</p>
---	--

FCC Compliance Information

This device complies with Part 15 of FCC Rules.

Operation is subject to the following two conditions:

- (1) This device may not cause harmful interference, and
- (2) This device must accept any interference received.
Including interference that may cause undesired operation.

6.2 Caution

Modifications not expressly approved by the party responsible for compliance could void the user's authority to operate the equipment.

This equipment has been tested and found to comply with the limits for a Class A digital device, pursuant to part 15 of the FCC Rules. These limits are designed to provide reasonable protection against harmful interference in a residential installation. This equipment generates, uses and can radiate radio frequency energy and, if not installed and used in accordance with the instructions, may cause harmful interference to radio communications. However, there is no guarantee that interference will not occur in a particular installation. If this equipment does cause harmful interference to radio or television reception, which can be determined by turning the equipment off and on, the user is encouraged to try to correct the interference by one or more of the following measures:

- Reorient or relocate the receiving antenna.
- Increase the separation between the equipment and receiver.
- Connect the equipment into an outlet on a circuit different from that to which the receiver is connected.
- Consult the dealer or an experienced radio/TV technician for help.

Caution: Any changes or modifications to this device not explicitly approved by manufacturer could void your authority to operate this equipment.

For label requirement when transmitter module is installed in a host,
X
The host shall have an additional permanent label referring to the enclosed module

“Contains Transmitter Module FCC ID: } j - { } ‡ ~i i €hi €hi hi ”