

Installing accessories

Upgrading a memory module

Your machine has a dual in-line memory module (DIMM). Use this memory module slot to install additional memory. We recommend the use of only genuine Samsung DIMM's. You may void your warranty if it is determined that your machine problem is being caused by third party DIMM's.

The order information is provided for optional accessories (see "Available accessories" on page 89).



After installing the optional memory, you can use the advanced printing features, such as proofing a job and specifying of printing a secure print job in the printer properties window. You can control the active job queue and file policy in **Job Management** menu (see "Using optional device features" on page 311).

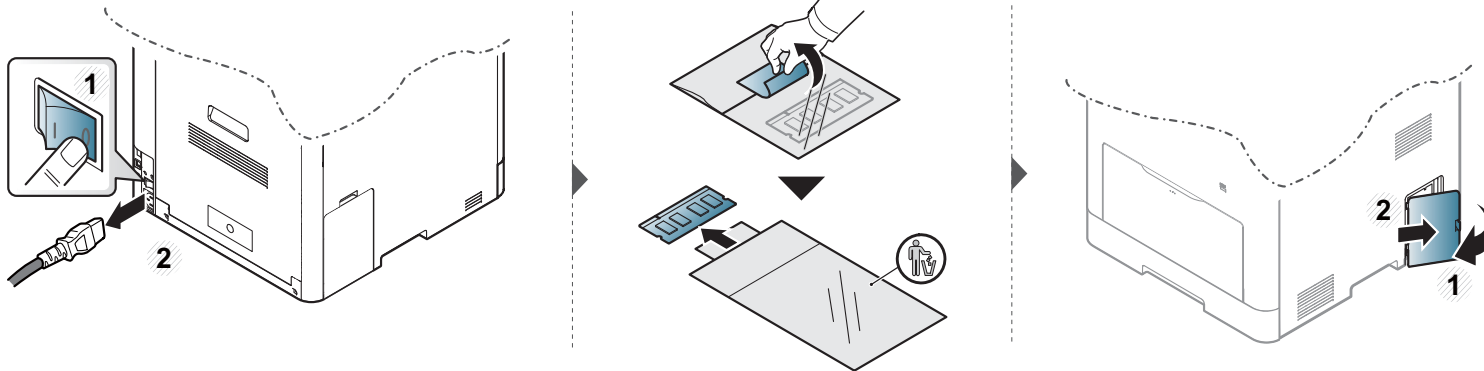

Installing accessories

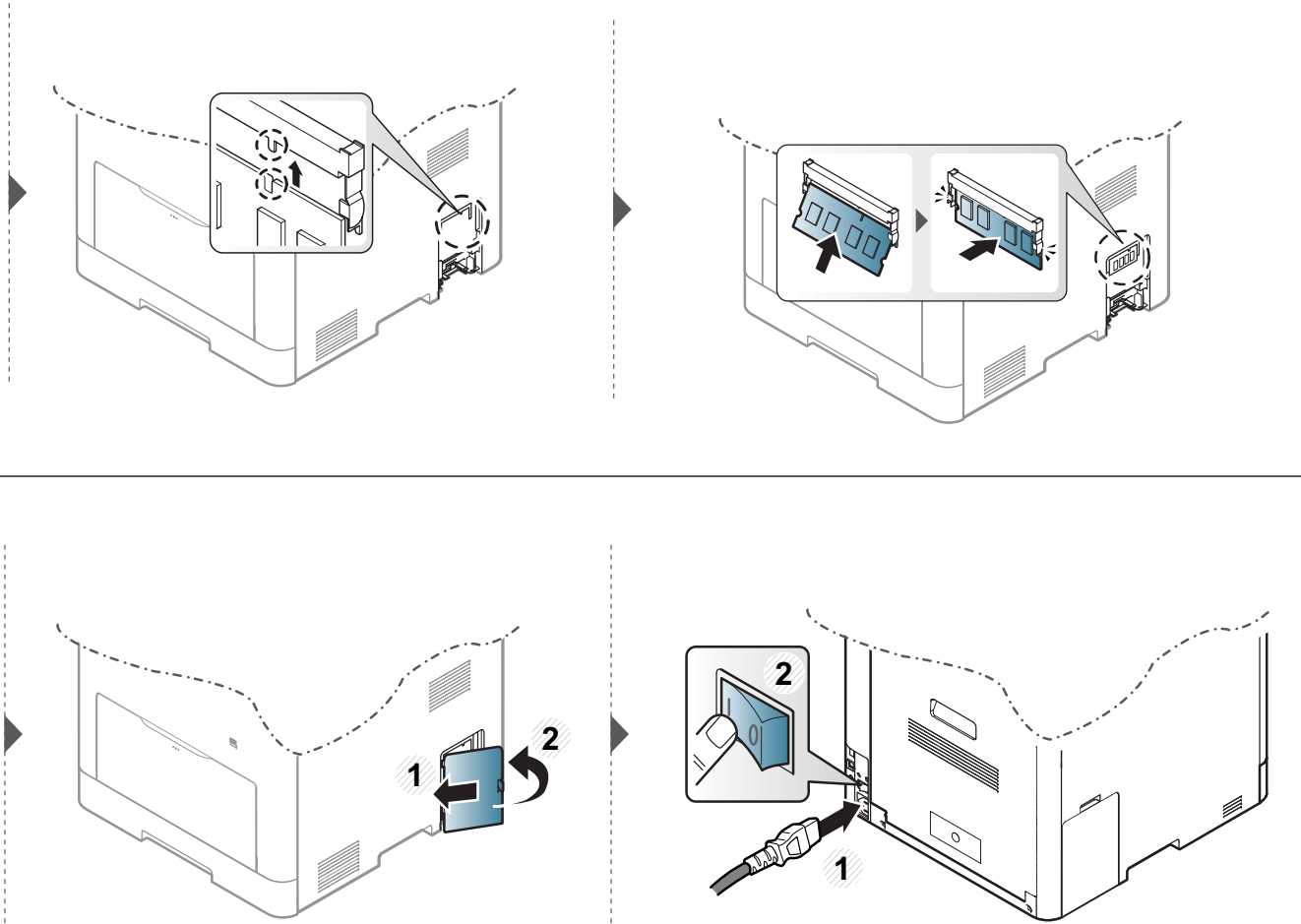



Monitoring the supplies life

If you experience frequent paper jams or printing problems, check the number of pages the machine has printed or scanned. Replace the corresponding parts, if necessary.



- Accessing menus may differ from model to model (see "Accessing the menu" on page 36).
- It may be necessary to press **OK** to navigate to lower-level menus for some models.

- 1 Select  (**Menu**) > **System Setup** > **Maintenance** > **Supplies Life** on the control panel.
- 2 Select the option you want and press **OK**.
 - **Supplies Info.:** Prints the supply information page.
 - **Total:** Displays the total number of pages printed.
 - **ADF Scan:** Displays the number of pages printed by using the document feeder.
 - **Platen Scan:** Displays the number of pages scanned by using scanner glass.
 - **Transfer Belt:** Displays the number of pages by using transfer belt.
 - **Fuser:** Displays the number of pages by using fuser.
 - **Tray1 Roller:** Displays the number of pages by using tray1 roller.
 - **Tray2 Roller^a:** Displays the number of pages by using tray2 roller.
 - **MP Tray Roller^a:** Displays the number of pages by using mp tray roller.
- 3 Press  (**Stop/Clear**) to return to ready mode.

a. CLX-626xND/CLX-626xFD/CLX-626xFR/CLX-626xFW Series only.

Setting the toner low alert

If the amount of toner in the cartridge is low, a message or LED informing the user to change the toner cartridge appears. You can set the option for whether or not this message or LED appears.



- Accessing menus may differ from model to model (see "Accessing the menu" on page 36).
- It may be necessary to press **OK** to navigate to lower-level menus for some models.
- You can set the machine's settings by using the **Device Settings** in Samsung Easy Printer Manager program.
 - For Windows and Macintosh users, you set from **Samsung Easy Printer Manager** >  **(Switch to advanced mode)** > **Device Settings**, see "Device Settings" on page 329.

- 1** Select  **(Menu)** > **System Setup** > **Maintenance** > **TonerLow Alert** on the control panel.
Or select **Setup** > **Machine Setup** > **Next** > **Initial Setup** > **Toner Status Alert** on the touch screen.
- 2** Select the option you want.
- 3** Press **OK** to save the selection.

Cleaning the machine

If printing quality problems occur or if you use your machine in a dusty environment, you need to clean your machine regularly to keep it in the best printing condition and use your machine longer.



- Cleaning the cabinet of the machine with cleaning materials containing large amounts of alcohol, solvents, or other strong substances can discolor or distort the cabinet.
- If your machine or the surrounding area is contaminated with toner, we recommend you use a cloth or tissue dampened with water to clean it. If you use a vacuum cleaner, toner blows in the air and might be harmful to you.

Cleaning the outside

Clean the machine cabinet with a soft, lint-free cloth. Dampen the cloth slightly with water, but be careful not to let any water drip onto or into the machine.

Cleaning the machine

Cleaning the inside

During the printing process, paper, toner, and dust particles can accumulate inside the machine. This buildup can cause print quality problems, such as toner specks or smearing. Cleaning the inside of the machine clears and reduces these problems.



- To prevent damage to the toner cartridge, do not expose it to light for more than a few minutes. Cover it with a piece of paper, if necessary.
- Do not touch the green area of the toner cartridge. Use the handle on the cartridge to avoid touching this area.
- Use a dry lint free cloth when cleaning the inside of the machine, be careful not to damage the transfer roller or any other inside parts. Do not use solvents such as benzene or thinner. Printing quality problems can occur and cause damage to the machine.



- Use a dry lint-free cloth to clean the machine.
- Turn the machine off and unplug the power cord. Wait for the machine to cool down. If your machine has a power switch, turn the power switch off before cleaning the machine.
- Illustrations on this user's guide may differ from your machine depending on its options or models. Check your machine type (see "Front view" on page 22).

Cleaning the machine

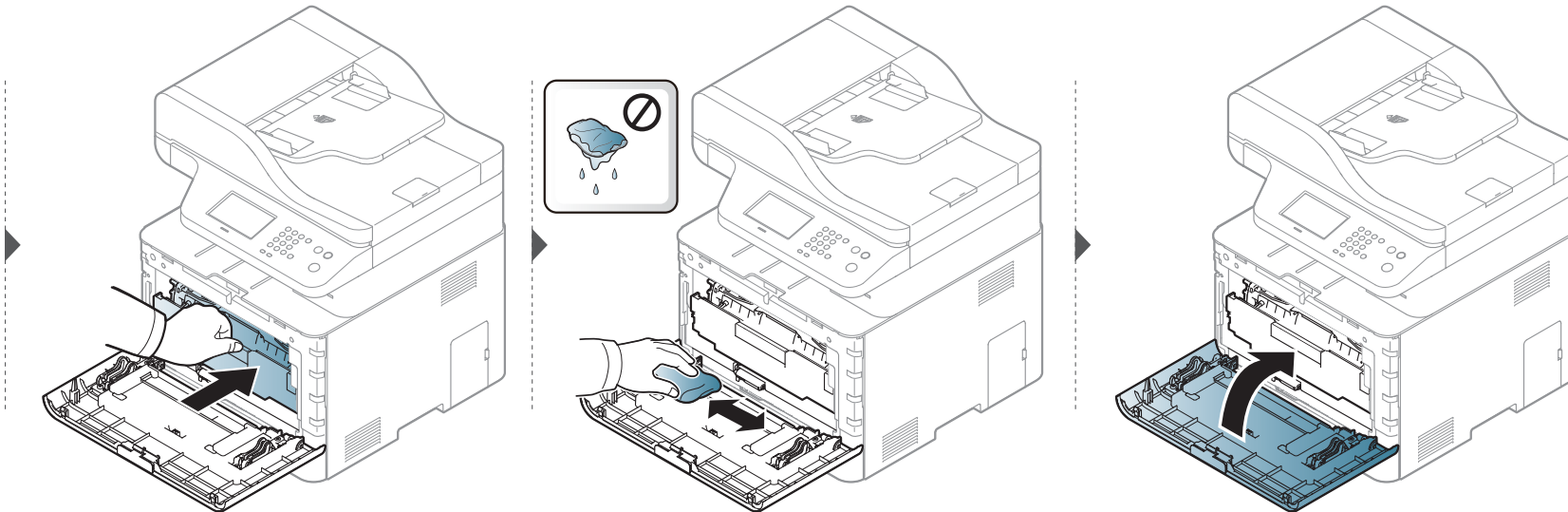
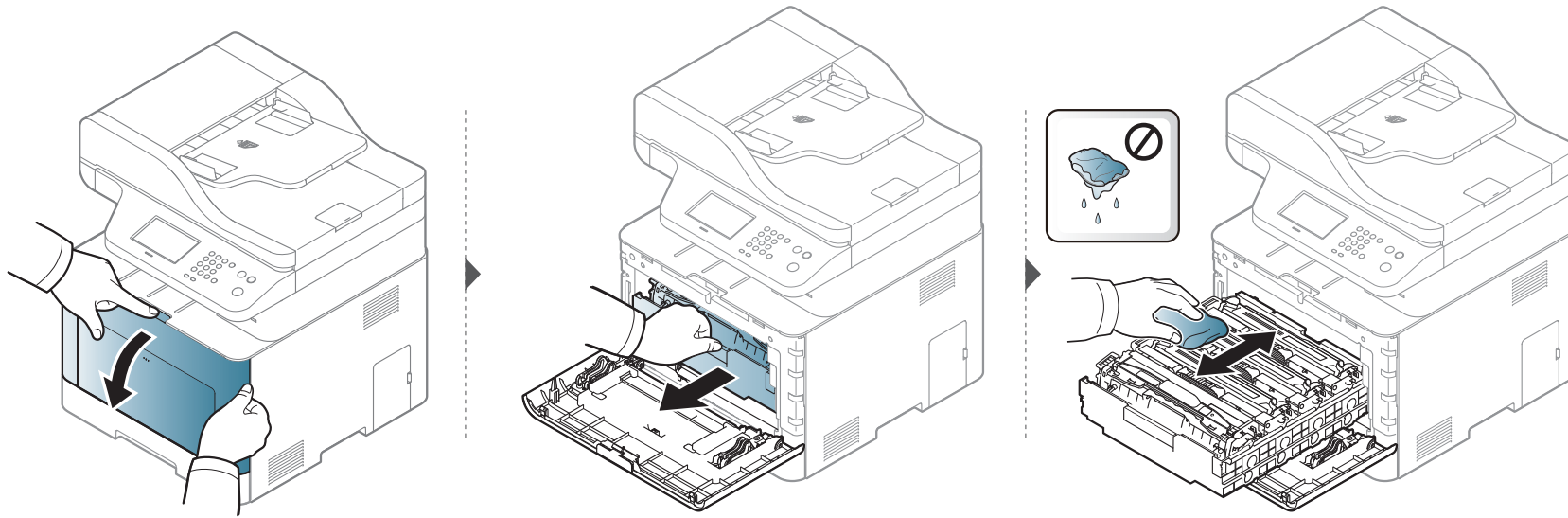

Cleaning the machine

Cleaning the pickup roller



- Turn the machine off and unplug the power cord. Wait for the machine to cool down. If your machine has a power switch, turn the power switch off before cleaning the machine.
- Illustrations on this user's guide may differ from your machine depending on its options or models. Check your machine type (see "Front view" on page 22).

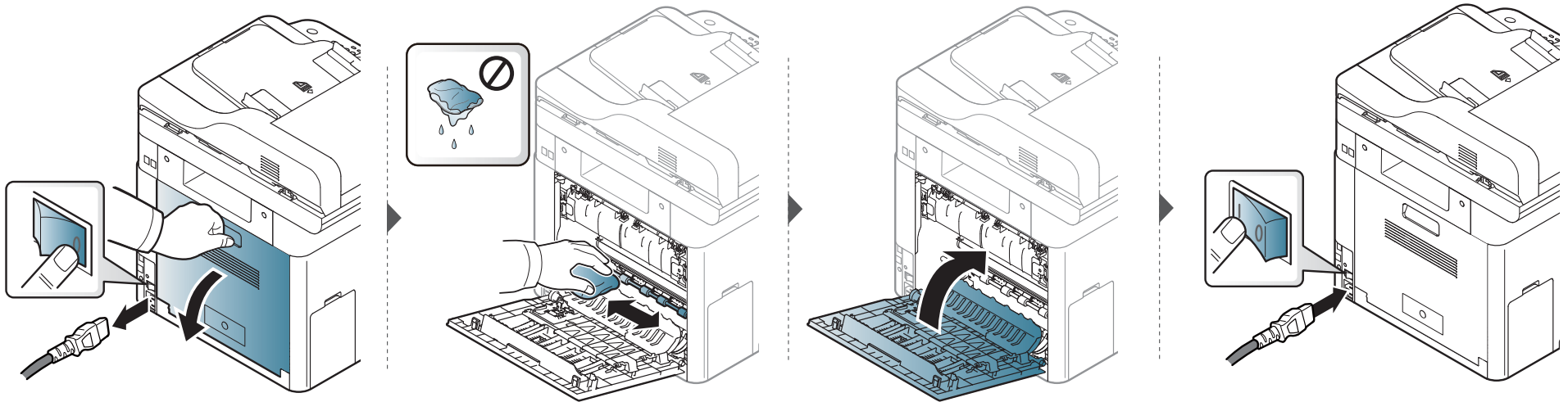

Cleaning the machine

Cleaning the scan unit

Keeping the scan unit clean helps ensure the best possible copies. We suggest that you clean the scan unit at the start of each day and during the day as needed.



- Turn the machine off and unplug the power cord. Wait for the machine to cool down. If your machine has a power switch, turn the power switch off before cleaning the machine.
- Illustrations on this user's guide may differ from your machine depending on its options or models. Check your machine type (see "Front view" on page 22).

1 Slightly dampen a soft, lint-free cloth or paper towel with water.

2 Lift and open the scanner lid.

3 Wipe the surface of the scanner until it is clean and dry.

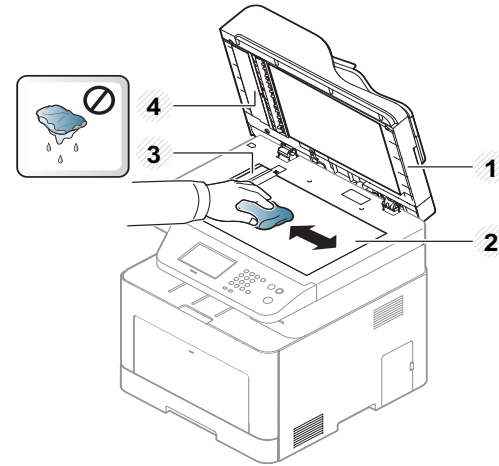

- 1 Scanner lid
- 2 Scanner glass
- 3 Document feeder glass
- 4 White bar

4 Close the scanner lid.

Tips for moving & storing your machine

Tips for moving & storing your machine

- When moving the machine, do not tilt or turn it upside down. Otherwise, the inside of the machine may be contaminated by toner, which can cause damage to the machine or reduce print quality.
- When moving the machine, make sure at least two people are holding the machine securely.



4. Troubleshooting

This chapter gives helpful information for what to do if you encounter an error.

- **Tips for avoiding paper jams** 113
- **Clearing original document jams** 114
- **Clearing paper jams** 119
- **Understanding the status LED** 131
- **Understanding display messages** 133



This chapter gives helpful information for what to do if you encounter an error. If your machine has a display screen, check the message on the display screen first to solve the error.

If you cannot find a solution to your problem in this chapter, refer to the **Troubleshooting** chapter in the Advanced Guide (see "Troubleshooting" on page 336).

If you cannot find a solution in the User's Guide or the problem persists, call for service.

Tips for avoiding paper jams

By selecting the correct media s, most paper jams can be avoided. To avoid paper jams, refer to the following guidelines:

- Ensure that the adjustable guides are positioned correctly (see "Tray overview" on page 48).
- Do not remove paper from the tray while your machine is printing.
- Flex, fan, and straighten paper before loading.
- Do not use creased, damp, or highly curled paper.
- Do not mix papers in a tray.
- Use only recommended print media (see "Print media specifications" on page 143).

Clearing original document jams

When an original document jams in the document feeder, a warning message appears on the display.

 To avoid tearing the document, remove the jammed document slowly and carefully.

 To prevent document jams, use the scanner glass for thick, thin or mixed paper- originals.

Clearing original document jams

Original paper jam in front of scanner



- Illustrations on this user's guide may differ from your machine depending on its options or models. Check your machine type (see "Front view" on page 22).
- This troubleshooting may not be available depending on model or optional goods (see "Variety feature" on page 10).

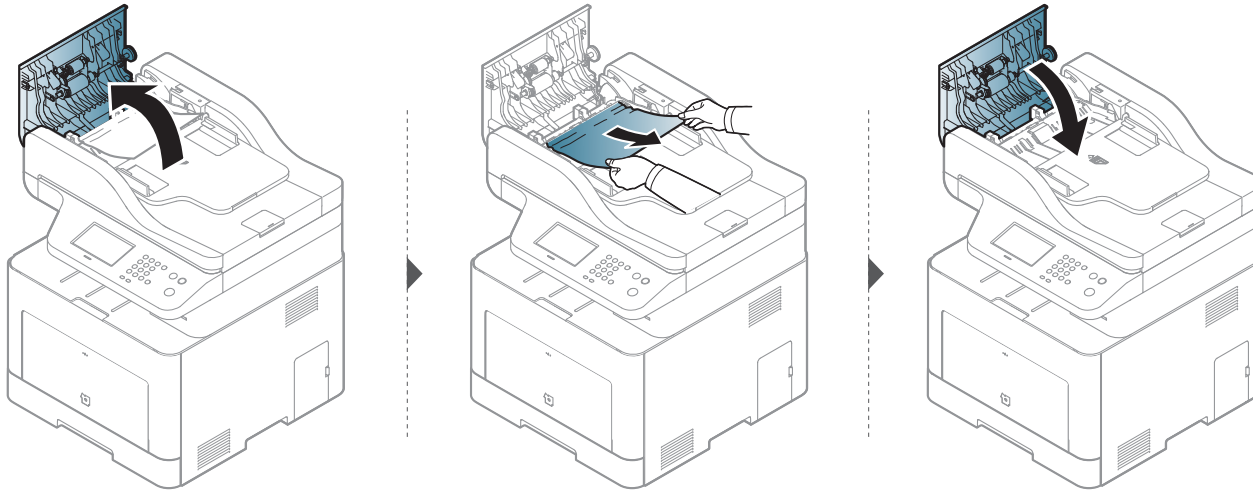

Clearing original document jams

Original paper jam inside of scanner



- Illustrations on this user's guide may differ from your machine depending on its options or models. Check your machine type (see "Front view" on page 22).
- This troubleshooting may not be available depending on model or optional goods (see "Variety feature" on page 10).

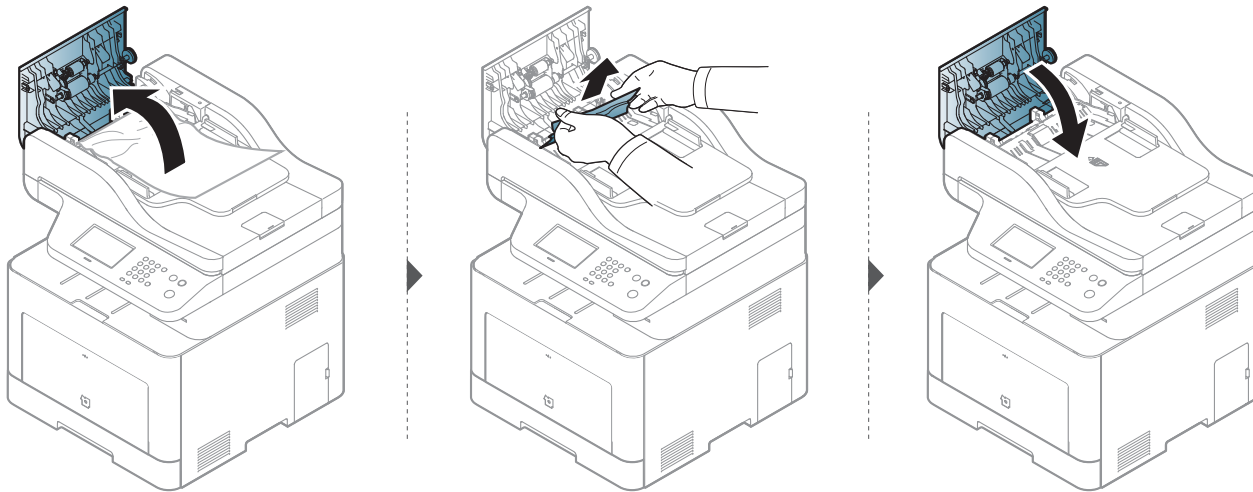

Clearing original document jams

Original paper jam in exit area of scanner



- Illustrations on this user's guide may differ from your machine depending on its options or models. Check your machine type (see "Front view" on page 22).
- This troubleshooting may not be available depending on model or optional goods (see "Front view" on page 22).

- 1 Remove any remaining pages from the document feeder.
- 2 Gently remove the jammed paper from the document feeder.

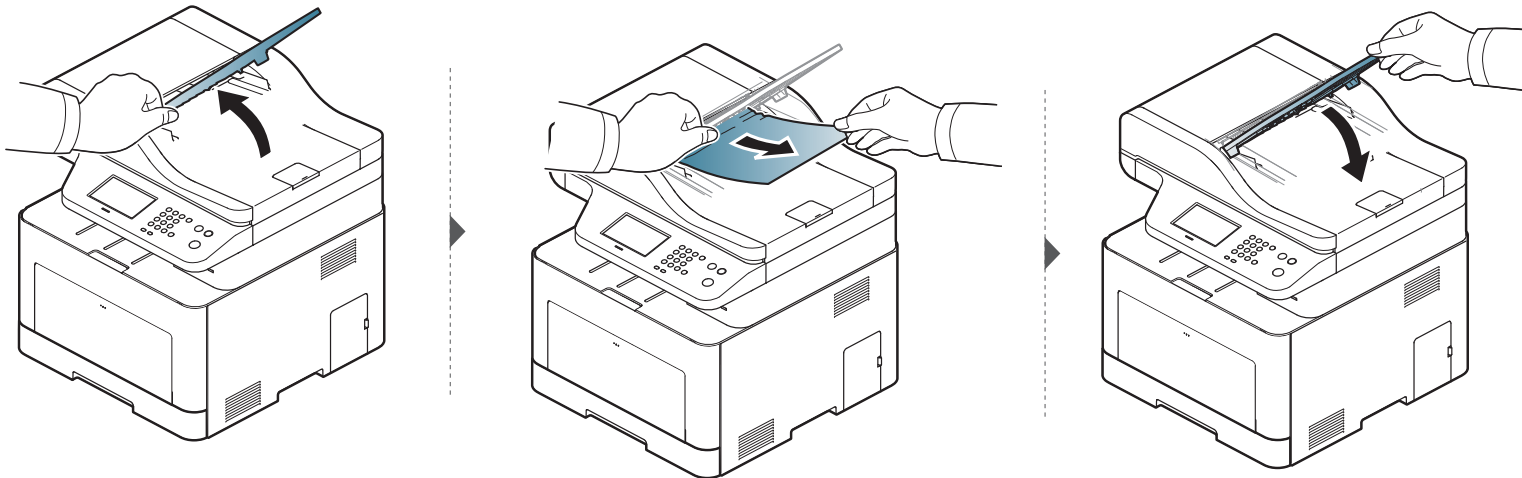

Clearing original document jams

Original paper jam in scanner duplex path



- CLX-626xFR/CLX-626xFW Series only.
- Illustrations on this user's guide may differ from your machine depending on its options or models. Check your machine type (see "Front view" on page 22).
- This troubleshooting may not be available depending on model or optional goods (see "Front view" on page 22).

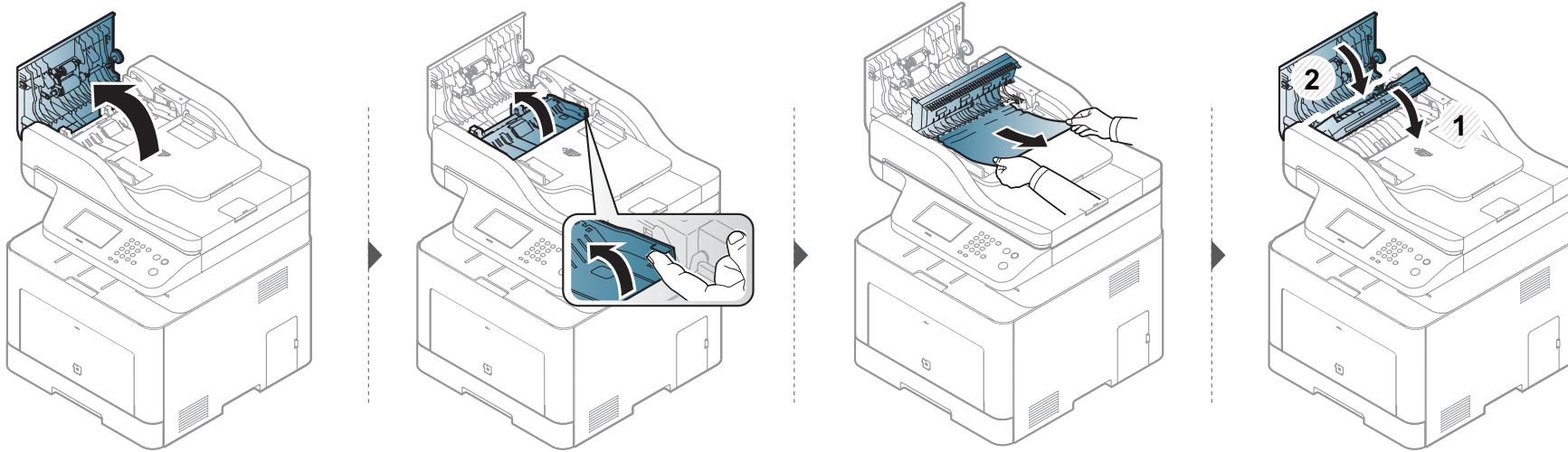

Clearing paper jams



To avoid tearing the paper, pull the jammed paper out slowly and gently.

In tray1



Click this link to open an animation about clearing a jam.



Illustrations on this user's guide may differ from your machine depending on its options or models. Check your machine type (see "Front view" on page 22).

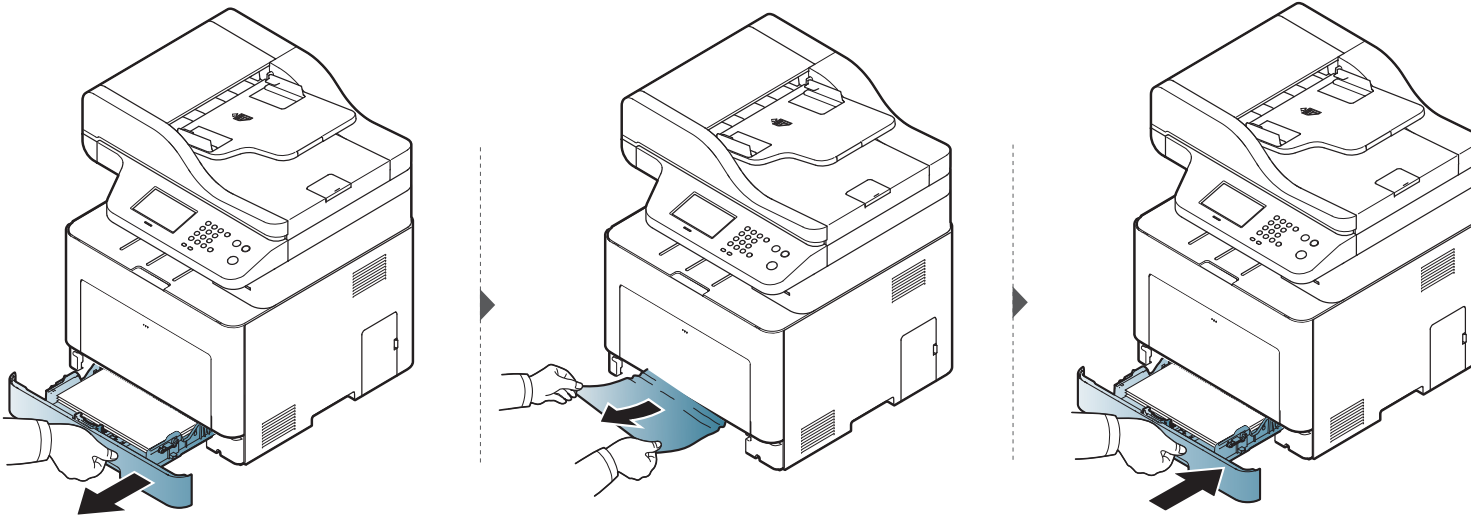

Clearing paper jams

In optional tray



Click this link to open an animation about clearing a jam.



- CLX-626xND/CLX-626xFD/CLX-626xFR/CLX-626xFW Series only.
- Illustrations on this user's guide may differ from your machine depending on its options or models (see "Available accessories" on page 89).

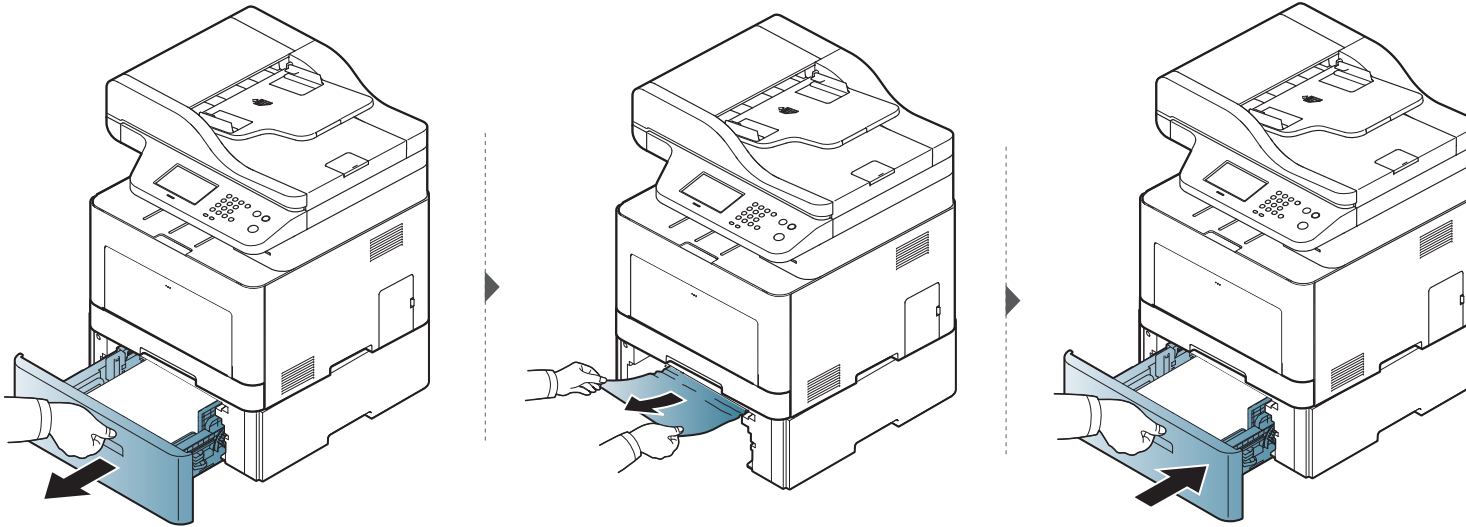

Clearing paper jams

If you do not see the paper in this area, stop and go to next step:

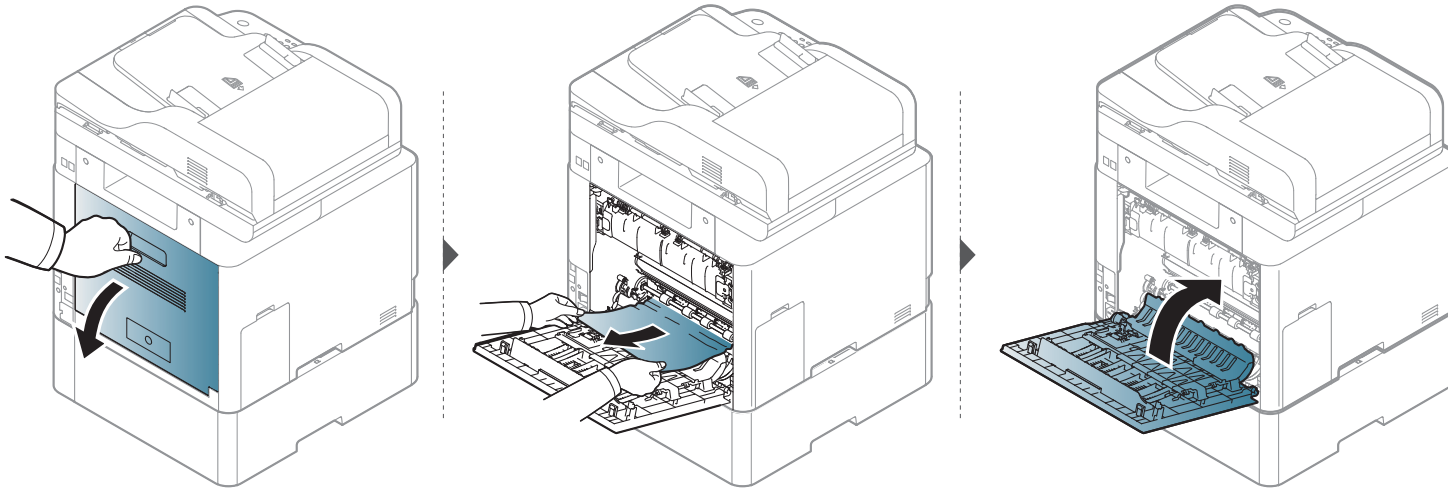

Clearing paper jams

In the manual feeder/multi-purpose tray

CLX-419xN/CLX-419xFN/CLX-419xFW Series



Click this link to open an animation about clearing a jam.

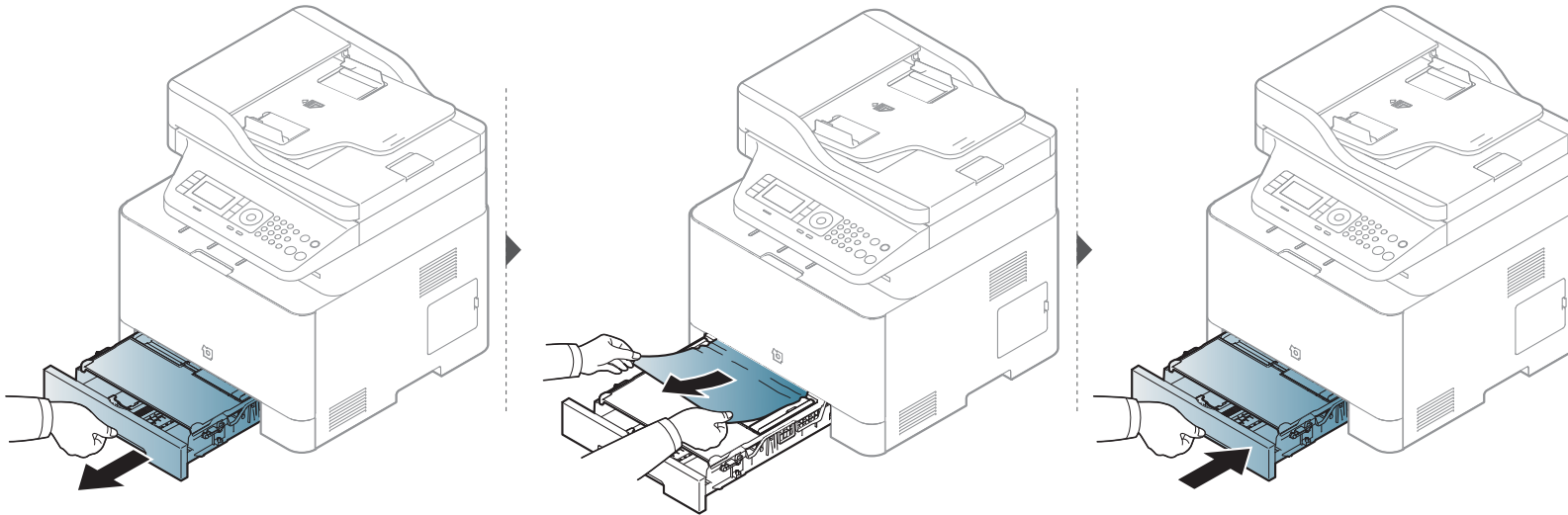

CLX-626xND/CLX-626xFD/CLX-626xFR/CLX-626xFW Series



Click this link to open an animation about clearing a jam.

Clearing paper jams



When you print using the multi-purpose tray and the machine detects that there is either no paper or that the paper has been improperly loaded, follow the next steps to release the jammed paper.

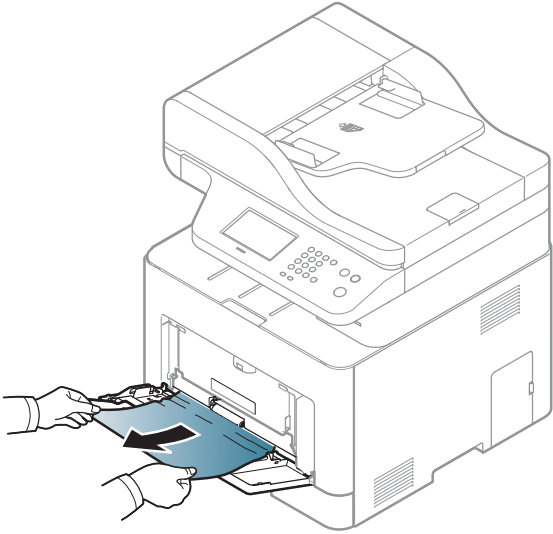

Clearing paper jams

If you do not see the paper in this area, stop and go to next step:

