

SAMSUNG









USER MANUAL

HW-N300

SAFETY INFORMATION

SAFETY WARNINGS

TO REDUCE THE RISK OF ELECTRIC SHOCK, DO NOT REMOVE THE COVER (OR BACK). NO USER-SERVICEABLE PARTS ARE INSIDE. REFER SERVICING TO QUALIFIED SERVICE PERSONNEL.

	CAUTION RISK OF ELECTRIC SHOCK. DO NOT OPEN.	
	This symbol indicates that high voltage is present inside. It is dangerous to make any kind of contact with any internal part of this product.	
	This symbol indicates that this product comes with important literature concerning operation and maintenance.	
	Class II product : This symbol indicates that a safety connection to electrical earth (ground) is not required.	
	AC voltage : Rated voltage marked with this symbol is AC voltage.	
	DC voltage : Rated voltage marked with this symbol is DC voltage.	
	Caution. Consult Instructions for use : This symbol instructs the user to consult the user manual for further safety related information.	

WARNING

- To reduce the risk of fire or electric shock, do not expose this appliance to rain or moisture.
- To prevent injury, this apparatus must be securely attached to the floor/wall in accordance with the installation instructions.
- This product contains chemicals known to the State of California to cause cancer and birth defects or other reproductive harm.

CAUTION

- Do not expose this apparatus to dripping or splashing. Do not put objects filled with liquids, such as vases, on the apparatus.
- To turn this apparatus off completely, you must pull the power plug out of the wall socket. Consequently, the power plug must be easily and readily accessible at all times.

FCC NOTE (for U.S.A):

Class B FCC Statement

The included module(s) has been tested and found to comply with the limits for a Class B digital device, pursuant to Part 15 of the FCC Rules. These limits are designed to provide reasonable protection against harmful interference in a residential installation. This equipment generates, uses and can radiate radio frequency energy and, if not installed and used in accordance with the instructions, may cause harmful interference to radio communications. However, there is no guarantee that interference will not occur in a particular installation. If this equipment does cause harmful interference to radio or television reception, which can be determined by turning the equipment off and on, the user is encouraged to try to correct the interference by one of the following measures:

- Reorienting or relocating the receiving antenna.
- Increasing the separation between the equipment and receiver.
- Connecting the equipment to an outlet that is on a different circuit than the radio or TV.
- Consulting the dealer or an experienced radio/TV technician for help.

FCC Radiation Exposure Statement :

This equipment complies with FCC radiation exposure limits set forth for an uncontrolled environment.

This equipment should be installed and operated so there is at least 8 inches (20 cm) between the radiator and your body. This device and its antenna(s) must not be co-located or operated in conjunction with any other antenna or transmitter.

FCC Caution :

- Any changes or modifications not expressly approved by the party responsible for compliance could void the user’s authority to operate this equipment. This device complies with Part 15 of the FCC Rules. Operation is subject to the following two conditions: (1) This device may not cause harmful interference, and (2) this device must accept any interference received, including interference that may cause undesired operation.
- This product satisfies FCC regulations when shielded cables and connectors are used to connect the unit to other equipment. To prevent electromagnetic interference with electric appliances, such as radios and televisions, use shielded cables and connectors for connections.

Important Safety Instructions

Read these operating instructions carefully before using the unit. Follow all the safety instructions listed below. Keep these operating instructions handy for future reference.

1. Read these instructions.
2. Keep these Instructions.
3. Heed all warnings.
4. Follow all instructions.
5. Do not use this apparatus near water.
6. Clean only with a dry cloth.
7. Do not block any ventilation openings.
Install in accordance with the manufacturer’s instructions.
8. Do not install near any heat sources such as radiators, heat registers, stoves, or other apparatus (including amplifiers) that produce heat.
9. Do not defeat the safety purpose of the polarized or grounding-type plug.
A polarized plug has two blades with one wider than the other. A grounding type plug has two blades and a third grounding prong. The wide blade or the third prong are provided for your safety. If the provided plug does not fit into your outlet, consult an electrician for replacement of the obsolete outlet.
10. Protect the power cord from being walked on or pinched particularly at plugs, convenience receptacles, and the point where they exit from the apparatus.
11. Only use attachments/accessories specified by the manufacturer.

12. Use only with the cart, stand, tripod, bracket, or table specified by the manufacturer, or sold with the apparatus.



When a cart is used, use caution when moving the cart/apparatus combination to avoid injury from tip-over.

13. Unplug this apparatus during lightning storms or when unused for long periods of time.
14. Refer all servicing to qualified service personnel. Servicing is required when the apparatus has been damaged in any way, such as when the power-supply cord or plug is damaged, liquid has been spilled or objects have fallen into the apparatus, the apparatus has been exposed to rain or moisture, does not operate normally, or has been dropped.

PRECAUTIONS

1. Ensure that the AC power supply in your house complies with the power requirements listed on the identification sticker located on the bottom of your product. Install your product horizontally, on a suitable base (furniture), with enough space around it for ventilation (3-4 inches). Make sure the ventilation slots are not covered. Do not place the unit on amplifiers or other equipment which may become hot. This unit is designed for continuous use. To fully turn off the unit, disconnect the AC plug from the wall outlet. Unplug the unit if you intend to leave it unused for a long period of time.
2. During thunderstorms, disconnect the AC plug from the wall outlet. Voltage peaks due to lightning could damage the unit.
3. Do not expose the unit to direct sunlight or other heat sources. This could lead to overheating and cause the unit to malfunction.
4. Protect the product from moisture (i.e. vases), and excess heat (e.g. a fireplace) or equipment creating strong magnetic or electric fields. Unplug the power cord from the AC wall socket if the unit malfunctions. Your product is not intended for industrial use. It is for personal use only. Condensation may occur if your product has been stored in cold temperatures. If transporting the unit during the winter, wait approximately 2 hours until the unit has reached room temperature before using.
5. The battery used with this product contains chemicals that are harmful to the environment. Do not dispose of the battery in the general household trash. Do not expose the battery to excess heat, direct sunlight, or fire. Do not short circuit, disassemble, or overheat the battery. Danger of explosion if the battery is replaced incorrectly. Replace only with the same or equivalent type.

ABOUT THIS MANUAL

The user manual has two parts: this simple paper USER MANUAL and a detailed FULL MANUAL you can download.



USER MANUAL

See this manual for safety instructions, product installation, components, connections, and product specifications.



FULL MANUAL

You can access the FULL MANUAL on Samsung's on-line customer support center by scanning the QR code. To see the manual on your PC or mobile device, download the manual in document format from Samsung's website.

(<http://www.samsung.com/support>)

Design and specifications are subject to change without prior notice.

CONTENTS

01	Checking the Components	8
	Inserting battery into the Remote Control	8
02	Product Overview	9
	Front / Right Side Panel of the Soundbar	9
	Bottom Panel of the Soundbar	10
03	The Remote Control	11
	Adjusting the Soundbar volume with a TV remote control	12
04	Connecting the Soundbar	14
	Connecting Electrical Power	14
05	Connecting to a TV	15
	Connecting using an Optical Cable	15
	Connecting a TV or Bluetooth Device via Bluetooth	17
06	Connecting an External Device	19
	Connecting using an Optical Cable	19
	Connecting using an Analog Audio (AUX) Cable	20
07	Connecting a USB Storage Device	21
	Setting Repeat Play Options	22
	Software Update	22

08	Installing the Wall Mount (Optional)	23
	Installation Precautions	23
	Wall mount Components	23
09	Troubleshooting	26
10	License	27
11	Open Source License Notice	27
12	Important Notes About Service	27
13	Specifications and Guide	28
	Specifications	28

01 CHECKING THE COMPONENTS

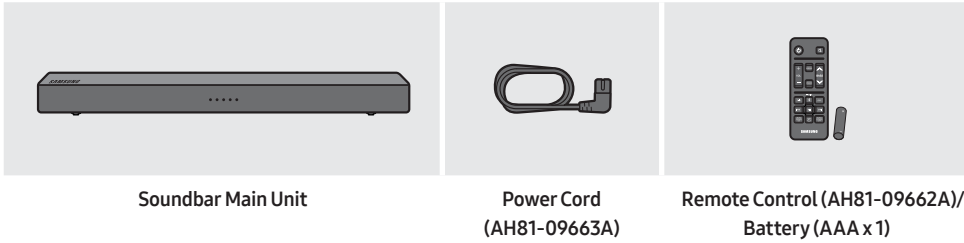

- User Manual / Warranty Card / Regulatory Guide (Not available in some locations).
- For more information about the power supply and power consumption, refer to the label attached to the product. (Label : Bottom of the Soundbar Main Unit)
- To purchase additional components or optional cables, contact a Samsung Service Center or Samsung Customer Care.

Inserting battery into the Remote Control

Match the polarity of the battery to the symbols on the battery compartment.

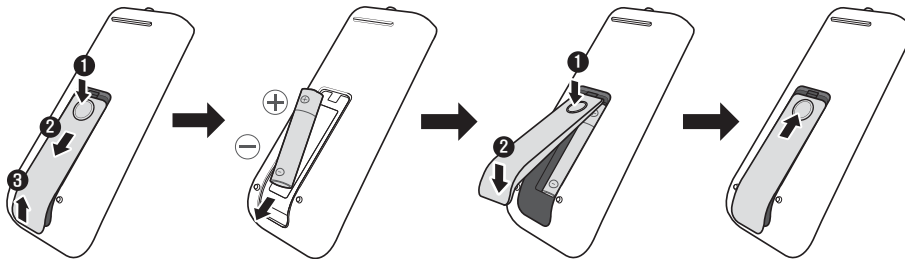

02 PRODUCT OVERVIEW

Front / Right Side Panel of the Soundbar

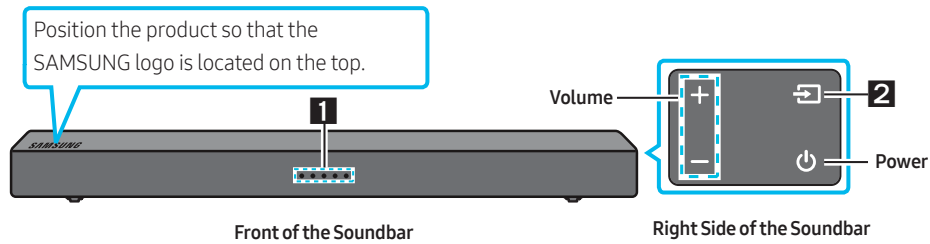

1	LED indicator	The LED Indicator flashes, glows, or changes color depending on the Soundbar's current mode or status. The color of the LED indicator and the number of lights indicate the active mode as described below.		
		<div style="display: flex; justify-content: space-around; align-items: center;"> W White LED B Blue LED R Red LED G Green LED </div>		
		Mode	Remote control Button	LED indicator
		D.IN		W ○ ○ ○ ○
		Bluetooth		B ○ ○ ○ ○ Connected status
				<div style="border: 1px solid blue; padding: 2px; display: inline-block;">Slow-Blinking</div> B ○ ○ ○ ○ Disconnected status
Bluetooth pairing		<div style="border: 1px solid blue; padding: 2px; display: inline-block;">Fast-Blinking</div> B ○ ○ ○ ○		
AUX		W W ○ ○ ○ ○		
USB		W W W ○ ○		
2	Source	Selects the source input mode. (D.IN / Bluetooth / AUX / USB) <ul style="list-style-type: none"> To turn on "Bluetooth pairing" mode, change the source to "Bluetooth" mode and then press and hold the button for more than 5 seconds. 		

Bottom Panel of the Soundbar

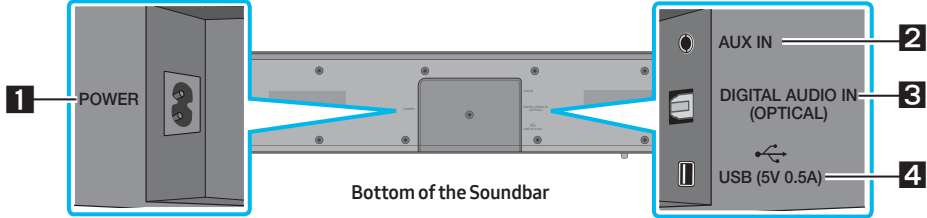

1	POWER	Connect the Soundbar's AC power cord.
2	AUX	Connect to the Analog output of an external device.
3	D.IN	Connect to the digital (optical) output of an external device.
4	USB	Connect a USB device here to play music files on the USB device through the Soundbar.

03 THE REMOTE CONTROL

- The images, buttons, and functions of the remote control may differ depending on the model.

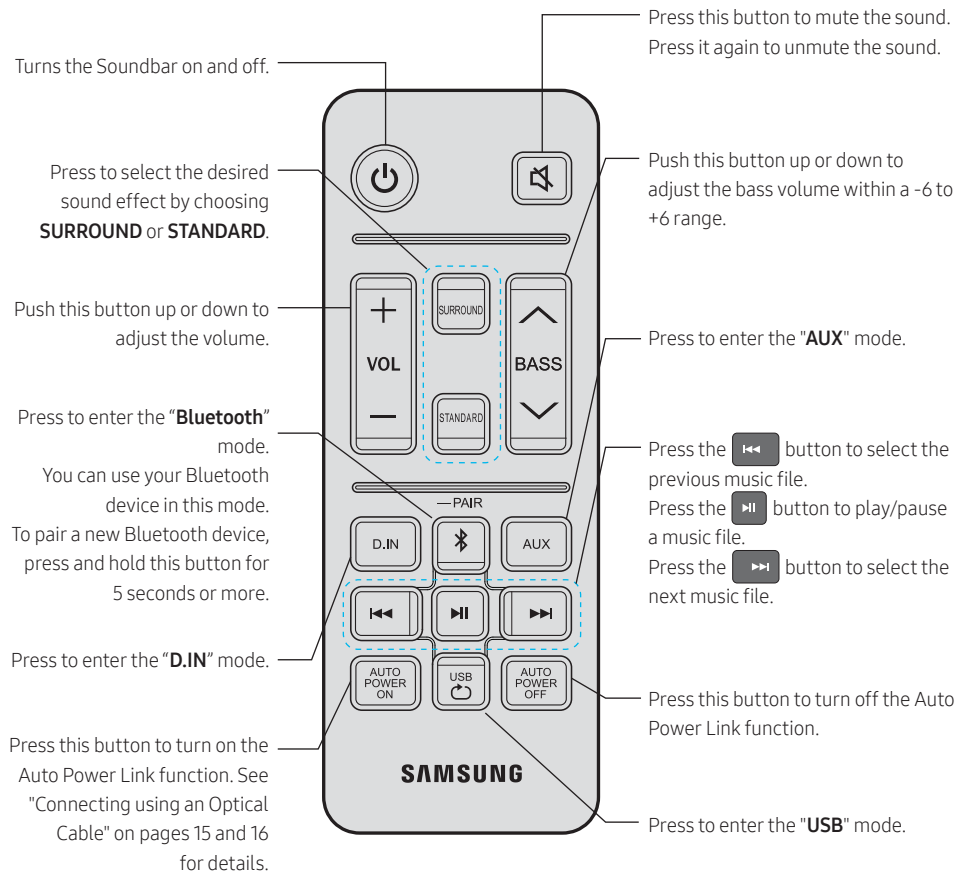









Adjusting the Soundbar volume with a TV remote control

If you have a Samsung TV, you can adjust the Soundbar's volume using the IR remote control that came with your Samsung TV.

First use the TV menu to set the TV audio on your Samsung TV to external speakers, then use your Samsung remote to control the Soundbar's volume. For more information, see the TV's user manual.

The default mode for this function is control by a Samsung TV.

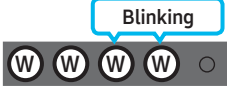
1. If your TV is not a Samsung TV and you want your TV's remote to control the Soundbar's volume, you can change the settings of this function by pressing and holding the **BASS**  button repeatedly. To have your TV's remote adjust the Soundbar's volume, follow Steps 1 through 3 below.
2. If you want to turn off this function completely, follow Steps 1 and 2.

	Mode	Remote control Button	LED indicator
1.	Turn off		
2.	"OFF" mode		
3.	"All TV" mode		
4.	"Samsung TV" mode (Default mode)		

- Each time you press the **BASS**  button and hold it for 5 seconds, the mode switches in the following order: **"Samsung TV"** (Default mode) → **"OFF"** → **"All TV"**.
- The LED's blink for 3~4 seconds, then return to the standby power off mode.
- This function may not be available, depending on your TV's remote control.
- For a list of manufacturers that support this feature, refer to the FULL MANUAL of your Soundbar on the Samsung web site (www.samsung.com/support).

- This volume control function works with IR TV remotes only. It does not work with Bluetooth TV remotes (remotes that require pairing).

NOTE

- Not all TV manufacturers support this feature. For a list of manufacturers that do support this feature, refer to the FULL MANUAL of your Soundbar on the Samsung web site (www.samsung.com/support).

04 CONNECTING THE SOUNDBAR

Connecting Electrical Power

- For information about the required electrical power and power consumption, refer to the label attached to the product. (Label : Bottom of the Soundbar Main Unit)

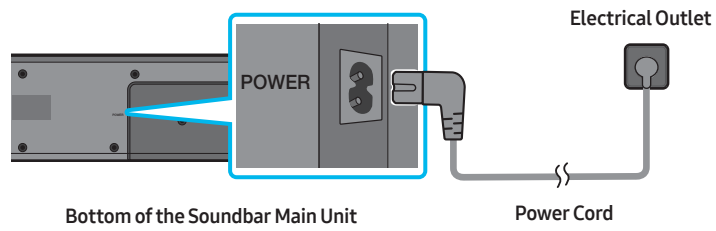

05 CONNECTING TO A TV

Hear TV sound from your Soundbar through wired or wireless connections.

- When the Soundbar is connected to selected Samsung TVs, you can control the Soundbar using the TV's remote control.
 - This feature is supported by 2017 and later Samsung Smart TVs that support Bluetooth when you connect the Soundbar to the TV using an optical cable.
 - This function also allows you to use the TV menu to adjust the sound field and various settings as well as the volume and mute.

Connecting using an Optical Cable

Step 1. Connect an Optical Cable

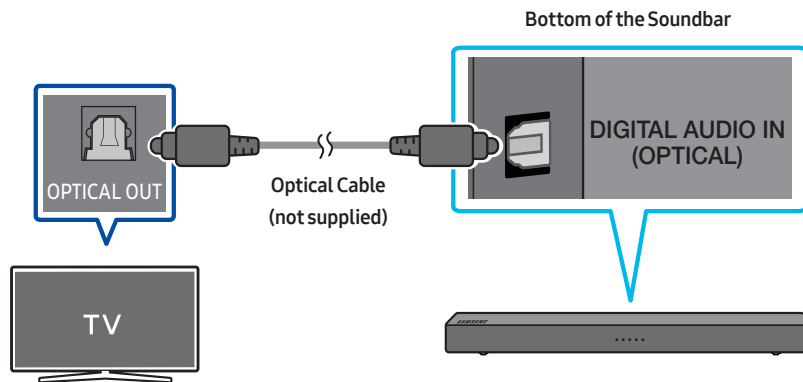

NOTE

- When the audio in a broadcast is encoded in Dolby Digital and the “Digital Output Audio Format” on your TV is set to PCM, we recommend that you change the setting to Dolby Digital. When the setting on the TV is changed, you will experience better sound quality. (The TV menu may use different words for Dolby Digital and PCM depending on the TV manufacturer.)

Step 2. Change the Soundbar's mode to D.IN

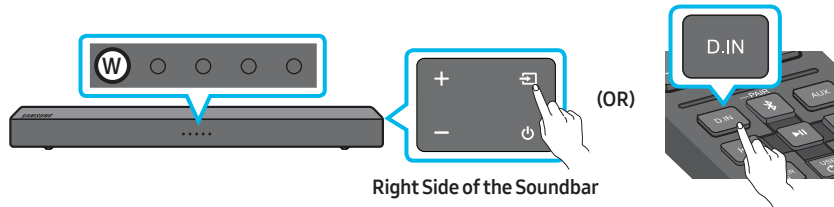





Auto Power Link

This Function automatically turns on the Soundbar when the TV is turned on if the Soundbar is connected to the TV by an Optical Cable (not supplied).

Press the  button on the remote control to turn on this function.

- Auto Power Link is set to ON by default. (To turn off this function, press the  button on the remote control.)
- Depending on the connected device, Auto Power Link may not function.
- This function is only available in the "D.IN" mode.

Mode	Remote control Button	LED indicator
OFF		
ON		

Connecting a TV or Bluetooth Device via Bluetooth

Step 1. Change the Soundbar mode to “Bluetooth Pairing”

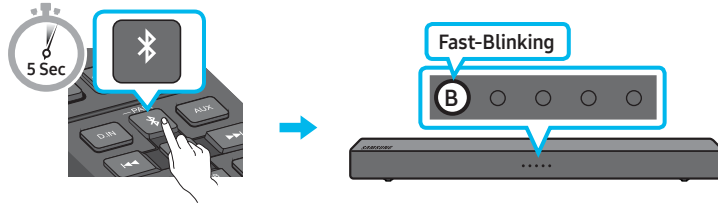

Step 2. Select the Soundbar in your TV's or Bluetooth device's Menu

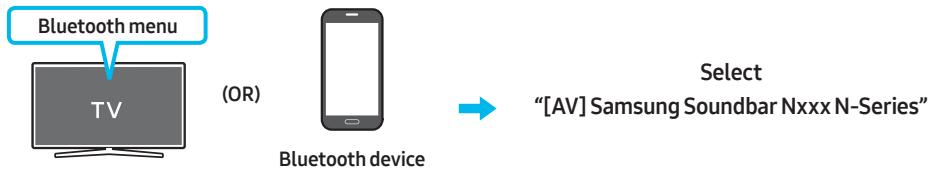

NOTE

- You cannot connect more than one TV or Bluetooth device at a time.

Step 3. Check the Soundbar's status

The blue LED should not be blinking once the Bluetooth connection is complete.

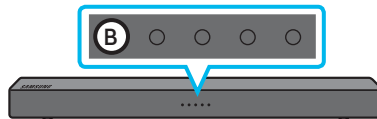





If the TV or device fails to connect

- If a previously connected Soundbar listing appears in the device list of your TV or Bluetooth device, delete it. (e.g. “[AV] Samsung Soundbar Nxxx N-Series”)
- Then repeat steps 1 through 3.

Disconnecting the Soundbar from the TV

Press the  button on the right side panel or on the remote control and switch to any mode but **"Bluetooth"**.

- Disconnecting takes time because the TV must receive a response from the Soundbar. (The time required may differ, depending on the TV model.)
- To cancel the automatic Bluetooth connection between the Soundbar and TV, press and hold  button for 5 seconds in **"Bluetooth"** mode. TV Connect is turned OFF.
- To turn TV Connect back on, press and hold the  button for 5 seconds with the Soundbar in **"Bluetooth"** mode.
- TV Connect is set to ON by default.

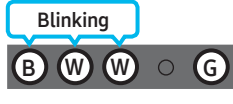
Mode	Remote control Button	LED indicator
TV Connect-OFF		
TV Connect-ON		

NOTES

- If asked for a PIN code when connecting a Bluetooth device, enter <0000>.
- In Bluetooth connection mode, the Bluetooth connection will be lost if the distance between the Soundbar and the Bluetooth device exceeds 32.8 ft.
- The Soundbar automatically turns off after 5 minutes in the Ready state.
- The Soundbar may not perform Bluetooth search or connection correctly under the following circumstances:
 - If there is a strong electrical field around the Soundbar.
 - If several Bluetooth devices are simultaneously paired with the Soundbar.
 - If the Bluetooth device is turned off, not in place, or malfunctions.
- Electronic devices may cause radio interference. Devices that generate electromagnetic waves must be kept away from the Soundbar main unit - e.g., microwaves, wireless LAN devices, etc.

06 CONNECTING AN EXTERNAL DEVICE

Connect to an external device via an optical cable or analog cable to play the external device's sound through the Soundbar.

Connecting using an Optical Cable

Step 1. Connect using an Optical Cable

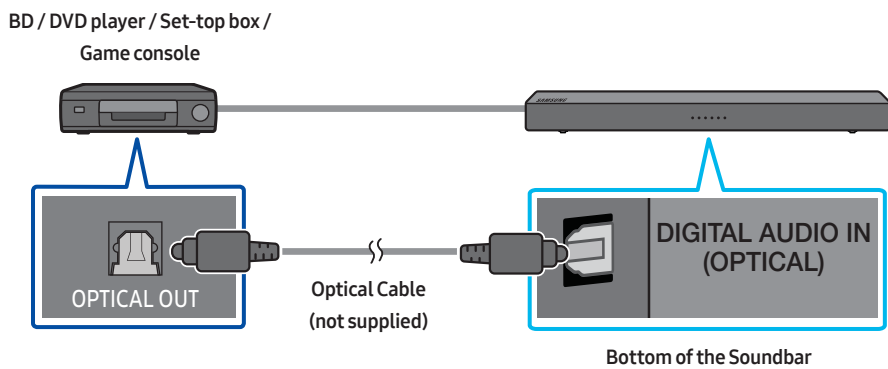

Step 2. Change the Soundbar's mode to D.IN

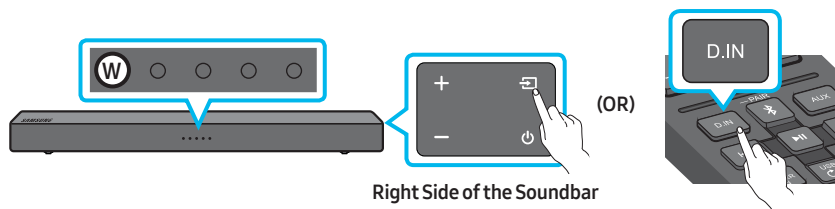

Connecting using an Analog Audio (AUX) Cable

Step 1. Connect using an Analog Audio (AUX) Cable

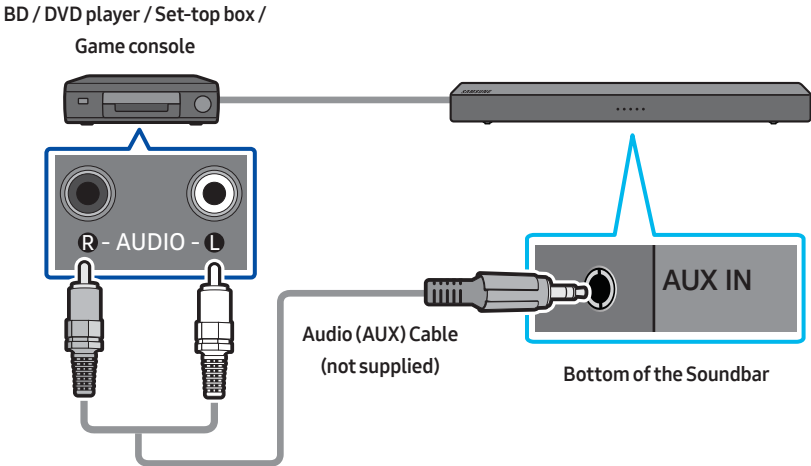

Step 2. Change the Soundbar's mode to AUX

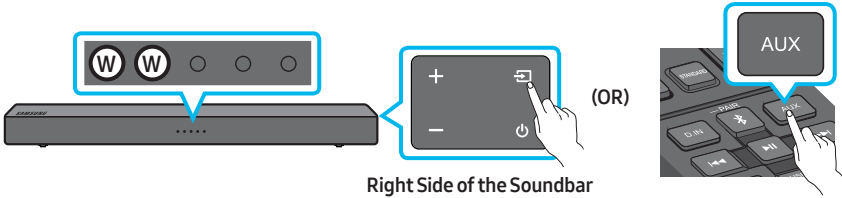

07 CONNECTING A USB STORAGE DEVICE

Step 1. Connect a USB Drive

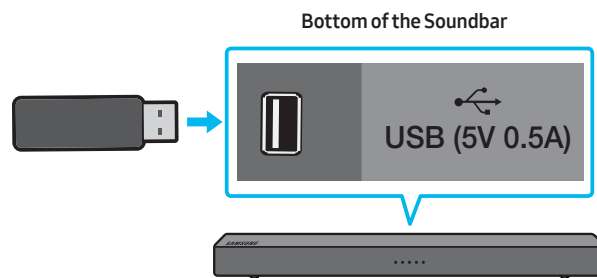

NOTE





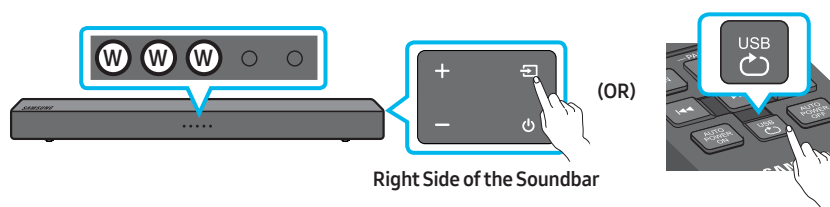

- The Soundbar automatically turns off (Auto Power Off) if you do not connect a USB device to the Soundbar within 5 minutes.

Step 2. Change the Soundbar's mode to USB

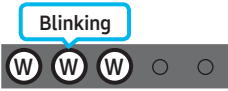

Setting Repeat Play Options

When the Soundbar is in “USB” mode, each time you press the  button the “USB” mode changes how it plays tracks in the following order: **Repeat - Off** > **Repeat - 1 song** > **Repeat - All songs** > **Repeat - Random**. See the table below for details.

Mode	Remote control Button	LED indicator
Repeat - Off		
Repeat - 1 song		
Repeat - All songs		
Repeat - Random		

Software Update

Samsung may offer updates for the Soundbar’s system firmware in the future.

If an update is offered, you can update the firmware by connecting a USB device with the firmware update stored on it to the USB port on your Soundbar. For more information about how to download update files, go to the Samsung Electronics website at (www.samsung.com → Support).

Then, enter or select the model number of your Soundbar, select the Software & Apps option, and then Downloads. Note that the option names can vary.

08 INSTALLING THE WALL MOUNT (OPTIONAL)

Installation Precautions

- Install on a vertical wall only.
- Do not install in a place with high temperature or humidity.
- Verify whether the wall is strong enough to support the product's weight. If not, reinforce the wall or choose another installation point.
- Purchase and use the fixing screws or anchors appropriate for the kind of wall you have (plaster board, iron board, wood, etc.).
If possible, fix the support screws into wall studs.
- Purchase wall mounting screws according to the type and thickness of the wall you want to mount the Soundbar on.
 - Diameter: M4
 - Length: 1.37 inches or longer recommended.
- Connect cables from the unit to external devices before you install the Soundbar on the wall.
- Make sure the unit is turned off and unplugged before you install it. Otherwise, it may cause an electric shock.

Wall mount Components

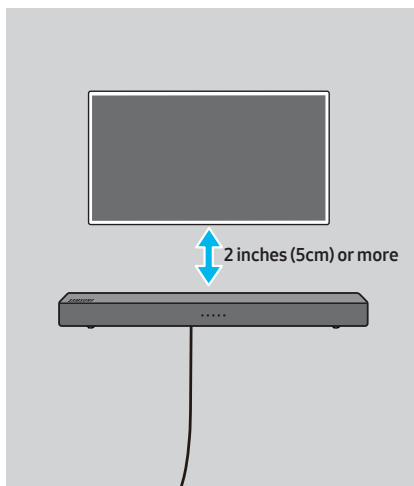

For Installation on Concrete Walls (not supplied)

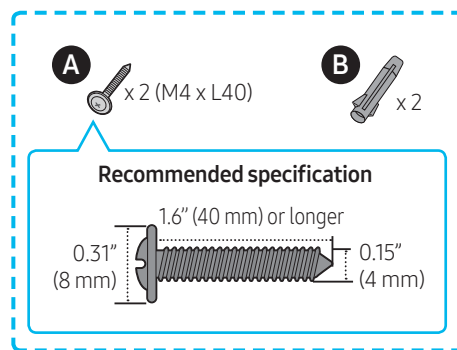

NOTE

- Installations on other types of walls will require different kinds of screws.

1.

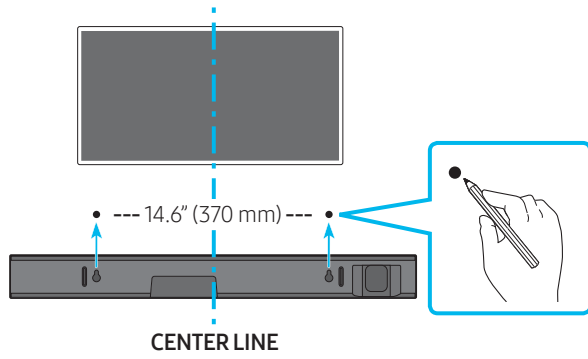

NOTES

- If your TV is installed on the wall, install the Soundbar 2 inches (5cm) or more below your TV.
- Use a pencil to mark the holes' positions.

2.

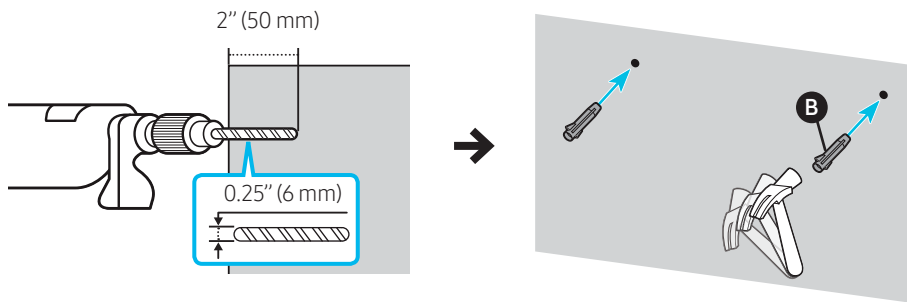

IMPORTANT NOTE

- The installation method shown here is for CONCRETE walls. Installation methods will vary depending on the wall type. For installation on dry wall, we strongly recommend you drill screw support holes into the underlying wood studs.

3.

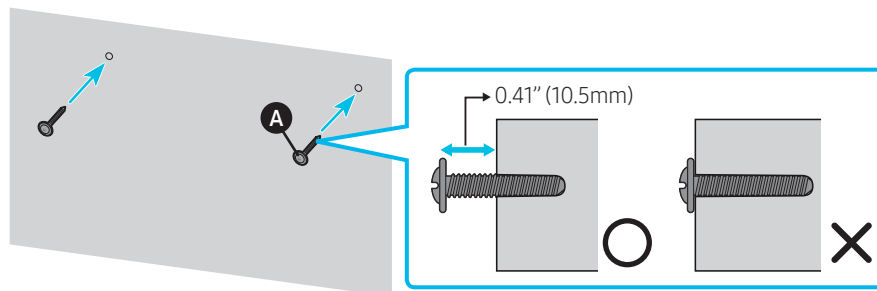

4.

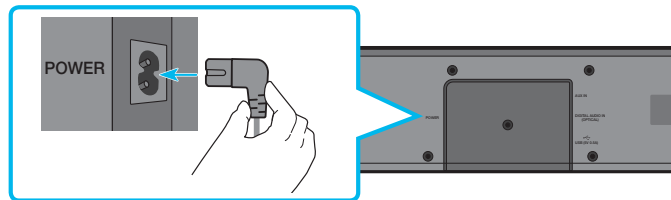

5.

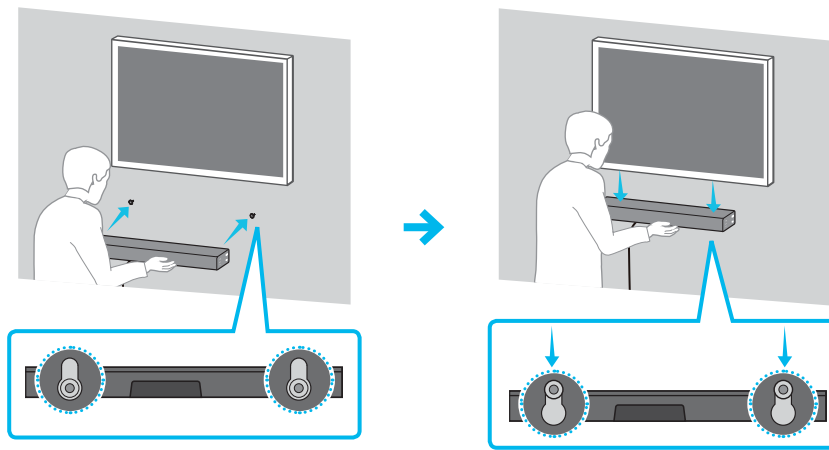

NOTE

- Supports for wall installation are built into the back of the Soundbar.

⚠ CAUTION

- Press the Soundbar down with sufficient force to fix it to the wall. If the Soundbar is not firmly fixed to the wall, it could be accidentally detached, resulting in personal injury.
- Do not bump into or strike the Soundbar (especially from the bottom). The impact could detach the Soundbar from the wall, resulting in personal injury.

09 TROUBLESHOOTING

Refer to the table below if this product does not function properly. If the problem you are experiencing is not listed below or if the instructions below do not help, turn off the product, disconnect the power cord, and contact Samsung Electronics at 1-800-SAMSUNG (1-800-726-7864).

The unit will not turn on.

Is the power cord plugged into an outlet?

- Connect the power plug to an outlet.

A function does not work when the button is pressed.

Is there static electricity in the air?

- Disconnect the power plug and connect it again.

Sound dropouts occur in Bluetooth mode.

- See the Bluetooth connection sections on pages 17 and 18.

Sound is not produced.

Is the Mute function on?

- Press the **VOL** button to cancel the function.

Is the volume set to minimum?

- Adjust the Volume.

The remote control does not work.

Is the battery drained?

- Replace with new batteries.

Is the distance between the remote control and Soundbar main unit too far?

- Move the remote control closer to the Soundbar main unit.

10 LICENSE



Manufactured under license from Dolby Laboratories. Dolby, Dolby Audio, Pro Logic, and the double-D symbol are trademarks of Dolby Laboratories.



For DTS patents, see <http://patents.dts.com>.
Manufactured under license from DTS Licensing Limited. DTS, the Symbol, DTS in combination with the Symbol, and DTS 2.0 Channel are registered trademarks or trademarks of DTS, Inc. in the United States and/or other countries. © DTS, Inc. All Rights Reserved.

11 OPEN SOURCE LICENSE NOTICE

To send inquiries and requests regarding open sources, contact Samsung via Email (oss.request@samsung.com).

12 IMPORTANT NOTES ABOUT SERVICE

- Figures and illustrations in this User Manual are provided for reference only and may differ from actual product appearance.
- An administration fee may be charged if either:
 - a. An engineer is called out to your home at your request and there is no defect in the product.
 - b. You bring the unit to a repair center and there is no defect in the product.
- You will be advised of the amount of the administration fee before any work is done or a home visit is made.
- If you have a problem with this product, we strongly recommend you read the appropriate section of this manual, visit the Support page for your product at www.samsung.com, or call Samsung Product Support (1-800-726-7864) to find an answer before you contact a service center for a repair.

13 SPECIFICATIONS AND GUIDE

Specifications

Model Name	HW-N300
USB	5V/0.5A
Weight	4.4 lbs (2.0 kg)
Dimensions (W x H x D)	25.2 x 2.6 x 4.2 inches (641.0 x 65.0 x 107.0 mm)
Operating Temperature Range	+41°F to +95°F (+5°C to +35°C)
Operating Humidity Range	10 % ~ 75 %
Supported play formats (DTS 2.0 sound is played in DTS format.)	LPCM 2ch, Dolby Audio™ (supporting Dolby® Digital), DTS

NOTES

- Samsung Electronics Co., Ltd reserves the right to change the specifications without notice.
- Weight and dimensions are approximate.
- Dispose unwanted electronics through an approved recycler.
To find the nearest recycling location, go to our website: www.samsung.com/recyclingdirect or call (877) 278 - 0799

LIMITED WARRANTY TO ORIGINAL PURCHASER

This SAMSUNG brand product, as supplied and distributed by SAMSUNG and delivered new, in the original carton to the original consumer purchaser, is warranted by SAMSUNG against manufacturing defects in materials and workmanship for a limited warranty period of:

One (1) Year Parts and Labor*

(*90 Days Parts and Labor for Commercial Use)

This limited warranty begins on the original date of purchase, and is valid only on products purchased and used in the United States. To receive warranty service, the purchaser must contact SAMSUNG for problem determination and service procedures. Warranty service can only be performed by a SAMSUNG authorized service center. The original dated bill of sale must be presented upon request as proof of purchase to SAMSUNG or SAMSUNG's authorized service center. Transportation of the product to and from the service center is the responsibility of the purchaser.

SAMSUNG will repair or replace this product, at our option and at no charge as stipulated herein, with new or reconditioned parts or products if found to be defective during the limited warranty period specified above.

All replaced parts and products become the property of SAMSUNG and must be returned to SAMSUNG.

Replacement parts and products assume the remaining original warranty, or ninety (90) days, whichever is longer.

SAMSUNG's obligations with respect to software products distributed by SAMSUNG under the SAMSUNG brand name are set forth in the applicable end user license agreement. Non-SAMSUNG hardware and software products, if provided, are on an "AS IS" basis.

Non-SAMSUNG manufacturers, suppliers, publishers, and service providers may provide their own warranties.

This limited warranty covers manufacturing defects in materials and workmanship encountered in normal, and except to the extent otherwise expressly provided for in this statement, noncommercial use of this product, and shall not apply to the following, including, but not limited to: damage which occurs in shipment; delivery and installation; applications and uses for which this product was not intended; altered product or serial numbers; cosmetic damage or exterior finish; accidents, abuse, neglect, fire, water, lightning or other acts of nature; use of products, equipment, systems, utilities, services, parts, supplies, accessories, applications, installations, repairs, external wiring or connectors not supplied and authorized by SAMSUNG, or which damage this product or result in service problems; incorrect electrical line voltage, fluctuations and surges; customer adjustments and failure to follow operating instructions, cleaning, maintenance and environmental instructions that are covered and prescribed in the instruction book; product removal or reinstallation; reception problems and distortion related to noise, echo, interference or other signal transmission and delivery problems. SAMSUNG does not warrant uninterrupted or error-free operation of the product.

THERE ARE NO EXPRESS WARRANTIES OTHER THAN THOSE LISTED AND DESCRIBED ABOVE, AND NO WARRANTIES WHETHER EXPRESS OR IMPLIED, INCLUDING, BUT NOT LIMITED TO, ANY IMPLIED WARRANTIES OF MERCHANTABILITY OR FITNESS FOR A PARTICULAR PURPOSE, SHALL APPLY AFTER THE EXPRESS WARRANTY PERIODS STATED ABOVE, AND NO OTHER EXPRESS WARRANTY OR GUARANTY GIVEN BY ANY PERSON, FIRM OR CORPORATION WITH RESPECT TO THIS PRODUCT SHALL BE BINDING ON SAMSUNG. SAMSUNG SHALL NOT BE LIABLE FOR LOSS OF REVENUE OR PROFITS, FAILURE TO REALIZE SAVINGS OR OTHER BENEFITS, OR ANY OTHER SPECIAL, INCIDENTAL OR CONSEQUENTIAL DAMAGES CAUSED BY THE USE, MISUSE OR INABILITY TO USE THIS PRODUCT, REGARDLESS OF THE LEGAL THEORY ON WHICH THE CLAIM IS BASED, AND EVEN IF SAMSUNG HAS BEEN ADVISED OF THE POSSIBILITY OF SUCH DAMAGES. NOR SHALL RECOVERY OF ANY KIND AGAINST SAMSUNG BE GREATER IN AMOUNT THAN THE PURCHASE PRICE OF THE PRODUCT SOLD BY SAMSUNG AND CAUSING THE ALLEGED DAMAGE. WITHOUT LIMITING THE FOREGOING, PURCHASER ASSUMES ALL RISK AND LIABILITY FOR LOSS, DAMAGE OR INJURY TO PURCHASER AND PURCHASER'S PROPERTY AND TO OTHERS AND THEIR PROPERTY ARISING OUT OF THE USE, MISUSE OR INABILITY TO USE THIS PRODUCT SOLD BY SAMSUNG NOT CAUSED DIRECTLY BY THE NEGLIGENCE OF SAMSUNG. THIS LIMITED WARRANTY SHALL NOT EXTEND TO ANYONE OTHER THAN THE ORIGINAL PURCHASER OF THIS PRODUCT, IS NONTRANSFERABLE AND STATES YOUR EXCLUSIVE REMEDY.

Some states do not allow limitations on how long an implied warranty lasts, or the exclusion or limitation of incidental or consequential damages, so the above limitations or exclusions may not apply to you. This warranty gives you specific legal rights, and you may also have other rights which vary from state to state.

To obtain warranty service, please contact SAMSUNG customer care center.

The benefits of this Limited Warranty extend only to the original purchaser of Samsung products from an authorized Samsung reseller. THIS LIMITED WARRANTY SHALL NOT APPLY TO ANY SAMSUNG PRODUCTS PURCHASED FROM UNAUTHORIZED RESELLERS OR RETAILERS, EXCEPT IN STATES WHERE SUCH RESTRICTION MAY BE PROHIBITED. For a list of Samsung authorized retailers, please go to:

http://www.samsung.com/us/peaceofmind/authorized_resellers.html

SAMSUNG

The party responsible for product compliance:
Samsung Electronics Co., LTD.
America QA lab of Samsung
19 Chapin Rd. Building D,
Pine Brook, New Jersey 07058

QUESTIONS OR COMMENTS?

COUNTRY	CALL	OR VISIT US ONLINE AT	WRITE
IN THE US	1-800-SAMSUNG (726-7864)	www.samsung.com/us/support	Samsung Electronics America, Inc. 85 Challenger Road Ridgefield Park, NJ 07660

© 2018 Samsung Electronics Co., Ltd. All rights reserved.



72-SAMUSA-MANB1-SS



72-SAMUSA-MANB1-SS