

SCX-483x Series
SCX-563x Series
SCX-573x Series

User's Guide

Basic

imagine the possibilities

This guide provides information concerning installation, basic operation and troubleshooting on windows



1. Introduction

- 5 **Key benefits**
- 7 **Features by models**
- 8 **Useful to know**
- 9 **About this user's guide**
- 10 **Safety information**
- 16 **Machine overview**
- 19 **Control panel overview**
- 25 **Turning on the machine**
- 26 **Installing the driver locally**
- 27 **Reinstalling the driver**



2. Menu overview and basic setup

- 29 **Menu overview**
- 34 **Changing the display language**
- 35 **Media and tray**
- 51 **Basic printing**
- 57 **Basic copying**
- 62 **Basic scanning**
- 63 **Basic faxing**
- 68 **Using USB memory device**



3. Maintenance

- 75 **Ordering supplies and accessories**
- 76 **Available supplies**
- 77 **Available accessories**
- 79 **Available maintenance parts**
- 80 **Redistributing toner**
- 82 **Replacing the toner cartridge**
- 84 **Upgrading a memory module**
- 86 **Monitoring the supplies life**
- 87 **Setting the toner low alert**
- 88 **Cleaning the machine**



4. Troubleshooting

- 93 **Tips for avoiding paper jams**
- 94 **Clearing original document jams**
- 101 **Clearing paper jams**
- 108 **Understanding the status LED**
- 110 **Understanding display messages**



5. **Appendix**

123 **Specifications**

133 **Regulatory information**

146 **Copyright**



1. Introduction

This chapter provides information you need to know before using the machine.

- **Key benefits** 5
- **Features by models** 7
- **Useful to know** 8
- **About this user's guide** 9
- **Safety information** 10
- **Machine overview** 16
- **Control panel overview** 19
- **Turning on the machine** 25
- **Installing the driver locally** 26
- **Reinstalling the driver** 27

Key benefits

Environmentally friendly



- To save toner and paper, this machine supports Eco feature.
- To save paper, you can print multiple pages on one single sheet of paper (see Advanced Guide).
- To save paper, you can print on both sides of the paper (double-sided printing) (see Advanced Guide).
- To save electricity, this machine automatically conserves electricity by substantially reducing power consumption when not in use.

Print with excellent quality and speed



- You can print with a resolution of up to 1,200 x 1,200 dpi effective output.
- Fast, on-demand printing.
SCX-483x Series:
 - For single-side printing, 31 ppm (A4) or 33 ppm (Letter).

- For duplex printing, 15 ppm (A4) or 16 ppm (Letter).
SCX-563x Series or SCX-573x Series:
- For single-side printing, 35 ppm (A4) or 37 ppm (Letter).
- For duplex printing, 17 ppm (A4) or 18 ppm (Letter).

Convenience



- Printing Status (or Smart Panel) is a program that monitors and informs you of the machine's status and allows you to customize the machine's settings (see Advanced Guide).
- AnyWeb Print helps you screen-capture, preview, scrap, and print the screen of Windows Internet Explorer more easily, than when you use the ordinary program (see Advanced Guide).

Key benefits

Wide range of functionality and application support



- Supports various paper sizes (see "Print media specifications" on page 125).
- Print watermark: You can customize your documents with words, such as "Confidential" (see Advanced Guide).
- Print posters: The text and pictures of each page of your document are magnified and printed across the multiple sheets of paper and can then be taped together to form a poster (see Advanced Guide).
- You can print in various operating systems (see "System requirements" on page 128).
- Your machine is equipped with a USB interface and/or a network interface.

Expand your machine's capacity

- This machine has an extra memory slot for adding more memory (see "Available accessories" on page 77).
- Zoran IPS Emulation compatible with PostScript 3 (PS) enables PS printing.



- Zoran IPS Emulation compatible with PostScript 3
- ©1995-2005, Zoran Corporation. All rights reserved. Zoran, the Zoran logo, IPS/PS3, and OneImage are trademarks of Zoran Corporation.
- 136 PS3 fonts
- Contains UFST and MicroType from Monotype Imaging Inc.

Features by models

Some features and optional goods may not be available depending on model or country.

Features	SCX-4833FD SCX-4835FD SCX-4833HD	SCX-4833FR SCX-4835FR	SCX-5637FR SCX-5639FR SCX-5637HR	SCX-5737FW SCX-5739FW
Print, Copy, Scan, Fax	●	●	●	●
Hi-Speed USB 2.0	●	●	●	●
IEEE 1284 Parallel	○	○	○	○
Network Interface Ethernet 10/100 Base TX wired LAN	●			
Network Interface Ethernet 10/100/1000 Base TX wired LAN		●	●	●
Network Interface 802.11b/g/n wireless LAN				●
Eco printing	●	●	●	●
Duplex (2-sided) printing	●	●	●	●
Samsung Easy Printer Manager	●	●	●	●
Memory	○	○	○	○
Tray 2 (520 sheets)	○	○	○	○
SyncThru™ Web Service	●	●	●	●
Automatic Document Feeder (ADF)	●			
Dual Automatic Document Feeder (DADF)		●	●	●

(●: Included, ○: Optional, Blank: Not available)

Useful to know



The machine does not print.

- Open the print queue list and remove the document from the list (see "Canceling a print job" on page 51).
- Remove the driver and install it again (see "Installing the driver locally" on page 26).
- Select your machine as your default machine in your Windows.



Where can I purchase accessories or supplies?

- Inquire at a Samsung distributor or your retailer.
- Visit www.samsung.com/supplies. Select your country/region to view product service information.



The status LED flashes or remains constantly on.

- Turn the product off and on again.
- Check the meanings of LED indications in this manual and troubleshoot accordingly (see "Understanding the status LED" on page 108).



A paper jam has occurred.

- Open and close the front door.
- Check the instructions on removing jammed paper in this manual and troubleshoot accordingly (see "Clearing paper jams" on page 101).



Printouts are blurry.

- The toner level might be low or uneven. Shake the toner cartridge.
- Try a different print resolution setting.
- Replace the toner cartridge.



Where can I download the machine's driver?

- Visit www.samsung.com/printer to download the latest machine's driver, and install it on your system.

This user's guide provides information for your basic understanding of the machine as well as detailed steps to explain machine usage.

- Read the safety information before using the machine.
- If you have a problem using the machine, refer to the troubleshooting chapter.
- Terms used in this user's guide are explained in the glossary chapter.
- All illustrations in this user's guide may differ from your machine depending on its options or model you purchased.
- The procedures in this user's guide are mainly based on Windows 7.
- SCX-4833FD, SCX-4833HD and SCX-4835FD are the same series machine. This User's Guide is written on the basis of SCX-4833FD.
- SCX-4833FR and SCX-4835FR are the same series machine. This User's Guide is written on the basis of SCX-4833FR.
- SCX-5637FR, SCX-5637HR and SCX-5639FR are the same series machine. This User's Guide is written on the basis of SCX-5637FR.
- SCX-5737FW and SCX-5739FW are the same series machine. This User's Guide is written on the basis of SCX-5737FW.





Conventions

Some terms in this guide are used interchangeably, as below:

- Document is synonymous with original.
- Paper is synonymous with media, or print media.
- Machine refers to printer or MFP.



General icons

Icon	Text	Description
	Caution	Gives users information to protect the machine from possible mechanical damage or malfunction.
	Note	Provides additional information or detailed specification of the machine function and feature.

These warnings and precautions are included to prevent injury to you and others, and to prevent any potential damage to your machine. Be sure to read and understand all of these instructions before using the machine. After reading this section, keep it in a safe place for future reference.



Important safety symbols

Explanation of all icons and signs used in this chapter

	Warning	Hazards or unsafe practices that may result in severe personal injury or death.
	Caution	Hazards or unsafe practices that may result in minor personal injury or property damage.
		Do not attempt.



Operating environment

Warning



Do not use if the power cord is damaged or if the electrical outlet is not grounded.

This could result in electric shock or fire.



Do not place anything on top of the machine (water, small metal or heavy objects, candles, lit cigarettes, etc.).

This could result in electric shock or fire.

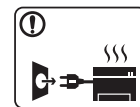

- If the machine gets overheated, it releases smoke, makes strange noises, or generates an odd odor, immediately turn off the power switch and unplug the machine.
- The user should be able to access the power outlet in case of emergencies that might require the user to pull the plug out.

This could result in electric shock or fire.



Do not bend, or place heavy objects on the power cord. Stepping on or allowing the power cord to be crushed by a heavy object could result in electric shock or fire.



Do not remove the plug by pulling on the cord; do not handle the plug with wet hands.
This could result in electric shock or fire.

Caution

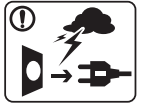

During an electrical storm or for a period of non-operation, remove the power plug from the electrical outlet.
This could result in electric shock or fire.



Be careful, the paper output area is hot.
Burns could occur.



If the machine has been dropped, or if the cabinet appears damaged, unplug the machine from all interface connections and request assistance from qualified service personnel.
Otherwise, this could result in electric shock or fire.



If the plug does not easily enter the electrical outlet, do not attempt to force it in.
Call an electrician to change the electrical outlet, or this could result in electric shock.



Do not allow pets to chew on the AC power, telephone or PC interface cords.
This could result in electric shock or fire and/or injury to your pet.



If the machine does not operate properly after these instructions have been followed, unplug the machine from all interface connections and request assistance from qualified service personnel.
Otherwise, this could result in electric shock or fire.



Operating method







Caution



Do not forcefully pull the paper out during printing.
It can cause damage to the machine.



Be careful not to put your hand between the machine and paper tray.
You may get injured.

	<p>Do not block or push objects into the ventilation opening.</p> <p>This could result in elevated component temperatures which can cause damage or fire.</p>
	<p>Be care when replacing paper or removing jammed paper.</p> <p>New paper has sharp edges and can cause painful cuts.</p>
	<p>When printing large quantities, the bottom part of the paper output area may get hot. Do not allow children to touch.</p> <p>Burns can occur.</p>
	<p>When removing jammed paper, do not use tweezers or sharp metal objects.</p> <p>It can damage the machine.</p>
	<p>Do not allow too many papers to stack up in the paper output tray.</p> <p>It can damage the machine.</p>
	<p>This machine's power reception device is the power cord.</p> <p>To switch off the power supply, remove the power cord from the electrical outlet.</p>



Installation / Moving

Warning

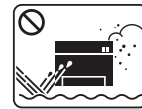

Do not place the machine in an area with dust, humidity, or water leaks.

This could result in electric shock or fire.

Caution









Before moving the machine, turn the power off and disconnect all cords.

Then lift the machine:

- If the machine weighs under 20 kg (44.09 lbs), lift with 1 person.
- If the machine weighs 20 kg (44.09 lbs) - 40kg (88.18 lbs), lift with 2 people.
- If the machine weighs more than 40 kg (88.18 lbs), lift with 4 or more people.

The machine could fall, causing injury or machine damage.

	Do not place the machine on an unstable surface. The machine could fall, causing injury or machine damage.
	The machine should be connected to the power level which is specified on the label. If you are unsure and want to check the power level you are using, contact the electrical utility company.
	Use only No.26 AWG ^a or larger, telephone line cord, if necessary. Otherwise, it can cause damage to the machine.
	Do not put a cover over the machine or place it in an airtight location, such as a closet. If the machine is not well-ventilated, this could result in fire.
	Make sure you plug the power cord into a grounded electrical outlet. Otherwise, this could result in electric shock or fire.
	Do not overload wall outlets and extension cords. This can diminish performance, and could result in electric shock or fire.

	Use the power cord supplied with your machine for safe operation. If you are using a cord which is longer than 2 meters (6 feet) with a 110V machine, then the gauge should be 16 AWG or larger. Otherwise, it can cause damage to the machine, and could result in electric shock or fire.
---	---

a. AWG: American Wire Gauge



Maintenance / Checking







Caution



Unplug this product from the wall outlet before cleaning the inside of the machine. Do not clean the machine with benzene, paint thinner or alcohol; do not spray water directly into the machine. This could result in electric shock or fire.



When you are working inside the machine replacing supplies or cleaning the inside, do not operate the machine. You could get injured.









	<p>Keep the power cable and the contact surface of the plug clean from dust or water. Otherwise, this could result in electric shock or fire.</p>
	<p>Do not remove any covers or guards that are fastened with screws. The machine should only be repaired by a Samsung service technician.</p>
 	<p>Keep cleaning supplies away from children. Children could get hurt.</p>
 	<p>Do not disassemble, repair or rebuild the machine by yourself. It can damage the machine. Call a certified technician when the machine needs repairing.</p>
	<p>To clean and operate the machine, strictly follow the user's guide provided with the machine. Otherwise, you could damage the machine.</p>



Supply usage



Caution

 	<p>Do not disassemble the toner cartridge. Toner dust can be dangerous if inhaled or ingested.</p>
 	<p>Do not burn any of the supplies such as toner cartridge or fuser unit. This could cause an explosion or uncontrollable fire.</p>
	<p>When changing the toner cartridge or removing jammed paper, be careful not to let toner dust touch your body or clothes. Toner dust can be dangerous if inhaled or ingested.</p>
 	<p>When storing supplies such as toner cartridges, keep them away from children. Toner dust can be dangerous if inhaled or ingested.</p>
	<p>Using recycled supplies, such as toner, can cause damage to the machine. In case of damage due to the use of recycled supplies, a service fee will be charged.</p>



When toner gets on your clothing, do not use hot water to wash it.

Hot water sets toner into fabric. Use cold water.



Accessories

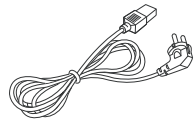

Power cord



Quick installation guide

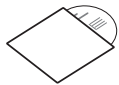

Software CD^a

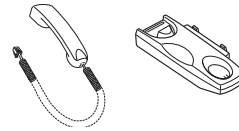

Handset^b

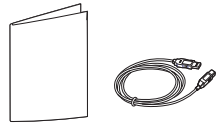

Misc. accessories^c

a. The software CD contains the printer driver and applications.

b. SCX-4833HD and SCX-5637HR only.

c. Miscellaneous accessories included with your machine may vary by country of purchase and specific model.



Front view



- This illustration may differ from your machine depending on its model.
- Some features and optional goods may not be available depending on model or country.

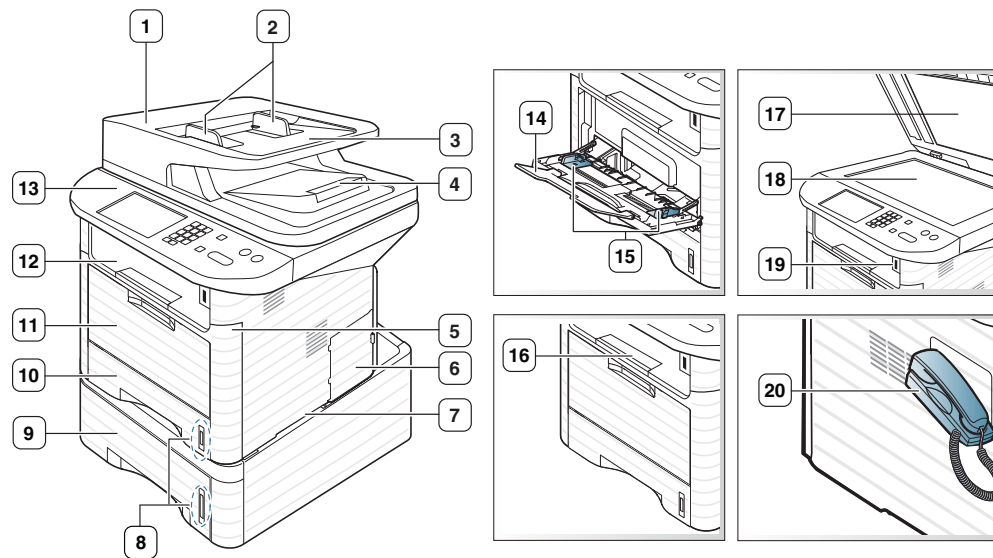

1	Document feeder cover	6	Control board cover	11	Multi-purpose tray	16	Output support
2	Document feeder width guide	7	Handle	12	Output tray	17	Scanner lid
3	Document feeder input tray	8	Paper level indicator	13	Control panel	18	Scanner glass
4	Document feeder output tray	9	Tray 2 (optional)	14	Multi-purpose tray paper extension	19	USB port
5	Front cover	10	Tray 1	15	Paper width guides on a multi-purpose tray	20	Handset



Rear view



- This illustration may differ from your machine depending on its model.
- Some features and optional goods may not be available depending on model or country.

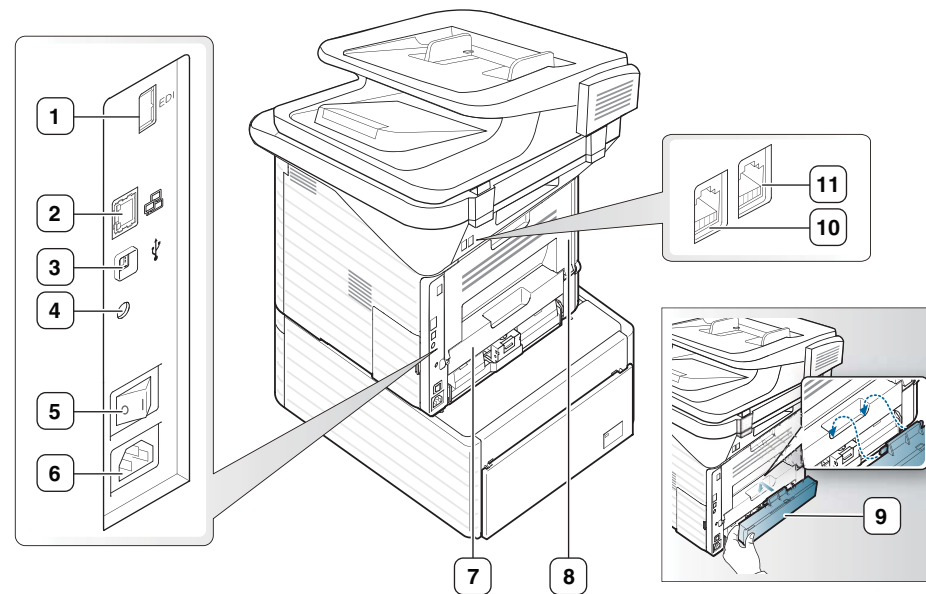

1	EDI port	4	IEEE 1284 parallel connector (optional)	7	Duplex unit	10	Telephone line socket
2	Network port	5	Power-switch	8	Rear cover	11	Extension telephone socket (EXT)
3	USB port	6	Power receptacle	9	Tray back cover		



This control panel may differ from your machine depending on its model. There are various types of control panels.



Type A

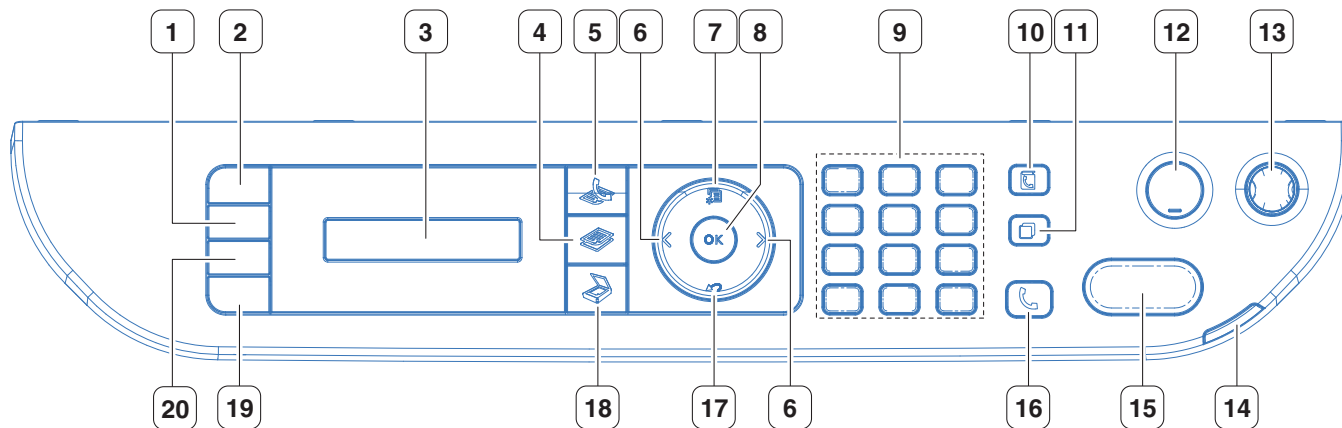

1	Darkness	Adjusts the brightness level to make a copy for easier reading, when the original contains faint markings and dark images.
2	ID Copy	Allows you to copy both sides of the ID card like a driver's license to a single side of paper.
3	Display screen	Shows the current status and prompts during an operation.
4	Copy	Activates Copy mode.
5	Fax	Activates Fax mode.
6	Left/Right Arrows	Scrolls through the options available in the selected menu and increases or decreases values.

7	Menu	Enters Menu mode and scrolls through the available menus.
8	OK	Confirms the selection on the screen.
9	Numeric keypad	Dials a number or enters alphanumeric characters.
10	Address Book	Allows you to store frequently used fax numbers and email addresses or search for stored fax numbers or email addresses.
11	Redial/Pause	Redials the last number in ready mode, or inserts a pause into a fax number in Edit mode.
12	Stop/Clear	Stops an operations at any time.
13	Power	Turn the power on or off, or wake up the machine from the power save mode. If you need to turn the machine off, press this button for more than three seconds. You can also turn the power on, or wake up the machine from power save mode by pressing this button.
14	Status LED	Shows the status of your machine (see "Understanding the status LED" on page 108).
15	Start	Starts a job.
16	On Hook Dial	When you press this button, you can hear a dial tone. Then enter a fax number. It is similar to making a call using speaker phone.
17	Back	Sends you back to the upper menu level.
18	Scan	Activates Scan mode.
19	Eco	Turn into eco mode to reduce toner consumption and paper usage (see "Eco options" on page 55).
20	Direct USB	Allows you to directly print files stored on a USB memory device when it is inserted into the USB port on the front of your machine.



Type B

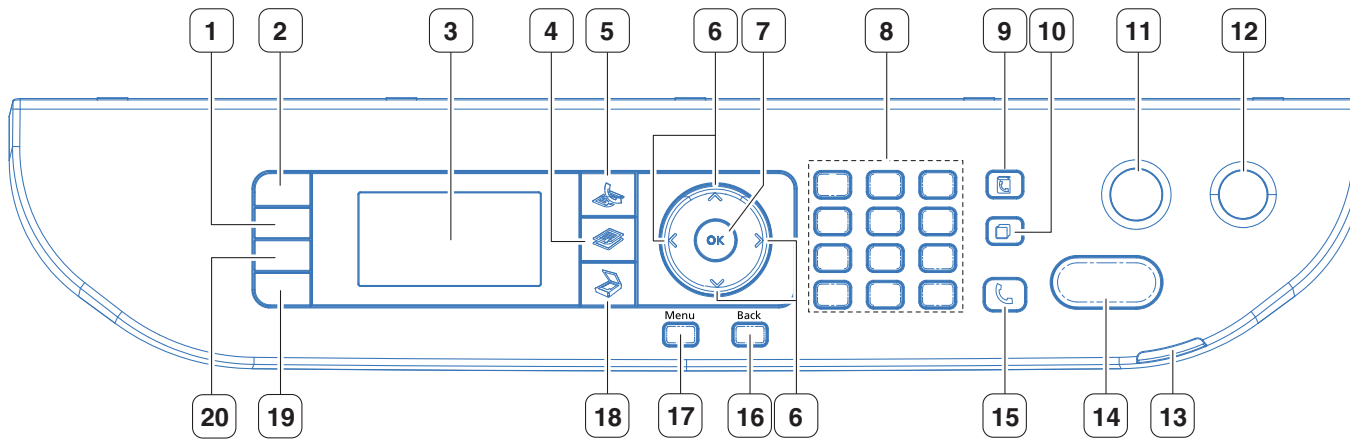

1	Darkness	Adjusts the brightness level to make a copy for easier reading, when the original contains faint markings and dark images.
2	ID Copy	Allows you to copy both sides of the ID card like a driver's license to a single side of paper.
3	Display screen	Shows the current status and prompts during an operation.
4	Copy	Activates Copy mode.
5	Fax	Activates Fax mode.
6	Arrows	Scroll through the options available in the selected menu, and increase or decrease values.
7	OK	Confirms the selection on the screen.
8	Numeric keypad	Dials a number or enters alphanumeric characters.

9	Address Book	Allows you to store frequently used fax numbers and email addresses or search for stored fax numbers or email addresses.
10	Redial/Pause	Redials the last number in ready mode, or inserts a pause into a fax number in Edit mode.
11	Stop/Clear	Stops an operations at any time.
12	Power	Turn the power on or off, or wake up the machine from the power save mode. If you need to turn the machine off, press this button for more than three seconds. You can also turn the power on, or wake up the machine from power save mode by pressing this button.
13	Status LED	Shows the status of your machine (see "Understanding the status LED" on page 108).
14	Start	Starts a job.
15	On Hook Dial	When you press this button, you can hear a dial tone. Then enter a fax number. It is similar to making a call using speaker phone.
16	Back	Sends you back to the upper menu level.
17	Menu	Enters Menu mode and scrolls through the available menus.
18	Scan	Activates Scan mode.
19	Eco	Turn into eco mode to reduce toner consumption and paper usage (see "Eco options" on page 55).
20	Direct USB	Allows you to directly print files stored on a USB memory device when it is inserted into the USB port on the front of your machine.



Type C

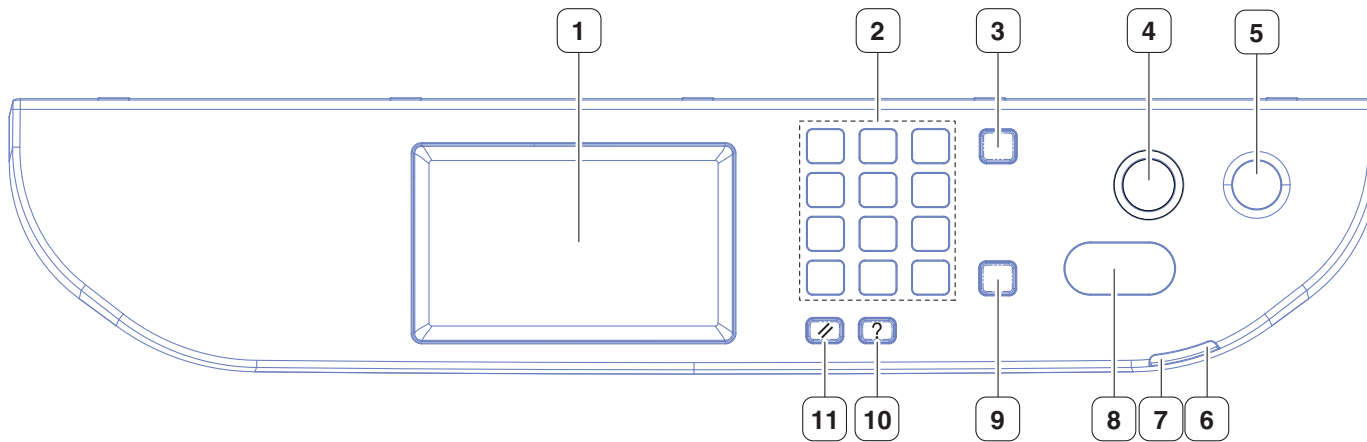

1	Display screen	Shows the current status and prompts during an operation.
2	Numeric keypad	Dials a number or enters alphanumeric characters.
3	Clear	Deletes characters in the edit area.
4	Stop	Stops an operations at any time.
5	Power	Turn the power on or off, or wake up the machine from the power save mode. If you need to turn the machine off, press this button for more than three seconds. You can also turn the power on, or wake up the machine from power save mode by pressing this button.
6	Wireless LED	Shows the current status of the wireless network connection (see "Understanding the status LED" on page 108).
7	Status	Shows the status of your machine (see "Understanding the status LED" on page 108).
8	Start	Starts a job.

9	On Hook Dial	When you press this button, you can hear a dial tone. Then enter a fax number. It is similar to making a call using speaker phone.
10	Help	Gives detailed information about this machine's menus or status.
11	Reset	Resets the current machine's setup.

Turning on the machine

- 1 Connect the machine to the electricity supply first.

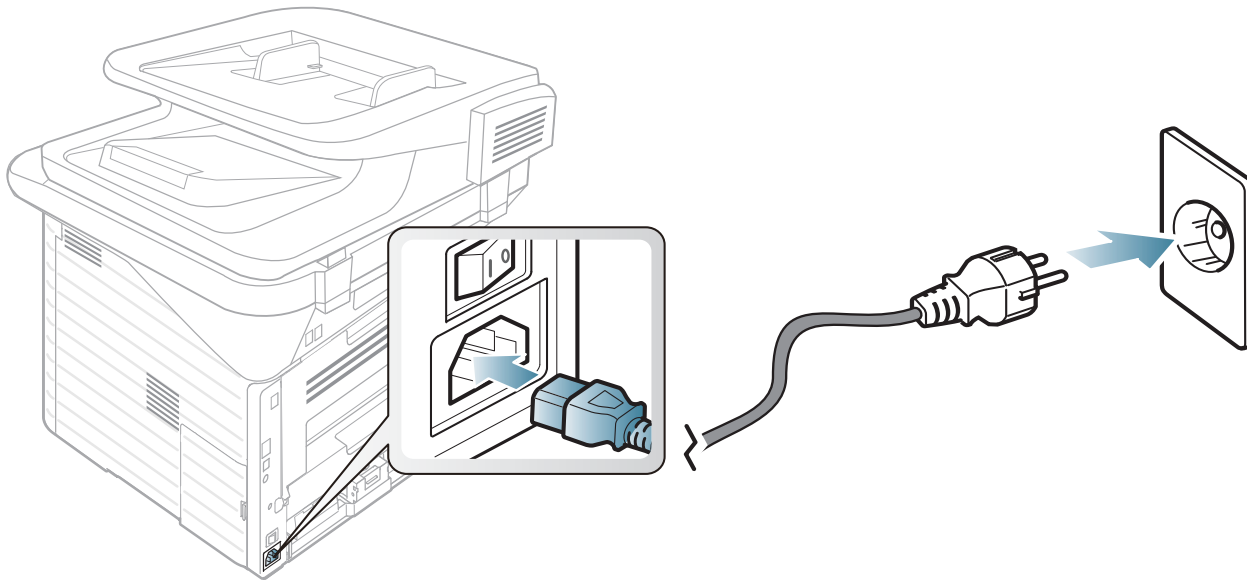

- 2 Turn the power switch on.

A locally connected machine is a machine directly attached to your computer using the cable. If your machine is attached to a network, skip the following steps below and go on to installing a network connected machine's driver (see Advanced Guide).



- If you are a Macintosh, Linux, or Unix OS user, refer to the Advanced guide.
- The installation window in this User's Guide may differ depending on the machine and interface in use.
- Selecting **Advanced Installation > Custom Installation** allows you to choose which programs to install.
- Only use a USB cable no longer than 3 meters (118 inches).



Windows

- 1 Make sure that the machine is connected to your computer and powered on.



If the "**Found New Hardware Wizard**" appears during the installation procedure, click **Cancel** to close the window.

- 2 Insert the supplied software CD into your CD-ROM drive. Click **Start > All programs > Accessories > Run**.

Type X:**Setup.exe** replacing "X" with the letter, which represents your CD-ROM drive and click **OK**.

- 3 Select **Install Now**.

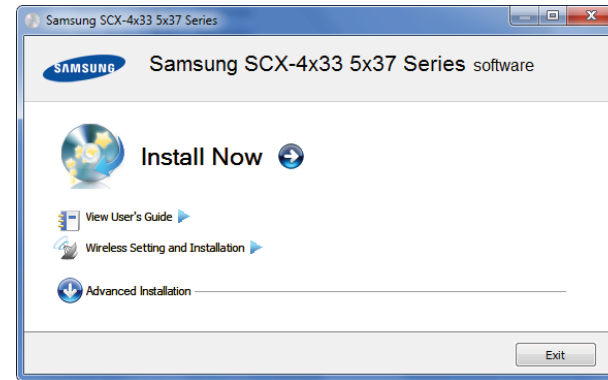

- 4 Read **License Agreement**, and select **I accept the terms of the License Agreement**. Then, click **Next**.
- 5 Follow the instructions in the installation window.

If the printer driver does not work properly, follow the steps below to reinstall the driver.



Windows

- 1 Make sure that the machine is connected to your computer and powered on.
- 2 From the **Start** menu, select **Programs** or **All Programs** > **Samsung Printers** > **your printer driver name** > **Uninstall**.
- 3 Follow the instructions in the installation window.
- 4 Insert the software CD into your CD-ROM drive and install the driver again (see "Installing the driver locally" on page 26).



2. Menu overview and basic setup

This chapter provides information about the overall menu structure and the basic setup options.

- **Menu overview** 29
- **Changing the display language** 34
- **Media and tray** 35
- **Basic printing** 51
- **Basic copying** 57
- **Basic scanning** 62
- **Basic faxing** 63
- **Using USB memory device** 68



SCX-4833FD, SCX-4833FR, SCX-5637FR

The control panel provides access to various menus to set up the machine or use the machine's functions.



- An asterisk (*) appears next to the currently selected menu.
- Some menus may not appear on the display depending on options or models. If so, it is not applicable to your machine.
- Some menu names may differ from your machine depending on its options or the models.

Accessing the menu

- 1 Select the Fax, Copy, or Scan button on the control panel depending on the feature to be used.
- 2 Select  (**Menu**) until the menu you want appears on the bottom line of the display and press **OK**.

- 3 For SCX-4833FD, press the left/right arrows until the needed menu item appears and press **OK**.
 - For SCX-4833FR / SCX-5637FR, press the up/down arrows until the needed menu item appears and press **OK**.
- 4 If the setting item has sub menus, repeat step 3.
- 5 For SCX-4833FD, press the left/right arrows to access the required value.
 - For SCX-4833FR / SCX-5637FR, press the up/down arrows to access the required value.
- 6 Press **OK** to save the selection.
- 7 Press  (**Stop/Clear**) to return to the ready mode.

SCX-4833FD

Items	Options
Fax Feature	Darkness Contrast Resolution Scan Size Multi Send Delay Send Priority Send Forward Secure Receive Add Page Cancel Job
Fax Setup	Sending Receiving Change Default Auto Report

Items	Options
Copy Feature	Scan Size Reduce/Enlarge Duplex Darkness Contrast Original Type Layout Adjust Bkgd. Margin Shift
Copy Setup	Change Default
Scan Feature	USB Feature E-mail Feature
Scan Setup	Change Default
Print Setup	Orientation Copies Resolution Darkness Darken Text Emulation

Items	Options
System Setup	Machine Setup Paper Setup Sound/Volume Report Maintenance Clear Setting Job Management
Network	TCP/IP (IPv4) TCP/IP (IPv6) Ethernet Speed 802.1x Clear Setting Network Conf.

SCX-4833FR /SCX-5637FR

Items	Options
Fax Feature	Darkness Contrast Resolution Scan Size Duplex Multi Send Delay Send Priority Send Forward Secure Receive Add Page Cancel Job
Fax Setup	Sending Receiving Change Default Auto Report

Items	Options
Copy Feature	Scan Size Reduce/Enlarge Duplex Darkness Contrast Original Type Layout Adjust Bkgd. Margin Shift Edge Erase
Copy Setup	Change Default
Scan Feature	USB Feature E-mail Feature FTP Feature SMB Feature
Scan Setup	Change Default Send Report

Items	Options
Print Setup	Orientation Copies Resolution Darkness Darken Text Emulation
System Setup	Machine Setup Paper Setup Sound/Volume Report Maintenance Clear Setting Job Manage. Image Overwrite
Network	TCP/IP (IPv4) TCP/IP (IPv6) Ethernet Speed 802.1x Clear Setting Network Configuration

Items	Options
Document Box	Doc Box Feature Shared Folder Feature Doc Box Setup Shared Folder Setup Doc Box Report
Custom	

Changing the display language

To change the language that is displayed on the control panel, follow these steps:



Accessing menus may differ from model to model (see "Accessing the menu" on page 29).

- 1 Select  (**Menu**) > **System Setup** > **Machine Setup** > **Language** on the control panel.



It may be necessary to press **OK** to navigate to lower-level menus for some models.

- 2 Select the language you want to display on the control panel.
- 3 Press **OK** to save the selection.

This chapter provides information on how to load print media into your machine.



- Using print media that does not meet these specifications may cause problems or require repairs. Such repairs are not covered by Samsung's warranty or service agreements.
- Make sure not to use the inkjet photo paper with this machine. It could cause damage to the machine.
- Using inflammable print media can cause a fire.
- Use designated print media (see "Print media specifications" on page 125).



The use of inflammable media or foreign materials left in the printer may lead to overheating of the unit and, in rare cases may cause a fire.



Tray overview

To change the size, you need to adjust the paper guides.

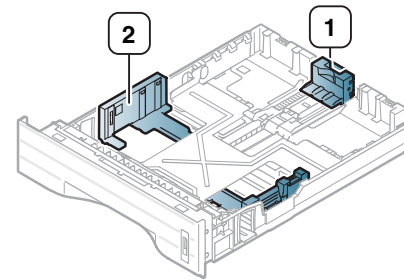

- 1 Paper length guide
- 2 Paper width guide

The duplex unit is preset to Letter/LGL or A4 size, depending on your country. To change the paper size, adjust the guide as shown below.



If you do not adjust the guide, it may cause paper registration, image skew, or jamming of the paper.

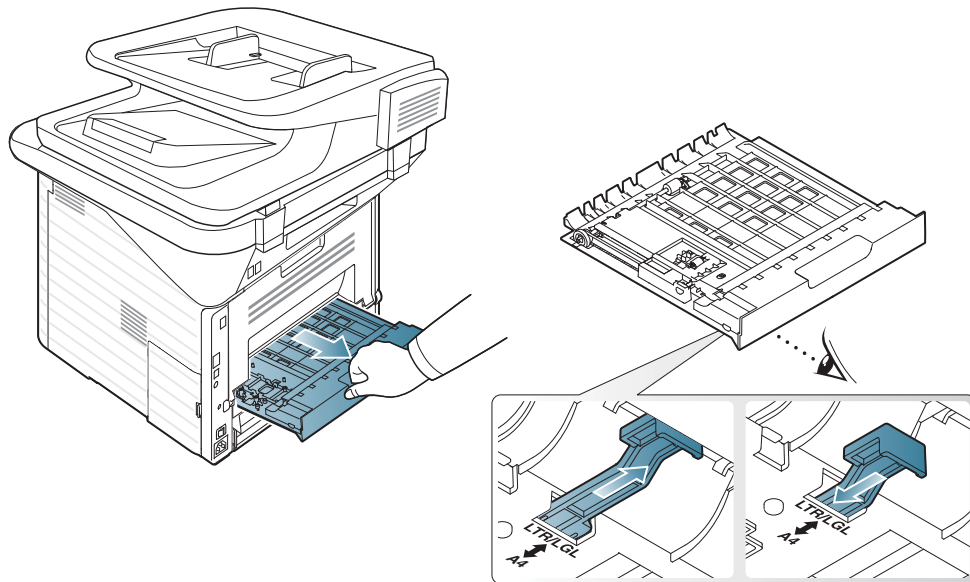

Paper quantity indicator shows the amount of paper in the tray.

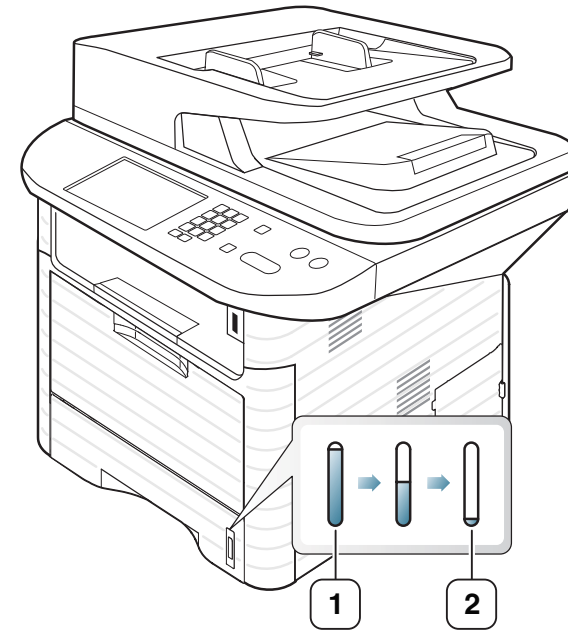

- 1 Full
- 2 Empty



Loading paper in the tray/ optional tray

- 1 Pull out the paper tray.
- 2 Flex or fan the edge of the paper stack to separate the pages before loading papers.

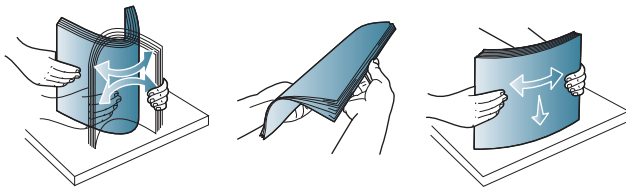

- 3 Place paper with the side you want to print on facing down.

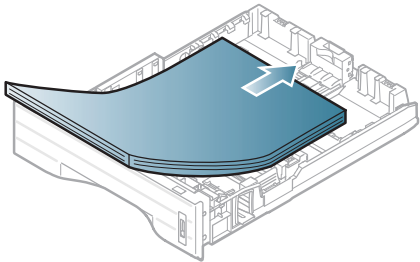

- 4 Slide the paper length guide until it lightly touches the end of the paper stack.

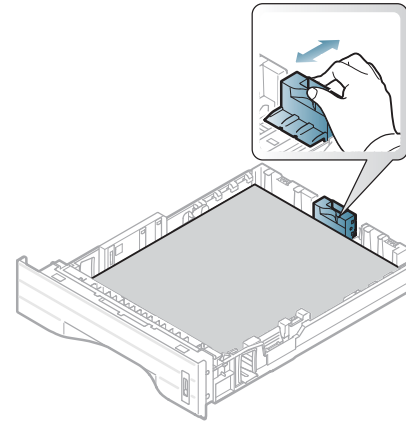

- 5 Squeeze the paper width guide and slide it to the edge of the paper stack without causing it to bend.

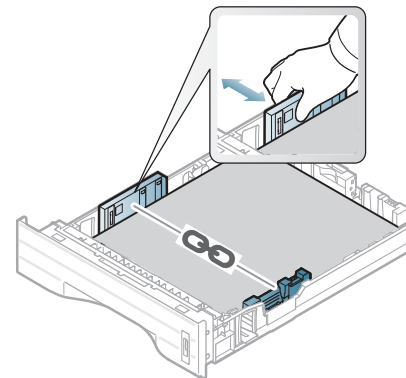



- Do not push the paper width guide too far causing the media to warp.
- If you do not adjust the paper width guide, it may cause paper jams.

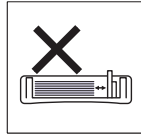
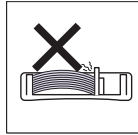
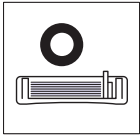

- Do not use a paper with a leading-edge curl, it may cause a paper jam or the paper can be wrinkled.

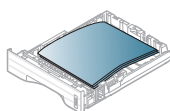
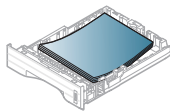
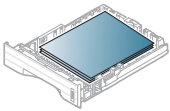

6 Insert the tray back into the machine.

7 Set the paper type and size for tray 1 (see "Setting the paper size and type" on page 46).



Loading in multi-purpose tray

The multi-purpose tray can hold special sizes and types of print material, such as postcards, note cards, and envelopes (see "Print media specifications" on page 125).



Tips on using the multi-purpose tray

- To prevent paper jams, do not add paper while printing when there is still paper in the multi-purpose tray.
- Print media should be loaded face up with the top edge going into the multi-purpose tray first and be placed in the center of the tray.
- To ensure printing quality and to prevent paper jams, only load the available paper (see "Print media specifications" on page 125).
- Flatten any curl on postcards, envelopes, and labels before loading them into the multi-purpose tray.
- When printing on special media, you must follow the loading guidelines (see "Printing on special media" on page 41).
- When papers overlap when printing using the multi-purpose tray, open tray 1 and remove the papers then try printing again.
- When paper does not feed well while printing, push the paper in manually until it starts feeding automatically.

- 1 Open the multi-purpose tray and unfold the multi-purpose tray extension, as shown.

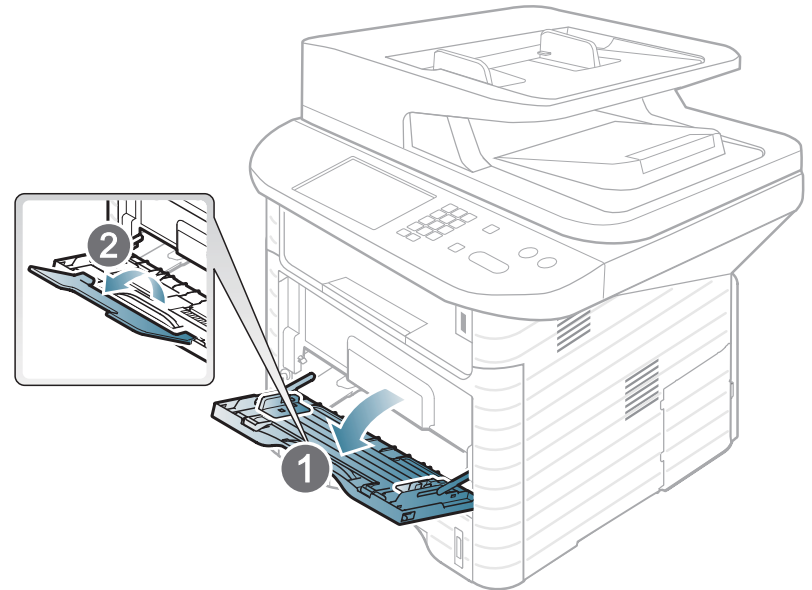

- 2** Adjust the multi-purpose tray paper width guides to the width of the paper.

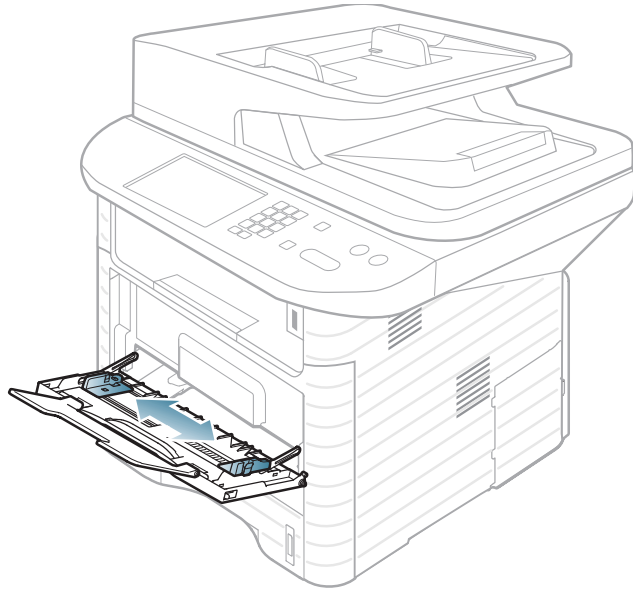

- 4** Load the paper. Squeeze the multi-purpose tray paper width guides and adjust them to the width of the paper.

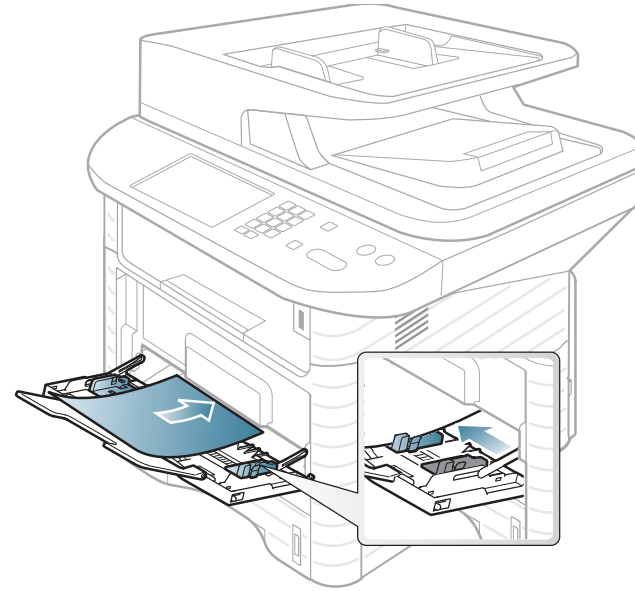

- 3** Flex or fan the edge of the paper stack to separate the pages before loading paper.

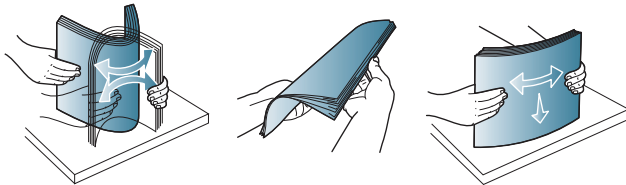

- 5** Set the paper type and size from the control panel (see "Setting the paper size and type" on page 46).



Printing on special media

The table below shows the special media usable in each tray.

The media types are shown in the **Printing Preferences**. Select the proper media type to get the highest printing quality.



- When using special media, we recommend you feed one sheet at a time (see "Print media specifications" on page 125).
- **Printing the special media (Face up)**
If special media are printed out with curl, wrinkles, crease, or black bold lines, open the rear cover and try printing again. Keep the rear cover opened during printing.

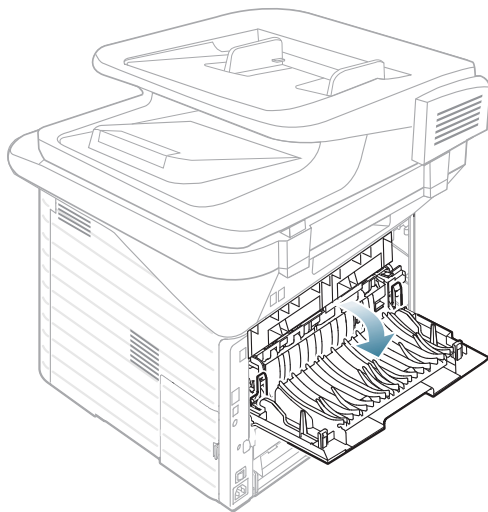

To see for paper weights for each sheet, refer to "Print media specifications" on page 125.

Types	Tray 1	Optional tray	Multi-purpose tray
Plain	●	●	●
Thick	●	●	●
Thicker			●
Thin	●	●	●
Bond	●	●	●
Color			●
CardStock	●	●	●
Labels			●
Transparency			●
Envelope			●
Preprinted			●
Cotton			●
Recycled	●	●	●
Archive	●	●	●

(●: Included, Blank: Not available)

Envelope

Printing successfully on envelopes depends upon the quality of the envelopes.

To print an envelope, place it as shown in the following figure.

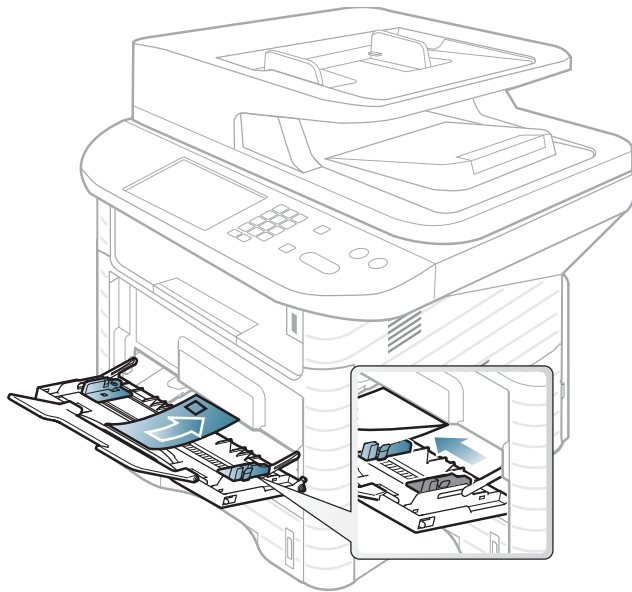

If envelopes are printed out with wrinkles, crease, or black bold lines, open the rear cover and pull down the pressure lever on the right side about 90 degrees and try printing again. Keep the rear cover opened during printing.

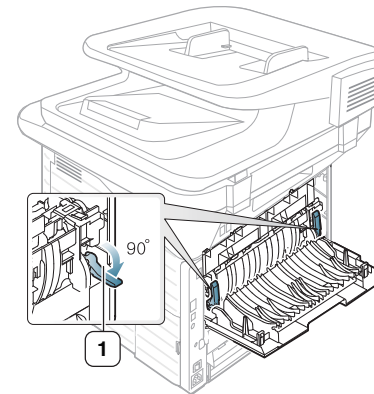

1 Pressure lever

- When selecting envelopes, consider the following factors:
 - **Weight:** should not exceed 90 g/m² otherwise; jams may occur.
 - **Construction:** should lie flat with less than 6 mm curl and should not contain air.
 - **Condition:** should not be wrinkled, nicked, nor damaged.
 - **Temperature:** should resist the heat and pressure of the machine during operation.
- Use only well-constructed envelopes with sharp and well-creased folds.
- Do not use stamped envelopes.
- Do not use envelopes with clasps, snaps, windows, coated lining, self-adhesive seals, or other synthetic materials.
- Do not use damaged or poorly made envelopes.

- Be sure the seam at both ends of the envelope extends all the way to the corner of the envelope.

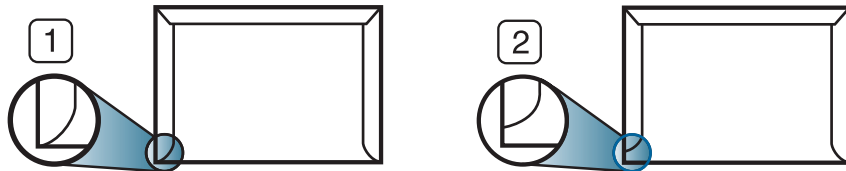

- 1 Acceptable
- 2 Unacceptable

- Envelopes with a peel-off adhesive strip or with more than one flap that folds over to seal must use adhesives compatible with the machine's fusing temperature for 0.1 second (about 170°C (338 °F)). The extra flaps and strips might cause wrinkling, creasing, or jams, and may even damage the fuser.
- For the best print quality, position margins no closer than 15 mm from the edges of the envelope.
- Avoid printing over the area where the envelope's seams meet.

Transparency

To avoid damaging the machine, use only transparencies designed for use in laser printers.

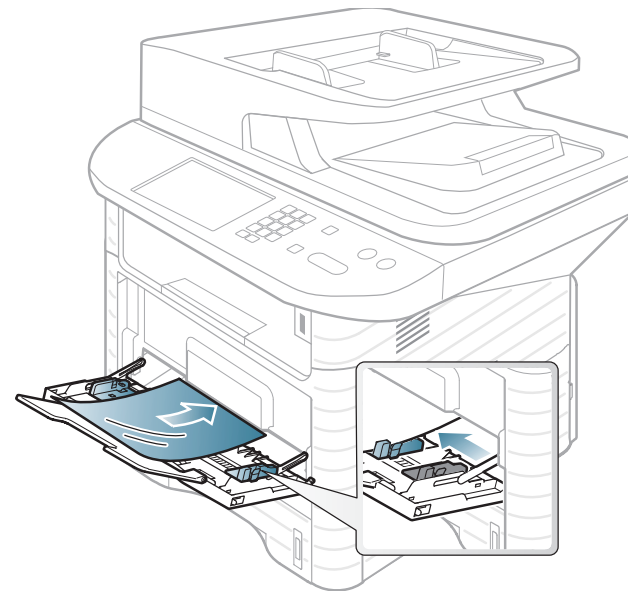

- Must withstand the machine's fusing temperature.
- Place them on a flat surface after removing them from the machine.
- Do not leave unused transparencies in the paper tray for long. Dust and dirt may accumulate on them, resulting in spotty printing.
- To avoid smudging caused by fingerprints, handle them carefully.

- To avoid fading, do not expose printed transparencies to prolonged sunlight.
- Ensure that transparencies are not wrinkled, curled, or have any torn edges.
- Do not use transparencies that separate from the backing sheet.
- To prevent transparencies from sticking to each other, do not let the printed sheets stack up as they are being printed out.
- Recommended media: Transparency for a color laser printer by Xerox, such as 3R 91331(A4), 3R 2780(Letter)

Labels

To avoid damaging the machine, use only labels designed for use in laser printers.

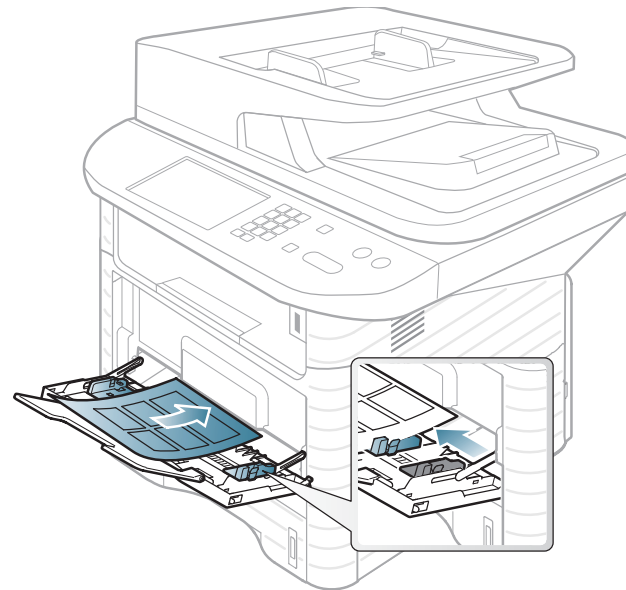

- When selecting labels, consider the following factors:
 - **Adhesives:** Should be stable at your machine's fusing temperature. Check your machine's specifications to view the fusing temperature (about 170°C (338°F)).
 - **Arrangement:** Only use labels with no exposed backing between them. Labels can peel off sheets that have spaces between the labels, causing serious jams.
 - **Curl:** Must lie flat with no more than 13 mm of curl in any direction.

- **Condition:** Do not use labels with wrinkles, bubbles, or other indications of separation.
- Make sure that there is no exposed adhesive material between labels. Exposed areas can cause labels to peel off during printing, which can cause paper jams. Exposed adhesive can also cause damage to machine components.
- Do not run a sheet of labels through the machine more than once. The adhesive backing is designed for only a single pass through the machine.
- Do not use labels that are separating from the backing sheet or are wrinkled, bubbled, or otherwise damaged.

Card stock/ Custom-sized paper

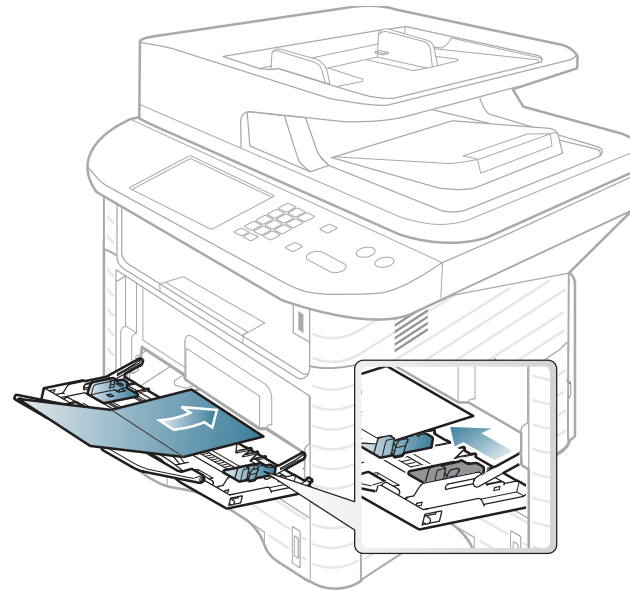

- In the software application, set margins at least 6.4 mm (0.25 inches) away from the edges of the material.