

\* Some of the contents of this manual may differ from your phone,  
depending on the software installed or your service provider.



World Wide Web  
<http://www.samsungmobile.com>

Printed in Korea  
Code No.:GH68-XXXXXA  
English. 05/2004. Rev 1.0

**SAMSUNG**

**GPRS TELEPHONE  
SGH-X910**

**DRAFT**



# Contents

<b>Important safety precautions .....</b>	<b>7</b>
<b>Unpacking .....</b>	<b>9</b>
<b>Your phone .....</b>	<b>10</b>
Phone layout.....	10
Display.....	13
Service light .....	16
Camera.....	16
<b>Getting started.....</b>	<b>17</b>
Installing the SIM card .....	17
Charging the battery .....	19
Using a memory card .....	21
Switching on or off the phone.....	22
Using the Keypad Lock feature .....	23
<b>Call functions .....</b>	<b>24</b>
Making a call.....	24
Adjusting the volume .....	29
Answering a call .....	30
Viewing missed calls .....	31
Quickly switching to Silent mode .....	33
<b>Selecting functions and options .....</b>	<b>34</b>
Using the soft keys .....	34
Selecting options.....	35
<b>Entering text.....</b>	<b>36</b>
Changing the text input mode .....	37
Using T9 mode.....	38
Using Alphabet mode .....	40
Using Number mode .....	41
Using Symbol mode.....	41
<b>Options during a call .....</b>	<b>42</b>
Putting a call on hold .....	42
Using the menu functions .....	43
Switching off the microphone (Mute).....	44
Muting or sending key tones .....	45
Sending a sequence of DTMF tones.....	45
Searching for a number in Phonebook .....	46



## Contents

Call waiting.....	47
Making a multi-party call .....	47
<b>Using the menus .....</b>	<b>50</b>
Accessing a menu function by scrolling .....	50
Using shortcuts .....	51
List of menu functions.....	52
<b>Call records.....</b>	<b>57</b>
Missed calls ( <i>Menu 1.1</i> ).....	57
Received calls ( <i>Menu 1.2</i> ).....	58
Dialled calls ( <i>Menu 1.3</i> ).....	58
Delete all ( <i>Menu 1.4</i> ) .....	59
Call time ( <i>Menu 1.5</i> ).....	60
Call cost ( <i>Menu 1.6</i> ) .....	61
<b>Phonebook.....</b>	<b>62</b>
Search ( <i>Menu 2.1</i> ) .....	62
New entry ( <i>Menu 2.2</i> ).....	64
Group search ( <i>Menu 2.3</i> ).....	66
Group edit ( <i>Menu 2.4</i> ) .....	67
Speed dial ( <i>Menu 2.5</i> ).....	68
Delete all ( <i>Menu 2.6</i> ) .....	69
Memory status ( <i>Menu 2.7</i> ).....	70
Own number ( <i>Menu 2.8</i> ) .....	70
SDN (Service Dialling Numbers) ( <i>Menu 2.9</i> ).....	71
<b>Applications .....</b>	<b>72</b>
MP3 player ( <i>Menu 3.1</i> ).....	72
Voice memo ( <i>Menu 3.2</i> ) .....	75
SIM AT menu ( <i>Menu 3.3</i> ) .....	77
<b>Browser .....</b>	<b>78</b>
Home ( <i>Menu 4.1</i> ) .....	78
Bookmarks ( <i>Menu 4.2</i> ).....	82
http:// ( <i>Menu 4.3</i> ).....	82
WAP profile ( <i>Menu 4.4</i> ) .....	83
Clear cache ( <i>Menu 4.5</i> ) .....	84
<b>Messages .....</b>	<b>85</b>
Text messages ( <i>Menu 5.1</i> ) .....	85
Multimedia messages ( <i>Menu 5.2</i> ) .....	94
Push message ( <i>Menu 5.3</i> ) .....	107
Voice mail ( <i>Menu 5.4</i> ).....	108
Broadcast messages ( <i>Menu 5.5</i> ).....	108



<b>Funbox.....</b>	<b>110</b>
Games (Menu 6.1) .....	110
Sounds (Menu 6.2).....	117
Images (Menu 6.3).....	117
Videos (Menu 6.4).....	118
Delete all (Menu 6.5) .....	118
Memory status (Menu 6.6).....	119
<b>Organiser .....</b>	<b>120</b>
Alarm (Menu 7.1).....	120
Calendar (Menu 7.2).....	122
To do list (Menu 7.3) .....	124
Calculator (Menu 7.4) .....	126
Currency converter (Menu 7.5) .....	127
<b>Camera .....</b>	<b>128</b>
Taking a photo.....	128
Photos (Menu 8.1).....	132
Videos (Menu 8.2).....	133
My album (Menu 8.3).....	136
Delete all (Menu 8.4) .....	139
Memory status (Menu 8.5).....	139
Select memory location (Menu 8.6) .....	140
<b>Settings .....</b>	<b>141</b>
Time & Date (Menu 9.1).....	141
Phone settings (Menu 9.2).....	143
Display settings (Menu 9.3) .....	148
Sound settings (Menu 9.4) .....	151
Network services (Menu 9.5) .....	155
Security (Menu 9.6).....	162
Reset settings (Menu 9.7) .....	166
<b>Solving problems .....</b>	<b>167</b>
<b>Access codes.....</b>	<b>170</b>
Phone password .....	170
PIN.....	171
PUK.....	171
PIN2 .....	172
PUK2 .....	172
Barring password .....	173

## Contents

<b>Health and safety information.....</b>	<b>174</b>
<b>Glossary .....</b>	<b>187</b>
<b>Index .....</b>	<b>193</b>
<b>Quick reference card .....</b>	<b>199</b>



# Important safety precautions

Read these guidelines before using your wireless phone. Failure to comply with them may be dangerous or illegal.

## **Road safety at all times**

Do not use a hand-held phone while driving; park the vehicle first.

## **Switching off when refuelling**

Do not use the phone at a refuelling point (service station) or near fuels or chemicals.

## **Switching off in an aircraft**

Wireless phones can cause interference. Using them in an aircraft is both illegal and dangerous.

## **Switching off in hospitals**

Switch your phone off near medical equipment. Follow any regulations or rules in force.

## **Interference**

All wireless phones may be subject to interference, which could affect their performance.

## **Special regulations**

Meet any special regulations in force in any area and always switch off your phone whenever it is forbidden to use it, or when it may cause interference or danger (in a hospital for example).





## **Important safety precautions**

### **Sensible use**

Use only in the normal position (held to the ear). Avoid unnecessary contact with the antenna when the phone is switched on.

### **Emergency call**

Ensure the phone is switched on and in service. Key in the emergency number for your present location, then press the  key. You must deactivate any unnecessary features in use before you can make an emergency call. Give all the necessary information as accurately as possible. Do not end the call until given permission to do so.

### **Water resistance**

Your phone is not water-resistant. Keep it dry.

### **Accessories and batteries**

Use only Samsung-approved accessories and batteries. Use of any unauthorised accessories could damage your phone and may be dangerous.

### **Qualified service**

Only qualified service personnel may repair your phone.

For more detailed safety information, see "Health and safety information" on page 174.

#### **CAUTION**

RISK OF EXPLOSION IF A BATTERY IS REPLACED  
BY AN INCORRECT TYPE  
DISPOSE OF USED BATTERIES ACCORDING TO  
THE INSTRUCTIONS

# Unpacking

Your package contains the following items:

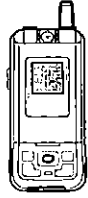

Handset

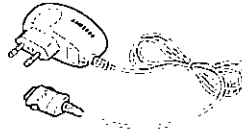

Travel adapter



Battery



User's Manual

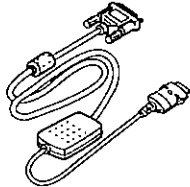

PC link cable

**Note:** The items supplied with your phone may be different, depending upon your country or service provider.

You can obtain the following accessories for your phone from your local Samsung dealer:

- Standard batteries
- Simple hands-free kit
- Travel charger/adapter
- Hand strap
- Straight headset
- Battery charger
- Data kit



# Your phone

## Phone layout

---

The following illustrations show the main elements of your phone:

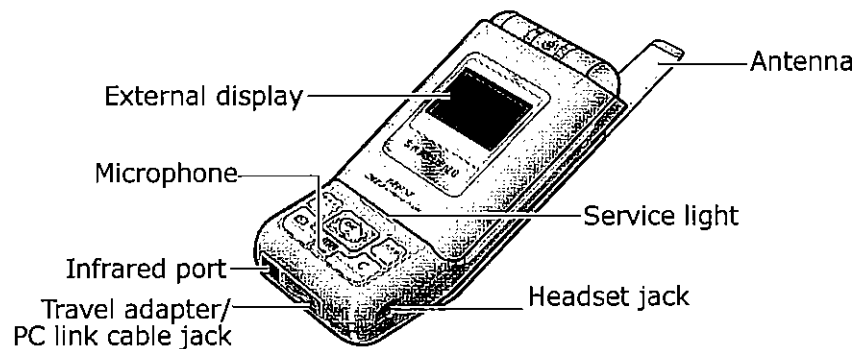
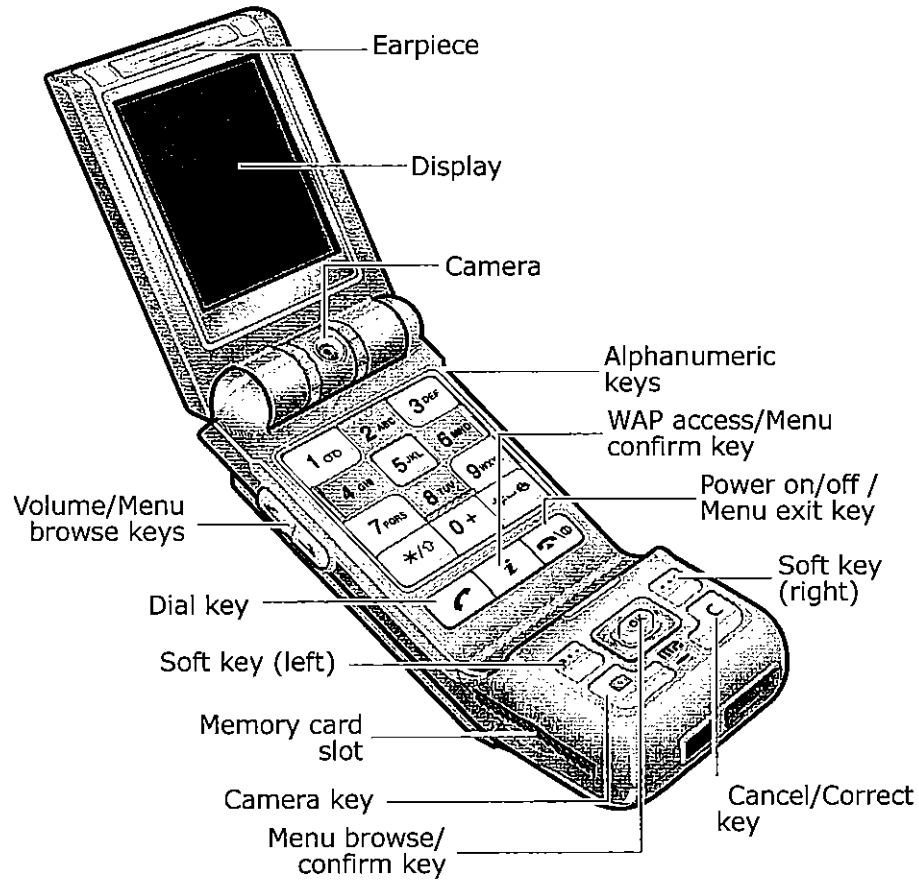

### Key(s) Description

 Performs the functions indicated by the text above them, on the bottom line of the display.  
(soft keys)



Performs the function assigned to the left soft key when pressed.

In Idle mode, allows you to access your favourite menu options directly, depending on which direction you press it. For further details about shortcuts, see page 147.

In Menu mode, scrolls through the menu options when pressed up (toward the top of the phone) or down (toward the bottom of the phone).

In a text input field, moves the cursor when pressed to each direction.



In Idle mode, allows you to access the **Camera** menu. Turns on the camera when held down.

In Capture mode, takes a photo.



Deletes characters from the display.

In Menu mode, returns you to the previous menu level.











Makes or answers a call.

In Idle mode, retrieves the list of most recent calls you have dialled, received, or missed.



## Your phone

Key(s)	Description (continued)
	<p>In Idle mode, launches the WAP (Wireless Application Protocol) browser.</p> <p>In Menu mode, performs the same as the left soft key.</p>
	<p>Ends a call. Also switches the phone on and off when held down.</p> <p>In Menu mode, cancels your input and returns the phone to Idle mode.</p>
	<p>In Idle mode, accesses your voice mail when held down.</p>
  	<p>Enters numbers, letters, and some special characters.</p>
 	<p>Enters special characters.</p> <p>Performs various functions.</p>
	<p>(on the left side of the phone)</p> <p>During a call, adjust the earpiece volume.</p> <p>In Idle mode, with the phone open, adjust the keypad tone volume. With the phone closed, turn the external display on when held down.</p> <p>In Menu mode, scroll through menu options.</p>

## Display

---

### Display layout



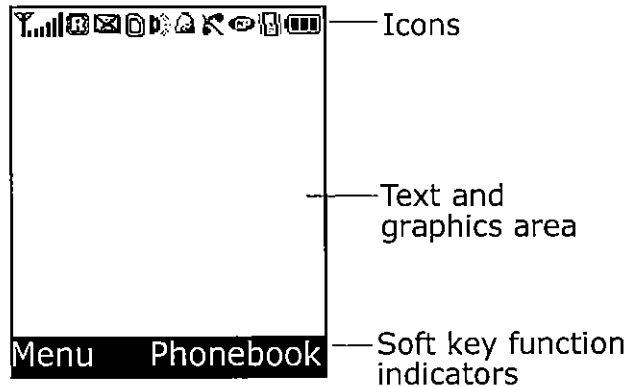







The display has three areas:



Area	Description
First line	Displays various icons. See page 14.
Middle lines	Displays messages, instructions, and any information that you enter, such as the number you are dialling.
Last line	Shows the current functions assigned to the two soft keys.

## Your phone

### Icons

Icon	Description
	Shows the received signal strength. The greater the number of bars, the stronger the signal.
	Appears when you are out of your home area and have logged onto a different network; for example, when travelling in other countries.
	Appears when a new text message has been received.
	Appears when a new voice mail message has been received.
	Appears when a new multimedia message has been received.
	Appears when a new text message and a new multimedia message has been received.
	Appears when a memory card is inserted into the phone.
	Appears when the infrared port is active. For details, see page 143.
	Appears when you set an alarm to ring at a specified time.
	Appears when a call is in progress.
	Appears when you are out of your service area. When it displays, you cannot make or receive a call.

### Icon Description (continued)



Appears when you are connected to the GPRS network.



Appears when the Call Diverting feature is activated.



Appears when Silent mode is active or when you set the phone to vibrate when you receive a call. For further details, see page 33 and page 151 respectively.



Appears when Mute mode is active.



Shows the level of your battery. The more bars you see, the more power you have remaining.

## Backlight

The backlight illuminates the display and the keypad. When you press any key or open the phone, the backlight comes on. It goes off when no keys are pressed within a given period of time, depending on the setting in the **Back light** menu (**Menu 9.3.4**). The display turns off after one minute to conserve battery power.

To specify the length of time the backlight is active, set the **Back light** menu. See page 150 for further details.



## Your phone

### External display

Your phone has an external display on the front. It indicates when you have an incoming call or a message. It also alerts you at a specified time when you have set an alarm. The backlight turns on and the corresponding icon appears on the external display.

You can select the image to be displayed in the **Sub LCD** menu (**Menu 9.3.2**). See page 149 for further details.

To turn the display on when the phone is closed, press and hold either of the Volume keys on the left side of the phone. You can also press and hold the Camera key on the front of your phone to take a photo using the external display.

### Service light

---

The service light flashes when services are available on the phone.

To activate or deactivate the service light, use the **Service light** menu (**Menu 9.3.5**). See page 150 for further details.

### Camera

---

The camera module on the top of your phone allows you to take a photo and record a video while on the move.

For further details about the Camera feature, see page 128.



# Getting started

## Installing the SIM card

---

When you subscribe to a cellular network, you are provided with a plug-in SIM card loaded with your subscription details, such as your PIN, any optional services available, and so on.

**Important!** The plug-in SIM card and its contacts can be easily damaged by scratches or bending, so be careful when handling, inserting or removing the card.

Keep all SIM cards out of the reach of small children.

1. If necessary, switch off the phone by holding down the  key until the power-off image displays.
2. Remove the battery. To do so:
  - ① Pull the battery lock toward the bottom of the phone and hold it in that position.
  - ② Lift away the battery, as shown.

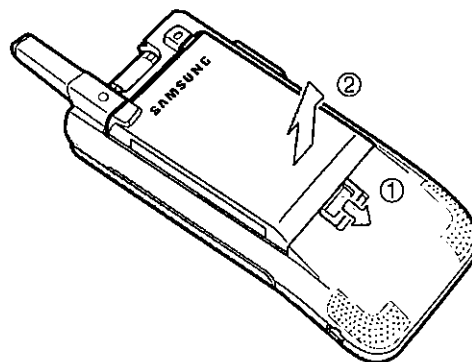

## Getting started

- Slide the SIM card into the SIM card socket, as shown, so that the card locks into position.

Make sure the gold coloured contacts of the card face into the phone.

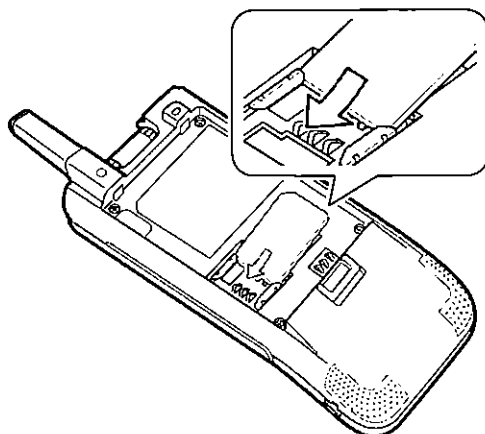

**Note:** When you need to remove the SIM card, slide it upward, as shown, and take it out of the socket.

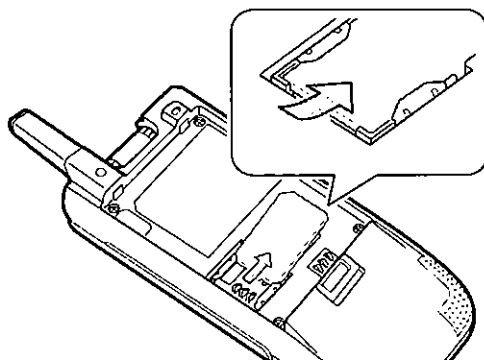

- Replace the battery so that the tabs on the top align with the slots at the top of the phone.

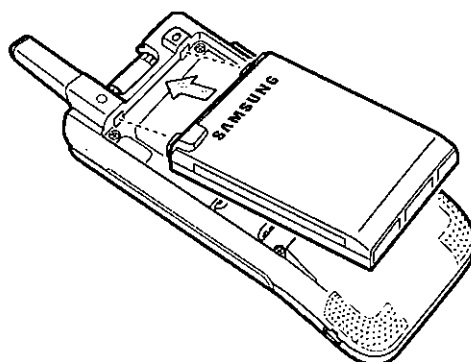

5. Press the battery down until it clicks into place. Make sure that the battery is properly installed before switching the power on.

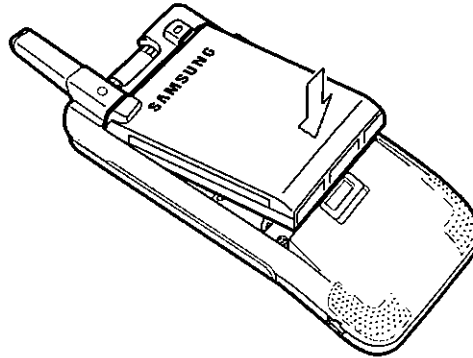

## Charging the battery

---

Your phone is powered by a rechargeable Li-ion battery. A travel adapter comes with your phone for charging the battery. Use only approved batteries and chargers. Ask your local Samsung dealer for further details.

The travel adapter allows you to use the phone while the battery is charging, but this causes the phone to charge more slowly.

**Note:** You must fully charge the battery before using your phone for the first time. A discharged battery recharges fully in approximately 200 minutes.

1. With the battery in position on the phone, plug the connector of the travel adapter into the jack at the bottom of the phone.

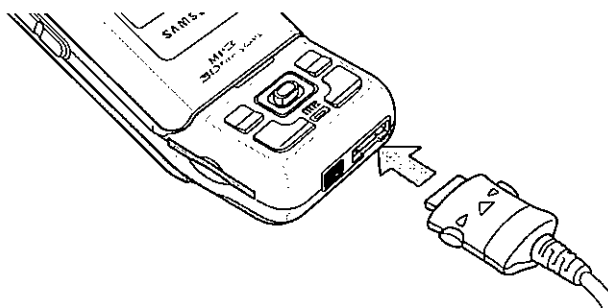

## Getting started

2. Plug the adapter into a standard AC wall outlet.
3. When charging is finished, unplug the adapter from the power outlet and disconnect it from the phone by pressing the buttons on both sides of the connector and pulling the connector out.

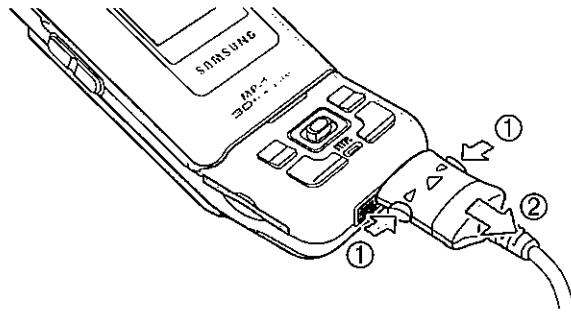

**Note:** You must unplug the adapter before removing the battery from the phone during charging; otherwise, the phone could be damaged.

## Low battery indicator

When the battery is weak and only a few minutes of talk time remain, a warning tone sounds and the "Warning Low battery" message repeats at regular intervals on the display. When this happens, your phone turns off the backlight to conserve the remaining battery power.

If the battery level becomes too low, the phone will automatically turn off.

## Using a memory card

---

You can use an optional memory card to enlarge the memory capacity of the phone.

You can save images, sounds, videos, and MP3 files downloaded from the wireless web on the memory card, or copy media files from the computer to the phone using the memory card.

To save the files from your computer to the memory card, use a memory card reader/writer. You can purchase a memory card and a memory card reader/writer from certain electronics retailers.

### Notes:

- When you insert a memory card via a card reader/writer into the USB port of your computer, the SAMSUNG folder automatically appears in the appropriate directory. To enable the phone to read files, you need to copy those files into the SAMSUNG folder.
- You can delete all of the files stored in the memory card only using the FAT format.

## Installing the memory card

Slide it into the slot located on the left side of the phone, with the label side face up. Press the card until it clicks into place.

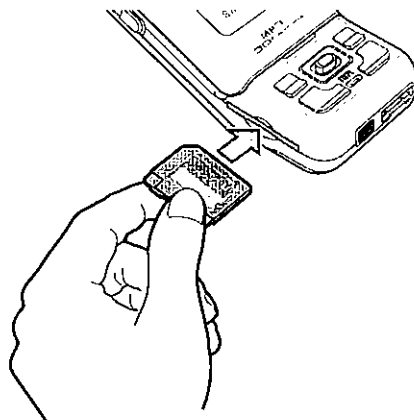

## Getting started

### Removing the memory card

Press and release it so that it is disengaged from the slot. Then slide the card out.

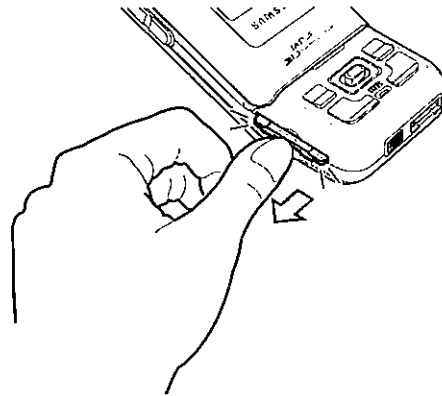

### Switching on or off the phone

---

1. Open the phone.
2. Press and hold the  key until the phone switches on.
3. If the phone asks you to enter a password, enter the password and press the **OK** soft key. The password is preset to "00000000" at the factory. For further details, see page 170.
4. If the phone asks for a PIN, enter the PIN and press the **OK** soft key. For further details, see page 171.

The phone searches for your network and, after finding it, the idle screen appears on the display. Now, you can make or receive calls.

**Note:** The display language is preset to English at the factory. To change the language, use the **Language** menu (**Menu 9.2.1**). For further details, see page 143.

5. When you wish to switch the phone off, press and hold the  key until the power-off image displays.

## Using the Keypad Lock feature

When you close the phone, it automatically locks the keys on the front to keep them from being pressed accidentally.

To unlock the keys, press and hold the left soft key. "Key unlock" appears and the keys are activated. Now you can use the camera by pressing and holding the Camera key (  ) and MP3 player by pressing and holding the **OK** key down. For further details, see page 132 and page 73, respectively.

To lock the keys manually, press and hold the left key until "Key lock" appears.





# Call functions

## Making a call

---

When the idle screen displays, enter the area code and phone number, then press the  key.

**Note:** When you activate the **Auto redial** option in the **Extra settings** menu (**Menu 9.2.5**), the phone will automatically redial up to ten times if the person does not answer the call or is already on the phone. See page 147 for further details.

## Making an international call

1. Press and hold the **0** key.  
The **+** character appears.
2. Enter the country code, area code and phone number and press the  key.

## Correcting the number

To clear	Press the
the last digit displayed	<b>C</b> key.
any other digit in the number	<b>OK</b> key to the left or right until the cursor is immediately to the right of the digit to be cleared. Press the <b>C</b> key. You can also insert a missing digit.
the whole display	<b>C</b> key and hold it for more than one second.



## Ending a call

When you want to end your call, briefly press the  key or close the phone.

## Redialling the last number

The phone stores the numbers of the calls you've dialled, received, or missed, if the call recipient or caller is identified. See "Call records" on page 57 for further details.

To recall any of these numbers:

1. If you have typed characters on the display, press the  key to return to Idle mode.
2. Press the  key to display a list of the most recent numbers used in the order you dialled or received them.
3. Press the **OK** key up or down to scroll through the numbers until the number you want highlights.

4. <b>To</b>	<b>Press the</b>
dial the number	 key.
edit the number	<b>Options</b> soft key and select <b>Edit</b> . Change the number, referring to "Correcting the number" on page 24.
delete the number	<b>Options</b> soft key and select <b>Delete</b> .
delete all of the numbers on the Call log list	<b>Options</b> soft key and select <b>Delete all</b> . For details, see page 59.

## Call functions

### Making a call from Phonebook

You can store the phone numbers that you use regularly on the SIM card or the phone's memory. These entries are collectively called Phonebook.

once you have stored a number in Phonebook, you can dial it by pressing a few keys. You can also assign your most frequently-used numbers to number keys using the Speed Dial feature.



For further details about the Phonebook feature, see page 113.

### Storing a Number in Idle mode

As soon as you start to enter a number, **Save** appears above the left soft key to allow you to store the number in Phonebook.

1. Enter the number you want to store.

**Note:** If you make a mistake while entering a number, correct it using the **C** key. For further details, see page 24.

2. When you are sure that it is correct, press the **Save** soft key.
3. Select an icon to identify the category in which the number is to be stored. Three categories are available:
  -  : Mobile phone number
  -  : Office number
  -  : Home number

To select the category, press the **OK** key to the left or right and press the **Select** soft key.

4. Select a memory location, either **SIM** or **Phone**, by pressing the **OK** key up or down and press the **Select** soft key.

**Note:** When you change phones, any numbers stored in your SIM card memory are automatically available with the new phone, whereas any numbers stored in the phone's memory will need to be reentered.

5. Enter a name and press the **OK** soft key.

For further details about how to enter characters, see page 36.

6. If you do not want to save the number and name in the suggested location, press the **C** key to clear the location number and enter another location by pressing the number keys.

7. Press the **OK** soft key to store the name and number.

After storing, the phone displays the Phonebook name and number you just created.

8. <b>To</b>	<b>Press the</b>
use the entry options	<b>Options</b> soft key. For further details, see page 63.
return to the idle screen	 /⓪ key.

## Call functions

### Dialling a Number from Phonebook

Once you have stored phone numbers in Phonebook, you can dial easily and quickly by using the location numbers that were assigned to them in Phonebook.

**Note:** If you can't remember a location number, you must go into the **Search** menu to search for a number by name. For details, see page 62.

To dial a number from the SIM card:

1. In Idle mode, enter the location number for the phone number you want to dial and press the **#** key.

The list of entries on the SIM card appears.

2. You can press the **OK** key up or down to find other numbers on the list.
3. Press the **Dial** soft key or the  key when you have selected the number you want.

To dial a number from the phone's memory:

1. In Idle mode, press and hold the **0** key.
2. Enter the location number for the phone number you want to dial and press the **#** key.

The list of entries in the phone's memory appears.

3. You can press the **OK** key up or down to find other numbers on the list.
4. Press the **Dial** soft key or the  key when you have selected the number you want.

## Adjusting the volume

---

During a call, if you want to adjust the earpiece volume, use the Volume keys on the left side of the phone.

Press the ↑ key to increase the volume level and the ↓ key to decrease the level.

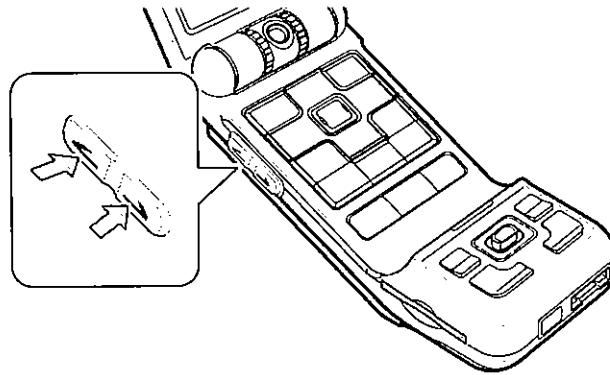

In Idle mode, you can also adjust the keypad tone volume using these keys.

## Answering a call

---

When somebody calls you, the phone rings and displays the incoming call image.

The caller's phone number or name, if stored in Phonebook, displays.

1. If necessary, open the phone. Press the  key or the **Accept** soft key to answer the incoming call.

When the **Anykey answer** option in the **Extra settings** menu (**Menu 9.2.5**) is activated, you can press any key to answer a call except for the /⓪ key and the **Reject** soft key. See page 148.

When the **Active folder** option in the **Extra settings** menu is activated, you can answer the call simply by opening the phone. See page 148.

**Note:** To reject the call, press and hold one of the Volume keys before opening the phone, or press the **Reject** soft key or /⓪ key.

2. End the call by closing the phone or pressing the /⓪ key.

**Note:** You can answer a call while using Phonebook or menu features. After ending the call, the display returns to the function screen you were using.

## Viewing missed calls

---

When you are unable to answer a call for any reason, you can find out who called you so that you can call the person back.

The number of calls you have missed displays on the idle screen immediately after a call is missed.

To view a missed call immediately:

1. If the phone is closed, open it.
2. Press the **View** soft key.

The number for the most recent missed call displays, if available.

3. <b>To</b>	<b>Press the</b>
scroll through the missed calls	<b>OK</b> key up or down.
call the number displayed	☎ key.
edit or delete a missed call number	<b>Select</b> soft key. See below.

### Editing a missed call number

**Note:** When the number for the missed call is not available, the **Edit** option does not display.

1. Press the **Options** soft key.
2. Press the **OK** key up or down to highlight the **Edit** option.
3. Press the **Select** soft key.



## Call functions

4. Change the number.

5. <b>To</b>	<b>Press the</b>
call the number	 key.
store the number	<b>Save</b> soft key and enter a name and location. For further details, see page 26.

## Deleting a missed call

1. Press the **Options** soft key.
2. If necessary, press the **OK** key up or down to highlight the **Delete** option.
3. Press the **Select** soft key.

You can press the  key at any time to exit the Missed Call feature.

**Note:** You can access the Missed Call feature at any time by selecting the **Missed Calls** menu (**Menu 1.1**). For further details, see page 57.

## Quickly switching to Silent mode

Silent mode is convenient when you wish to stop the phone from ringing, in a theatre for example.

In Idle mode, press and hold the # key until the "Silent Mode" message and the Vibration icon () display.

In Silent mode, your phone changes the sound settings as follows:



Tone	New Setting
Alert type	Vibration
Keypad tone	Off
Text/Multimedia message tone	Light + Vibration
Broadcast message tone	Light only
Folder tone	Off
Power off tone	Vibration
Extra tones	Off

To exit and reactivate the previous sound settings, press and hold the # key again until "Exit Silent Mode" appears. The Vibration icon no longer displays.

### Notes:

- When you turn off the phone, Silent mode is automatically deactivated.
- Activating Silent mode will not turn off the camera shutter sound.

# Selecting functions and options

Your phone offers a set of functions that allow you to customise it. These functions are arranged in menus and sub-menus, accessed using the two soft keys,  and . Each menu and sub-menu allows you to view and alter the settings of a particular function.

## Using the soft keys

---

The roles of the soft keys vary depending on the function you are currently using; the labels on the bottom line of the display just above each key indicate their current role.

Example:

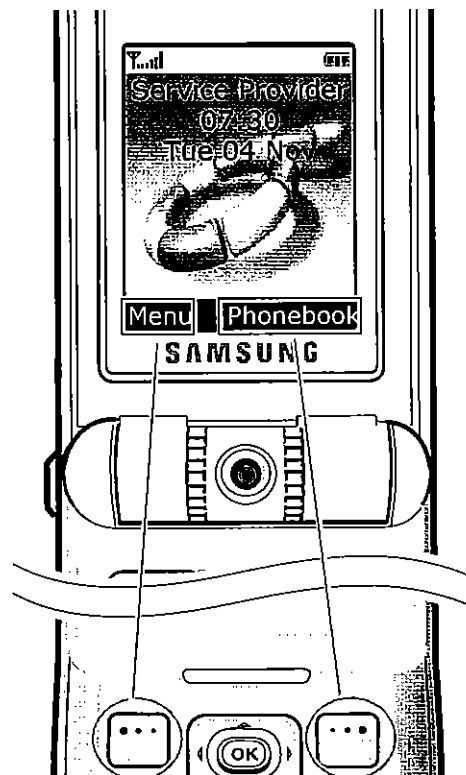

Press the left soft key to access Menu mode.

Press the right soft key to access the **Phonebook** menu.

## Selecting options

To view the various functions and options available and to select the one you want:

1. Press the appropriate soft key.

2. <b>To</b>	<b>Press the</b>
select the: <ul style="list-style-type: none"> <li>• function displayed</li> <li>• option highlighted</li> </ul>	<b>Select</b> soft key, the <b>OK</b> key, or the <b>↵</b> key.
view the next function or highlight the next option on a list	<b>OK</b> key down or the <b>↓</b> key on the left side of the phone.
move back to the previous function or option on a list	<b>OK</b> key up or the <b>↑</b> key on the left side of the phone.
move back up one level in the menu structure	<b>↶</b> soft key or the <b>C</b> key.
exit the menu structure without changing the settings	<b>☎/⊗</b> key.

In some functions, you may be asked for a password or PIN. Enter the code and press the **OK** soft key.

**Note:** When you access a list of options, your phone highlights the currently active option. If, however, there are only two options, such as **On/Off** or **Enable/Disable**, your phone highlights the option that is not currently active, so that you can select it directly.



# Entering text

When using your phone, you will often need to enter text, such as when storing a name in Phonebook, creating your personal greeting or scheduling events on your calendar. You can enter alphanumeric characters by using your phone's keypad.

Your phone has the following text input modes:

- **T9 mode**

This mode allows you to enter words with only one keystroke per letter. Each key on the keypad has more than one letter; for example, pressing the **5** key once can enter J, K, or L. T9 mode automatically compares the series of keystrokes you make with an internal linguistic dictionary to determine the most likely word, thus requiring far fewer keystrokes than the traditional Alphabet mode.

- **Alphabet mode**

This mode allows you to enter letters by pressing the key labelled with the letter you want. Press the key once, twice, three, or four times until it displays.

- **Number mode**

This mode allows you to enter numbers.

- **Symbol mode**

This mode allows you to enter various symbols and special characters.

## Changing the text input mode

When you are in a field that allows characters to be entered, you will notice the text input mode indicator on the display.

Example: Writing a text message

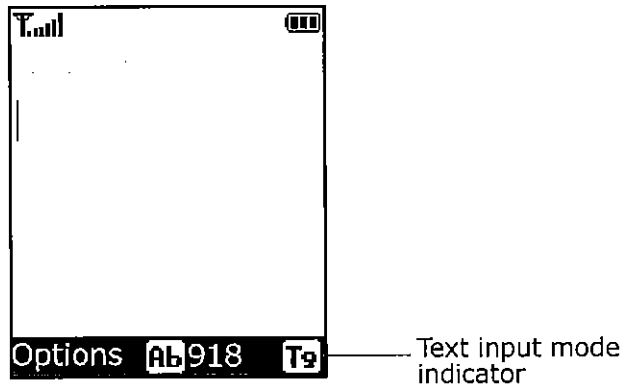

To select	Press the right soft key until
T9 mode	<b>T9</b> displays. See page 38.
Alphabet mode	<b>A</b> displays. See page 40.
Number mode	<b>1</b> displays. See page 41.
Symbol mode	the symbol list displays. See page 41.

**Note:** Additional text input mode may be available, depending upon your country.

## Entering text

### Using T9 mode

---

T9 is a predictive text input mode that allows you to key in any character using single keystrokes. This text input mode is based on a built-in dictionary.

To enter a word in T9 mode:

1. When you are in T9 mode, start entering a word by pressing the **2** to **9** keys. Press each key only once for each letter.

Example: To enter "Hello" in T9 mode, press the **4**, **3**, **5**, **5**, and **6** keys.

The word that you are typing appears on the display. It may change with each key that you press.

2. Enter the whole word before editing or deleting the keystrokes.
3. When the word displays correctly, go to step 4.

If the word doesn't display correctly, press the **0** key or the **OK** key up or down repeatedly to display alternative word choices for the keys that you have pressed.

Example: Both "Of" and "Me" use the **6** and **3** keys. The phone displays the most commonly used choice first.

4. Insert a space by pressing the **#** key and start entering the next word.

To add a new word into the T9 dictionary:

1. After pressing the keys corresponding to the word you want to add, press the **0** key or the **OK** key down to display the alternative words.
2. When there are no more alternative words, the display shows **Add** on the bottom line. Press the **Add** soft key.
3. If necessary, clear the word using the **C** key and enter the word you want to add using Alphabet mode. See page 40.
4. Press the **OK** soft key.

The word is added to the T9 dictionary and becomes the first word for the associated keypress series.

**Note:** This feature may not be available for some languages.

- To enter periods, hyphens, or apostrophes, press the **1** key. T9 mode applies grammar rules to ensure that correct punctuation is used.
- To shift case in T9 mode, use the **\*** key. There are three cases; Initial Capital (**Ab**), Capital lock (**AB**), and Lower case (**ab**).
- You can move the cursor by pressing the **OK** key to the left or right. To delete letters, press the **C** key. Press and hold the **C** key to clear the display.



## Entering text

### Using Alphabet mode

---

Use the **1** to **0** keys to enter your text.

1. Press the keys labelled with the letter you want:
  - Once for the first letter
  - Twice for the second letter
  - And so on
2. Select the other letters in the same way.

**Note:** The cursor moves to the right when you press a different key. When entering the same letter twice or a different letter on the same key, just wait for a few seconds for the cursor to move to the right automatically, and then select the next letter.

Refer to the table below for further details about the available characters:

Key	Characters in the Order Displayed	
	Upper Case	Lower Case
1	. , - ? ! @ : ( ) / 1	
2	A B C 2 Ä Å Æ Ç Γ	a b c 2 à ä å æ Γ
3	D E F 3 É Δ Φ	d e f 3 è é Φ
4	G H I 4 Θ Ψ	g h i 4 ì Ψ
5	J K L 5 Λ	j k l 5 λ
6	M N O 6 Ñ Ø Ö ö	m n o 6 ñ ø ò ö
7	P Q R S 7 Π Σ Ξ	p q r s 7 β Σ Ξ
8	T U V 8 Ü ü	t u v 8 ù ü
9	W X Y Z 9 Ω	w x y z 9 Ω
0	Space + = < > € £ \$ % & ¥ ¤ 0	

**Note:** The characters available in Alphabet mode may be different, depending upon your country.

- To insert a space, press the **#** key.
- To shift case in Alphabet mode, use the **\*** key. There are three cases; Initial Capital (**Ab**), Capital lock (**AB**), and Lower case (**ab**).
- You can move the cursor by pressing the **OK** key to each direction. To delete letters, press the **C** key. Press and hold the **C** key to clear the display.

## Using Number mode

---

Number mode enables you to enter numbers into a text message. Press the keys corresponding to the digits you want to enter.

## Using Symbol mode

---

Symbol mode enables you to insert symbols into a text message.

To	Press the
select a symbol	corresponding number key.
display more symbols	<b>OK</b> key up or down.
clear the symbol(s)	<b>C</b> key. When the input field is empty, this key returns the display to the previous mode.
insert the symbol(s) into your message	<b>OK</b> soft key.
cancel your input and exit Symbol mode	<b>↶</b> soft key.



# Options during a call

Your phone provides a number of control functions that you can use during a call.

## Putting a call on hold

---

You can place the current call on hold whenever you want. You can make another call while you have a call in progress if your network supports this service.

To place a call on hold, simply press the **Hold** soft key. You can reactivate the call whenever you want, by pressing the **Unhold** soft key.

To make a call while you have a call in progress:

1. Enter the phone number that you wish to dial or look it up in Phonebook.

For details about searching for a number in Phonebook, see page 62.

2. Press the  key to dial the second call.

The first call is automatically put on hold.

Or,

1. Put the current call on hold by pressing the **Hold** soft key.
2. Make the second call in the normal way.

## Options during a call

When you have an active call and a call on hold, you may switch between the two calls, changing the one on hold to active and placing the other on hold.

To switch between the two calls, simply press the **Swap** soft key.

The current call is placed on hold and the call on hold is reactivated so that you can continue conversing with that person.

When you want to finish, end each call normally by pressing the /∅ key.

## Using the menu functions

---

You can access the main menu functions during a call.

1. Press the **Options** soft key.
2. Press the **OK** soft key when the **Menu** option highlights.
3. Press the **OK** key up or down to scroll through the menu list.

**Note:** You cannot use some menus during a call. They are deactivated on this list.

4. When the menu you want highlights, press the **Select** soft key.
5. If the selected menu has sub-options, repeat steps 3 and 4.

For further details about available menu functions, see the list on page 52.

## Options during a call

### Switching off the microphone (Mute)

You can temporarily switch your phone's microphone off so that the other person on the phone cannot hear you.

Example: You wish to say something to a person in the room, but do not want the person on the phone to hear you.

To switch the microphone off temporarily:

1. Press the **Options** soft key.
2. Press the **OK** key down to highlight the **Mute** option.
3. Press the **OK** soft key.

The other person can no longer hear you.

To switch the microphone back on:

1. Press the **Options** soft key.
2. If necessary, press the **OK** key down to highlight the **Unmute** option.
3. Press the **OK** soft key.

The other person can hear you again.

## **Muting or sending key tones**

---

The **Mute keys** and **Send keys** options allow you to turn the key tones off or on. If the **Mute Keys** option is selected, your phone does not transmit the DTMF (Dual Tone Multi-Frequency) tones of the keys, which allows you to press keys without hearing annoying key tones during a call.

**Note:** To communicate with answering machines or computerised telephone systems, the **Send keys** option must be selected.

## **Sending a sequence of DTMF tones**

---

You can send the DTMF tones as a group after entering the entire number you need to send.

This option is helpful for entering a password or an account number when you call an automated system, like a banking service.

To send the DTMF tones:

1. While connected to the teleservice system, press the **Options** soft key.
2. Press the **OK** key down to highlight the **Send DTMF** option.
3. Press the **OK** soft key.
4. Enter the number you want to send and press the **OK** soft key.

The tones are sent.

## Searching for a number in Phonebook

---

You can search for a number in Phonebook during a call.

1. Press the **Options** soft key.
2. Press the **OK** key down to highlight the **Phonebook** option.
3. Press the **OK** soft key.

The Phonebook entries are listed.

4. Enter the name that you wish to find.

If you enter the first few letters of the name, the Phonebook entries are listed starting with the first entry matching your input.

5. To view the highlighted entry, press the **View** soft key.

For further details about the Phonebook feature, see page 62.

## Call waiting

---

You can answer an incoming call while you have a call in progress, if your network supports this service and you have set the **Call waiting** menu (**Menu 9.5.3**) to **Activate**; see page 158. You are notified of an incoming call by a call waiting tone.

To answer a call while you have a call in progress:

1. Press the  key to answer the incoming call. The first call is automatically put on hold.
2. To switch between the two calls, press the **Swap** soft key.
3. To end the call on hold, press the **Options** soft key and select the **End held call** option.

To end the current call, press the  key.

## Making a multi-party call

---

A multi-party call is a network service that allows up to six people to take part simultaneously in a multi-party or conference call. For further details about subscribing to this service, contact your service provider.

### Setting up a multi-party call

1. Call the first participant in the normal way.
2. Call the second participant in the normal way. The first call is automatically put on hold.



## Options during a call

3. To join the first participant to the multi-party call, press the **Options** soft key and select the **Join** option. Press the **OK** soft key.
4. To add a new person to the multi-party call, call the new person in the normal way and press the **Options** soft key. Select the **Join** option and press the **OK** soft key.

You can add incoming callers by answering the call, pressing the **Options** soft key, and selecting the **Join** option. Repeat as required.

## Having a private conversation with one participant

1. Press the **Options** soft key and choose the **Select one** option. Press the **OK** soft key.

The list of call participants appears.

2. Highlight a person from the list by pressing the **OK** key up or down, and press the **Select** soft key or the  key.
3. When the **Private** option highlights, press the **OK** soft key.

Now you can talk privately to that person. The other participants can still converse with each other.

4. To return to the multi-party call, press the **Options** soft key and select the **Join** option. Press the **OK** soft key.

All the multi-party call participants can now hear each other.

### Dropping one participant

1. Press the **Options** soft key and choose the **Select one** option. Press the **OK** soft key.

The list of call participants appears.

2. Highlight a person from the list by pressing the **OK** key up or down, and press the **Select** soft key or the  key.

3. Press the **OK** key down to select the **Remove** option and press the **OK** soft key.

The call with that participant ends, but you can continue to talk to the others.

4. When you want to end the multi-party call, close the phone or press the /ⓘ key.



# Using the menus

The phone offers a range of functions that allow you to tailor it to your needs. These functions are arranged in menus and sub-menus.

The menus and sub-menus can be accessed by scrolling or by using the shortcuts.

## Accessing a menu function by scrolling

1. In Idle mode, press the **Menu** soft key to access Menu mode.
2. Scroll to a main menu, **Settings** for example, by pressing the **OK** key to each direction and press the **Select** soft key or the **OK** key.
3. Scroll by pressing the **OK** key up or down to reach a menu, **Phone settings** for example. Press the **Select** soft key or **OK** key to enter the menu.
4. If the menu contains sub-menus, **Language** for example, you can access them by pressing the **OK** key up or down and pressing the **Select** soft key or **OK** key.

If the menu that you have selected contains further options, repeat this step.

5. <b>To</b>	<b>Press the</b>
scroll through the menus	<b>OK</b> key up or down, or use the Volume keys.
confirm the chosen setting	<b>Select</b> soft key, the <b>OK</b> key, or the <b>i</b> key.

5. To	Press the
return to the previous menu level	↶ soft key or the <b>C</b> key.
exit the menu without changing the settings	⏏/⓪ key.

## Using shortcuts

Menu items, such as menus, sub-menus, and options, can be accessed quickly by using their shortcut numbers. For the main menus, you can access any one of them by pressing the number keys (**1** to **9**) corresponding to their location on the screen.

Simply press the **Menu** soft key and enter the number of the menu you want.

### Notes:

- The numbers assigned to each menu are indicated on the list on page 53. They may not match the menu number on the phone, depending on the services supported by your SIM card.
- For the menu number 10, use the **0** key.

Example: Accessing the **Language** menu

1. Press the **Menu** soft key.
2. Press the **9** key for **Settings**.
3. Press the **3** key for **Phone settings**.
4. Press the **1** key for **Language**.

The languages available display.

## List of menu functions

---

The following list shows the menu structure available and indicates the number assigned to each option and the page where you can find a description of each feature.

### 1. Call records (see page 57)

- 1.1 Missed calls
- 1.2 Received calls
- 1.3 Dialed calls
- 1.4 Delete all
- 1.5 Call time
  - 3.5.1 Last call time
  - 3.5.2 Total sent
  - 3.5.3 Total received
  - 3.5.4 Reset timers
- 1.6 Call cost\*
  - 3.6.1 Last call cost
  - 3.6.2 Total cost
  - 3.6.3 Max cost
  - 3.6.4 Reset counters
  - 3.6.5 Set max cost
  - 3.6.6 Price/Unit

### 2. Phonebook (see page 62)

- 2.1 Search
- 2.2 New entry
- 2.3 Group search
- 2.4 Group edit
- 2.5 Speed dial
- 2.6 Delete all
- 2.7 Memory status
- 2.8 Own number
- 2.9 SDN

---

\* Shows only if supported by your SIM card.

**3. Applications** (see page 72)

- 3.1 MP3 payer
- 3.2 Voice memo
  - 3.2.1 Record voice
  - 3.2.2 Voice list
  - 3.2.3 Delete all
  - 3.2.4 Memory status
- 3.3 SIM at menu

**4. Browser** (see page 78)

- 4.1 Home
- 4.2 Bookmarks
- 4.3 http://
- 4.4 WAP profile
- 4.5 Clear cache

**5. Messages** (see page 85)

- 5.1 Text messages
  - 5.1.1 Inbox
  - 5.1.2 Outbox
  - 5.1.3 Create
  - 5.1.4 Templates
  - 5.1.5 Settings
  - 5.1.6 Delete all
  - 5.1.7 Memory status
- 5.2 Multimedia messages
  - 5.2.1 Inbox
  - 5.2.2 Outbox
  - 5.2.3 Create
  - 5.2.4 Draft
  - 5.2.5 Templates
  - 5.2.6 Delete all
  - 5.2.7 Memory status
  - 5.2.8 Settings
  - 5.2.9 MMS profile
- 5.3 Push messages
  - 5.3.1 Inbox
  - 5.3.2 Receive
  - 5.3.3 Delete all

## Using the menus

### **5. Messages** (continued)

- 5.4 Voice mail
  - 5.4.1 Connect to voice server
  - 5.4.2 Voice server number
- 5.5 Broadcast messages
  - 5.5.1 Read
  - 5.5.2 Receive
  - 5.5.3 Channel list
  - 5.5.4 Language

### **6. Funbox** (see page 110)

- 6.1 Games
  - 6.1.1 Java games
  - 6.1.2 3D games
- 6.2 Sounds
- 6.3 Images
- 6.4 Videos
- 6.5 Delete all
- 6.6 Memory status
  - 6.6.1 Games
  - 6.6.2 Sounds
  - 6.6.3 Images
  - 6.6.4 Videos

### **7. Organiser** (see page 120)

- 7.1 Alarm
  - 7.1.1 Once
  - 7.1.2 Daily
  - 7.1.3 Morning call
  - 7.1.4 Remove
  - 7.1.5 Autopower
- 7.2 Calendar
- 7.3 To do list
- 7.4 Calculator
- 7.5 Currency converter

**8. Camera** (see page 128)

- 8.1 Photos
- 8.2 Videos
- 8.3 My album
  - 8.3.1 Photo album
  - 8.3.2 Video album
- 8.4 Delete all
- 8.5 Memory status
- 8.6 Select memory location

**9. Settings** (see page 141)

- 9.1 Time & Date
  - 9.1.1 Set time
  - 9.1.2 Set date
  - 9.1.3 World time
  - 9.1.4 Time format
- 9.2 Phone settings
  - 9.2.1 Language
  - 9.2.2 Greeting message
  - 9.2.3 Infrared activate
  - 9.2.4 Short cut
  - 9.2.5 Extra settings
- 9.3 Display settings
  - 9.3.1 Main LCD
  - 9.3.2 Sub LCD
  - 9.3.3 Menu style
  - 9.3.4 Back light
  - 9.3.5 Service light
  - 9.3.6 Graphic logo
- 9.4 Sound settings
  - 9.4.1 Ring tone
  - 9.4.2 Ring volume
  - 9.4.3 Alert type
  - 9.4.4 Keypad tone
  - 9.4.5 Message tone
  - 9.4.6 Folder tone
  - 9.4.7 Power on/off
  - 9.4.8 Alerts on call
  - 9.4.9 Extra tones



## Using the menus

### 9. Settings (continued)

#### 9.5 Network services

- 9.5.1 Call diverting
- 9.5.2 Call diverting
- 9.5.3 Call warring
- 9.5.4 Network selection
- 9.5.5 Caller ID
- 9.5.6 Closed user group
- 9.5.7 Band selection

#### 9.6 Security

- 9.6.1 PIN check
- 9.6.2 Change PIN
- 9.6.3 Phone lock
- 9.6.4 Change password
- 9.6.5 Privacy
- 9.6.6 SIM lock
- 9.6.7 FDN mode\*
- 9.6.8 Change PIN2\*

#### 9.7 Reset settings

---

\* Shows only if supported by your SIM card.



# Call records

In this menu, you can view the:

- calls you missed, received, or dialled.
- length of your calls.
- cost of your calls, depending on your SIM card.

## Notes:

- You can access the call records of all three types of calls by pressing the  key in Idle mode.
- The number of call records the phone can store may vary, depending on your SIM card.

## Missed calls *(Menu 1.1)*

---

This menu lets you view the 20 most recent calls you received, but did not answer.

The number or name, if available, displays together with the time and date the call was received.

By pressing the **Options** soft key, you can access the following options:

**Edit:** allows you to edit the number, if available, and dial it or save it in Phonebook.

**Delete:** deletes the call from the list.

You can also dial the number by pressing the  key.

## Call records

### **Received calls** *(Menu 1.2)*

---

This menu lets you view the 20 most recent calls you received.

The number or name, if available, displays together with the time and date the call was received.

By pressing the **Options** soft key, you can access the following options:

**Edit:** allows you to edit the number, if available, and dial it or save it in Phonebook.

**Delete:** deletes the call from the list.

You can also dial the number by pressing the  key.

### **Dialled calls** *(Menu 1.3)*

---

This menu lets you view the 20 most recent calls you dialled.

The number or name, if available, displays together with the time and date the call was made.

By pressing the **Options** soft key, you can access the following option:

**Edit:** allows you to edit the number and dial it or save it in Phonebook.

**Delete:** deletes the call from the list.

You can also dial the number by pressing the  key.

## **Delete all** *(Menu 1.4)*

---

This menu allows you to delete all of the records in each call record separately. You can also delete all of your call records at one time.

1. <b>To</b>	<b>Press the</b>
select a call record to clear	<b>OK</b> key up or down. To delete all of your call records, select <b>All calls</b> .
place or remove a check mark	<b>Mark</b> soft key.

2. To delete the marked records, press the **Delete** soft key.
3. When a confirmation message displays, press the **Yes** soft key to confirm.
4. When the display asks for confirmation again, press the **Yes** soft key.

## Call records

### **Call time** *(Menu 1.5)*

---

This menu lets you view the time log for calls made and received.

**Note:** The actual time invoiced by your service provider may vary, depending on network features, rounding-off for billing purposes, and so on.

The following options are available:

**Last call time:** shows the length of the last call.

**Total cent:** shows the total length of all calls you have made since the timer was last reset.

**Total received:** shows the total length of all calls you have received since the timer was last reset.

**Reset timers:** allows you to reset the call timers. You must first enter the phone password and then press the **OK** soft key.

**Note:** The password is preset to "00000000" at the factory. To change this password, see page 164.

## Call cost *(Menu 1.6)*

---

This network feature lets you view the cost of calls. This menu may not be available depending on your SIM card.

The following options are available:

**Last call cost:** shows the cost of the last call you made.

**Total cost:** shows the total cost of all calls you have made since the cost counter was last reset. If the total cost exceeds the maximum cost set in the **Set max cost** option, you can no longer make any calls until you reset the counter.

**Max cost:** shows the maximum cost set in the **Set max cost** option. See below.

**Reset counters:** allows you to reset the cost counter. You must first enter your PIN2 (see page 172) and then press the **OK** soft key.

**Set max cost:** allows you to enter the maximum cost authorised for your calls. You must first enter your PIN2 (see page 172) and then press the **OK** soft key.

**Price/Unit:** allows you to set the cost of one unit; this price per unit is applied when calculating the cost of your calls. You must first enter your PIN2 (see page 172) and then press the **OK** soft key.



# Phonebook

You can store phone numbers and their corresponding names in both your SIM card and your phone's memories. They are physically separate but are used as a single entity, called Phonebook.

## Notes:

- You can quickly enter this menu by pressing the **Phonebook** soft key in Idle mode.
- Depending on your particular SIM card, the maximum number of phone numbers the SIM card can store may differ.

## Search *(Menu 2.1)*

---

In this menu, you can search Phonebook entries by entering names.

1. Enter the first few letters of the name that you want to find.

The Phonebook names are listed, starting with the first entry matching your input.

2. To	Press the
view the highlighted entry	<b>View</b> soft key.
select a different entry	<b>OK</b> key up or down until the entry you want highlights.
look for a name starting with a different letter	key labelled with the letter you want.

3. Once you have found the entry, press the  key to dial the number.

Alternatively, press the **Options** soft key to access the Phonebook entry options; for further details, see page 63.

### Using Phonebook entry options

While accessing any Phonebook entry, press the **Options** soft key to access the options for the entry.

The following options are available:

**Photo caller ID:** allows you to assign one of the photos you took using the camera as a caller ID image to be displayed when you receive a call from the selected number. For details about Camera feature, see page 128.

**Edit:** allows you to edit the name and/or number.

**Copy:** allows you to copy the number to another location. You can select the memory location, either **SIM** or **Phone**, and change the location number.

**Paste:** allows you to paste the number into the normal dialling mode. Use this option to dial a number similar to one in Phonebook, such as a different extension in the same office.

**Delete:** allows you to delete the selected number from Phonebook. You are asked to confirm that you wish to delete the name and number by pressing the **Yes** soft key.



## Phonebook

**Caller group:** allows you to organise your Phonebook entries in caller groups so that the phone alerts you in a specific way when a person from one of your groups calls you. Select one of the ten groups available.

To remove an entry from a group, select the **No group** option.

For further details about how to change caller group properties, see page 67.

**Add entry:** allows you to add a new number to the currently selected name.

**Send via IrDA:** allows you to send the currently selected number or all of the numbers in Phonebook to another phone via the infrared port.

## **New entry** *(Menu 2.2)*

---

This menu allows you to add a new entry into Phonebook.

1. Select an icon to identify the category in which the number is to be stored by pressing the **OK** key to the left or right, and press the **Select** soft key.

**Note:** The E-mail icon () is available in this procedure. It allows you to save an e-mail address instead of a phone number.

2. Select a memory location, either **SIM** or **Phone**, and press the **Select** soft key.



**Note:** When you are saving an e-mail address, SIM is not available.

3. Enter a name and press the **OK** soft key.

For further details about how to enter characters, see page 36.

4. Enter the number or address you want to store and press the **Save** soft key.
5. If you do not want to save the number and name in the suggested location, press the **C** key to clear the location number and enter another location by pressing the number keys.
6. Press the **OK** soft key to store the name and number.

After storing, the phone displays the Phonebook name and number you just stored.

7. <b>To</b>	<b>Press the</b>
use the entry options	<b>Options</b> soft key. For further details, see page 63.
dial the number	 key.
return to the idle screen	 key.

## Group search *(Menu 2.3)*

---

You can search for Phonebook entries by caller group.

1. Enter the first few letters of the group name that you want to find.

The caller groups are listed, starting with the first group matching your input.

2. If necessary, scroll to a group by pressing the **OK** key up or down and press the **View** soft key.

The Phonebook entries in the caller group are listed.

3. <b>To</b>	<b>Press the</b>
view the highlighted entry	<b>View</b> soft key.
select a different entry	<b>OK</b> key up or down until the entry you want highlights.

4. Once you have found the entry, press the  key to dial the number.

Alternatively, press the **Options** soft key to access the Phonebook entry options; for further details, see page 63.

## **Group edit** *(Menu 2.4)*

---

In this menu, you can change the properties of each caller group.

1. Scroll through the group list by pressing the **OK** key up or down.
2. When the group you want highlights, press the **Options** soft key.
3. Select each option and change the settings, as you want. The following options are available:
  - **Call ring tone:** allows you to set a ring tone to be used when you receive a voice call from a member of that group.
  - **SMS tone:** allows you to set a ring tone to be used when you receive a message from a member of that group.
  - **Graphic:** allows you to set a graphic icon to be displayed when you receive a voice call from a person in the group.
  - **Group name:** allows you to assign a name to the group. For further details about how to enter characters, see page 36.
4. After changing the setting, press the **Save** or **OK** soft key.

### **Speed dial** *(Menu 2.5)*

---

You can assign up to eight phone numbers from the Phonebook list that you use most frequently to the number keys (**2** to **9**), and then dial them easily whenever you want, simply by pressing and holding the associated number key.

#### **Setting up speed-dial entries**

1. Select the key to which you wish to assign the speed-dialling number, from the **2** to **9** keys, and press the **OK** soft key.

**Note:** Memory location 1 is reserved for your Voice Mail server number.

If you have already assigned a number to the key, the **Options** soft key replaces the **OK** soft key.

2. Select a name from the Phonebook list and press the **View** soft key.
3. Select a number, if the name has more than one, by pressing the **OK** key up or down and press the **Select** soft key.

Once you have assigned a number to the key, you can use the following options by pressing the **Options** soft key:

**Change:** allows you to assign a different number to the key.

**Delete:** allows you to clear the setting so that no number is assigned to the key.

**Delete all:** allows you to clear the settings for all the keys so that no numbers are assigned to any of the keys.

**Number:** allows you to view the number assigned to the key.

## Speed-dialling

To speed dial the numbers assigned to the **2** to **9** keys, press and hold the appropriate key in Idle mode.

## Delete all *(Menu 2.6)*

---

You can delete all of your entries from your phone's memory, your SIM card or both.

1. <b>To</b>	<b>Press the</b>
select a memory to empty	<b>OK</b> key up or down. To empty both memories, select <b>All</b> .
place or remove a check mark	<b>OK</b> or <b>i</b> key.

- When you have finished marking, press the **Delete** soft key to delete the entries in the selected memory location(s).
- Enter the phone password and press the **OK** soft key.

**Note:** The password is preset to "00000000" at the factory. To change this password, see page 164.

## Phonebook

4. When the confirmation message appears, press the **Yes** soft key.
5. When the display asks for confirmation again, press the **Yes** soft key.

## **Memory status** *(Menu 2.7)*

---

You can check how many names and numbers are stored in Phonebook, in both the SIM card's and the phone's memory. You can also see the capacity of both memories.

Press the **OK** key up or down to view the number of existing and total entries available on the SIM card and in the phone's memory.

## **Own number** *(Menu 2.8)*

---

This function is a memory aid, which you can use to check your own phone numbers if you need to do so.

You can:

- assign a name to each of the own phone numbers registered on your SIM card.
- edit the names and numbers.

Any changes made here do not in any way affect the actual subscriber numbers on your SIM card.

## **SDN (Service Dialling Numbers)** *(Menu 2.9)*

---

You can view the list of Service Dialling Numbers (SDN) assigned by your service provider. These numbers include emergency numbers, directory enquiries and voice mail numbers.

1. Scroll through the numbers by pressing the **OK** key up or down.
2. To dial the number displayed, press the **Dial** soft key or the  key.

**Note:** This menu is available only when your SIM card supports Service Dialling Numbers.





# Applications

Your phone provides you with functions as an MP3 player or a voice recorder.

## **MP3 player** *(Menu 3.1)*

---

You can enjoy music using your phone as an MP3 player.

Before using the MP3 player you first need to save MP3 music files in your phone's memory or an optional memory card. You can download the music files from the Wireless Web or from your computer. For further details about the memory card, see page 21.

**Note:** In Silent mode, you are not able to use the MP3 player, even though the headset is connected to the phone.

### **Playing MP3 files**

1. On the MP3 player screen, press the **OK** key up to view the file list.

By default, the file list stored in the phone's memory displays.

2. Scroll through the file list and press the **OK** or **i** key to select a file. Repeat this step to select more files.

You can remove your check mark(s) by pressing the **OK** or **i** key again.

To play all of the files on the list, select **All**.

**Note:** Some downloaded files may be deactivated on the list if their format is not supported.

3. When you have finished Selecting files, press the **Options** soft key. The following options are available:
  - **Play**: plays the file(s).
  - **Delete**: allows you to delete the file(s).
  - **Properties**: shows you information about the files.
  - **Copy to MMC**: allows you to copy the MP3 file(s) from the phone's memory to a memory card. This option is only available for MP3 files stored in the phone's memory.
  - **Copy to phone**: allows you to copy the MP3 file(s) from the memory card to the phone's memory. This options is only available for MP3 files stored on the memory card.
4. Select the **Play** option and press the **Select** soft key to play the file(s).
5. You can use the following options while playing a file:

To	Press the
view the file list	<b>OK</b> key up.
pause or resume	<b>OK</b> or <b>i</b> key.
skip to the previous file	<b>OK</b> key left.
skip to the next file	<b>OK</b> key right.
adjust the volume	Volume keys.
use MP3 player options	<b>Options</b> soft key. See the following page.
stop	<b>OK</b> key Down.

## Applications

### Using MP3 player options

You can access the following options when you press the **Options** soft key on the MP3 player screen:

**Play all:** allows you to play all of the MP3 files in the currently selected memory location, the phone's memory or memory card.

**Repeat mode:** allows you to set the phone to repeat playback.

**Delete all:** allows you to delete all of the files.

**Sorting:** allows you to change the sorting order of the file list.

**Memory status:** shows the Total, Used, and Free memory amounts for the currently selected memory location. Press the **Next** soft key to view memory space in use for photos, video files, and audio files, individually. At the bottom of the screen is a sliding scale that shows the amount of memory used and available for these features, collectively.

**Select memory location:** allows you to select the default memory location, the phone's memory or memory card, from which to play downloaded MP3 files.

## **Voice memo** *(Menu 3.2)*

---

You can record voice memos. After recording, you can send the memo to other people using the Multimedia Message Service.

### **Record voice** *(Menu 3.2.1)*

This menu allows you to record a new memo. When you select this option, the display shows a 30-second timer.

1. To start recording, press the **Record** soft key.
2. Record a memo by speaking into the microphone.
3. When you press the **Stop** soft key, or if the recording time expires, the following options display:
  - **Replay**: plays back your memo.
  - **Re-record**: discards the memo and enables you to record another one.
  - **Save**: allows you to save the memo.
  - **Quit**: cancels your recording and exits the **Record voice** menu.
4. To save the memo, choose **Save** and press the **Select** soft key.
5. Press the **C** key to clear the default name, if necessary, and enter a name for the memo.

For further details about how to enter characters, see page 36.

## Applications

6. Press the **OK** soft key.

The memo is saved and then the display shows the memo information.

7. Press the **Options** soft key to use the following memo options:
  - **Send:** allows you to send the memo to other people by using the MMS feature. See page 99 for further details about sending a message.
  - **Rename:** allows you to change the memo's name.
  - **Delete:** deletes the memo.
8. To exit, press the **C** or  key.

## Voice list *(Menu 3.2.2)*

This menu shows the list of saved voice memos. Scroll to a memo and press the **Options** soft key. The following options are available:

**Play:** plays the memo.

**Send:** allows you to send the memo to other people by using the MMS feature. See page 99 for further details about sending a message.

**Rename:** allows you to change the memo name.

**Properties:** displays information about the memo, such as the name, the date the memo was made, recording duration, and memory size.

**Delete:** allows you to delete the memo.

### **Delete all** *(Menu 3.2.3)*

In this menu, you can delete all of your voice memos.

### **Memory status** *(Menu 3.2.4)*

You can check the amount of memory being used and the memory remaining for voice memos.

The display shows the Total, Used, and Free memory amount. It also shows the number of the existing memos and the maximum number of memos you can make.

### **SIM AT menu** *(Menu 3.3)*

---

This menu is available if you use a SIM AT card that provides additional services, such as news, weather, sports, entertainment, and location services. Available services may vary, depending on your service provider's plans.

For further details, see your SIM card instructions or contact your service provider.



# Browser

Your phone is equipped with a WAP (Wireless Application Protocol) browser to allow you to access and navigate the Wireless Web using your phone.

## **Home** *(Menu 4.1)*

---

Selecting this menu connects the phone to the network and loads the homepage of the Wireless Web service provider. You can also press the **i** key in Idle mode to launch the browser.

The contents of the WAP Browser startup homepage depends on your Wireless Web service provider. To scroll through the screen, press the **OK** key up or down.

**Note:** To go to the startup homepage from any other screen in the WAP browser, use the **Home** option. For further details about the WAP Browser menus, see page 80.

## **Exiting the WAP browser**

To exit the browser at any time, simply press and hold the  key.

## Navigating the WAP browser

To	Press the
scroll through browser items	<b>OK</b> key up or down.
confirm the selected item	<b>Select</b> soft key.
return to the previous page	<b>Back</b> soft key or the <b>C</b> key.
return to the startup homepage	<b>* </b> key for more than 2 seconds and select the <b>Home</b> option. For further details about this option, see page 80.

## Entering text in the WAP browser

When you are prompted to enter text, the currently active text input mode is indicated on the screen. To change the text input mode, press the **i** key one or more times.

The following modes are available:

**Upper-case Character mode (A)**: allows you to enter upper-case English characters.

**Lower-case Character mode (a)**: allows you to enter lower-case English characters.

**T9 mode (T9)**: allows you to enter English characters by pressing one key per letter. In this mode, you can use only the **0** key to display alternative words. To change case, press the **\*** key.

**Number mode (1)**: allows you to enter numbers.



## Browser

### Selecting and using browser menu options

Various menu options are available when you are using the WAP browser to navigate the Wireless Web.

To access a menu option:

1. Press and hold the **\***  key.  
A menu list displays.
2. Highlight a menu by pressing the **OK** key up or down.
3. Select an option by pressing the **Select** soft key.
4. If necessary, select a secondary option by pressing the **OK** key up or down, and press the **Select** soft key to confirm.

**Note:** The menus may vary, depending on your version of the WAP browser.

The following options are available:

**Bookmarks:** shows the bookmark list. You can bookmark the current web page or access one of bookmarked pages.

**Reload:** reloads the current page.

**Home:** takes you back at any time to the home page of the Wireless Web service provider.

**Go to URL:** allows you to manually enter the URL address of a Web page. After entering an address, press the **Ok** soft key to go there directly.

**Show URL:** displays the URL address of the Web page to which you are currently connected. It also enables you to set the current site as the startup home page.

<b>To</b>	<b>Press the</b>
set the current page as your startup home page	<b>Option</b> soft key and select the <b>Save to home</b> option.
set a bookmark for the current page	<b>Option</b> soft key and select the <b>Save to bookmark</b> option.
cancel your setting	<b>Back</b> soft key.

**Clear cache:** deletes the information stored in the cache, which stores the most recently accessed Web pages.

**Security info:** shows security information when you access the Wireless Web with the secured WAP setting activated.

**Inbox:** allows you to read messages received from the web server.

**Show images:** shows the images on the current web page in order. Press the **Next** soft key to view the next images.

## Browser

### **Bookmarks** *(Menu 4.2)*

---

This menu allows you to store the URL addresses of up to ten of your favourite web sites. You can access this menu directly by pressing and holding the # key while using the WAP browser.

To store a URL address:

1. Select an empty location and press the **Options** soft key.
2. Enter the address and press the **Enter** soft key.  
For further details about how to enter characters, see page 36.
3. Enter a name for the item and press the **Enter** soft key.

After saving an item, you can use the following options by pressing the **Options** soft key:

**Go to URL:** quickly takes you to the site.

**Edit:** allows you to edit the address and name.

**Delete:** deletes the bookmark.

### **http://** *(Menu 4.3)*

---

This menu allows you to manually enter the URL address of a Web site that you wish to access.

For further details about how to enter characters, see page 36.

## **WAP profile** *(Menu 4.4)*

---

This menu allows you to set up five proxy servers for the WAP browser. Contact your service provider for details about your Settings options.

For each server, the following options are available:

**Profile name:** enter a name that you wish to assign to the HTTP server.

**Homepage URL:** set the address of your startup homepage. When the default homepage displays, you can delete it using the **C** key and enter your own choice.

**Security:** select a data transmission mode. Choose **Secure** to protect your data against unauthorised access; otherwise, choose **Non-secure**.

**Bearer:** select a bearer to be used for each type of network address accessed; **GPRS** or **Data**. The remaining options depend on the Bearer setting.

When the bearer is set to **GPRS**:

**IP address:** enter the WAP gateway address required to connect to the Internet.

**User name:** enter the User ID required to connect to the GPRS network.

**Password:** enter the password required to connect to the GPRS network.

**APN:** enter the access point name used for the address of the GPRS network gateway.

When the bearer is set to **Data**:

**IP address:** enter the WAP gateway address required to connect to the Internet.

## Browser

**Login name:** enter the PPP server login ID.

**Password:** enter the PPP server password.

**Dial-up number:** enter the PPP server phone number.

**Data call type:** select a data call type; **Analogue** or **ISDN**.

**Note:** The WAP browser settings may vary, depending on the service provider. Contact your service provider for further details.

## **Clear cache** *(Menu 4.5)*

---

You can clear the information stored in the cache, the phone's temporary memory in which the most recently accessed Web pages are stored.

Press the **Yes** soft key to confirm the deletion. Otherwise, press the **No** soft key.



# Messages

Using the **Messages** menu, you can use various message features, such as:

- text messages
- multimedia messages
- WPP push messages
- voice mail
- broadcast messages

## **Text messages** *(Menu 5.1)*

---

Short Message Service (SMS) allows you to send and receive short text messages to and from other GSM mobile phones. In addition, your phone supports the Enhanced Messaging Service (EMS), which enables you to include photos, melodies, and animated images in your messages.

The Text Message icon () appears when you have received new text messages. If the memory is full, an error message displays and you will be unable to receive any new messages. Use the **Delete** option in each message box to delete unwanted messages.

## **Inbox** *(Menu 1.1.1)*

This message box is used to store messages that you have received.

When you enter this menu, the list of messages in the box displays with the senders' phone numbers or names, if available in your Phonebook.

## Messages

To read a message:

1. Select a message from the list and press the **View** soft key to read the message contents.
2. Press the **OK** key up or down to scroll through the contents.
3. Press the \* or # key to scroll to the previous or next message.

While reading a message, you can choose the following options by pressing the **Options** soft key:

**Delete:** allows you to delete the message.

**Send:** allows you to send/resend the message. For further details about how to send a message, see page 88.

**Text reply:** allows you to send a reply to the sender.

**Call back:** allows you to call the sender.

**Save address:** allows you to extract the sender's number and URL, e-mail addresses or phone numbers from the message text.

**Move to phone:** allows you to move the message from the SIM card to the phone's memory. This option is only available for messages stored in the SIM card.

**Move to SIM:** allows you to move the message from the phone's memory to the SIM card. This option is only available for messages stored in the phone's memory.

**Select content:** allows you to save media items, such as sounds or images, from the message into your phone. You can then use these items when writing a message. For details, see page 90.

### **Outbox** *(Menu 5.1.2)*

This message box is used to store messages that you have sent or will send.

When you enter this menu, a list of messages in the box displays with the recipients' phone numbers or names, if available in your Phonebook.

To read a message:

1. Select a message from the list and press the **View** soft key to read the message contents.
2. Press the **OK** key up or down to scroll through the contents.
3. Press the \* or # key to scroll to the previous or next message.

While reading a message, you can choose the following options by pressing the **Options** soft key:

**Delete:** allows you to delete the message.

**Send:** allows you to send/resend the message. For further details about how to send a message, see page 88.

**Save address:** allows you to extract the destination number and URL, e-mail addresses or phone numbers from the message text.

**Move to phone:** allows you to move the message from the SIM card to the phone's memory. This option is only available for messages stored in the SIM card.

**Move to SIM:** allows you to move the message from the phone memory to the SIM card. This option is only available for messages stored in the phone's memory.



## Messages

**Select content:** allows you to save media items, such as sounds or images, from the message into your phone. You can then use these items when writing a message. For details, see page 90.

### **Create** *(Menu 5.1.3)*

In this menu, you can write and send text messages.

**Note:** When you add media items to a message, the number of characters you are allowed to enter decreases.

### **Creating a simple text message**

1. Create your message.

**Note:** For further details about entering characters, see page 36.

2. When you have finished entering the message, press the **Options** soft key. The following options are available:

**Note:** Pressing the **i** or **OK** key on the message screen directly selects the first option, **Send only**.

- **Send only:** allows you to send the message. The message is then deleted after sending.
- **Save and send:** allows you to first save a copy of the message and then sends the message. You can read the message in your Outbox.
- **Save only:** allows you to save the message to be sent at a later time. You can read the message in your Outbox.

- For further content details about **Text formatting**, **Add content**, **Add templates**, **Add from phonebook**, **Add from bookmark** and **Language** options, see page 89.

3. Select **Send only** or **Save and send**, and press the **Select** soft key.

If you want to just save the message, select **Save only**. After saving the message, the phone returns to the **Text messages** menu screen.

4. If you select a save option, choose the memory location and press the **OK** soft key.
5. Enter a destination number and press the **OK** soft key.

The message is sent.

**Note:** If the phone fails to send the message, it will ask you if you want to retry. Press the **OK** soft key to confirm. Otherwise, press the **Exit** soft key to return to the Create screen.

### Creating a message using options

1. Create a message.
2. Press the **Options** soft key.
3. Select one of the following options by pressing the **OK** key up or down and press the **Select** soft key:

- **Text formatting:** allows you to format the style of the text.

For the **Size** attribute, **Normal**, **Large**, and **Small** sizes are available.

## Messages

For the **Bold**, **Italic**, **Underline** and **Strikethrough** attributes, select **On** or **Off**.

These attributes can be combined.

- **Add content:** allows you to add a sound, melody, picture, or animated image to the message. Select the category of the object to be added. In each category, you can select from the various factory-set items or choose an item received from other sources, such as the Internet or other phones.
  - **Add templates:** allows you to apply one of the preset message templates to the text. Select one of five items stored in the **Templates** menu (**Menu 5.1.4**). For further details, see page 91.
  - **Add from phonebook:** allows you to add a Phonebook entry to your message. Select one from the list.
  - **Add from bookmarks:** allows you to add a web page address stored in your Bookmarks list (**Menu 4.2**). Select one from the list.
  - **Language:** allows you to change the language to be used in T9 input mode. Select the language to be used.
4. Complete the message, and send or save it by following the procedure from step 2 on page 88.

### **Templates** *(Menu 5.1.4)*

Using this menu, you can preset a maximum of five messages that you most frequently use.

Select an empty location or one of the message templates and press the **Select** soft key.

The following options are available:

**Edit:** allows you to write a new message template or edit the message template.

**Note:** For further details about how to enter characters, see page 36.

**Send message:** allows you to retrieve the message template. Once you have completed the message, you can send, save and send, or simply save it. For further details about how to send a message, see page 88.

**Delete:** allows you to delete the message template.

### **Settings** *(Menu 5.1.5)*

In this menu, you can set up default message information. A setting group is a collection of settings required to send messages. The number of setting groups available depends on the capacity of your SIM card.

#### **Notes:**

- The setting options available in this menu may vary, depending on your service provider.
- The last setting you accessed is automatically activated for sending subsequent messages.

## Messages

**Setting x** (where **x** is the setting group number): each group has its own sub-menu.

Setting name: allows you to give a name to the setting group currently being defined.

Service centre: allows you to store or change the number of your message centre, which is required when sending messages. You must obtain this number from your service provider.

Default destination: allows you to store the default destination number. The number automatically displays on the Destination screen when you create a message.

Default type: allows you to set a default message type to **Text**, **Fax**, **Email**, or **Paging**. The network can convert the messages into the selected format.

Validity period: allows you to set the length of time your text messages are stored in the message centre while attempts are made to deliver them.

**Common setting**: The following options are available:

Reply path: allows the recipient of your message to send you a reply through your message centre, if your network supports this service.

Delivery reports: allows you to activate or deactivate the report function. When this function is activated, the network informs you whether or not your message has been delivered.

Bearer selection: allows you to choose either **GSM** or **GPRS**, depending on your network.

Character support: allows you to choose a character type from **GSM-alphabet**, **Uni-code**, or **Automatic**. If you select **Uni-code** and your recipient's phone does not support it, the recipient may not be able to read your message.

### **Delete all** (Menu 5.1.6)

This menu allows you to delete all of the text messages in each message box separately. You can also delete all of your messages at one time.

1. <b>To</b>	<b>Press the</b>
select a message box to clear	<b>OK</b> key up or down. To delete all of your messages, select <b>All messages</b> .
place or remove a check mark	<b>i</b> or <b>OK</b> key.

2. To delete the marked messages, press the **Delete** soft key.
3. When a confirmation message displays, press the **Yes** soft key to confirm.
4. When the phone asks for confirmation again, press the **Yes** soft key.

## Messages

### **Memory status** *(Menu 5.1.7)*

This menu shows the memory status and how many messages are currently stored in the SIM card, Phone and Broadcast memories.

Each time you select a memory, a pop-up box shows the number of existing messages and the maximum number of messages the memory can store.

### **Multimedia messages** *(Menu 5.2)*

---

Multimedia Message Service (MMS) is a messaging service which provides delivery of personal multimedia messages from phone to phone or from phone to e-mail.

In addition to the familiar text content of text messages, multimedia messages can contain images, graphics, voice, and audio clips. An MMS message is a multimedia presentation in a single file entry. It is not a text file with attachments.

Using the MMS feature, your phone can receive and send messages that contain multimedia files, such as your photos, videos, sounds, and images you downloaded from the Internet and voice memos you recorded. This function is available only if it is supported by your service provider. Only phones that offer multimedia messaging features can receive and display multimedia messages.

### **Inbox** *(Menu 5.2.1)*

#### **Viewing a message when you receive it**

When a new multimedia message comes in, the display shows the MMS Message icon (  ) and a text notification along with the sender's number.

1. Press the **Select** soft key to view brief information about the message, such as the sender's number, the message size and the subject.

If you want to view the message later in the Inbox, press the **Exit** soft key.

2. Press the **OK** key up or down to scroll through the message information.
3. Press the **Options** soft key to use the following options:
  - **Retrieve**: retrieves the message from the MMS server.
  - **Delete**: deletes the message.
  - **More properties**: shows you detailed information about the message.

4. To read the message, press the **Select** soft key when **Retrieve** is highlighted.

Your phone retrieves the message contents from the server and displays it.







5. Press the **OK** key up or down to scroll through the message.
6. When you are finished, press the /⓪ key.



## Messages

### Viewing a message from the Inbox

When you access the **Inbox** menu (**Menu 5.2.1**), the list of multimedia messages you have received displays, along with the subjects. The icons on the left tell you the status of the messages.

- : MMS notifications that have been opened.
- : MMS notifications that have not been opened.
- : You have sent an enquiry to the MMS server requesting the message to be sent to your phone.
- : The MMS server is processing your request.
- : The MMS server is unable to send the message to your phone.
- : Messages that have been opened.
- : Messages that have not been opened.

To read a message:

1. Select a message on the list and press the **Select** soft key.

The display presents the message and scrolls to the next page, if it has one, after a specified time.

2. Press the **OK** soft key to go to the message view screen.

Or, the display automatically switches to the screen after a specified time.

3. Press the **OK** key up or down to scroll through the message.

If the message has more than one page, you can scroll through the pages by using the **OK** key left or right.

4. Press the \* or # key to scroll to the previous or next message.

While viewing a message, you can choose the Message options by pressing the **Options** soft key.

If you are viewing a new message, the options are the same as when you view a message at the time of its receipt. See the previous section.

When you are reviewing a message retrieved from the MMS server, the following options are available:

**Delete:** deletes the message.

**Reply:** allows you to reply to the sender by sending a text or multimedia message.

**Call back:** allows you to call the sender.

**Save address:** allows you to extract the sender's number or e-mail address and URL, other e-mail addresses or phone numbers from the message text.

**Forward:** allows you to forward the message to another person.

**Save picture:** allows you to save an image from the message into your phone. Images are stored in the **Images** folder (**Menu 6.3**).

**Save sound:** allows you to save a sound from the message into the **Sounds** folder (**Menu 6.2**).





**Save video:** allows you to save a video from the message into the **Videos** folder (**Menu 6.4**).

**Properties:** shows you information about the message, such as the subject, sender's e-mail address or phone number, message size, recipient's e-mail address or phone number, its priority, and the time and date the message was received.

## Messages

### Outbox *(Menu 5.2.2)*

When you access this menu, the list of multimedia messages that you have sent or saved displays. The icons on the left tell you the status of each message.

- : Messages currently being sent
- : Messages sent
- : Messages your phone couldn't send
- : Messages to be sent
- : Messages deferred

To read a message:

1. Select a message on the list and press the **Select** soft key.

The display presents the message and scrolls to the next page, if it has one, after a specified time.

2. Press the **OK** soft key to go to the message view screen.

Or, the display automatically switches to the screen after a specified time.

3. Press the **OK** key up or down to scroll through the message.

If the message has more than one page, you can scroll through the pages by pressing the **OK** key left or right.

4. Press the \* or # key to scroll to the previous or next message.

While viewing a message, you can choose the following options by pressing the **Options** soft key:

**Delete:** deletes the message.

**Save address:** allows you to extract the destination numbers or e-mail addresses and URL, e-mail addresses or phone numbers from the message text.

**Send:** allows you to resend the message.

**Edit message:** allows you to change the message contents, such as a sound, a photo, or text.

**Properties:** shows you information about the message, such as the status, subject, sender's e-mail address or phone number, message size, and the time and date the message was sent.

### **Create** (*Menu 5.2.3*)

This menu allows you to create a new multimedia message and send it to one or multiple destinations.

### **Creating and sending a multimedia message**



1. Enter the subject of your message and press the **OK** soft key.

For further details about entering characters, see page 36.

2. When **Add here** highlights, press the **Options** soft key and add the message contents using one of the following options:

- **Add text:** enter the message text and press the **OK** soft key.

## Messages

- **Add image:** allows you to add an image. You can take a new photo or select one of the photos taken by using the camera, downloaded from the web, or received in messages. For further details about using the camera, see page 128.
- **Add video:** allows you to add a video. You can record a new video or select one of the videos recorded by using the camera, downloaded from the web, or received in messages.
- **Add sound:** allows you to add a sound file. You can record a new voice memo or select one of the memos recorded, downloaded from the web, or received in messages. For further details about using the Voice Memo feature, see page 75.
- **Send:** allows you to send the message.
- **Save:** allows you to save the message in the **Draft (Menu 5.2.4)** or **Templates (Menu 5.2.5)** box for later use. This option is activated after you add contents to the message.
- **Settings:** allows you to change the message settings. For further details about each setting option, see page 105. After changing the settings, you need to press the  soft key or the **C** key to go to back to the Options screen.
- **Add destination:** allows you to enter destination numbers or addresses. See steps 6 to 11. After adding them, you need to press the  soft key or the **C** key to go to back to the Options screen.
- **Preview:** shows your message.

### Notes:

- For downloaded media items, you may not be able to add them if they are not in correct format.
- When you add a video, you are not able to add an image and a sound.

3. Repeat step 2 until you have finished creating your message.
4. If you want to change the added items, press the **OK** key up or down to highlight one and press the **Options** soft key.

**Note:** The available options are different, depending on whether the item you select on the message screen is text, an image, a sound or the Page field.

The following options are available:

- **Edit text/image/video/sound:** allows you to change the text or replace the image or sound with another one.
- **Add page:** allows you to add more pages. After you add a page, the display shows you the current page number and the memory space used for the page. You can move to each page by pressing the **OK** key left or right on the message screen.
- **Delete:** deletes the item from your message.
- **Duration:** allows you to set when and how long text, an image, a sound, or a page displays on the message presentation screen. If the duration you set is shorter than the content duration (for example, the length of a sound clip) for a particular page, the content duration is automatically decreased.

## Messages

- **Send:** allows you to send the message.
  - **Save:** saves the message in the **Draft (Menu 5.2.4)** or **Templates (Menu 5.2.5)** box for later use.
  - **Settings:** allows you to change the message settings. For further details about each setting option, see page 105.
  - **Add destination:** allows you to enter destination addresses. See steps 6 to 11.
  - **Preview:** shows your message as it will display on the recipient's phone.
5. When you have finished creating the message, choose **Send** and press the **Select** soft key.
  6. Select a destination type, (**To**, **Cc**, or **Bcc**), and press the **Select** soft key.
  7. Choose one of the following options and press the **Select** soft key:
    - **Phone number:** allows you to enter the phone number you want.
    - **E-mail:** allows you to enter the e-mail address of the recipient.
    - **Phonebook:** allows you to retrieve a number from your Phonebook.
  8. Enter a number or an e-mail address, or select one from Phonebook.
  9. When the correct number or address displays, press the **OK** soft key.

10. To add a destination, scroll to **Add destination** and press the **Select** soft key. Repeat from step 7.

If you want to edit the destinations, select one and press the **Select** soft key. You can change or delete it.

11. To enter additional numbers or addresses to the other destination types, press the **C** key or the  soft key and repeat steps 6 through 10.

You can enter up to 10 destinations each for **To**, **Cc**, and **Bcc**.

12. When you have finished entering the destinations, select **Send message** and press the **Select** soft key.

Your phone sends the message.

### **Draft** *(Menu 5.2.4)*

After creating a multimedia message, you can store it in this message box to be sent at a later time.

For further details about viewing a message, see "Outbox" on page 98.

### **Templates** *(Menu 5.2.5)*

This menu stores messages you saved as templates so that you can use them to make new messages.

1. Scroll through the template list by pressing the **OK** key up and down.
2. When the message template you want highlights, press the **Select** soft key.



## Messages

3. Press the **OK** soft key to use the following options, or the display automatically shows the options after a specified time:
  - **Edit message:** allows you to send a message using the template. For further details about how to send a message, see page 88.
  - **Delete:** allows you to delete the message template. You are asked to confirm the deletion by pressing the **Yes** soft key.
4. Press the  key to return to Idle mode.

### **Delete all** (Menu 5.2.6)

This menu allows you to delete all of the multimedia messages in each message box separately. You can also delete all of your messages at one time.

1. <b>To</b>	<b>Press the</b>
select a message box to clear	<b>OK</b> key up or down. To delete all of your messages, select <b>All messages</b> .
place or remove a check mark	<b>i</b> or <b>OK</b> key.

2. To select a message box to clear, press the **Delete** soft key.
3. When a confirmation message displays, press the **Yes** soft key to confirm.
4. when the display asks for confirmation again, press the **Yes** soft key.

### **Memory status** *(Menu 5.2.7)*

You can check the amount of the memory being used and the memory remaining for multimedia messages.

The display shows the Total, Used, and Free memory amount. It also shows how much space is currently occupied by each message box, and the number of existing messages and the maximum number of messages the phone can store.

### **Settings** *(Menu 5.2.8)*

You can change the default settings for sending or receiving multimedia messages.

The following options are available:

**Delivery report:** when this option is enabled, the network informs you whether or not your message has been delivered.

**Read reply:** when this option is enabled, your phone sends a request for a reply along with your message to the recipient.

**Auto download:** you can set whether or not your phone retrieves new incoming messages from the MMS server without notifications. When this option is enabled, the phone automatically retrieves new messages from the server. As soon as you receive a message, you can use more options while you are reading. See page 97 for further details about the options.

**Message acceptance:** you can specify the category of messages you want to receive.

## Messages

**Hide ID:** when this option is enabled, your phone number does not display on the recipient's phone.

**Expiry period:** you can select the length of time your messages are stored in the message centre after they are sent.

**Delivery time:** you can set a time delay before the phone sends your messages.

**Priority:** you can select the priority level of your messages.

**Report allowed:** when this option is enabled, the sender of an incoming message receives a delivery report from the network.

**Page duration:** you can set the length of time one page of an outgoing message displays on the message presentation screen. After a specified time, the display automatically scrolls to the next page.

### **MMS profile** *(Menu 5.2.9)*

In this menu, you can configure various network settings that are required when you send or receive multimedia messages.

#### **Notes:**

- The last profile you accessed is automatically activated for sending subsequent messages.
- If you change the MMS settings without first checking with your service provider, the MMS feature may not work properly.

The following options are available for each profile:

**Profile name:** enter a name that you wish to assign to the MMS server.

**Connection URL:** enter the address of your MMS server.



**Security:** select a data transmission mode. Choose **Secure** to protect your data against unauthorised access; otherwise, choose **Non-secure**.

**IP address:** enter the gateway address required to connect to the MMS server.

**User name:** enter the user ID required to connect to the MMS server.

**Password:** enter the password required to connect to the MMS server.

**APN:** enter the access point name used for the address of the MMS server.

For further details, contact your service provider.

### **Push message** *(Menu 5.3)*

---

In this menu, you can receive and access web messages from the server.

The following options are available:

**Inbox:** allows you to read the messages received from a web server.

**Receive:** allows you to set whether or not your phone receives web messages. Select **Always** to receive web messages, or **Never** to reject web messages.

**Delete All:** allows you to delete all of the web messages.

## Messages

### **Voice mail** *(Menu 5.4)*

---

This menu allows you to access your voice mailbox, if your network supports this service.

#### **Connect to voice server** *(Menu 5.4.1)*

Before using the Voice Mail feature, you must enter the voice server number obtained from your service provider. You can then select this menu and press the **OK** soft key to listen to your messages.

You can quickly connect to the voice server by pressing and holding the **1** key in Idle mode.

#### **Voice server number** *(Menu 5.4.2)*

This menu allows you to change the voice mail server number, if necessary.

**Note:** Voice Mail is a network feature. Please contact your service provider for further details.

### **Broadcast messages** *(Menu 5.5)*

---

This network service allows you to receive text messages on various topics, such as the weather or traffic. Broadcast messages display as soon as they are received, provided that:

- the phone is in Idle mode.
- the **Receive** option is set to **Enable**.
- the message channel is currently active on the channel list.

The following options are available:

**Read:** lets you view the received message. The **Volatile** box displays messages from the network, but erases its contents as soon as the phone is switched off. Scroll through the message by pressing the **OK** key up or down.

You can save a broadcast message in the **Archive** box for later retrieval when a text notification appears, press the **Options** soft key and select **Save**.

**Receive:** allows you to enable or disable the reception of broadcast messages.

**Channel list:** allows you to indicate the channels from which you wish to receive broadcast messages. The following options are available:

Select: use to enable or disable channels on the list by marking or unmarking them respectively. A check mark displays in front of each selected channel.

Add channel: use to enter the ID and title for a new channel.

Delete: use to remove a channel from the list.

Edit: use to change the ID and title of an existing channel.

**Language:** allows you to select your preferred language to display the broadcast messages.

Please contact your service provider for further details.



# Funbox

The **Funbox** menu stores games, images and sounds downloaded from the Wireless Web.

## **Games** *(Menu 6.1)*

---

You can download games and MIDlets (Java applications that run on mobile phones) from various sources using the WAP Browser, and store them in your phone.

### **Java games** *(menu 6.1.1)*

When you access the **Java games** menu, the list of default games appears. Once you have downloaded games, they are added to the list.

**Note:** Java services may not be available, depending upon your service provider.

### **Launching a MIDlet**

**Note:** The procedure explained below is for the default games. For downloaded games, the procedure may be different.

1. Scroll to the MIDlet you want on the Games list and press the **OK** or **i** key.
2. On the startup screen of the MIDlet, scroll to an option by pressing the **OK** key to each direction.

The following options are available:

- **START GAME:** starts a new game.
- **CONTINUE:** allows you to continue the last game you played, if you were interrupted during the game.

- **HIGH SCORE:** shows the high score table. This option may not be available for some games.
- **HOW TO PLAY:** shows how to play the game and the key functions for the game.
- **OPTION:** allows you to switch on or off the game sound.

3. Press the **OK** or **z** key to confirm your selection.

<b>While you are playing a game, to</b>	<b>Press the</b>
adjust the sound volume	Volume keys.
stop the game and return to the startup screen	<b>C</b> key.
exit the game	 /⓪ key.

### Viewing MIDlet information

1. Scroll to the MIDlet you want and press the **Info** soft key.

The display shows information about the MIDlet, such as the file size, application version and its vendor, and Java VM version. You can also check whether or not the MIDlet can be deleted.

2. Press the **OK** key up or down to scroll through the information.
3. Press the **OK** key left or right to scroll to other MIDlet information.





## Funbox

4. If you want to delete the MIDlet, press the **Delete** soft key and then press the **Yes** soft key to confirm the deletion.
5. To exit and return to the Games list, press the **S** soft key or the **C** key.

## Entering text

If you need to enter text while using a MIDlet, you can use the following input modes:

**Upper-case Character mode (A)**: allows you to enter upper-case English characters.

**Lower-case Character mode(a)**: allows you to enter lower-case English characters.

**Number mode (1)**: allows you to enter numbers.

**Symbol mode**: allows you to enter symbols. After highlighting a symbol by pressing the Navigation keys, press the **OK** or **i** key to insert it.

**T9 mode (T9)**: allows you to enter English characters by pressing one key per letter. In this mode, you can change the case by pressing the **0** key.

To change the text input mode, press the **\*** key until the appropriate indicator appears on the soft key area of the display.

## Changing the DNS settings

The DNS (Domain Name Server) is the server that assigns the Java server domain name to an IP address. The DNS setting is preset at the factory, but sometimes you may need to change it at your service provider's instructions.



To change the DNS settings:

1. Scroll to **DNS Setting** on the Games list and press the **OK** or **i** key.
2. Enter the primary address using the number keypad and press the **OK** soft key.
3. Enter the secondary address and press the **OK** soft key.

### **3D games** *(Menu 6.1.2)*

In this menu, you can enjoy 3D games stored on your phone.

#### **Metalion**

1. On the Games list, select **Metalion** and press the **Select** soft key.
2. Press any key to launch the game.
3. Press the **OK** key to each direction or press the **2, 4, 6, or 8** key to move through the choices and press the **5, OK, or i** key to select one.

The phone displays the following options:

- **START GAME:** allows you to start a new game.
- **OPTION:** allows you to choose options (see step 4 below).
- **HIGH SCORE:** shows you the high score table.
- **ABOUT:** shows you information about the developers of Metalion.
- **EXIT:** allows you to exit the current screen.



## Funbox

### 4. Select **START GAME**.

To access the following options, select **OPTION**.

- **DIFFICULTY**: allows you to change the game's level of difficulty.
- **SOUND ON/OFF**: allows you to turn the game sound on or off.
- **GRAPHIC EFFECT**: allows you to change the graphic effects.
- **EXIT OPTION**: allows you to exit the current screen.

### 5. Select a character by pressing the **OK** key left or right or pressing the **4** or **6** key, and press the **5**, **OK**, or **z** key.

### 6. Press any key to start the game.

## Bomb

### 1. On the Games list, select **Bomb** and press the **Select** soft key.

### 2. Press any key to launch the game.

### 3. Press the **OK** key up or down, or press the **2** or **8** key to move through the choices and press the **5**, **OK**, or **z** key to select one.

The phone displays the following options:

- **Start Game**: allows you to start a new game.
- **Records**: shows you the high score table.
- **Option**: allows you to choose options; see step 4 below.
- **How To Play**: shows you how to play the game.

- **Credit:** shows you information about the developers of Bomb.
- **Exit:** allows you to exit the current screen.

#### 4. Select **Start Game**.

To access the following options, select **Option**:

- **Theme:** allows you to select a game theme, Cube or Bomb.
- **Sound:** allows you to turn the game sound on or off.
- **Item:** allows you to set whether or not you use items having special functions.
- **Reset HighScore:** resets the high score records.
- **Back:** goes back to the previous screen. You need to select this option after changing any options.

#### 5. Select a mode either **Normal** or **Mission** and press the **5**, **OK**, or **i** key to start the game.

### ZioGolf

1. On the Games list, select **ZioGolf** and press the **Select** soft key.
2. Press the **OK** key up or down, or press the **2** or **8** key to move through the choices and press the **5**, **OK**, or **i** key to select one.

The phone displays the following options:

- **New Game:** allows you to start a new game.
- **Load Game:** allows you to restart a saved game.
- **Best Score:** shows you the high score table.



## Funbox

- **Credit:** shows you information about the developers of ZioGolf.
- **Exit:** allows you to quit the game.

3. Select **New Game**.
4. Select a player by pressing the **OK** key left or right or pressing the **4** or **6** key, and press the **5**, **OK**, or **i** key.
5. Enter a name for the player and press the **i** key.
6. To start the game, press the **5**, **OK**, or **i** key.
7. Press the **3** key and select a club.
8. Press the **1** key and then select the direction of the stroke by pressing the **OK** key left or right.

**Note:** You can check the course by pressing the **OK** key up or down.

9. Press the **5**, **OK**, or **i** key to select the stroke power level, and then press the **5**, **OK**, or **i** key when the white line is near the "0" mark.

Repeat this step until you are on the green.

10. When you are on the green, select the direction of your putting, according to the level of the surface shown on the top right of the display, by pressing the **OK** key left or right and then press **OK** key.

Each time you finish a hole, the display shows your score. When you have finished 18 holes, a game is over.

## **Sounds** *(Menu 6.2)*

---

In this menu, you can view the list of sounds downloaded from a web server or received in multimedia messages.

Scroll to a sound and press the **Play** soft key to listen to the sound.

By pressing the **Options** soft key, you can access the following options:

**Rename:** allows you to change the name of the sound.

**Delete:** deletes the sound.

**Set as ring tone:** sets the sound as your ring tone.

## **Images** *(Menu 6.3)*

---

In this menu, you can view the list of photos downloaded from a web server or received in messages.

If you set a photo as your wallpaper, it is designated as **My photo** on the list.

Scroll to an image and press the **View** soft key to review the image.

By pressing the **Options** soft key, you can access the following options:

**Rename:** allows you to change the name of the image.

**Delete:** deletes the image.

**Set as wallpaper:** sets the image as your wallpaper for the idle screen.



## Funbox

### Videos *(Menu 6.4)*

---

In this menu, you can view the list of video files downloaded from a web server or received in messages.

Scroll to the video you want and press the **Play(??)** soft key to play the video.

By pressing the **Options** soft key, you can access the following option:

**Rename:** allows you to change the name of the video.

**Delete:** deletes the video.

**Set as wallpaper:** sets the video as your wallpaper for the idle screen.

### Delete all *(Menu 6.5)*

---

This menu allows you to delete all of the downloaded contents in the **Games**, **Sounds**, **Images**, and **Videos** folders separately. You can delete all of the items at one time.

1. <b>To</b>	<b>Press the</b>
select a folder to clear	<b>OK</b> key up or down. To delete all of your items, select <b>All</b> .
place or remove a check mark	<b>OK</b> or <b>i</b> key.

2. To delete the marked items, press the **Delete** soft key.

3. When a confirmation message displays, press the **Yes** soft key to confirm.
4. When the display asks for confirmation again, press the **Yes** soft key.

## **Memory status** *(Menu 6.6)*

---

You can check the amount of the memory being used and the memory remaining for games or sounds, images, and videos separately.





# Organiser

The Organiser feature enables you to:

- view the calendar and organise your schedule.
- define a list of things to do.
- set an alarm so that the phone rings at a specific time, for example to remind you of an appointment.
- use the phone as a calculator for basic mathematical equations or currency exchange operations.

## **Alarm** *(Menu 7.1)*

---

This feature allows you to:

- set the alarm to ring at a specific time.
- set the phone to switch on automatically and ring the alarm even if the phone is switched off.

The following options are available:

**Once:** the alarm rings only once and is then deactivated.

**Daily:** the alarm rings every day at the same time.

**Morning call:** the alarm rings to wake you up in the morning.

To set an alarm:

1. Choose the type of alarm to be set and press the **Select** soft key.
2. Enter the time for the alarm to sound.

**Note:** Your phone is preset to use a 24-hour format. To change the format, see page 142.



If you want to use the alarm options, press the **Options** soft key. The following options are available:

- **Remove alarm:** deactivates the current alarm.
- **Alarm sound set:** allows you to select the alarm melody.

3. Press the **OK** or **i** key.
4. If applicable, select **AM** or **PM** and press the **Select** soft key.
5. If you select **Morning call** in step 1, choose the repeat option, **Monday to friday** or **Monday to saturday**, and press the **Select** soft key.

To stop the alarm when it rings, press either of the Volume keys or press the **Exit** soft key.

**Remove:** deactivates all alarm settings.

**Autopower:** when this option is set to **Enable**, the alarm rings at the specified time, even if the phone is switched off.

If the option is set to **Disable** and the phone is switched off at the specified time, the alarm does not ring.

## Calendar *(Menu 7.2)*

---

With the Calendar feature, you can:

- consult the calendar and check your memos.
- write memos to keep track of your schedule.
- set an alarm to act as a reminder.

### Consulting the calendar

When you select the **Calendar** menu, the calendar displays with today's date highlighted. The following options are available when you press the **Options** soft key:

**Search all:** displays all of the memos, starting with the oldest regardless of the day. To scroll through the memos, press the **OK** key up or down.

**Delete all:** allows you to delete all of the memos. You are asked to confirm your action.

**Go to date:** allows you to go to a specific date.

**Exit:** exits the Calendar feature and returns to Idle mode.

### Writing a memo

You can make up to 30 memos for one day.

To write or edit a memo on a specific date:

1. Select a date on the calendar by pressing the **OK** key to each direction.

**Note:** To skip to the previous or next month, press the Volume keys on the left side of the phone.

2. Press the **OK** or **i** key.

An empty memo screen displays allowing you to enter your memo.

3. Enter your memo and then press the **OK** soft key.

**Note:** For further details about how to enter characters, see page 36.

You are asked if you wish to set an alarm.

4. If you want an alarm to ring on the chosen day, press the **OK** or **i** key. Continue to the next step.

Otherwise, press the **Skip** soft key. The memo is saved.

5. Enter the time for the alarm and press the **OK** or **i** key.

**Note:** Your phone is preset to use a 24-hour format. To change the format, see page 142.

You can also select the melody for the alarm by pressing the **Melody** soft key.

6. If applicable, select **AM** or **PM** and press the **Select** soft key.

The colour of the date on the calendar changes to green to indicate that a memo exists for that date.

When the alarm time for a memo comes and the phone sounds the selected alarm melody, press the **View** soft key to review the memo. Alternatively, press the **Exit** soft key to stop the alarm.

## Organiser

### Viewing a memo

When you select a day on which more than one memo exists, the latest memo for that day displays.

In that case, press the **OK** key up or down to scroll to the previous or next memo.

You can access the following options by pressing the **Options** soft key:

**New:** allows you to add a new memo for the day.

**Edit:** allows you to change the memo text.

**Alarm:** allows you to set an alarm to ring at a specified time to remind you of the memo. If you have already set an alarm for that memo earlier, you can change or delete the alarm.

**Delete:** allows you to delete the memo.

**Copy to:** allows you to copy the memo to another date.

**Move to:** allows you to change the date of the memo.

**Send via IrDA:** allows you to send the memo to another phone via the infrared port.

### To do list *(Menu 7.3)*

---

This feature allows you to:



- enter a list of tasks to be done.
- assign a priority and a deadline to each task.
- sort the tasks by priority and status.



## Creating the To do list

1. Press the **New** soft key.
2. Enter the first task.  
**Note:** For further details about how to enter characters, see page 36.
3. Press the **OK** soft key.
4. Select a priority level of high, normal or low priority by pressing the **OK** key up or down and press the **Select** soft key.
5. Enter your deadline and press the **OK** or **i** key.  
If you do not want to set a deadline, press the **Skip** soft key.

## Editing the To do list

When you select the **To do list** menu (**Menu 7.3**), the current contents display with a check mark, indicating whether a task has been done, and its priority level;  for High,  for Normal, and  for Low.

Scroll to the task you want to view and press the **OK** or **i** key. The details of the task display. You can scroll through the task contents by pressing the **OK** key up or down, if necessary.

To change the status of a specific task as completed as of the current time and date, press the **\*** key.

By pressing the **Options** soft key, you can access the following options:

**New:** allows you to create a new task.

## Organiser

**Mark:** allows you to mark the task as completed as of the current time and date.

**Edit:** allows you to change the text, priority and/or deadline for the task.

**Sort:** allows you to sort the existing tasks by priority or status. Select a sort criterion (**High**, **Low**, **Done**, or **Undo**).

**Copy:** allows you to copy a task.

**Copy to calendar:** allows you to copy a task to the calendar as a memo.

**Delete:** deletes the task.

**Delete all:** allows you to delete all of tasks.

**Exit:** exits the To do list.

## Calculator *(Menu 7.4)*

---

With this feature, you can use the phone as a calculator. The calculator provides basic arithmetic functions: addition, subtraction, multiplication, and division.

1. Enter the first number using the numeric keys.

**Notes:**

- To move the cursor left or right, press the **✕** or **#** keys.
- To include a decimal point or a bracket, press the left soft key until the symbol you want displays.

2. Enter the operation for your calculation by pressing the **OK** key to each direction, according to the image on the display.

3. Enter the second number.
4. To view the result, press the **OK** or **i** key.
5. Repeat steps 1 to 4 as many times as required.

## **Currency converter** *(Menu 7.5)*

---

Using this menu, you can figure out currency conversions.

1. Enter the current exchange rate of your source currency and press the **OK** soft key.

You can insert a decimal point by pressing the **#** key.

2. Enter the amount to convert and press the **OK** soft key.

The amount you entered and its equivalent value display.

3. Press the **Exit** soft key to exit the currency converter.





# Camera

Using the camera module embedded in your phone, you can take photos of people or events while on the move. You can also send photos to other people in a multimedia message or set one as wallpaper or a caller ID image for a Phonebook entry.

You can also record videos using the phone as a camcorder.

**Note:** You can quickly access the **Camera** menu by pressing the Camera key (  ) in Idle mode.

## **CAUTION:**

- Do not take photos of people without their permission.
- Do not take photos in a place where cameras are not allowed.
- Do not take photos in a place where you may interfere with another person's privacy.

## **Taking a photo**

---

The camera produces JPEG photos. You can take a photo with the phone open or closed. When the phone is closed, you can use the external display.

**Note:** When you take a photo in direct sunlight or in bright conditions, shadows may appear on the photo.



### **Taking a photo with the phone open**

1. In Idle mode, press and hold the Camera key (  ).

The image to be captured appears on the display.

2. Adjust the image by rotating the camera and aiming it at the subject.
  - Press the left soft key to use the camera options. For details, see below.
  - You can use the keypad to adjust the image settings. For details, see page 131.
3. Press the Camera key, the **OK** key, or the **z** key to take the photo.
4. Press the **Save** soft key.

To discard the photo and return to Capture mode, press the **Cancel** soft key.

5. To	Press the
use the photo options	<b>Options</b> soft key. For further details, see page 136.
return to Capture mode	 soft key or the <b>C</b> key.
return to Idle mode	 key.

### Using the camera options in Capture mode

In Capture mode, you can assess various options by pressing the left soft key.

The following options are available:

**Mode:** allows you to take a photo in various mode. Once you change the mode, its indicator appears at the top left of the display.

Normal shot: allows you take a photo in the normal mode.

## Camera

Multi shot: allows you to take a series of action stills. Select the number of photos the camera will take. When you press the Camera key, the camera takes photos successively.

After taking photos, press the **Select** soft key to select the photo(s) you want to save and press the **Save** soft key.

Matrix shot: allows you to take several stills and save them in one frame. It will save as one image consisting of the multiple stills taken. Select the number of photos you will take.

**Effects**: allows you to change the colour tone or apply a special effect to the photo.

**Frames**: allows you to use a decorated frame. Select a frame from the list using the **OK** key.

**Timer**: allows you to set a time delay before the camera takes a photo. Select the length of delay you want.

**Settings**: allows you to change the default settings for taking a photo.

Size: allows you to select the image size.

Quality: allows you to select the image quality.

Shutter sound: allows you to select a sound when you press the shutter, the Camera key.

Default name: allows you to change the prefix of the default photo name.

**Go to my album**: allows you to view the photos you took in the **My album** menu (**Menu 8.3**). See page 136.

**Help**: shows you the functions of the keys you can use.

## Using the keypad in Capture mode

You can use the following keys to adjust the image to be captured:

Key	Function
<b>OK</b> (left or right)	adjusts the image brightness.
<b>OK</b> (up or down)	zooms in or out.
↑	flips the image vertically.
↓	shows the mirror image.
<b>1</b>	switches to Record mode. See page 133.
<b>2</b>	changes the image size.
<b>3</b>	changes the image quality.
<b>4</b>	switches the camera shot mode.
<b>5</b>	applies a special effect to the image or changes the colour tone.
<b>6</b>	clears white lines which may occur on the image when you use the camera in direct sunlight.
<b>7</b>	uses a decorated frame with the image.
<b>8</b>	sets a time delay before taking a photo.
<b>9</b>	goes to the <b>My album</b> menu. See page 136.
<b>0</b>	changes the frame size.



## Camera

### Using the camera with the phone closed

1. To turn the camera on, press and hold the Camera key for more than 3 seconds.  
The image to be captured appears on the external display.
2. Adjust the image by rotating the camera and aiming it at the subject.
  - Press the **OK** key left or right to adjust the image brightness.
  - Press the **OK** key to up or down to zoom in or out.
  - Press the Volume keys to flip the image vertically.
3. Press the Camera key or the **OK** key.  
The phone automatically saves the photo and then returns to Capture mode.

### **Photos** *(Menu 8.1)*

---

When you select this menu, the camera turns on and you can take a photo.

For details about taking a photo, see page 128.



## Videos *(Menu 8.2)*

---

You can record a video that is currently displayed on the camera screen and save it as an MPEG file.

1. When the camera turns on, adjust the image by aiming the camera at the subject.
  - Press the left soft key to use the camera options. For details, see below.
  - You can use the keypad to adjust the image settings. For details, see page 135.
2. Press the Camera key, the **OK** key, or the **i** key to start recording.
3. When you are finished, press the Camera key, the **OK** key, or the **i** key.
4. Press the **Save** soft key.

To discard the photo and return to Record mode, press the **Cancel** soft key.

5. To	Press the
use the video options	<b>Options</b> soft key. For further details, see page 137.
return to Record mode	 soft key or the <b>C</b> key.
return to Idle mode	 /⓪ key.

## Camera

### Using the camera options in Record mode

When you press the left soft key in Record mode, you can use the following options for recording a video:

**Mode:** allows you to select the maximum recording time for the video, depending on its purpose. Select **MMS** to record a video for adding to an MMS message. You can record a video of up to 95KBytes.

**Effects:** allows you to change the colour tone or apply special effects to the video.

**Timer:** allows you to set a time delay before the camera starts recording the video. Select the length of delay you want.

**Settings:** allows you to change the default settings for recording a video.

Size: allows you to select the image size.

Quality: allows you to change the image quality.

Audio: allows you to record audio with the video.

Default name: allows you to change the prefix of the default video name.

**Go to my album:** switches to the **My album** menu (**Menu 8.3**). See page 136.

**Help:** shows you the functions of the keys you can use.

## Using the keypad in Record mode

You can use the following keys to adjust the image to be captured:

Key	Function
<b>OK</b> (left or right)	adjusts the image brightness.
<b>OK</b> (up or down)	zooms in or out.
↑	flips the image vertically.
↓	shows the mirror image.
<b>1</b>	switches to Capture mode. See page 128.
<b>2</b>	changes the image size.
<b>3</b>	changes the image quality.
<b>4</b>	switches the record mode.
<b>5</b>	applies a special effect to the image or changes the colour tone.
<b>6</b>	clears white lines which may occur on the image when you use the camera in direct sunlight.
<b>7</b>	turns on or off audio.
<b>8</b>	sets a time delay before recording a video.
<b>9</b>	goes to the <b>My album</b> menu. See page 136.
<b>0</b>	changes the frame size.



## Camera

### **My album** *(Menu 8.3)*

---

In this menu, you can review your photos and videos.

#### **Photo album** *(Menu 8.3.1)*

This menu allows you to review your photos. When you access this menu, your phone displays them in Thumbnail mode, which shows photos as small images.

Scroll through the photos by pressing the **OK** key to each direction. The  icon indicates that it contains the photos taken in Multi-shot mode. The number in the icon shows the number of the photos in the current image folder.

To view an image on the full screen, press the **View** soft key. In this mode, you can scroll through the photos by pressing the **OK** key left or right.

Press the **Options** soft key to use the following options:

**View mode:** allows you to change the default view mode to **List** or **Thumbnail**.

**Send:** allows you to send the photo to other people as a part of a multimedia message. For further details, see page 99. You can also move it to an optional memory card.

**Set as:** allows you to set the image as your wallpaper for the idle screen or a caller ID image for a Phonebook entry.

**Rename:** allows you to change the name of the photo.

**Delete:** deletes the photo.

**Protection:** allows you to protect the photo from being deleted.

**Properties:** shows the properties of the photo, such as the file name, file size, the time and date it was saved, resolution and protection status.

**Go to photos:** switches to Capture mode.

**Go to videos:** switches to Record mode.

### Video album *(Menu 8.3.2)*

When you access this menu, the thumbnail images of the videos display. The  icon on an image indicates that the video is saved for using as a part of an MMS message. To view an image on the full screen, press the **View** soft key.

To play a video:

1. Press the **OK** key to each direction to scroll to the video you want to view.
2. Press the **OK** or **i** key to start playing the video.

3. To	Press the
pause playing and then resume	<b>OK</b> key.
skip forward	<b>OK</b> key right.
move backward	<b>OK</b> key left.
mute the sound	left soft key.
stop	right soft key.
return to the video list	<b>C</b> key.

## Camera

Press the **Options** soft key on the video list to use the following options:

**View mode:** allows you to change the view mode to **List** or **Thumbnail**.

**Rename:** allows you to change the file name.

**Send:** allows you to send the video to other people as a part of a multimedia message. For further details, see page 99. You can also move it to an optional memory card.

**Set as wallpaper:** allows you to set the image as your wallpaper for the idle screen.

**Delete:** deletes the current video file.

**Protection:** allows you to protect the video from being deleted.

**Properties:** show the properties of the video file, such as the file name, size, the time and date it was saved, resolution, quality and protection status.

**Go to photos:** switches to Capture mode.

**Go to videos:** switches to Record mode.

## Delete all *(Menu 8.4)*

---

This menu allows you to delete your photos or videos separately. You can also delete all of them at one time.

1. To	Press the
select an item to clear	<b>OK</b> key up or down. To delete all of contents, select <b>All</b> .
place or remove a check mark	<b>OK</b> or <b>i</b> key.

2. To delete the marked items, press the **Delete** soft key.
3. When the display asks if you want to delete protected file and caller ID images, press the **Yes** soft key to confirm.
4. When the display asks for confirmation again, press the **Yes** soft key.

## Memory status *(Menu 8.5)*

---

You can check the amount of memory being used and the memory remaining in the camera.

The display shows the Total, Used, and Free memory amount for the currently selected memory location. Press the **Next** soft key to view memory space in use for photos, video files, and audio files, individually. At the bottom of the screen is a sliding scale that shows the amount of memory used and available for these features, collectively.

## Camera

### **Select memory location** *(Menu 8.6)*

---

You can change a default memory location to store photos and videos.

Select either **Phone** or **MMC** (memory card).



# Settings

In this menu, you can customise your phone's various settings, such as:

- time and date settings
- phone settings
- display settings
- sound settings
- network services
- security

## **Time & Date** *(Menu 9.1)*

---

This menu allows you to change the current time and date displayed. You can also find out what time it is in another part of the world.

### **Set Time** *(Menu 9.1.1)*

This menu allows you to enter the current time. You can choose the time format in the **Time format** menu (**Menu 9.1.4**).

**Note:** Before setting the time, you must specify your time zone in the **World time** menu (**Menu 9.1.3**). See the following page.

### **Set date** *(Menu 9.1.2)*

This menu allows you to enter the day, month, and year.

## Settings

### **World time** *(Menu 9.1.3)*

This menu allows you to find out what time it is in another part of the world.

The screen shows the:

- city name.
- time difference between the selected city and your city if you have set your local time (see below for further details).
- current time and date.

To select your time zone:

1. Select the city corresponding to your time zone by pressing the **OK** key left or right one or more times.

The local time and date display.

2. Press the **Set** soft key.

### **Time format** *(Menu 9.1.4)*

This menu allows you to change the time format to **12 Hours** or **24 Hours**.

## **Phone settings** *(Menu 9.2)*

---

Many different features of your phone can be customised to suit your preferences. All of these features are accessed in the **Phone settings** menu.

### **Language** *(Menu 9.2.1)*

You can select a display language. When the language option is set to **Automatic**, the language is automatically selected according to the language of the SIM card used.

**Note:** Depending upon your country, service provider, or the software version of the phone, the **Automatic** option may not display.

### **Greeting message** *(Menu 9.2.2)*

This menu allows you to set a greeting to be displayed briefly when the phone is switched on.

For further details about how to enter characters, see page 36.

### **Infrared activate** *(Menu 9.2.3)*

This feature allows you to send or receive data through the infrared port.

#### **With PC**

To use an infrared connection with your computer, you must:

- configure and activate an IrDA-compliant infrared port on the computer.



## Settings

- activate the infrared feature on the phone; the IrDA icon (  ) appears on the top line of the display.
- align the infrared port on the phone with the infrared port on the computer.

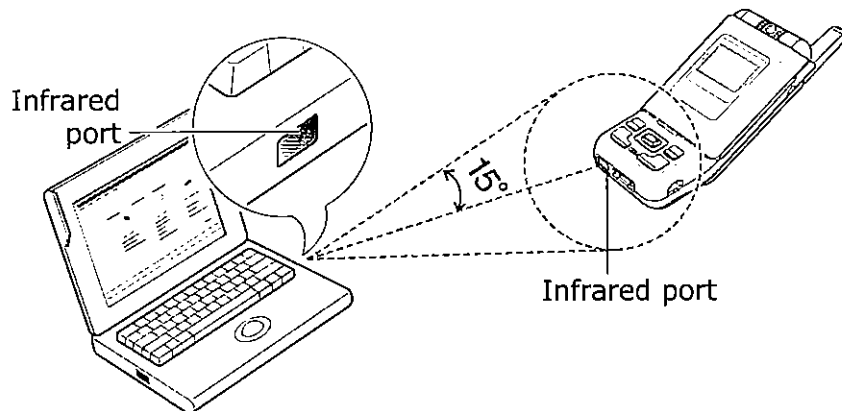

The connection is ready for data transmission.

If there is no communication between your phone and the IrDA-compliant device within 30 seconds of activating the feature, it is automatically deactivated.

**Note:** For optional performance, use the data link cable supplied With your phone.

### With other phone

To receive Phone Book entries and calendar memos from another compliant phone using the infrared connection, you need to activate the infrared port on your phone.

**Note:** If you receive a call while sending or receiving data, you can either answer or reject the call without interrupting the IrDA connection. But, picking up your phone may break the connection between the phones, so use the ear-microphone to answer the call.

## Receiving Data from Another Phone

1. Align the infrared ports on both phones with each other.
2. Activate the infrared feature on the phones. For this phone, access the **Infrared activate** menu (**Menu 9.2.3**) and select **With other phone**.

The connection between the phones is established and your phone receives data from the other phone. You can receive up to 20 items in succession.

3. When the list of the received data displays, you have two options:

To save an individual item:

- ① Select one on the list and press the **Select** soft key.

The display shows the Phone Book entry.

- ② Press the **OK** soft key.
- ③ Press the **Options** soft key.

The following options are available:

- **Discard**: deletes the data.
- **Save**: allows you to save the selected data in your phone's memory.

- ④ Select **Save** and press the **Select** soft key.

To save all of the data:

- ① Press the **Options** soft key.

The following options are available:

- **Save all**: allows you to save all data.
- **Save all vCard**: saves all the Phone Book entries from the received data.



## Settings

- **Save all vCalendar:** saves all the calendar memos from the received data.
- **Discard all:** deletes all of the data.
- **Discard all vCard:** deletes all the Phone Book entries from the received data.
- **Discard all vCalendar:** deletes all the calendar memos from the received data.
- **Exit:** exits the IrDA function. When the phone asks if you want to delete the remaining data, press the **Yes** or **No** soft key.

② Select a save option and press the **Select** soft key.

4. When FDN (Fixed Dial Number) mode is enabled on your phone, enter the PIN2 and press the **OK** soft key.

For further details about the FDN mode, see page 165.

5. Press the **Save** soft key.

The entries are saved.

**Short cut** *(Menu 9.2.4)*

The **OK** key can be used as shortcut keys. In Idle mode, it allows you to access specific menus directly when pressed to each direction.

To assign a shortcut to a key:

1. Select the direction to be used as a shortcut key by pressing the **OK** key up or down and press the **Select** soft key.
2. Select the menu to be assigned by pressing the **OK** key up or down.

**Note:** To deactivate a shortcut key, select the **None** option.

3. Press the **Select** soft key to save the selection.

**Extra settings** *(Menu 9.2.5)*

You can turn the automatic redialling or answering features on or off.

To turn a feature	Press the
on	<b>Mark</b> soft key. A check mark displays in front of the option.
off	<b>Unmark</b> soft key. The check mark no longer displays.

The following options are available:



**Auto redial:** when this option is checked, the phone makes up to ten attempts to redial a phone number after an unsuccessful call.

**Note:** The interval between attempts varies.

## Settings

**Active folder:** when this option is checked, you can simply open the phone to answer a call.

When it is unchecked, you must open the phone and press a key to answer a call, depending on the setting of the **Anykey answer** option.

**Anykey answer:** when this option is checked, you can answer an incoming call by pressing any key, except the  key or the **Reject** soft key. To reject the call, press the  key or the **Reject** soft key.

When this option is unchecked, you must press the  key or **Accept** soft key to answer a call.

## Display settings *(Menu 9.3)*

---

In this menu, you can change various settings for the display or the backlight.

### **Main LCD** *(Menu 9.3.1)*

This menu allows you to change the background image or to change the settings for the text display in Idle mode.

The following options are available:

**Wallpaper List:** you can select a background image to be displayed on the idle screen.

To change the background image:

1. Scroll through the list by pressing the **OK** key up or down.

You have various preset images available. You can also select a blank background or any image downloaded from the WAP browser and optional EasyGPRS programme, or received in messages.

Once you have set a photo as the wallpaper, it is designated as **My photo** on this list.

2. Press the **Select** soft key when the image you want highlights.
3. When the image displays, press the **Select** soft key to display it on the idle screen.

**Text display:** you can specify whether or not the phone displays the time and date on the idle screen.

**Text color:** you can select the colour of the text to be displayed on the idle screen. This option is available only when the text display is enabled.

### **Sub LCD** *(Menu 9.3.2)*

This menu allows you to select an image to be displayed on the external display.

### **Menu style** *(Menu 9.3.3)*

This menu allows you to select the menu display style. You can choose one from **Grid style**, **Bar style**, or **Page style**.

## Settings

### **Back light** *(Menu 9.3.4)*

You can select the length of time the backlight is on. The backlight turns on when you press a key, when you open the phone, or when you receive a call or message, and remains on for the specified length of time.

### **Service light** *(Menu 9.3.5)*

This menu allows you to select whether or not the service light is used.

**Off:** the service light flashes only when the phone is switched on or off.

**On:** the service light flashes when the phone is switched on or off and blinks at an interval when service is available.

### **Graphic logo** *(Menu 9.3.6)*

This menu allows you to display your service provider's logo instead of its name.

**Off:** the service provider's name displays in Idle mode.

**On:** the service provider's logo stored in your phone displays in Idle mode; if no logo has been stored, the service provider's name displays.

## **Sound settings** *(Menu 9.4)*

---

You can customise various sound settings.

**Note:** When the phone is in Silent mode (see page 33), you cannot change the sound settings.

### **Ring tone** *(Menu 9.4.1)*

This menu allows you to select a ring melody.

You can choose between many different melodies. If you have downloaded sounds from the WAP browser or the optional EasyGPRS programme, you can access them in this menu.

### **Ring volume** *(Menu 9.4.2)*

This menu allows you to adjust the ring volume to one of five levels.

Press the **OK** key up and down or the Volume keys on the left side of the phone to increase or decrease the volume.

### **Alert type** *(Menu 9.4.3)*

This menu allows you to specify how you are to be informed of incoming calls or alarms you set.

The following options are available:

**Light only:** the service light flashes; the phone neither rings nor vibrates.

**Melody:** the phone rings using the selected ring tone or alarm melody.



## Settings

**Vibration:** the phone vibrates but does not ring.

**Vibra+Melody:** the phone first vibrates three times and then starts ringing.

### **Keypad tone** *(Menu 9.4.4)*

This menu allows you to select the tone that the phone sounds when you press a key.

To turn the sound off, select **Off**.

### **Message tone** *(Menu 9.4.5)*

This menu allows you to select how the phone informs you that a new message has been received.

For each message type, the following options are available:

**Tone:** allows you to select a message tone.

**Mode:** allows you to select an alert type.

Off: the phone does not alerts you.

Tone: the phone uses the message tone selected in the **Tone** option.

Vibration: the phone vibrates.

Light only: the service light flashes.

**Repetition:** allows you to set how often the phone informs you of a new message, **Once** or **Periodic**.

### **Folder tone** *(Menu 9.4.6)*

This menu allows you to select the tone that the phone sounds when you open or close the phone.

To turn the sound off, select **Off**.

### **Power on/off** *(Menu 9.4.7)*

This menu allows you to select the melody that the phone sounds when it is switched on or off.

To turn the sound off, select **Off**.

### **Alerts on call** *(Menu 9.4.8)*

This menu allows you to choose whether or not the phone informs you when you receive a new message or when the time for an alarm comes during a call.

The following options are available:

**Off:** the phone doesn't actively alert you to incoming messages or alarms. It only displays the corresponding notification.

**On:** the phone alerts you with a beep and displays the corresponding notification.

## Settings

### Extra tones *(Menu 9.4.9)*

You can customise additional tones for the phone.

To turn a given tone	Press the
on	<b>Mark</b> soft key. A check mark displays in front of the option.
off	<b>Unmark</b> soft key. The check mark no longer displays.

The following options are available:

**Error tone:** sets whether or not the phone informs you when a mistake is made.

**Minute minder:** sets whether or not the phone beeps every minute during an outgoing call to keep you informed of the length of your call.

**Connect tone:** sets whether or not your phone beeps when your call is connected to the system.

## **Network services** *(Menu 9.5)*

---

These menu functions are network services. Please contact your service provider to check their availability and then subscribe to them, if you wish.

### **Call diverting** *(Menu 9.5.1)*

This network service enables incoming calls to be rerouted to a number that you specify.

Example: You may wish to divert your business calls to a colleague while you are on holidays.

To set your call diverting options:

1. Select a call diverting option by pressing the **OK** key up or down, and then press the **Select** soft key.

The following options are available:

- **Divert always**: all calls are diverted.
- **Busy**: calls are diverted when you are already on another call.
- **No reply**: calls are diverted when you do not answer the phone.
- **Unreachable**: calls are diverted when you are not in an area covered by your service provider, or when your phone is switched off.
- **Cancel all**: all call diverting options are cancelled.

2. Select the type of calls, voice or data, by pressing the **OK** key up or down, and then press the **Select** soft key.



## Settings

3. If you selected **No reply** in step 1. Select the length of time the network waits before diverting a call, and press the **Select** soft key.

The current status displays. If the option has already been set, the number to which the calls are diverted displays.

4. To	Press the
activate call diverting	<b>Activate</b> soft key. Go to step 5.
change the number to be called	<b>Change</b> soft key. Go to step 5.
deactivate call diverting	<b>Remove</b> soft key.

5. Enter the number to which the calls are to be diverted and press the **OK** soft key.

To enter an international code, press the **0** key until the **+** sign displays.

The phone sends your settings to the network and the network's acknowledgement displays.

### **Call barring** *(Menu 9.5.2)*

The call barring network service allows you to restrict your calls.

To set your call barring options:

1. Select a call barring option by pressing the **OK** key up or down, and then press the **Select** soft key.

The following options are available:

- **All outgoing:** calls cannot be made.
- **International:** international calls cannot be made.
- **International except to home:** when abroad, calls can be made only to numbers within the current country and to your home country, which is the country where your home network provider is located.
- **All incoming:** calls cannot be received.
- **Incoming while abroad:** calls cannot be received when you are using your phone outside of your home service area.
- **Cancel all:** all call barring settings are deactivated; calls can be made and received normally.
- **Change barring password:** you can set and change the call barring password obtained from your service provider.

2. Select the type of calls, voice or data, by pressing the **OK** key up or down, and then press the **Select** soft key.
3. Press the **Activate** soft key to confirm your settings.

## Settings

4. Enter your call barring password supplied by your service provider.

The phone sends your settings to the network and the network's acknowledgement displays.

To deactivate specific call barring settings:

1. Select the call barring option to be deactivated.
2. Select the type of calls to which this option applies.
3. Press the **Deactivate** soft key.
4. Enter your call barring password supplied by your service provider.

The phone sends your settings to the network and the network's acknowledgement displays.

## Call waiting *(Menu 9.5.3)*

This network service informs you when someone is trying to reach you during another call.

You can specify individual call waiting options for voice calls and/or data calls.

To set your call waiting options:

1. Select the type of calls, voice or data, to which you want to apply the call waiting option by pressing the **OK** key up or down, and then press the **Select** soft key.

The screen informs you whether call waiting is activated or deactivated.

2. You can activate or deactivate the call waiting feature as necessary by using the **Activate** or **Deactivate** soft key respectively.

To return to the previous screen, press the **Exit** soft key.

You can also deactivate all call waiting settings by selecting the **Cancel all** option.

### **Network selection** *(Menu 9.5.4)*

The Network Selection feature enables you to automatically or manually select the network used when roaming outside of your home area.

**Note:** You can select a network other than your home network only if there is a valid roaming agreement between the two.

To automatically or manually select the network to be used when roaming:

1. Press the **OK** key up or down until the appropriate option highlights and then press the **OK** soft key.

If you select **Automatic**, you are connected to the first available network when roaming.

If you select **Manual**, go to step 2.

2. Press the **OK** key up or down until the network you want highlights and then press the **OK** soft key.

The phone will scan for that network and you will be connected.



## Settings

### **Caller ID** *(Menu 9.5.5)*

You can prevent your phone number from being displayed on the phone of the person being called.

**Note:** Some networks do not allow the user to change this setting.

The following options are available:

**Default:** the default setting provided by the network is used.

**Hide number:** your number does not display on the other person's phone.

**Send number:** your number is sent each time you make a call.

### **Closed user group (CUG)** *(Menü 9.5.6)*

This network service allows incoming and outgoing calls to be restricted to a selected user group. You can create up to ten user groups.

For details about how to create and use a closed user group, contact your service provider.

Example: A company lends SIM cards to its employees and wants to restrict outgoing calls to members of the same team.

### **Activating a closed user group**

If you select the **Closed user group** menu, you can enter the CUG function. You can access the following options after pressing the **Select** soft key:

**Index list:** lets you list, add or delete CUG index numbers. The list of current CUG indexes appears, if there are indexes stored. Add a new CUG index as advised by your service provider or delete a group.



<b>To</b>	<b>Press the</b>
scroll through the existing CUG indexes	<b>OK</b> key up or down.
add a new CUG index	<b>Options</b> soft key, select the <b>Add</b> option and enter the index.
delete a CUG index	<b>Options</b> soft key and select the <b>Delete</b> option.
activate a CUG index	<b>Options</b> soft key and select the <b>Activate</b> option.

**Outside access:** lets you enable or disable calls to numbers other than those in the Closed User Group. This feature depends on the nature of your CUG subscription. Please check with your service provider.

**Default group:** you may set a default CUG with your service provider. If you have done so, you can enable the **Default group** option on your phone. When making a call, you are given the option of using your default CUG, instead of selecting one from the list.

**Deactivate:** deactivates the CUG function. This menu appears only when the default group is enabled or a CUG index is selected.

## Settings

### **Band selection** *(Menu 9.5.7)*

For the phone to make and receive phone calls, it must register with an available network. Your phone can handle any of the following types of networks:

- Combined GSM 900/1800
- GSM 1900

The country where you purchased your phone determines the default band that it uses. When you travel abroad, you must remember to change to an appropriate band.

1. Press the **OK** key up or down until the appropriate option highlights and press the **OK** soft key.
2. When the display confirms the network band you selected, press the **Yes** soft key.

To cancel the selection, press the **No** soft key.

When you select a new band, your phone automatically searches for all available networks. Your phone registers with a preferred network within the band.

### **Security** *(Menu 9.6)*

---

The Security feature enables you to restrict the use of your phone by others and to restrict the types of calls made.

Various codes and passwords are used to protect the features of your phone. They are described in the following sections. Also see pages 170-173.

### **PIN check** *(Menu 9.6.1)*

When the PIN Check feature is enabled, you must enter your PIN each time you switch the phone on. Consequently, any person who does not have your PIN cannot use your phone without your approval.

**Note:** Before disabling the PIN Check feature, you must enter your PIN.

The following options are available:

**Disable:** the phone connects directly to the network when you switch it on.

**Enable:** you must enter the PIN each time the phone is switched on.

### **Change PIN** *(Menu 9.6.2)*

This feature allows you to change your current PIN to a new one, provided that the PIN Check feature is enabled. You must enter the current PIN before you can specify a new one.

Once you have entered a new PIN, you are asked to confirm it by entering it again.

### **Phone lock** *(Menu 9.6.3)*

When the Phone Lock feature is enabled, the phone is locked and you must enter a 4- to 8-digit phone password each time the phone is switched on.

The password is preset to "00000000" at the factory. To change the phone password, see the **Change password** menu (**Menu 9.6.4**).

Once the correct password has been entered, you can use the phone until you switch it off.

## Settings

The following options are available:

**Disable:** you are not asked to enter the phone password when you switch the phone on.

**Enable:** you are required to enter the phone password when you switch the phone on.

### **Change password** *(Menu 9.6.4)*

The Change Password feature allows you to change your current phone password to a new one. You must enter the current password before you can specify a new one.

The password is preset to "00000000" at the factory. Once you have entered a new password, you are asked to confirm it by entering it again.

### **Privacy** *(Menu 9.6.5)*

Using this menu, you can lock your media contents, such as multimedia messages, photos, videos, voice memos, images and sounds. Once you have locked the contents, you must enter the phone's password to access the associated menus.

1. <b>To</b>	<b>Press the</b>
select an item to lock	<b>OK</b> key up or down. To lock all of the contents, select <b>All</b> .
place or remove a check mark	<b>OK</b> or <b>i</b> key.

2. To lock the marked items, press the **OK** soft key.

3. When the phone asks for the phone password, enter the password and press the **OK** soft key.

**Note:** The password is preset to "00000000" at the factory. To change this password, see page 164.

### **SIM lock** *(Menu 9.6.6)*

When the SIM Lock feature is enabled, your phone only works with the current SIM. You must enter the SIM lock code to use a different SIM card.

Once you have entered the lock code, you are asked to confirm it by entering it again.

To unlock the SIM, you must enter the SIM lock code.

### **FDN mode** *(Menu 9.6.7)*

FDN (Fixed Dial Number) mode, if supported by your SIM card, allows you to restrict your outgoing calls to a limited set of phone numbers.

The following options are available:

**Disable:** you can call any number.

**Enable:** you can only call phone numbers stored in Phonebook. You must enter your PIN2.

**Note:** Not all SIM cards have a PIN2. If your SIM card does not, this menu does not display.

## Settings

### **Change PIN2** *(Menu 9.6.8)*

The Change PIN2 feature allows you to change your current PIN2 to a new one. You must enter the current PIN2 before you can specify a new one.

Once you have entered a new PIN2, you are asked to confirm it by entering it again.

**Note:** Not all SIM cards have a PIN2. If your SIM card does not, this menu does not display.

### **Reset settings** *(Menu 9.7)*

---

You can easily reset your phone to its default settings.

Enter the 4- to 8-digit phone password and press the **OK** soft key.

**Note:** The password is preset to "00000000" at the factory. To change this password, see page 164.



# Solving problems

If you are experiencing problems with your phone, perform the following simple checks, before contacting a service professional. This may save you the time and expense of an unnecessary service call.

## **When you switch your phone on, the following messages may appear:**

### **Insert SIM card**

- Check that the SIM card is correctly installed.

### **Phone locked Enter password**

- The automatic locking function has been enabled. You must enter the phone's password before you can use the phone.

### **Enter PIN**

- You are using your phone for the first time. You must enter the Personal Identification Number (PIN) supplied with the SIM card.
- The PIN Check feature is enabled. Every time the phone is switched on, the PIN has to be entered. To disable this feature, use the **PIN check** menu (**Menu 9.6.1**).

### **Enter PUK**

- The PIN code was entered incorrectly three times in succession and the phone is now blocked. Enter the PUK supplied by your service provider.



## Solving problems

### **“No service,” “Network failure” or “Not done” displays**

- The network connection was lost. You may be in a weak signal area (in a tunnel or surrounded by buildings). Move and try again.
- You are trying to access an option for which you have not taken out a subscription with your service provider. Contact the service provider for further details.

### **You have entered a number but it was not dialed**

- Have you pressed the  key?
- Are you accessing the right cellular network?
- You may have set an outgoing call barring option.

### **Your correspondent cannot reach you**

- Is your phone switched on (the  key pressed for more than one second)?
- Are you accessing the right cellular network?
- You may have set an incoming call barring option.

### **Your correspondent cannot hear you speaking**

- Have you switched off the microphone?
- Are you holding the phone close enough to your mouth? The microphone is located at the bottom of the phone.

**The phone starts beeping and  
“\*\*Warning\*\* Low battery” flashes on  
the display**

- Your battery is insufficiently charged. Recharge the battery.

**The audio quality of the call is poor**

- Check the signal strength indicator on the display (📶); the number of bars indicates the signal strength from strong (📶) to weak (📶).
- Try moving the phone slightly or moving closer to a window if you are in a building.

**No number is dialed when you recall a  
Phonebook entry**

- Check that the number has been stored correctly, by using the Phonebook Search feature.
- Re-store the number, if necessary.

If the above guidelines do not help you to solve the problem, take note of:

- the model and serial numbers of your phone
- your warranty details
- a clear description of the problem

Then contact your local dealer or Samsung after-sales service.



# Access codes

There are several access codes that are used by your phone and its SIM card. These codes help you protect the phone against unauthorised use.

When requested for any of the codes explained below, enter the appropriate code (displayed as asterisks) and press the **OK** soft key. If you make a mistake, press the **C** key one or more times until the incorrect digit is cleared and then continue entering the correct code.

The access codes, except for the PUK and PUK2 codes, can be changed using the **Security** menu (**Menu 9.6**). See page 162 for further details.

**Important!** Avoid using access codes resembling emergency numbers, such as 112, so that you do not accidentally dial an emergency number.

## Phone password

---

The Phone Lock feature uses the phone password to protect your phone against unauthorised use. The phone password is supplied with the phone and is preset to "00000000" at the factory.

To	See
activate/deactivate the Phone Lock feature	page 163 ( <b>Menu 9.6.3</b> ).
change the phone password	page 164 ( <b>Menu 9.6.4</b> ).

## PIN

---

The **P**ersonal **I**dentification **N**umber or PIN (4 to 8 digits) protects your SIM card against unauthorised use. It is usually supplied with the SIM card.

If you enter an incorrect PIN three times in succession, the code is disabled and cannot be used until you re-enable it by entering the PUK (see below).

To	See
activate/deactivate the PIN Check feature	page 163 ( <b>Menu 9.6.1</b> ).
change the PIN	page 163 ( <b>Menu 9.6.2</b> ).

## PUK

---

The 8-digit PUK (**P**IN **U**nblocking **K**ey) is required to change a disabled PIN. The PUK may be supplied with the SIM card. If not, or if you have lost it, contact your service provider.

To re-enable your PIN:

1. Enter the PUK and press the **OK** soft key.
2. Enter a new PIN of your choice and press the **OK** soft key.
3. When the **Confirm New PIN** message displays, enter the same code again and press the **OK** soft key.

If you enter an incorrect PUK ten times in succession, the SIM card becomes invalid. Contact your service provider for a new card.

## **PIN2**

---

The PIN2 (4 to 8 digits), supplied with some SIM cards, is required to access specific functions, such as setting the maximum cost of a call. These functions are available if supported by your SIM card.

If you enter an incorrect PIN2 three times in succession, the code is disabled and you cannot access the functions until you re-enable it by entering the PUK2.

To change the PIN2, see page 166 (**Menu 9.6.8**).

## **PUK2**

---

The 8-digit PUK2 (**PIN Unblocking Key 2**), supplied with some SIM cards, is required to change a disabled PIN2. If you lose the code, contact your service provider.

To re-enable your PIN2:

1. Enter the PUK2 and press the **OK** soft key.
2. Enter a new PIN2 of your choice and press the **OK** soft key.
3. When the **Confirm PIN2** message displays, enter the same code again and press the **OK** soft key.

If you enter an incorrect PUK2 ten times in succession, you will not be able to access the functions requiring the PIN2. Contact your service provider for a new card.

## **Barring password**

---

A 4-digit barring password is required when you use the Call Barring function. You can obtain the password from your service provider when you subscribe to this function.

You can change this password in the **Call Barring** menu (**Menu 9.5.2**). See page 157 for further details.



# Health and Safety Information

## Exposure to Radio Frequency (RF) Signals

---

Your wireless phone is a radio transmitter and receiver. It is designed and manufactured not to exceed the emission limits for exposure to radio frequency (RF) energy set by the Federal Communications Commission (FCC) of the U.S. Government. These limits are part of comprehensive guidelines and establish permitted levels of RF energy for the general population. The guidelines are based on the safety standards previously set by both U.S. and international standards bodies:

- American National Standards Institute (ANSI) IEEE. C95.1-1992
- National Council on Radiation Protection and Measurement (NCRP). Report 86. 1986
- International Commission on Non-Ionizing Radiation Protection (ICNIRP) 1996
- Ministry of Health (Canada), Safety Code 6.

The standards include a substantial safety margin designed to assure the safety of all persons, regardless of age and health.

The exposure standard for wireless phones employs a unit of measurement known as Specific Absorption Rate (SAR). The SAR limit recommended by the FCC is 1.6W/kg . \*

---

\* In the U.S. and Canada, the SAR limit for mobile phones used by the public is 1.6 watts/kg (W/kg) averaged over one gram of tissue. The standard incorporates a substantial margin of safety to give additional protection for the public and to account for any variations in measurements.



## Health and Safety Information

SAR tests are conducted using standard operating positions specified by the FCC with the phone transmitting at its highest certified power level in all tested frequency bands. Although the SAR is determined at the highest certified power level, the actual SAR level of the phone while operating can be well below the maximum value. This is because the phone is designed to operate at multiple power levels so as to use only the power required to reach the network. In general, the closer you are to a wireless base station antenna, the lower the power output of the phone.

Before a phone model is available for sale to the public, it must be tested and certified to the FCC that it does not exceed the limit established by the government-adopted requirement for safe exposure. The tests are performed in positions and locations (e.g., at the ear and worn on the body) as required by the FCC for each model. The highest SAR value for this model phone when tested for use at the ear is 1.13 W/Kg and when worn on the body, as described in this user guide, is 0.329 W/Kg (Body-worn measurements differ among phone models, depending upon available accessories and FCC requirements). While there may be differences between the SAR levels of various phones and at various positions, they all meet the government requirement for safe exposure.

The FCC has granted an Equipment Authorization for this model phone with all reported SAR levels evaluated as in compliance with the FCC RF emission guidelines. SAR information on this model phone is on file with the FCC and can be found under the Display Grant section of <http://www.fcc.gov/oet/fccid> after searching on FCC ID A3LSGHX910.



To maintain compliance with FCC RF exposure requirements, use only belt-clips, holsters or similar accessories that maintain a 1.5 cm. separation distance between the user's body and the back of the phone, including the antenna. The use of belt-clips, holsters and similar accessories should not contain metallic components. The use of accessories that do not satisfy these requirements may not comply with FCC RF exposure requirements and should be avoided.

For additional information concerning exposure to radio frequency signals, see the following websites:

**Federal Communications Commission (FCC)**

RF Safety program (select "Information on Human Exposure to RF Fields from Cellular and PCS Radio Transmitters"):

<http://www.fcc.gov/oet/rfsafety>

**Cellular Telecommunications Industry Association (CTIA):** <http://www.wow-com.com>

**World Health Organization (WHO)**

International Commission on Non-Ionizing Radiation Protection (select Qs & As):

<http://www.who.int/emf>

**United Kingdom, National Radiological Protection Board:** <http://www.nrpb.org.uk>

**U.S. Food and Drug Administration (FDA)**

Center for Devices and Radiological Health:

<http://www.fda.gov/cdrh/consumer/>

## **Precautions when using batteries**

---

- Never use any charger or battery that is damaged in any way.
- Use the battery only for its intended purpose.
- If you use the phone near the network's base station, it uses less power; talk and standby time are greatly affected by the signal strength on the cellular network and the parameters set by the network operator.
- Battery charging time depends on the remaining battery charge, the type of battery and the charger used. The battery can be charged and discharged hundreds of times, but it will gradually wear out. When the operation time (talk time and standby time) is noticeably shorter than normal, it is time to buy a new battery.
- If left unused, a fully charged battery will discharge itself over time.
- Use only Samsung-approved batteries and recharge your battery only with Samsung-approved chargers. When a charger is not in use, disconnect it from the power source. Do not leave the battery connected to a charger for more than a week, since overcharging may shorten its life.
- Extreme temperatures will affect the charging capacity of your battery: it may require cooling or warming first.



## Health and safety information

- Do not leave the battery in hot or cold places, such as in a car in summer or winter conditions, as you will reduce the capacity and lifetime of the battery. Always try to keep the battery at room temperature. A phone with a hot or cold battery may temporarily not work, even when the battery is fully charged. Li-ion batteries are particularly affected by temperatures below 0 °C (32 °F).
- Do not short-circuit the battery. Accidental short-circuiting can occur when a metallic object (coin, clip or pen) causes a direct connection between the + and – terminals of the battery (metal strips on the battery), for example when you carry a spare battery in a pocket or bag. Short-circuiting the terminals may damage the battery or the object causing the short-circuiting.
- Dispose of used batteries in accordance with local regulations. Always recycle. Do not dispose of batteries in a fire.

## **Road safety**

---

Your wireless phone gives you the powerful ability to communicate by voice, almost anywhere, anytime. But an important responsibility accompanies the benefits of wireless phones, one that every user must uphold.

When driving a car, driving is your first responsibility. When using your wireless phone behind the wheel of a car, make sure that you are following the special regulations in a given area or country.

## **Operating environment**

---

Remember to follow any special regulations in force in any area and always switch your off phone whenever it is forbidden to use it, or when it may cause interference or danger.

When connecting the phone or any accessory to another device, read its user's guide for detailed safety instructions. Do not connect incompatible products.

As with other mobile radio transmitting equipment, users are advised that for the satisfactory operation of the equipment and for the safety of personnel, it is recommended that the equipment should only be used in the normal operating position (held to your ear with the antenna pointing over your shoulder).

## Health and safety information

### **Electronic devices**

---

Most modern electronic equipment is shielded from radio frequency (RF) signals. However, certain electronic equipment may not be shielded against the RF signals from your wireless phone. Consult the manufacturer to discuss alternatives.

### **Pacemakers**

Pacemaker manufacturers recommend that a minimum distance of 15 cm (6 inches) be maintained between a wireless phone and a pacemaker to avoid potential interference with the pacemaker. These recommendations are consistent with the independent research and recommendations of Wireless Technology Research.

Persons with pacemakers:

- Should always keep the phone more than 15 cm (6 inches) from their pacemaker when the phone is switched on
- Should not carry the phone in a breast pocket
- Should use the ear opposite the pacemaker to minimise potential interference

If you have any reason to suspect that interference is taking place, switch off your phone immediately.

### **Hearing aids**

Some digital wireless phones may interfere with some hearing aids. In the event of such interference, you may wish to consult your hearing aid manufacturer to discuss alternatives.

### **Other medical devices**

If you use any other personal medical devices, consult the manufacturer of your device to determine if it is adequately shielded from external RF energy. Your physician may be able to assist you in obtaining this information. Switch off your phone in health care facilities when any regulations posted in these areas instruct you to do so. Hospitals or health care facilities may be using equipment that could be sensitive to external RF energy.

### **Vehicles**

RF signals may affect improperly installed or inadequately shielded electronic systems in motor vehicles. Check with the manufacturer or its representative regarding your vehicle.

You should also consult the manufacturer of any equipment that has been added to your vehicle.

### **Posted facilities**

Switch off your phone in any facility where posted notices require you to do so.

## **Potentially explosive environments**

Switch off your phone when in any area with a potentially explosive atmosphere and obey all signs and instructions. Sparks in such areas could cause an explosion or fire resulting in bodily injury or even death.

Users are advised to switch off the phone while at a refuelling point (service station). Users are reminded of the need to observe restrictions on the use of radio equipment in fuel depots (fuel storage and distribution areas), chemical plants or where blasting operations are in progress.

Areas with a potentially explosive atmosphere are often but not always clearly marked. They include the areas below decks on boats, chemical transfer or storage facilities, vehicles using liquefied petroleum gas, such as propane or butane, areas where the air contains chemicals or particles, such as grain, dust or metal powders, and any other area where you would normally be advised to turn off your vehicle engine.

## Emergency calls

---

This phone, like any wireless phone, operates using radio signals, wireless and landline networks as well as user-programmed functions, which cannot guarantee connection in all conditions. Therefore, you should never rely solely on any wireless phone for essential communications (medical emergencies, for example).

Remember, to make or receive any calls the phone must be switched on and in a service area with adequate signal strength. Emergency calls may not be possible on all wireless phone networks or when certain network services and/or phone features are in use. Check with local service providers.

To make an emergency call, proceed as follows:

1. If the phone is not on, switch it on.
2. Key in the emergency number for your present location (for example, 112 or any other official emergency number). Emergency numbers vary by location.
3. Press the  key.

If certain features are in use (call barring, for example), you may first need to deactivate those features before you can make an emergency call. Consult this document and your local cellular service provider.

When making an emergency call, remember to give all the necessary information as accurately as possible. Remember that your phone may be the only means of communication at the scene of an accident; do not cut off the call until given permission to do so.



### **Other important safety information**

- Only qualified personnel should service the phone or install the phone in a vehicle. Faulty installation or service may be dangerous and may invalidate any warranty applicable to the device.
- Check regularly that all wireless phone equipment in your vehicle is mounted and operating properly.
- Do not store or carry flammable liquids, gases or explosive materials in the same compartment as the phone, its parts or accessories.
- For vehicles equipped with an air bag, remember that an air bag inflates with great force. Do not place objects, including both installed or portable wireless equipment in the area over the air bag or in the air bag deployment area. If wireless equipment is improperly installed and the air bag inflates, serious injury could result.
- Switch off your phone before boarding an aircraft. The use of wireless phones in an aircraft may be dangerous to the operation of the aircraft, and is illegal.
- Failure to observe these instructions may lead to the suspension or denial of telephone services to the offender, or legal action, or both.

## Care and maintenance

---

Your phone is a product of superior design and craftsmanship and should be treated with care. The suggestions below will help you fulfill any warranty obligations and allow you to enjoy this product for many years.

- Keep the phone and all its parts and accessories out of the reach of small children.
- Keep the phone dry. Precipitation, humidity, and liquids contain minerals that corrode electronic circuits.
- Do not use the phone with a wet hand. Doing so may cause an electric shock to you or damage to the phone.
- Do not use or store the phone in dusty, dirty areas, as its moving parts may be damaged.
- Do not store the phone in hot areas. High temperatures can shorten the life of electronic devices, damage batteries, and warp or melt certain plastics.
- Do not store the phone in cold areas. When the phone warms up to its normal operating temperature, moisture can form inside the phone, which may damage the phone's electronic circuit boards.
- Do not drop, knock, or shake the phone. Rough handling can break internal circuit boards.
- Do not use harsh chemicals, cleaning solvents or strong detergents to clean the phone. Wipe it with a soft cloth slightly dampened in a mild soap-and-water solution.

## Health and safety information

- Do not paint the phone. Paint can clog the device's moving parts and prevent proper operation.
- Do not put the phone in or on heating devices, such as a microwave oven, a stove, or a radiator. The phone may explode when overheated.
- Use only the supplied or an approved replacement antenna. Unauthorised antennas or modified accessories may damage the phone and violate regulations governing radio devices.
- If the phone, battery, charger or any accessory is not working properly, take it to your nearest qualified service facility. The personnel there will assist you, and if necessary, arrange for service.



# Glossary

To help you understand the main technical terms and abbreviations used in this booklet, and to take full advantage of the features of your mobile phone, here are a few definitions:

## **Active folder**

Ability to answer a call simply by opening the phone.

## **Call barring**

Ability to restrict outgoing and incoming calls.

## **Call diverting**

Ability to reroute calls to another number.

## **Call holding**

Ability to put one call on standby while answering or making another call; you can then switch between the two calls, as required.

## **Call waiting**

Informs you that you have an incoming call when you are engaged on another call.

## **Caller line identification services (Caller ID)**

Services allowing subscribers to view or block the telephone numbers of callers.

## **Glossary**

### **EMS (Enhanced Message Service)**

An adaptation of the Short Message Service (SMS) that allows you to send and receive ring tones and the service provider's logo, as well as combinations of simple media to and from EMS-compliant handsets. Because EMS is based on SMS, it can use SMS centres the same way that SMS does. EMS works on all Global System for Mobile communications (GSM) networks. EMS senders can use text, melodies, photos, sounds, and animations to enhance the expressive power of messages that are limited by the display constraints of mobile devices.

### **GPRS (General Packet Radio Service)**

New non-voice value-added service that allows information to be sent and received across a mobile telephone network. GPRS provides continuous connection to the Internet for mobile phone and computer users. It is based on the Global System for Mobile Communication (GSM) circuit-switched cellular phone connections and the Short Message Service (SMS).

### **GSM (Global System for Mobile communication)**

International standard for cellular communication, guaranteeing compatibility between the various network operators. GSM covers most European countries and many other parts of the world.

### **Java**

Programming language generating applications that can run on all hardware platforms, whether small, medium or large, without modification. It has been promoted for and geared heavily to the Web, both for public Web sites and Intranets. When a Java program runs from a Web page, it is called a *Java applet*. When it is run on a mobile phone or pager, it is called a MIDlet.

### **MMS (Multimedia Message Service)**

A message service for the mobile environment, standardized by the WAP Forum and the 3rd Generation Partnership Program (3GPP). For phone users, MMS is similar to Short Message Service (SMS)-it provides automatic, immediate delivery of user-created content from phone to phone. The message addressing used is primarily phone numbers, thus the traffic goes from phone to phone. MMS also provides support for e-mail addressing, so that messages can be sent by e-mail. In addition to the text content of SMS, MMS messages can contain still images, voice or audio clips, and also video clips and presentation information.

### **Multi-party calling**

Ability to establish a conference call involving up to five additional parties.

### **Phone password**

Security code used to unlock the phone when you have selected the option to lock it automatically each time it switches on.

## **Glossary**

### **PIN (Personal Identification Number)**

Security code that protects the phone against unauthorised use. The PIN is supplied by the service provider with the SIM card. It may be a four to eight-digit number and can be changed, as required.

### **Proxy server**

A proxy server resides between a Web client, such as a web browser, and a real Web server and acts as an intermediary between them. When some people browse a web site, their browser is not actually connecting to the web server. The request from their browser goes to a proxy server, and the proxy server makes the request to the web server.

A proxy server can improve performance for groups of users because it caches the results of all requests for a certain amount of time. If a user requests a web page that it already loaded for another user, it reloads the page instead of forwarding the request to the Web server, which can be a time-consuming operation.

### **PUK (PIN Unblocking Key)**

Security code used to unlock the phone when an incorrect PIN has been entered three times in succession. The eight-digit number is supplied by the service provider with the SIM card.

### **Roaming**

Use of your phone when you are outside your home area (when travelling for example).



### **SDN (Service Dialling Numbers)**

Telephone numbers supplied by your network provider and giving access to special services, such as voice mail, directory inquiries, customer support and emergency services.



### **SIM (Subscriber Identification Module)**

Card containing a chip with all the information required to operate the phone (network and memory information, as well as the subscriber's personal data). The SIM card fits into a small slot on the back of the phone and is protected by the battery.

### **SMS (Short Message Service)**

Network service sending and receiving messages to and from another subscriber without having to speak to the correspondent. The message created or received can be displayed, received, edited or sent.

### **Soft keys**

Two keys marked  and  on the phone, the purpose of which:

- varies according to the function that you are currently using.
- is indicated on the bottom line of the display just above the corresponding key.



## **Glossary**

### **Tri band**

Ability to handle any of the following types of network; GSM 900, GSM 1800, combined GSM 900/1800 and GSM 1900 MHz bands, for greater call success and wider roaming.

Your phone automatically searches for the last network used. If, for any reason, this network is unavailable, your phone will attempt to register with a different network.

### **Voice mail**

Computerised answering service that automatically answers your calls when you are not available, plays a greeting (optionally in your own voice) and records a message.



# Index

## A

- Access codes • 170
- Active folder • 148
- Alarm • 120
- Alert type • 151
- Alerts on call • 153
- Alphabet mode, text input • 40
- Answering
  - call • 30
  - second call • 47
- Anykey answer • 148
- Auto redial • 147

## B

- Background image • 148
- Backlight
  - description • 15
  - time, set • 150
- Band selection • 162
- Barring, calls • 157
- Battery
  - charging • 19
  - installing • 18
  - low indicator • 20
  - precautions • 175
  - removing • 17
- Broadcast messages • 108
- Browser, WAP • 78

## C

- Calculator • 126
- Calendar memos
  - copying • 124
  - deleting • 124
  - viewing • 124
  - writing • 122
- Call costs • 61
- Call records
  - dialled • 58
  - missed • 31, 57
  - received • 58
- Call time • 60

- Caller groups
  - editing • 67
  - searching • 66
- Caller ID • 160
- Calls
  - answering • 30
  - barring • 157
  - diverting • 155
  - ending • 25
  - holding • 42
  - making • 24
  - redialling • 25
  - rejecting • 30
  - waiting • 47, 158

## Camera

- options • 129, 134
  - playing videos • 137
  - taking photos • 128
  - viewing photo • 136
- ## CB (Cell Broadcast) messages
- 108
- Characters, enter • 36
  - Charging battery • 19
  - Closed User Group (CUG) • 160
  - Conference call • 47
  - Connect tone • 154
  - Cost, calls • 61
  - Currency converter • 127

## D

- Date, set • 141
- Deleting
  - calendar memo • 124
  - call record • 57
  - multimedia message • 97, 99
  - phonebook • 63
  - photo • 136
  - text message • 86, 87
  - video • 138
  - voice memo • 76
- Delivery reports, message • 92
- Dialled calls • 58

## Index

Display  
    backlight • 15  
    external • 16  
    icons • 14  
    layout • 13  
    settings • 148  
Diverting, calls • 155  
DNS settings • 112  
DTMF tones, send • 45

## E

Earpiece volume • 29  
Emergency calls • 181  
EMS (Enhanced Message Service) • 85  
Error tone • 154  
External display • 16

## F

FDN (Fixed Dial Number)  
    mode • 165  
Folder tone • 153  
Forwarding  
    multimedia message • 97  
Front LCD • 16  
Funbox • 110

## G

Games • 110  
Graphic logo • 150  
Greeting message • 143

## H

Health and safety • 174  
Holding, call • 42

## I

Icons, description • 14  
Images, downloaded • 117  
Inbox, messages

    multimedia • 95  
    text • 85

Infrared, connect • 143  
International calls • 24  
Internet • 78

## J

Java service • 110

## K

Key volume • 29  
Keypad lock • 23  
Keypad tones  
    selecting • 152  
    sending • 45

Keys

    description • 11  
    location • 10

## L

Language, select • 143  
Last number, redial • 25  
Locking  
    keys • 23  
    media contents • 164  
    phone • 163  
    SIM card • 165  
Low battery indicator • 20

## M

Memory card • 21  
Memory status  
    camera • 139  
    downloaded items • 119  
    multimedia messages • 105  
    phonebook • 70  
    text messages • 94

Menus

    accessing • 50  
    list • 52

Message tone • 152

**Messages**  
     cell broadcast • 108  
     greeting • 143  
     multimedia • 94  
     text • 85  
     voice • 107  
     web • 107  
**MIDlets, launch** • 110  
**Minute minder** • 154  
**Missed calls** • 31, 57  
**MMS (Multimedia Message Service)** • 94  
**Morning call** • 120  
**MP3 player** • 72  
**Multimedia messages**  
     creating/sending • 99  
     deleting • 97, 99  
     editing • 99  
     reading • 95, 98  
     setting • 100  
**Multi-party calls** • 47  
**Muting**  
     all sounds • 33  
     key tones • 45  
     microphone • 44

**N**

**Names**  
     entering • 36  
     searching/dialling • 66  
**Network band, select** • 162  
**Network selection** • 159  
**Network services** • 155  
**Numbers, phone**  
     searching/dialling • 66  
     storing • 64

**O**

**On/off switch, phone** • 22  
**Organiser** • 120  
**Outbox, messages**  
     multimedia • 98  
     text • 87  
**Own number** • 70

**P**

**Password**  
     call barring • 157, 173  
     phone • 164, 170  
**Phone**  
     care and maintenance  
         • 183  
     display • 13  
     icons • 14  
     keys • 11  
     layout • 10  
     locking • 163  
     password • 170  
     resetting • 166  
     unpacking • 9  
**Phonebook**  
     copying • 63  
     deleting • 63, 69  
     editing • 63  
     options • 63  
     searching/dialling • 66  
     speed-dialling • 68  
     storing • 64  
**Photos**  
     deleting • 136  
     taking • 128  
     viewing • 136  
**PIN**  
     changing • 163  
     description • 171  
**PIN2**  
     changing • 166  
     description • 172  
**Power on/off tone** • 153  
**Privacy** • 164  
**Problems, solve** • 167  
**PUK** • 171  
**PUK2** • 172

**R**

**Received calls** • 58  
**Received messages**  
     multimedia • 95  
     text • 85

## Index



- Recording
    - videos • 133
    - voice memos • 75
  - Redialling
    - automatically • 147
    - manually • 25
  - Resetting phone • 166
  - Ring tone • 151
  - Ring type • 151
  - Ring volume • 151
  - Road safety • 177
  - Roaming • 159
- S**
- Safety
    - information • 174
    - precautions • 7
  - Scheduler • 122
  - SDN (Service Dialling Numbers) • 71
  - Searching, phonebook • 66
  - Security, calls • 162
  - Sent messages
    - multimedia • 98
    - text • 87
  - Service light • 16, 150
  - Silent mode • 33
  - SIM card
    - installing • 17
    - locking • 165
  - SMS (Short Message Service)
    - Inbox • 85
    - Outbox • 87
  - Soft keys • 34
  - Sound settings • 151
  - Sounds, downloaded • 117
  - Speed-dial • 68
  - Switching on/off
    - microphone • 44
    - phone • 21
- T**
- T9 mode, text input • 40
  - Tasks, to do list
    - creating • 125
    - editing • 125
- Templates
    - multimedia • 103
    - text • 91
  - Text input mode • 37
  - Text message
    - deleting • 86, 87
    - reading • 85, 87
    - setting • 91
  - Text, enter • 36
  - Time format • 142
  - Time, set • 141
  - To do list • 124
  - Tone
    - connect • 154
    - error • 154
    - folder • 153
    - keypad • 152
    - message • 152
    - minute minder • 154
    - power on/off • 153
    - ring • 151
  - Travel adapter • 19
- U**
- User group • 160
- V**
- Vibration • 152
  - Video
    - deleting • 138
    - playing • 137
  - Voice mail • 107
  - Voice memo
    - deleting • 76
    - playing • 76
    - recording • 75
  - Voicemail server • 108
  - Volume, adjust
    - earpiece • 29
    - keypad tone • 29
    - ring • 151
- W**
- Waiting call • 158
  - Wallpaper • 148







- WAP browser
  - access • 78
  - cache, clear • 84
- World time • 142
- Writing message
  - multimedia • 99
  - text • 88



## SGH-X910 GPRS Telephone Quick reference card

- Access the menu functions
- ① Press the **Menu** soft key.
  - ② Scroll by pressing the **OK** key to each direction through the list of the menus until you reach the menu you want.
  - ③ Press the **Select** soft key.
  - ④ Scroll by pressing the **OK** key up and down through the list of the options until the one you want is selected.
  - ⑤ Press the **Select** soft key.

Each of the two soft keys (  and  ) perform the function indicated by the text above it, on the bottom line of the display.

Switch on/off	Press and hold the  key.
Make a call	<ol style="list-style-type: none"> <li>① Enter the number.</li> <li>② Press the  key.</li> </ol>
End a call	Briefly press the  key.
View missed calls immediately after missing them	<ol style="list-style-type: none"> <li>① Open the phone and press the <b>View soft</b> key.</li> <li>② Scroll by pressing the <b>OK</b> key up and down through the missed calls.</li> <li>③ To return the call, press the  key.</li> </ol>
Answer a call	Open the phone or Press the  key.
Adjust the volume	Press the  or  key on the left side of the phone.





Choose the alert type	<ol style="list-style-type: none"> <li>① Select the <b>Alert type</b> menu (<b>Menu 9.4.3</b>).</li> <li>② Select an option: <ul style="list-style-type: none"> <li>• <b>Light only</b></li> <li>• <b>Melody</b></li> <li>• <b>Vibration</b></li> <li>• <b>Vibra+Melody</b></li> </ul> </li> <li>③ Press the <b>Select</b> soft key.</li> </ol>
Store numbers in Phonebook	<ol style="list-style-type: none"> <li>① Enter the number and press the <b>Save</b> soft key.</li> <li>② Select an icon.</li> <li>③ Press the <b>Select</b> soft key.</li> <li>④ Select a memory.</li> <li>⑤ Press the <b>Select</b> soft key.</li> <li>⑥ Enter the name.</li> <li>⑦ Press the <b>OK</b> soft key.</li> <li>⑧ If necessary, change the location number.</li> <li>⑨ Press the <b>OK</b> soft key.</li> <li>⑩ Press the <b>↶/Ⓜ</b> key to return to Idle mode.</li> </ol>

Search for a number in Phonebook	<ol style="list-style-type: none"> <li>① Press the <b>Phonebook</b> soft key.</li> <li>② Select the <b>Search</b> option.</li> <li>③ Enter the first few letters of the name.</li> <li>④ To scroll through the names, press the <b>OK</b> key up or down.</li> <li>⑤ Press the <b>View</b> soft key.</li> <li>⑥ To scroll through the numbers, press the <b>OK</b> key up or down.</li> <li>⑦ Press the <b>↶</b> key to dial.</li> </ol>
Take a photo	<ul style="list-style-type: none"> <li>• With the phone open <ol style="list-style-type: none"> <li>① In Idle mode, press and hold the Camera key.</li> <li>② Press the Camera key.</li> <li>③ Press the <b>Save</b> soft key.</li> </ol> </li> <li>• With the phone closed <ol style="list-style-type: none"> <li>① Press and hold the Camera key for more than 3 seconds.</li> <li>② Press the Camera key.</li> </ol> </li> </ul>