

Tips for moving & storing your machine

- When moving the machine, do not tilt or turn it upside down. Otherwise, the inside of the machine may be contaminated by toner, which can cause damage to the machine or reduce print quality.
- When moving the machine, make sure at least two people are holding the machine securely.



4. Troubleshooting

This chapter gives helpful information for what to do if you encounter an error.

- **Tips for avoiding paper jams** 78
- **Clearing paper jams** 79
- **Understanding the status LED** 90
- **Understanding display messages** 92



This chapter gives helpful information for what to do if you encounter an error. If your machine has a display screen, check the message on the display screen first to solve the error.

If you cannot find a solution to your problem in this chapter, refer to the **Troubleshooting** chapter in the Advanced Guide (see "Troubleshooting" on page 225).

If you cannot find a solution in the User's Guide or the problem persists, call for service.

Tips for avoiding paper jams

By selecting the correct media types, most paper jams can be avoided. To avoid paper jams, refer to the following guidelines:

- Ensure that the adjustable guides are positioned correctly (see "Tray overview" on page 32).
- Do not remove paper from the tray while your machine is printing.
- Flex, fan, and straighten paper before loading.
- Do not use creased, damp, or highly curled paper.
- Do not mix papers in a tray.
- Use only recommended print media (see "Print media specifications" on page 99).

Clearing paper jams

 To avoid tearing the paper, pull the jammed paper out slowly and gently.

In tray 1

 Illustrations on this user's guide may differ from your machine depending on its options or models. Check your machine type (see "Front view" on page 18).

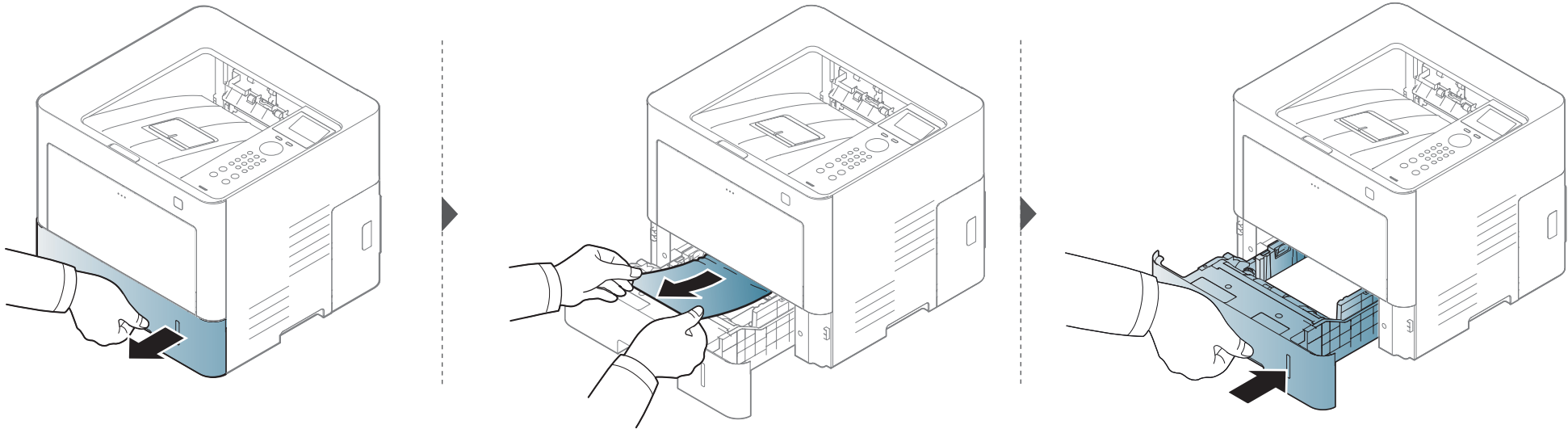

Clearing paper jams

If you do not see the paper in this area, stop and go to next step:

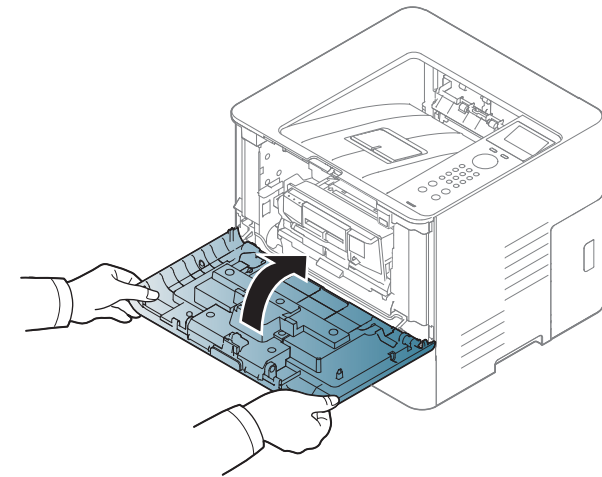
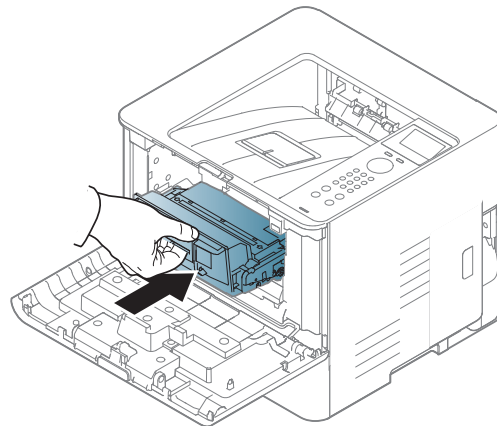
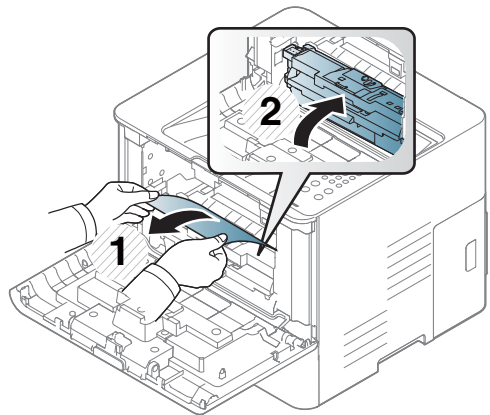
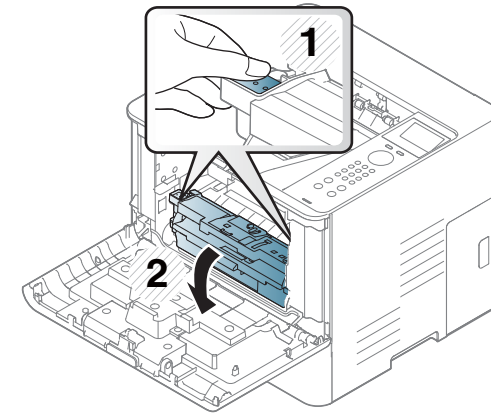
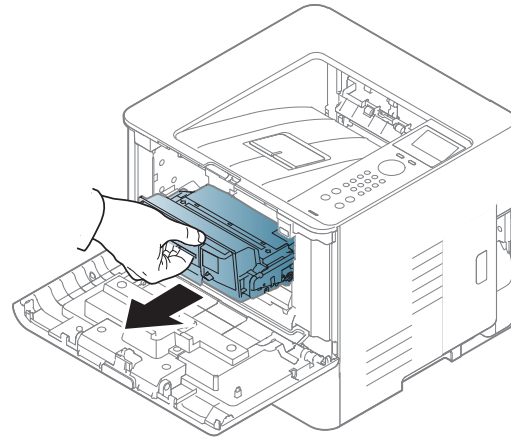
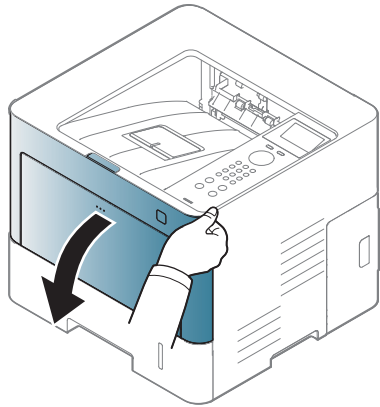

Clearing paper jams

In optional trays



The procedure is same for all optional trays.

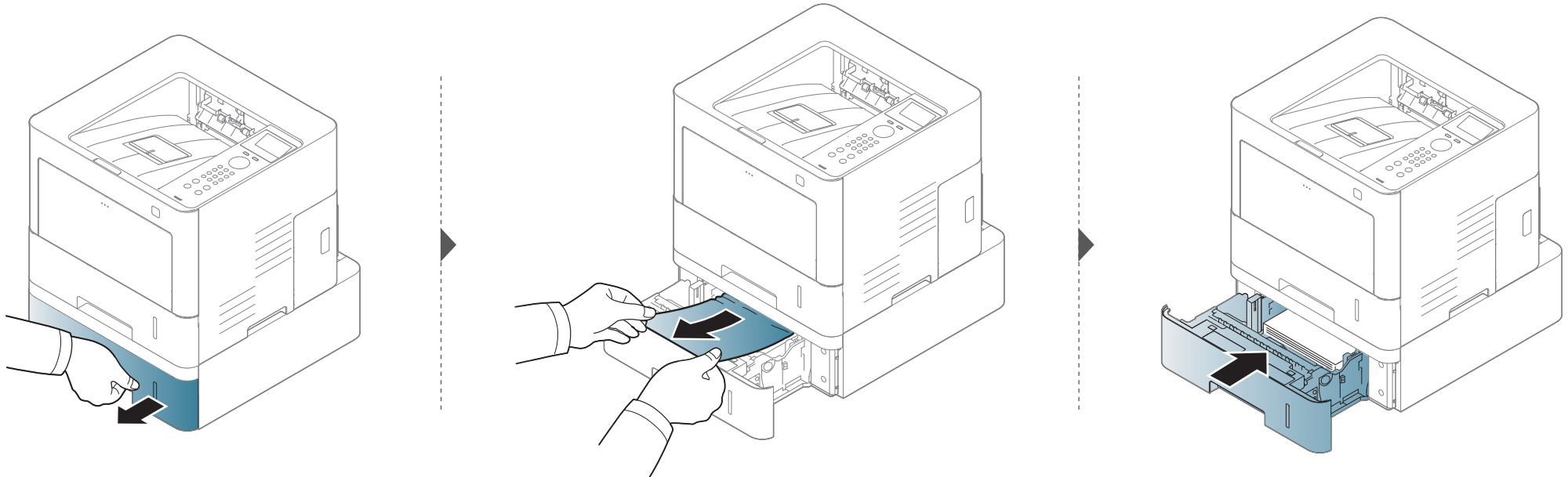

Clearing paper jams

If you do not see the paper in this area, stop and go to next step:

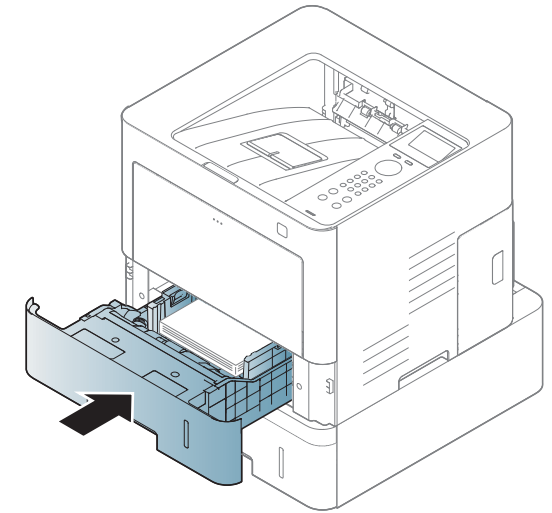
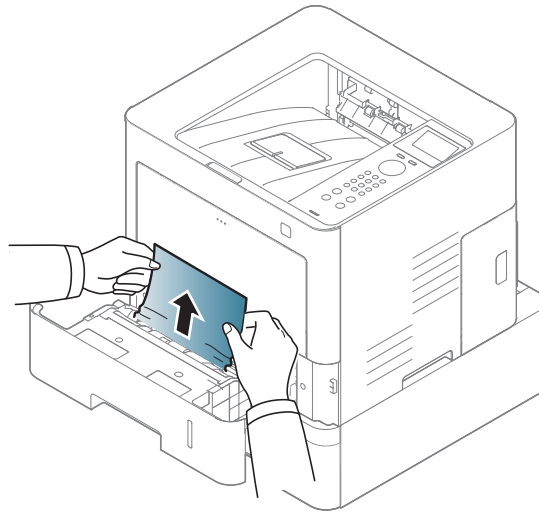
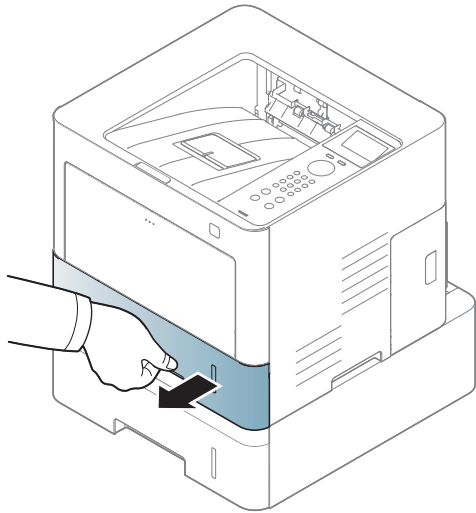

If you do not see the paper in this area, stop and go to next step:

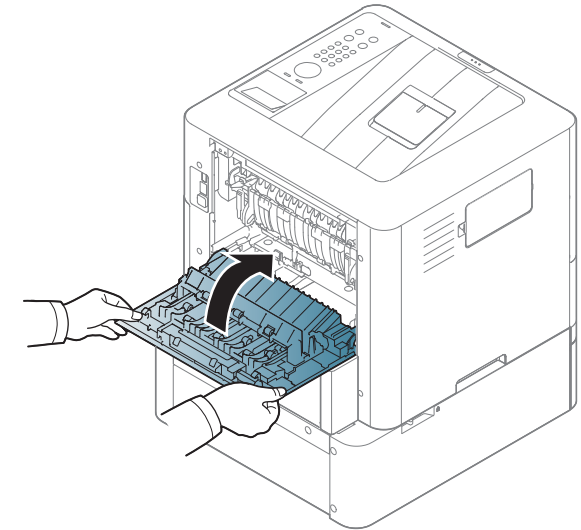
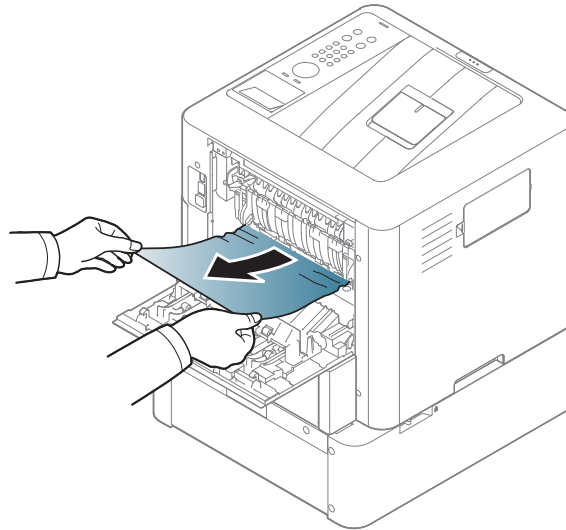
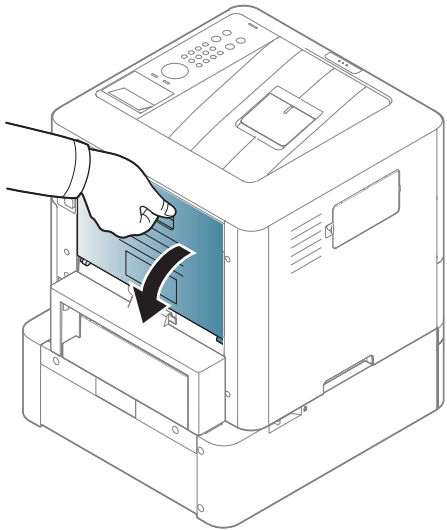

Clearing paper jams

In the multi-purpose tray

