

310 Mobile WiMAX/TD-LTE RRH-2WB

Installation Manual

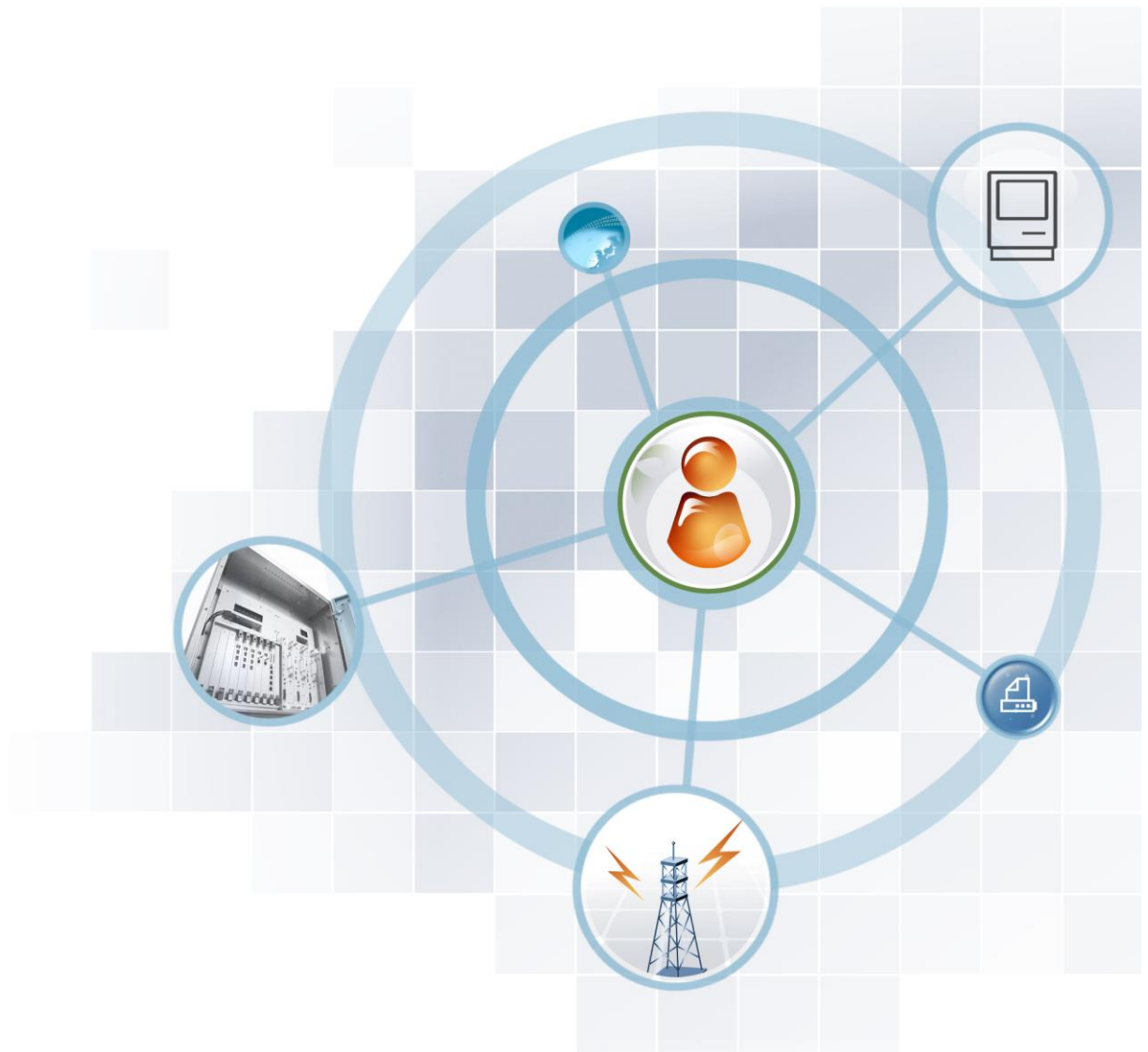

COPYRIGHT

This manual is proprietary to SAMSUNG Electronics Co., Ltd. and is protected by copyright.

No information contained herein may be copied, translated, transcribed or duplicated for any commercial purposes or disclosed to the third party in any form without the prior written consent of SAMSUNG Electronics Co., Ltd.

TRADEMARKS

Product names mentioned in this manual may be trademarks and/or registered trademarks of their respective companies.

This manual should be read and used as a guideline for properly installing and operating the product.

This manual may be changed for the system improvement, standardization and other technical reasons without prior notice.

Updated manuals are available at:

<https://systems.samsungwireless.com/>

For questions on the manuals or their content, contact

NetSysTechWriter@sta.samsung.com

INTRODUCTION

Purpose

This manual describes how to install the RRH-2WB of TD-LTE Flexible system (SLS-BD104) which is a multi-mode BS of Mobile WiMAX/TD-LTE, and how to connect cables.

Document Content and Organization

This document consists of 3 Chapters, 6 Annex and Abbreviation, which are summarized as follows:

CHAPTER 1. Before Installation

This chapter introduces the safety rules that must be understood for installing the RRH-2WB and describes the block diagram of the RRH-2WB.

CHAPTER 2. Installing System

This chapter describes the procedures to install the RRH-2WB.

CHAPTER 3. Connecting Cables

This chapter describes the procedures to connect the cables to the RRH-2WB installed.

ANNEX A. Sector Antenna Installation

This annex describes cautions and installation procedure of the sector antenna.

ANNEX B. Installing Feeder Cable

This annex describes cautions and allowed radius of curvature when installing feeder line.

ANNEX C. Connector Assembly

This annex describes the procedure of assembling connector.

ANNEX D. Cleaning Optic Connector

This annex describes the procedure of cleaning the optic connector and cleaning tool.

ANNEX E. Pressure Terminal Assembly

This annex describes the procedure of assembling the pressure terminal.

ANNEX F. Standard Torque

This annex describes the standard torque when assembling the fixing materials.

ABBREVIATION

Describes the acronyms used in this manual.

Conventions

The following types of paragraphs contain special information that must be carefully read and thoroughly understood. Such information may or may not be enclosed in a rectangular box, separating it from the main text, but is always preceded by an icon and/or a bold title.



WARNING

Provides information or instructions that the reader should follow in order to avoid personal injury or fatality.



CAUTION

Provides information or instructions that the reader should follow in order to avoid a service failure or damage to the system.



CHECKPOINT

Provides the operator with checkpoints for stable system operation.



NOTE

Indicates additional information as a reference.

Revision History

VERSION	DATE OF ISSUE	REMARKS
2.0	06. 2012.	- 'Humidity condition' was changed. (1.2) - 'Table 3.5'~'Table 3.7' were changed. - 'Cable Connection of RET' (3.5.2) was added. - DU configuration was changed. (Figure 3.2, Table 3.7)
1.0	04. 2012.	First Version

SAFETY CONCERNS

The purpose of the Safety Concerns section is to ensure the safety of users and prevent property damage. Please read this document carefully for proper use.

Symbols

**Caution**

Indication of a general caution

**Restriction**

Indication for prohibiting an action for a product

**Instruction**

Indication for commanding a specifically required action

 **WARNING****Power and Grounding****Watches, Rings, and Other Metallic Accessories**

Do not wear accessories such as watches and rings in order to prevent electrical shock.

**Power Switch Off**

Make sure the power switch of power supplier is off when installing the system. Installing the system with power switch on may cause system damage or fatal human injury when cables are not correctly connected.

**Warning for Connecting the Ground Cable**

In cabling, the connection of cables without the connection to the ground cable may cause the damage of the equipment or the injury of the worker.

Connect the ground cable first.

Installation**Warning for Laser Beam Running through Optical Cables**

In the system, the laser beam emitting light runs through the optical cable. The exposure of the laser beam on worker's eye may cause serious injury so that it should be handled with care.

**Protection gloves and goggles**

Make sure that worker wears protection gloves and goggles to prevent damages from debris while drilling holes in a wall or ceiling.



CAUTION

Power and Feeder line



Cautions while Cleaning Power Supply

While cleaning the power supply device, take caution that the device does not come in contact with alien bodies that may cause power failure.



Handling the Power Cable

- Handling the power cable incorrectly may damage the rack or cause an electric shock through the cable. Ensure the power switch on the rectifier or the system is turned off before handling the power cable.
- The fixing materials for power cable must be tightly secured to prevent electrical accidents.



Power cable

In case of using AWG8 (6 mm² × 2C) power cable, it is applicable up to 70 m (299.66 ft). When the distance is 70 m (299.66 ft), followings should be considered.

- Do not rapid ON/OFF (within one second): The voltage loss value caused by the cable resistance loss is 3 V, and the RRH-2WB could be damaged by the counter electromotive force caused by the cable inductance.
- The battery's life could be shorten: The RRH-2WB could be off in spite the battery remains. (When the battery capacity is designed within one hour)
- Do not use the power cables linked: Using the power cables linked each other, the loss will be increased.



Precautions for Measuring Insulation Resistance

Since a high voltage is used for measuring insulation resistance, insulation resistance should not be measured when the system is in operation. Make sure to only measure the insulation resistance of the appointed part. Other components such as the system's internal components and the unit (system frame), components of the communication cables, units, etc. should not be measured.



Cable Work Sequence

When performing cable work for the system, proceed with the ground work before any other work to prevent errors occurring due to static electricity and other reasons.

**Connection of Feeder Cable Connector**

Connecting the feeder cable connector is critical process, so the qualified workers who finished the related education should perform.

**Radius of Curvature of Feeder Line**

When installing a feeder line, the radius of curvature of the sections where cables bent should be larger than the allowed radius of curvature. If the radius of curvature for the feeder line installation is less than the allowed radius of curvature, it may affect the performance of the system.

Installation**Cautions while Cleaning the Rack**

Make sure that worker does not damage installed cables while cleaning the rack.

**System Installation and Access**

Only authorized workers are allowed to install or access the system.

**Do not Work by Yourself**

Worker must not work alone in any key process.

**Management of Unused Ports**

Cover the unused ports (conduit, cable gland, etc.) with waterproof cap (sealing cap) to prevent infiltration of foreign material such as dust, moisture, or bug.

**Caution When Connecting the Optical Cable**

When connecting the optical cable, be careful to keep the cutting section of the connector core away from dust and foreign substances. If the cable is soiled with foreign substances, do not blow on the cable to remove them. Make sure to remove the dust or foreign substances in accordance with the cleaning instructions provided by the connector manufacturer.



Finishing Heat Shrink Tube of a Sector Antenna

- 1) Insert an antenna protection plate to antenna port.
- 2) Place the heat shrink tube on the connection point and shrink the heat shrink tube using a heat gun. Avoid aiming the heating gun toward the antenna's body.



Installing the Antenna

When you install the antenna, the distant and angle between the antenna and lightning rod must be within the protective angle (left/right side 45° each from the central axis) to prevent the antenna from lightning damage.

California USA Only



This Perchlorate warning applies only to primary CR (Manganese Dioxide) Lithium coin cells in the product sold or distributed ONLY in California USA
'Perchlorate Material-special handling may apply, See www.dtsc.ca.gov/hazardouswaste/perchlorate.'

TABLE OF CONTENTS

INTRODUCTION	I
Purpose	I
Document Content and Organization	I
Conventions	II
Revision History	III
SAFETY CONCERNS	IV
Symbols	IV
Warning	V
Caution	VI
California USA Only	VIII
CHAPTER 1. Before Installation	1-1
1.1 System Configuration and Structure	1-1
1.2 Specifications	1-4
1.3 Cautions for Installation	1-6
1.4 Pre-survey	1-8
1.5 Installation Tools	1-9
CHAPTER 2. Installing System	2-1
2.1 Installing the RRH-2WB	2-1
2.2 Foundation Work	2-2
2.2.1 System Arrangement	2-2
2.2.2 Marking and Drilling	2-3
2.3 Unpacking and Transporting	2-4
2.3.1 Importing Items	2-4
2.3.2 Unpacking Items	2-4
2.4 Fixing the System	2-5
2.4.1 Fixing the Wall Type RRH-2WB	2-5
2.4.2 Fixing the Pole Type RRH-2WB	2-8
2.4.3 Fixing the Tower type RRH-2WB	2-22

2.5	System Leveling.....	2-31
2.6	Insulation Test.....	2-33

CHAPTER 3. Connecting Cables **3-1**

3.1	Work Flow for Cabling	3-1
3.2	Cabling.....	3-5
3.3	Grounding.....	3-7
3.3.1	Grounding the System.....	3-8
3.4	Power Construction	3-10
3.4.1	Installing the Power Cable.....	3-10
3.5	External Interface Construction.....	3-14
3.5.1	Cable Connection between the DU and the RRH-2WB.....	3-14
3.5.2	Cable Connection of RET	3-20
3.5.3	Connection of Feeder Cable	3-22
3.6	Installation Test	3-30

ANNEX A. Sector Antenna Installation **A-1**

A.1	Cautions when Installing a Sector Antenna.....	A-1
A.2	Sector Antenna Layout	A-1
A.3	Sector Antenna Installation.....	A-2

ANNEX B. Installing Feeder Cable **B-1**

B.1	Cautions When Installing Feeder Cable.....	B-1
B.2	Antenna Feeder Cable Ground	B-4
B.3	Tower Ground Construction	B-8

ANNEX C. Connector Assembly **C-1**

C.1	N type-male (1/2 in. feeder line)	C-1
C.2	Din type-male (1/2 in. Feeder Line).....	C-6
C.3	Finishing the Connector Connection Part by Tape.....	C-8
C.4	How to Shrink the Heat Shrink Tube	C-9
C.4.1	When Assembling a Connector to the Feeder Line.....	C-9
C.4.2	When Connecting a Connector to another Connector	C-11
C.5	Power Connector Assembly.....	C-15

ANNEX D. Cleaning Optic Connector D-1

D.1	Cleaning Optic Connector	D-1
D.2	IBC™ Brand Cleaner	D-2
D.2.1	IBC™ Brand Type Cleaner (P/N 9393).....	D-2
D.2.2	IBC™ Brand Type Cleaner (P/N 12910).....	D-5

ANNEX E. Pressure Terminal Assembly E-1**ANNEX F. Standard Torque F-1****ABBREVIATION I**

L ~ V.....	I
------------	---

LIST OF FIGURES

Figure 1.1	RRH-2WB Configuration.....	1-1
Figure 1.2	RRH-2WB Configuration When the Solar Shield is Assembled.....	1-2
Figure 1.3	RRH-2WB External Interface.....	1-3
Figure 2.1	Procedure to Install the RRH-2WB.....	2-1
Figure 2.2	RRH-2WB Installation Space.....	2-2
Figure 2.3	RRH-2WB Marking.....	2-3
Figure 2.4	Fixing the RRH-2WB_Wall Type (1).....	2-5
Figure 2.5	Fixing the RRH-2WB_Wall Type (2).....	2-6
Figure 2.6	Fixing the RRH-2WB_Wall Type (3).....	2-7
Figure 2.7	Example of Installing on Wall Mount Pole.....	2-8
Figure 2.8	Example of Installing on Mono Pole.....	2-9
Figure 2.9	Example of Installing on Pole.....	2-10
Figure 2.10	Example of Installing on Pole (Detail A, Detail B).....	2-11
Figure 2.11	Fixing 1 Sector Pole Type RRH-2WB (1).....	2-12
Figure 2.12	Fixing 1 Sector Pole Type RRH-2WB (2).....	2-13
Figure 2.13	Fixing 1 Sector Pole Type RRH-2WB (3).....	2-14
Figure 2.14	Fixing 3 Sector Pole Type RRH-2WB (1).....	2-15
Figure 2.15	Fixing 3 Sector Pole Type RRH-2WB (2).....	2-16
Figure 2.16	Fixing 3 Sector Pole Type RRH-2WB (3).....	2-17
Figure 2.17	Fixing 3 Sector Pole Type RRH-2WB (4).....	2-18

Figure 2.18	Fixing 3 Sector Pole Type RRH-2WB (5).....	2-19
Figure 2.19	Fixing 3 Sector Pole Type RRH-2WB (6).....	2-20
Figure 2.20	Bolt Specifications for 3 Sector Pole Type RRH-2WB-Examples.....	2-21
Figure 2.21	Example of Installing on the Tower	2-22
Figure 2.22	Fixing Tower Type RRH-2WB (1).....	2-23
Figure 2.23	Fixing Tower Type RRH-2WB (2).....	2-24
Figure 2.24	Fixing Tower Type RRH-2WB (3).....	2-25
Figure 2.25	Fixing Tower Type RRH-2WB (4).....	2-26
Figure 2.26	Fixing Tower Type RRH-2WB (5).....	2-27
Figure 2.27	Fixing Tower Type RRH-2WB (6).....	2-28
Figure 2.28	Fixing Tower Type RRH-2WB (7).....	2-29
Figure 2.29	Fixing Tower Type RRH-2WB (8).....	2-30
Figure 2.30	Leveling Test before Fixing Anchor Bolts	2-31
Figure 2.31	Leveling Test before Fixing System	2-32
Figure 2.32	Schematic Diagram for Insulation Test	2-33
Figure 3.1	Work Flow for Cabling	3-1
Figure 3.2	Cabling Diagram.....	3-5
Figure 3.3	Connection of the RRH-2WB Ground Cable	3-8
Figure 3.4	Power Equipment Diagram.....	3-10
Figure 3.5	Installing the RRH-2WB Power Cable (1).....	3-11
Figure 3.6	Installing the RRH-2WB Power Cable (2).....	3-12
Figure 3.7	Power Cable Connector	3-13
Figure 3.8	Cable connection between the DU and the RRH-2WB (Optical connection).....	3-15
Figure 3.9	Optic Cable Connector between DU and RRH-2WB_RRH-2WB side.....	3-16
Figure 3.10	Cable Connection of RET	3-20
Figure 3.11	RET Cable Connector.....	3-21
Figure 3.12	Feeder Line Connection Diagram.....	3-22
Figure 3.13	Connection of Feeder Cable (Detail A)	3-23
Figure 3.14	Connection of Feeder Cable (Detail B).....	3-24
Figure 3.15	Heat Shrink Tube Specification.....	3-26
Figure A.1	Sector Antenna.....	A-2
Figure B.1	Feeder Cable Grounding (1)	B-4
Figure B.2	Feeder Cable Grounding (2)	B-5
Figure B.3	Feeder Cable Grounding (3)	B-6
Figure B.4	Feeder Cable Grounding (4)	B-7
Figure B.5	Connecting the Tower Ground Cable	B-9

Figure C.1	Assembling the N type-male (1/2 in. Feeder Line) Connector (1)	C-2
Figure C.2	Assembling the N type-male (1/2 in. Feeder Line) Connector (2)	C-3
Figure C.3	Assembling the N type-male (1/2 in. Feeder Line) Connector (3)	C-4
Figure C.4	Assembling the N type-male (1/2 in. Feeder Line) Connector (4)	C-5
Figure C.5	Assembling the Din type-male (1/2 in. Feeder Line) Connector (1)	C-6
Figure C.6	Assembling the Din type-male (1/2 in. Feeder Line) Connector (2)	C-7
Figure C.7	Finishing the Connector Connection Part by Tape	C-8
Figure C.8	Shrinking the Heat Shrink Tube_Feeder Line (1)	C-9
Figure C.9	Shrinking the Heat Shrink Tube_Feeder Line (2)	C-10
Figure C.10	Shrinking the Heat Shrink Tube_Connection between Connectors (1)	C-11
Figure C.11	Shrinking the Heat Shrink Tube_Connection between Connectors (2)	C-12
Figure C.12	Shrinking the Heat Shrink Tube_Connection between Connectors (3)	C-13
Figure C.13	Power Connector Assembly (1)	C-15
Figure C.14	Power Connector Assembly (2)	C-16
Figure D.1	Optic Connector Cleaner (IBC™ Brand Type Cleaner: P/N 9393)	D-2
Figure D.2	Optic Module Cleaning (LC Type Jack)	D-3
Figure D.3	Optic Cable Connector Cleaning (LC Type Plug)	D-4
Figure D.4	Optic Connector Cleaner (IBC™ Brand Type Cleaner: P/N 12910)	D-5
Figure D.5	Optic Port Cleaning (ODC, PT/LC Jack)	D-6
Figure D.6	Optic Cable Connector Cleaning (ODC Type Plug)	D-7
Figure D.7	Optic Cable Connector Cleaning (PT/LC Type Plug)	D-8
Figure D.8	Measuring the Optical Output and Connecting the Optic Connector	D-9
Figure E.1	Pressure Terminal Assembly (1)	E-1
Figure E.2	Pressure Terminal Assembly (2)	E-2

LIST OF TABLES

Table 1.1	Basic Installation Tools	1-9
Table 2.1	Recommended Distances for System	2-2
Table 2.2	Anchor Bolt Drill Bits and Hole Depth	2-3
Table 3.1	Recommended Minimum Allowed Cable Bend Radius	3-3
Table 3.2	RRH-2WB Connecting Cable	3-6
Table 3.3	Amphenol CJE-AL06M25U15-2S Power Connector Pin Map	3-13
Table 3.4	Cable Spec for Mobile WiMAX Only Operation Mode	3-17

Table 3.5	Optic Connector Pin Map between RRH-2WB and DU for Mobile WiMAX Only Operation Mode	3-17
Table 3.6	Cable Spec for WIMAX + TD-LTE Dual Mode	3-18
Table 3.7	Optic Connector Pin Map between RRH-2WB and DU for WIMAX + TD-LTE Dual Mode	3-18
Table 3.8	RET Cable-side Connector Pin Map	3-21
Table 3.9	RF Cable Identification Tag	3-29
Table 3.10	Construction Situation Checklist	3-30
Table B.1	Curvature Radius of Feeder Cable for Outdoor	B-1
Table B.2	Curvature Radius of Feeder Cable for Indoor (Based on LS Feeder Line)	B-2
Table B.3	Curvature Radius of LMR-400 (Based on Times Microwave System)	B-2
Table B.4	Connector Connection Torque Value	B-3
Table B.5	TGB Installation Example	B-7
Table E.1	Compressor Specification by Cable Thickness	E-2
Table F.1	Standard Torque Value for Tightening Bolts.....	F-1

CHAPTER 1. Before Installation

1.1 System Configuration and Structure

RRH-2WB Configuration

The configuration of RRH-2WB is as follows:

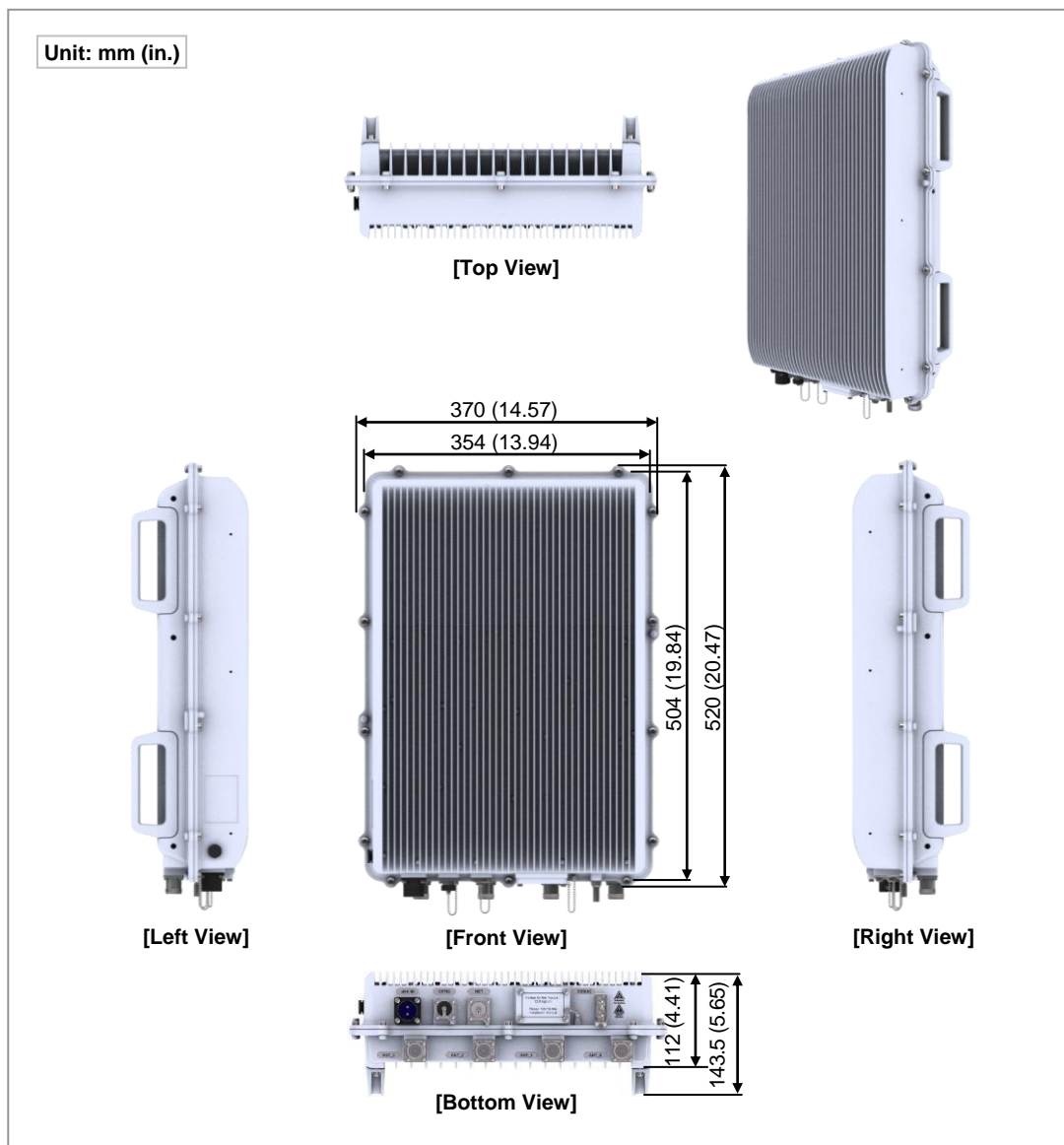

Figure 1.1 RRH-2WB Configuration

When the solar shield is assembled, the RRH-2WB should be configured as follows:

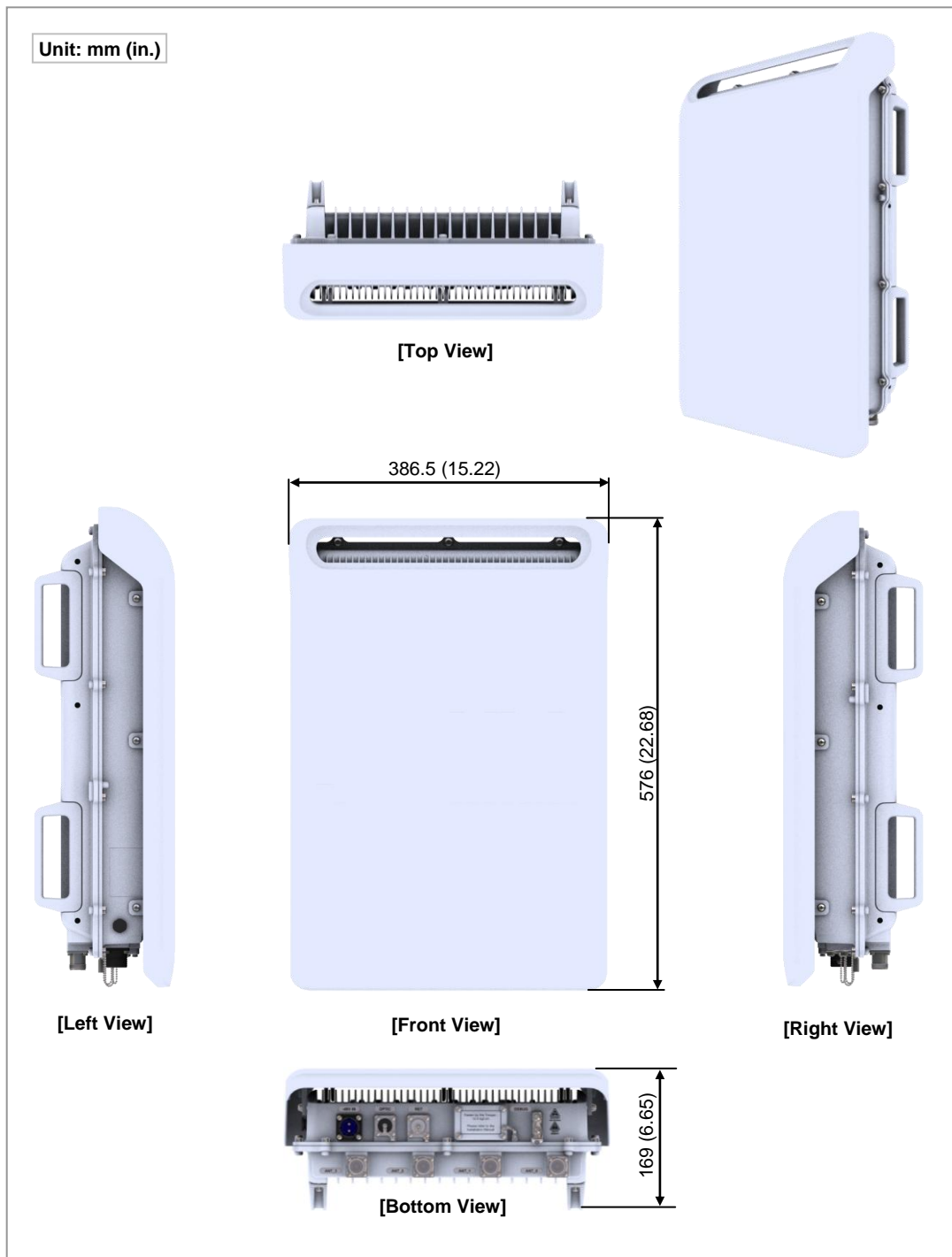

Figure 1.2 RRH-2WB Configuration When the Solar Shield is Assembled

RRH-2WB External Interface

The external interface of RRH-2WB is as follows:

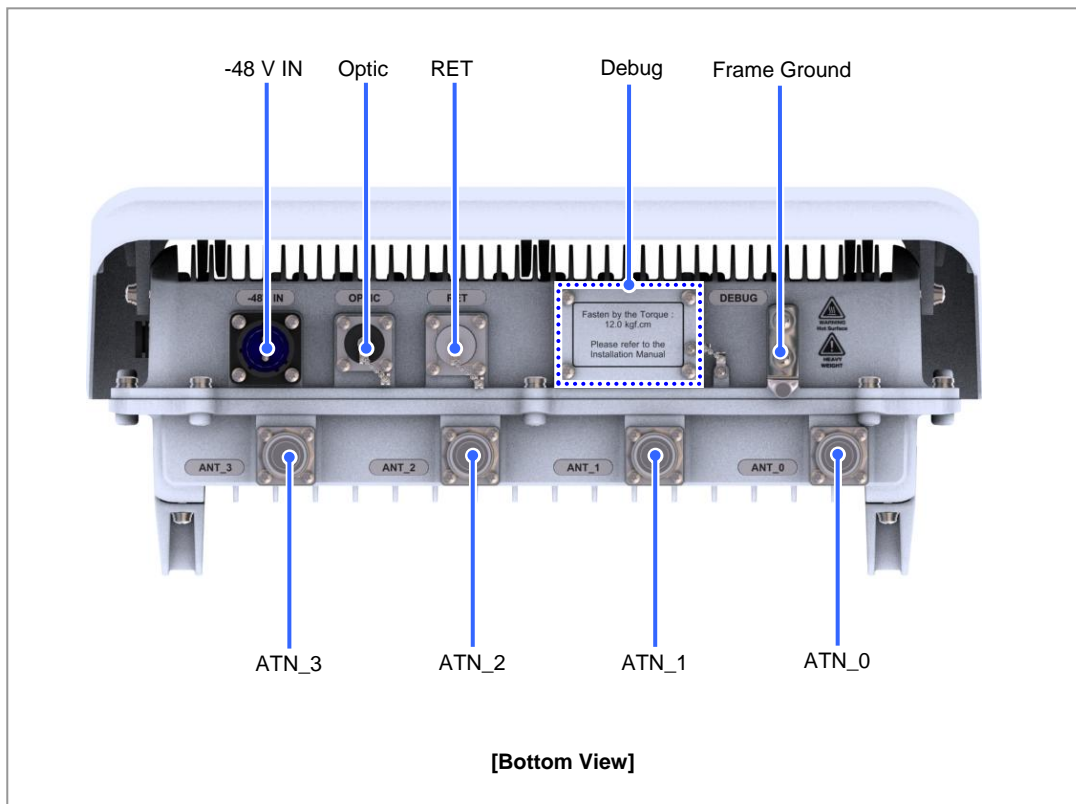

Figure 1.3 RRH-2WB External Interface

1.2 Specifications

RF Specification

The RF specification of the RRH-2WB is as follows:

Category	System Capacity
Channel Bandwidth	- Mobile WiMAX: 10 MHz - TD-LTE: 20 MHz
RF Band	2,496~2,690 MHz
Maximum Number of Carriers	- 10 MHz Mobile WiMAX 1 carrier/path - 20 MHz TD-LTE 1 carrier/path
Interface between DU and RRH-2WB	CPRI, Optic (4 Core)
In band Spectral Mask	FCC 43 + 10 logP
Tx/Rx Performance	- Mobile WiMAX: RCT - TD-LTE: 3 GPP TS 36.104
Output	Antenna Port-based - 5 W/Carrier/Path @ WiMAX 10 MHz - 10 W/Carrier/Path @ TD-LTE 20 MHz

Input Power

The table below lists the power standard for the RRH-2WB.

Category	Standard
System Input Voltage	-48 VDC (Voltage Variation Range: -40~-56 VDC)
System Input Current (Max.)	6.25 A @ -48 V



NOTE

System Input Voltage

If the operator wants AC power for the system input voltage, it can be supplied using an additional external rectifier.

Unit Size and Weight

The table below lists the size and weight of the RRH-2WB.

Category	Standard
Size	mm 354 (W) × 112 (D) × 504 (H)
	in. 13.94 (W) × 4.41 (D) × 19.84 (H)
Weight	kg 20.4 or less
	lb 45 or less

Environmental Condition

The table below lists the environmental conditions and related standards such as operational temperature and humidity.

Category	Range
Temperature Condition ^{a)}	-40~+50°C (-104~122°F)
Humidity Condition ^{a)}	5~100%, condensing, not to exceed 30g/m ³ absolute humidity
Altitude	-60~1,800 m (197~6,000 ft)
Vibration	GR-487-CORE Sec.3.39 - Transportation shock - Transportation vibration - Installation shock - Environmentally induced vibration - Earthquake resistance
Noise (sound pressure level)	Under 65 dBA in height of 1.0 m (3 ft) and distance of 1.5 m (5 ft).
Electromagnetic Wave (EMI)	FCC Title 47 Part 15 Class B EN 301 489 Section 7.1 EMC emission GR-1089-CORE(Issue4) Sec. 3.2 Emission Criteria
RF Regulation	FCC Title 47 Part 27

a) The standards of temperature/humidity conditions are based on the value on the position where is 400 mm (1.3 ft) away from the front of the DU and in the height of 1.5 m (5 ft) on the bottom.

RF Specification

The table below lists the RF characteristics of the RRH-2WB.

Category	Description
Total Tx Output Power	30 W - Mobile WiMAX: 5 + 5 W - TD-LTE: 10 + 10 W
Tx Constellation error	- Mobile WiMAX: RCT - TD-LTE: 3 GPP TS 36.104
RX Sensitivity	- Mobile WiMAX: RCT - TD-LTE: 3 GPP TS 36.104

1.3 Cautions for Installation

Observe the following safety instructions when installing the RRH-2WB:

Before Installing

- Post warning signs in areas where high-voltage cables are installed.
- Post 'off limit' signs in areas where accidents are most expected.
- With guardrails or fences, block open areas such as connecting parts, roof, and scaffold.

While Installing

- The power must be cut off before installing.
- Be careful that boards mounted on the system and the cables among the boards are damaged or scratched when the system is transported or installed.



Power Switch Off

Make sure the power switch of power supplier is off when installing the system. Installing the system with power switch on may cause system damage or fatal human injury when cables are not correctly connected.



Protection gloves and goggles

Make sure that worker wears protection gloves and goggles to prevent damages from debris while drilling holes in a wall or ceiling.



Watches, Rings, and Other Metallic Accessories

Do not wear accessories such as watches and rings in order to prevent electrical shock.



Do not Work by Yourself

Worker must not work alone in any key process.



System Installation and Access

Only authorized workers are allowed to install or access the system.

**CHECK****Fixing Materials for outdoor**

Stud bolts, Hex. nuts, spring washers, and plane washers that are used to fix the pole should be made of stainless materials (STS 304). If not, the joint parts may oxidize or gather rust.

After Installing

- Cover the cable holes drilled on the floor with a solid cover.
- Remove any debris produced during the work and clean up the installation site.

**WARNING****Warning for Laser Beam Running through Optical Cables**

In the system, the laser beam emitting light runs through the optical cable. The exposure of the laser beam on worker's eye may cause serious injury so that it should be handled with care.

**CAUTION****Cautions while Cleaning the Rack**

Make sure that worker does not damage installed cables while cleaning the rack.

**CAUTION****Cautions while Cleaning Power Supply**

While cleaning the power supply device, take caution that the device does not come in contact with alien bodies that may cause power failure.

**CAUTION****Management of Unused Ports**

Cover the unused ports (conduit, cable gland, etc.) with waterproof cap (sealing cap) to prevent infiltration of foreign material such as dust, moisture, or bug.

1.4 Pre-survey

Before starting the construction, the constructor and the departments concerned with the construction inspect the following items with a pre-survey checklist for the smooth progress of the construction. If any insufficiencies or problems are found, make the plan upon deliberation with the departments.

Installation/construction personnel and the service provider carry out the site survey for the system installation focusing on the following items:

- Examination about the conformance and the economical efficiency of the place that the system is transported or installed.
- Status of external interfaces
- Power capacity and wiring status
- Possibility of system extension
- Review if the place has the enough space to operate and maintain.

1.5 Installation Tools

The basic tools for installation are listed in the table below. The additional tools required for each site need to be identified and prepared during a site survey before starting installation.

Table 1.1 Basic Installation Tools

No.	Name	Specification
1	Torque driver set	- No.0~+ No.3 (M2.6~M6 '+' Driver) - 1.0~60 kgf.cm (0.07~4.34 lbf·ft)
2	Torque wrench set	- M6~M12 - 10~30 kgf.cm (0.72~2.17 lbf·ft), 100~500 kgf.cm (7.23~36.15 lbf·ft), Replaceable head
3	Nut driver set	6~10 mm (0.24~0.39 in.)
4	Hacksaw Frame/Blade	Normal/HIS
5	Level/Plumb bobs	Normal/500 g (1.10 lb)
6	Heating gun	50~300°C (122~572°F)
7	Solder	30~130 W
8	Power extension cable	30 m
9	Tape measure	5 m/50 m (196.85 in./1.97 in.)
10	Cable cutter	325 mm (12.80 in.)
11	Silicon gun/Silicon	Normal/Gray & Colorless
12	Spanner	19 mm, 24 mm, 36 mm (0.75 in. 0.94 in. 1.42 in.)



NOTE

Precautions when Using the Installation Tools

The required installation tools may vary depending on the conditions at the site. In addition to the basic tools, a protractor, compass, GPS receiver, ladder, safety equipment, cleaning tools etc. should also be prepared in consideration of the site conditions.

CHAPTER 2. Installing System

2.1 Installing the RRH-2WB

The procedure to install the RRH-2WB is listed in the flow chart below.

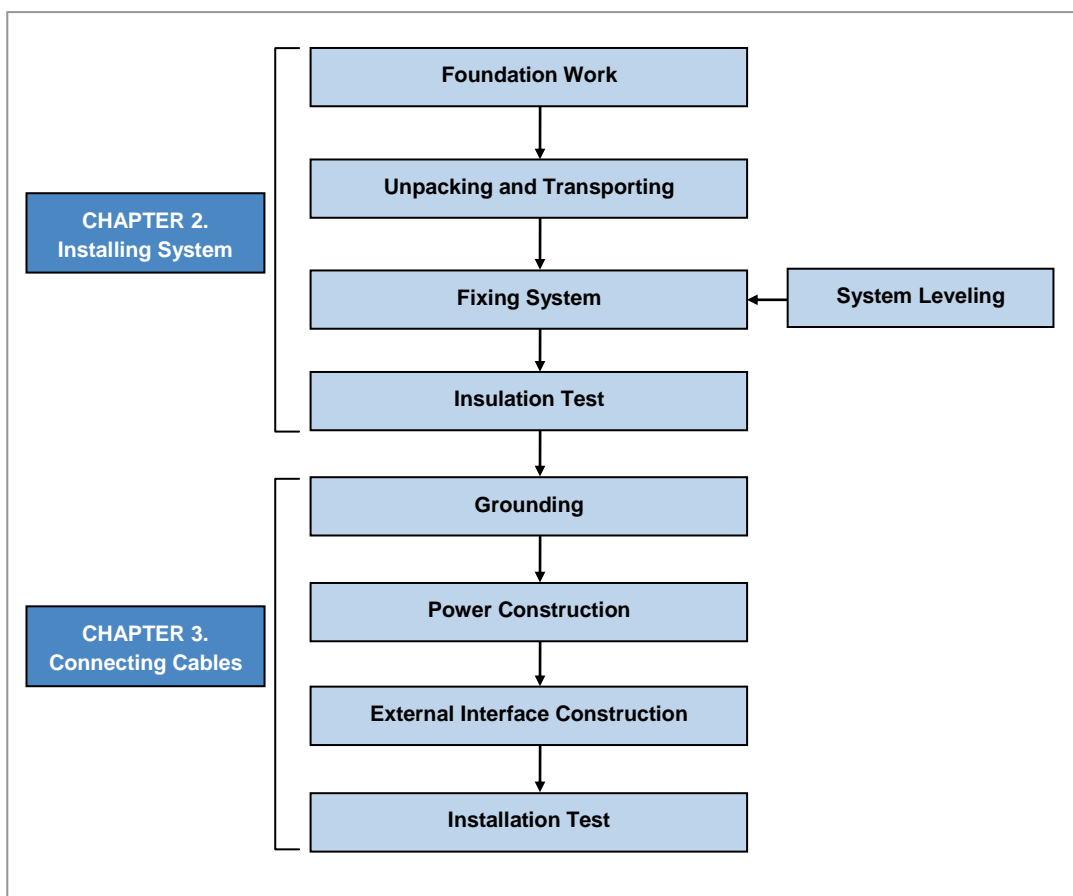

Figure 2.1 Procedure to Install the RRH-2WB

2.2 Foundation Work

2.2.1 System Arrangement

A certain distance must be secured around the RRH-2WB in each direction for installation and maintenance.

Table 2.1 Recommended Distances for System

Category	Recommended Distances
Front/Rear	800 mm (31.50 in.) or more
Side	200 mm (7.87 in.) or more
Top/Bottom (In case of Pole Type)	1,000 mm (39.37 in.) or more

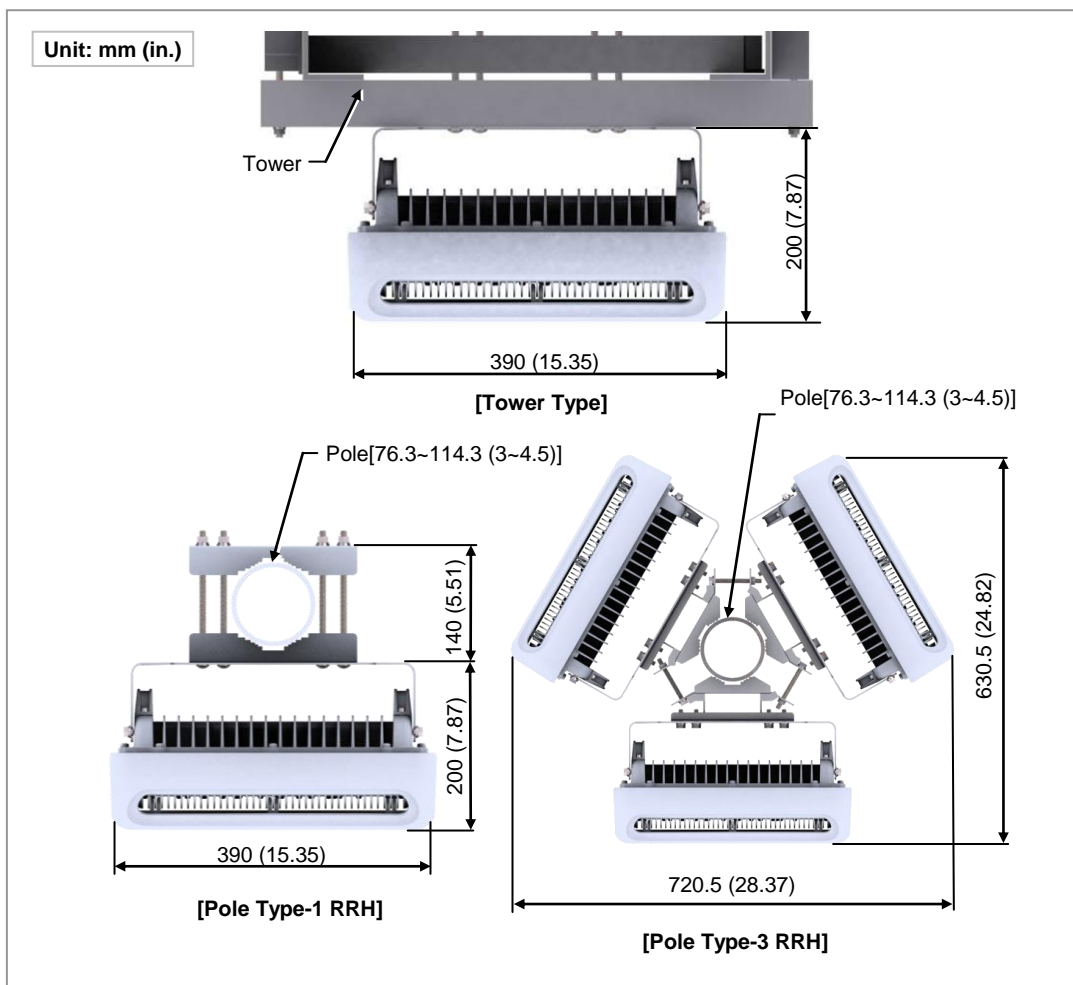

Figure 2.2 RRH-2WB Installation Space



NOTE

System Installation Spaces

The space specifications in the Figure above apply when the pole diameter is 101.6 mm (4 in.). The dimensions may vary depending on the diameter of the pole.

2.2.2 Marking and Drilling

System marking helps install the system in a precise location by marking the locations of the system, anchor bolts, and cable racks on the floors, walls, and ceilings. When marking is completed, drill holes for anchor bolts.

- 1) On the location of the system installation, mark the positions of the equipment and anchor bolts as shown in the Figure below.
- 2) Drill holes to insert the anchor bolts and cover the holes with acetate tape before installing the system.

Table 2.2 Anchor Bolt Drill Bits and Hole Depth

Mounting Method	Anchor Bolt	Drill Bits	Hole Depth
Wall mount	M6	10 mm (0.39 in.)	33 mm (1.3 in.)

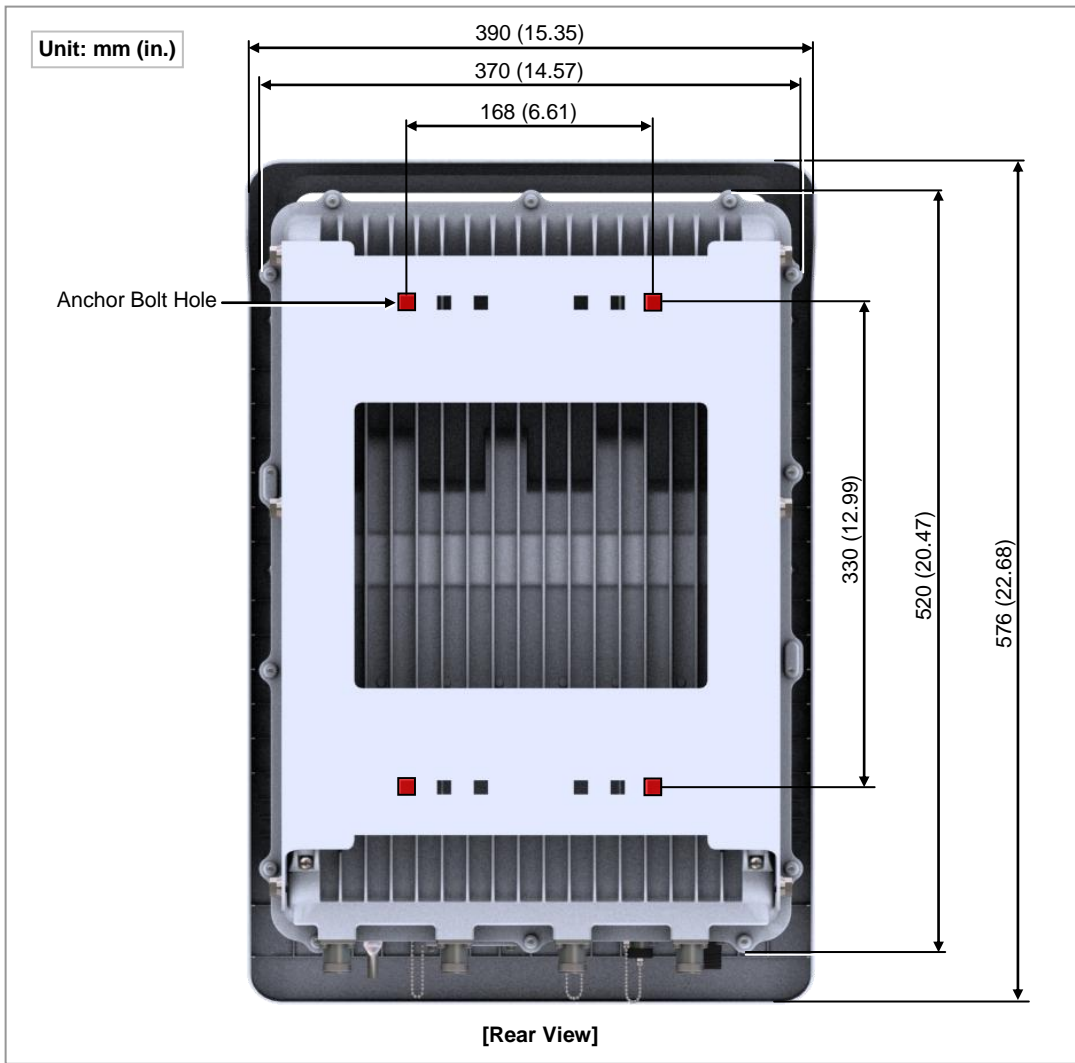

Figure 2.3 RRH-2WB Marking

2.3 Unpacking and Transporting

This paragraph describes the work to unpack cabinets and other components and transport them to the place to be installed. The cabinet is externally packed and cabinet and other components are individually packed.

- The external packing should be unpacked in the outside. If necessary, the packing can be unpacked after transported into the area near installation place.
- Transport the cabinet to the installation place. Beware of the damage of walls, pillars, and bottom of the passage when transporting the cabinet.
- Transport other components with packing and sort by types.

2.3.1 Importing Items

Bring in items, taking care of the followings:

- Regarding equipment weight and size, check the path to bring the equipment. Lay Iron and veneer boards on stairs or doorsills to make the transportation easy.
- When bring in equipment, beware of damage or impairment of main entrance, walls, pillars, and floors of the station. Prepare protection materials and fix them with a high-strength adhesive.
- Carry boards in packing status, and unpack them when installing or mounting.

Vibration Level for Transportation

When carrying the system, fasten the system firmly not to exceed the proper vibration level from 1 to 500 Hz.

When carrying system, use a lift to prevent accidents. However, if the system should be carried by people, enough people are required to carry the system.

Before moving the system, check the storage place for the system and remove obstacles in advance. While moving system, boards and other devices should not be shocked physically and damaged caused by dust, moisture, and static electricity.

When installing the items imported, system must be installed in a location whose access is not easy from outside.

2.3.2 Unpacking Items

The procedure to unpack items is as follows:

- 1) The packing items should be packed until they reach the installation place.
- 2) The items are classified in accordance with each job specification and stored on a place that does not interfere with working.
- 3) Unpacked systems should be installed immediately. If not installed immediately, the systems should be stored in the installation place temporarily.
- 4) Unpack only external packing, leaving the internal packing in unpacked status.
- 5) Unpack the inner packaging after each system is placed on its installation location.
- 6) Do not recycle packaging waste. Dispose of it in consultation with the provider.

2.4 Fixing the System

2.4.1 Fixing the Wall Type RRH-2WB

The procedure for fixing the wall type RRH-2WB is as follows:

1) Fixing the RRH-2WB Unit Mounting Bracket

- 1) To mount the RRH-2WB on the wall, first fix an M6 anchor bolt assembly at the marked location on the wall.
- 2) Fit the rubber pads, the bakelites, and the RRH-2WB unit mounting bracket to the fixed M6 anchor bolt assembly, and firmly fix them using the M6 insulation bushings, plane washers, spring washers, and Hex nuts in the order.

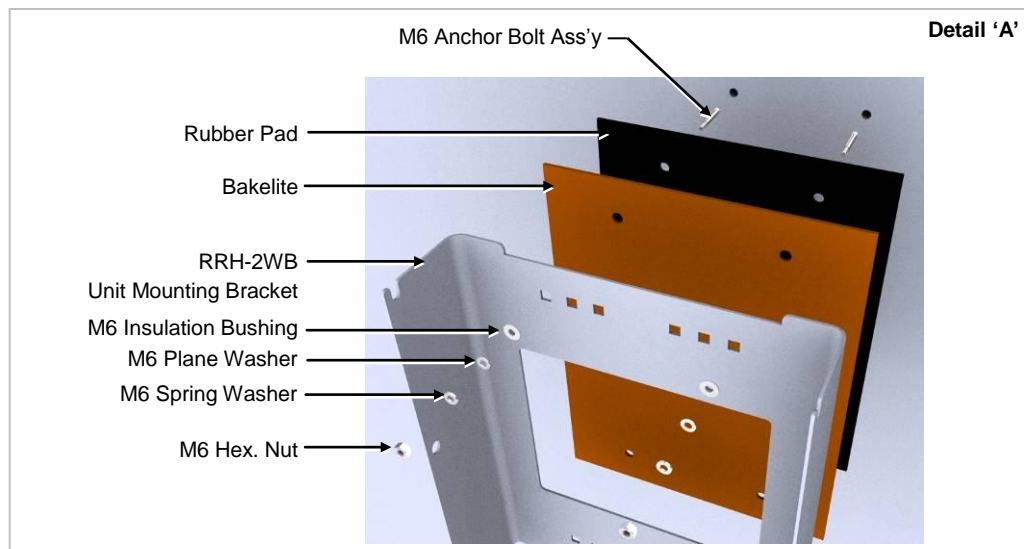
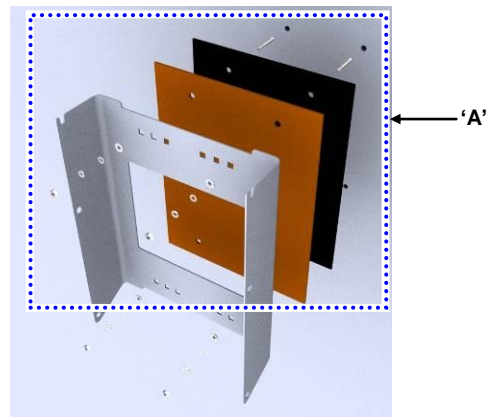

Figure 2.4 Fixing the RRH-2WB_Wall Type (1)

2) Fixing the RRH-2WB to the RRH-2WB Unit Mounting Bracket

Temporarily fix the M8 hex. bolt, plane washer, and spring washer loosely to the left/right fixing hole on the top of the RRH-2WB. Hang the RRH-2WB to the hooking holes at the top of the RRH-2WB unit mounting bracket. Then align the RRH-2WB with the fixing holes of the RRH-2WB unit mounting bracket and fix them firmly.

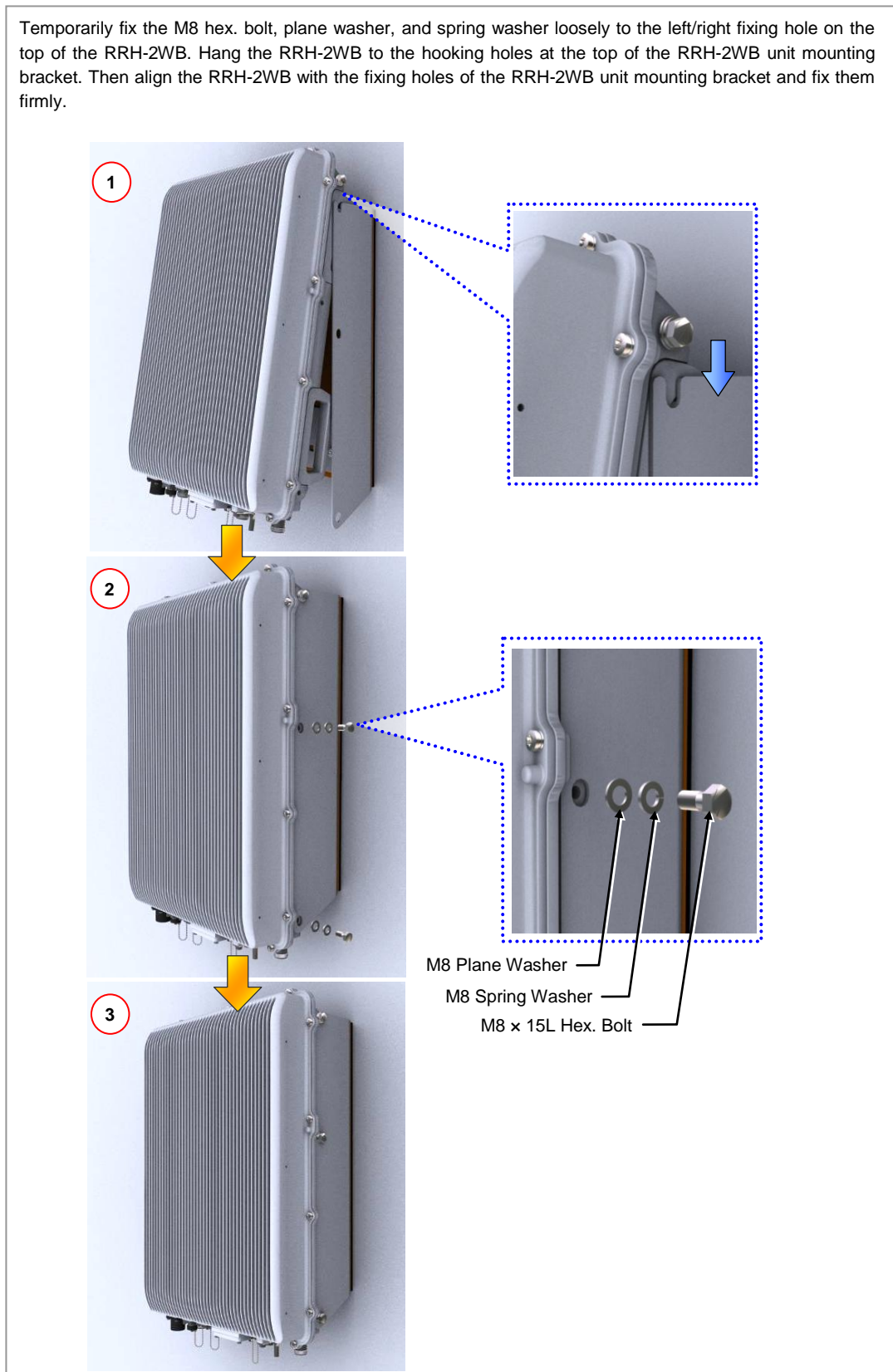

Figure 2.5 Fixing the RRH-2WB_Wall Type (2)

3) Assembling the Solar Shield to RRH-2WB

Align the solar shield cover with the fixing holes of the RRH-2WB and then fix them firmly using M5 SEMS screws.

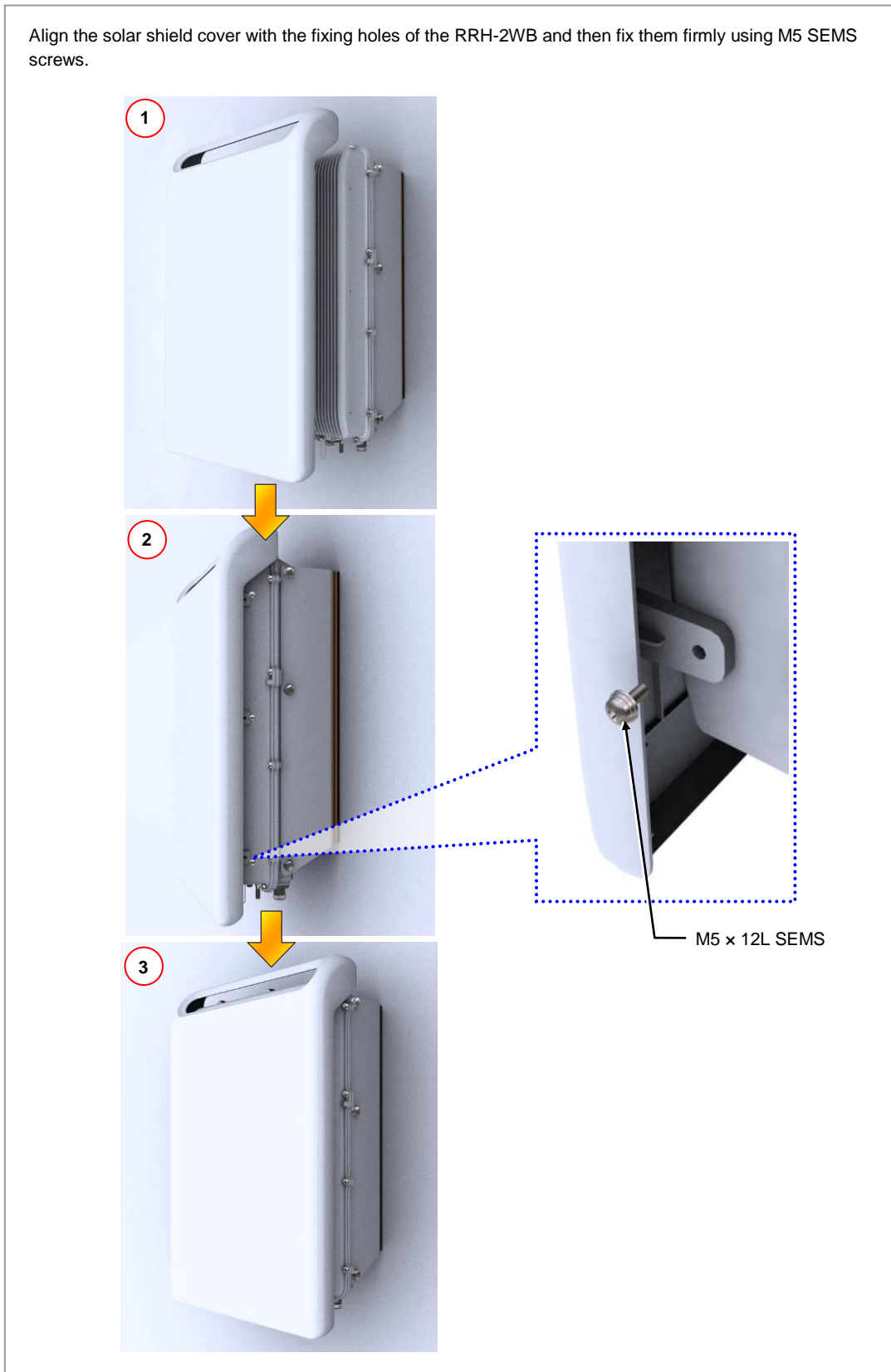

Figure 2.6 Fixing the RRH-2WB_Wall Type (3)

2.4.2 Fixing the Pole Type RRH-2WB

Installing on Wall Mount Pole

The following is an example of installing RRH-2WB and a sector antenna to the wall mount pole:

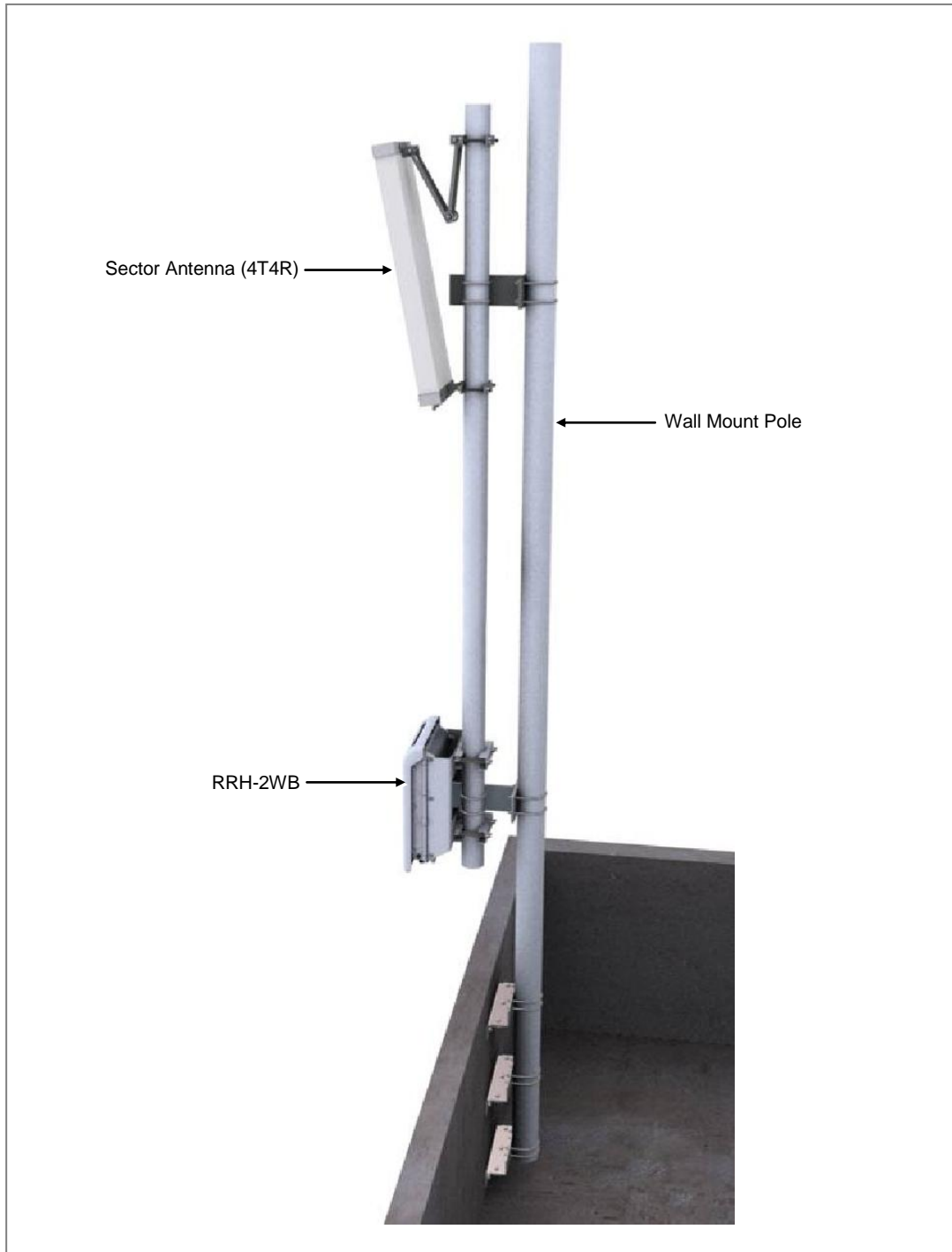

Figure 2.7 Example of Installing on Wall Mount Pole

Installing on Mono Pole

The following is an example of installing RRH-2WB and a sector antenna to the mono pole:

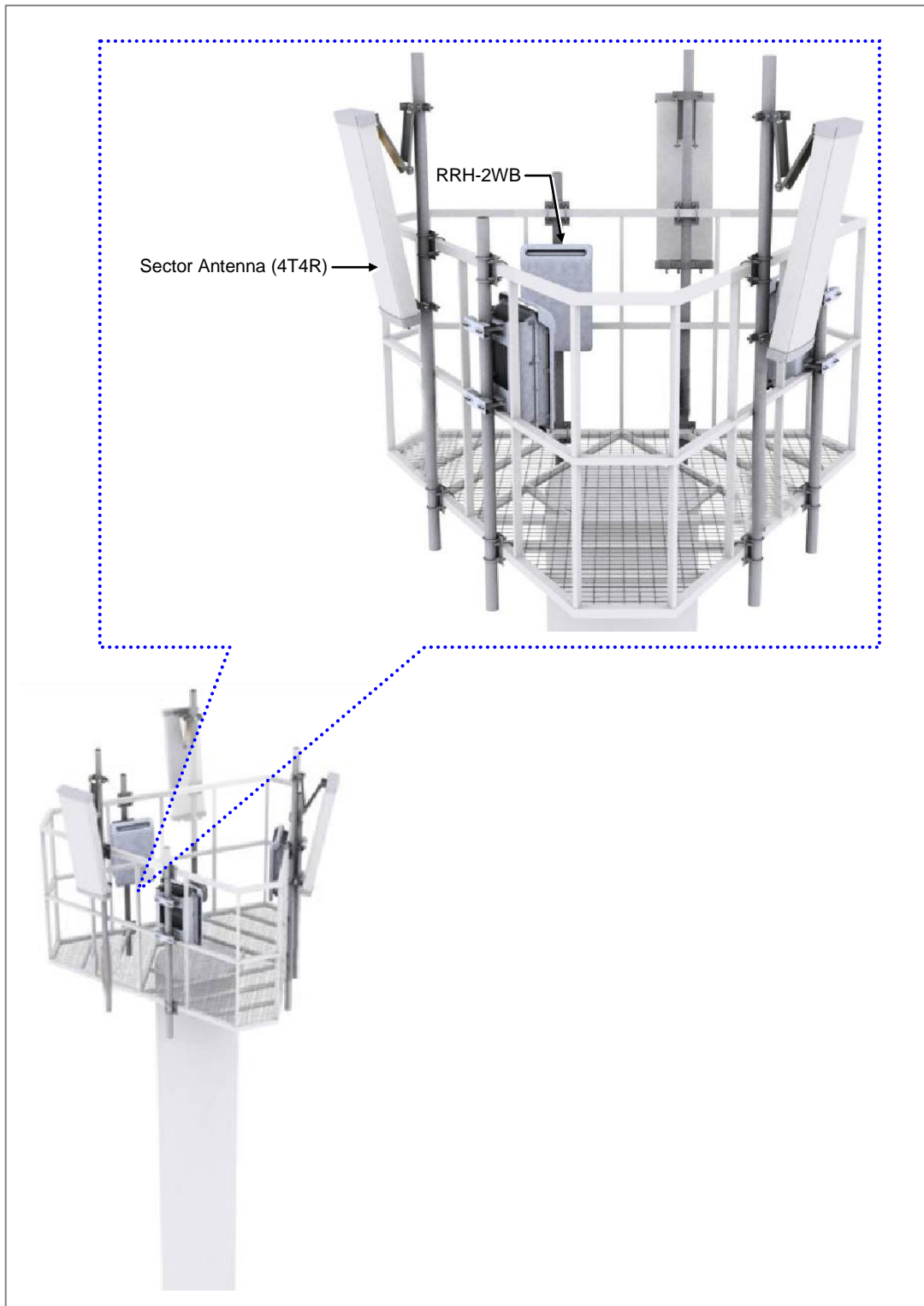

Figure 2.8 Example of Installing on Mono Pole

Installing on Pole

The following is an example of installing RRH-2WB and a sector antenna to the pole:

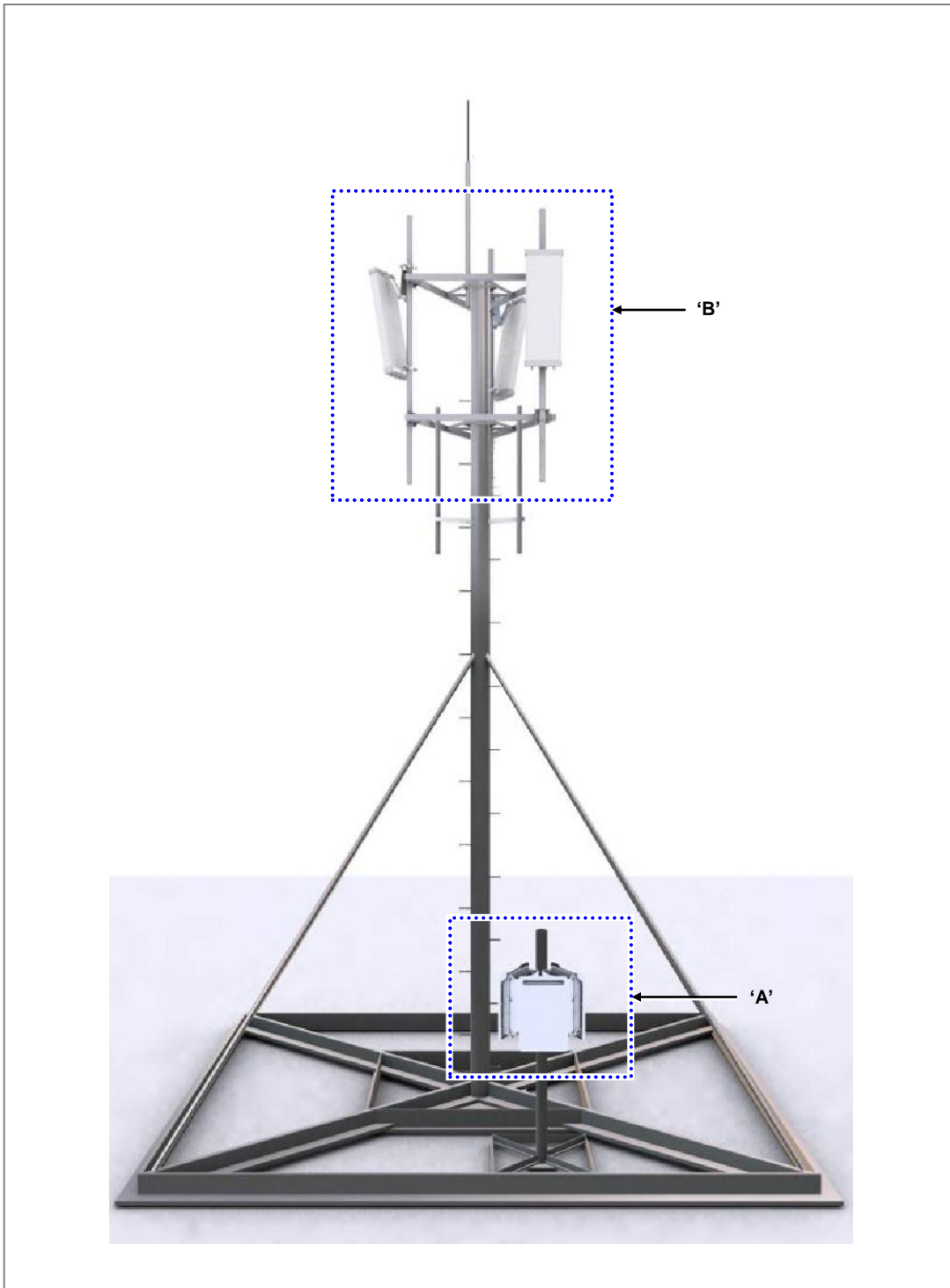

Figure 2.9 Example of Installing on Pole

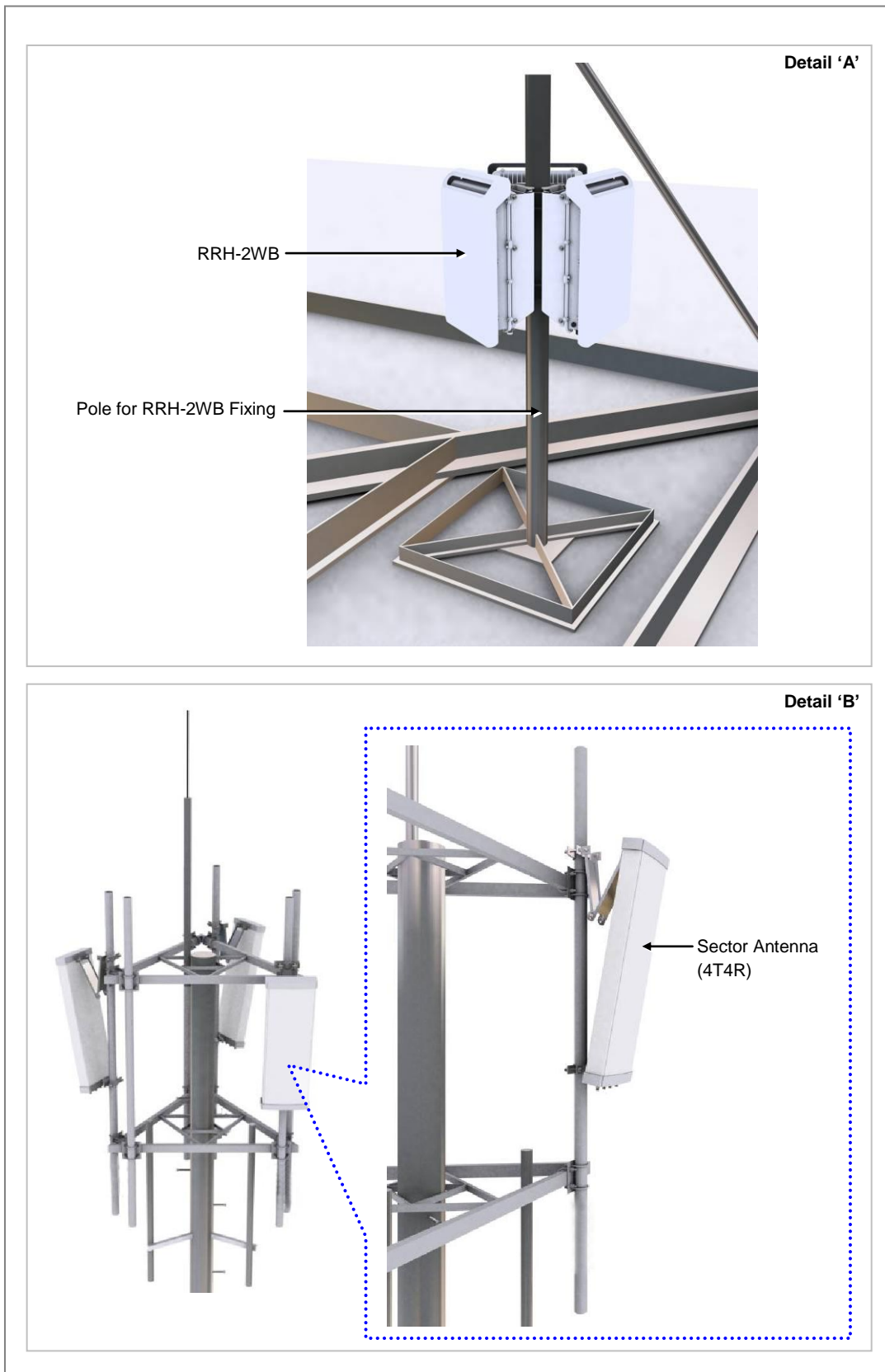

Figure 2.10 Example of Installing on Pole (Detail A, Detail B)

2.4.2.1 Fixing 1 Sector Pole Type RRH-2WB

Fix 1 sector pole type RRH-2WB in the following steps.

1) Fixing the RRH-2WB Unit Mounting Bracket and Pole Mount Bracket

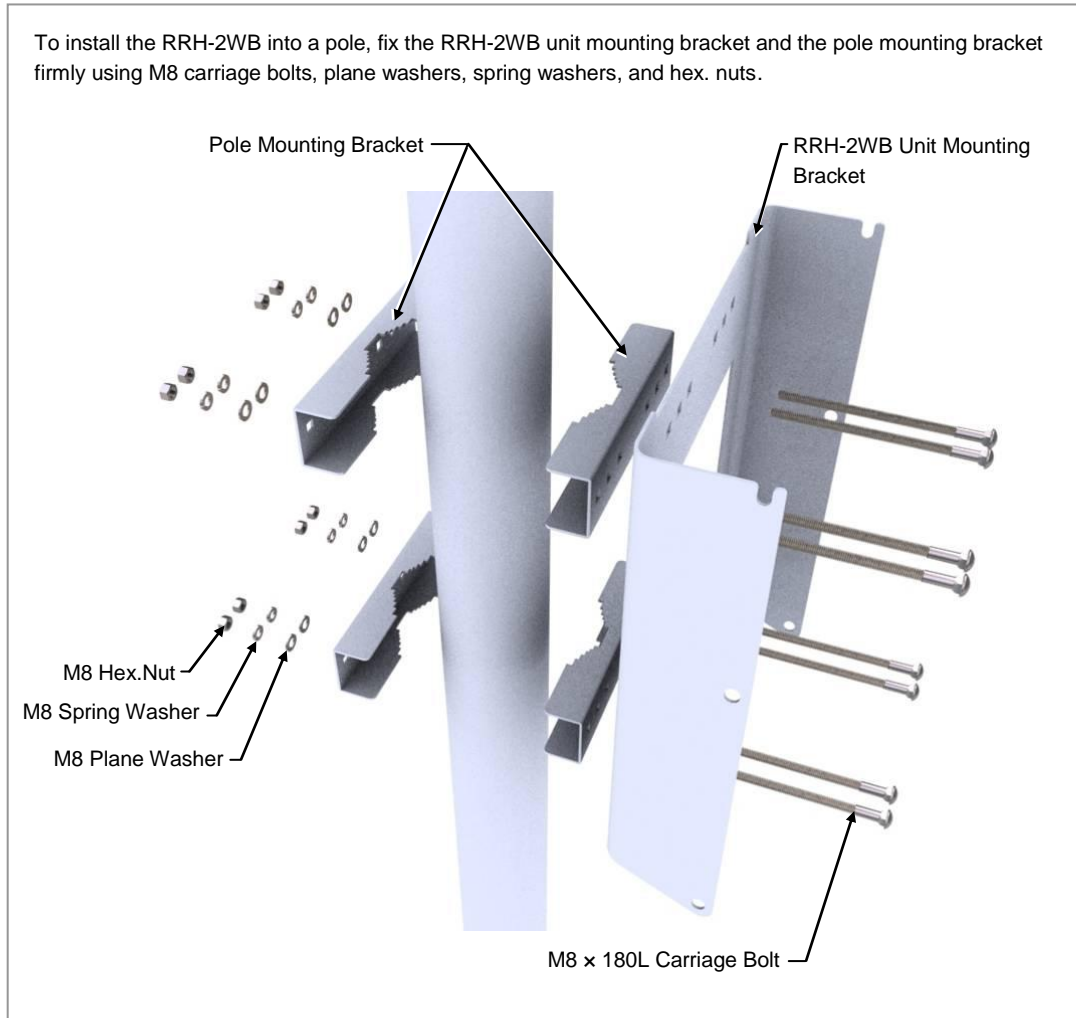

Figure 2.11 Fixing 1 Sector Pole Type RRH-2WB (1)

2) Fixing the RRH-2WB to the RRH-2WB Unit Mounting Bracket

Temporarily fix the M8 hex. bolt, plane washer, and spring washer loosely to the left/right fixing hole on the top of the RRH-2WB. Hang the RRH-2WB to the hooking holes at the top of the RRH-2WB unit mounting bracket. Then align the RRH-2WB with the fixing holes of the RRH-2WB unit mounting bracket and fix them firmly.

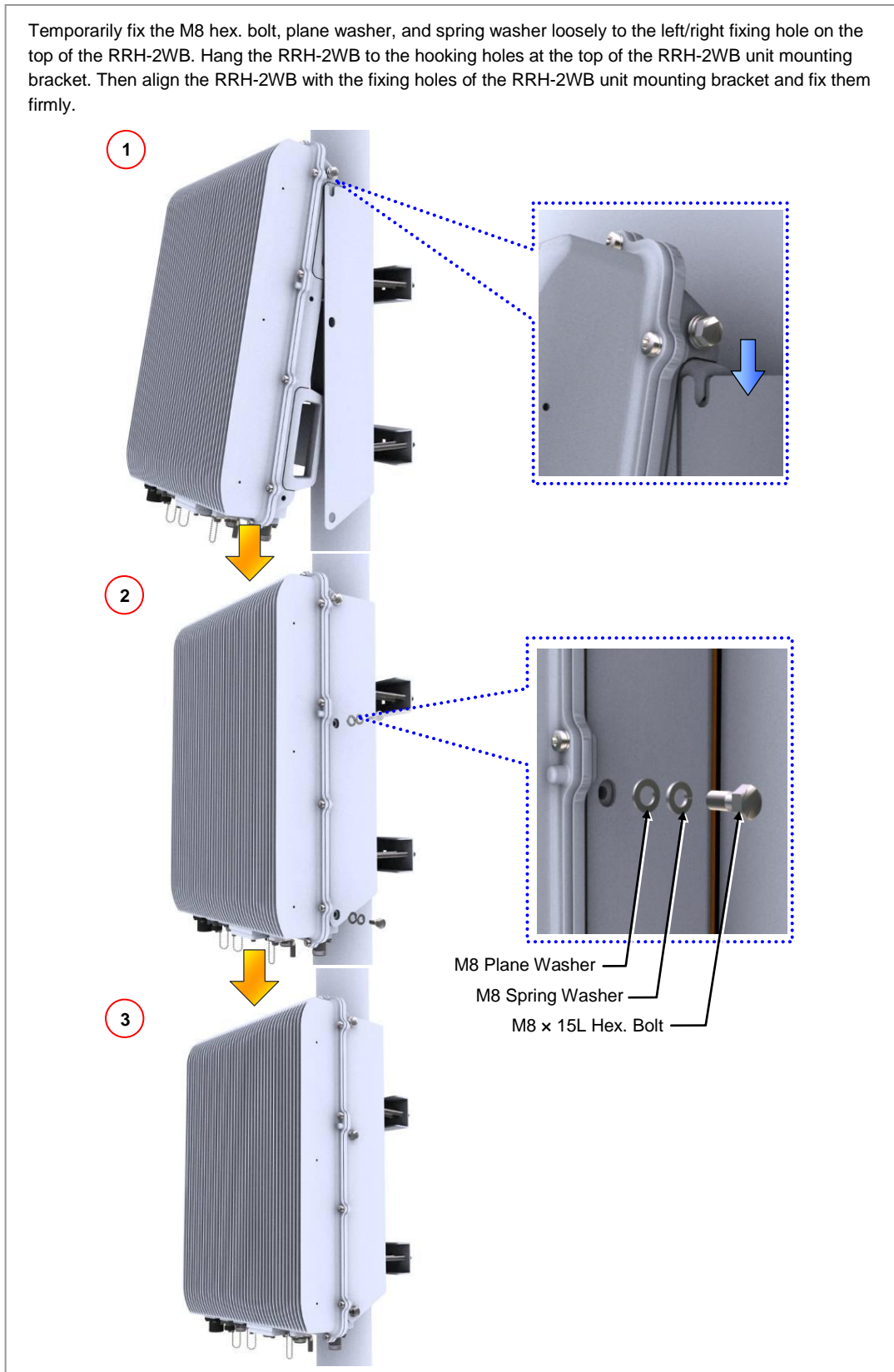

Figure 2.12 Fixing 1 Sector Pole Type RRH-2WB (2)

3) Assembling the Solar Shield to RRH-2WB

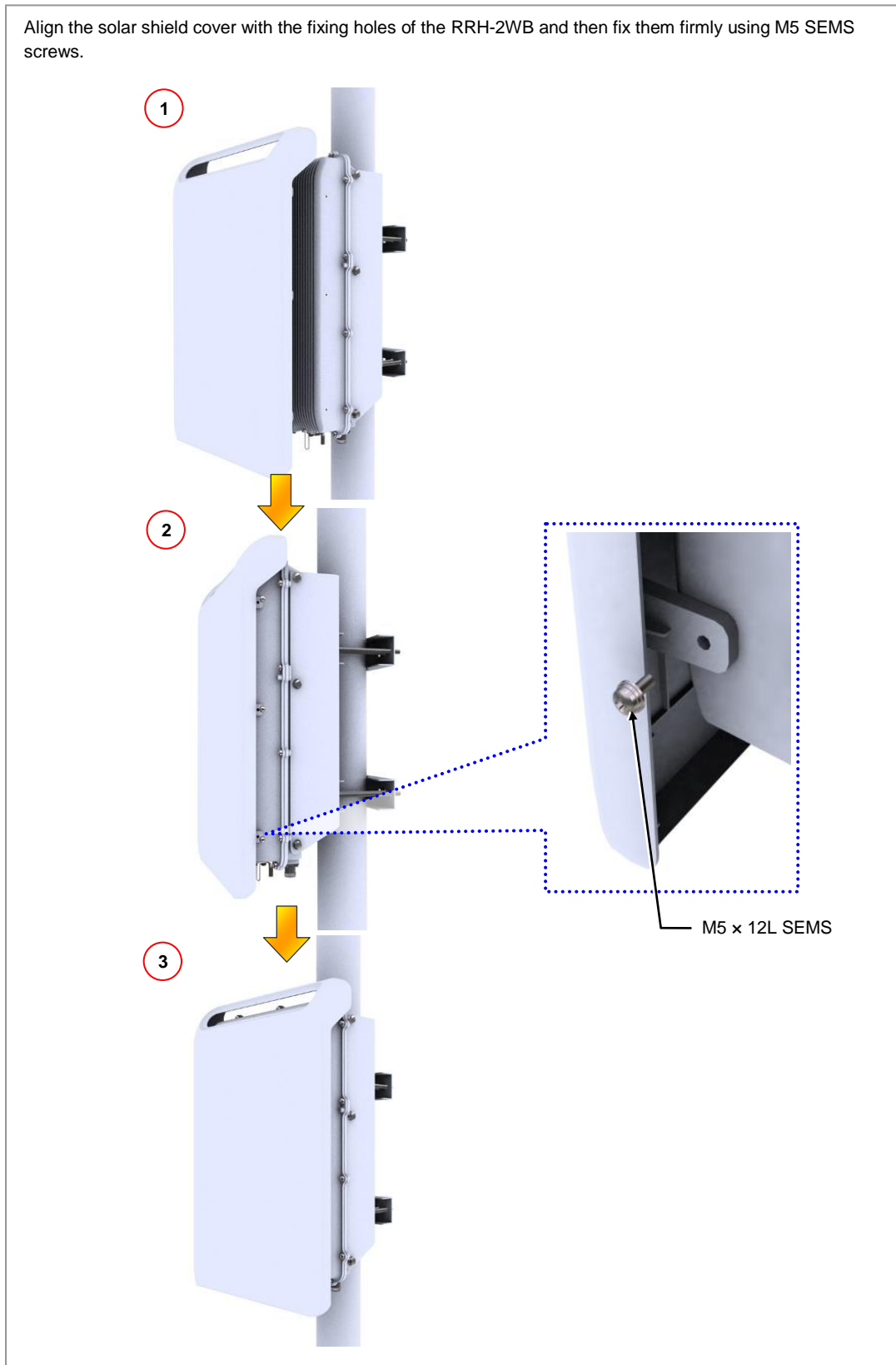

Figure 2.13 Fixing 1 Sector Pole Type RRH-2WB (3)

2.4.2.2 Fixing 3 Sector Pole Type RRH-2WB

Fix 3 sector pole type RRH-2WB in the following steps.

1) Assembling 3 sector Pole Mount Bracket

Attach a pole mount bracket-jig to the 3 sector pole mount brackets. Fix the brackets to each other using M4 flat head screws at 8 fixing spots.

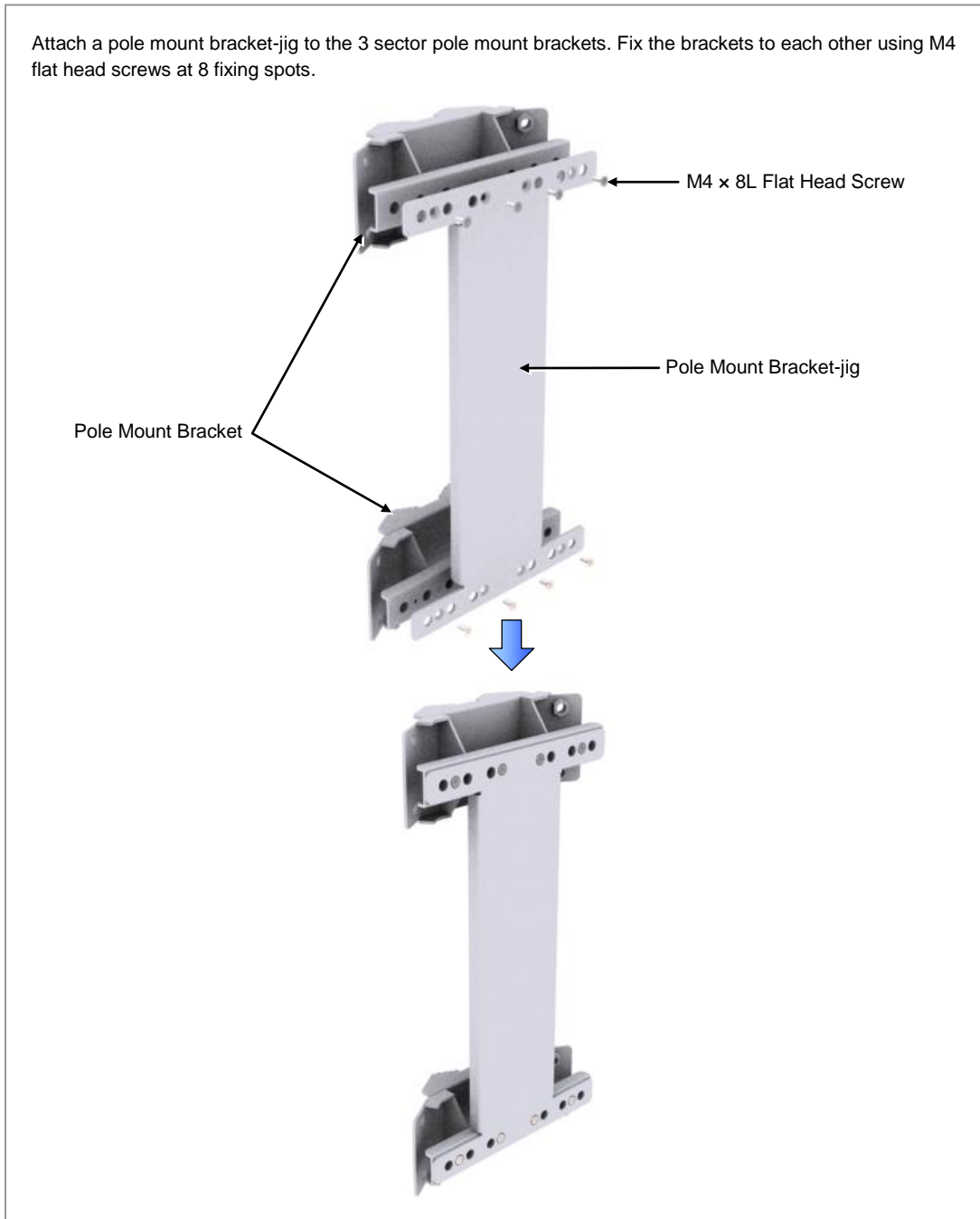

Figure 2.14 Fixing 3 Sector Pole Type RRH-2WB (1)

2) Fixing 3 sector Pole Mount Bracket Assemblies 1 and 2



Figure 2.15 Fixing 3 Sector Pole Type RRH-2WB (2)

3) Fixing the 3 sector Pole Mount Bracket Assembly to the Pole

Fix 3 Sector pole mount bracket assembly 3 to the 3 sector pole mount bracket assemblies 1 and 2. Firmly fix the assemblies to each other using M8 × 80L Hex. bolts, spring washers, and plane washers.

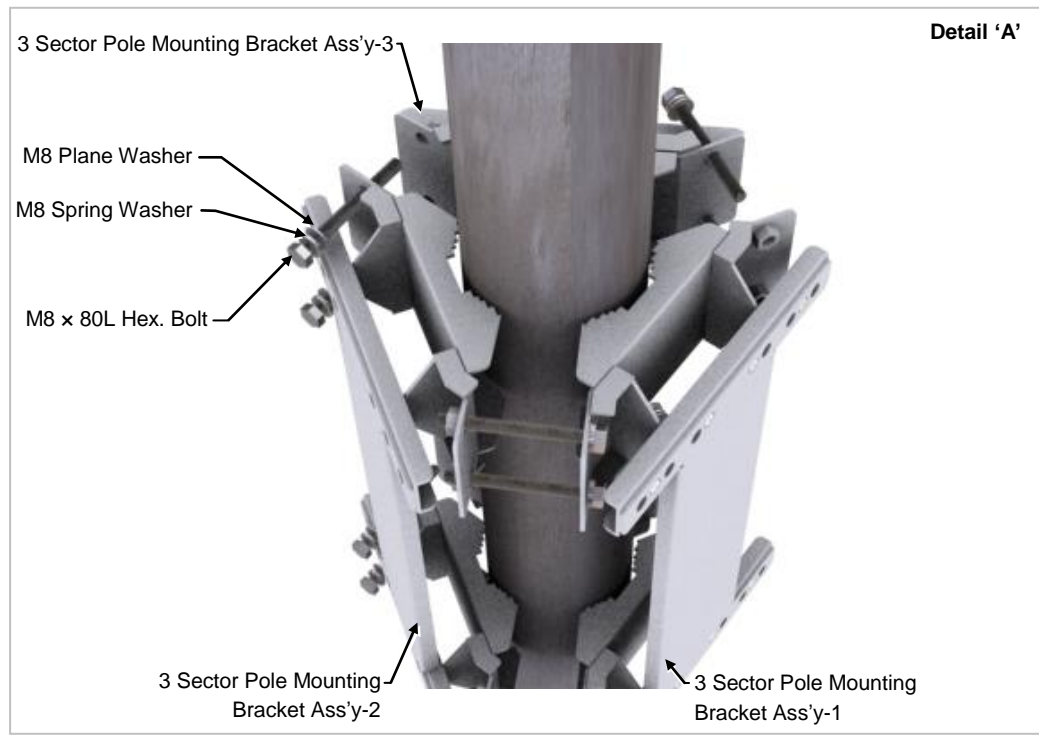
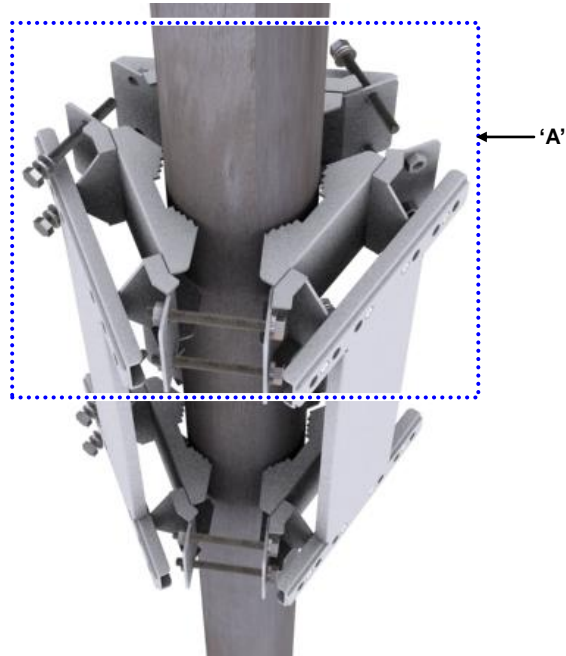

Figure 2.16 Fixing 3 Sector Pole Type RRH-2WB (3)

4) Fixing the RRH-2WB Unit Mounting Bracket to the 3 sector Pole Mount Bracket Assembly

Fix the RRH-2WB unit mounting brackets to the 3 sector pole mount bracket assembly attached to the pole. At this time, the RRH-2WB unit mounting brackets should be firmly fixed using M8 Hex. bolts, spring washers, and plane washers. Use four sets at the bottom and the top as shown in the Figure.

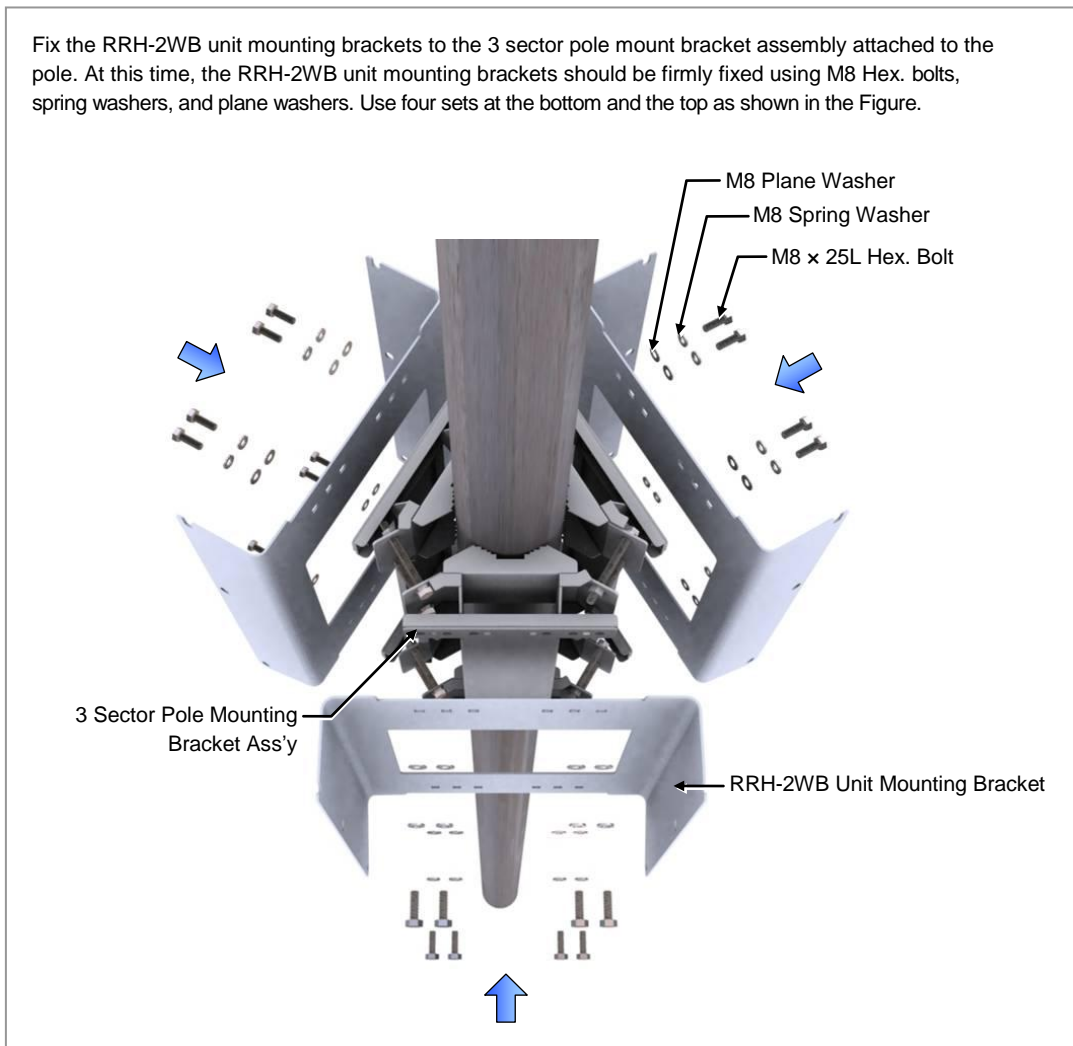

Figure 2.17 Fixing 3 Sector Pole Type RRH-2WB (4)

5) Fixing the RRH-2WB to the RRH-2WB Unit Mounting Bracket

Temporarily fix the M8 hex. bolt, plane washer, and spring washer loosely to the left/right fixing hole on the top of the RRH-2WB. Hang the RRH-2WB to the hooking holes at the top of the RRH-2WB unit mounting bracket. Then align the RRH-2WB with the fixing holes of the RRH-2WB unit mounting bracket and fix them firmly.

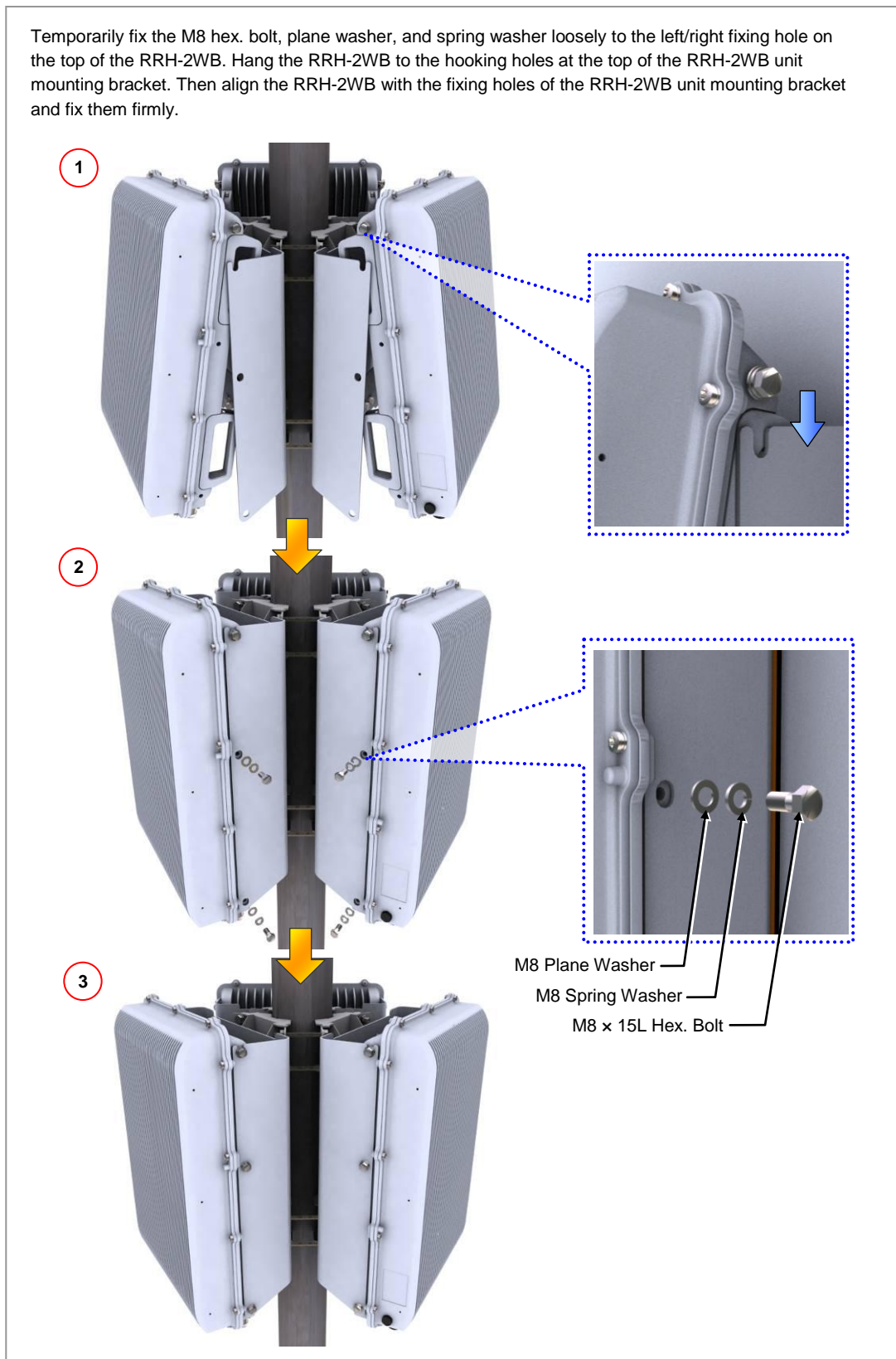

Figure 2.18 Fixing 3 Sector Pole Type RRH-2WB (5)

6) Assembling the Solar Shield Cover to RRH-2WB

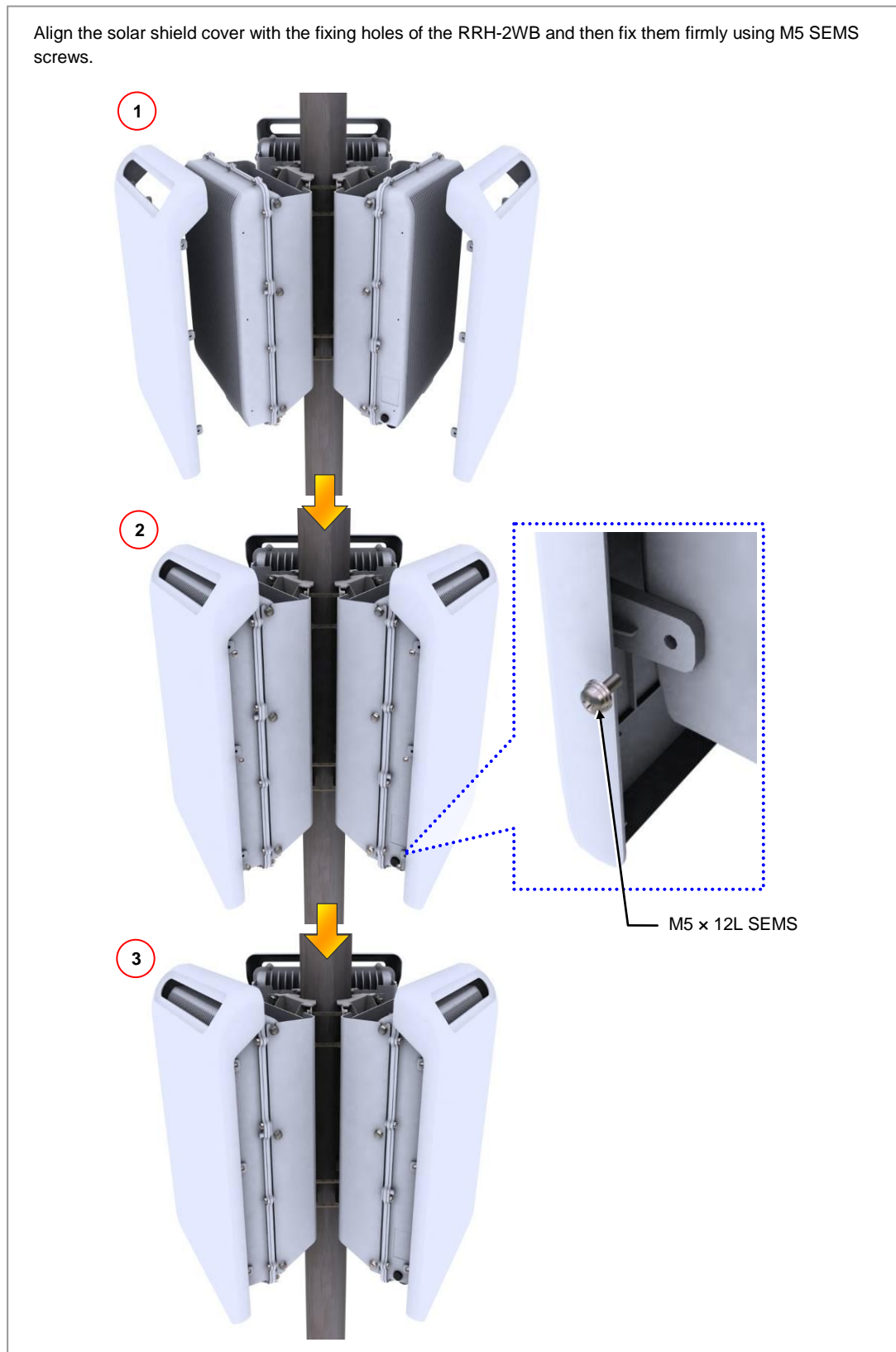

Figure 2.19 Fixing 3 Sector Pole Type RRH-2WB (6)

Bolt Specifications for 3 Sector Pole Type RRH-2WB-Examples

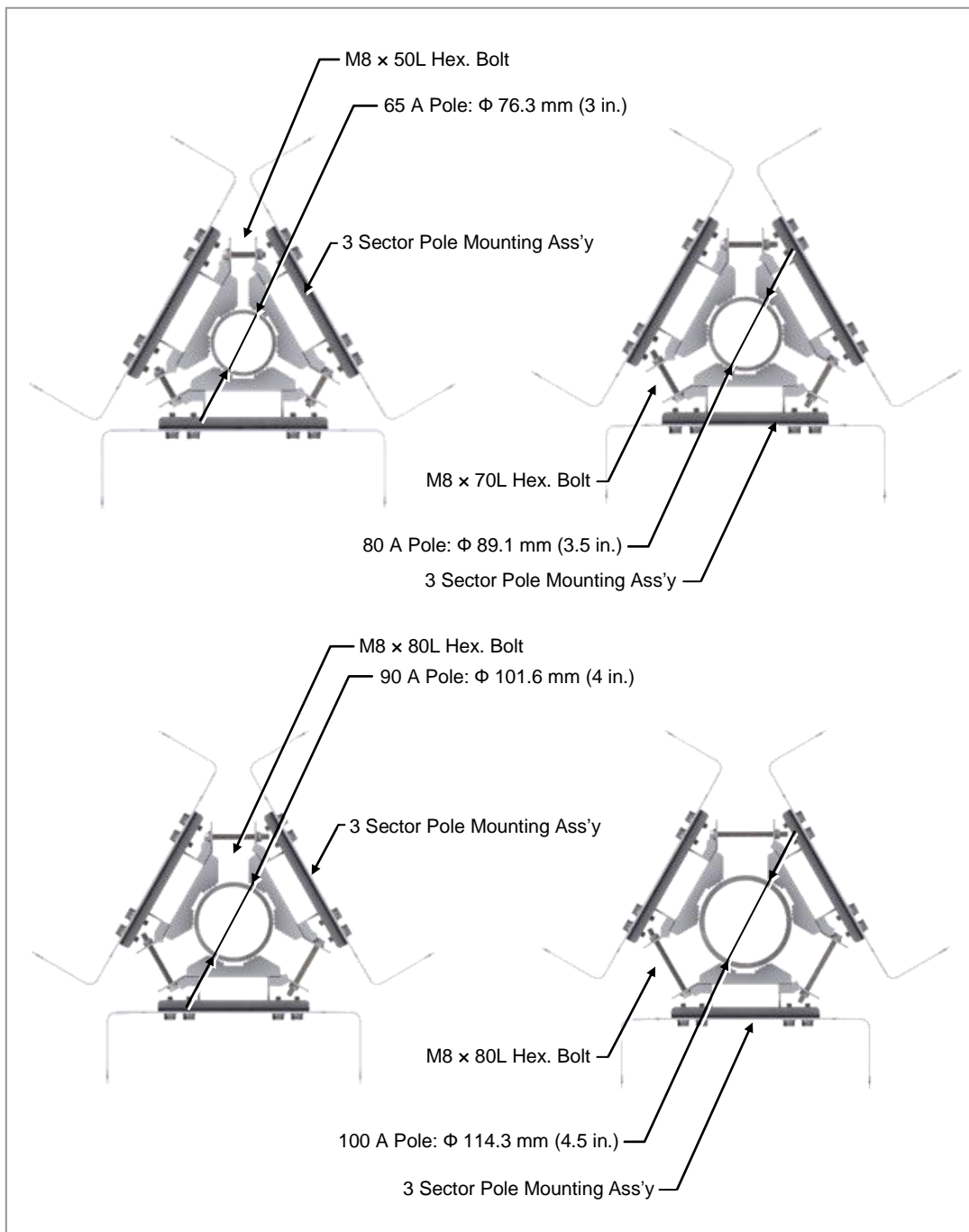

Figure 2.20 Bolt Specifications for 3 Sector Pole Type RRH-2WB-Examples

2.4.3 Fixing the Tower type RRH-2WB

Installing on the Tower

The following is an example of installing RRH-2WB, and a sector antenna to the tower:

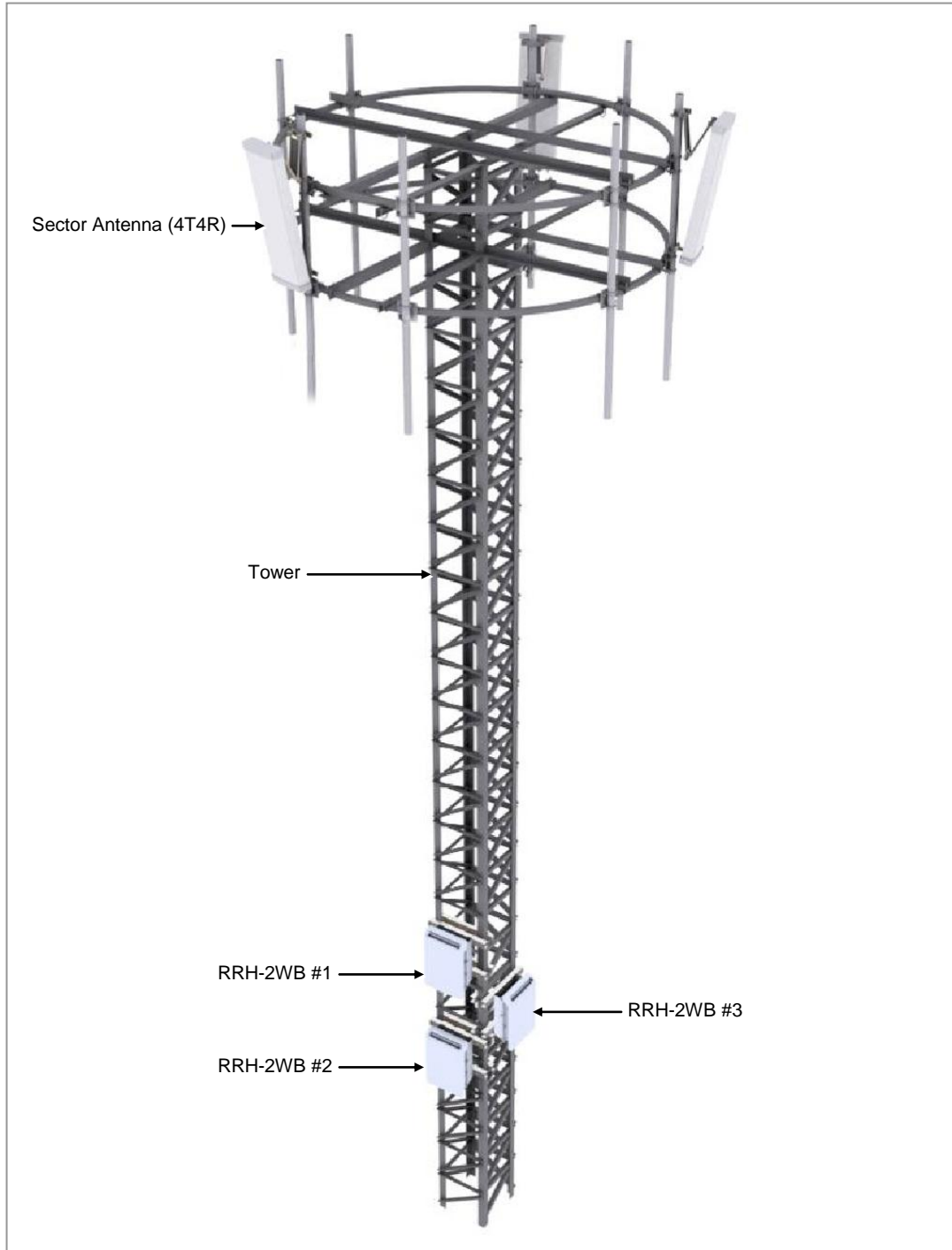

Figure 2.21 Example of Installing on the Tower

Fixing the Tower type RRH-2WB

Fix tower type RRH-2WB in the following steps.

1) Fixing the RRH-2WB Fixing Support to Tower

- a) Tighten the M8 stud bolts to the RRH-2WB fixing support (front side) fixing holes with plane washers, spring washers, and hex. nuts.

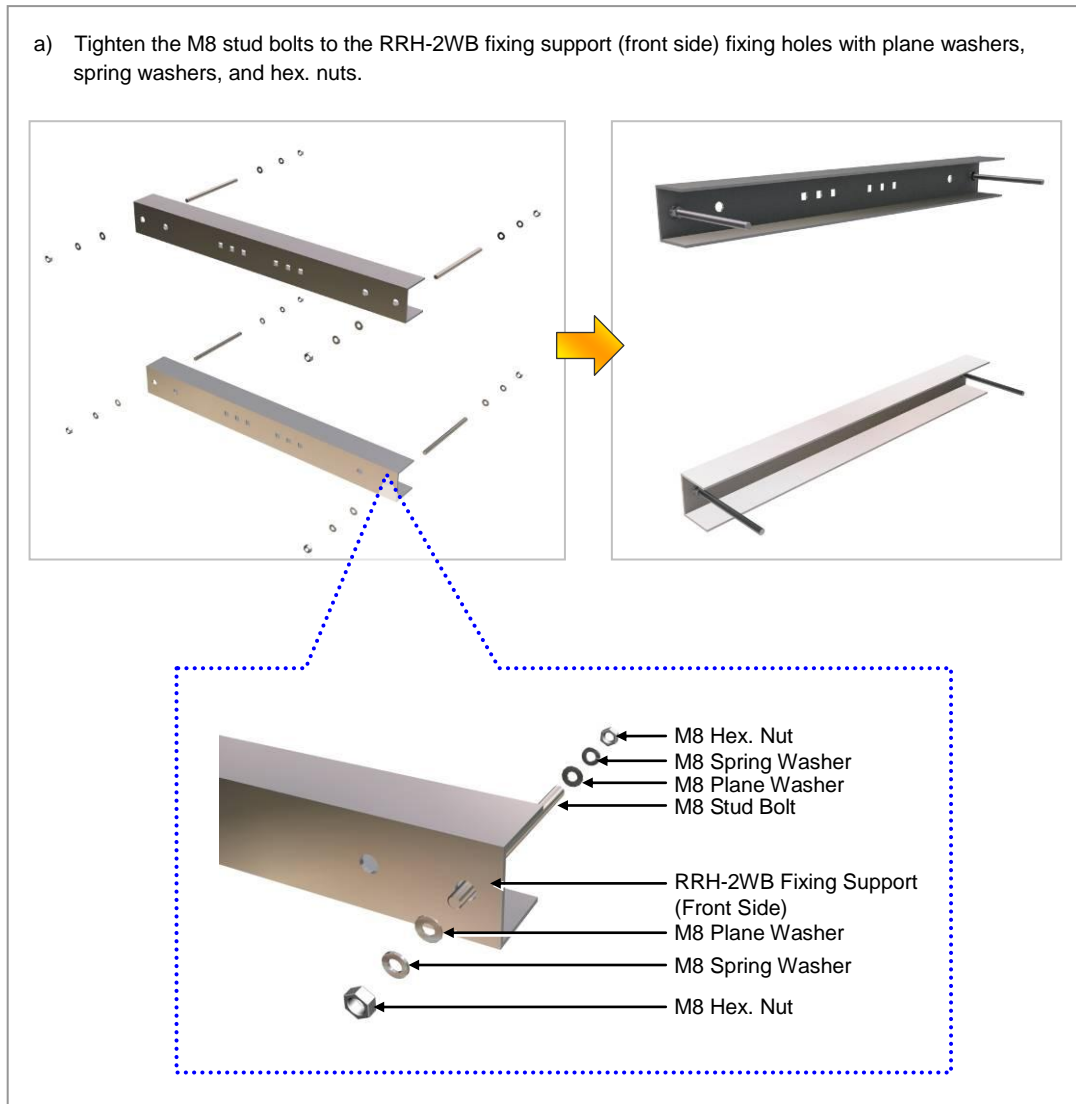

Figure 2.22 Fixing Tower Type RRH-2WB (1)

- b) Align the RRH-2WB fixing support (front side) outside of the tower and the RRH-2WB fixing support (rear side) inside of the tower with each M8 stud bolt and fixing hole, and tighten them with M8 plane washers, spring washers, and hex. nuts.

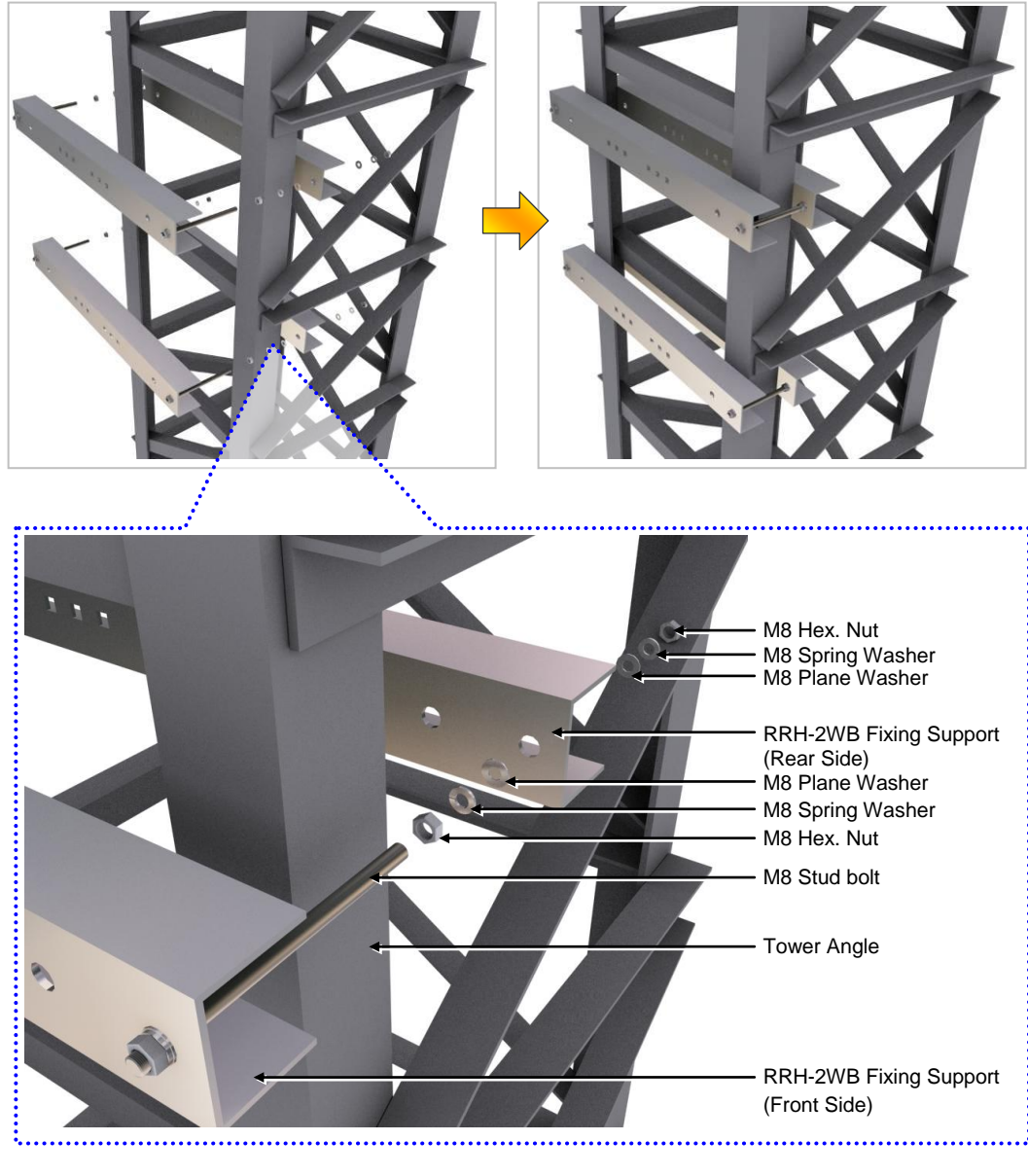

Figure 2.23 Fixing Tower Type RRH-2WB (2)

2) Fixing the RRH-2WB Unit Mounting Bracket to the RRH-2WB Fixing Support

Tighten the RRH-2WB unit mounting bracket to the RRH-2WB fixing supports with the M8 carriage bolts, plane washers, spring washers, and hex. nuts.

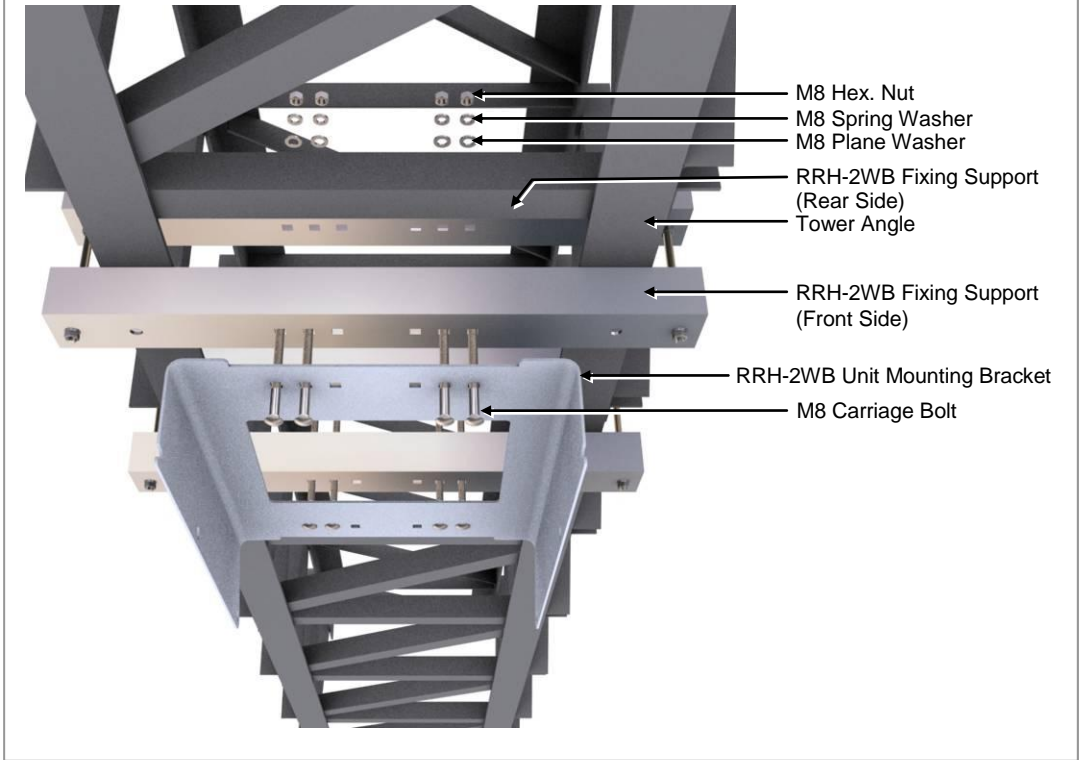

Figure 2.24 Fixing Tower Type RRH-2WB (3)

3) Fixing the RRH-2WB to the RRH-2WB Unit Mounting Bracket

Temporarily fix the M8 hex. bolt, plane washer, and spring washer loosely to the left/right fixing hole on the top of the RRH-2WB. Hang the RRH-2WB to the hooking holes at the top of the RRH-2WB unit mounting bracket. Then align the RRH-2WB with the fixing holes of the RRH-2WB unit mounting bracket and fix them firmly.

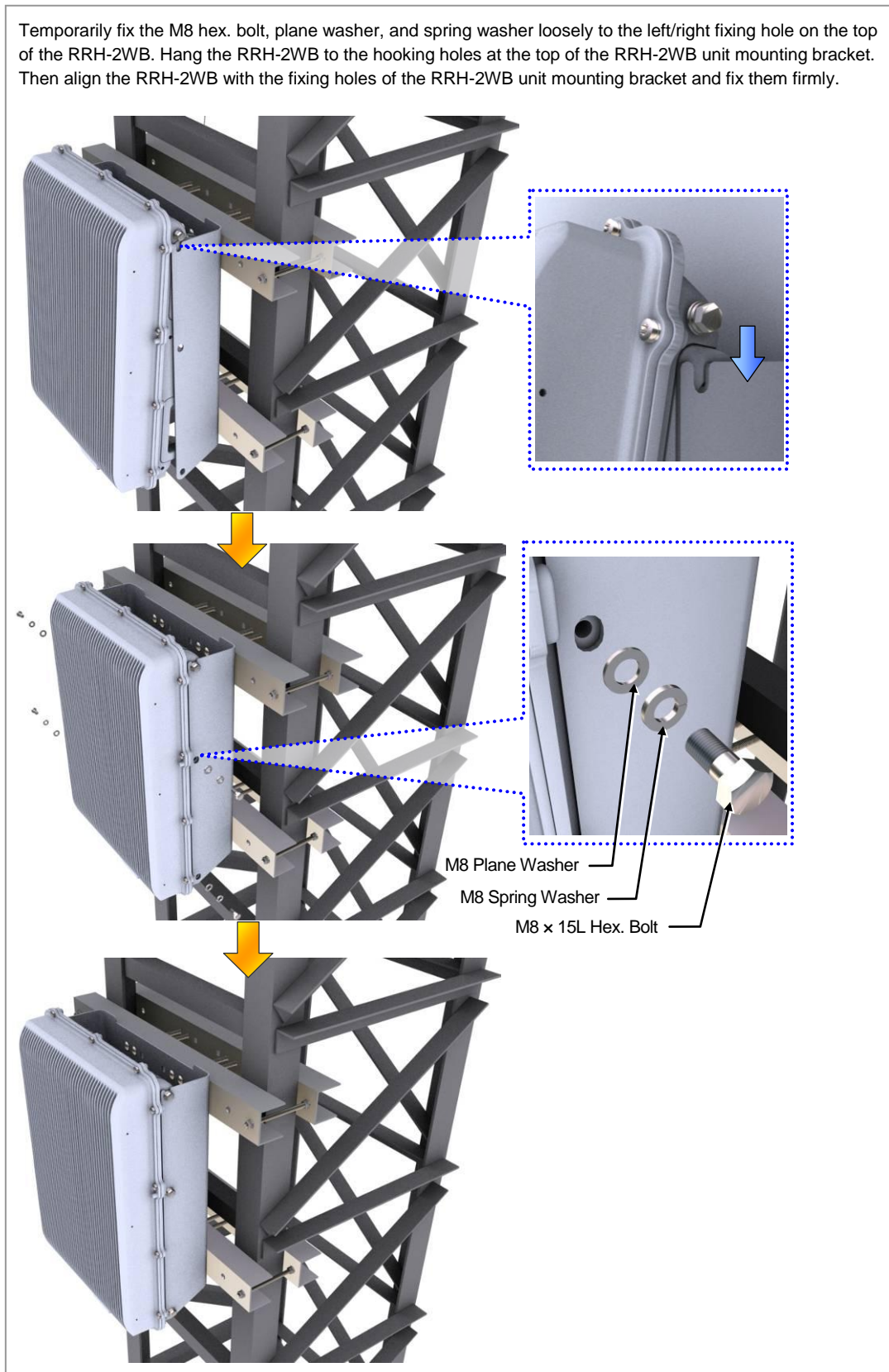

Figure 2.25 Fixing Tower Type RRH-2WB (4)

4) Assembling the Solar Shield to RRH-2WB

- a) Align the solar shield cover with the fixing holes of the RRH-2WB and then fix them firmly using M5 SEMS screws.

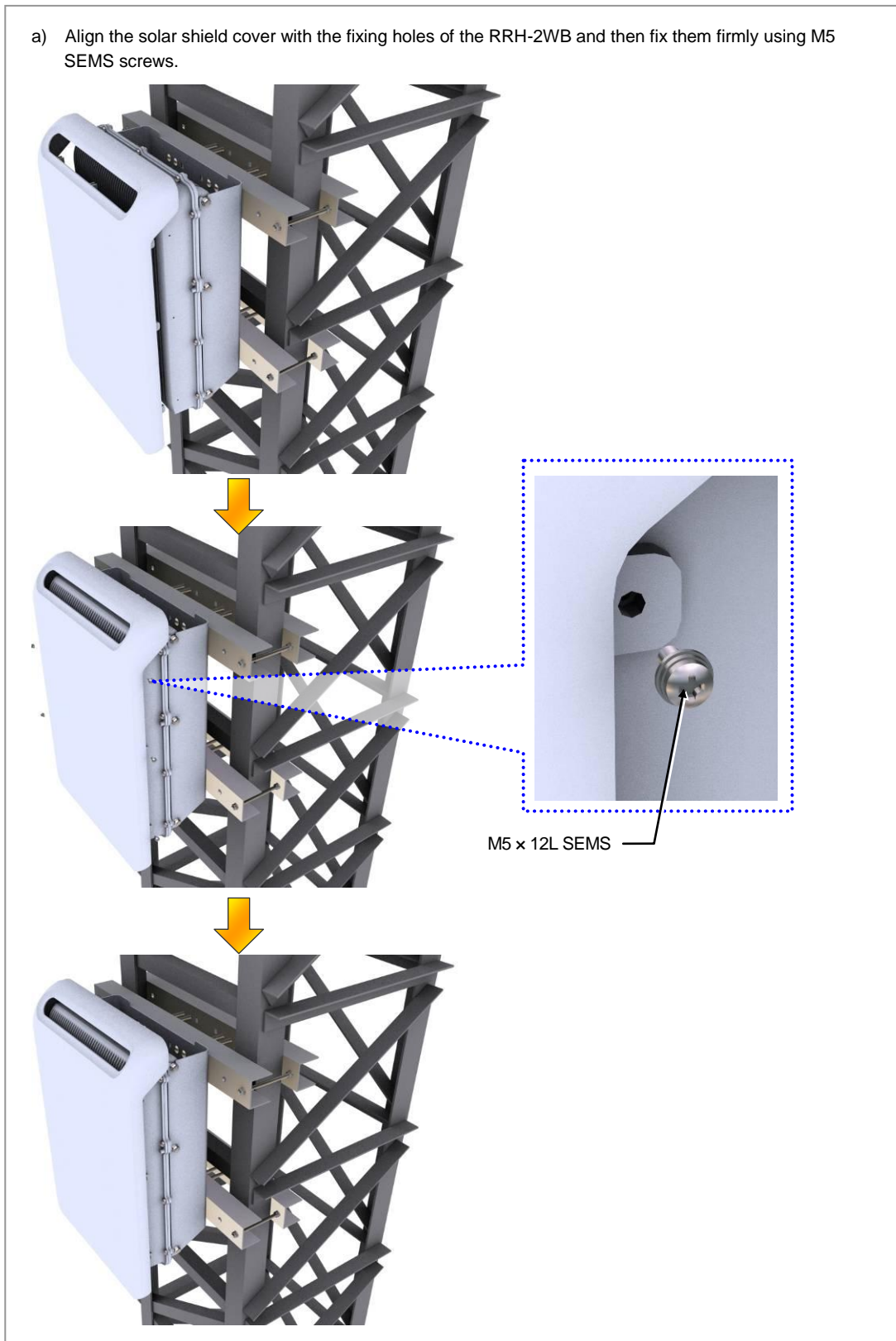

Figure 2.26 Fixing Tower Type RRH-2WB (5)

b) Attach RRH-2WB #1 and #2 to one side of the tower and RRH-2WB #3 to the other side

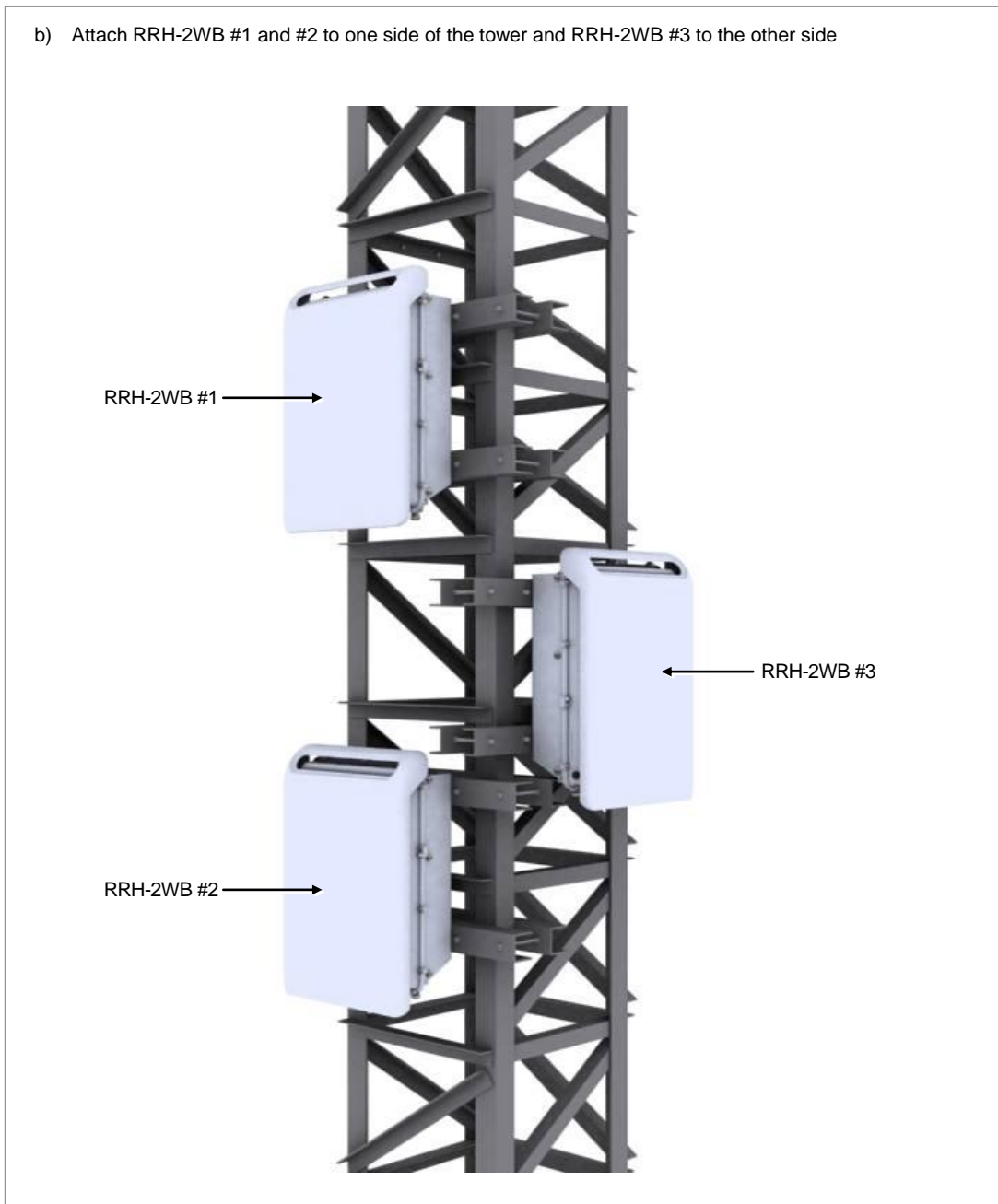

Figure 2.27 Fixing Tower Type RRH-2WB (6)

5) Fixing the Sector Antenna

- a) Place the pipe fixing plate and antenna fixing pipe in their positions and fix them to the platform pipe using M10 U-bolts.

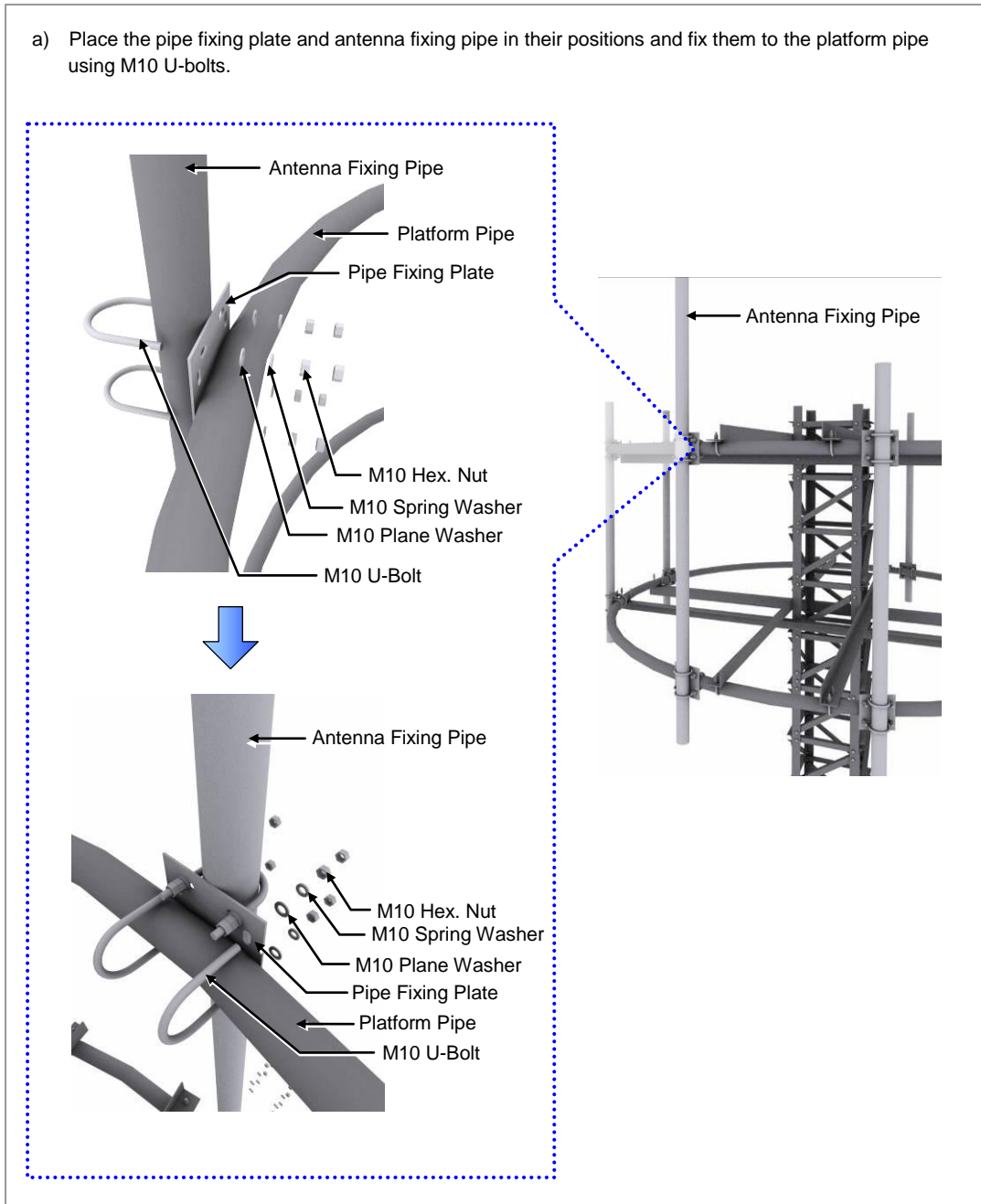

Figure 2.28 Fixing Tower Type RRH-2WB (7)

b) Install a sector antenna (4T4R) to each antenna fixing pipe.

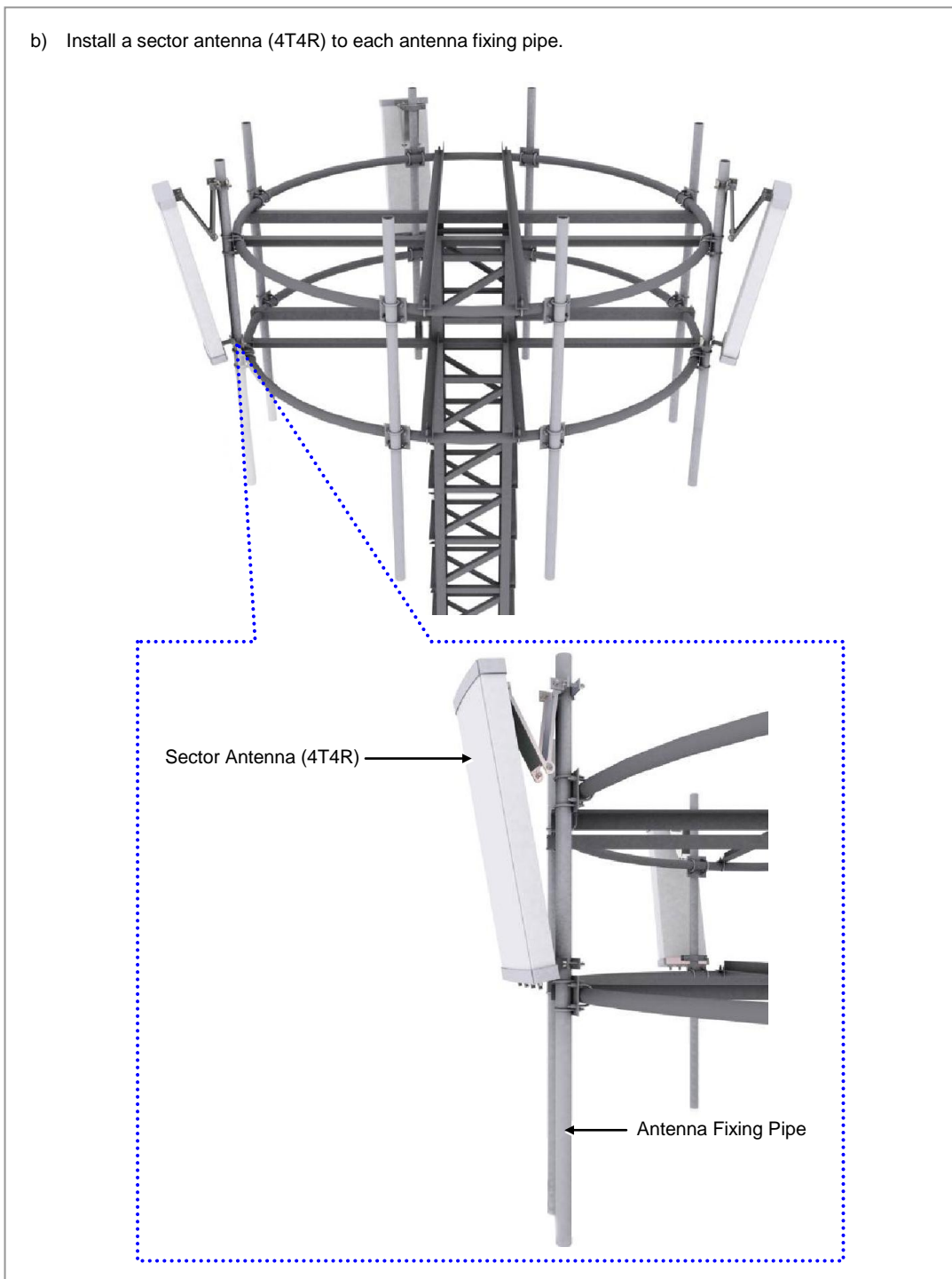

Figure 2.29 Fixing Tower Type RRH-2WB (8)

2.5 System Leveling

Leveling refers to compensating for the level difference on the floor that is generated during floor work to install devices horizontally or vertically. Leveling can be carried out using a vinyl hose, a balance weight, or a level.

However, levels are used for this system.

Leveling Using a Level

- 1) Attach a level to the top, left, and right of the system.
- 2) Adjust the system height so that the bubble in the level moves to the center of the window. (In the case of a digital level, the LCD should indicate an even plane.)
- 3) Leveling is complete when the bubble stays at the window center in every level.

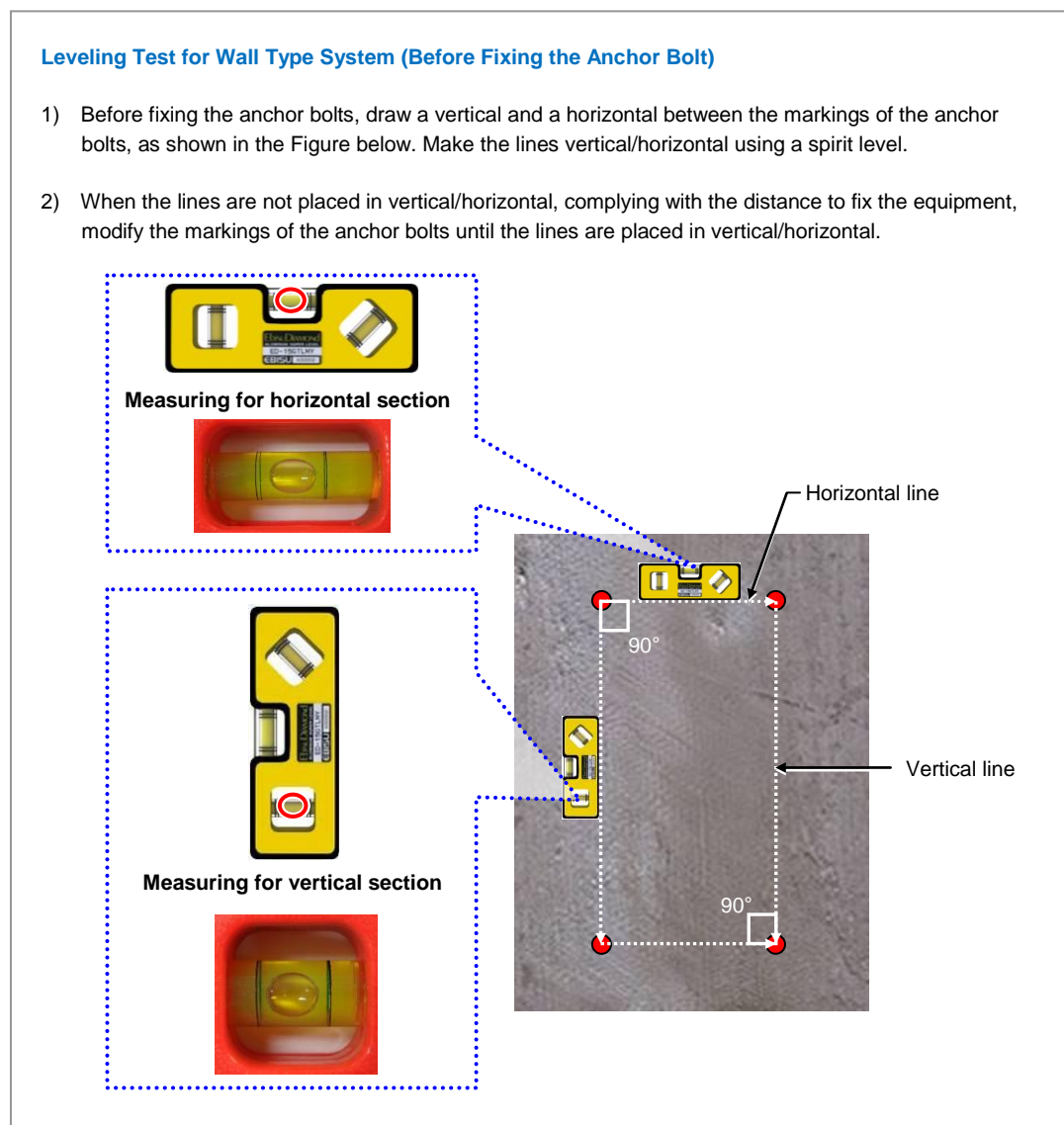

Figure 2.30 Leveling Test before Fixing Anchor Bolts

- 3) After fixing the equipment, place a spirit level on the side and top of the equipment, test the vertical/horizontal leveling.
- 4) If the leveling result shows that the equipment is not placed in vertical/horizontal, check and adjust the drilling location, connection materials' dimensions, and structures' dimensions and then make the

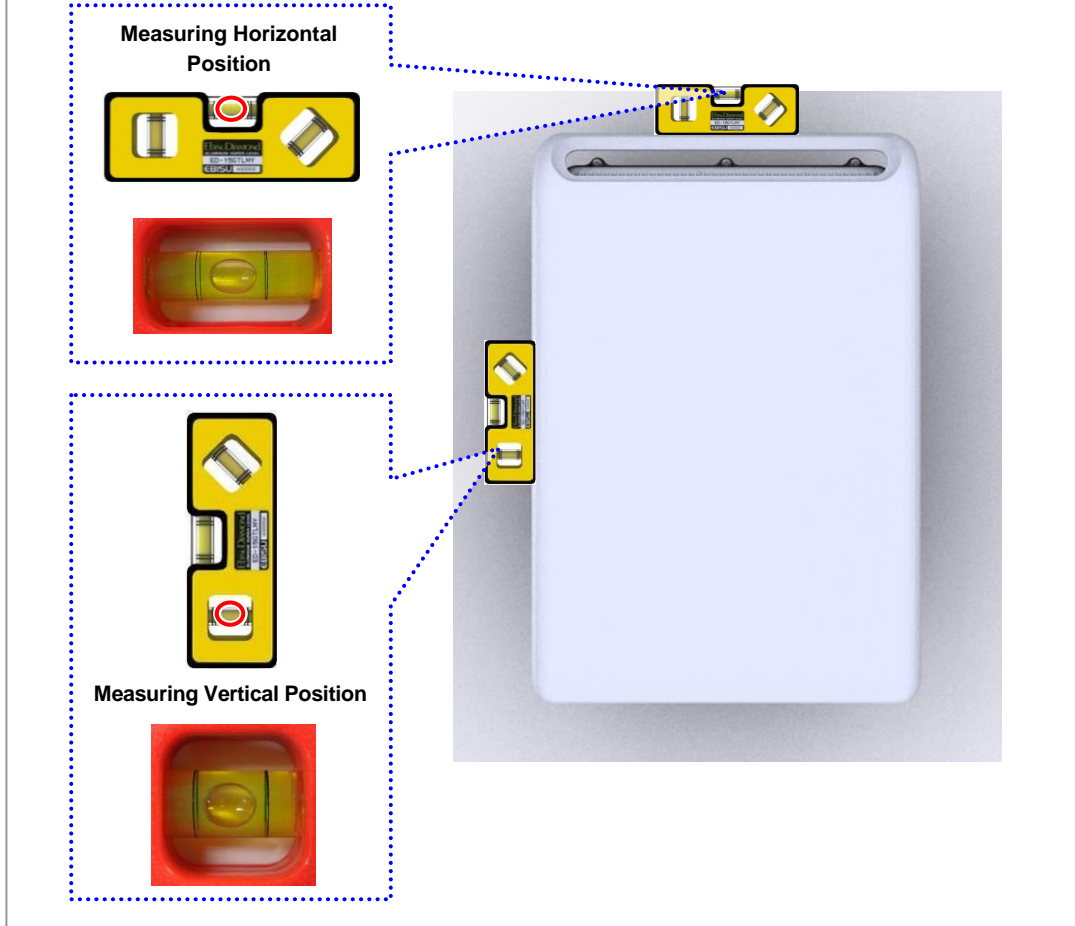

Figure 2.31 Leveling Test before Fixing System

2.6 Insulation Test

When conducting an insulation test, it is advised to set the insulation tester to DC 500 V and the insulation value is recommend as 100 MΩ or higher.

- 1) Connect a lead of an insulation tester to the Hex.bolt for fixing the RRH-2WB.
 - 2) Connect another lead to the anchor bolt.
 - 3) Measure the insulation resistance by using the insulation tester.
- The insulation resistance should be over 100 MΩ.

If the measured resistance is less than 100 MΩ, the value indicates the insulation failure. Thus, check the following and perform the insulation test again.

- Check if the connection between the Hex.bolt for fixing the RRH-2WB and the anchor bolt is proper. (Note that the anchor bolts must be shielded with an insulated bushing.)
- Check if the insulated bushing is damaged.
- Replace the insulator (insulated bushing, bakelite, rubber pad, etc.) or parts for fixing.

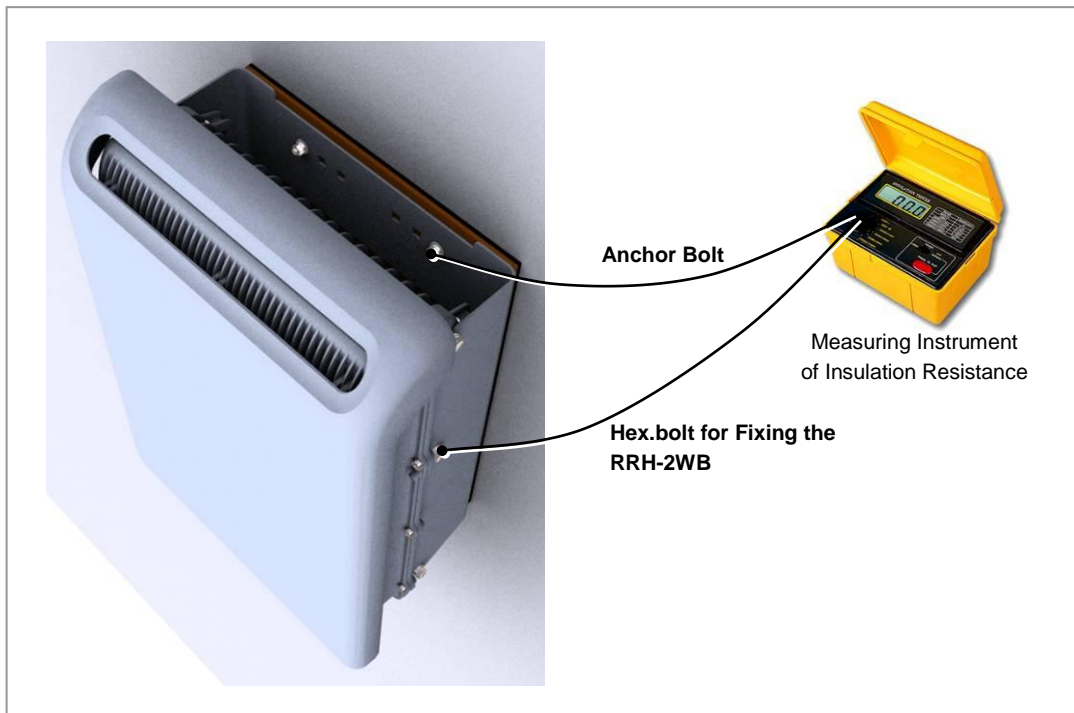

Figure 2.32 Schematic Diagram for Insulation Test



Precautions for Measuring Insulation Resistance

Since a high voltage is used for measuring insulation resistance, insulation resistance should not be measured when the system is in operation. Make sure to only measure the insulation resistance of the appointed part. Other components such as the system's internal components and the unit (system frame), components of the communication cables, units, etc. should not be measured.

CHAPTER 3. Connecting Cables

3.1 Work Flow for Cabling

The cabling sequence is as follows.

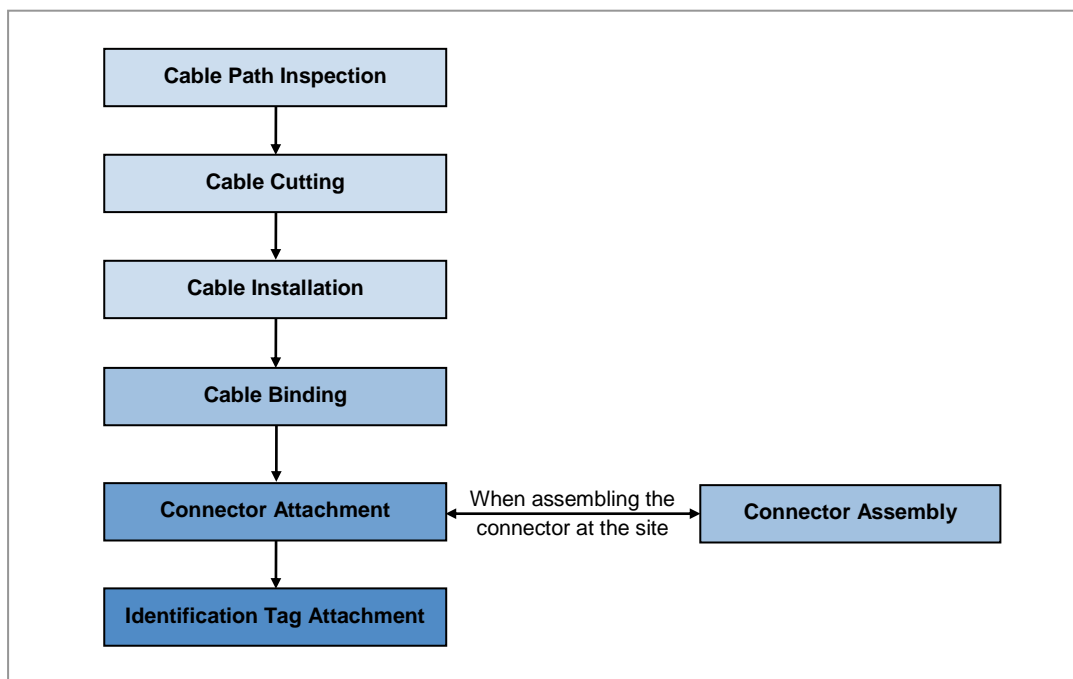

Figure 3.1 Work Flow for Cabling



NOTE

Cabling Workflow

The sequence of cable cutting and installation of the cable workflow can be changed depending on the field situation such as 'cutting after installing' or 'installing after cutting'.



CAUTION

Considerations when Cutting the Cable after Installation

When cutting the cable after installation, make sure that the connector is disconnected. Installation of the cable with the connector connected to the system may cause contact failure or damage to the connector assembled to the system and the cable due to cable tension or the operator's mistakes.

Cable Path Inspection

When installing a cable that connects between the rectifier, Main Ground Bar (MGB), and backhaul device, etc. within the system, the cable path length and the cable installation method, etc. must be inspected.

Follow these guidelines when inspecting the cabling path.

- A minimum cable length must be selected provided that it does not affect the cable installation and maintenance.
- The cable must be placed in a location where it will not be damaged by external factors. (power line, flooding, footpaths, etc.)
- In areas where the cable may be damaged by external factors, ensure that measures are taken to prevent damage to the cable. (cable tray, ducts, flexible pipe, etc.)

Cable Cutting

Measure the exact distance, carefully checking the route, and cut the cable using a cutting tool.

Follow these guidelines when cutting the cable.

- Cut the cable to the length determined in the Cable Path Inspection step.
- Use a dedicated cable cutting tool.
- Cut the cable at right angles.
- Be careful to keep the cable away from any moisture, iron, lead, dust or other foreign material when cutting. Remove any foreign material attached to the cable using solvent and a brush.

Cable Installation

Cable installation involves running the cable along the cabling path to the target connector of the system or an auxiliary device after cable path inspection and cable cutting have been completed.

Follow these guidelines when installing a cable.

- Be careful not to damage the cable.
- If the cable is damaged, cut out the damaged section before installing.
- When installing the cable over other cables, make sure the cable is installed on the other cables. Pay more attention to the vertical and horizontal cross sections where the cables are usually reversed.
- Always use the maximum curvature radius possible, and make sure that the minimum curvature radius specification is complied with.
- If the cable needs to be protected, use a PVC channel, spiral sleeve, flexible pipe, and cable rack, etc.

Table 3.1 Recommended Minimum Allowed Cable Bend Radius

No	Type	Recommended Minimum Allowed Cable Bend Radius	Remark
1	GV/CV/FR-8	8 times of the cable external diameter	0.6/1 KV Cable
2	Optic Cable	20 times of the cable external diameter	-
3	UTP/FTP/S-FTP Cable	4 times of the cable external diameter	PVC/LSZH, 4 Pair
4	1/2 in. Feeder Line (Indoor)	32 mm (1.26 in.)	RFS, LS
5	1/2 in. Feeder Line (Outdoor)	125 mm (4.92 in.)	RFS, LS
6	7/8 in. Feeder Line (Outdoor)	250 mm (9.84 in.)	RFS, LS
7	1-1/4 in. Feeder Line (Outdoor)	380 mm (14.96 in.)	RFS, LS
8	1-5/8 in. Feeder Line (Outdoor)	500 mm (19.69 in.)	RFS, LS
9	LMR-400	25.4 mm (1 in.)	Installation
		101.6 mm (4 in.)	Repeated
10	RG-316D	15 mm (0.59 in.)	-

※ If the allowed cable bend radius is specified by the manufacturer, comply with the bend radius specified.

Cable Binding

Cable binding involves fixing and arranging an installed cable using binding strings, cable ties, binding lines, and ram clamps, etc.

Follow these guidelines when binding a cable.

- Be careful not to damage the cable during binding.
- Use appropriate cable binding tools according to the target location (indoor or outdoor, etc.) and the use of the cable (power supply cable, optical cable, feeder line, etc.).
- Do not let the cutting section of a cable tie and binding line, etc. be exposed to the outside. This may cause damage to cables or personal injury. Make sure that the cutting sections of cables are not exposed to the outside.
- If there is a danger that contact failure may occur in a connector connection due to tension, install the cable as short as possible.

Connector Attachment

Connector attachment involves assembling a connector to an installed cable or to a device on the site.

Follow these guidelines when attaching a connector.

- Make sure you are fully aware of the connector assembly method before assembling a connector. Assemble the connector in accordance with its pin map.
- Each connector has a hook to prevent its core positions from being changed. Check the corresponding grooves before connecting a connector to another connector.
- Trim the remaining string of any knot in a binding string so that the knot does not loosen.

- Use a heat shrink tube at a connector connection for cables that are installed outdoor, such as feeder lines, to prevent water leakage and corrosion from occurring at the part exposed to the outside.
- Connect each cable of the connector assembly in a straight line.
- Be careful when connecting a cable so that contact failure does not occur at a connector connection due to tension.

Identification Tag Attachment

Identification tag attachment involves attaching a marker cable tie, nameplate, and label, etc. to the both ends of a cable (connections to a connector) to identify its use and cabling path.



NOTE

Marker Cable Tie

On the marker cable tie, a label can be attached.
The appearance and specification may differ depending on the type and manufacturer.



Follow these guidelines when attaching an identification tag.

- When installing a cable outdoor, use relief engraving and coated labels, etc. to prevent the markings from being erased.
- Since the form and attachment method for identification tags are different for each provider, consult with the provider before attaching them.



WARNING

Connecting Ground Cable

In cabling, the connection of cables without the connection to the ground cable may cause the damage of the equipment or the bodily injury of the worker. Connect the ground cable first.



CAUTION

Cable Work Sequence

When performing cable work for the system, proceed with the ground work before any other work to prevent errors occurring due to static electricity and other reasons.



CHECK

Cable Installation Checklist

When installing, take care not to overlap or tangle the cables; also, consider future expansion. Install the DC power cable and data transmission cable away from the AC power cable to prevent electromagnetic induction.



NOTE

Cable Works

The cable works require the knowledge for the cabling works such as cable installation/tying.

3.2 Cabling

The cabling diagram of the RRH-2WB is as follows:

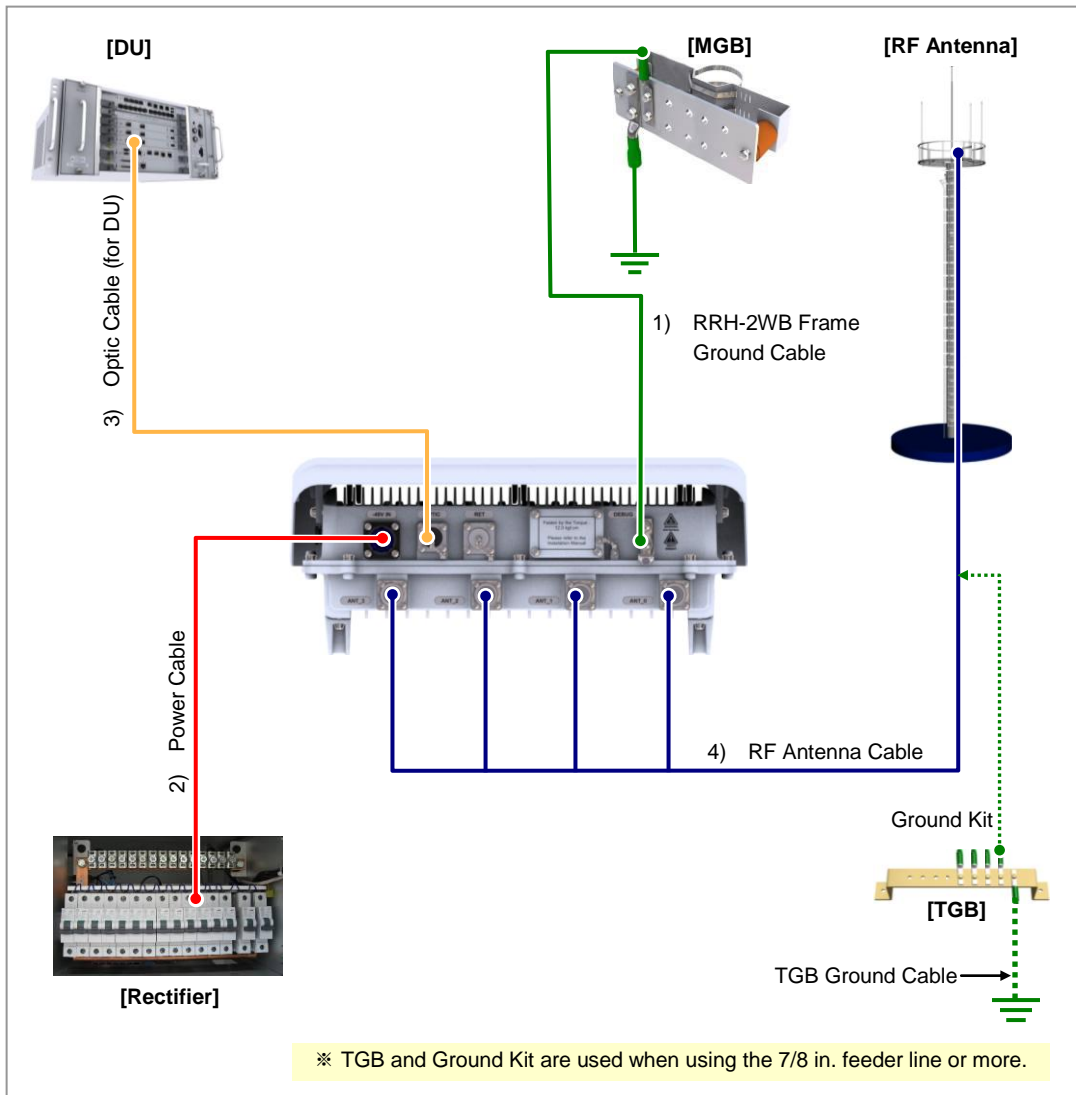

Figure 3.2 Cabling Diagram

Table 3.2 RRH-2WB Connecting Cable

From	To	Cable
RRH-2WB	MGB	1) RRH-2WB Frame Ground Cable : AWG 10, GV 4 mm ² × 1C
	Rectifier	2) Power Cable : AWG8, CV 6 mm ² × 2C
	DU	3) Optic Cable : ODC-4 to LC/PC, Single Mode
	RF Antenna	4) RF Antenna Cable : 1/2 in. Feeder Line, 7/8 in. Feeder Line
Underground ground	MGB	AWG4/0, GV 95 mm ² × 1C (However, this can be different, depending on the standard of service provider)
	TGB	AWG4/0, GV 95 mm ² × 1C (However, this can be different, depending on the standard of service provider)

3.3 Grounding

Grounding is required for protecting complex electronic or electric systems such as power system, communication system, and control system from lightning, over-current, over-voltage, and electric noise. Thus, the systems can operate properly and protect human life from electrical shock. Ground equipment minimizes the electrical potential of the electronic device to that of the ground, which is zero electrical potential, so that it can prevent the device from occurring electrification.

- The purposes of the ground construction are as follows:
- To prevent human life and the system from over-current, over-voltage, and lightning
- To provide a discharge path for surge voltage generated by lightning and power switch
- To protect the system from static electricity
- To eliminate or minimize the high-frequency potential in the system housing
- To provide a conductor for the balance and stability of high-frequency current
- To stabilize the potential of the circuit against the ground



Connecting Ground Cable

In cabling, the connection of cables without the connection to the ground cable may cause the damage of the equipment or the bodily injury of the worker. Connect the ground cable first.

3.3.1 Grounding the System

RRH-2WB Grounding

The way to connect the ground cable of RRH-2WB is as follows:

- 1) Install a ground cable (AWG10, GV 4 mm² × 1C) from the MGB to the ground terminal at the bottom of the RRH-2WB.
- 2) Fix a 4 mm² pressure terminal and a heat shrink tube at the cable end.
 - Pressure terminal: 2 Hole, 90°, hole diameter: 6.3 mm (0.25 in.), hole distance 16 mm (0.63 in.)
 - Heat shrink tube: Green
- 3) Align the pressure terminal fixed to the cable with the fixing holes on the RRH-2WB's grounding terminal, and fix it with M6 SEMS. Apply a torque of 20~30 kgf.cm (1.45~ 2.17 lbf·ft).

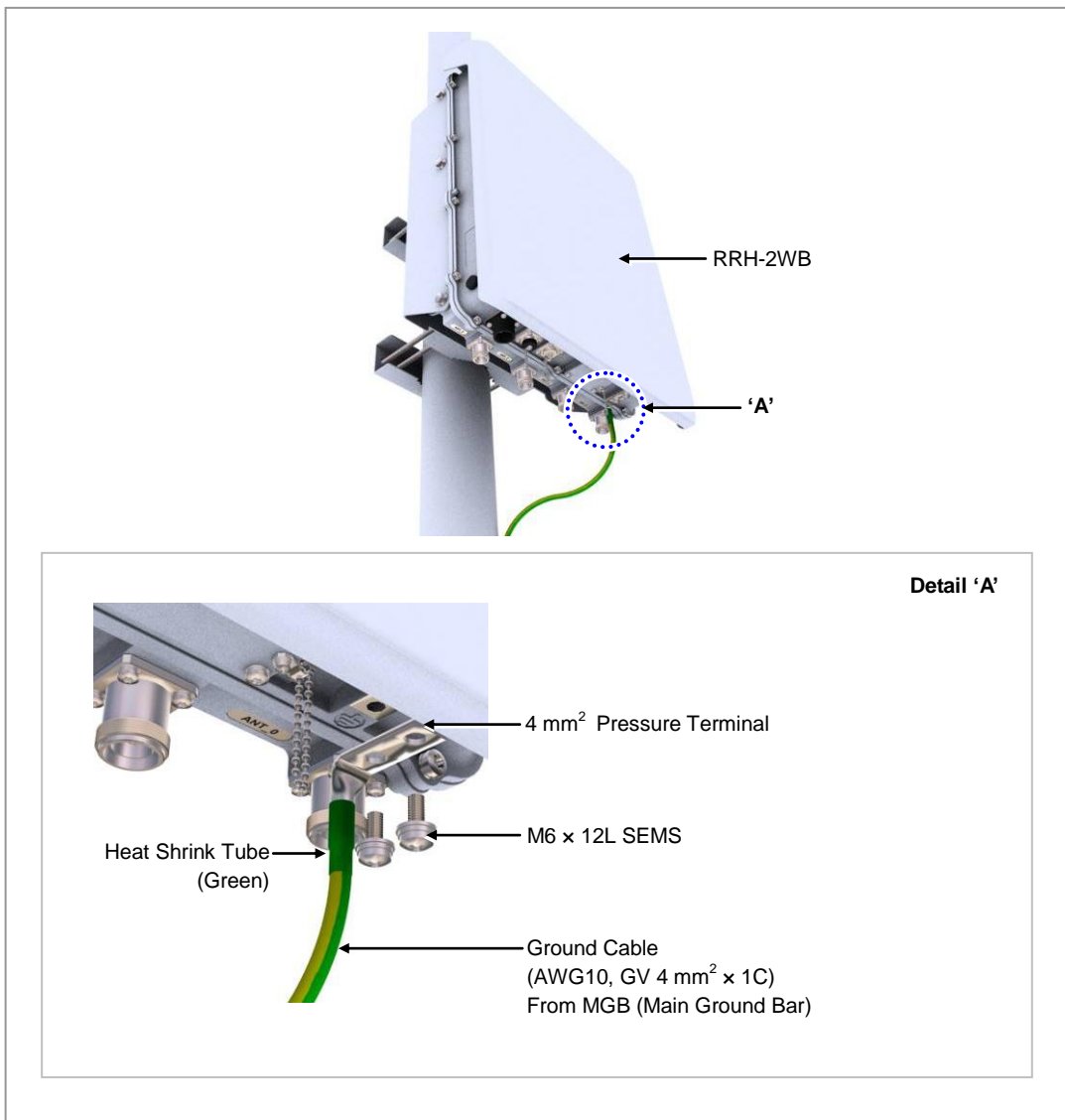

Figure 3.3 Connection of the RRH-2WB Ground Cable



CHECK

Pressure Terminal for RRH-2WB Frame Grounding

As for the pressure terminal or the cable, the UL certified products or equivalent should be used.

Ex) Manufacturer-Panduit

4 mm² Pressure Terminal: LCD10-14AF-L

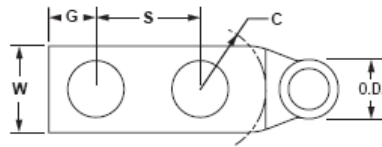

When connecting the pressure terminal to a cable, remove the cable sheath where the pressure terminal is connected, and then push the cable all the way to the end of the cable lead-in part.

Check the position of the coaxial cable through the inspection window of the pressure terminal before compressing it with a compressor.

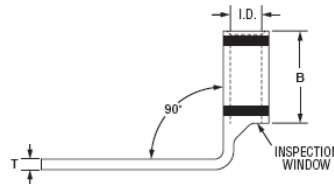

3.4 Power Construction

The power construction is to supply the power inside the exchange. The power supply device is configured as follows:

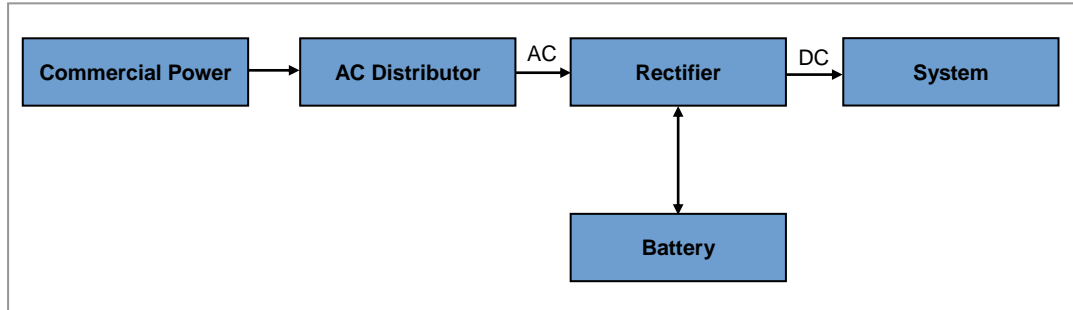

Figure 3.4 Power Equipment Diagram



Handling the Power Cable

- Handling the power cable incorrectly may damage the rack or cause an electric shock through the cable. Ensure the power switch on the rectifier or the system is turned off before handling the power cable.
- The fixing materials for power cable must be tightly secured to prevent electrical accidents.

3.4.1 Installing the Power Cable

- 1) Install a power cable (AWG8, CV 6 mm² × 2C) covered with flexible pipes from the rectifier to the power port at the bottom of the RRH-2WB.
- 2) Fit a water-proof power connector to the installed power cable (AWG8, CV 6 mm² × 2C). Refer to the assembly manual enclosed in the connector box for how to assemble the connector.
- 3) Fit a cut heat shrink tube to the power cable before connecting the cable to the system power port.
- 4) Connect the cable fitted with the power connector to the power port at the bottom of the system.
- 5) When the cable connection is completed, contract the heat shrink tube (jelly type) using a heating gun so that the flexible pipes and the connector unit are well fixed. (Finish using silicon if necessary.)

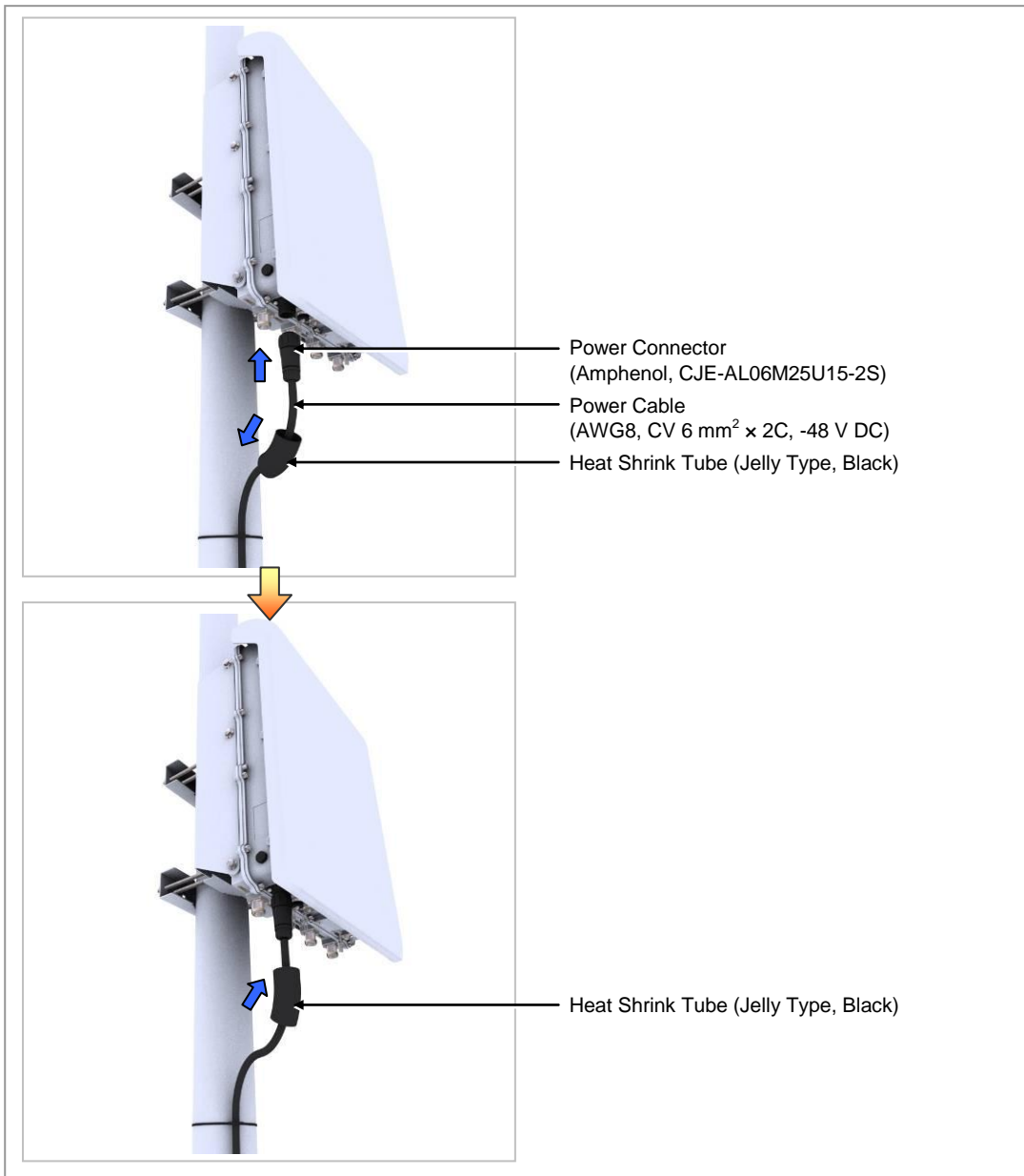

Figure 3.5 Installing the RRH-2WB Power Cable (1)

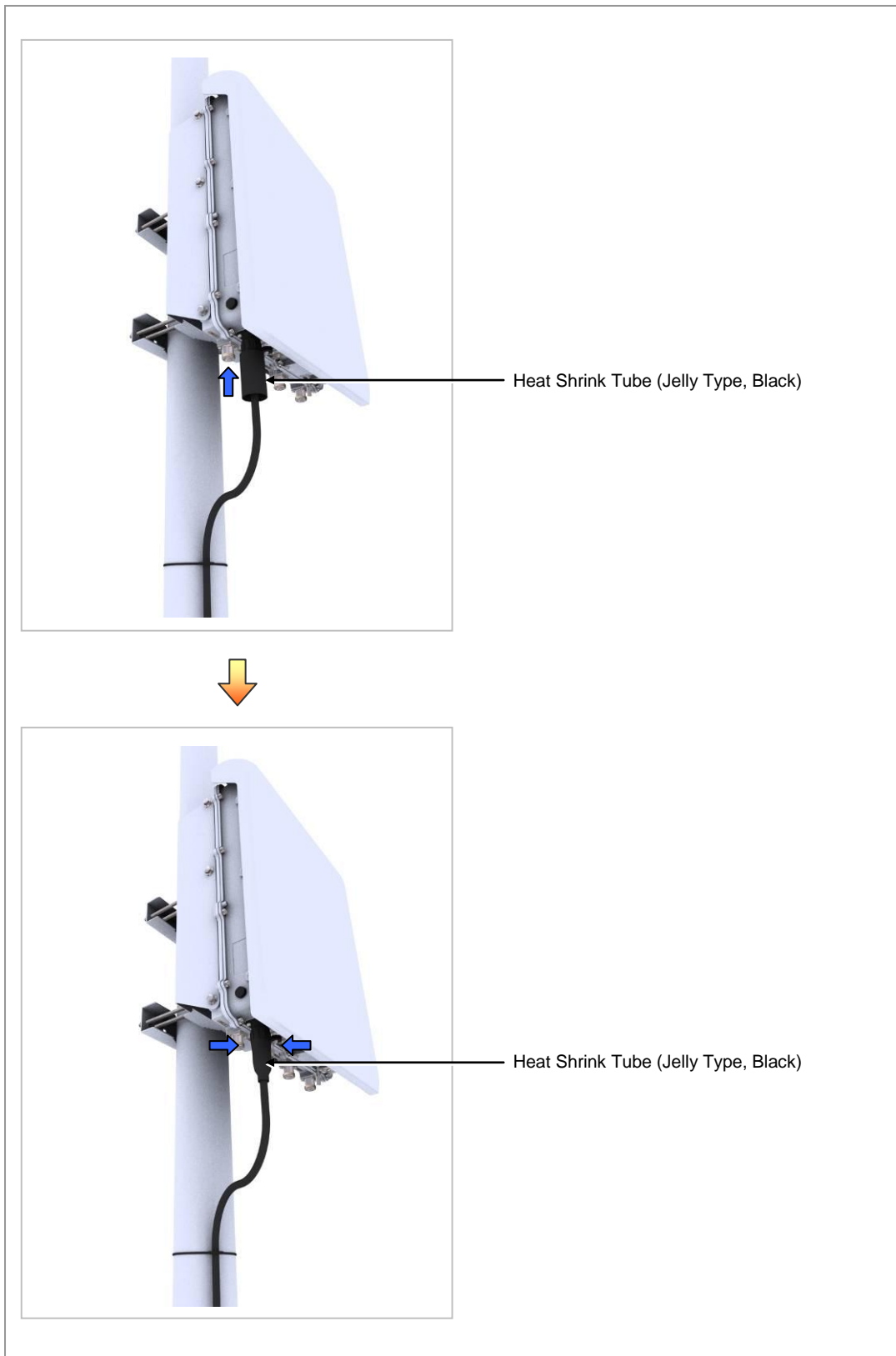

Figure 3.6 Installing the RRH-2WB Power Cable (2)



CHECK

Circuit Breaker Installation

Circuit breaker of slow blow type should be installed to the power line which is connected from the rectifier (or power distributor) to the system in order to supply the power stably. The capacity of -48 VDC circuit breaker is 20 A.



CAUTION

Power cable

In case of using AWG8 (6 mm² × 2C) power cable, it is applicable up to 70 m (299.66 ft). When the distance is 70 m (299.66 ft), followings should be considered.

- Do not rapid ON/OFF (within one second): The voltage loss value caused by the cable resistance loss is 3 V, and the RRH-2WB could be damaged by the counter electromotive force caused by the cable inductance.
- The battery's life could be shorten: The RRH-2WB could be off in spite the battery remains. (When the battery capacity is designed within one hour)
- Do not use the power cables linked: Using the power cables linked each other, the loss will be increased.

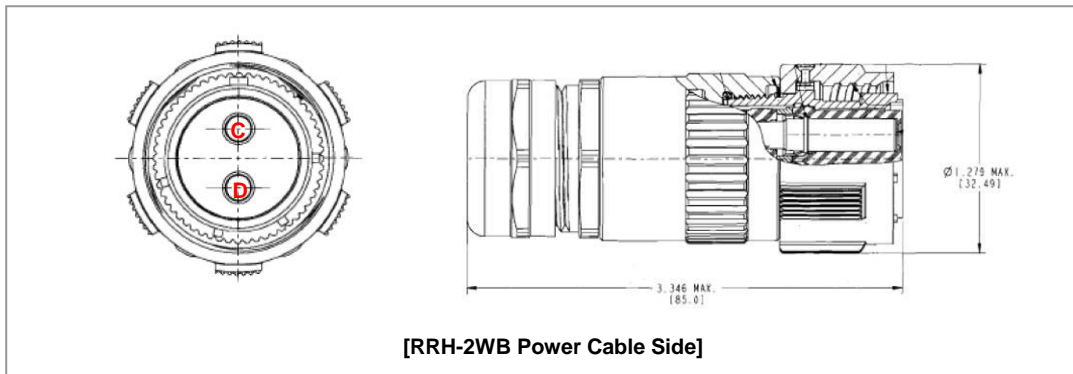

[RRH-2WB Power Cable Side]

Figure 3.7 Power Cable Connector

Table 3.3 Amphenol CJE-AL06M25U15-2S Power Connector Pin Map

Pin No.	Description	Power Cable Color (CV 6 mm ² × 2C)	Heat Shrink Tube Color
C	-48 V	Black	Blue
D	Return	White	Red



NOTE

Power Cable Color

In the table above, the cable color is based on the inner wire of the CV 6 mm² × 2 core cable. The color of the inner wires may vary depending on the type and manufacturer of the cable used.

3.5 External Interface Construction

3.5.1 Cable Connection between the DU and the RRH-2WB

The RRH-2WB is a unified RF module interfacing remotely with the DU through an optical cable. It is located at the front end of the antenna.

Cable connection between the DU and the RRH-2WB is as shown below.

- 1) Install an optic cable from the DU to the optic port at the bottom of the RRH-2WB.
- 2) Fit a cut heat shrink tube to the optic cable before connecting the cable to the system optic port.
- 3) Connect the optic cable connector (ODC type) to the optic port at the bottom of the system.
- 4) When the cable connection is completed, contract the heat shrink tube (jelly type) using a heating gun so that the flexible pipes and the connector unit are well fixed. (Finish using silicon if necessary.)

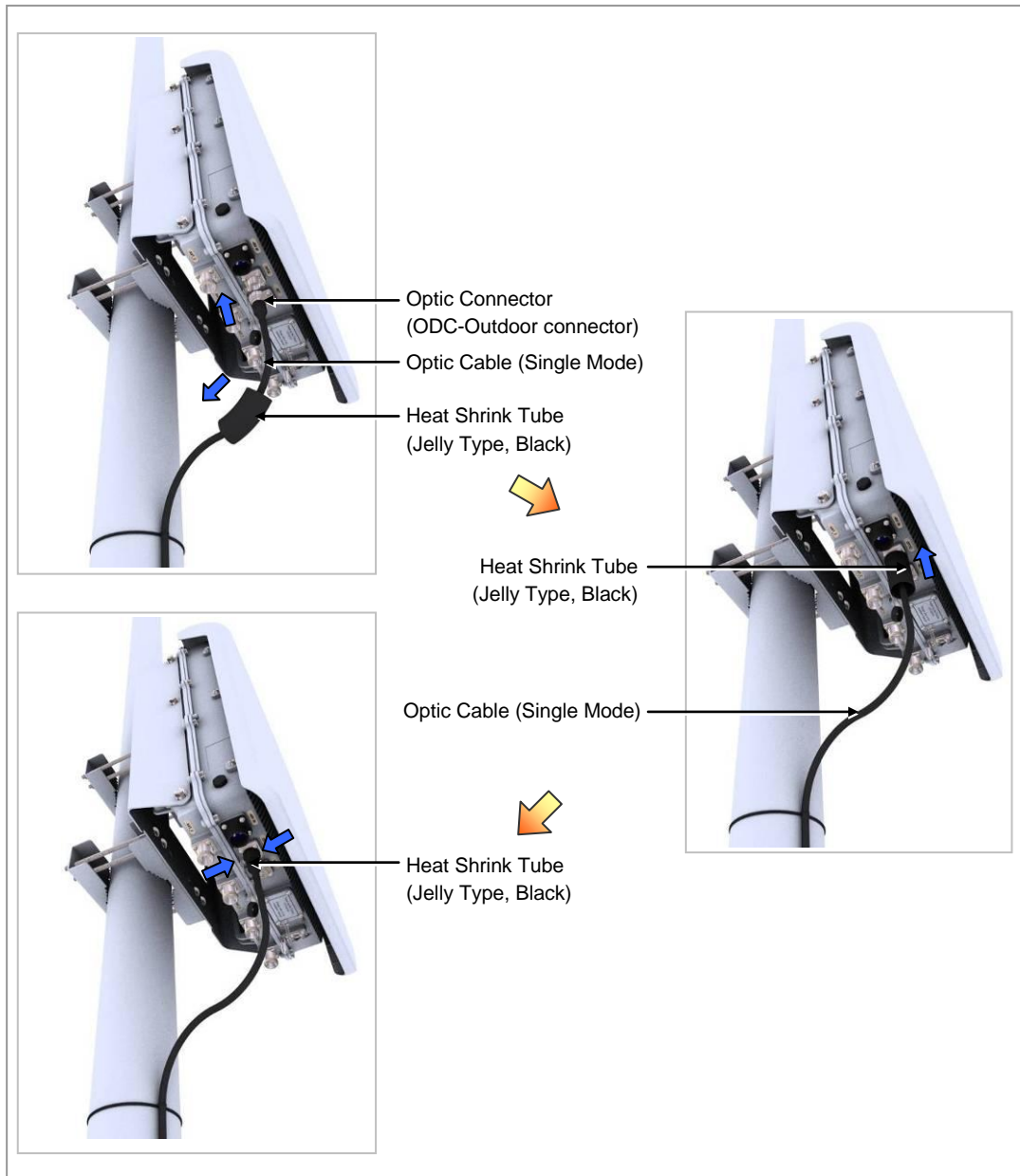

Figure 3.8 Cable connection between the DU and the RRH-2WB (Optical connection)

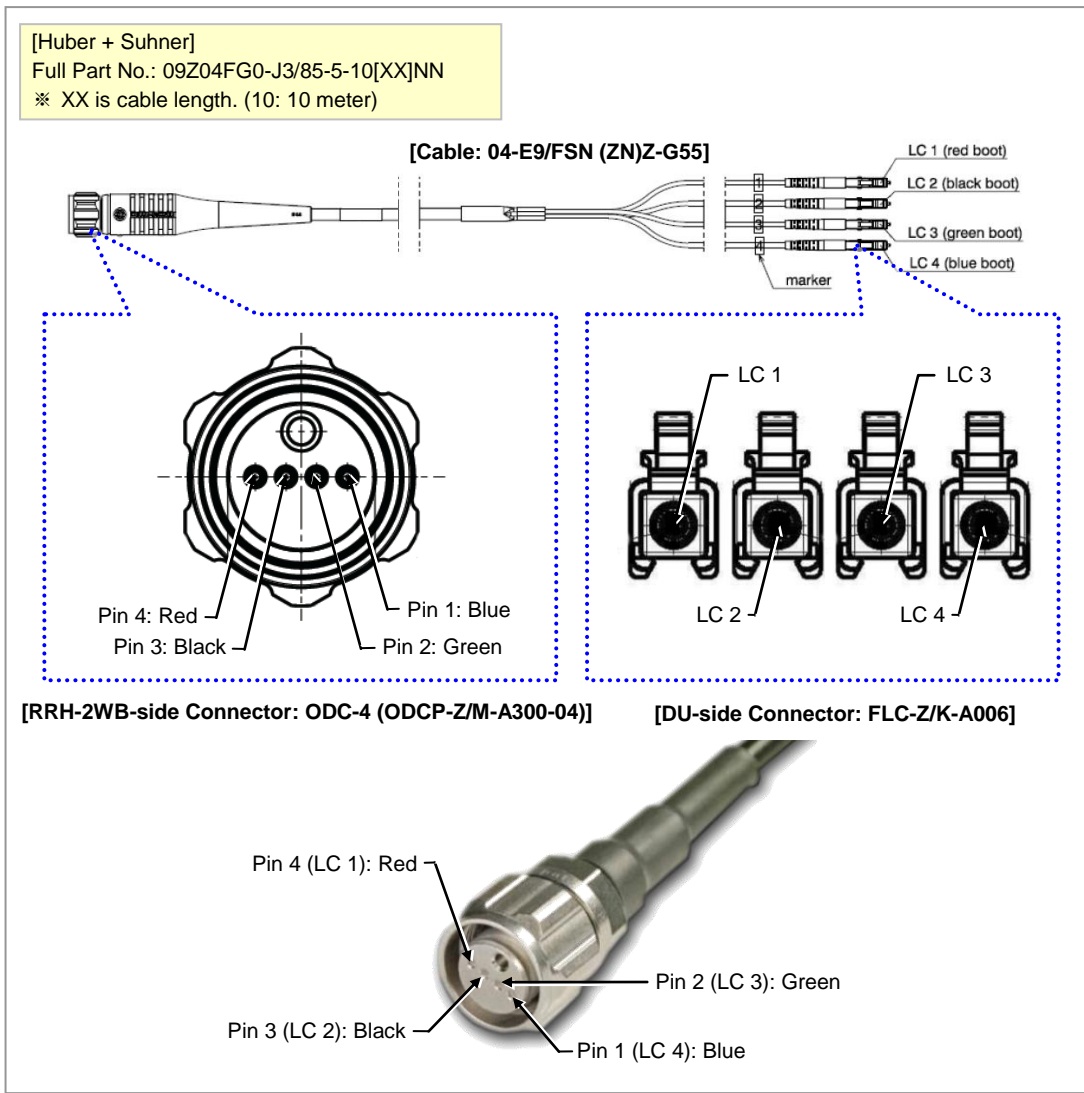

Figure 3.9 Optic Cable Connector between DU and RRH-2WB_RRH-2WB side

Mobile WiMAX Only Operation Mode (4T4R)

Optic cable between RRH-2WB and DU for Mobile WiMAX only operation mode is as follows:

Table 3.4 Cable Spec for Mobile WiMAX Only Operation Mode

Cable type	DU Side (LC)	
ODC-4 to LC Cable	For 1 st Carrier	
	Red	Green
	Primary	Secondary

Table 3.5 Optic Connector Pin Map between RRH-2WB and DU for Mobile WiMAX Only Operation Mode

DU Port		LC Connector Boot Color (Cable Marker)	RRH-2WB
MRA-F #0	L0	Red (LC1)	RRH-2WB #0
	L1	Black (LC2)	
MRA-F #1	L0	Red (LC1)	RRH-2WB #1
	L1	Black (LC2)	
MRA-F #2	L0	Red (LC1)	RRH-2WB #2
	L1	Black (LC2)	

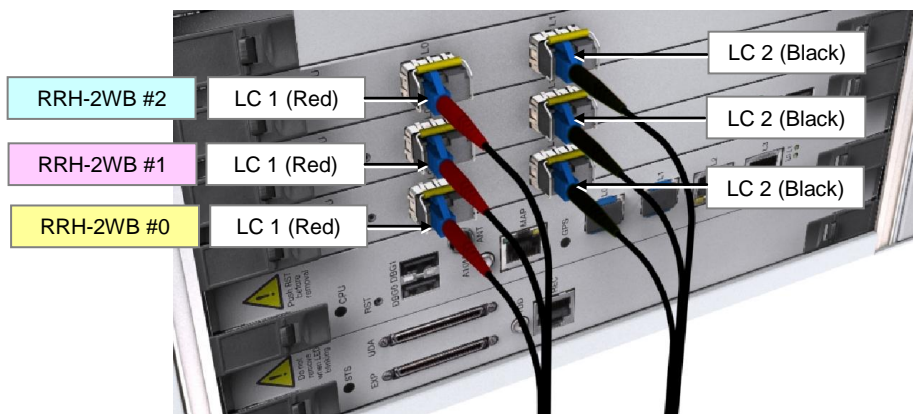
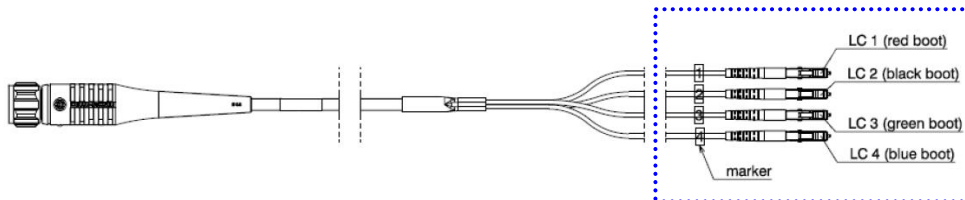

WiMAX + TD-LTE Dual Mode (2T2R)

Optic cable between RRH-2WB and DU for WIMAX + TD-LTE dual mode is as follows:

Table 3.6 Cable Spec for WIMAX + TD-LTE Dual Mode

Cable type	DU Side(LC)		
ODC-4 to LC Cable	WiMAX @ ANT0/ANT1		LTE @ ANT2/ANT3
	Red (LC1)	Green (LC3)	Blue (LC4)

Table 3.7 Optic Connector Pin Map between RRH-2WB and DU for WIMAX + TD-LTE Dual Mode

DU Port		LC Connector Boot Color (Cable Marker)	RRH-2WB
MRA-L	A0	Green (LC3)	RRH-2WB #0
	A1	Blue (LC4)	
MRA-F #0	L0	Red (LC1)	
MRA-L	B0	Green (LC3)	RRH-2WB #1
	B1	Blue (LC4)	
MRA-F #1	L0	Red (LC1)	
MRA-L	C0	Green (LC3)	RRH-2WB #2
	C1	Blue (LC4)	
MRA-F #2	L0	Red (LC1)	

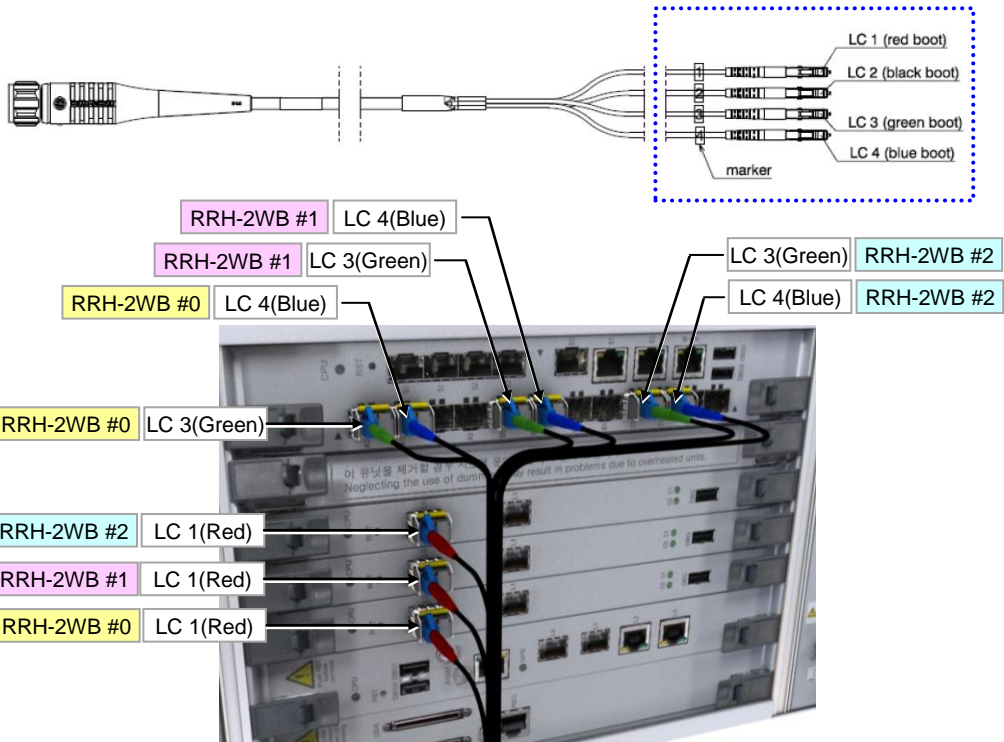

**Warning for Laser Beam Running through Optical Cables**

In the system, the laser beam emitting light runs through the optical cable. The exposure of the laser beam on worker's eye may cause serious injury so that it should be handled with care.

**Connecting the Optic Cable**

Before connecting the optical cable, check if the cutting section of the connector core is soiled. Be careful to keep the cutting section away from dust or foreign material. If the cable is soiled with foreign material, do not blow to remove them. Make sure to clean the connector in accordance with the cleaning directions for the optic cable. Refer the 'ANNEX D'.

3.5.2 Cable Connection of RET

Below is the method for connecting the Remote Electrical Tilting (RET) cable to control the antenna tilting angle remotely.



CHECK

RET

- When applying 27 VDC voltage, a current of 1 A or less must be supplied to the RET from the RRH-2WB.
- For the external material of the RET, metal without vent hole or the UL certificated material must be use.

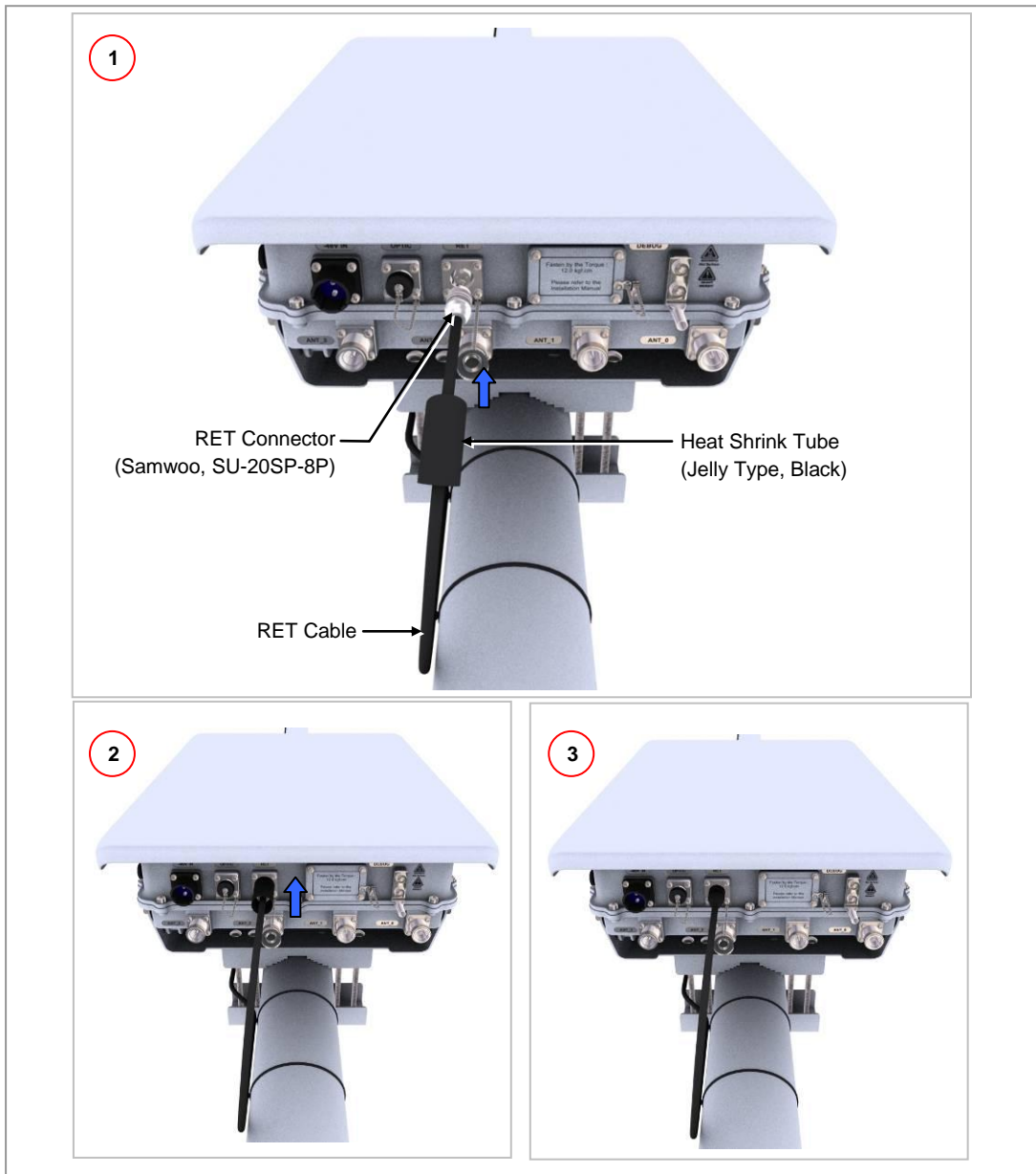

Figure 3.10 Cable Connection of RET

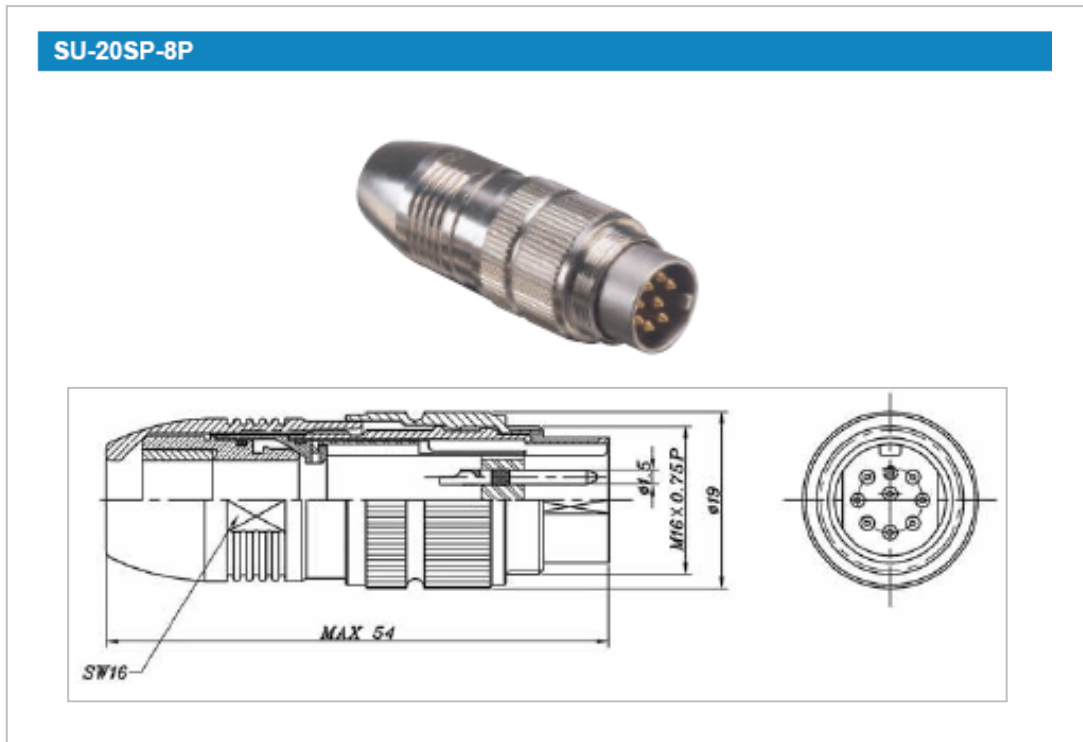

Figure 3.11 RET Cable Connector

Table 3.8 RET Cable-side Connector Pin Map

RET Connector	Samwoo, SU-20SP-8P	
	Pin	Function
	3	RS485B
	4	DGND
	5	RS485A
	6	+28 V
	7	+28 V RTN
	1, 2, 8	NC

3.5.3 Connection of Feeder Cable

Connect a feeder cable between the RRH-2WB and the sector antenna as follows.

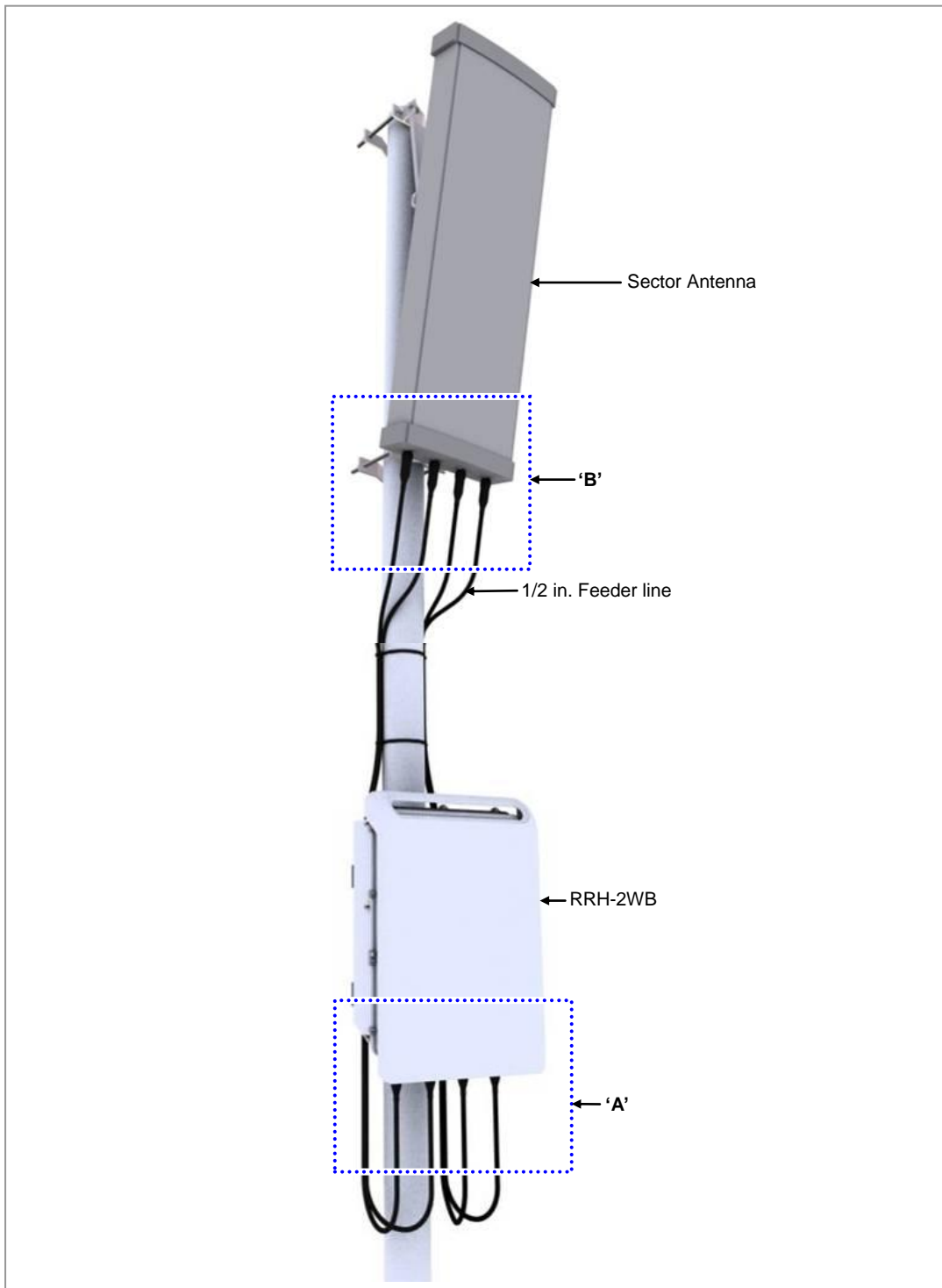

Figure 3.12 Feeder Line Connection Diagram

Detail 'A'

- 1) From the 1/2 in. jumper ass'y between RRH-2WB and the RF antenna 1/2 in. jumper ass'y, install one end of the cable, which the miniature Din-type male connector is connected to, to the RF port at the bottom of RRH-2WB.
- 2) Attach the heat shrink tube (jelly type) for finishing to the Jumper cable, and connect the miniature Din-type male connector to the RF port.
- 3) After connecting the connector, finish the connection with a heat shrink tube (jelly type).

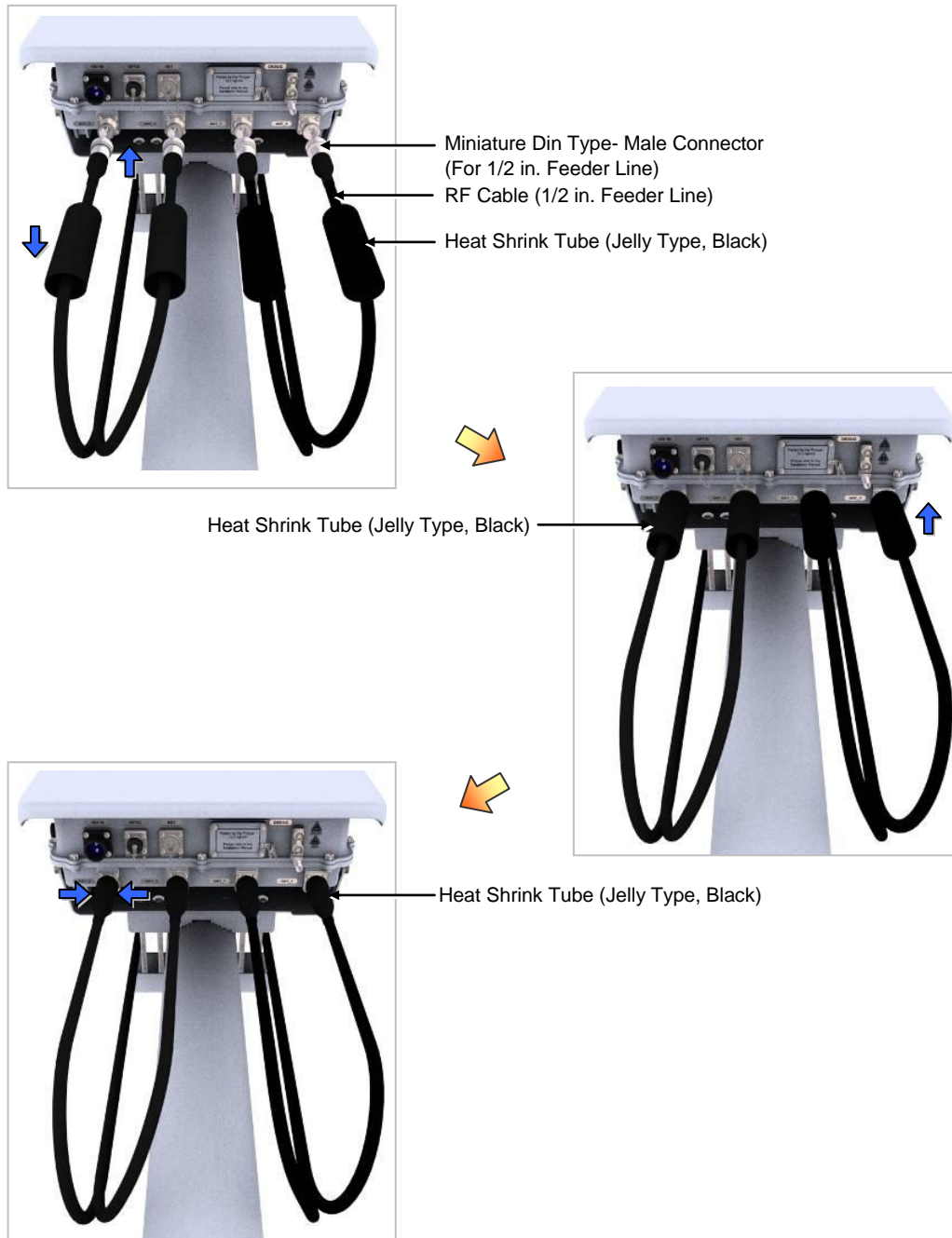

Figure 3.13 Connection of Feeder Cable (Detail A)

Detail 'B'

- 4) Attach the heat shrink tube (jelly type, black) for finishing to the other end of the 1/2 in. jumper ass'y connected to the RRH-2WB's RF port, and connect the N-type male connector to the sector antenna's port.
- 5) After connecting the connector, finish the connection with a heat shrink tube (jelly type, black).

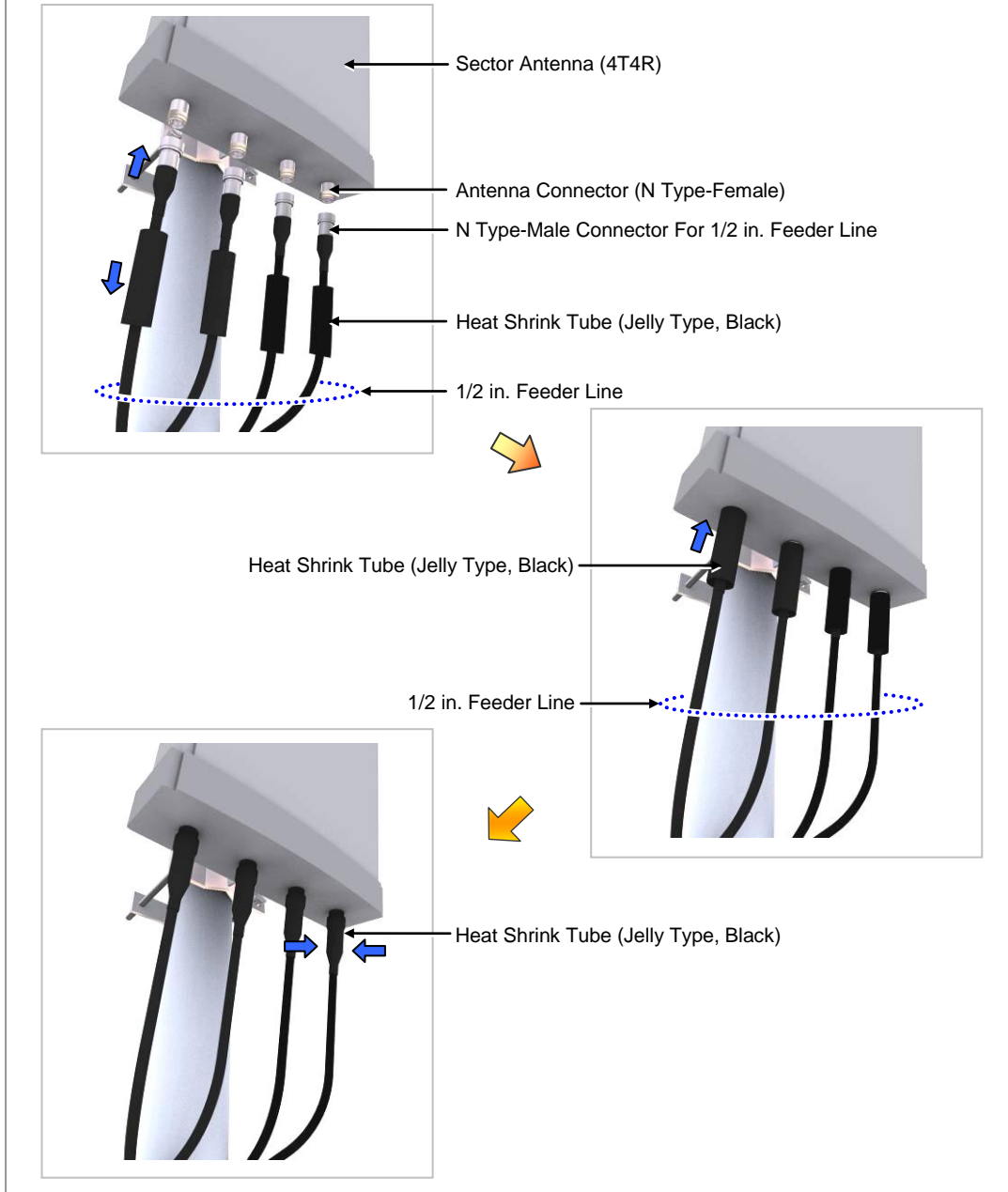

Figure 3.14 Connection of Feeder Cable (Detail B)

**CHECK****Checking the Antenna/Arrestor/Line Amplifier Connector Specs**

The connector specifications may differ depending on the supplier and the manufacturer of antenna/arrestor/line amplifier. Check the specifications of the antenna/arrestor/line amplifier before preparing materials. Even, the same kind of connectors may have different specifications depending on the cable, so check whether the connector can be applied to the cable to be used.

Ex) Din Type-Male: 1/2 in. for feeder line, 7/8 in. for feeder line

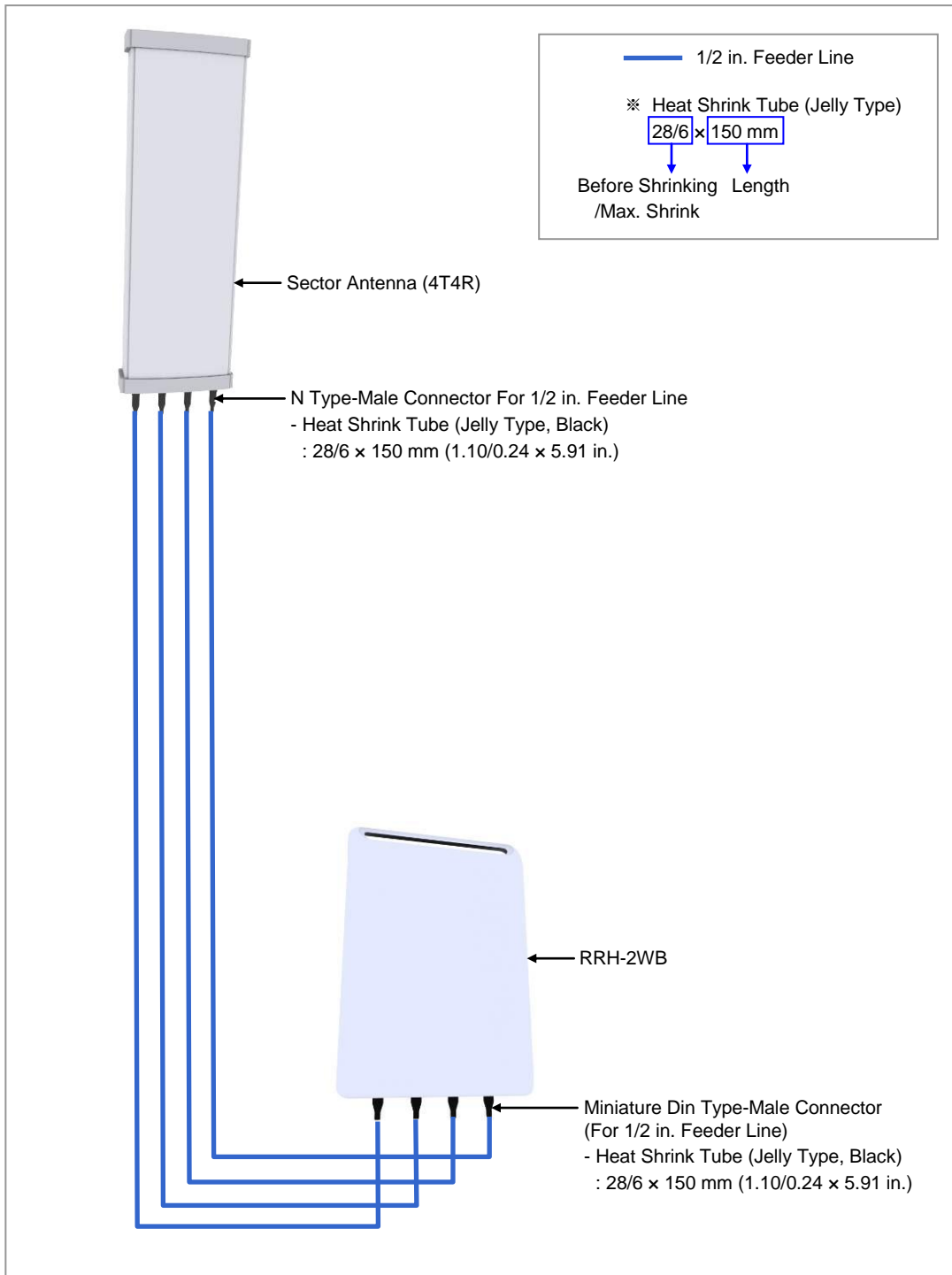
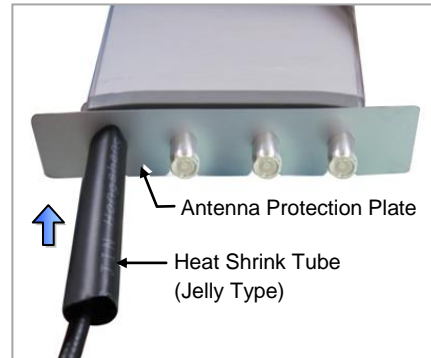
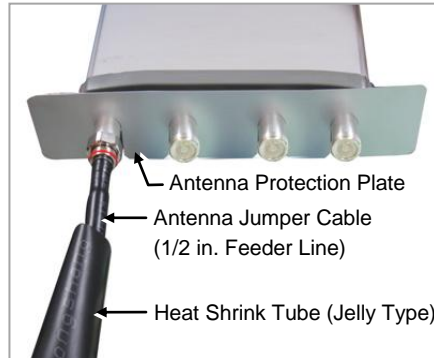

Figure 3.15 Heat Shrink Tube Specification

**CAUTION****Finishing Heat Shrink Tube of a Sector Antenna**

- 1) Insert an antenna protection plate to antenna port.
- 2) Place the heat shrink tube on the connection point and shrink the heat shrink tube using a heat gun.



Avoid aiming the heating gun toward the antenna's body as shown in the figure below.

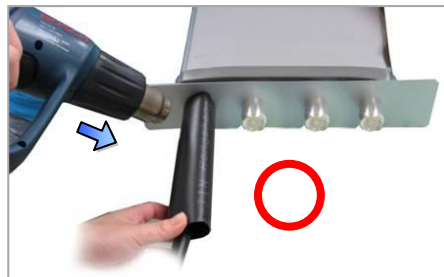

**CAUTION****Installing the Antenna**

When you install the antenna, the distant and angle between the antenna and lightning rod must be within the protective angle (left/right side 45° each from the central axis) to prevent the antenna from lightning damage.

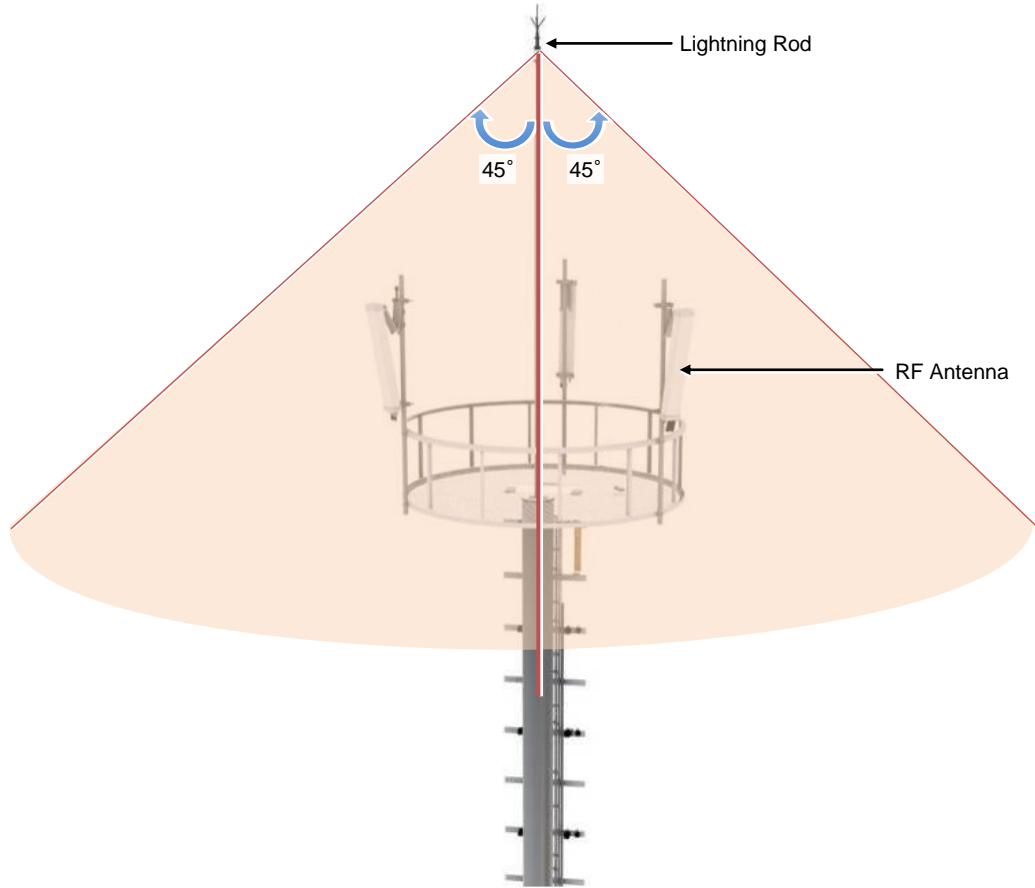

Checking Feeder Connection

After connecting the feeder cables, perform the continuity test and feeder cable return loss to check if the feeder cable is changed and measure VSWR of antenna and feeder cable.

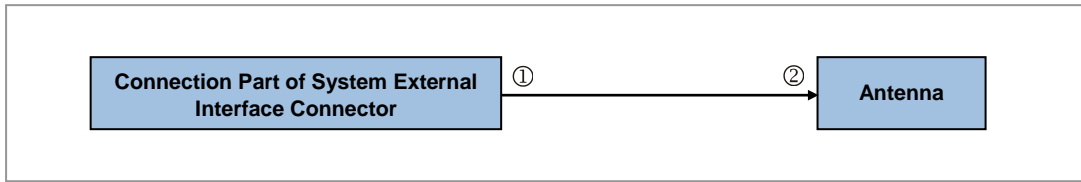

Measure all cables of section ①~②. The measured VSWR should be the specification value or less. If the VSWR exceeds the specification value, disassemble the connector and measure each section separately.



CAUTION

Checking VSWR for Minimum Cable Bend Radius and Length of RF Cable

If the VSWR value for minimum cable bend radius and length of RF cable is not applied, system may not work properly because RF signals cannot transmit or receive smoothly. So, the VSWR value for minimum cable bend radius and length of RF cable must be checked and applied.

RF Cable Identification Tag Installation

Attach the identification tape in the below table to the RF cable.

Table 3.9 RF Cable Identification Tag

Category	Description
Installation position	Attach the identification tag to the both ends of the antenna.
Materials	Use the material of aluminum coated by vinyl for the identification tag.
Fixing method	- Antenna side: Attach the tag to the feeder line using binding strings through the two holes on the tag. - Equipment Side: Cover up the feeder line with the tag and fix it using binding strings through the two holes on the tag.
Identification method	The markings must be prevented from being erased by using relief engraving or coated labels.

3.6 Installation Test

If the installation of the system is complete, progress the installation test to check the status of the system. If there is any problem, restore the system and write out the failure table.

Table 3.10 Construction Situation Checklist

Category	Check Items	Criteria	Result		Remarks
			Pass	Fail	
System Installation	System fixing status (vertical and horizontal)	Horizontal and vertical locations			
	System arrangement status	Horizontal and vertical locations			
	Locking status and standard compatibility of bolts/nuts/washers	Visual inspection and magnet test			
	External wiring and other wirings	Visual inspection for twist, array and arrangement			
	Cable installation between systems	Checking twist, distortion and installation status			
	External connector connection	Visual inspection to check poor contact (tightening status)			
	Other appurtenant work (Cable duct installation and others)	Visual inspection			
Power Acceptance	Equipment power line standards	Visual inspection			
	Power terminal panel ↔ System	Visual inspection			
	Cabling Status	Visual inspection for twisted or entangled status			
	Damage of cable sheath	Visual inspection			
	Connection status of system power connector	Visually inspect to ensure that the power connector is properly connected, and that there are no gaps or movement.			
	System input voltage (BATT voltage)	Measurement by digital meter (voltmeter)			
	Cabling status	Visual inspection (Flexible, Vinyl hose)			

Table 3.10 Construction Situation Checklist (Continued)

Category	Check Items	Criteria	Result		Remarks
			Pass	Fail	
Ground Construction	Ground line standard	Visual inspection			
	Ground bar ↔ System	Visual inspection			
	Ground line cabling status	Cabling status check			
	Termination treatment of the ground line (pressure terminal)	Visual inspection			
Feeder Line Status	Feeder line cabling and locking status	Beauty, robustness and Bending			
	ANT installation and attachment status	Visual inspection (ANT bar's vibration status)			
	Connection and finish status	Beauty and robustness			
Various TAG Status	Feeder tag	Visual inspection (Information mentioned: length, loss value, location)			
	Power cable tag	Visual inspection (Power Identification)			
	Ground table tag	Visual inspection			
	Attachment status of the label for the real-name construction system - Indoor: wall side of the gate side - Outdoor: inside of the cover of the distribution box	Visual inspection (size and material)			
Finish Status	Cable duct bolt's attachment status	Visual inspection			
	Feeder inlet finish treatment status	Visual inspection (check if the rear part is attached)			
	Status of inside/outside of the system and vicinity of the base station	Visual inspection			
General Opinion					



ANNEX A. Sector Antenna Installation

A.1 Cautions when Installing a Sector Antenna

Precautions of antenna installation are as follows.

- Sector antennas should be installed vertically. ($\pm 1^\circ$)
- Antenna is the precise material, so be careful not to make damage or form change.
- When moving antenna, use the tool suitable to rating. In addition, use the rated carrying device which is at least 200 % or more than antenna considering the stability.
- Be careful not to give too much strength to the antenna.
- If it rains, suspend connecting the feeder cable and antenna.
- Fix it after adjusting the direction of antenna exactly.
- Distance between steel tower and antenna and the distance between send-receive antennas are based on the antenna layout.
- Attach the antenna on the position specified in the drawing.
- Install the antenna not to make a feature change of the antenna considering the direction of the radiation
- Connect the antenna not making the alien substance flowed so that Passive Inter-Modulation Distortion (PMID) is not affected.
- Measure VSWR of all antennas and the value should be within the regulated value.

A.2 Sector Antenna Layout

The method of sector antenna layout is as follows.

- 1) Use the transit to adjust the antenna installation direction exactly.
- 2) Fix the direction of the sector antenna, same as the angle settled when designing the cell after installing the steel tower.
- 3) Arrange the antennas of each sector to the sector directional angle at right angles by adjusting the distance between antenna and steel tower.
In the event of the station whose the direction between sectors is not 120° , install it to make the steel tower and antenna direction different being careful of the tilt and azimuth.
- 4) For circular platform, separate the antenna interval at maximum.

A.3 Sector Antenna Installation

The method of sector antenna installation is as follows.

- 1) Put up an antenna pole and insert the sector antenna into the antenna pole using a fixing clamp.
- 2) Set the antenna's up/down tilt to 0° and fix the fixing clamps at the top and bottom.
- 3) After tightening the fixing clamp, adjust the antenna up/down (tilt) depending on the signal strength. The bolt of the guide clamp must be loosened, so the antenna angle can be adjusted.
- 4) After setting the antenna angle, tighten the bolt of the guide clamp, which was loosened previously. Regarding the nut, the double nut mounting should be used to prevent the nut from coming loose.

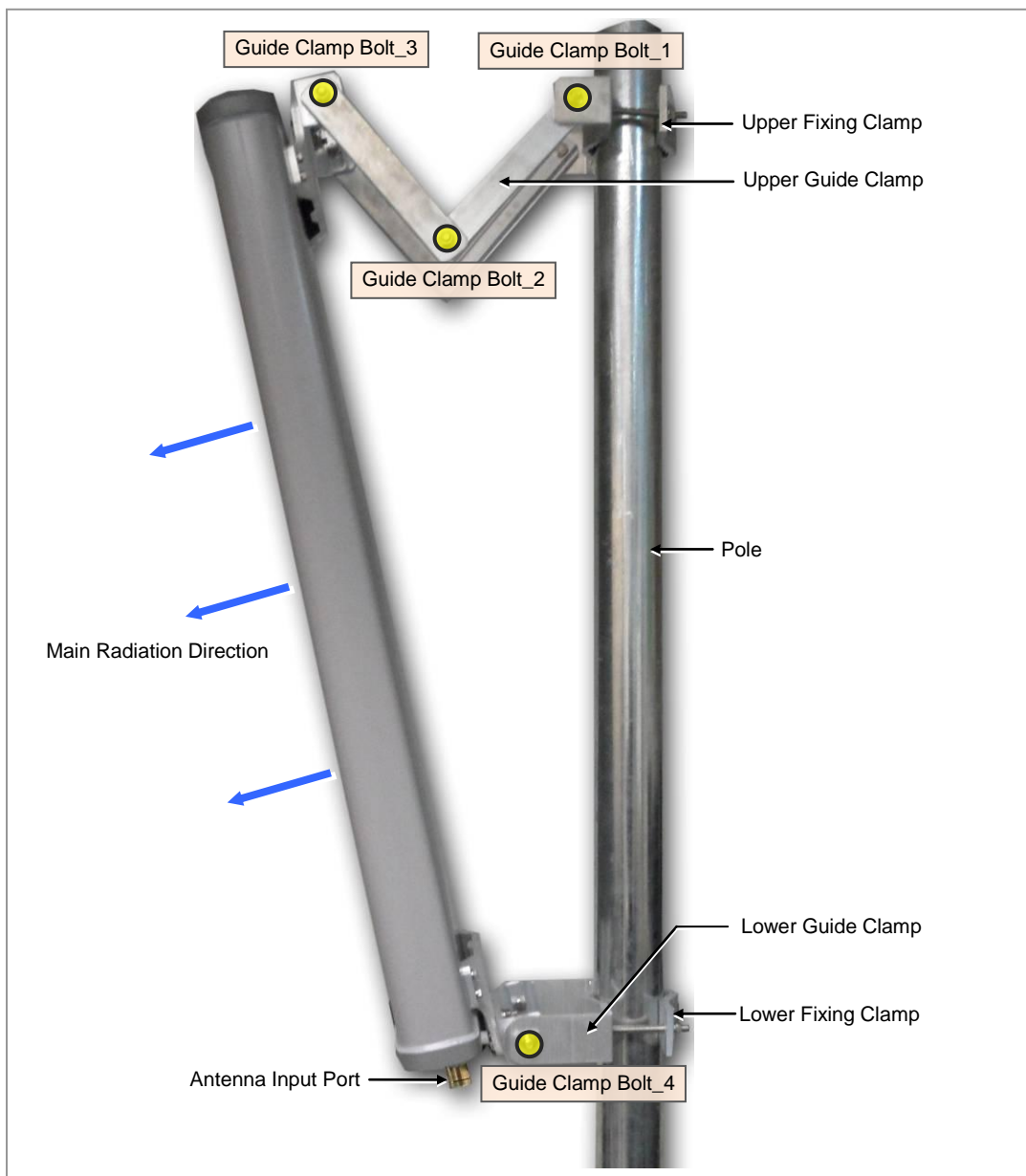
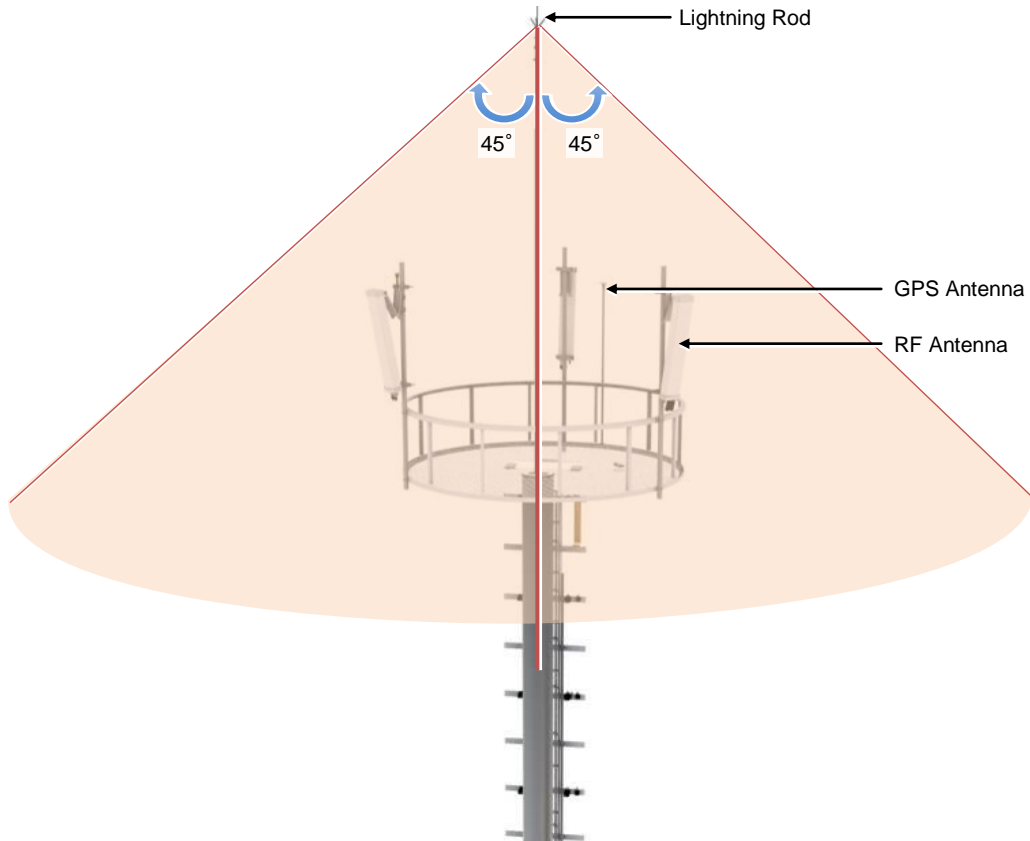

Figure A.1 Sector Antenna

**CAUTION****Installing the Antenna**

When you install the antenna, the antenna must be installed within the protective angle (left/right side 45° each from the central axis) of lightning rod to prevent the antenna from lightning damage.



ANNEX B. Installing Feeder Cable

B.1 Cautions When Installing Feeder Cable

When installing the feeder, the following cautions shall be considered:

- Put a plate to work not to make damage for the surface of the feeder cable.
If there is external damage of the feeder cable, cut the damaged part and work wiring.
- After connecting the antenna to the feeder cable, finish the connection part of the contracted pipe using the contracted tube.
- Attach the cognitive tapes to the both ends of the feeder cable, which makes it easy to recognize.
- When connecting cabinet, antenna and lightning arrestor, etc. to the feeder cable, connect strongly to prevent from generating reflected wave.
- The curvature radius should be maximized, keep the minimum curvature radius.

Table B.1 Curvature Radius of Feeder Cable for Outdoor

Specification		Allowed Radius of Curvature		Remark
LS Feeder Line	HFC-12D	1/2 in.	125 mm (4.92 in.)	Outdoor
	HFC-22D	7/8 in.	250 mm (9.84 in.)	
	HFC-33D	1-1/4 in.	380 mm (14.96 in.)	
	HFC-42D	1-5/8 in.	510 mm (20.08 in.)	
RFS Feeder Line	LCF12-50	1/2 in.	125 mm (4.92 in.)	
	LCF78-50	7/8 in.	250 mm (9.84 in.)	
	LCFS114-50	1-1/4 in.	380 mm (14.96 in.)	
	LCF158-50	1-5/8 in.	500 mm (19.69 in.)	



Table B.2 Curvature Radius of Feeder Cable for Indoor (Based on LS Feeder Line)

Specification			Allowed Radius of Curvature	Remark
LS Feeder Line	HFSC 6D	1/4 in.	25 mm (0.98 in.)	Indoor
	HFSC 10D	3/8 in.	25 mm (0.98 in.)	
	HFSC 12D	1/2 in.	32 mm (1.26 in.)	
	HFSC 22D	7/8 in.	125 mm (4.92 in.)	
RFS Feeder Line	SCF14-50	1/4 in.	25 mm (0.98 in.)	
	SCF38-50	3/8 in.	25 mm (0.98 in.)	
	SCF12-50	1/2 in.	32 mm (1.26 in.)	
	UCF78-50	7/8 in.	125 mm (4.92 in.)	

**Table B.3 Curvature Radius of LMR-400 (Based on Times Microwave System)**

Specification	Allowed Radius of Curvature	Remark
LMR-400	25.4 mm (1 in.)	Installation
	101.6 mm (4 in.)	Repeated

**Radius of Curvature of Feeder Line**

When installing a feeder line, the radius of curvature of the sections where cables bent should be larger than the allowed radius of curvature. If the radius of curvature for the feeder line installation is less than the allowed radius of curvature, it may affect the performance of the system.

- Ensure that the feeder cable does not interfere with steel towers, ladders and in the areas chiefly used by people.
- Connect the connector to the antenna in a straight line and after connecting, do not apply excessive force.
- Use the vinyl tape for electricity and heat shrink tube for the external exposed part of the connector not to avoid leak water.
- Wind the self-bonding rubber tape overlapping (keep a distance as the half size of rubber tape) to the connector connection part and wind the vinyl tape for electricity to the 2 times or more and then cover with the jelly type heat shrink tube.



Connection of Feeder Cable Connector

Connecting the feeder cable connector is critical process, so the qualified workers who finished the related education should perform.

Table B.4 Connector Connection Torque Value

Connector	Torque Value
SMA connector	2.5 kgf·cm (0.18 lbf·ft)
TNC connector	9 kgf·cm (0.65 lbf·ft)
N-type connector	20 kgf·cm (1.45 lbf·ft)
Din-type connector	200 kgf·cm (14.46 lbf·ft)

B.2 Antenna Feeder Cable Ground

Ground the antenna feeder line using the grounding kit located under the Tower Ground Bar (TGB) installed in the lower section of the tower or in the antenna feeder line duct.

The procedure for connecting the ground kit to the feeder line is as follows:

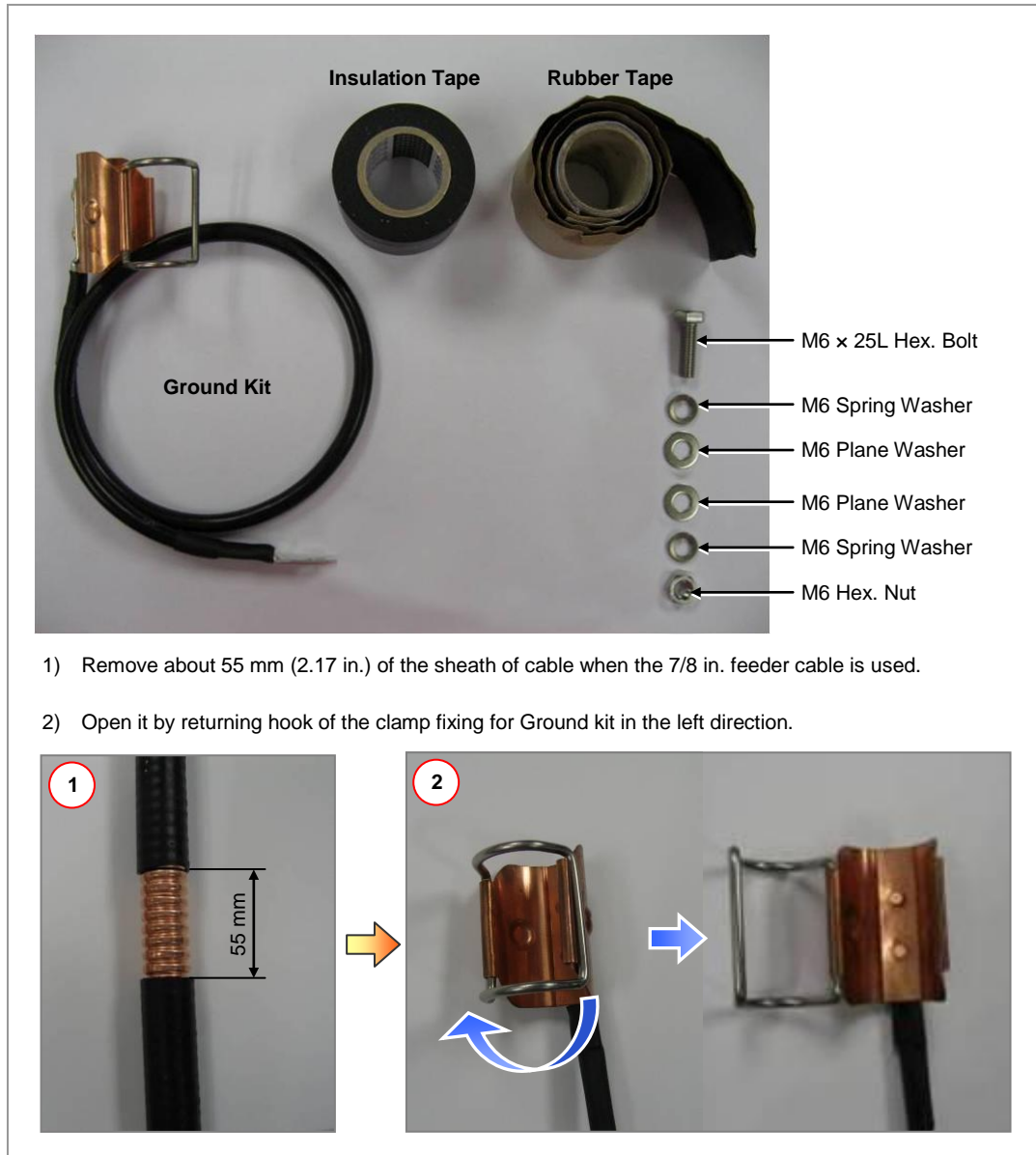

Figure B.1 Feeder Cable Grounding (1)

- 3) Insert the ground kit clamp into the place from which the feeder line sheath is removed.
- 4) Pull the clamp lock to the upward so that the lock can be hung on the global protrusion area on the side.
- 5) Overlap the exposed part of the ground kit clamp using rubber tape (Keep a distance as the half size of rubber tape) and press it with your hands lightly to make rubber tape adhere well.
- 6) Wrap the part where the rubber tape is attached using insulation tape two times or more. When cutting off the tape, cut it off neatly using a cutting device such as scissors or a knife.

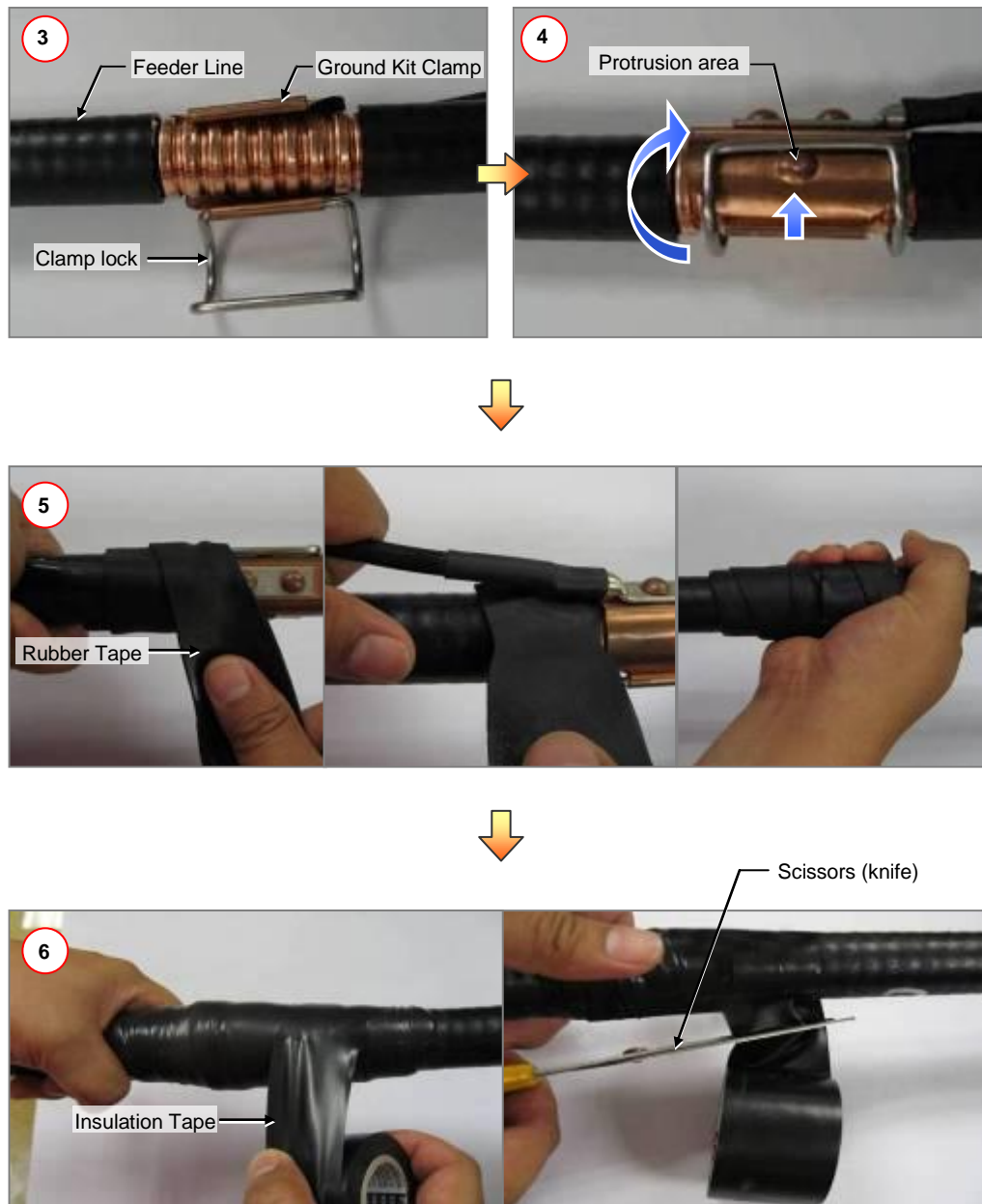

Figure B.2 Feeder Cable Grounding (2)

- 7) Align the 42 mm (1.65 in.) heat shrink tube [jelly type, 200 mm (7.87 in.)] inserted when installing the feeder line into the fixing part of the ground kit.
- 8) Shrink the heat shrink tube [jelly type, 200 mm (7.87 in.)] by heating gun.

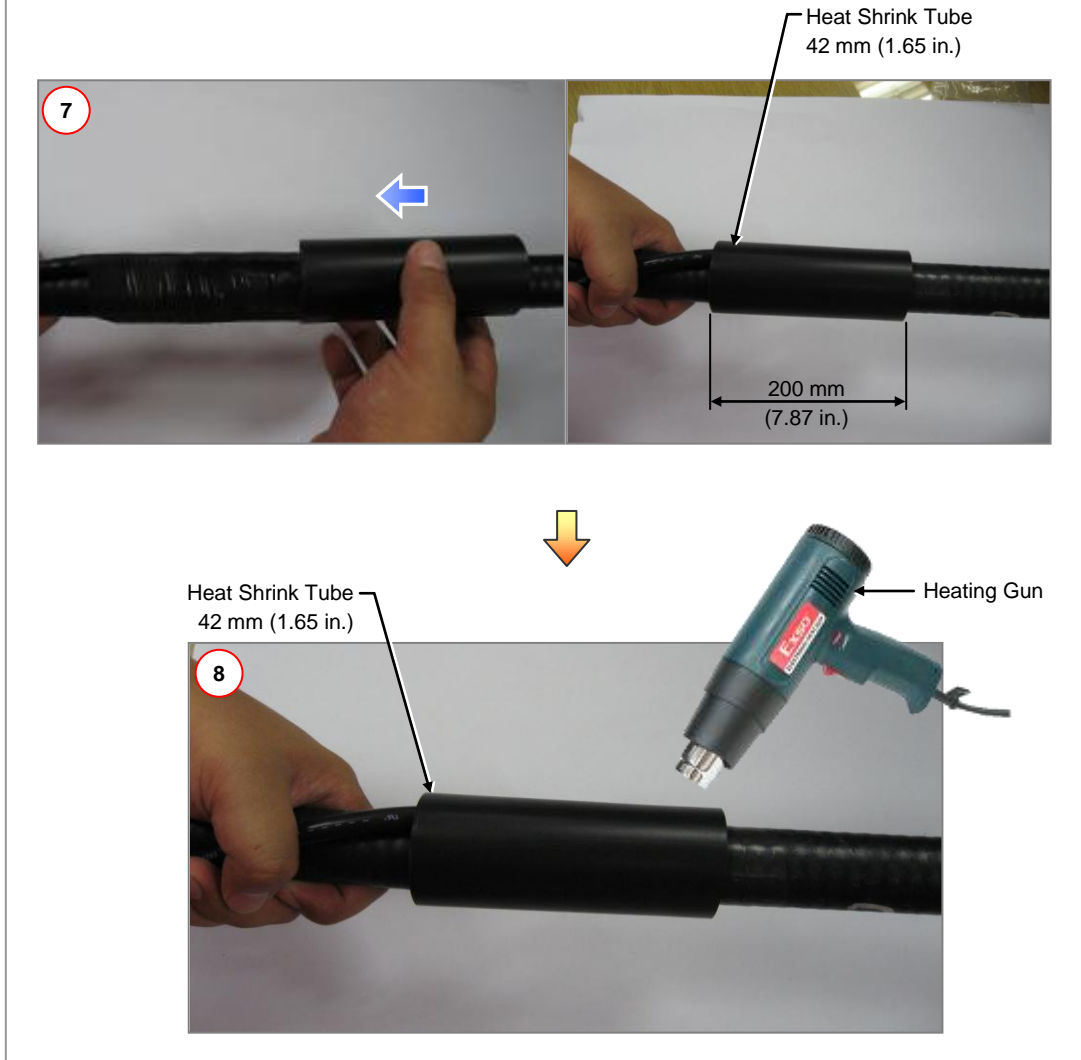

Figure B.3 Feeder Cable Grounding (3)

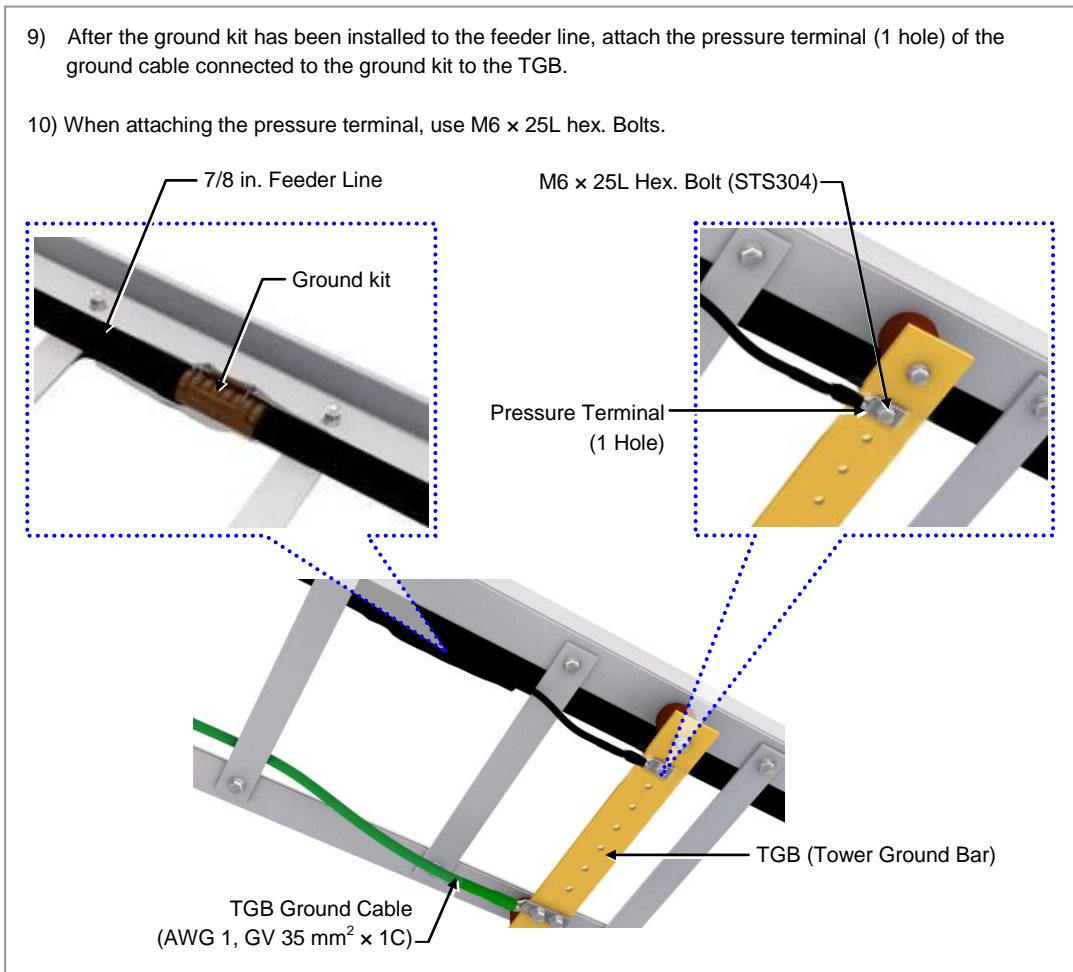

Figure B.4 Feeder Cable Grounding (4)



Checking the Ground Kit and TGB Specifications

The specifications, clamp, and pressure terminal type of the ground kit and TGB differ depending on manufacturers. Make sure to check the specifications of the ground kit and TGB, and identify the installation method before installing it.

Table B.5 TGB Installation Example

Category	Description
TGB Usage	Earth terminal board for feeder cable for grounding in using the feeder cable of more than 7/8 in.
TGB Location	Lower section of cable rack in feeder cable duck - Less than 20 m (65.62 ft): 1 (Ex. steel tower lower section) - Exceed 20 m (65.62 ft): 2 or more (Ex. steel tower lower and upper section)
Material	Pure copper
Installation Method	Using the insulator to separate from the steel tower electrically
Connection Method	Extract the AWG1, GV 35 mm ² ground cable to the direction of the floor and weld it to the tower's ground cable.

B.3 Tower Ground Construction

- 1) Install a Tower Ground Bar (TGB) that will be used to ground a feeder cable onto the tower. If the height of the tower is exceeds 20 m (65.62 ft), two or more TGBs should be installed (onto the lower and upper sections of the tower). If the tower is 20 m (65.62 ft) or less, one TGB should be installed. Since the TGB installation location and the number of TGBs to be installed can differ depending on the system environment and provider's standards, consult your service provider.
- 2) Each TGB should be grounded and separated from other grounds. If there is an existing ground bar or ground cable for TGB, install the TGB by branching from it using a ground cable (AWG 1, GV 35 mm² × 1C) ground cable. (However, the specification of TGB ground cable can be different, depending on the standard of service provider.)
- 3) Tighten the ground kit (feeder cable grounding assembly) to the TGB ground terminal and the tower hole using the pressure terminal hole attached at the end of the ground kit's ground cable.

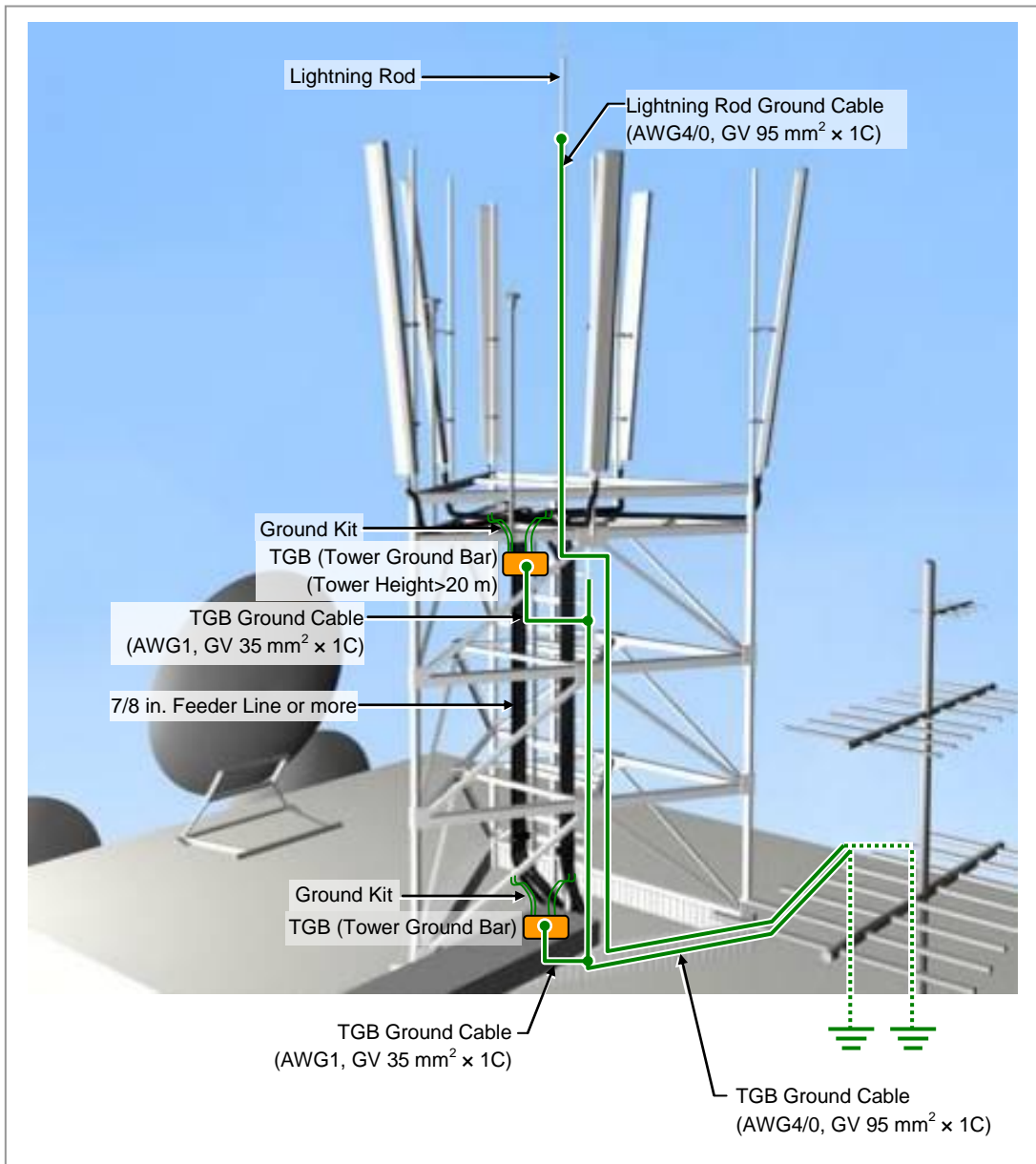

Figure B.5 Connecting the Tower Ground Cable

ANNEX C. Connector Assembly

C.1 N type-male (1/2 in. feeder line)

Below is the method for assembling the N type-male connector to the 1/2 in. feeder line.

- 1) The components of the N type-male are an N type-male body, an insert ring, a clamping nut, O-ring, and a heat shrink tube, and it is assembled using the wire stripper, trimming tool, spanner, etc.

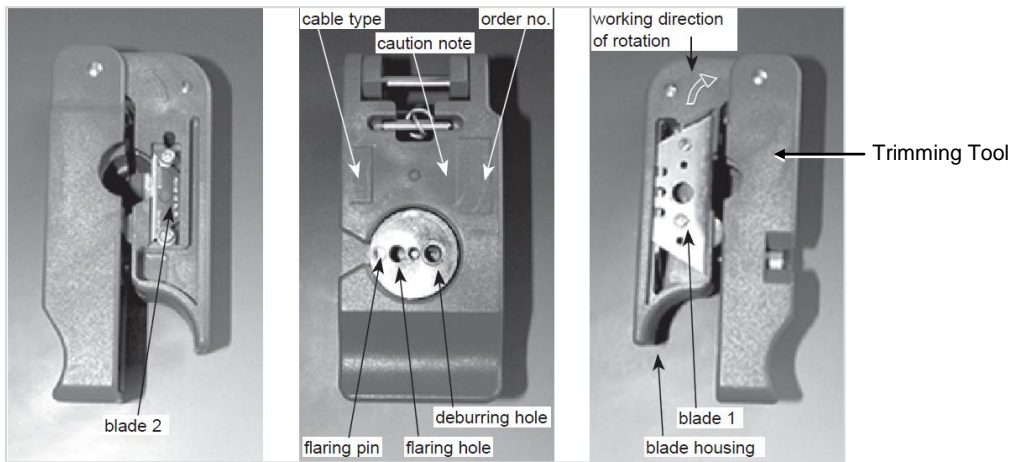
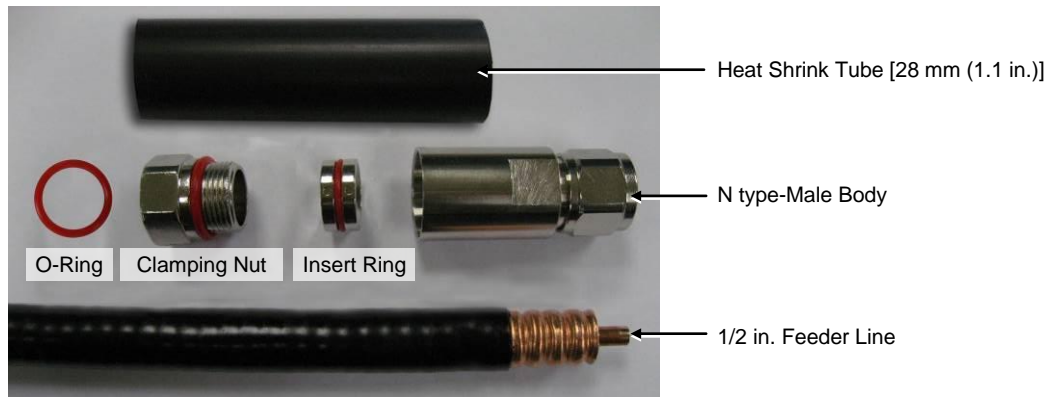

- 2) Using a stripping tool or a knife, strip the 1/2 in. feeder line by 25 mm (0.98 in.) from the end, as shown in the figure below.

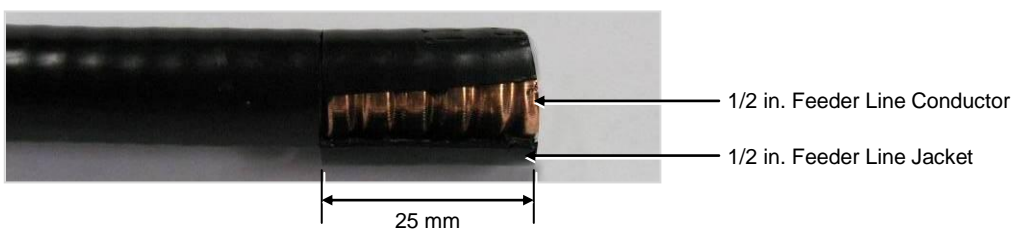
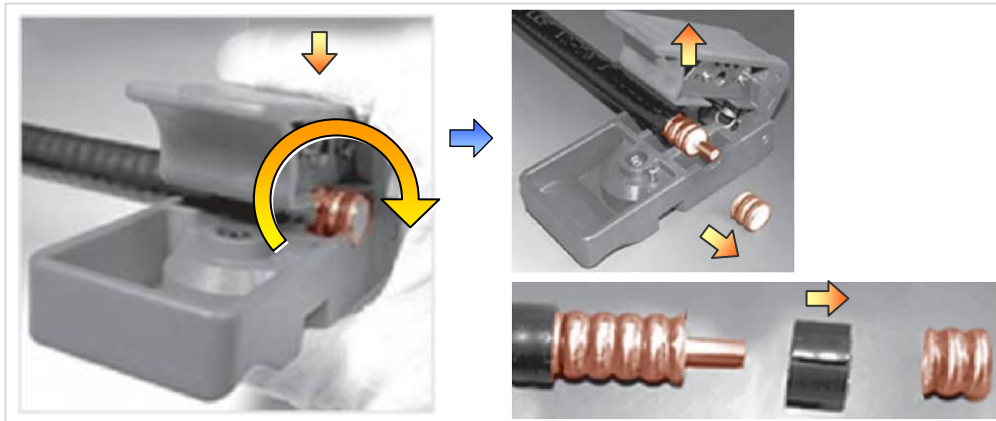
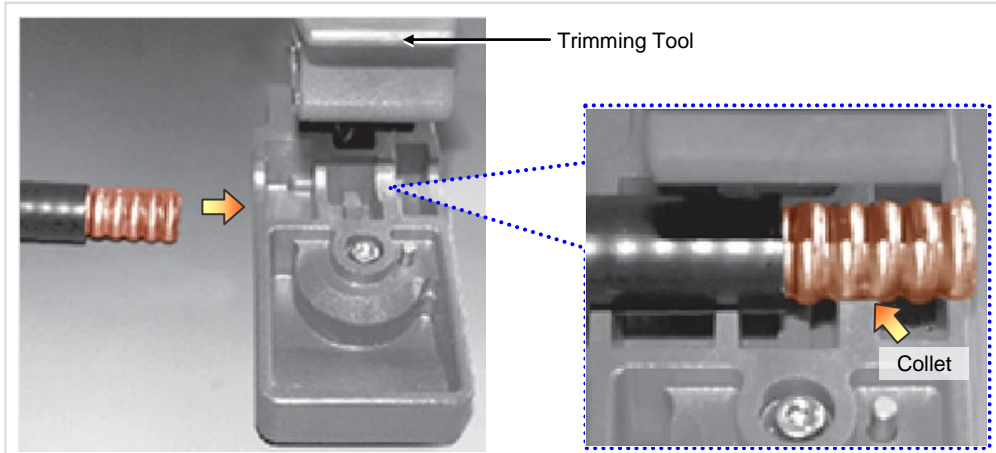

Figure C.1 Assembling the N type-male (1/2 in. Feeder Line) Connector (1)

- 3) Remove the 11 mm (0.43 in.) of the external conductor end and 10 mm (0.39 in.) of the jacket using a trimming tool.



- 4) Insert the internal conductor into the deburring hole at the bottom of the trimming tool to trim it.

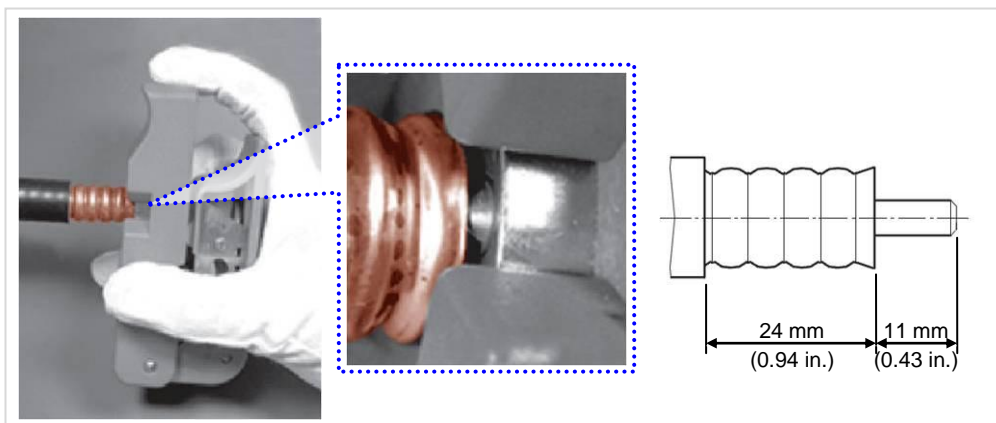

Figure C.2 Assembling the N type-male (1/2 in. Feeder Line) Connector (2)

- 5) Insert the o-ring, clamping nut, insert ring and N type-male body to the stripped 1/2 in. feeder line in this order. O-ring is inserted into the second groove from inside of outer insulator.
- 6) Tighten the clamping nut and N type-male body inserted into the 1/2 in. feeder line firmly using a spanner. The recommended torque for tightening the clamping nut and N type-male body is 30~50 N.m (306~510 lbf·ft). (Note that it should only be tightened by rotating the external body with the clamping nut in a fixed and stable position.)

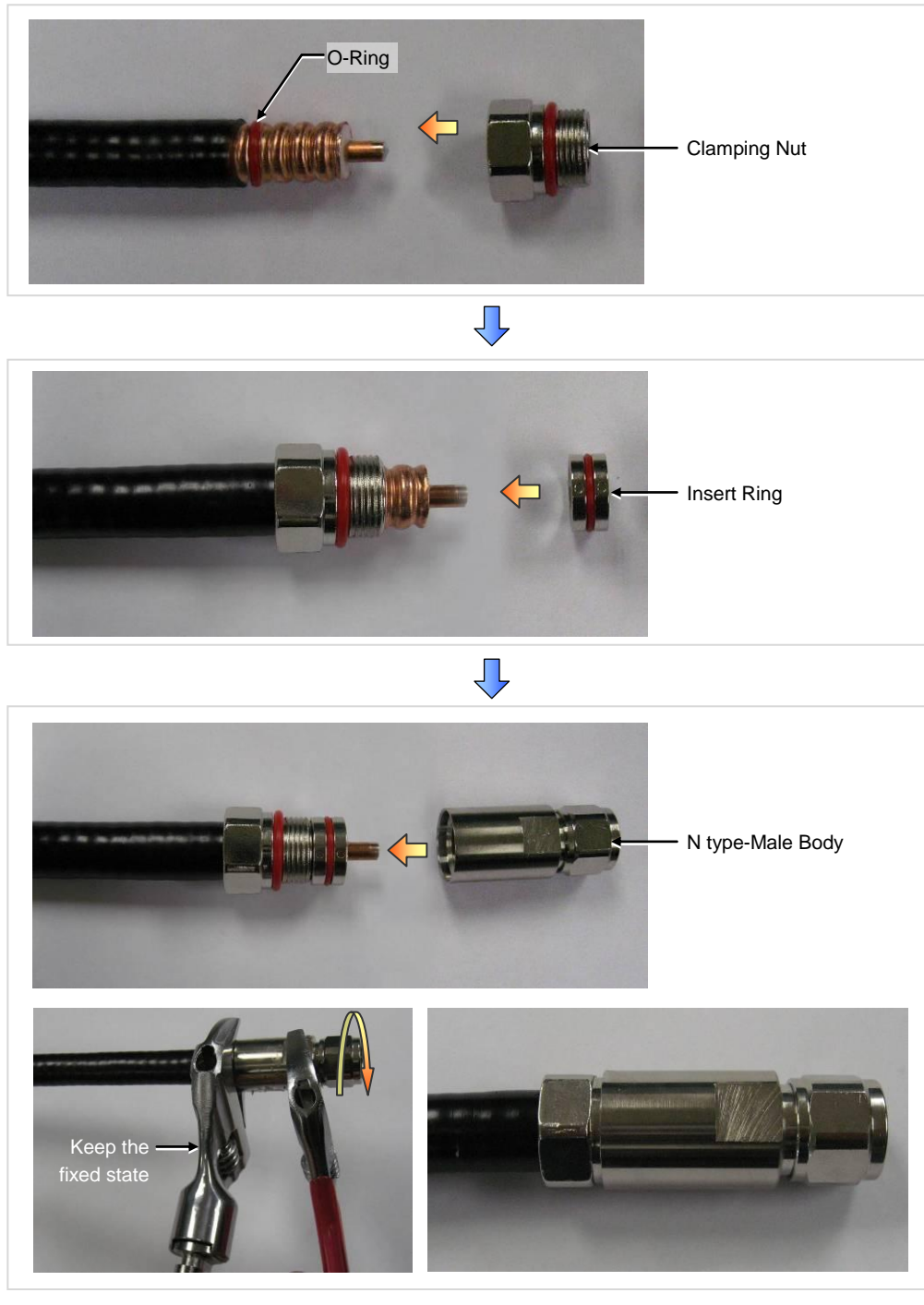

Figure C.3 Assembling the N type-male (1/2 in. Feeder Line) Connector (3)

- 7) Insert the heat shrink tube into the 1/2 in. feeder line fitted with the N type-male connector as shown in the figure below.
 - Heat shrink tube: Φ 28 mm, 100 mm (Φ 1.1 in., 3.94 in.)
- 8) Shrink the heat shrink tube inserted into the 1/2 in. feeder line using a heating gun.

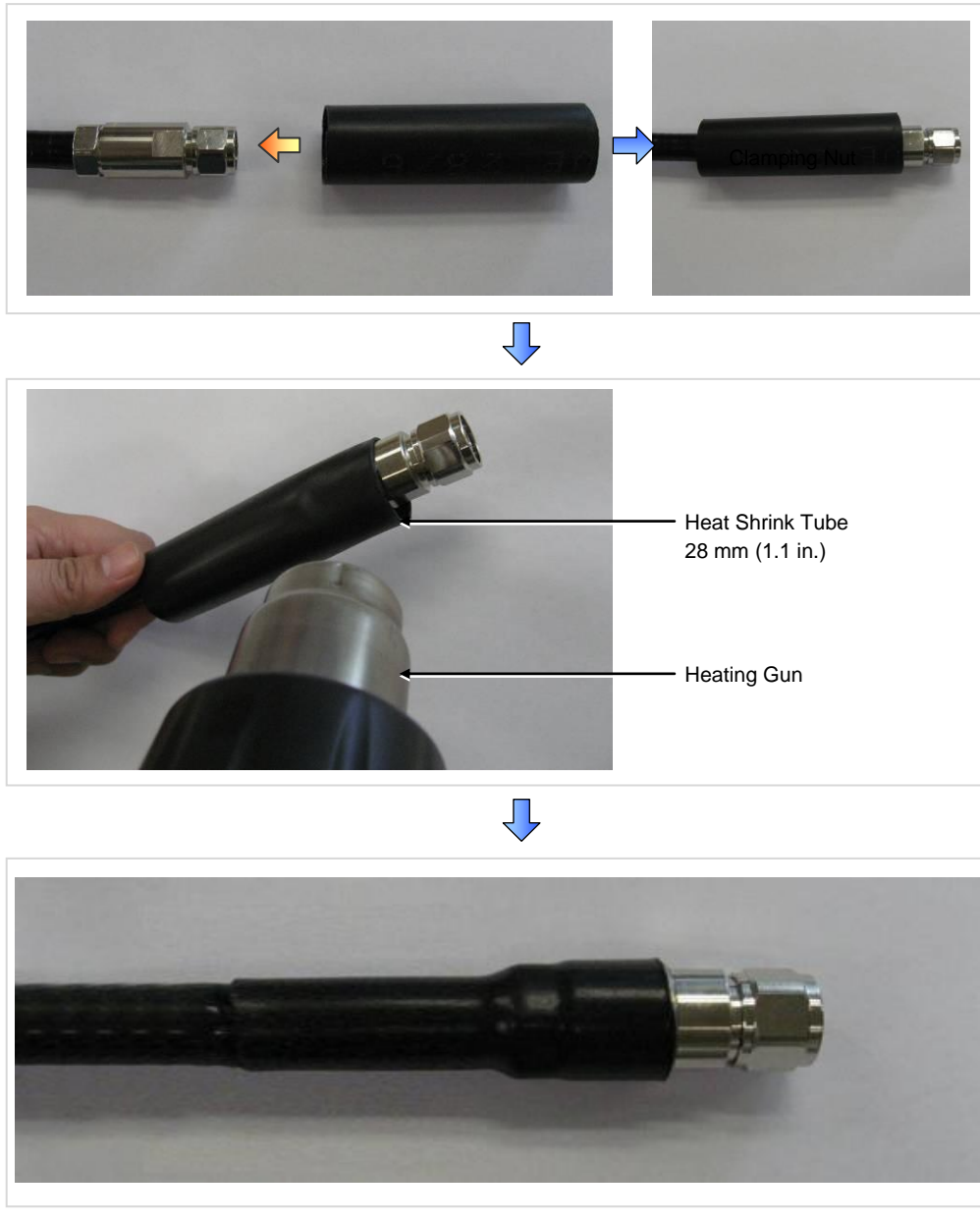

Figure C.4 Assembling the N type-male (1/2 in. Feeder Line) Connector (4)



CHECK

Checking to carry out when assembling the N type-male connector

The shape, tool and assembly method may differ depending on the connector type and manufacturer. Make sure to check the user manual provided by the manufacturer before assembling.

C.2 Din type-male (1/2 in. Feeder Line)

Below is the method for assembling the Din type-male connector to the 1/2 in. feeder line.

- 1) The components of the Din type-male are an Din type-male body, pin, an insert ring, a clamping nut, o-ring, and a heat shrink tube, and it is assembled using the wire stripper, trimming tool, wrench, etc.

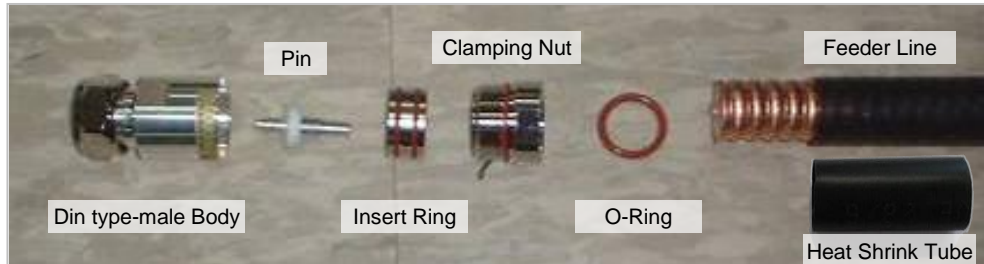

- 2) Straighten the cable, then, using a suitable tool, strip it to the connector's wire strip length. When cutting the sheath, hold the cable firmly with one hand and cut the cable pulling the cutting tool inwards with the other hand. Gently rotate the tool several times (do not pull it too hard), so that the internal copper line is not damaged.



- 3) Using a cutter, cut the sheath from the stripped edge to the end of the cable and completely strip the sheath.

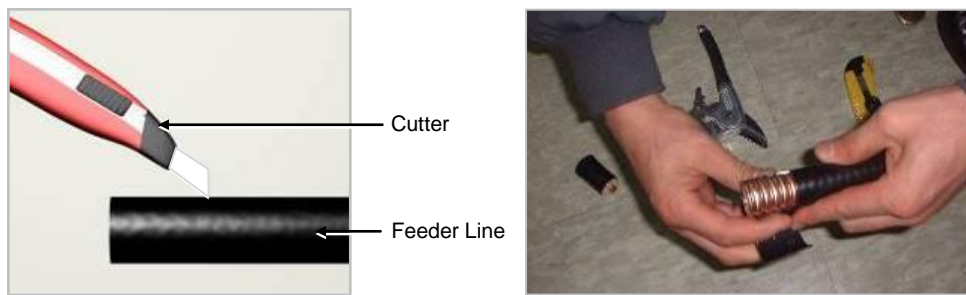

- 4) Insert the o-ring, clamping nut, insert ring, pin and Din type-male body into the stripped feeder line in this order.



Figure C.5 Assembling the Din type-male (1/2 in. Feeder Line) Connector (1)

- 5) Tighten firmly the clamping nut and Din type-male body inserted to the 1/2 in. feeder line using a wrench. The recommended torque for tightening the clamping nut and Din type-male body is 30~50 N.m (306~510 lbf·ft) (Note that it should only be tightened by rotating the external body with the clamping nut in a fixed and stable position.)

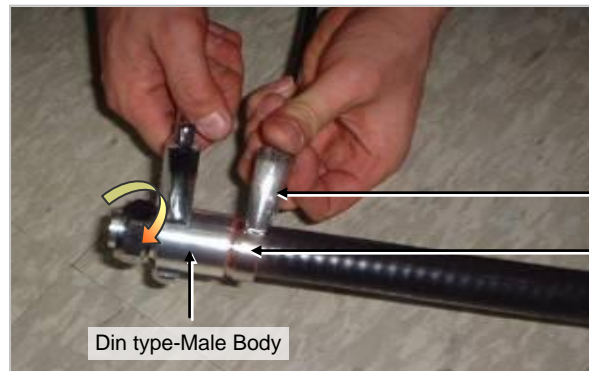

Spanner (keep the fixed state)

Clamping Nut

Din type-Male Body

- 6) Insert the heat shrink tube [28 mm/10 cm (1.10 in./3.94 in.)] to the 1/2 in. feeder line fitted with the Din type-male connector; and shrink the heat shrink tube inserted into the feeder line using a heating gun.



Heating Gun

Heat Shrink Tube



Figure C.6 Assembling the Din type-male (1/2 in. Feeder Line) Connector (2)



CHECK

Checking to carry out when assembling the Din type-male connector

The shape, tool and assembly method may differ depending on the connector type and manufacturer. Make sure to check the user manual provided by the manufacturer before assembling.

C.3 Finishing the Connector Connection Part by Tape

Finishing the connector connection part by tape (insulation tape, rubber tape, etc.) in the outdoor environment is as follows:

- 1) Overlap the exposed part of the connector connection part using rubber tape (Keep a distance as the half size of rubber tape) and press it with your hands lightly to make rubber tape adhere well.
- 2) Wrap the part where the rubber tape is attached using insulation tape two times or more. When cutting off the tape, cut it off neatly using a cutting device such as scissors or a knife.
- 3) Bind the end part of the insulation tape using cable tie to prevent slips.

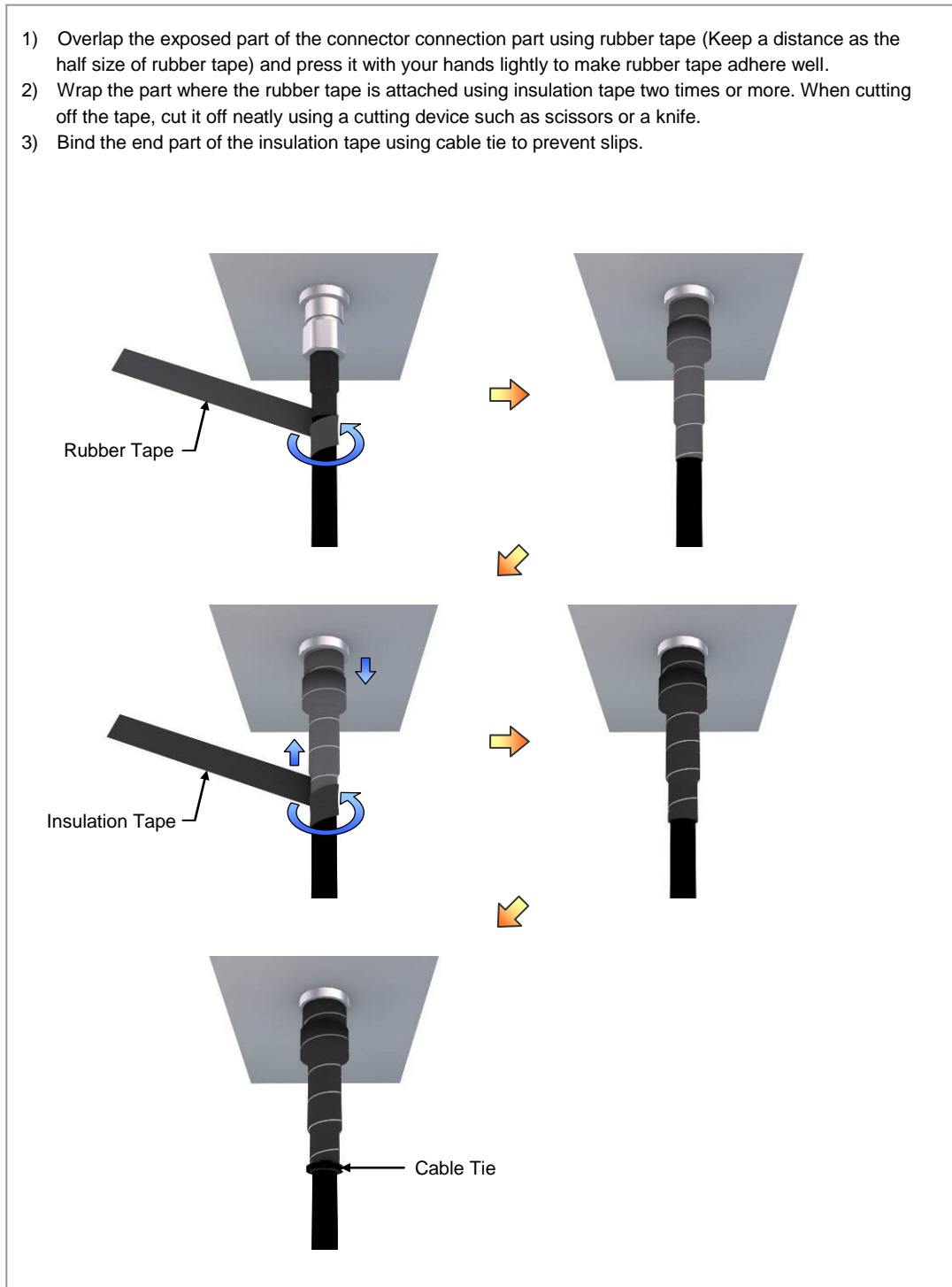

Figure C.7 Finishing the Connector Connection Part by Tape

C.4 How to Shrink the Heat Shrink Tube

C.4.1 When Assembling a Connector to the Feeder Line

Below is the procedure for shrinking the heat shrink tube.

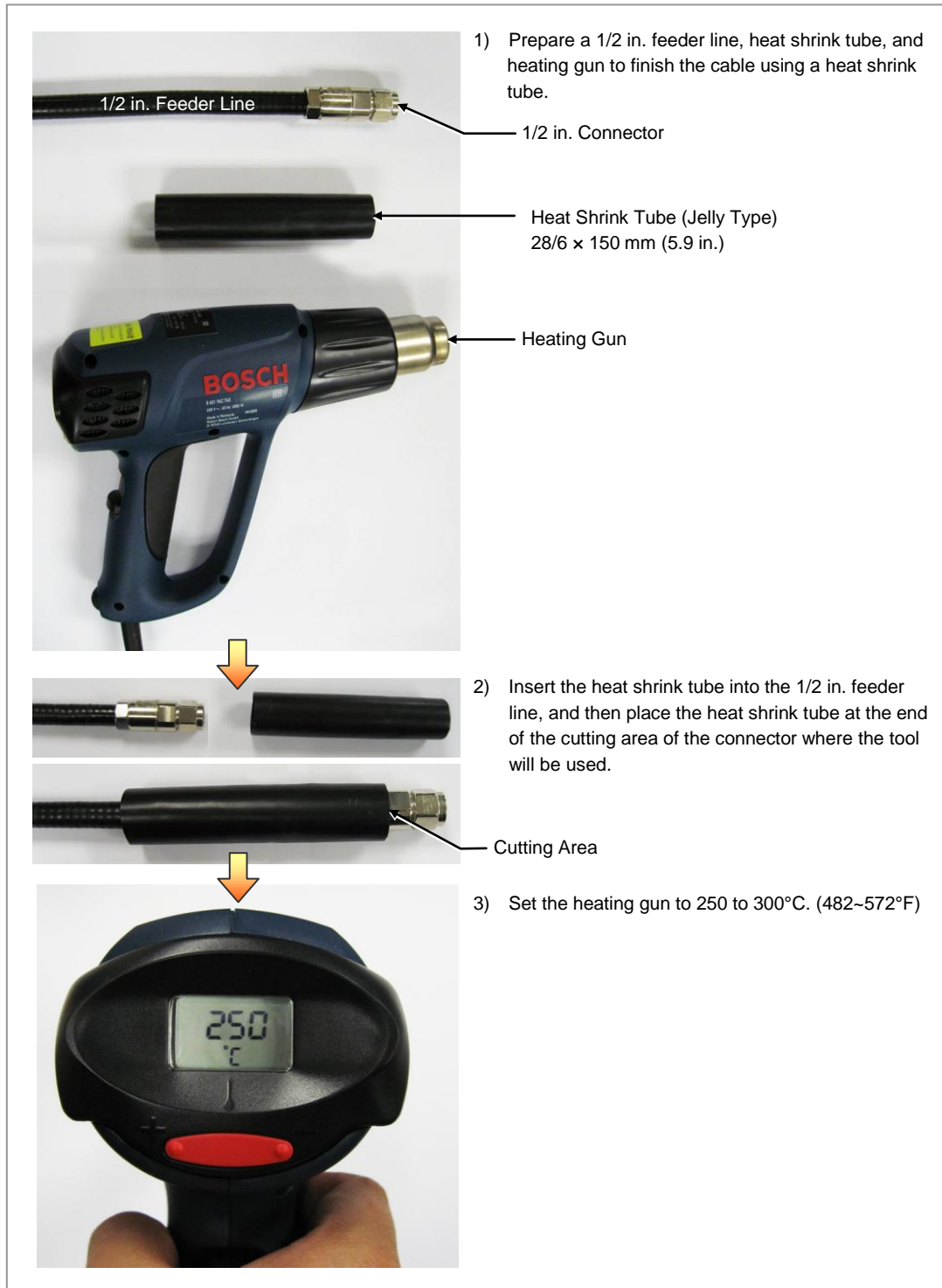

Figure C.8 Shrinking the Heat Shrink Tube_Feeder Line (1)



Figure C.9 Shrinking the Heat Shrink Tube_Feeder Line (2)

C.4.2 When Connecting a Connector to another Connector

Below is the procedure for shrinking the heat shrink tube.



Figure C.10 Shrinking the Heat Shrink Tube_Connection between Connectors (1)

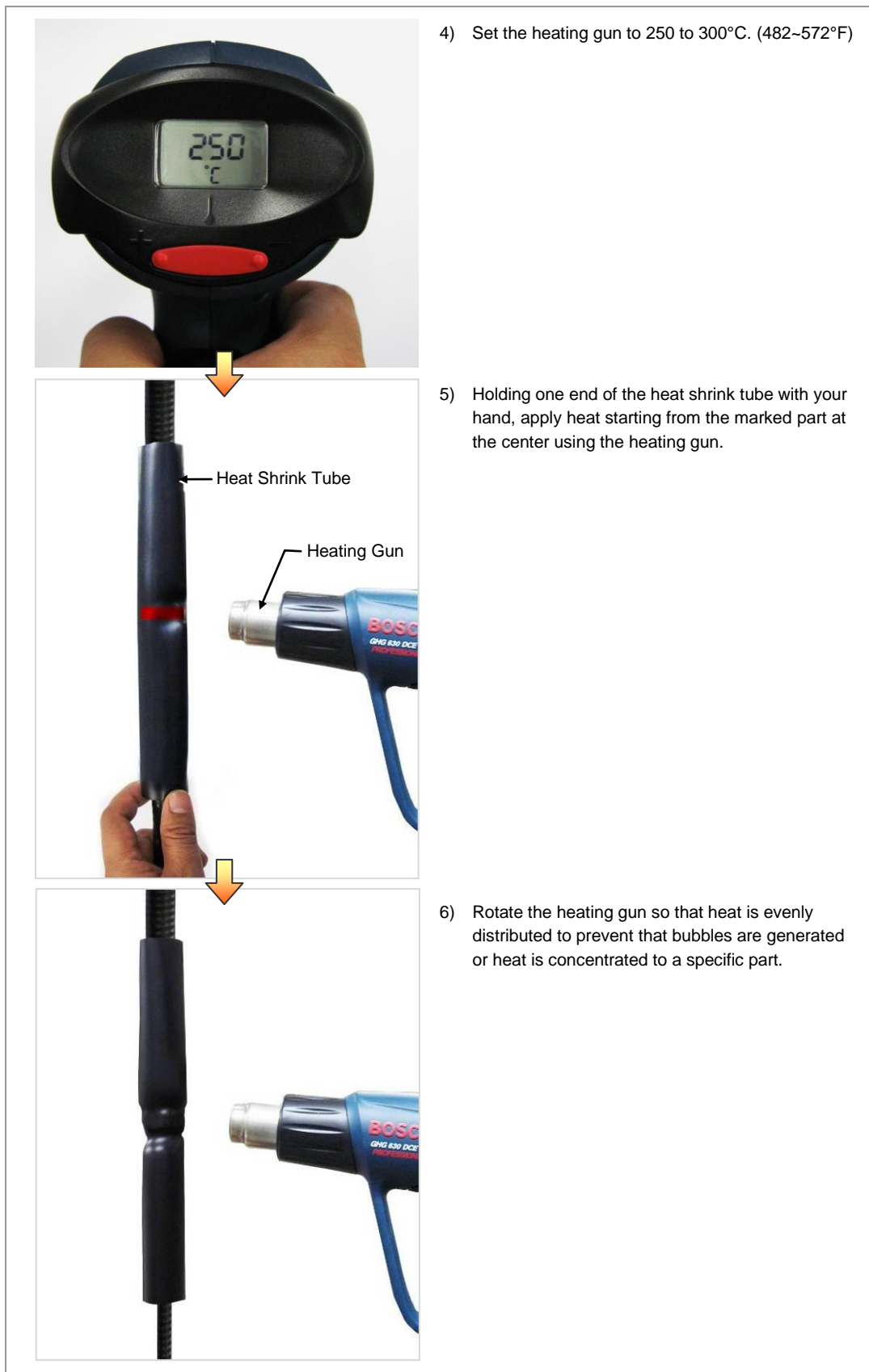

Figure C.11 Shrinking the Heat Shrink Tube_Connection between Connectors (2)

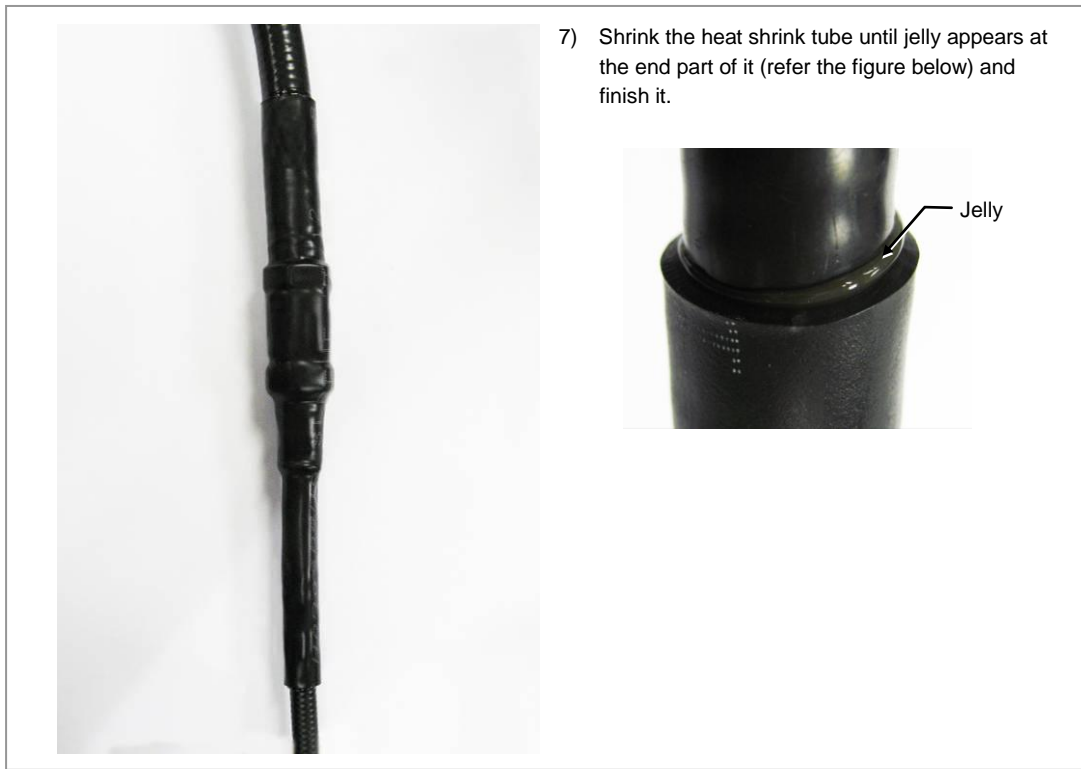

Figure C.12 Shrinking the Heat Shrink Tube_Connection between Connectors (3)

**CHECK****Check for Working with the Heat Shrink Tube**

- If you work without holding one end of the heat shrink tube, the location of the heat shrink tube may be changed. Therefore, make sure to hold one end of it when applying heat.



- The connector part where 1/2 in. and 7/8 in. feeder line are connected must be the center of the heat shrink tube. After inserting the heat shrink tube, mark the center part.



- If jelly does not appear on the end of the heat shrink tube, it may mean that it is not shrunk properly. Apply heat until jelly appears using a heating gun.



C.5 Power Connector Assembly

The procedure for assembling the power connector (Amphenol, CJE-AL06M25U15-2S) is as follows.

- 1) Cut the power cable to the length of installing section.
- 2) Strip the external sheath of the cable for the connector about 35 mm (1.38 in.) from the end and sheath of internal core conductor about 10 mm (0.39 in.).

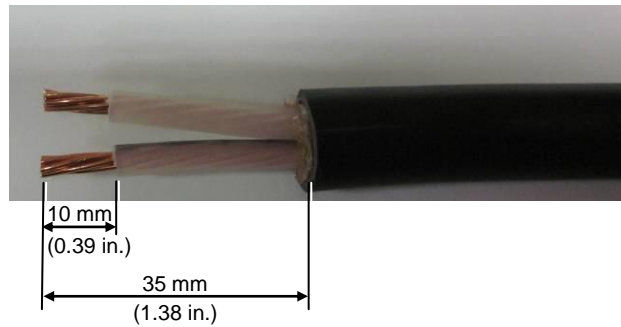

- 3) Solder the connector pin after inserting it into the stripped core conductor. After soldering, check if the connector pin is firmly fixed.



- 4) Insert the connector parts into the cable with the connector pin as below.



Figure C.13 Power Connector Assembly (1)

- 5) Insert the connector pin assembled with the power cable into the end of connector. The pin map of connector end and cable is as below.

- C: -48 VDC/Black
- D: Return/White

Push the pin into the end and check if it does not pull off.



- 6) After connecting the connector end and the pin assembled with the cable, assemble the connector parts to the connector end one by one.



- 7) Place the heat shrink tube [38 mm (1.50 in.)] to the lead-in part of connector cable, and shrink it using the heating gun. Do not shrink the tube for too long time since the jelly might come out too much.

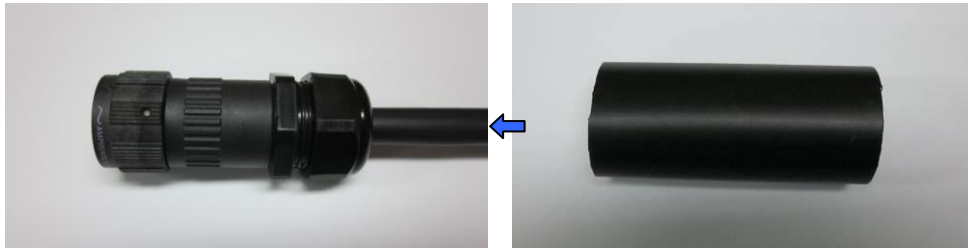

Figure C.14 Power Connector Assembly (2)

ANNEX D. Cleaning Optic Connector

D.1 Cleaning Optic Connector

When connecting optical cable to the system, performance of system can be decreased or fails can occur if core section of optical connector is dirty due to dust or foreign material. Therefore, worker should clean the optic connector before connecting optic cable to the system to prevent this phenomenon.

This manual describes the method that cleans optic connector when using the IBC™ Brand cleaner.



Caution When Connecting the Optical Cable

When connecting the optical cable, be careful to keep the cutting section of the connector core away from dust or foreign material.

If the cable is soiled with foreign material, do not blow to remove them. Make sure to clean the connector in accordance with the cleaning directions below.



When using Optic Connector Cleaner

When using optic connector cleaner, use the products shown in the example below or their equivalents.

- Ex) Manufacturer-USCONEC (<http://www.usconec.com>)
- IBC™ Brand Cleaner (P/N: 9393): For LC-LC and MU Connector Cleaning
 - IBC™ Brand Cleaner (P/N: 9392): For SC Connector Cleaning
 - IBC™ Brand Cleaner (P/N: 12910): For ODC Connector Cleaning



Manufacturer-TheFibers (www.thefibers.com)

- HuxCleaner 1.25 mm (0.05 in.) Type: For LC and MU Connector Cleaning
- HuxCleaner 2.5 mm (0.10 in.) Type: For SC, FC and ST Connector Cleaning



D.2 IBC™ Brand Cleaner

Method that uses IBC™ Brand Cleaner is as follows:

D.2.1 IBC™ Brand Type Cleaner (P/N 9393)

Method that uses IBC™ Brand Cleaner for LC-LC and MU connector is as follows:

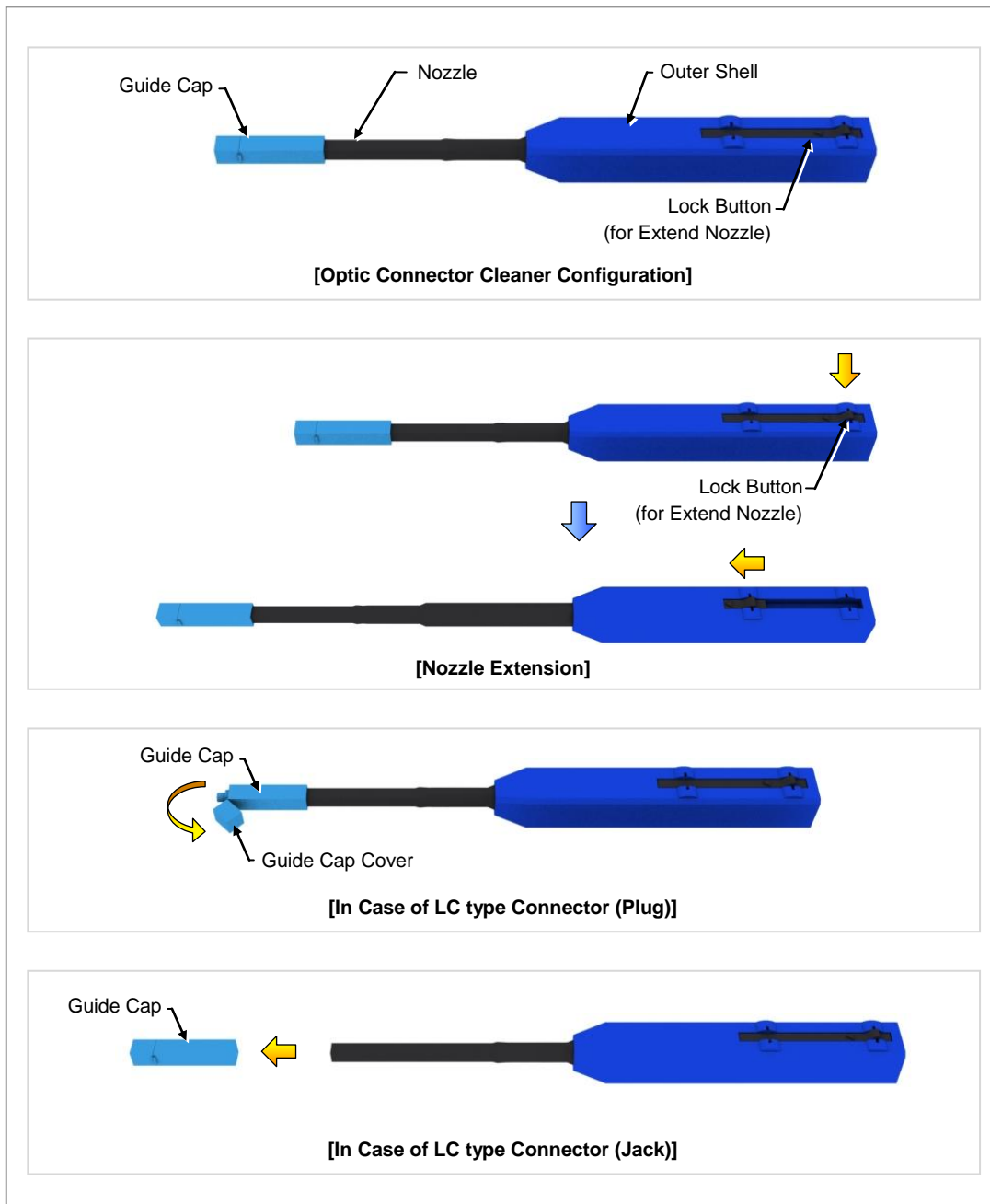
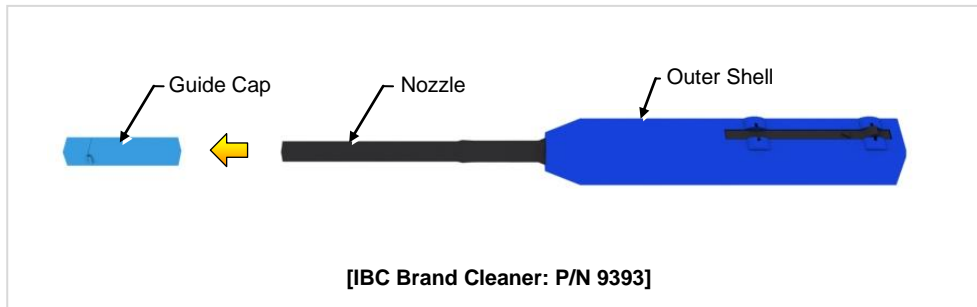

Figure D.1 Optic Connector Cleaner (IBC™ Brand Type Cleaner: P/N 9393)

Optic Module Cleaning (LC Type Jack)

- 1) To clean the optic module, remove the guide cap from the cleaner (P/N: 9393).



- 2) Insert a cleaner guide cap to every core of the optic module. Clean it by pushing the outer shell toward the nozzle until you hear the sound of the detergent being sprayed. (Repeat once or twice.)

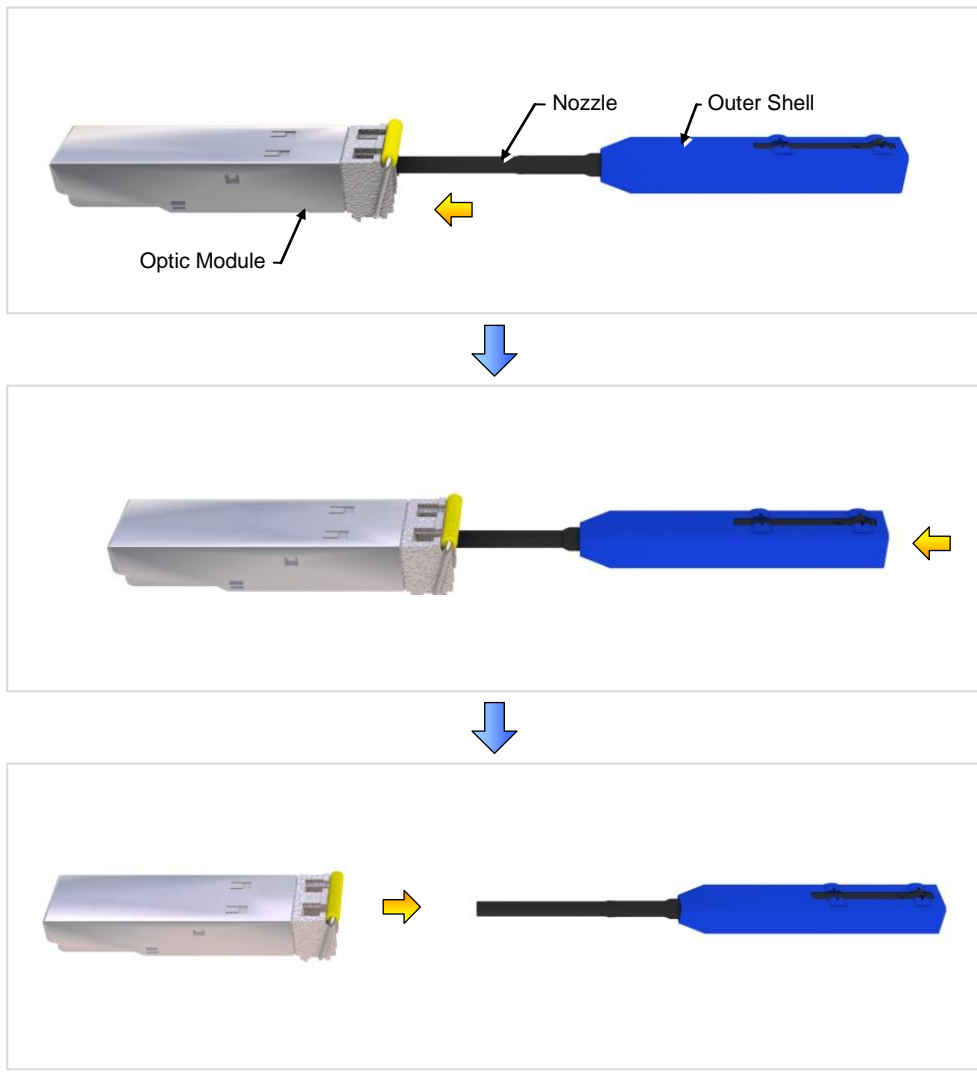
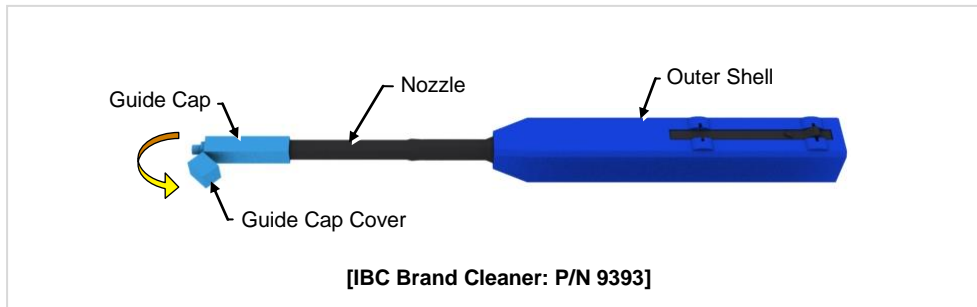

Figure D.2 Optic Module Cleaning (LC Type Jack)

Optic Cable Connector Cleaning (LC Type Plug)

- 1) To clean the optic cable connector, open the guide cap cover from the cleaner (P/N: 9393).



- 2) Insert a cleaner guide cap to every core of the optic cable connector. Clean it by pushing the outer shell toward the nozzle until you hear the sound of the detergent being sprayed. (Repeat once or twice.)

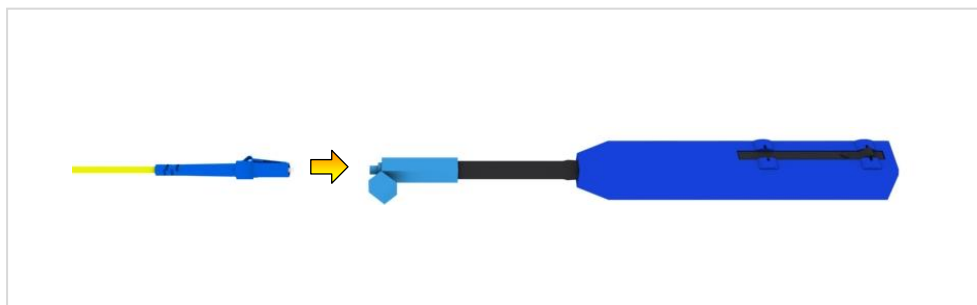
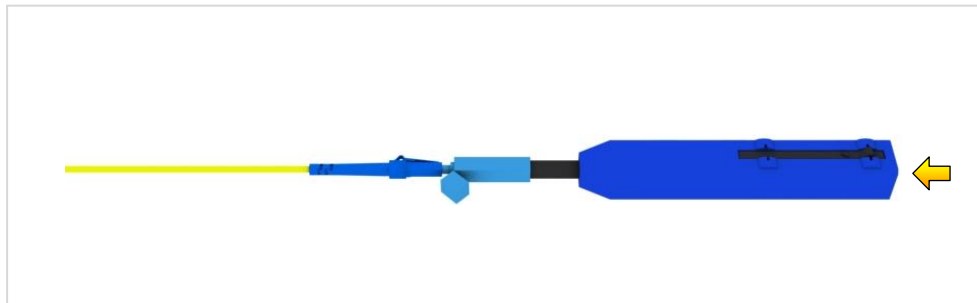
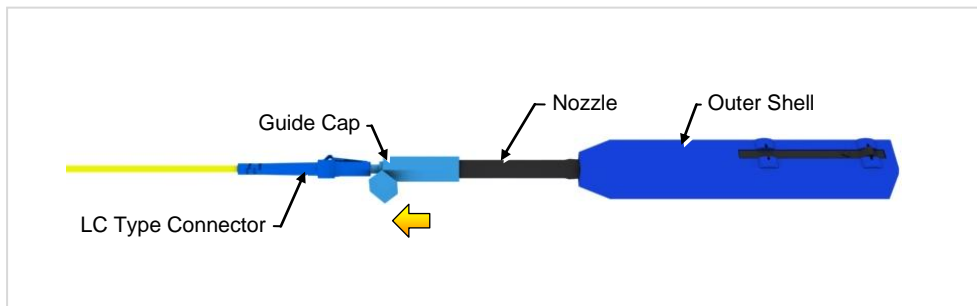

Figure D.3 Optic Cable Connector Cleaning (LC Type Plug)

D.2.2 IBC™ Brand Type Cleaner (P/N 12910)

Method that uses IBC™ Brand Cleaner for ODC connector is as follows:

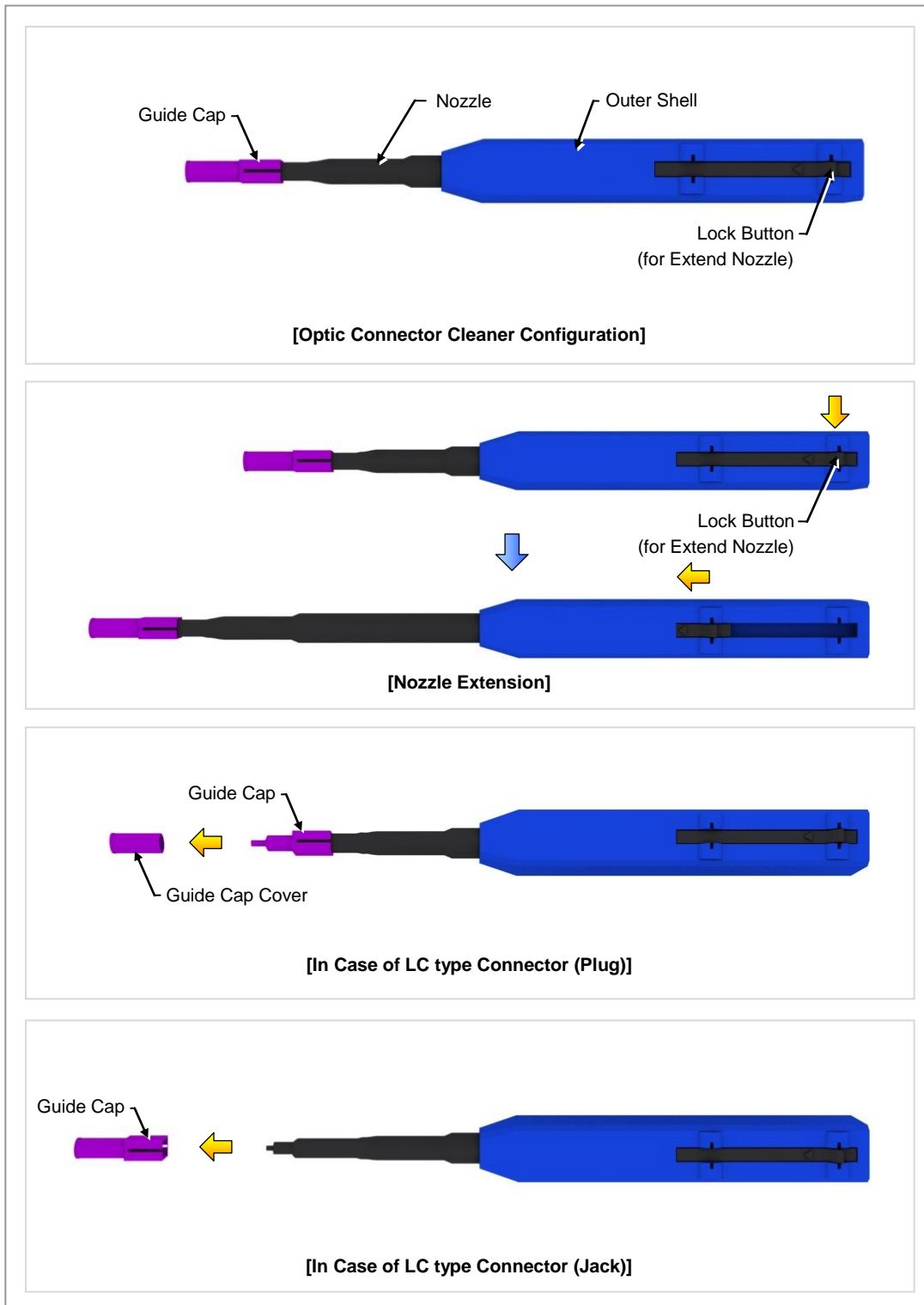
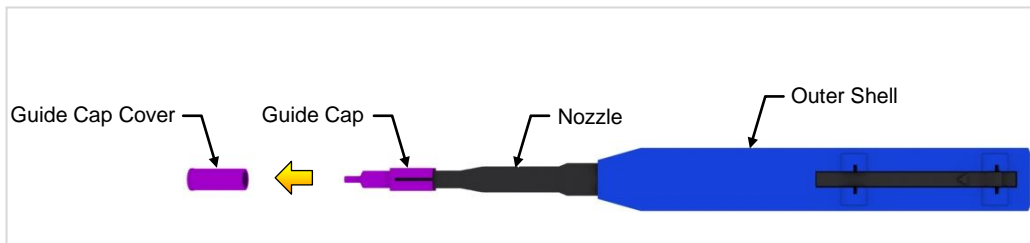

Figure D.4 Optic Connector Cleaner (IBC™ Brand Type Cleaner: P/N 12910)

Optic Port Cleaning (ODC, PT/LC Jack)

- 1) To clean the optic port of system, remove the guide cap from the cleaner.



- 2) Insert a cleaner guide cap to every core hole of the system's optic port. Clean it by pushing the outer shell toward the nozzle until you hear the sound of the detergent being sprayed. (Repeat once or twice.)

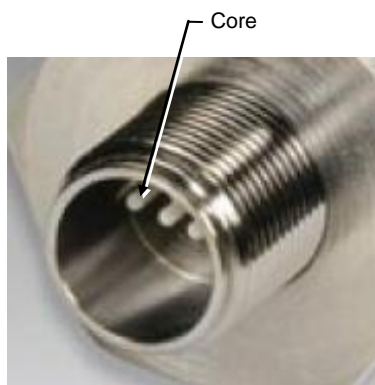

[Optic Port of System: ODC-4]

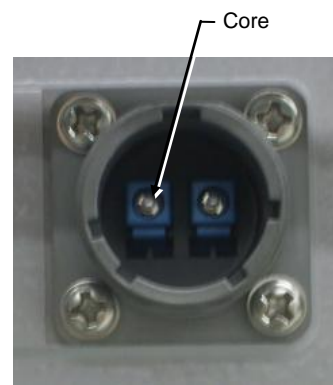

[Optic Port of System: PT/LC]

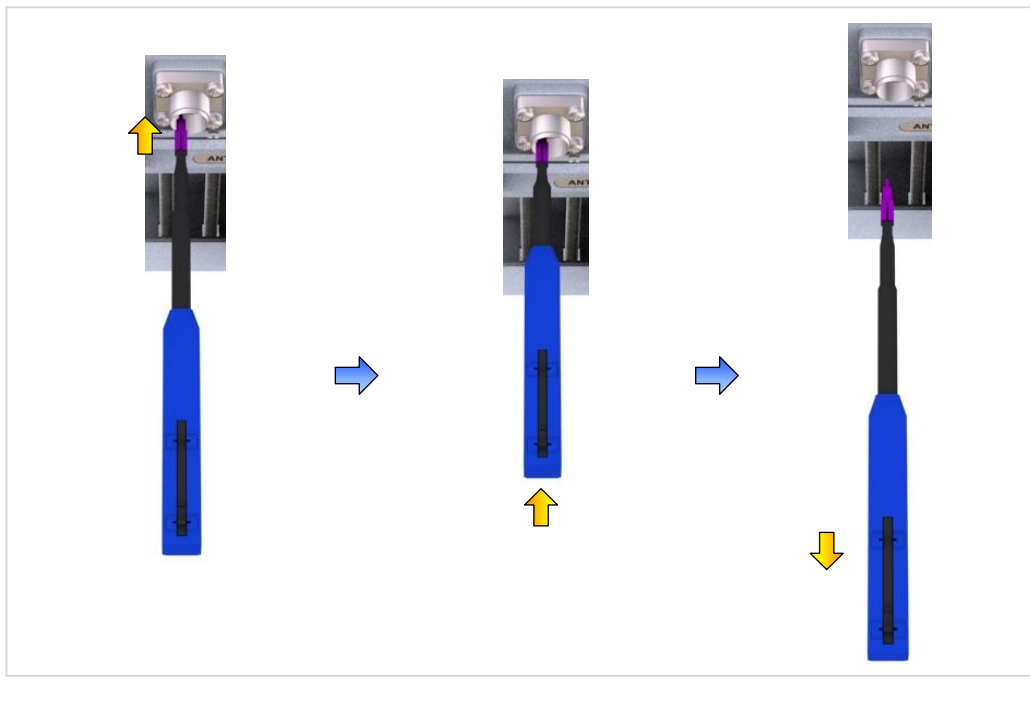
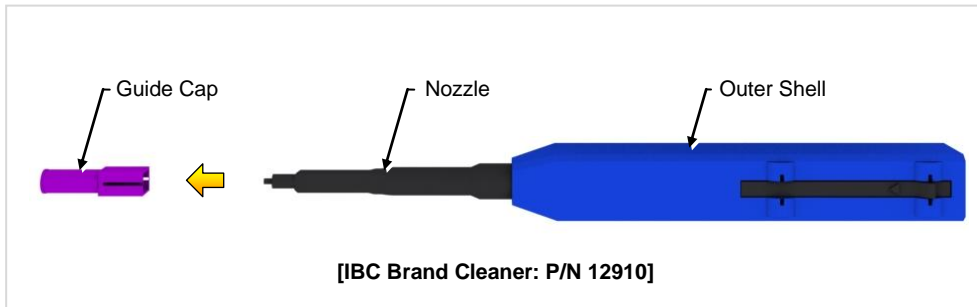

Figure D.5 Optic Port Cleaning (ODC, PT/LC Jack)

Optic Cable Connector Cleaning (ODC Type Plug)

- 1) To clean the ODC connector of cable, remove the guide cap from the cleaner (P/N: 12910).



- 2) Insert a cleaner guide cap to every core hole of the ODC connector. Clean it by pushing the outer shell toward the nozzle until you hear the sound of the detergent being sprayed. (Repeat once or twice.)

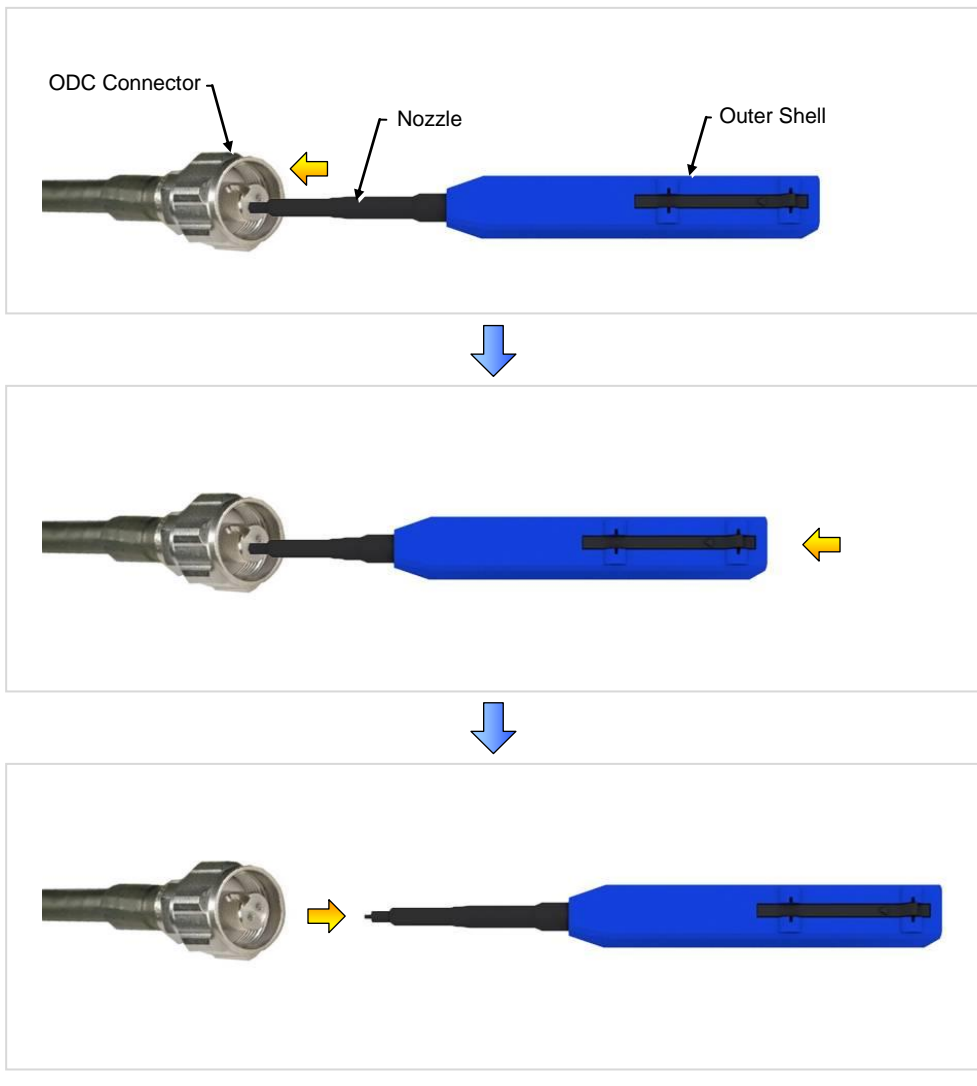
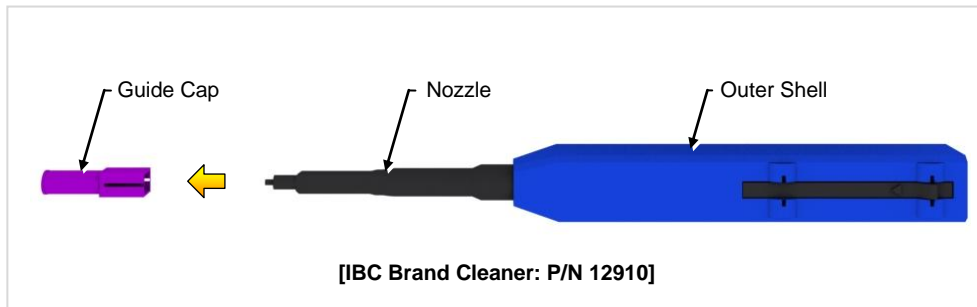

Figure D.6 Optic Cable Connector Cleaning (ODC Type Plug)

Optic Cable Connector Cleaning (PT/LC Type Plug)

- 1) To clean the PT/LC connector of cable, remove the guide cap from the cleaner (P/N: 12910).



- 2) Insert a cleaner guide cap to every core hole of the the PT/LC connector. Clean it by pushing the outer shell toward the nozzle until you hear the sound of the detergent being sprayed. (Repeat once or twice.)

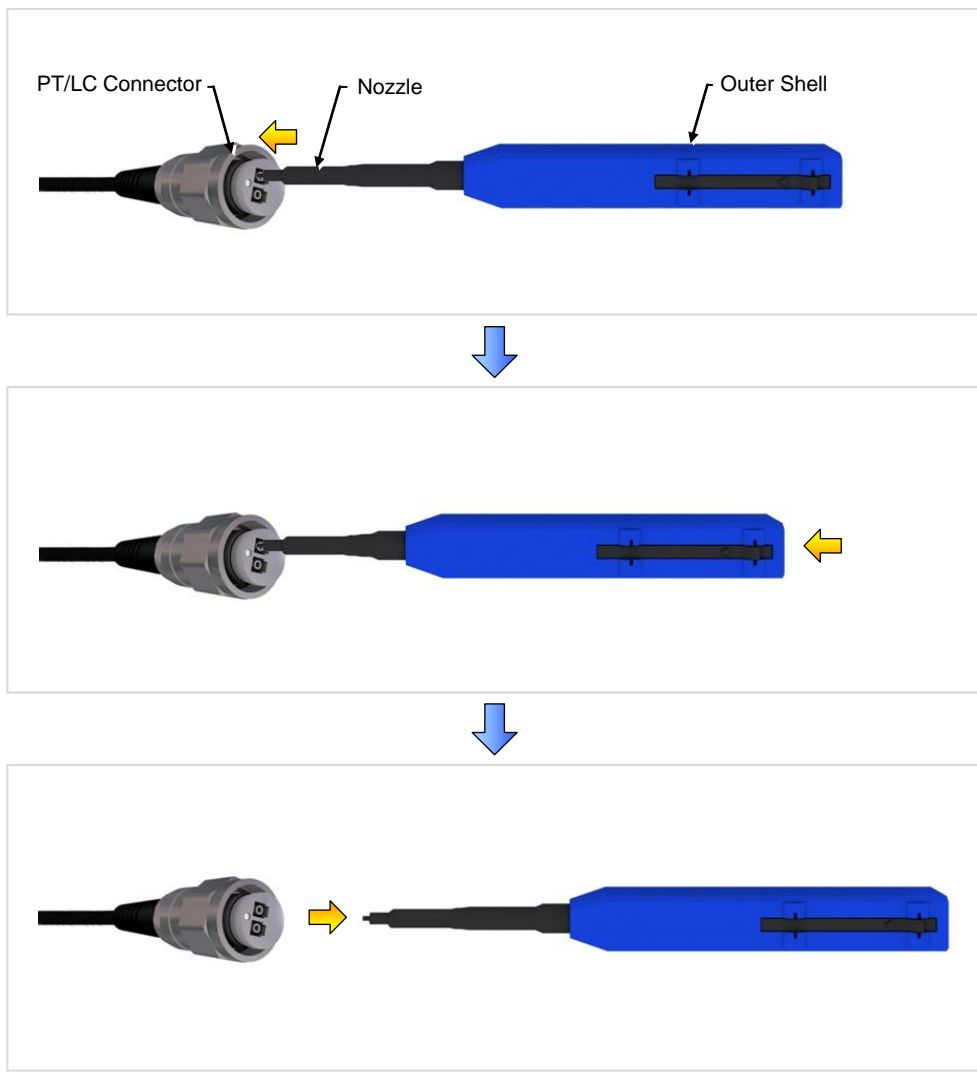
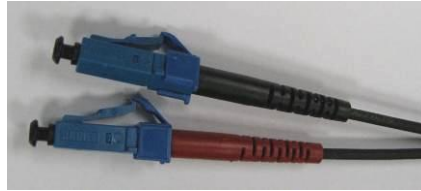

Figure D.7 Optic Cable Connector Cleaning (PT/LC Type Plug)

Measuring the Optical Output and Connecting the Optic Connector

- 1) Check the optical output again using an optic power meter.
- 2) If the optical output measurement result meets the reference value, clean the connector again and connect it. If the measurement result does not meet the reference value, discard the cable, replace it with a new cable, and then clean the new one and connect it to the system.



[LC/PC Plug]



[PT/LC Plug]



[ODC Plug]



[Harting Plug]



[Optic Powermeter]

Figure D.8 Measuring the Optical Output and Connecting the Optic Connector

ANNEX E. Pressure Terminal Assembly

Method that assembles the pressure terminal by using the crimp-type compressor is as follows:



Figure E.1 Pressure Terminal Assembly (1)

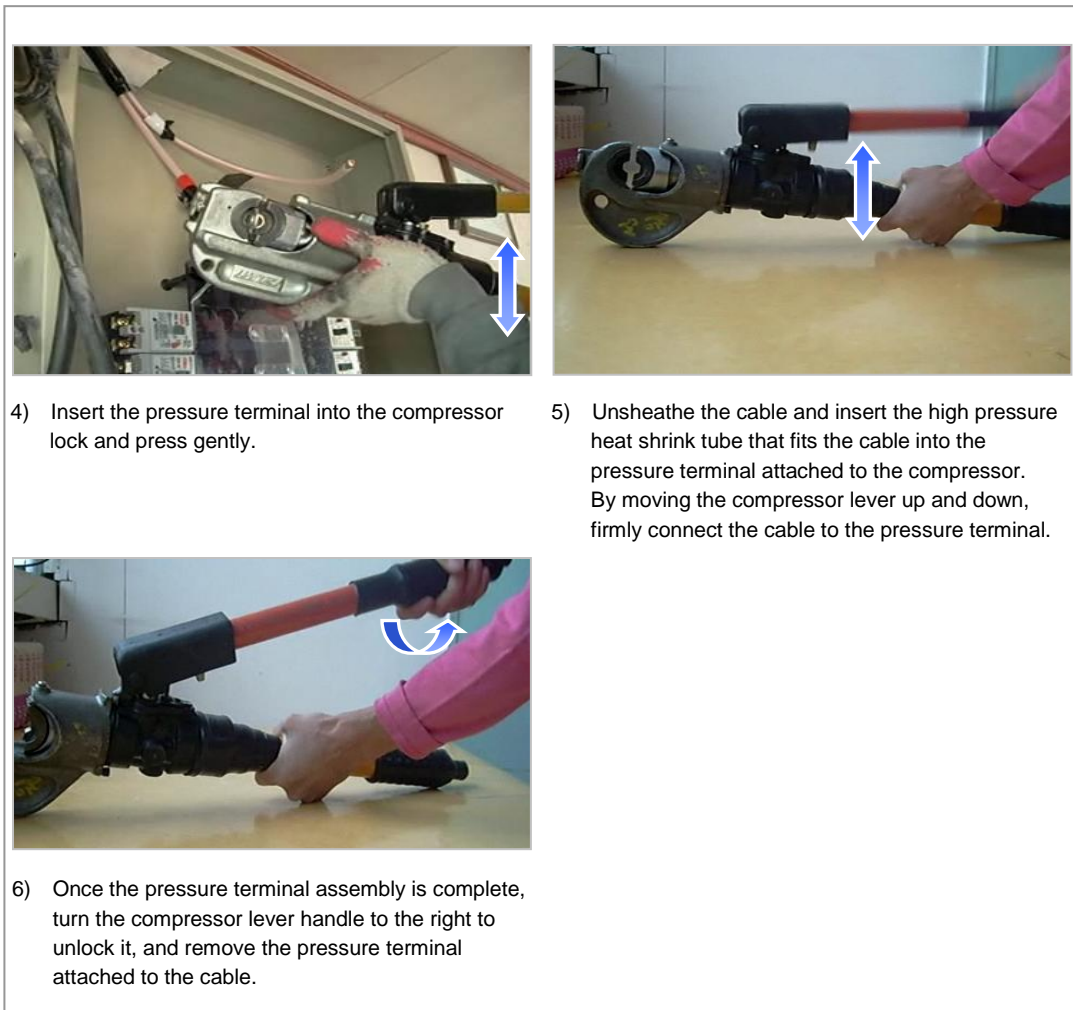

Figure E.2 Pressure Terminal Assembly (2)

Table E.1 Compressor Specification by Cable Thickness

Cable Spec. (mm ²)	Compressor Specification		
	Small-size Hand Compressor	Large-size Hand Compressor (AK-38, 100)	Hydraulic Compressor (IZUMI Hex. Type Dies)
2.5	2	X	X
4	2	X	X
6	5.5	X	X
10	8	8	X
16	14	14	16
25	22	22	25
35	38	38	35
50	X	60	50
70	X	80	70
95	X	100	95-300

ANNEX F. Standard Torque

When you tighten the bolt, refer to the standard torque value below to prevent the equipment and bolt from damage and secure by tightening. When the torque value for each connection part is defined already, refer to the defined value.

Table F.1 Standard Torque Value for Tightening Bolts

Bolt Spec.	Torque Value (kgf.cm)	Torque Value (lbf.ft)
M3	4.08~6.12	0.29~0.44
M4	9.52~14.28	0.69~1.03
M5	20.0~30.0	1.45~2.17
M6	33.28~49.92	2.41~3.61
M8	82.4~123.6	5.96~8.94
M10	166.4~249.6	12.03~18.05
M12	292.0~438.0	21.11~31.67



CHECK

Checking Standard Torque Value

Torque value can be different, depending on the material, characteristic and specification of the equipment and fixing material. Make sure to check the proper torque value for each specification of the equipment and fixing material.

ABBREVIATION

L

LTE Long Term Evolution

M

MGB Main Ground Bar
MIMO Multiple Input Multiple Output
MIP Mobile IP

N

NE Network Element

P

PIMD Passive Inter-Modulation Distortion

R

RSSI Received Signal Strength Indicator
RRH Remote RF Head

T

TGB Tower Ground Bar

V

VSWR Voltage Standing Waveform Ratio

Mobile WiMAX/TD-LTE RRH-2WB Installation Manual

©2012 Samsung Electronics Co., Ltd.

All rights reserved.

Information in this manual is proprietary to SAMSUNG
Electronics Co., Ltd.

No information contained here may be copied, translated,
transcribed or duplicated by any form without the prior written
consent of SAMSUNG.

Information in this manual is subject to change without notice.

