



Revision Date	20151014
Revision No.	0.0

User Manual

SWL - CQ52

802.11 b/g/n WLAN Module

Revision History

Revision	Date	Descriptions
0.0	2015-10-14	- Initial release

Table of Contents

1	GENERAL DESCRIPTION	4
1.1	FUNCTIONAL DESCRIPTION.....	4
1.2	FEATURES.....	4
1.2.3	BLOCK DIAGRAM.....	5
2	DIMENSION , PIN ASSIGNMENTS , PICTURES.....	6
2.1	DIMENSION	6
2.2	PIN ASSIGNMENTS	7
2.3	PICTURES	9
3	ELECTRICAL CHARACTERISTICS.....	10
3.1	ABSOLUTE MAXIMUM RATINGS	10
3.2	POWER CONSUMPTION	10
3.3	RECOMMENDED OPERATING CONDITIONS.....	10
3.4	ENVIRONMENTAL CHARACTERISTICS	10
4	RF SPECIFICATIONS	11
4.1	RECEIVER RF SPECIFICATIONS	11
4.2	TRANSMITTER RF SPECIFICATIONS.....	13
5.	PRODUCT LABEL INFORMATION	15
6.	MANUFACTURING SITE	16

1 General Description

1.1 Functional Description

SWL-CQ52 Module is a network protocol and Linux kernel based embedded wireless Full module. This module can be used for Smart appliance and a variety of applications such as standalone Wi-Fi AP or Station (**IEEE 802.11b/g/n , Main IC is QCA4531**)

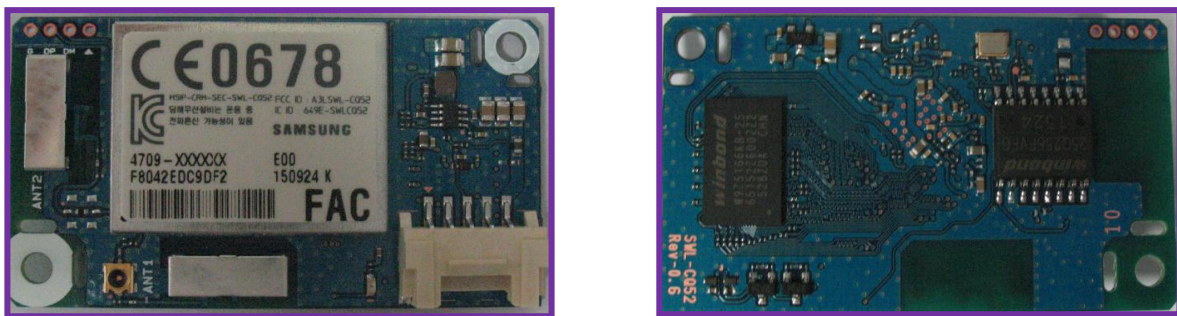

Figure 1-1 Module Picture

1.2 Features

- Consists of WiFi chipset which is QCA4531 for 2.4GHz band.
- Includes 1T2R MAC/BB/RF, high performance 550MHz MIPS R24 K CPU core
- Includes two 2.4GHz band Metal antennas (On-board)
- Compliant to IEEE 802.11b/g/n Wireless LAN Standards
- Supports standalone Wi-Fi AP or station for 2.4GHz band
- Supports 135Mbps PHY data rate for 2.4GHz band
- Supports 20MHz/40MHz channel bandwidth.
- Supports WEP 64/128, WPA, WPA2, TKIP, AES.
- Supports QOS – WMM, WMM Power Save.
- Supports UART Host Interface (12V level)
- Halogen free, RoHS Compliant.
- Manufacturing Site – SEMTHAI in Thailand

1.2.1 Power Management

- Supply voltage range
VCC 5V_12V (4.75V ~ 13.2V)
- Power Consumption
 - 11b 2.425W (@ Continuous Tx , 1Mbps , 18dBm)
T.B.D (@ Continuous Rx)
 - 11g 2.242W (@ Continuous Tx , 6Mbps , 16dBm)
T.B.D (@ Continuous Rx)
 - 11n 2.183W (@ Continuous Tx , MCS0 , 6.5Mbps , 13dBm)
T.B.D (@ Continuous Rx)

1.2.2 Applications

- Home appliances
(refrigerator , air conditioner , washing machine , electric oven , air cleaner)
- smart grid system
- Home energy management system solution
- Building energy management system solution
- Web server/client based IP-USN solution for Monitoring and Control

2 Dimension , Pin Assignments , Pictures

2.1 Dimension

2.1.1 Module Dimension

- Module : L X W X H = 54.0 x 30.0 x 7.34mm

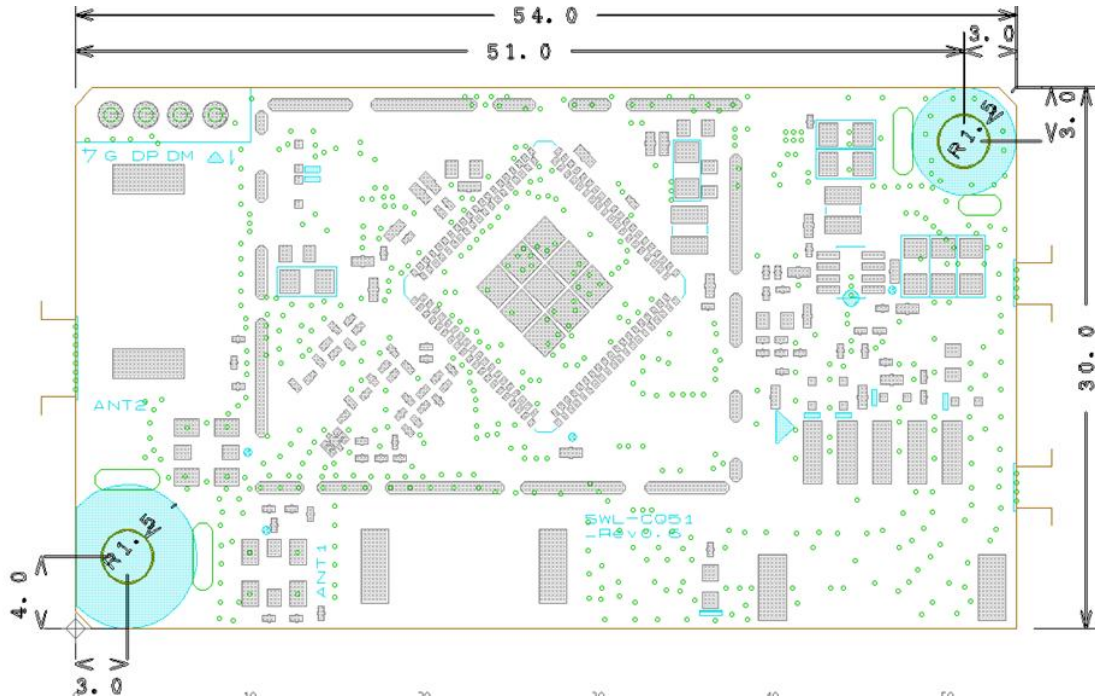

Figure 2-1 Array & Module Dimension

Parameter	Conditions	Min.	Nom.	Max.	Unit
Dimension (Module)					
X	-	-	54	-	mm
Y	-	-	30	-	mm
Height	-	-	7.34	-	mm

2.1.2 Antenna Dimension

ANT 1 & ANT 2 : 11.7(+/-0.3) x 4.0 (+/-0.3) x Hight Top 2.5 (+/-0.3)mm

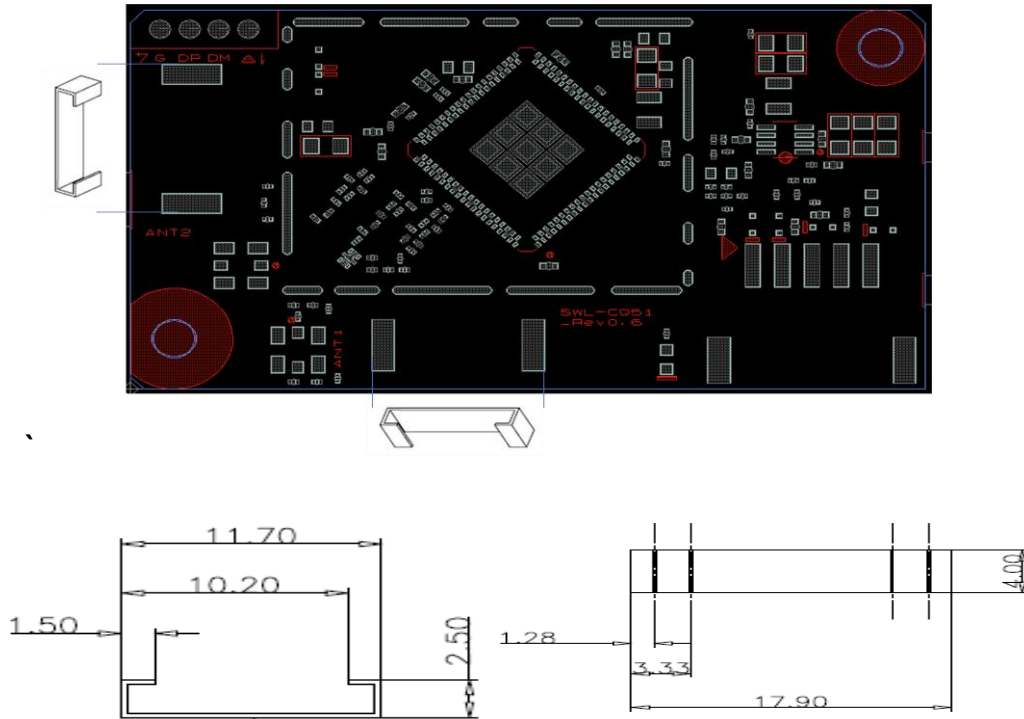

Figure 2-2 Antenna Mechanical Dimension

2.2 Pin Assignments

2.2.1 UART Interface

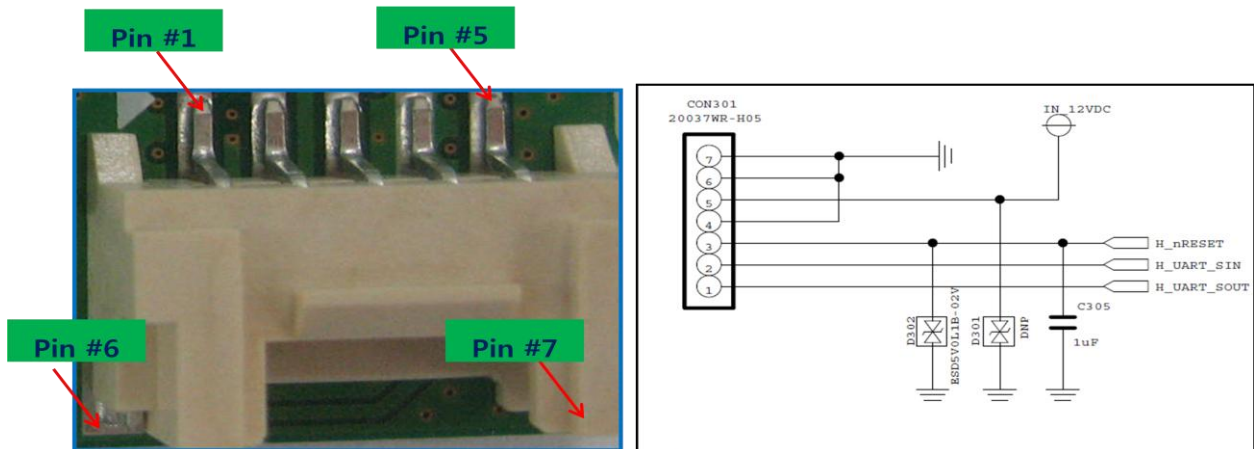

Figure 2-3 UART Pin Assignments (Top View)

No.	Pin Name	Description	Type
1	H_UART_SOUT	UART OUT	O
2	H_UART_SIN	UART IN	I
3	H_nRESET	Reset	O
4	GND	Ground	G
5	IN_12VDC	+12V Power supply for WIFI	P
6	GND	Ground	G
7	GND	Ground	G

2.2.2 USB Interface

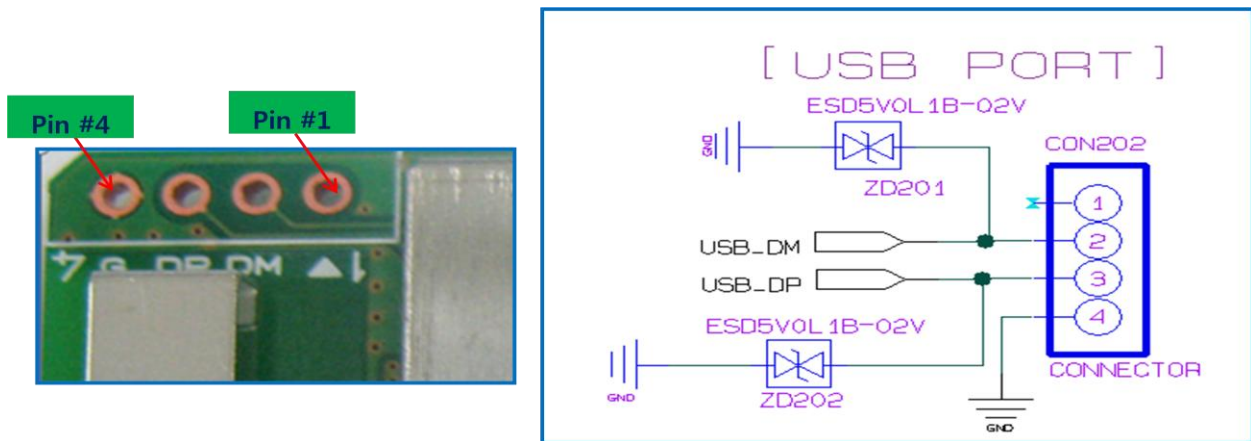

Figure 2-4 USB Pin Assignments (Top View)

No.	Pin Name	Description	Type
1	NC	NC	-
2	USB_DM	USB 2.0 D-	I/O
3	USB_DP	USB 2.0 D+	I/O
4	GND	Ground	G

2.3 Pictures

2.3.1 Picture

[Top Side]



[Bottom Side]

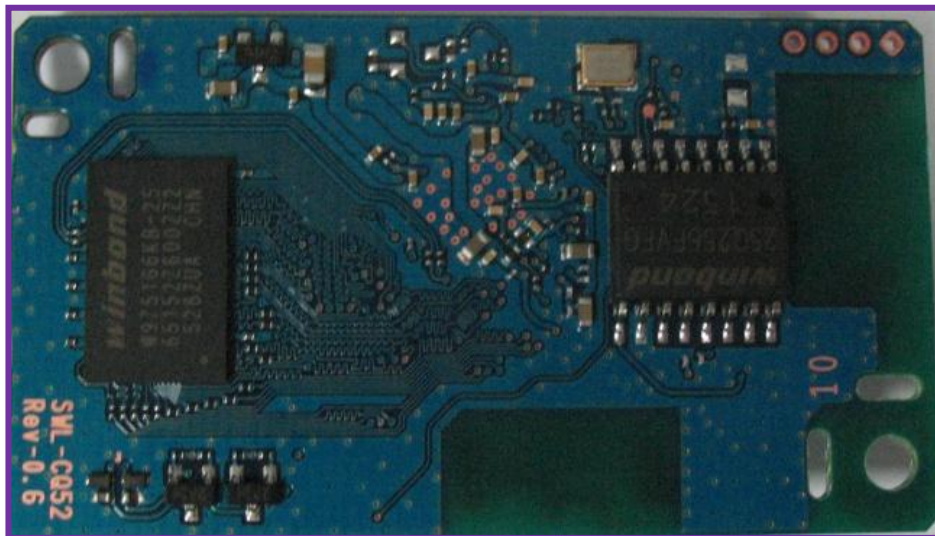

Figure 2-5 Module Picture

3 Electrical Characteristics

3.1 Absolute Maximum Ratings

Symbol	Parameter	Min.	Max.	Unit
VDD_5V_12V	DC supply voltage	4.75	+13.2	V

3.2 Power Consumption

Parameter	Conditions	Min.	Nom.	Max.	Unit
Tx mode (Max current)					
802.11b(2.4GHz)	12V, 18dBm Tx Power, 1Mbps		202.137		mA
802.11g(2.4GHz)	12V,16dBm Tx Power, 6Mbps		186.903		
802.11n(2.4GHz)_20MHz	12V,16dBm TX Power, MCS0		181.968		
802.11n(2.4GHz)_40MHz	12V,16dBm TX Power, MCS0		178.535		
Rx mode (Max current)					
802.11b/g/n(2.4GHz)	-		--		mA

Parameter	Conditions	Min.	Nom.	Max.	Unit
Tx mode (Max current)					
802.11b(2.4GHz)	5V, 18dBm Tx Power, 1Mbps		467.126		mA
802.11g(2.4GHz)	5V,16dBm Tx Power, 6Mbps		480.978		
802.11n(2.4GHz)_20MHz	5V,16dBm TX Power, MCS0		402.756		
802.11n(2.4GHz)_40MHz	5V,16dBm TX Power, MCS0		416.917		
Rx mode (Max current)					
802.11b/g/n(2.4GHz)	-		--		mA

3.3 Recommended Operating Conditions

Symbol	Parameter	Conditions	Min.	Nom.	Max.	Unit
VDD_5V	DC supply voltage from HOST	-	+4.75	+5 & +12	+13.2	V
Top	Operating temperature(Ambient)	-	0	-	+70	°C

3.4 Environmental Characteristics

Symbol	Parameter	Conditions	Min.	Max.	Unit
ESD	Electro-static discharge voltage	HBM	-4K	+4K-	V
Top	Operating temperature	-	0	+70	°C
Tstg	Storage temperature	-	-30	+85	°C

4 RF Specifications

All measurements are made under nominal supply voltage, room temperature, and conducted conditions at each antenna port except antenna.

4.1 Receiver RF Specifications

Parameter	Conditions	Min.	Nom.	Max.	Unit	
Receive input frequency (based on center frequency of channel)						
802.11b/g/n	2.4GHz	2412	-	2472	MHz	
Receiver sensitivity						
802.11b	1Mbps	PER<8%, Packet size= 1,024bytes	-	-	-80*	dBm
	2Mbps		-	-	-80*	dBm
	5.5Mbps		-	-	-76*	dBm
	11Mbps		-	-	-76*	dBm
802.11g	6Mbps	PER<10%, Packet size= 1,024bytes	-	-	-82*	dBm
	9Mbps		-	-	-81*	dBm
	12Mbps		-	-	-79*	dBm
	18Mbps		-	-	-77*	dBm
	24Mbps		-	-	-74*	dBm
	36Mbps		-	-	-70*	dBm
	48Mbps		-	-	-66*	dBm
54Mbps	-	-	-65*	dBm		
802.11n (HT20)	MCS0 / MCS8	PER<10%, Packet size= 1,024bytes	-	-	-82*	dBm
	MCS1 / MCS9		-	-	-79*	dBm
	MCS2 / MCS10		-	-	-77*	dBm
	MCS3 / MCS11		-	-	-74*	dBm
	MCS4 / MCS12		-	-	-70*	dBm
	MCS5 / MCS13		-	-	-66*	dBm
	MCS6 / MCS14		-	-	-65*	dBm
MCS7 / MCS15	-	-	-64*	dBm		
802.11n (HT40)	MCS0 / MCS8	PER<10%, Packet size= 1,024bytes	-	-	-79*	dBm
	MCS1 / MCS9		-	-	-76*	dBm
	MCS2 / MCS10		-	-	-74*	dBm
	MCS3 / MCS11		-	-	-71*	dBm
	MCS4 / MCS12		-	-	-67*	dBm

	MCS5 / MCS13		-	-	-63*	dBm
	MCS6 / MCS14		-	-	-62*	dBm
	MCS7 / MCS15		-	-	-61*	dBm

Maximum input level						
802.11b	PER<8%		-10*	-	-	dBm
802.11g/n(2.4GHz)	PER<10%		-20*	-	-	dBm

"*" Indicate IEEE spec

4.2 Transmitter RF Specifications

Parameter	Conditions	Min	Nom	Max	Unit
Transmit output frequency (Center frequency of channel)					
802.11b/g/n	2.4GHz	2412	-	2472	MHz
Transmit Channel Power*					
802.11b (2.4GHz)	1~11Mbps	15.5	18	20.5	dBm
802.11g (2.4GHz)	6~24Mbps	13.5	16	18.5	dBm
	36Mbps	12.5	15	17.5	dBm
	48Mbps, 54Mbps	11.5	14	16.5	dBm
802.11n (2.4GHz) (HT20)	MCS0	11.5	16	18.5	dBm
	MCS1~MCS5	10.5	15	17.5	dBm
	MCS6	11.5	14	16.5	dBm
	MCS7	10.5	13	15.5	dBm
802.11n (2.4GHz) (HT40)	MCS0	13.5	16	18.5	dBm
	MCS1~MCS3	12.5	15	17.5	dBm
	MCS4,MCS5	11.5	14	16.5	dBm
	MCS6	10.5	13	15.5	dBm
	MCS7	9.5	12	14.5	dBm
Spectrum mask					
802.11b	Fc ±11MHz to ±22MHz	-	-	-30	dBr
	Fc ±22MHz and more	-	-	-50	dBr
802.11g	Fc ±11MHz	-	-	-20	dBr
	Fc ±20MHz	-	-	-28	dBr
	Fc ±30MHz	-	-	-40	dBr
802.11n	Fc ±11MHz/±21MHz @ HT20/HT40	-	-	-20	dBr
	Fc ±20MHz/±40MHz @ HT20/HT40	-	-	-28	dBr
	Fc ±30MHz/±60MHz @ HT20/HT40	-	-	-45	dBr
Center Frequency tolerance					
802.11b	2.4GHz	-25	-	+25	ppm

802.11g	2.4GHz	-25	-	+25	ppm	
802.11n	2.4GHz	-25	-	+25	ppm	
EVM(Error Vector Magnitude)**						
802.11b	1Mbps	As specified in IEEE802.11b	-	-	35	%
	2Mbps		-	-	35	%
	5.5Mbps		-	-	35	%
	11Mbps		-	-	35	%
802.11g	6Mbps	Mandatory	-	-	-5	dB
	9Mbps	Optional	-	-	-8	dB
	12Mbps	Mandatory	-	-	-10	dB
	18Mbps	Optional	-	-	-13	dB
	24Mbps	Mandatory	-	-	-16	dB
	36Mbps	Optional	-	-	-19	dB
	48Mbps	Optional	-	-	-22	dB
	54Mbps	Optional	-	-	-25	dB
802.11n	MCS0		-	-	-5	dB
	MCS1		-	-	-10	dB
	MCS2		-	-	-13	dB
	MCS3		-	-	-16	dB
	MCS4		-	-	-19	dB
	MCS5		-	-	-22	dB
	MCS6		-	-	-25	dB
	MCS7		-	-	-27	dB
Remarks						
<p>* Transmit Channel Power : Transmit channel power is limited within EIRP limit based on country regulation in operational mode.</p> <p>** EVM : <Test condition> . Method: composite EVM method. . Number of symbols: 17. . Phase correction: Symbol-by-symbol correction. . Channel estimation: Raw channel estimate full packet. . Symbol timing correction: on. . Amplitude tracking: off. . Frequency Sync: Long training symbol.</p>						

5. Product Label Information

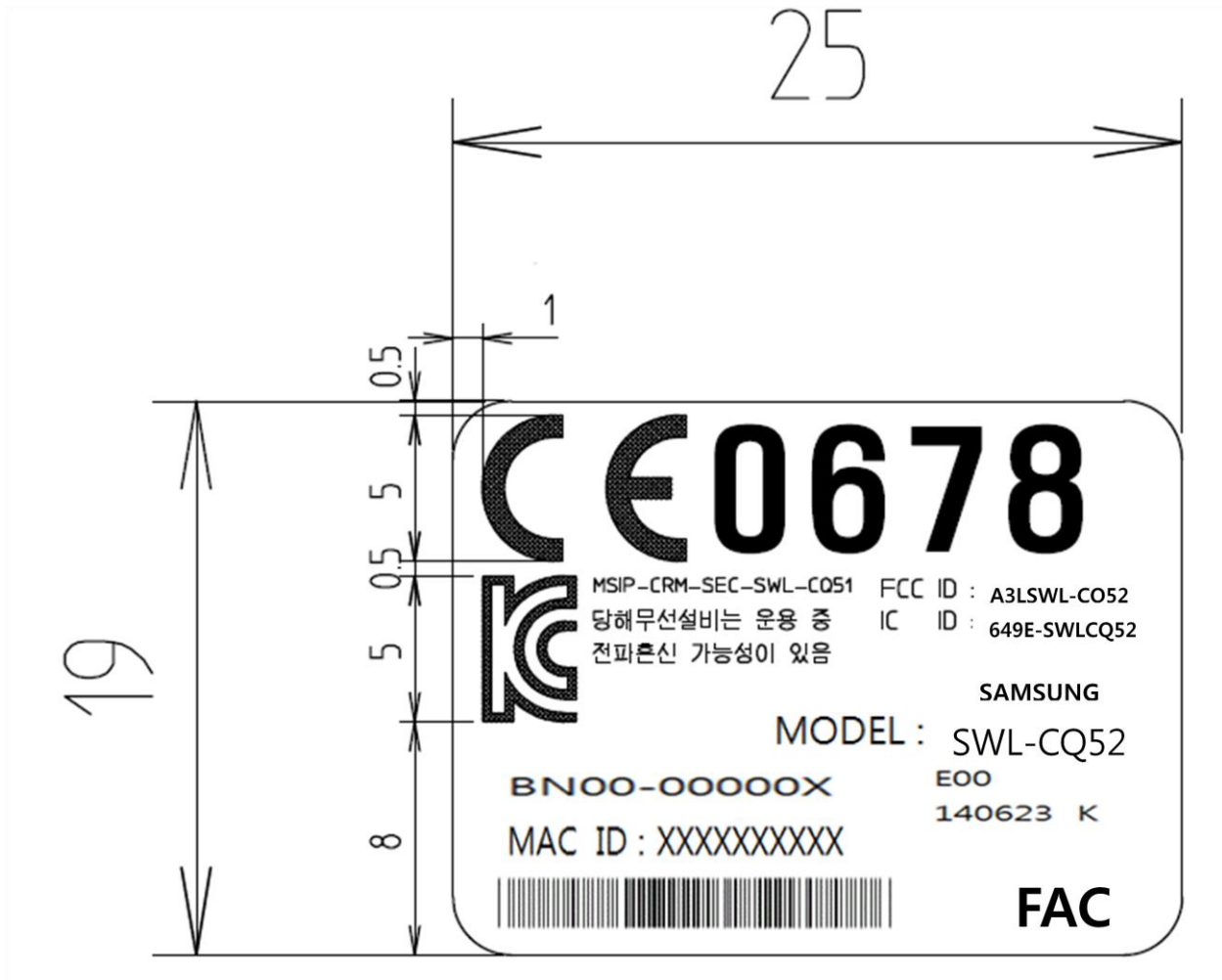

Figure 5-1. Product Label

6. Manufacturing Site

Samsung Electro-mechanics Thailand Co., Ltd. (SEMTHAI)
Wellgrow Industrial Estate, 93 Moo 5 T. Bangsamak, A.Bangpakong,
Chachoengsao 24180 THAILAND

Tel. : 66-38-562-000

Fax No. : 66-38-562-177

Instruction to OEM

This device complies with Industry Canada's license-exempt RSSs. Operation is subject to the following two conditions:

- (1) This device may not cause interference and
- (2) This device must accept any interference, including interference that may cause undesired operation of the device.

This application and its antenna must not be co-located or operation in conjunction with any other antenna or transmitter. A minimum separation distance of 20cm must be maintained between the antenna and the person for this appliance to satisfy the RF exposure requirements.

Host labeling requirement: "Contains transmitter module

FCC ID: A3LSWL-CQ52
IC ID: 649E-SWLCQ52"

This device complies with part 15 of the FCC Rules.
Operation is subject to the following two conditions:

- (1) This device may not cause harmful interference and
- (2) this device must accept any interference received, including interference that may cause undesired operation.

Le présent appareil est conforme aux CNR d'Industrie Canada applicables aux appareils radio exempts de licence. L'exploitation est autorisée aux deux conditions suivantes:

- (1) l'appareil ne doit pas produire de brouillage, et
- (2) l'utilisateur de l'appareil doit accepter tout brouillage radioélectrique subi, même si le brouillage est susceptible d'en compromettre le fonctionnement.