

Introduction

What is WEA453e?

The WEA453e is an outdoor Wireless Enterprise AP that supports 802.11ac specifications. It connects the UE that supports wireless LAN, such as a smartphone, tablet, or notebook, to a wired network in an outdoor environment.

The WEA453e supports the following features:

- IEEE 802.11a/b/g/n/ac standard
- Power over Ethernet (PoE) IEEE 802.3af/802.3at
- 3 x 3 Multiple Input Multiple Output (MIMO)
- Wireless LAN through both 2.4 GHz and 5 GHz bandwidths
- Temperature Range: -40~+55°C
- Environment Condition: IP67

Components

After unpacking the WEA453e, confirm that all of the following items have been included:

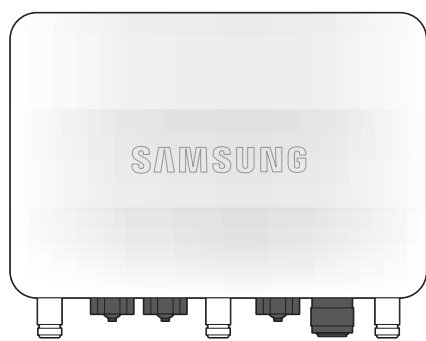

Front

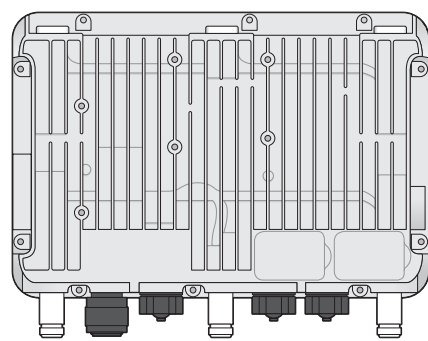

Rear

Common Components

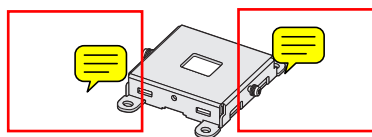

Mount Bracket

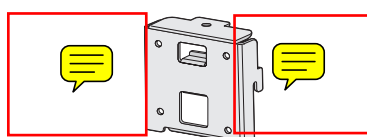

Unit Bracket



6 M4 x L10 Screws



Quick Start Guide

Wall-Mount Installation Materials



5 plastic Anchors



5 M4 x L25 Screws



It is recommended that you keep the box and all of the packing materials.

Name and Function

Side

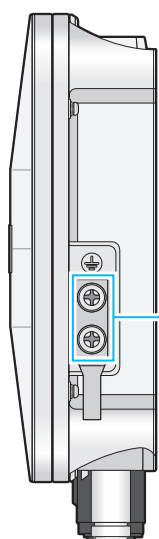

Ground Wire

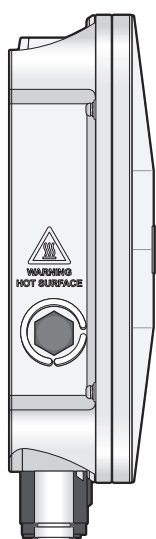

Base

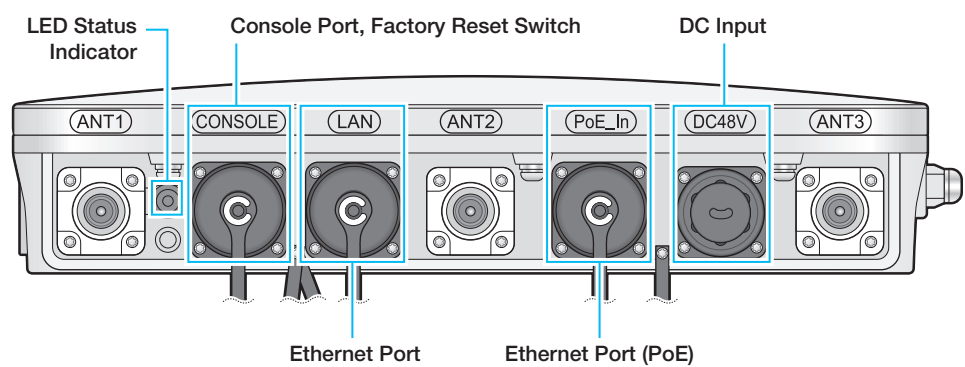

Interface

Interface	Description
LED Status	Displays the status information of WEA453e using an LED.
DC Input	Connects the power adaptor.
Ethernet Port (PoE)	Supports a 1000 BASE-T Gigabit Ethernet and PoE IEEE 802.3af/802.3at connection.
Console Port	Used to check the operational status of the WEA453e and to input the CLI.
Factory Reset Switch	Used to switch the WEA453e to the initial factory settings.

LED Status Indicator

LED	Status	Description
System Start	White	Initial LED status
	Blue	Device reset and diagnostic test in progress
	Red	Booting failure (device reset failure)
Provisioning	Repeating red and green	Connecting APC (network link normal)
	Blinking green	Connecting CAPWAP (APC server connection status normal)
Normal Operations	Green	No wireless UE connected
	Blue	Wireless UE connected
Upgrade	Blinking blue	Upgrading software
Failure	Blinking red	Network connection failure (physical)
	Blinking orange	IP address conflict
	Blinking violet	Dynamic IP address allocation failure
	Blinking bluish green	Network connection failure (logical)
	Repeating Red and Blue	Wireless interface failure

Installation

The WEA453e can be installed on a pole or on a wall.

Please confirm that all of the components have been included before installation.

Before Installation

Safety Requirements

Carefully observe the following safety warnings in order to avoid the risk of damage or injury. Always follow these safety precautions when using the product.



- There is a risk of electrical shock. Make sure that the power is turned off during installation. Do not proceed with the installation if there is any electrical current leaking. It may cause a serious electric shock.
- Wear anti-static gloves or take an appropriate action to prevent ESD when handling the product.
- Do not connect a phone line to an Ethernet port. This may damage the product.
- This product must be connected to a power supply in compliance with IEEE 802.3af/at or connected to a limited power supply in compliance with IEC/EN/UL 60950-1.



- This product must be installed or removed by only appropriately trained service personnel.
- For outdoor use or installation outdoors. For more details, refer to "Environment" in the IEEE 802.3af/at standards.
- This product must be installed at least 3 m or further away from a WiBro/3G/4G repeater or antenna.

Safety Instructions



Do Not Wear Metal Accessories

Be careful not to short-circuit the power line with any metal accessories that you may be wearing, such as a watch or ring.



Using Megger Test Equipment

When using Megger test equipment, keep in mind the following safety precautions to prevent an electric shock:

- Connect Earth COM (black) and AC.V (red) lead wires with the correct polarities. At this point, make sure not to touch the connected probe (reading part of the lead wire) with your hand or any other physical object.
- While measuring the insulation resistance, never touch the system.



Connecting the Ground Cable

When connecting the cables, make sure to connect the ground cable first. When in contact with the system, while connecting the cable or while maintaining the system without the ground cable connected, the system can be damaged due to static electricity and thereby short-circuit, which could result in an electric shock to the operator.



Turn Off the Circuit Breaker

Since the circuit breaker of the AC Distribution Box is required to supply power to the system through the connected power cable, make sure that the circuit breaker switch on the AC Distribution Box is turned off (open) when connecting the power connector. If you install the system with the circuit breaker turned on, it may cause irrevocable damage to the system and fatally injure the operator at the time when the cable is incorrectly connected.



Access can only be gained by SERVICE PERSONS or by USERS who have been instructed about the reasons for the restrictions applied to the location and about any precautions that shall be taken; and access is through the use of a TOOL or lock and key, or other means of security, and is controlled by the authority responsible for the location.



Notice! Be careful not to touch the Heat-sink part due to high temperature.



Round terminals located on the side of a 0.75 mm² (18 AWG) or more wires Using permanently connected to earth.



Measuring the Insulation Resistance

Because of the high voltage used while measuring insulation resistance, carefully adhere to the following safety measures in order to prevent serious injury and system damage:

- Disconnect all of the cables connected to the system before measuring the insulation resistance.
- Do not measure the insulation resistance when the power is live.
- Do not measure the insulation resistance of the units and parts inside the system except for those designated.



Grounding the System

MGBs for use as a lightning arrester, for power, or for communication, should be separated. These 3 types of MGBs can be grounded by the isolation grounding system, or by the common grounding system, after branching at the installed mesh underground.



Installing the Antenna

For lightning protection, the antenna must be installed within the protection angle of the lightning arrester (45° both to the left and to the right of the central axis).



Cleaning the Power Supply

When cleaning the power supply, it should not be interrupted as a result of any contact.

Installation Instructions

The following instructions must be carefully observed during installation.

- The system must be easily accessible for product installation, cable connections, or maintenance.
- The PoE LAN cable must always be installed away from an electrical interference source, such as a power line, fluorescent light, radio, or transmitter.
- The PoE LAN cable should be a Shielded Twisted Pair (STP) cable at CAT 5E or higher.
- If the PoE is not easy to use, a power adapter (sold separately) can be attached. The 3-pin (including ground) power that supplies 100~240 V AC, 50~60 Hz, must be located within 2 m from the equipment and the power must be supplied through an independent circuit breaker. Equipment that uses a filter or surge breaker is recommended.

This equipment has been tested and found to comply with the limits for a Class B digital device, pursuant to part 15 of the FCC Rules. These limits are designed to provide reasonable protection against harmful interference in a residential installation.

This equipment generates, uses and can radiate radio frequency energy and, if not installed and used in accordance with the instructions, may cause harmful interference to radio communications.

However, there is no guarantee that interference will not occur in a particular installation. If this equipment does cause harmful interference to radio or television reception, which can be determined by turning the equipment off and on, the user is encouraged to try to correct the interference by one or more of the following measures:

- Reorient or relocate the receiving antenna.
- Increase the separation between the equipment and receiver.
- Connect the equipment into an outlet on a circuit different from that to which the receiver is connected.
- Consult the dealer or an experienced radio/TV technician for help.



Changes or modifications not expressly approved by the party responsible for compliance could void the user's authority to operate the equipment.

This device complies with Industry Canada licence-exempt RSS standard(s).

Operation is subject to the following two conditions:

(1) this device may not cause interference, and (2) this device must accept any interference, including interference that may cause undesired operation of the device.

Le présent appareil est conforme aux CNR d'Industrie Canada applicables aux appareils radio exempts de licence.

L'exploitation est autorisée aux deux conditions suivantes:

(1) l'appareil ne doit pas produire de brouillage, et (2) l'utilisateur de l'appareil doit accepter tout brouillage radioélectrique subi, même si le brouillage est susceptible d'en compromettre le fonctionnement.

FCC RF Radiation Exposure Statement:

This equipment complies with FCC RF radiation exposure limits set forth for an uncontrolled environment.

This equipment should be installed and operated with a minimum distance of 50 cm between the radiator and your body.

This transmitter must not be co-located or operating in conjunction with any other antenna or transmitter.

RSS-102 RF Exposure

L'antenne (ou les antennes) doit être installée de façon à maintenir à tout instant une distance minimum de au moins 50 cm entre la source de radiation (l'antenne) et toute personne physique. Cet appareil ne doit pas être installé ou utilisé en conjonction avec une autre antenne ou émetteur.

WEEE SYMBOL INFORMATION



This marking on the product, accessories or literature indicates that the product and its electronic accessories (e.g. charger, headset, USB cable) should not be disposed of with other household waste at the end of their working life. To prevent possible harm to the environment or human health from uncontrolled waste disposal, please separate these items from other types of waste and recycle them responsibly to promote the sustainable reuse of material resources.

Household users should contact either the retailer where they purchased this product, or their local government office, for details of where and how they can take these items for environmentally safe recycling.

Business users should contact their supplier and check the terms and conditions of the purchase contract.

This product and its electronic accessories should not be mixed with other commercial wastes for disposal.

Electromagnetic Wave Suitability Notice

Class B Equipment (For Home Use Broadcasting & Communication Equipment)

This product is home use (Class B) electromagnetic wave suitability equipment designed to be used in all areas of the home.

Caution

Wireless equipment may interfere with radio waves while operating. Services related to safety of life cannot be provided.