

# SAMSUNG

# USER MANUAL

---

WM55H

The color and the appearance may differ depending on the product, and the specifications are subject to change without prior notice to improve the performance.

The contents of this manual are subject to change without notice to improve quality.

© Samsung Electronics

Samsung Electronics owns the copyright for this manual.

Use or reproduction of this manual in parts or entirety without the authorization of Samsung Electronics is prohibited.

Trademarks other than that of Samsung Electronics are owned by their respective owners.

---

# Table of contents

## Before Using the Product

Safety Precautions	4
Storage	4
Electricity and Safety	4
Installation	5
Operation	6
Precautions for use	8

## Preparations

Checking the Components	9
Parts	10
Ports	11
Before Installing the Product (Installation Guide)	12
Rotation	12
Ventilation	12
Installing the Wall Mount	14
Installing the Wall Mount	14
Wall Mount Kit Specifications (VESA)	14
Connecting to a network	15
Network Settings (Wired)	15
Network Settings (Wireless)	17
Use WPS	19

## Screen Elements

### Create

Drawing / Eraser	21
Changing the pen thickness	21
Changing the pen color	21
Eraser	21
Managing Rolls	22
OPEN	23
Page Viewer	24

### IMPORT

Connecting to a Mobile Device	26
Connecting using screen mirroring	26
Connecting using NFC tagging	26
Connecting to a Laptop	27
Connecting using a cable	27
Connecting using a screen mirroring	27
Importing from a USB Device	28
Importing from a Network Drive	28
PIP screen	29

## EXPORT

E-MAIL	31
PRINT	32
NetPrinting Server Program Installation	32
Setting up the printer	32
Exporting to a USB Device	34
Exporting from a Network Drive	34

## Menu

Pen	35
Connect	36
System	37
Picture	38
Support	39

## Troubleshooting Guide

Check the followings.	40
-----------------------	----

---

# Table of contents

## Specifications

---

General	45
Preset Timing Modes	47

## Appendix

---

Responsibility for the Pay Service (Cost to Customers)	49
Not a product defect	49
A Product damage caused by customer's fault	49
Others	49
Optimum Picture Quality and Afterimage Burn-in Prevention	50
Optimum Picture Quality	50
Prevention of Afterimage Burn-in	50
License	52

# Chapter 01

## Before Using the Product

### Safety Precautions

#### Warning

A serious or fatal injury may result if instructions are not followed.

#### Caution

Personal injury or damage to properties may result if instructions are not followed.



Activities marked by this symbol are prohibited.



Instructions marked by this symbol must be followed.









### Storage

Due to the characteristics of high-glossy products, using a UV humidifier nearby may create white-colored stains on the product.

 Contact Customer Service Center if the inside of the product needs cleaning (service fee will be charged).





### Electricity and Safety

#### Warning

-  Do not use a damaged power cord or plug, or a loose power socket. An electric shock or fire may result.
-  Do not use multiple products with a single power socket. Overheated power sockets may cause a fire.
-  Do not touch the power plug with wet hands. Otherwise, an electric shock may result.
-  Connect the power plug to a grounded power socket (type 1 insulated devices only). An electric shock or injury may result.
-  Do not bend or pull the power cord with force. Be careful not to leave the power cord under a heavy object. Damage to the cord may result in a fire or electric shock.
-  Insert the power plug all the way in so it is not loose. An unsecure connection may cause a fire.
-  Connect the power plug to a grounded power socket (type 1 insulated devices only). An electric shock or injury may result.
-  Clean any dust around the pins of the power plug or the power socket with a dry cloth. A fire may result.









---

## Caution

-  Do not disconnect the power cord while the product is being used.  
The product may become damaged by an electric shock.
-  Only use the power cord provided with your product by Samsung. Do not use the power cord with other products.  
A fire or electric shock may result.
-  Keep the power socket where the power cord is connected unobstructed.
  - The power cord must be disconnected to cut off power to the product when an issue occurs.
  - Note that the product is not completely powered down by using only the power button on the remote.
-  Hold the plug when disconnecting the power cord from the power socket.  
An electric shock or fire may result.





## Installation

### Warning

-  DO NOT PLACE CANDLES, INSECT REPELLANTS OR CIGARETTES ON TOP OF THE PRODUCT. DO NOT INSTALL THE PRODUCT NEAR HEAT SOURCES.  
A fire may result.
-  Do not install the product on an unstable or vibrating surface (insecure shelf, sloped surface, etc.)
  - The product may fall and become damaged and/or cause an injury.
  - Using the product in an area
-  Do not expose the product to direct sunlight, heat, or a hot object such as a stove.  
The product lifespan may be reduced or a fire may result.
-  Do not install the product within the reach of young children.
  - The product may fall and injure children.
  - As the front is heavy, install the product on a flat and stable surface.
-  Edible oil, such as soybean oil, can damage or deform the product. Do not install the product in a kitchen or near a kitchen counter.
-  Have a technician install the wall-mount hanger.
  - Installation by an unqualified person can result in an injury.
  - Only use approved cabinets.
-  Keep the plastic packaging out of the reach of children.  
Children may suffocate.
-  Do not install the product in a vehicle or a place exposed to dust, moisture (water drips, etc.), oil, or smoke.  
A fire or electric shock may result.







---

## Caution

-  Do not set down the product on its front.  
The screen may become damaged.
-  When installing the product on a cabinet or shelf, make sure that the bottom edge of the front of the product is not protruding.
  - The product may fall and become damaged and/or cause an injury.
  - Install the product only on cabinets or shelves of the right size.
-  Set down the product gently.  
Product failure or personal injury may result.
-  Installing the product in an unusual place (a place exposed to a lot of fine dust, chemical substances, extreme temperatures or a significant presence of moisture, or a place where the product will operate continuously for an extended period of time) may seriously affect its performance.  
Be sure to consult Samsung Customer Service Center if you want to install the product at such a place.

## Operation

### Warning

-  There is a high voltage inside the product. Never disassemble, repair or modify the product yourself.
  - A fire or electric shock may result.
  - Contact Samsung Customer Service Center for repairs.
-  Do not let children hang from the product or climb on top of it.  
Children may become injured or seriously harmed.
-  If the product is dropped or the outer case is damaged, turn off the power switch and disconnect the power cord. Then contact Samsung Customer Service Center.  
Continued use can result in a fire or electric shock.
-  Do not leave heavy objects or items that children like (toys, sweets, etc.) on top of the product.  
The product or heavy objects may fall as children try to reach for the toys or sweets resulting in a serious injury.
-  Do not move the product by pulling the power cord or any cable.  
Product failure, an electric shock or fire may result from a damaged cable..
-  Do not lift or move the product by pulling the power cord or any cable.  
Product failure, an electric shock or fire may result from a damaged cable.
-  Ensure the vents are not blocked by tablecloths or curtains.  
An increased internal temperature may cause a fire.

 Do not insert metallic objects (chopsticks, coins, hairpins, etc) or objects that burn easily (paper, matches, etc) into the product (via the vent or input/output ports, etc).

- Be sure to power off the product and disconnect the power cord when water or other foreign substances have entered the product. Then contact Samsung Customer Service Center.
- Product failure, an electric shock or fire may result.

 Do not place objects containing liquid (vases, pots, bottles, etc) or metallic objects on top of the product.

- Be sure to power off the product and disconnect the power cord when water or other foreign substances have entered the product. Then contact Samsung Customer Service Center.
- Product failure, an electric shock or fire may result.

 Before moving the product, turn off the power switch and disconnect the power cable and all other connected cables.

Damage to the cord may result in a fire or electric shock.

 If the product generates abnormal sounds, a burning smell or smoke, disconnect the power cord immediately and contact Samsung Customer Service Center.

An electric shock or fire may result.

 During a lightning or thunderstorm, power off the product and remove the power cable.

A fire or electric shock may result.

 Do not drop objects on the product or apply impact.

A fire or electric shock may result.

 If a gas leakage is found, do not touch the product or power plug. Also, ventilate the area immediately.

Sparks can cause an explosion or fire.

## Caution

 Do not hold the product upside-down or move it by holding the stand.

The product may fall and become damaged or cause an injury.

 Do not use humidifiers or stoves around the product.

A fire or electric shock may result.

 Do not place heavy objects on the product.

Product failure or personal injury may result.

 Do not touch the screen when the product has been turned on for an extended period of time as it will become hot.

 Leaving the screen fixed on a stationary image for an extended period of time may cause afterimage burn-in or defective pixels.

Activate power-saving mode or a moving-picture screen saver if you will not be using the product for an extended period of time.

 Disconnect the power cord from the power socket if you do not plan on using the product for an extended period of time (vacation, etc).

Dust accumulation combined with heat can cause a fire, electric shock or electric leakage.

 Use the product at the recommended resolution and frequency.

Your eyesight may deteriorate.

 Looking at the screen too close for an extended period of time can deteriorate your eyesight.

 Rest your eyes for more than 5 minutes for every 1 hour of product use.

Eye fatigue will be relieved.

 Store small accessories out of the reach of children.

- 
- ⚠ Exercise caution when adjusting the product angle or stand height.
    - Your hand or finger may get stuck and injured.
    - Tilting the product at an excessive angle may cause the product to fall and an injury may result.
  - ⚠ Do not use or keep combustible spray or an inflammable substance near the product.  
An explosion or fire may result.

## Precautions for use

Be careful that if you use the supplied pen with a load exceeding 2.5kg, scratches may occur on the protective glass.

If you use a ballpoint pen other than the supplied pen, be careful that the screen may be stained with ink or damaged.

- ✎ We recommend that you use the supplied pen. Do not use sharp, pointed objects other than the pen.
- ✎ If dust or dirt from the supplied pen remains on the protective glass, clean it referring to the instructions below.

### Cleaning the exterior and display

Wipe the surface with a slightly wet, soft cloth, and then wipe with a dry cloth.

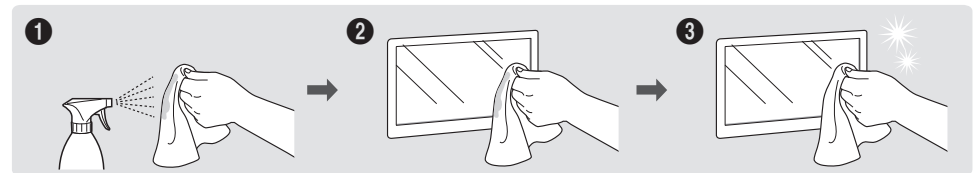





# Chapter 02

## Preparations

### Checking the Components

 Contact the vendor where you purchased the product if any components are missing.

 The appearance of the components may differ from the images shown.

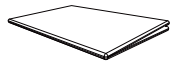

Quick Setup Guide

---



Warranty card  
(Not available in some locations)

---



Regulatory guide

---



Power cord

---



Touch Pen (2 EA)

---

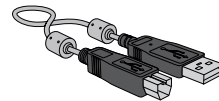





USB cable

---

## Parts

 The color and shape of parts may differ from what is shown. Specifications are subject to change without notice to improve quality.

Parts	Description
<p><b>1</b> Pen holder</p>	<p>Keep the touch pen in place.</p> <ul style="list-style-type: none"> <li>• When the product is turned off and you lift the pen from the pen holder, the screen turns on.</li> <li>• When the product is in standby mode and you lift the pen from the pen holder, the screen turns on.</li> </ul>
<p><b>2</b> NFC pad</p>	<p>Tag your smartphone to the NFC pad to connect it to the product.</p> <ul style="list-style-type: none"> <li>• Tag an NFC card to enter an email address automatically.</li> <li>• NFC tagging automatically starts the Smart View or Screen Mirroring feature of your mobile device.</li> </ul> <p> For more information about how to use NFC tagging, see page <a href="#">26</a>.</p>
<p><b>3</b> Power button</p>	<ul style="list-style-type: none"> <li>• Press the button to turn on the product.</li> <li>• Press and hold the button to turn off the product.</li> </ul> <p> When the screen is turned on, press the power button to switch to the standby mode.</p>
<p><b>4</b> Motion sensor</p>	<p>Detects user's movement.</p> <ul style="list-style-type: none"> <li>• If no motion is detected for five minutes in the standby mode, the screen turns off.</li> </ul> <p> If motion is detected after the screen is turned off due to the reason mentioned above, the product switches to standby mode.</p> <p> For ensuring normal operation of the motion sensor, do not install the product in a place exposed to direct sunlight. Do not hide the front of the motion sensor with a table or other object.</p>

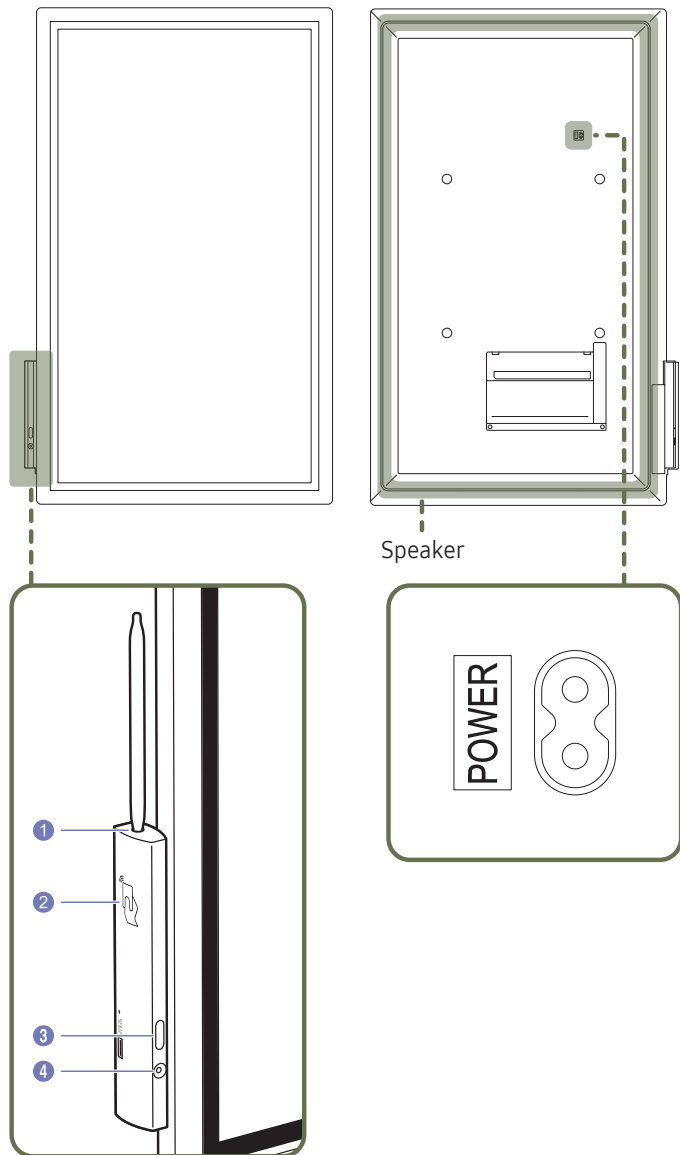



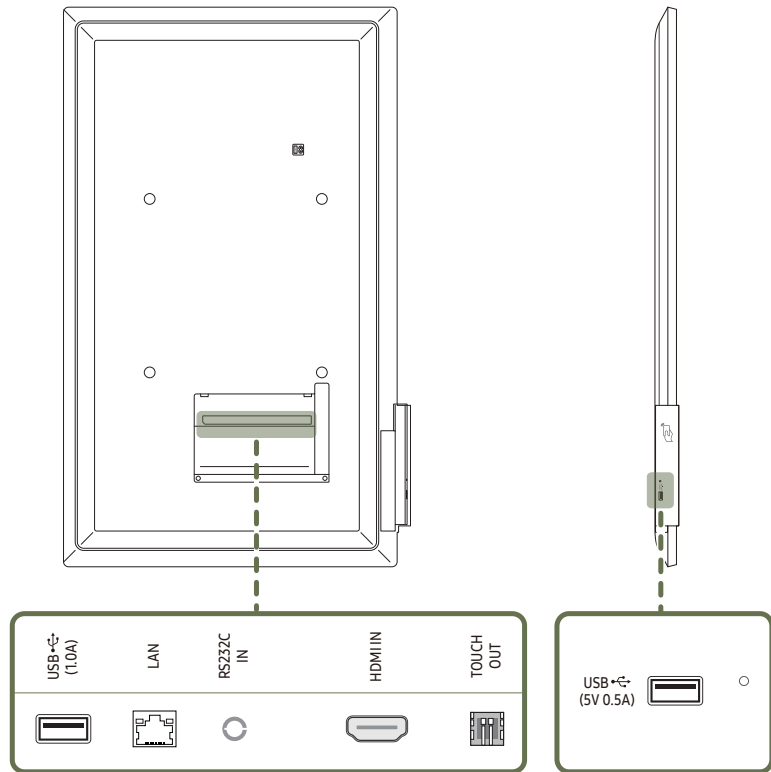

## Ports

 The color and shape of parts may differ from what is shown. Specifications are subject to change without notice to improve quality.



### Ports

### Description

USB  (1.0A)	Connect to a USB memory device.  If 1.0A is exceeded, USB operation may not be available.
LAN	Connects to a network using a LAN cable.
RS232C IN	Connects to MDC using an RS232C adapter.
HDMI IN	Connects to a source device using a HDMI cable or HDMI-DVI cable.
TOUCH OUT	Connects to a PC using a USB cable. You can operate the PC screen by touching the product screen.
USB  (5V 0.5A)	Connect to a USB memory device.  If 0.5A is exceeded, USB operation may not be available.

## Before Installing the Product (Installation Guide)

There is a product-specific stand sold separately from Samsung, and you can install it on the wall, too.

### Rotation

 Contact Samsung Customer Service Center for further details.

- To use the product in landscape orientation, turn the product anticlockwise so that the sensor part faces downward.

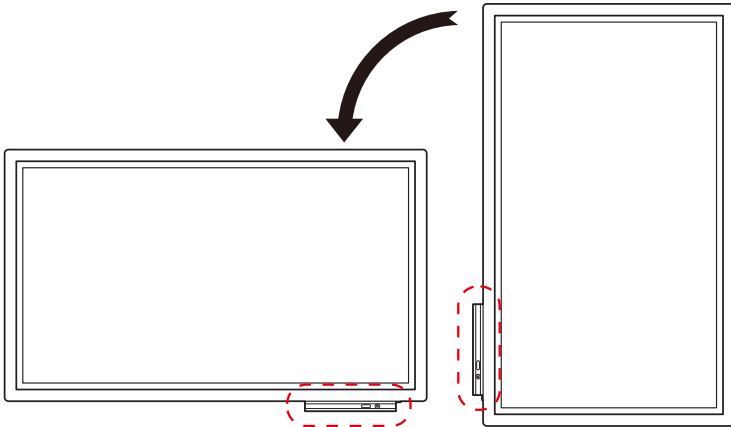

## Ventilation

### Installation on a Perpendicular Wall

A Minimum 40 mm

B Ambient temperature: Under 35°C

- When installing the product on a perpendicular wall, allow at least 40 mm of space between the product and wall surface for ventilation and ensure that the ambient A temperature is kept below 35°C.

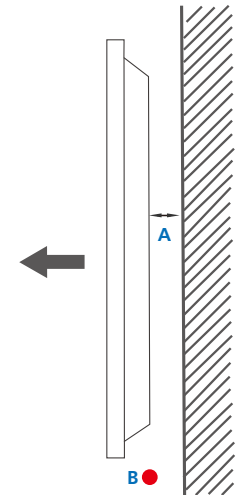

## Installation on an Indented Wall

 Contact Samsung Customer Service Center for further details.

### Plane view

A Minimum 40 mm

B Minimum 70 mm

C Minimum 50 mm

D Minimum 50 mm

E Ambient temperature: Under 35°C

 When installing the product on an indented wall, allow at least the space specified above between the product and wall for ventilation and ensure that the ambient temperature is kept below 35°C.

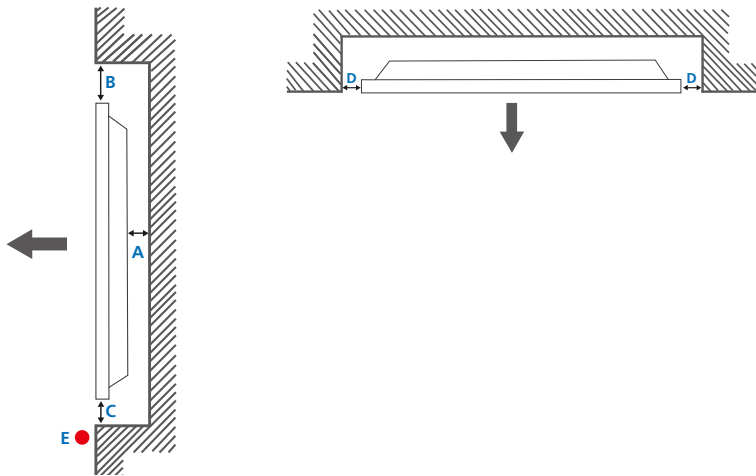

# Installing the Wall Mount

## Installing the Wall Mount

The wall mount kit allows you to mount the product on the wall.

For detailed information on installing the wall mount, see the instructions provided with the wall mount.

We recommend you contact a technician for assistance when installing the wall mount bracket.

Samsung Electronics is not responsible for any damage to the product or injury to yourself or others if you elect to install the wall mount on your own.

## Wall Mount Kit Specifications (VESA)

 Install your wall mount on a solid wall perpendicular to the floor. Before attaching the wall mount to surfaces other than plaster board, please contact your nearest dealer for additional information. If you install the product on a slanted wall, it may fall and result in severe personal injury.

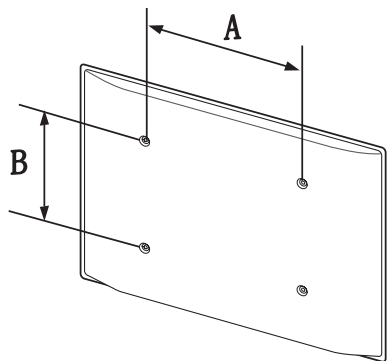

- Samsung wall mount kits contain a detailed installation manual and all parts necessary for assembly are provided.
- Do not use screws that are longer than the standard length or do not comply with the VESA standard screw specifications. Screws that are too long may cause damage to the inside of the product.
- For wall mounts that do not comply with the VESA standard screw specifications, the length of the screws may differ depending on the wall mount specifications.
- Do not fasten the screws too firmly. This may damage the product or cause the product to fall, leading to personal injury. Samsung is not liable for these kinds of accidents.
- Samsung is not liable for product damage or personal injury when a non-VESA or non-specified wall mount is used or the consumer fails to follow the product installation instructions.
- Always have two people mount the product on a wall.
- Standard dimensions for wall mount kits are shown in the table below.

VESA screw hole specs (A * B) in millimeters	Standard Screw	Quantity
--	----------------	----------

400 × 400 (15.7 × 15.7)	M8	4
-------------------------	----	---

 Do not install your Wall Mount Kit while your product is turned on. It may result in personal injury due to electric shock.

# Connecting to a network

## Network Settings (Wired)

### Connecting to a Wired Network

There are three ways to attach your product to your LAN using cable.

- You can attach your product to your LAN by connecting the LAN port on the back of your product to an external modem using a LAN cable. See the diagram below.

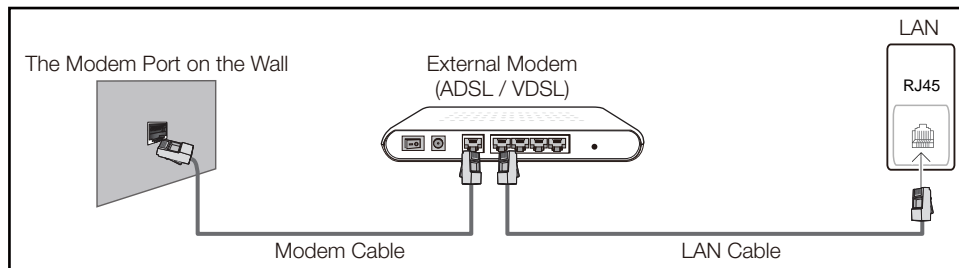

- You can attach your product to your LAN by connecting the LAN port on the back of your product to an IP Sharer which is connected to an external modem. Use LAN cable for the connection. See the diagram below.

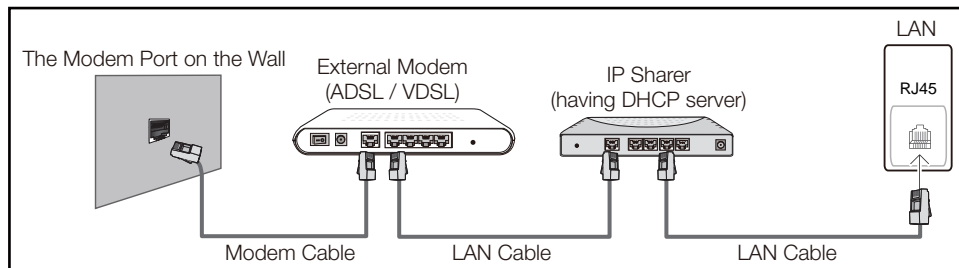

- Depending on how your network is configured, you may be able to attach your product to your LAN by connecting the LAN port on the back of your product directly to a network wall outlet using a LAN cable. See the diagram below. Note that the wall outlet is attached to a modem or router elsewhere in your house.

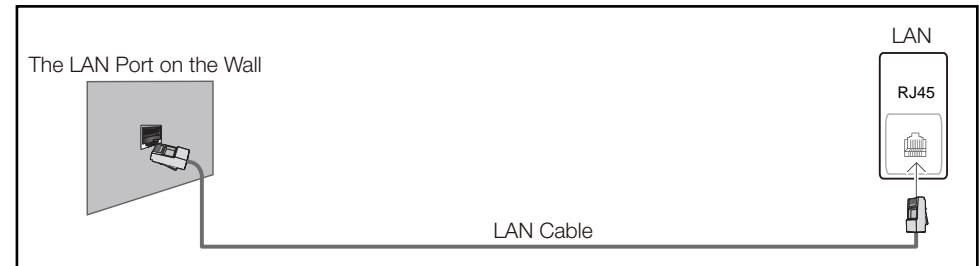

If you have a Dynamic Network, you should use an ADSL modem or router that supports the Dynamic Host Configuration Protocol (DHCP). Modems and routers that support DHCP automatically provide the IP address, subnet mask, gateway, and DNS values your product needs to access the Internet so you do not have to enter them manually. Most home networks are Dynamic Networks.

Some networks require a Static IP address. If your network requires a Static IP address, you must enter the IP address, subnet mask, gateway, and DNS values manually on your product Cable Setup Screen when you set up the network connection. To get the IP address, subnet mask, gateway, and DNS values, contact your Internet Service Provider (ISP).

If you have a Windows computer, you can also get these values through your computer.

- ✎ You can use ADSL modems that support DHCP if your network requires a Static IP address.
- ✎ ADSL modems that support DHCP also let you use Static IP addresses.

---

Set the network connection to use Internet services such as perform software upgrades.



## Automatic Open Network Settings (Wired)

Connect to the network using a LAN cable.  
Make sure a LAN cable is connected first.

### How to set up automatically

- 1 Set **Network Type** to **Wireless** from the **Open Network Settings** page.
- 2 The network test screen appears and verifies the network connection.

When the connection has been verified, the “**Success! Your device is connected to the Internet. If you have any problems using online services, please contact your Internet service provider**” message appears.

-  If the connection process fails, check the LAN port connection.
-  If the automatic process cannot find the network connection values or if you want to set the connection manually, go to the next section, network setup.

## Manual Open Network Settings (Wired)

Offices may use static IP addresses.



If this is the case, ask the network administrator for the IP address, subnet mask, gateway and DNS server address. Enter these values manually.

### Getting the Network Connection Values

To view the Network connection values on most Windows computers, follow these steps.

- 1 Right click the Network icon on the bottom right of the screen.
- 2 In the pop-up menu that appears, click Status.
- 3 On the dialog that appears, click the **Support** tab.
- 4 On the **Support** Tab, click the **Details** button. The Network connection values are displayed.

### How to set up manually

- 1 Set **Network Type** to **Wireless** from the **Open Network Settings** page.
- 2 The network test screen appears and the verification process starts. Press **Cancel**. The verification process stops.
- 3 Select **IP Settings** on network connection screen. The **IP Settings** screen appears.
- 4 Select the field at the top, press , and then set **IP Setting** to **Enter manually** Repeat the entry process for each field in the **IP Address**.  
 Setting **IP Setting** to **Enter manually** automatically changes **DNS Setting** to **Enter manually**.
- 5 When done, select **OK** at the bottom of the page, and then press . The network test screen appears and the verification process starts.
- 6 When the connection has been verified, the “**Success! Your device is connected to the Internet. If you have any problems using online services, please contact your Internet service provider**” message appears.



## Network Settings (Wireless)

### Connecting to a Wireless Network

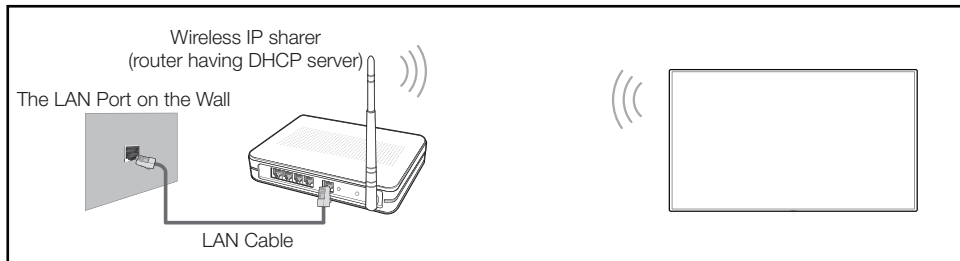



Samsung recommends using IEEE 802.11n. When you play video over a network connection, the video may not play smoothly.

- Select a channel for the wireless IP sharer that is not currently being used. If the channel set for the wireless IP sharer is currently being used by another device nearby, this will result in interference and communication failure.
- Your product supports only the following wireless network security protocols. If you select the Pure High-throughput (Greenfield) 802.11n mode and the Encryption type is set to WEP, TKIP or TKIP AES (WPS2Mixed) on your AP or wireless router, Samsung products will not support a connection in compliance with new Wi-Fi certification specifications.
- If your wireless router supports WPS (Wi-Fi Protected Setup), you can connect to the network via PBC (Push Button Configuration) or PIN (Personal Identification Number). WPS will automatically configure the SSID and WPA key in either mode.
- Connection Methods: You can setup the wireless network connection in three ways. Auto Setup (Using the Auto Network Search function), Manual Setup, **Use WPS**

### Automatic Network Setup (Wireless)

Most wireless networks have an optional security system that requires devices that access the network to transmit an encrypted security code called an Access or **Security key**. The **Security key** is based on a Pass Phrase, typically a word or a series of letters and numbers of a specified length you were asked to enter when you set up security for your wireless network. If you use this method of setting up the network connection, and have a **Security key** for your wireless network, you will have to enter the Pass Phrase during the the automatic or manual setup process.

#### How to set up automatically

- Set **Network Type** to **Wireless** from the **Open Network Settings** page.
- The **Network** function searches for available wireless networks. When done, it displays a list of the available networks.
- In the list of networks, press the ▲ or ▼ button to select a network, and then press the  button twice.
  - If the desired wireless router does not appear, select **Refresh** to search again.
  - If the router cannot be found after retrying, select the **Stop** button. The **Add Network** button appears.
- If the **Enter the password for (AP name)** screen appears, go to step 5. If you select a wireless router that does not have security, go to step 7.
- If the router has security, enter the **Enter the password for (AP name)**. (Security key or PIN).
- When done, use the right arrow button to move the cursor to **Done**, and then press . The network connection screen appears and the verification process starts.
  - A connection with the router is established, but the Internet cannot be accessed.
- When the connection has been verified, the "**Success! Your device is connected to the Internet. If you have any problems using online services, please contact your Internet service provider**" message appears.

---

## Manual Network Setup (Wireless)

Offices may use static IP addresses.







If this is the case, ask the network administrator for the IP address, subnet mask, gateway and DNS server address. Enter these values manually.

### Getting the Network Connection Values

To view the Network connection values on most Windows computers, follow these steps.

- 1 Right click the Network icon on the bottom right of the screen.
- 2 In the pop-up menu that appears, click Status.
- 3 On the dialog that appears, click the **Support** tab.
- 4 On the **Support** Tab, click the **Details** button. The Network connection values are displayed.

### How to set up manually



- 1 Set **Network Type** to **Wireless** from the **Open Network Settings** page.
- 2 The **Network** function searches for available wireless networks. When done, it displays a list of the available networks.
- 3 In the list of networks, press the ▲ or ▼ button to select a network, and then press the  button twice.
  -  If the desired wireless router does not appear, select **Refresh** to search again.
  -  If the router cannot be found after retrying, select the **Stop** button. The **Add Network** button appears.
- 4 If the **Enter the password for (AP name)**. screen appears, go to step 5. If you select a wireless router that does not have security, go to step 7.
- 5 If the router has security, enter the **Enter the password for (AP name)**. (Security key or PIN).
- 6 When done, use the right arrow button to move the cursor to **Done**, and then press . The network connection screen appears and the verification process starts.
- 7 Select **Cancel** while network connections are being attempted. This will stop the connection.
- 8 Select **IP Settings** on network connection screen. The **IP Settings** screen appears.
- 9 Select the field at the top, press , and then set **IP Setting** to **Enter manually**. Repeat the entry process for each field in the **IP Address**.
  -  Setting **IP Setting** to **Enter manually** automatically changes **DNS Setting** to **Enter manually**.
- 10 When done, select **OK** at the bottom of the page, and then press . The network test screen appears and the verification process starts.
- 11 When the connection has been verified, the “**Success! Your device is connected to the Internet. If you have any problems using online services, please contact your Internet service provider**” message appears.

---

## Use WPS

### How to set up using Use WPS



If your router has a **Use WPS** button, follow these steps.

- 1 Set **Network Type** to **Wireless** from the **Open Network Settings** page.
- 2 Select **Use WPS**, press , and then press  again.
- 3 Press the WPS or PBC button on your wireless router within the next two minutes. Your product automatically acquires all the network setting values it needs and connects to your network.
- 4 The network connection screen appears, and network setup is done.

# Chapter 03

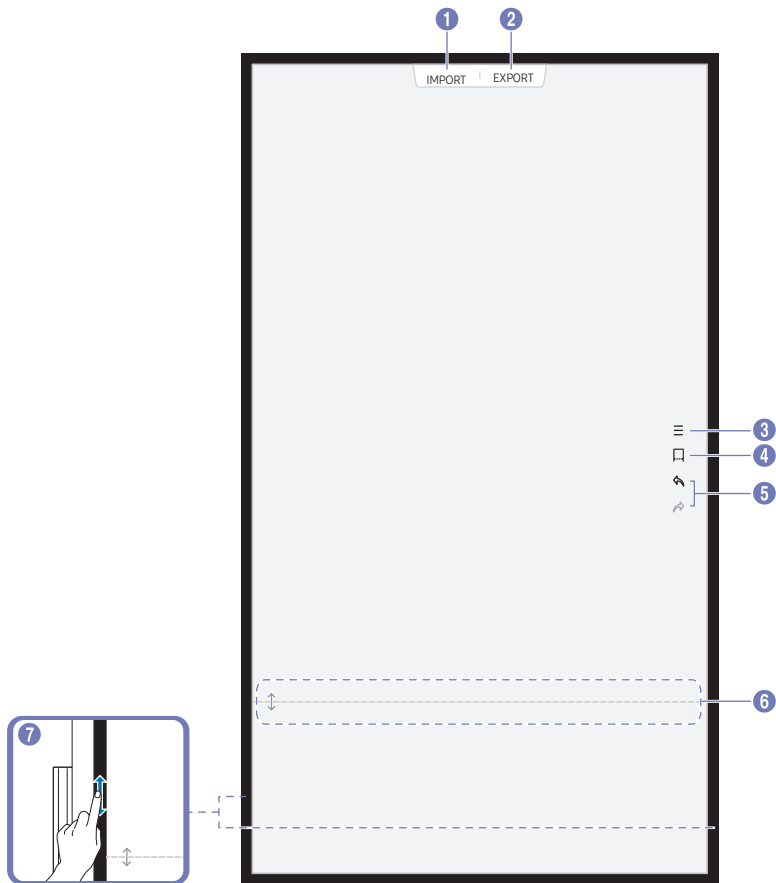
## Screen Elements



Buttons	Description
<b>1</b> <b>IMPORT</b>	Display the screen of a connected device, or import photos and other data from it.
<b>2</b> <b>EXPORT</b>	Share your creations in various ways.
<b>3</b> 	Manage and change the rolls and settings.
<b>4</b> 	Move or edit the page.
<b>5</b> 	Undo or redo the last action.
<b>6</b> Handler Area	Move the page up/down.
<b>7</b> Bezel Scroll	Scroll through the page.

# Chapter 04

## Create

### Drawing / Eraser

You can freely use the supplied pen to write anything you want.

- Thin Tip (A): Pen Type
- Thick Tip (B): Highlighter Type

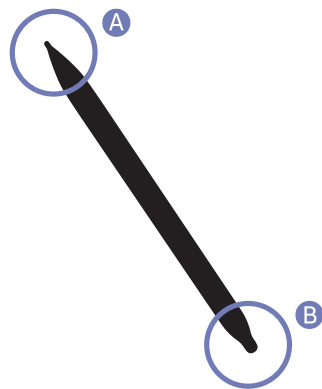

### Changing the pen thickness

You can change the pen thickness.

 Change the pen thickness at  → Pen → Pen & Highlighter Thickness.

### Changing the pen color

You can change the pen color by touching and holding the screen with the pen.

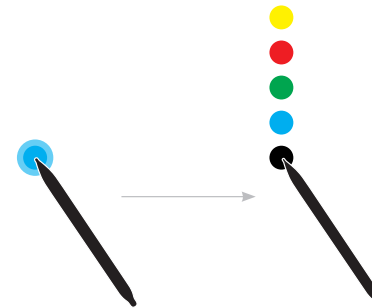

 Change the pen color at  → Pen → Pen Color or Highlighter Color.

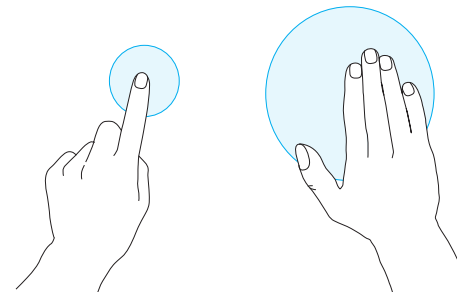

### Eraser

You can use your finger or palm to erase your writing.

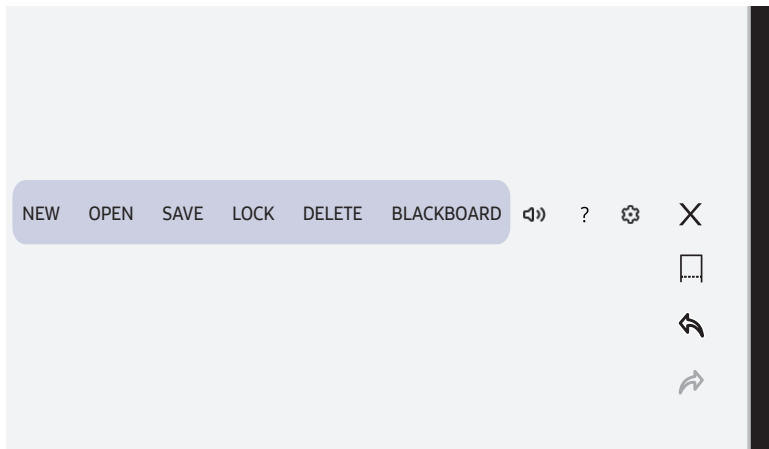
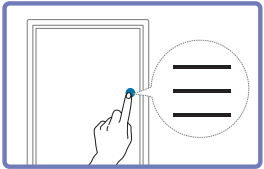

# Managing Rolls



Buttons	Description
<b>NEW</b>	Create a new roll.
<b>OPEN</b>	<b>OPEN</b> , <b>DELETE</b> , or <b>EXPORT</b> a saved roll.
<b>SAVE</b>	Save the current roll.
<b>LOCK</b>	Press a four-digit password to lock the current roll.  When locked, the current roll is automatically saved and a new roll is opened.
<b>DELETE</b>	Delete the current roll.
<b>BLACKBOARD / WHITEBOARD</b>	Change the writing mode.  The roll you are editing is automatically saved and a new roll is opened.

## OPEN

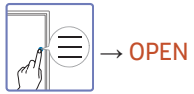

Select the desired roll.

To open a locked roll (🔒), press its password.

The rolls are sorted by recent date.

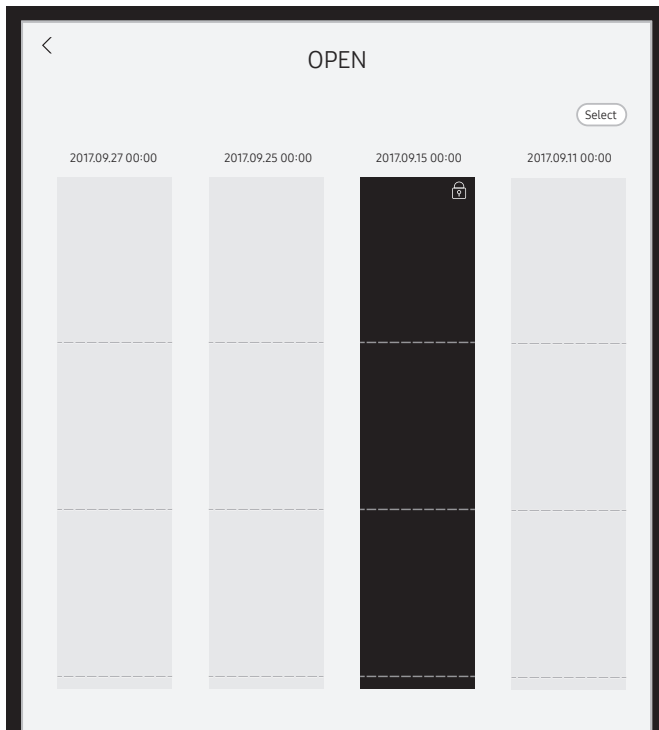

## Select

☰ → OPEN → Select

You can select multiple rolls to export or delete.

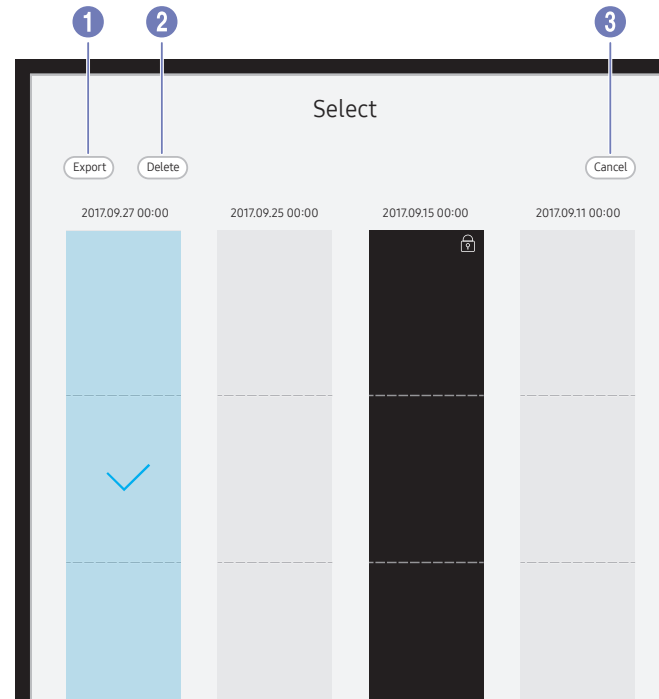

### Parts

### Description

- |   |               |  |
|---|---------------|--|
| 1 | <b>Export</b> | Share the selected rolls any way you like.<br><b>Email / USB</b> |
| 2 | <b>Delete</b> | Delete the selected rolls.                                       |
| 3 | <b>Cancel</b> | Deselect the roll.   |



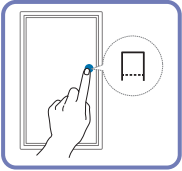

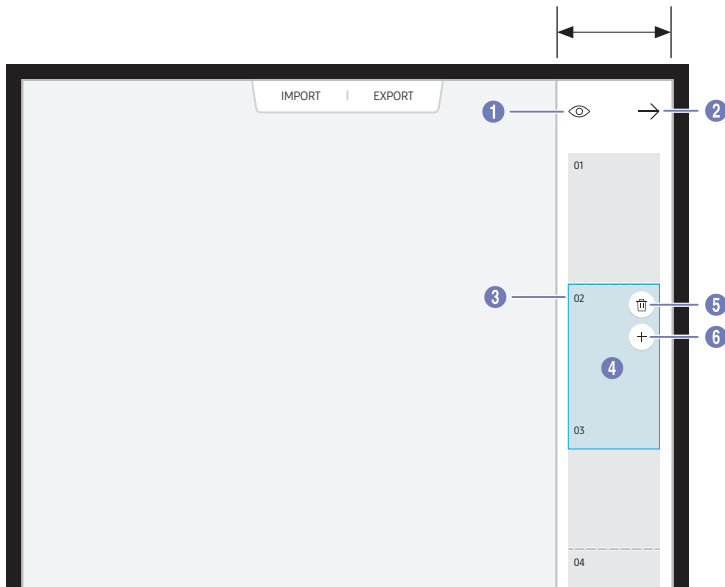

# Page Viewer



Page viewer area



You can edit the page by zooming in on the created roll.

Parts	Description
1 	Preview the roll.  The preview mode does not support the write/erase function.
2 	Close the page viewer.
3 <b>Page number</b>	Displays the page number.
4 <b>Focus</b>	Displays the page you are currently viewing. <ul style="list-style-type: none"><li>• When you select a page, the focus is moved to it.</li><li>• Drag and drop the focus to move it to other page.</li><li>• Press and hold the focused page to change its page order.</li></ul>
5 	Delete the focused page.
6 	Add a new page to the focused position.  You can create up to 20 pages per roll.



# Chapter 05





## IMPORT

You can display the screen of a connected device, or import photos and other data from it.

Touch **IMPORT** at the top of the screen to select the desired device.

 You can capture the screens you want from the imported content.



Icons	Description
	Displays your phone screen imported using screen mirroring.
	Displays your laptop screen imported using HDMI connection or screen mirroring.
	Displays images and dedicated files (.iwb) imported from a connected USB device.
	Displays images and dedicated files (.iwb) imported from a connected network drive.

 Dedicated files (.iwb) are available on this product only.

---

## Connecting to a Mobile Device

### Connecting using screen mirroring



- 1 Drag down the top bar on the mobile device screen to start **Smart View** or **Screen Mirroring**.
- 2 Select this product from the list of devices displayed on the screen.

 The initial device name is [Flip] Samsung WMH Series.

### Connecting using NFC tagging

 Only some models of Samsung mobile devices are supported.

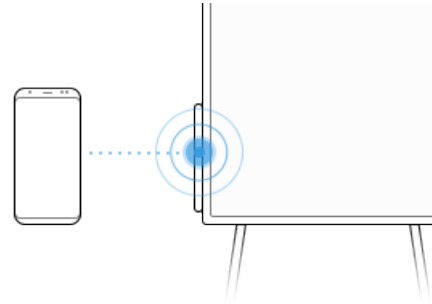

- 1 Turn on the NFC feature on a supported mobile device.
- 2 Tag the mobile device to the NFC pad at the side of the product.

 You can control the mobile device from the product screen.

## Connecting to a Laptop

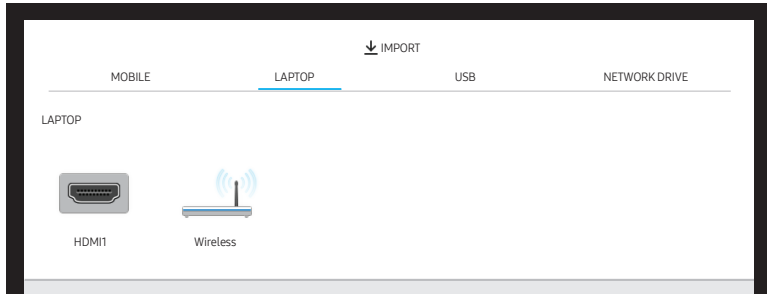

### Connecting using a cable

#### Connecting using an HDMI cable

- 1 Connect the product to the laptop using an HDMI cable.



- 2 Select **IMPORT** → **LAPTOP** → **HDMI1** from the top of the screen.

#### Connecting using a USB cable

To control the laptop from the product screen, connect the supplied USB cable to the **TOUCH OUT** port on the product.

- ✎ This function is supported only when the laptop screen is in both landscape orientation and the full screen mode.



## Connecting using a screen mirroring

- ✎ This function is only available for laptops that support screen mirroring.

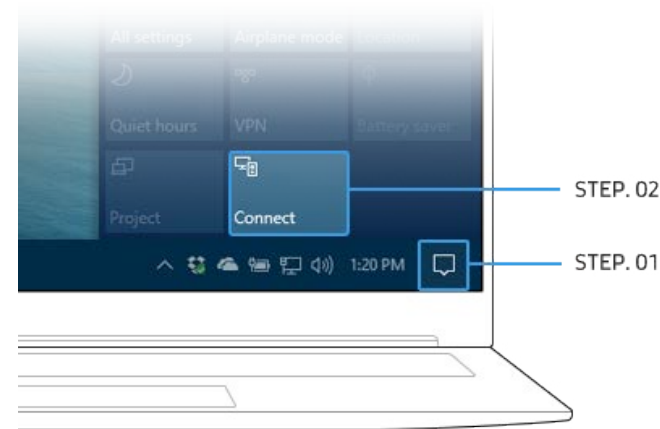

- 1 Select 'Action Center' or 'Devices' in the taskbar notification area of the laptop.
- 2 Click 'Connect' or 'Project' and select a [Flip] Samsung WMH Series device to complete the connection.

- ✎ The connection procedure may vary depending on the laptop.
- ✎ After connecting to a laptop using screen mirroring, you can control the laptop screen from the product screen.

## Importing from a USB Device

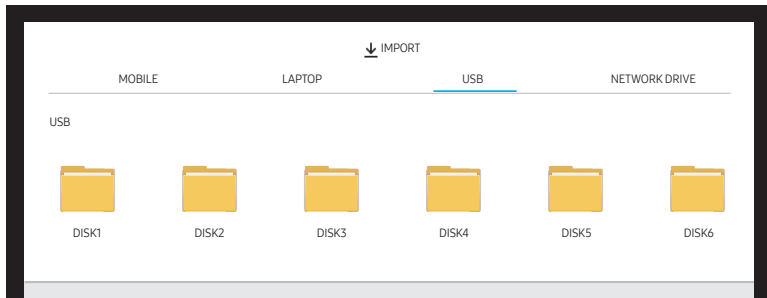

Connect an external HDD or a USB storage device.

 You can import only images and dedicated files (.iwb).

## Importing from a Network Drive

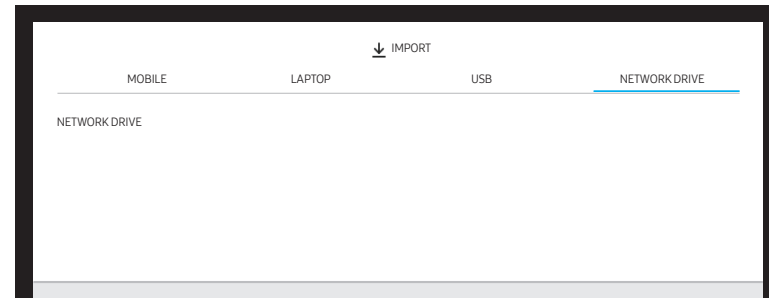

You can register a network drive while the network is connected.

 You can import only images and dedicated files (.iwb).









 You can register a network drive account at  → **Connect** → **Network Drive** → **Add Account**.

To register a network drive account, you must enter the **Address**, **Username**, and **Password**.

 For information about how to connect to a network, see page [14](#).

# PIP screen







Parts	Description
1 Menu bar	Drag the PIP screen to move it to the desired position.
2 Device name	Displays the name of the connected device.
3 	Capture the PIP screen.
4 	Rotate the PIP screen.
5 	Switch to the full screen mode.  To return to the previous screen from the full screen mode, press the Power button.  Only some models of the Samsung mobile devices support the full screen mode (portrait).  The full screen mode of the laptop is only supported in the landscape orientation of the product.
6 	Close the PIP screen.
7 	Adjust the size of the PIP screen.

# Chapter 06

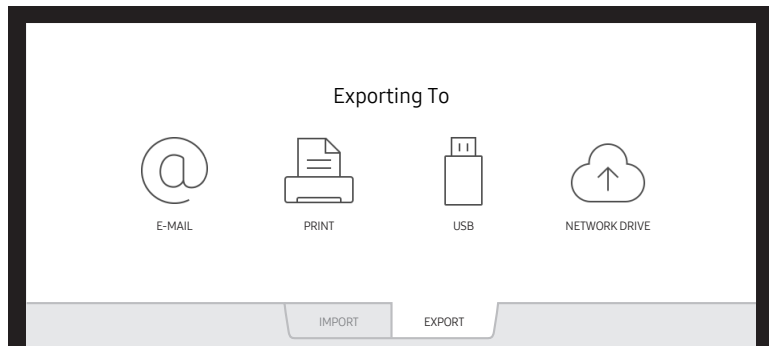
## EXPORT

You can export your created rolls in various ways.



Icons	Description
	Send your created rolls via email.
	Print your created rolls.
	Export your created rolls to a connected USB device.
	Export your created rolls to a registered network drive.

# E-MAIL

To send your created rolls via email, first register your email account.





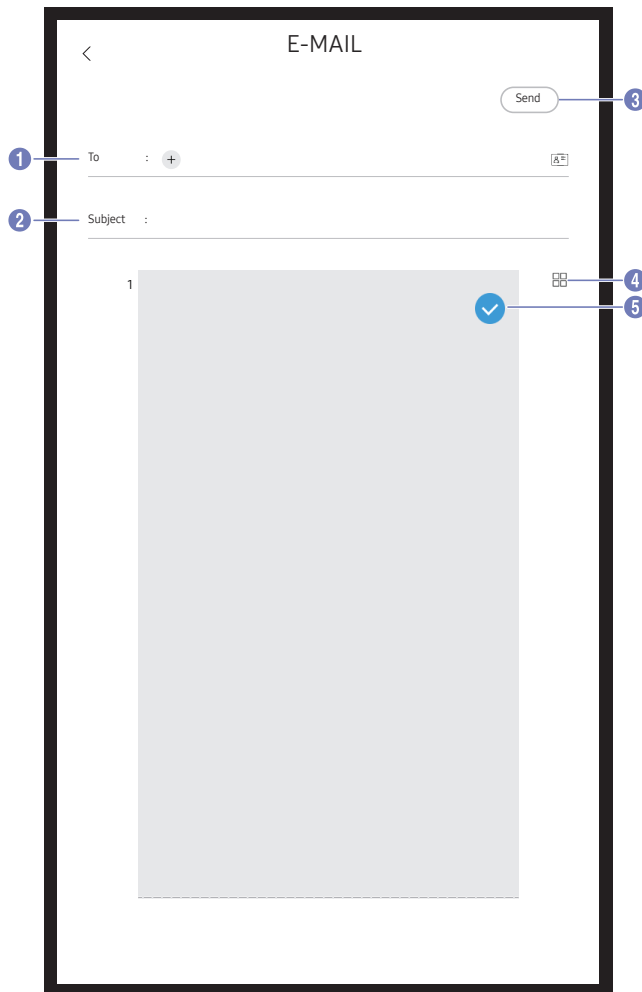



 You can register your email account at  → **Connect** → **E-mail**.

To register your email account, you must enter your **SMTP Server Name**, **SMTP Port Number**, **Account**, and **Password**.



## Parts

## Description

- |  |  |
|--|--|
| <b>1</b> To  | Enter the recipient's email address. <ul style="list-style-type: none"><li>• Press  to type text on the virtual keyboard that appears.</li><li>• Press  on the virtual keyboard to enter text by handwriting.</li><li>• When you tag an NFC card that has an email address entered, it is automatically entered.</li></ul> <p>  : NFC Describes where to tag the NFC card.</p> <p> Using the NFC Writing App, register an email address with the NDEF Standard &lt;Text&gt; Record Type to an NFC Forum Type 2 Card sold on the market.</p> |
| <b>2</b> Subject   | The email subject is automatically set to the device name and the current date. <p> The email subject cannot be changed.</p>  |
| <b>3</b> Send  | Send the email.  |
| <b>4</b>  /  | Change the page view mode for the roll to send.  |
| <b>5</b>    | Select the pages to send.  |

# PRINT

Be sure to set up the print server while the network is connected.

 You can set up the print server at  → **Connect** → **Print Server Settings**.

 For information about how to connect to a network, see page [14](#).

## NetPrinting Server Program Installation

To use the **PRINT** function, you must install the **NetPrinting Server** program on the PC you want to connect to.

 When the program installation is completed, the PC is automatically connected. The installation takes about 8 minutes.

 Follow the onscreen instructions to install **NetPrinting Server**. The **NetPrinting Server** program is available on its website (<https://btsp.samsungsbn.com/>).

### Installation requirements

The PC must be connected to the Internet while the installation is proceeding.

 The PC and printer to be connected must be connected to the same network as the product.

- Supported operating systems:  
Windows 7(32/64 bit), Windows 8(32/64 bit), Windows 10(32/64 bit)

 To install the **NetPrinting Server** program, update your Windows update to the latest version.

- Required programs  
Net Framework 4.6.1

## Setting up the printer

After the **NetPrinting Server** program is installed, make the following settings on the product onscreen menu.

### Setting up automatically

- 1 Select  → **Connect** menu.

 The default PIN number is 0000.

- 2 Select **Print Server Settings** → **Connect Server** → **Auto**.

### Setting up manually

- 1 Select  → **Connect** menu.

 The default PIN number is 0000.



- 2 Select **Print Server Settings** → **Connect Server** → **Manual**, and then enter the **Server IP** address of the PC where **NetPrinting Server** is installed.

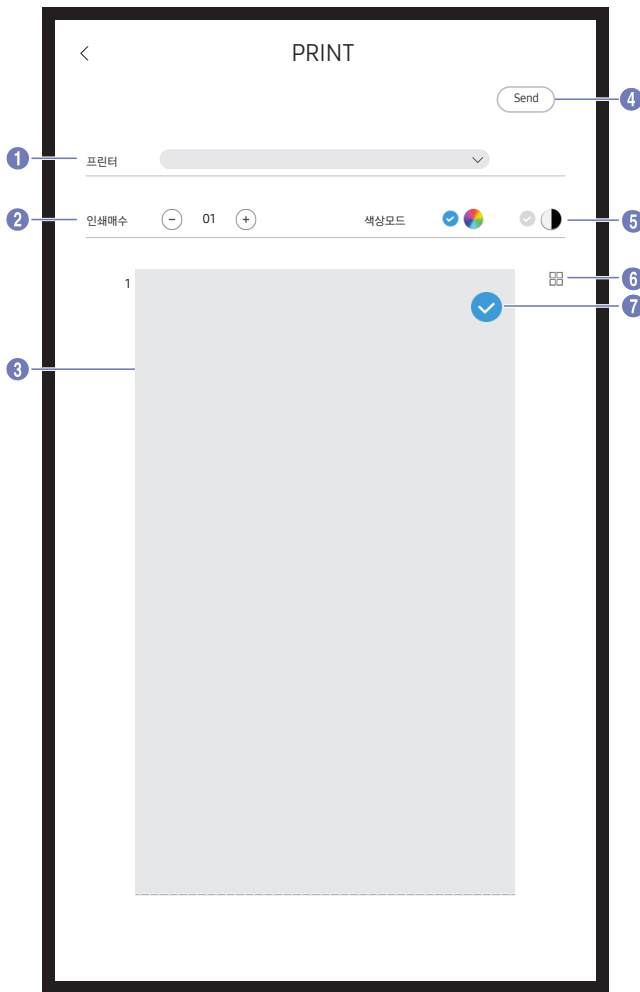



## Parts

## Description

Parts	Description
① 프린터	Displays a list of connected printers. Select a printer to print the roll with.
② 인쇄매수	Set the number of prints.
③ Print preview	Preview the roll to print.
④ Send	Start the printing.
⑤ 색상모드	Select the color to print the roll with.
⑥  / 	Change the page view mode for the roll.
⑦ 	Select the pages to print.

## Exporting to a USB Device

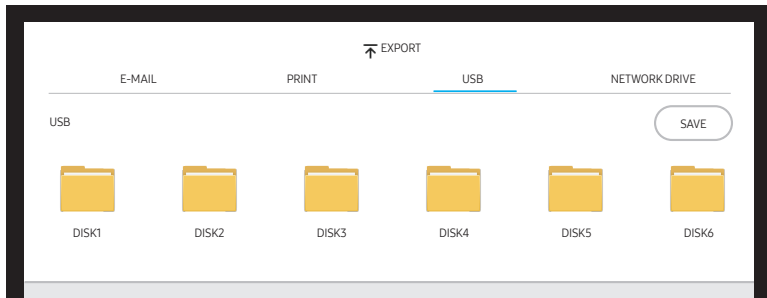

Connect an external HDD or a USB storage device.

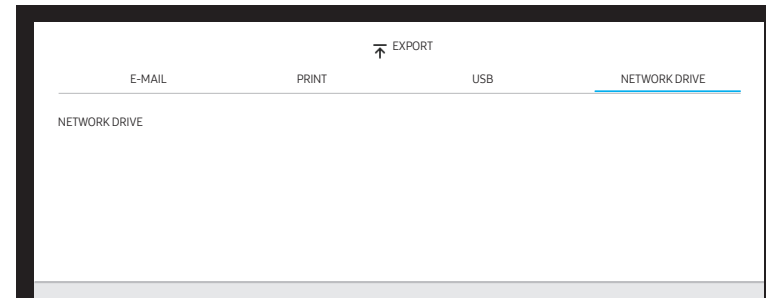

 You can save only dedicated files (.iwb)

## Exporting from a Network Drive



You can register a network drive while the network is connected.

 You can import only images and dedicated files (.iwb).



 You can register a network drive account at  → **Connect** → **Network Drive** → **Add Account**.

To register a network drive account, you must enter the **Address**, **Username**, and **Password**.

 For information about how to connect to a network, see page [14](#).





# Connect

2nd	3rd	Description
Network		Configure your device's network.
	Network Status	View your current network and internet status.
	Open Network Settings	Configure network settings to connect to an available network.
	Proxy Server	Set up your proxy server connection and related functions.
E-mail		Set up an email account for sending emails.  To register your email account, you must enter your <b>SMTP Server Name</b> , <b>SMTP Port Number</b> , <b>Account</b> , and <b>Password</b> .
Print Server Settings		To use the <b>PRINT</b> function, you must install the NetPrinting Server program on the PC you want to connect to. Follow the onscreen instructions to install NetPrinting Server. The NetPrinting Server program is available on its website ( <a href="https://btsp.samsungsbn.com/">https://btsp.samsungsbn.com/</a> ). <ul style="list-style-type: none"><li>• <b>Connect Server</b> <b>Auto:</b> When the <b>NetPrinting Server</b> program installation is completed, the PC is automatically connected. <b>Manual:</b> Enter the <b>Server IP</b> address of the PC where <b>NetPrinting Server</b> is installed.</li></ul>
Network Drive		Add or edit network drive accounts. You can only add network drives by using Samba.
	Add Account	Add new network drive accounts. Only Samba can be added to the network drive.  To register a network drive account, you must enter the <b>Address</b> , <b>Username</b> , and <b>Password</b> .
	Edit Account	Edit network drive accounts.
Device Connect Manager		Allow devices, like smartphones and tablets, on your network to share content with your signage.
	Access Notification	Display a notification when a device, such as a smartphone or tablet, is connected. If you use a Wi-Fi network that requires a password, turn off this option to automatically connect with devices without viewing notifications.
	Device List	View and manage connected devices.

---

# System

2nd	3rd	Description
Language		Change your <b>Language</b> settings.
Time		Set current date and time.
	Clock Set	Set the date.
	DST	Adjust clock for Daylight Saving Time. To set the daylight saving time, be sure to set this item to <b>On</b> .
Smart Security		Security provided to protect your display device and connected storage devices against viruses includes.
	Scan	Inspect your display device and connected storage devices to check for viruses.
	Isolated List	Check the list of items that have been isolated they contain viruses.
Change PIN		Changes your 4-digit Personal Identification Number (PIN).  The default PIN number is 0000.
Device Name		Enter Device Name. You can find this name on the device being used over the network.
Advanced Settings		Set the menu <b>Advanced Settings</b> . Enter your 4 digit PIN number. The default PIN number is "0-0-0-0".  If you want to change the PIN number, use the <b>Change PIN</b> function.
	USB Lock	Set up a <b>USB Lock</b> . After setting up, the device will be restarted to apply the settings.
	Network Lock	Set up a <b>Network Lock</b> . After setting up, the device will be restarted to apply the settings.
	Auto Save & Auto Power Off	Automatically save all data. To set <b>Auto Power Off</b> , <b>Auto Save</b> must be restarted to apply the settings.
	Motion Sensor	Set the motion sensor duration to automatically shut down this device when no motion is detected.
	Erase all files	Delete all data from the device, including lock data.
	Start Setup	It initializes all items in the total menu.

---

## Picture

2nd	3rd	Description
Backlight		Adjust backlight brightness to suit your preference. 100 is the brightest setting.
Color Temperature		It sets color temperature. The value and temperature increase simultaneously, so the ratio of blue color rises.
White Balance	R-Offset / G-Offset / B-Offset / R-Gain / G-Gain / B-Gain / Reset	Adjust the color temperature of the picture so that white objects appear brighter.
Reset Picture		Restore all picture settings to the factory default.

---

# Support

2nd	3rd	Description
<a href="#">Software Update</a>		Update the software installed on your product.
	<a href="#">Update Now</a>	Update software by downloading update files. <ul style="list-style-type: none"><li>• <b>Current version:</b> This is the software version already installed in the product.</li></ul>
	<a href="#">Auto Update</a>	Automatically start software updates once your device is powered off. <ul style="list-style-type: none"><li>• <b>Current version:</b> This is the software version already installed in the product.</li></ul>
<a href="#">Contact Samsung</a>		View this information when your product does not work properly or when you want to upgrade the software. You can find information regarding our call centers and how to download products and software.  <a href="#">Contact Samsung</a> and find the product <a href="#">Model Code</a> and <a href="#">Software Version</a> .
<a href="#">Reset All</a>		It initializex all items in the total menu.

# Chapter 08

## Troubleshooting Guide

### Check the followings.

---

 Before calling Samsung Customer Service Center, test your product as follows. If the problem persists, contact Samsung Customer Service Center.

---

 If the product is not turned on or off when you operate the buttons or motion sensor of the product, you can turn it on or off with the Samsung remote control or Samsung remote control application.

#### PIP screen (HDMI) issue

---

**Blank spaces are found on all four sides of the screen when an HDMI cable is connected to the product and PC.**

The blank spaces found on the screen have nothing to do with the product.

---

Blank spaces on the screen are caused by the PC or graphics card. To resolve the problem, adjust the screen size in the HDMI settings for the graphics card.

---

If the graphics card settings menu does not have an option to adjust the screen size, update the graphics card driver to the latest version.

(Please contact the graphics card or computer manufacturer for further details about how to adjust the screen settings.)

---

**The images on the screen look distorted.**

Check the cable connection to the product.

---

**The screen is not clear. The screen is blurry.**

Set the resolution and frequency to the recommended level.

---

**The screen appears unstable and shaky.**

Check that the resolution and frequency of the PC and graphics card are set within a range compatible with the product. Then, change the screen settings if required by referring to the Additional Information on the product menu and the Standard Signal Mode Table.

---

**There are shadows or ghost images left on the screen.**

---



---

## PIP screen (HDMI) issue

---

White does not really look white.

Go to **Picture** and adjust the **White Balance** settings.

The product will turn off automatically.

Make sure the power cable is connected properly to the product and power outlet.

The screen display does not look normal.

Encoded video content may cause the display to appear corrupted in scenes featuring fast moving objects such as in a sports event or action video.

Low signal level or low picture quality may cause the display to appear corrupted. This does not mean the product is defective.

A cell phone within a distance of one-meter radius may cause static on analog and digital products.

The brightness and color do not look normal.

From the menu, select **Support** → **Reset All** to try resetting the screen.

The display looks unstable and then freezes.

The screen may freeze when a resolution other than the recommended resolution is used or if the signal is not stable. To resolve the issue, change the PC resolution to the recommended resolution.

The screen cannot be displayed in full screen.

If the PIP window is set to the full screen mode when the product is in portrait orientation, a black bar appears at both the top and bottom.

Change the product to landscape orientation, and then try switching the PIP window to the full screen mode.

---

---

## Sound issue

---

There is no sound.

Check the volume.

---

The volume is too low.

Adjust the volume.

---

If the volume is still low even when it is adjusted to the maximum, adjust the volume of the connected PC or mobile device again.

---

Video is available but there is no sound.

If an HDMI cable is connected, check the audio output settings on the PC.

---

If a source device is used

- Check the audio output settings for the source device.  
(For example, if an HDMI cable is connected to the **product**, the audio setting for the cable box may need to be changed to HDMI.)

---

Reconnect the power cable to the device and then reboot the device.

---

There is static coming from the speakers.

Low signal level can cause corrupted sound.

---

There is audible sound when the volume is muted.

Audio settings for main speakers are separate from the internal speakers on the product.  
Changing or muting the volume on the product does not affect an external amplifier(decoder).

---

---

## Touch function issues

The touch function does not work.	Make sure the screen or your finger is not wet.
	Make sure you are not wearing a glove and your finger is not dirty.
The icons can be touched but the drawings cannot.	Use the supplied product-specific pen as much as possible.
Drawing and eraser do not work when PIP connection is used.	In the PIP mode, the drawing function is not supported within the PIP area. In the PIP mode, drawings in a PC application such as Paintare made by that PC application.
Touching does not work when HDMI connection is used.	Make sure that the screen is in the full screen mode (Landscape).
	Check whether the <b>TOUCH OUT</b> port of the product is connected to the PC using a USB cable.
I use two pens, but they do not work well.	Make sure that there is enough space between the two pens at multi-touching.
Touches break, reaction speed gets slow, and so on.	Make sure that there are no foreign substances on the screen surface.
	Check whether the screen is broken.
	Make sure that the product is not exposed to direct sunlight.

---

---

## Other issue

The product smells like plastic.	The plastic smell is normal and disappears over time.
Small particles are found on the edges of the product.	The particles are part of the product design. The product is not defective.
When I try to change the PC resolution, a message " <b>The defined resolution is not currently supported.</b> " appears.	The message "The defined resolution is not currently supported." appears if the input source resolution exceeds the maximum resolution of the display. To resolve the issue, change the PC resolution to a resolution supported on the product.
There is no sound from the speakers in HDMI mode when a DVI-HDMI cable is connected.	DVI cables do not transmit sound data.
<b>HDMI Black Level</b> is not functioning properly on an HDMI device with YCbCr output.	This function is available only when a source device, such as a DVD player and STB, is connected to the product via an HDMI (RGB signal) cable.
There is no sound in HDMI mode.	Displayed picture colors may not look normal. Video or sound may not be available. This can occur if a source device that only supports an older version of the HDMI standard is connected to the product.
The product gets slow or is not turned off.	If the product gets slow down or is not turned off, press and hold the Power button for 10 seconds. The product is turned off and on again.

# Chapter 09

## Specifications

### General

<b>Model Name</b>		<b>WM55H</b>
<b>Panel</b>	<b>Size</b>	55 CLASS (54.6 inches / 138.7 cm)
	<b>Display area</b>	TBD mm (H) x TBD mm (V)
<b>Synchronization</b>	<b>Horizontal Frequency</b>	30 - 81kHz, 30 - 90kHz (HDMI)
	<b>Vertical Frequency</b>	48 - 75Hz, 24 - 75Hz (HDMI)
<b>Resolution</b>	<b>Optimum resolution</b>	1920 x 1080 @ 60Hz, 3840 x 2160 @ 60Hz
	<b>Maximum resolution</b>	1920 x 1080 @ 60Hz, 3840 x 2160 @ 60Hz
<b>Power Supply</b>		AC 100 to 240 VAC (+/- 10%), 60 / 50 Hz ± 3 Hz Refer to the label at the back of the product as the standard voltage can vary in different countries.
<b>Environmental considerations</b>	<b>Operating</b>	Temperature : 32 °F – 104 °F (0 °C – 40 °C) * For installing the housing, keep the internal temperature at 40 °C or below. Humidity : 10% – 80%, non-condensing
	<b>Storage</b>	Temperature : -4 °F – 113 °F (-20 °C – 45 °C) Humidity : 5% – 95%, non-condensing

#### Horizontal Frequency

The time required to scan a single line from the left to the right side of the screen is called a horizontal cycle. The reciprocal number of a horizontal cycle is called horizontal frequency. Horizontal frequency is measured in kHz.

#### Vertical Frequency

The product displays a single image multiple times per second (like a fluorescent light) to display what the viewer sees. The rate of a single image being displayed repeatedly per second is called vertical frequency or refresh rate. Vertical frequency is measured in Hz.

---

 Plug-and-Play

This monitor can be installed and used with any Plug-and-Play compatible systems. Two-way data exchange between the monitor and PC system optimizes the monitor settings. Monitor installation takes place automatically. However, you can customize the installation settings if desired.

 Due to the nature of the manufacturing of this product, approximately 1 pixel per million (1ppm) may appear brighter or darker on the panel. This does not affect product performance.

 This is a class A product. In a domestic environment this product may cause radio interference in which case the user may be required to take adequate measures.

 For detailed device specifications, visit the Samsung Electronics website.

(USA only)

Dispose unwanted electronics through an approved recycler.

To find the nearest recycling location, go to our website: [www.samsung.com/recyclingdirect](http://www.samsung.com/recyclingdirect) or call, (877) 278 - 0799

## Preset Timing Modes

 This product can be set to only one resolution for each screen size to obtain the optimum picture quality due to the nature of the panel. Using a resolution other than the specified resolution may degrade the picture quality. To avoid this, it is recommended that you select the optimum resolution specified for your product.

The screen will automatically be adjusted if a signal that belongs to the following standard signal modes is transmitted from your PC. If the signal transmitted from the PC does not belong to the standard signal modes, the screen may be blank with the power LED on. In such a case, change the settings according to the following table by referring to the graphics card user manual.

Resolution	Horizontal Frequency (kHz)	Vertical Frequency (Hz)	Pixel Clock (MHz)	Sync Polarity (H/V)
IBM, 640 x 480	31.469	59.940	25.175	-/-
IBM, 720 x 400	31.469	70.087	28.322	-/+
MAC, 640 x 480	35.000	66.667	30.240	-/-
MAC, 832 x 624	49.726	74.551	57.284	-/-
MAC, 1152 x 870	68.681	75.062	100.000	-/-
VESA, 640 x 480	31.469	59.940	25.175	-/-
VESA, 640 x 480	37.861	72.809	31.500	-/-
VESA, 640 x 480	37.500	75.000	31.500	-/-
VESA, 800 x 600	35.156	56.250	36.000	+/+
VESA, 800 x 600	37.879	60.317	40.000	+/+
VESA, 800 x 600	48.077	72.188	50.000	+/+
VESA, 800 x 600	46.875	75.000	49.500	+/+
VESA, 1024 x 768	48.363	60.004	65.000	-/-

Resolution	Horizontal Frequency (kHz)	Vertical Frequency (Hz)	Pixel Clock (MHz)	Sync Polarity (H/V)
VESA, 1024 x 768	56.476	70.069	75.000	-/-
VESA, 1024 x 768	60.023	75.029	78.750	+/+
VESA, 1152 x 864	67.500	75.000	108.000	+/+
VESA, 1280 x 720	45.000	60.000	74.250	+/+
VESA, 1280 x 800	49.702	59.810	83.500	-/+
VESA, 1280 x 1024	63.981	60.020	108.000	+/+
VESA, 1280 x 1024	79.976	75.025	135.000	+/+
VESA, 1366 x 768	47.712	59.790	85.500	+/+
VESA, 1440 x 900	55.935	59.887	106.500	-/+
VESA, 1600 x 900	60.000	60.000	108.000	+/+
VESA, 1680 x 1050	65.290	59.954	146.250	-/+
VESA, 1920 x 1080	67.500	60.000	148.500	+/+
CEA, 3840 x 2160	67.500	30.000	297.000	-/-



# Chapter 10

## Appendix

### Responsibility for the Pay Service (Cost to Customers)

 When the service is requested, in spite of in warranty, we may charge you for a visit from a service technician in the following cases.

#### Not a product defect

Cleaning of the product, Adjustment, Explanation, Re-installation and etc.

- If a service technician gives instructions on how to use product or simply adjusts options without disassembling product.
- If a defect is caused by external environmental factors (Internet, Antenna, Wired Signal, etc.)
- If a product is reinstalled or devices are connected additionally after installing the purchased product for the first time.
- If a product is reinstalled to move to a different spot or to move to a different house.
- If customer requests instructions on how to use because of another company's product.
- If customer requests instructions on how to use the network or another company's program.
- If customer requests software installation and setup for the product.
- If a service technician removes/cleans dusts or foreign materials inside of the product.
- If customer requests an installation additionally after purchasing a product through home-shopping or online.

### A Product damage caused by customer's fault

Product damage caused by customer's mishandling or wrong repair

If a product damage is caused by;

- External impact or drop.
- Use of supplies or separately sold product unspecified by Samsung.
- Repair from a person besides an engineer of outsourcing service company or partner of Samsung Electronics Co., Ltd.
- Remodeling or repairing the product by customer.
- Using it with incorrect voltage or non-authorized electrical connections.
- Not following the "cautions" in User Manual.

#### Others

- If product fails by natural disaster. (lightning, fire, earthquake, flood damage, etc)
  - If consumable components are all used up. (Battery, Toner, Fluorescent lights, Head, Vibrator, Lamp, Filter, Ribbon, etc.)
-  If customer requests a service in case the product has no defect, service fee may be charged. So please read User Manual first.

# Optimum Picture Quality and Afterimage Burn-in Prevention

## Optimum Picture Quality

- Due to the nature of the manufacturing of this product, approximately 1 pixel per million (1ppm) may be brighter or darker on the panel. This does not affect product performance.
  - The number of sub-pixels by panel type: **TBD**
- Leaving the screen fixed on a stationary image for an extended period of time may cause afterimage burn-in or defective pixels.
  - Activate power-saving mode or a dynamic screen saver if you will not be using the product for an extended period of time.

## Prevention of Afterimage Burn-in

### What is afterimage burn-in?

Afterimage burn-in should not occur when the LCD panel is operating normally. Normal operation refers to a continuously changing video pattern. If the LCD panel displays a fixed pattern for an extended period of time a slight voltage difference may occur between the electrodes in pixels that control the liquid crystals.

Such a voltage difference between electrodes increases with time and makes the liquid crystals thinner. When this occurs, a previous image can remain on the screen when the pattern changes. To prevent this, the accumulated voltage difference should be reduced.

 Afterimage burn-in should not occur when an LCD panel is operating in proper conditions.

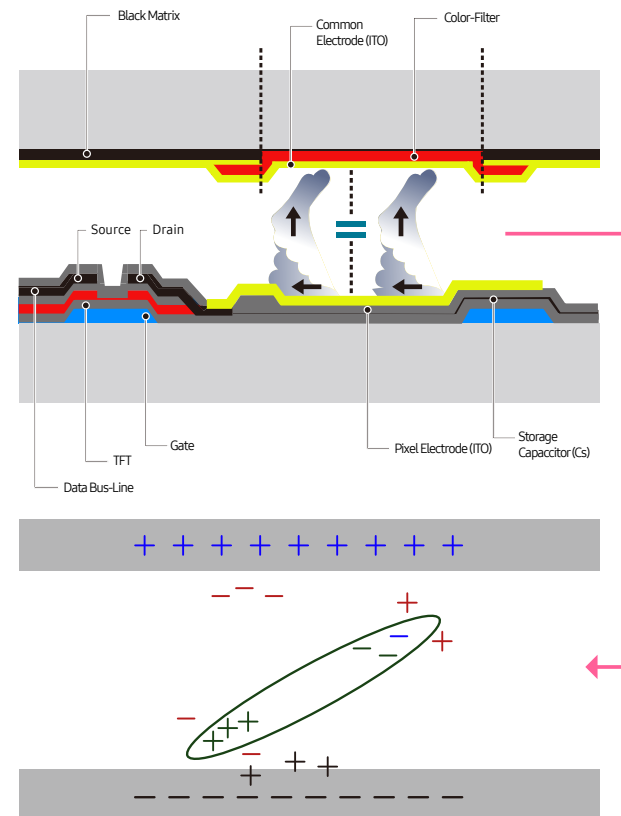



---

## License



The terms HDMI and HDMI High-Definition Multimedia Interface, and the HDMI Logo are trademarks or registered trademarks of HDMI Licensing LLC in the United States and other countries.

---

### Open Source Licence Notice

In the case of using open source software, Open Source Licences are available on the product menu. Open Source Licence Notice is written only English.

For information on the Open Source Licence Notice, contact the Samsung Customer Center or send email to [oss.request@samsung.com](mailto:oss.request@samsung.com).

---

## FCC Information

This device complies with part 15 of the FCC Rules. Operation is subject to the following two conditions :

- (1) This device may not cause harmful interference, and
- (2) This device must accept any interference received, including interference that may cause undesired operation.

Note: This equipment has been tested and found to comply with the limits for CLASS B digital device, pursuant to Part 15 of FCC Rules. These limits are designed to provide reasonable protection against harmful interference when the equipment is operated in a commercial environment. This equipment generates, uses and can radiate radio frequency energy and, if not installed and used in accordance with the instructions, may cause harmful interference to radio communications. However, there is no guarantee that interference will not occur in a particular installation. If this equipment does cause harmful interference to radio or television reception, which can be determined by turning the equipment off and on, the user is encouraged to try correct the interference by one or more of the following measures:

- 1.1. Reorient or relocate the receiving antenna.
- 1.2. Increase the separation between the equipment and receiver.
- 1.3. Connect the equipment into an outlet on a circuit different from that to which receiver is connected.
- 1.4. Consult the dealer or experienced radio/TV technician for help.

## WARNING

Changes or modifications not expressly approved by the manufacturer could void the user's authority to operate the equipment.

## Information for OEM Integrator

This device is intended only for OEM integrators under the following conditions:

- 1) The antenna must be installed such that 20 cm is maintained between the antenna and users, and
- 2) The transmitter module may not be co-located with any other transmitter or antenna.

### End product labelling

The label for end product must include "Contains FCC ID: A3LWCM730Q".

"CAUTION : Exposure to Radio Frequency Radiation.

This equipment complies with FCC radiation exposure limits set forth for an uncontrolled environment. This equipment must be installed and operated with minimum distance of 20 cm between the radiator and your body. This transmitter module is authorized only for use in device where the antenna may be installed such that 20 cm may be maintained between the antenna and users."