



VIDEO CASSETTE RECORDER

SV-623B
SV-620B

Instruction Manual



Safety Precautions



CAUTION
RISK OF ELECTRIC SHOCK
DO NOT OPEN



CAUTION. TO REDUCE THE RISK OF ELECTRIC SHOCK, DO NOT REMOVE REAR COVER. NO USER SERVICEABLE PARTS INSIDE. REFER TO QUALIFIED SERVICE PERSONNEL.

IMPORTANT NOTE

The mains lead on this equipment is supplied with a moulded plug incorporating a fuse. The value of the fuse is indicated on the pin face of the plug. If it requires replacing, a fuse approved to BS1362 of the same rating must be used.

Never use the plug with the fuse cover omitted if the cover is detachable. If a replacement fuse cover is required, it must be of the same colour as the pin face of the plug. Replacement covers are available from your dealer.

If the fitted plug is not suitable for the power points in your house or the cable is not long enough to reach a power point, you should obtain a suitable safety approved extension lead or consult your dealer for assistance.

However, if there is no alternative to cutting off the plug, remove the fuse and then safely dispose of the plug. Do not connect the plug to a mains socket, as there is a risk of shock hazard from the bared flexible cord.

IMPORTANT

The wires in the mains lead are coloured in accordance with the following code: -

BLUE = NEUTRAL BROWN = LIVE

As these colours may not correspond with the coloured markings identifying the terminals in your plug, proceed as follows: -

The wire coloured BLUE must be connected to the terminal marked with the letter N or coloured BLUE or BLACK. The wire coloured BROWN must be connected to the terminal marked with the letter L or coloured BROWN or RED.

WARNING: DO NOT CONNECT EITHER WIRE TO THE EARTH TERMINAL WHICH IS MARKED WITH THE LETTER E OR BY THE EARTH SYMBOL \perp , OR COLOURED GREEN OR GREEN AND YELLOW.

2



DANGER

This symbol is intended to alert you to the presence of dangerous voltage within the product.



CAUTION

This symbol is intended to alert you to the presence of important instructions accompanying the product.

About this manual

Thank you for purchasing a Samsung Video Cassette Recorder (VCR). Your Owner's Instructions contain much valuable information on setting up and using your VCR. Please take the time to read them as they will help you take full advantage of your VCR's features.

The instructions in this manual are for models, SV-623B and SV-620B. Before you start reading this manual please check your model number. It is displayed on the rear of the VCR.

- ★(SV-623B): Exceptions only for a certain model, for example SV-623B.
- Gray shaded areas marked with a star indicate instructions that are only relevant to one model.

Features Chart

Feature	SV-623B	SV-620B
VIDEOPUS+ Recording	●	
AV2 IN socket	●	●
Format 16:9	●	●
Child Door Lock	●	●
IPC (Intelligent Picture Control)	●	●
Quick Programming	●	●
Auto Clock Setting	●	●

3

Contents

◆ FOREWORD	
■ Safety Instructions.....	6
◆ VCR OVERVIEWS	
■ Front View of the VCR.....	7
■ Rear View of the VCR.....	7
■ Infrared Remote Control.....	8
■ Display Indicators.....	9
■ Accessories.....	9
◆ CONNECTING YOUR VIDEO CASSETTE RECORDER	
■ Deciding How to Connect Your VCR.....	10
■ Connecting Your VCR to the TV using the Coaxial Cable.....	11
■ Connecting Your VCR to the TV using the SCART Cable.....	11
■ Connecting Your VCR to the Satellite receiver or Other Equipment.....	12
■ Plug &Auto Set Up.....	13
■ Tuning Your Television for the VCR.....	14
◆ SETTING UP YOUR VIDEO CASSETTE RECORDER	
■ Inserting Batteries in the Remote Control.....	15
■ Setting the Date and Time.....	15
■ Displaying/Hiding On-Screen Information.....	16
■ Setting the VCR Output Channel.....	16
■ Presetting the Stations Automatically.....	17
■ Presetting the Stations Manually.....	18
■ Clearing a Preset Station.....	19
■ Changing the Preset Station Table.....	20
◆ RECORDING TELEVISION BROADCASTS	
■ Selecting the Cassette Type.....	21
■ Selecting the Recording Speed.....	21
■ NICAM.....	22
■ Protecting a Recorded Cassette.....	23
■ Recording a Programme Immediately.....	23
■ Recording a Programme with Automatic Stop.....	24
■ Using the VIDEOPLUS+ Feature (SV-623B Only).....	25
■ Modifying VIDEOPLUS+ Programming (SV-623B Only).....	26
■ Using the Quick Programming Feature.....	27
■ Checking a Preset Recording.....	28
■ Cancelling a Preset Recording.....	28
◆ PLAYING BACK	
■ Playing a Cassette.....	29
■ Adjusting Picture Alignment Manually.....	29
■ Intelligent Picture Control.....	30
■ Format 16:9 Wide screen.....	30
■ Selecting the Colour Mode.....	31
■ Selecting the Audio Output Mode.....	32

Contents (cont.)

◆ SEARCHING FOR A SEQUENCE	
■ Playing a Cassette in Slow Motion.....	33
■ Playing a Sequence Frame by Frame.....	34
■ Playing a Sequence at Variable Speeds.....	34
■ Searching for a Specific Sequence.....	35
■ Auto Repeat Play.....	36
■ Interval Repeat Play.....	36
■ Using the Tape Counter.....	37
◆ ADVANCED RECORDING FEATURES	
■ Using the Assemble Edit Function.....	38
■ Recording from Another VCR or Camcorder.....	38
◆ OTHER FUNCTIONS AND USEFUL RECOMMENDATIONS	
■ Auto Power Off.....	39
■ Resetting Your VCR.....	39
■ Child door Lock System.....	39
■ Technical Specifications.....	40
◆ SOLVING PROBLEMS	
■ Problems and Solutions.....	41
■ Service Centers List.....	42

Symbols



Safety Instructions

GB

The following illustrations represent precautions.



The lightning bolt is a warning sign alerting you to dangerous voltage inside the product. DO NOT OPEN THE VCR. Refer to service personnel.

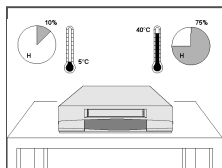

Do NOT expose the VCR to extreme temperature conditions (below 5°C and above 40°C) or to extreme humidity conditions (less than 10% and more than 75%).

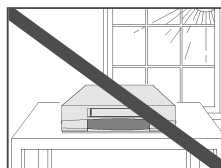

Do NOT expose the VCR to direct sunlight.

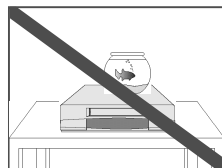

Do NOT expose the VCR to any liquids.

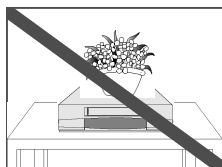

Do NOT place any objects on the VCR or remote control.

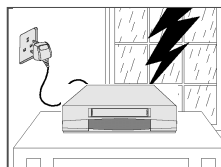

During a storm and/or lightning, unplug the VCR from the mains socket and aerial.

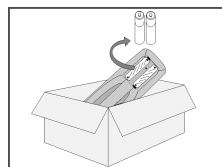

If the remote control is not used for a long period of time, remove the batteries and store it in a cool, dry place.

THIS DEVICE IS NOT FOR USE IN INDUSTRIAL ENVIRONMENTS

Front View of the VCR

GB

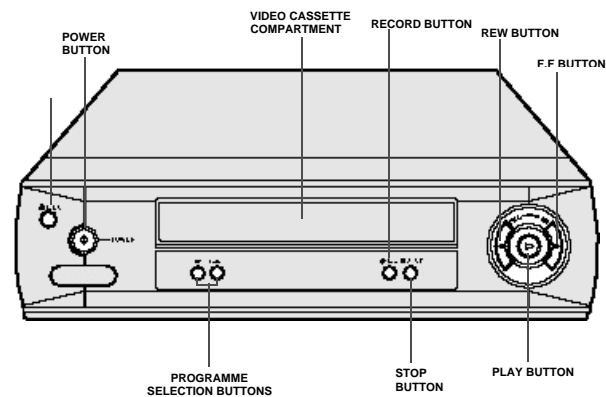

Rear View of the VCR

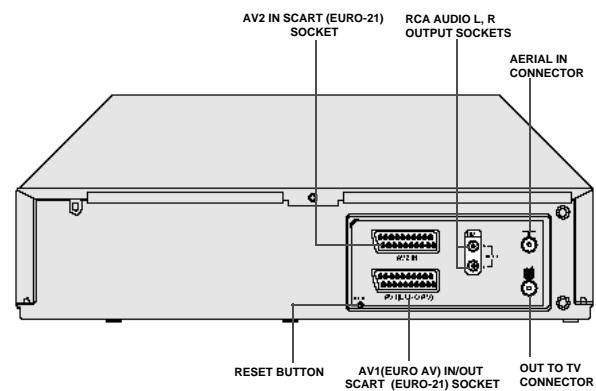

Infrared Remote Control

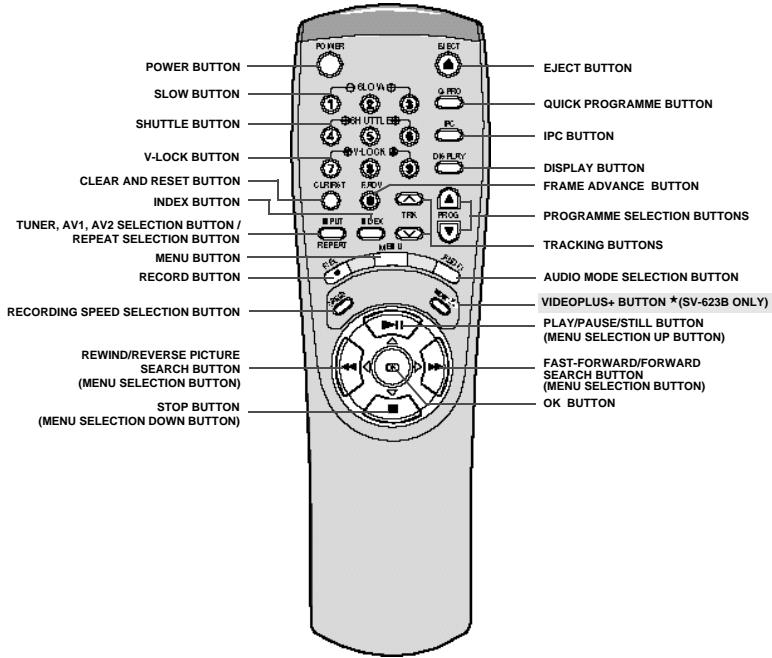

Display Indicators

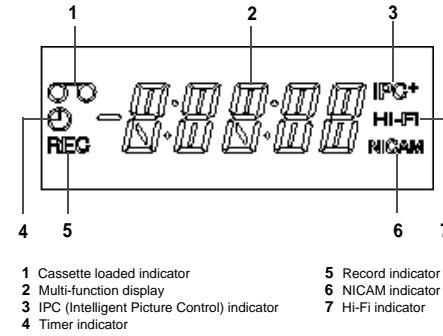

Accessories

You have just purchased a SAMSUNG Video Cassette Recorder (VCR). Together with your VCR, you will find the following accessories in the box.

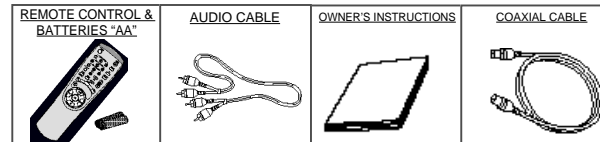











Deciding How to Connect Your VCR

You must take into account various factors when connecting audio or video systems:

- ◆ Types of connectors available on your systems
- ◆ Systems connected permanently to the VCR (satellite receiver for example) or temporarily (camcorder for example)

Your VCR is equipped with the following connectors.

Connector	Location	Type	Direction	Recommended Use
AV1(EURO AV)	Rear 	SCART	In/Out 	<ul style="list-style-type: none"> ◆ Television ◆ Satellite receiver ◆ Other VCR
AV2 IN	Rear 	SCART	In 	<ul style="list-style-type: none"> ◆ Satellite receiver ◆ Other VCR
Audio output	Rear 	Audio RCA	Out 	◆ Audio Hi-Fi system
OUT TO TV	Rear 	75 coaxial	Out 	◆ Television
IN FROM ANT.	Rear 	75 coaxial	In 	<ul style="list-style-type: none"> ◆ Aerial ◆ Cable television network ◆ Satellite receiver

 Whenever you connect an audio or video system to your VCR, ensure that all elements are switched off.



Refer to the documentation supplied with your equipment for detailed connection instructions and associated safety precautions.

Connecting Your VCR to the TV using the Coaxial Cable

To receive television programmes a signal must be received from one of the following sources:

- ◆ An outdoor aerial
- ◆ An indoor aerial
- ◆ A cable television network
- ◆ A satellite receiver

 Make sure that both the television and the VCR are switched off before connecting the cables.

- 1 Remove the aerial or network input cable from the television.
- 2 Connect this cable to the 75 coaxial socket marked  on the rear of your VCR.
- 3 Plug the coaxial cable supplied into the  socket on your VCR.
- 4 Plug the other end of the coaxial cable into the connector previously used for the aerial on the television.
- 5 To obtain better quality pictures and sound on your television, you can also connect your VCR to the television via the SCART cable (see section below) if your television is equipped with this type of connection.

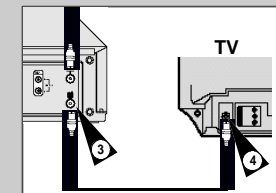
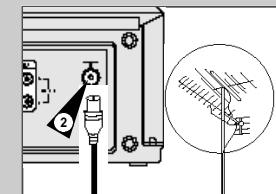

Connecting Your VCR to the TV using the SCART Cable

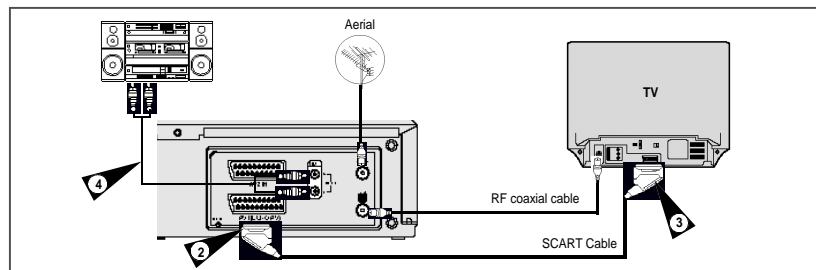

You can connect your VCR to the television using the SCART cable if the appropriate input is available on the television. You thus:

- ◆ Obtain better quality sound and pictures
- ◆ Simplify the setting up procedure of your VCR

 Regardless of the type of connection chosen, you must always connect the coaxial cable supplied. Otherwise, no picture will be visible on the screen when the VCR is switched off.

◆ Make sure that both the television and the VCR are switched off before connecting the cables.

You can connect your VCR to a Hi-Fi system.

Example: You wish to take advantage of the quality of your Hi-Fi stereo system when watching a programme or recording via your VCR.

- 1 Connect the coaxial cable as indicated in the above section.
- 2 Connect one end of the SCART cable to the AV1(EURO AV) socket on the rear of the VCR.
- 3 Plug the other end into the appropriate connector on the television.
- 4 Plug the RCA Audio cable with stereo system into the AUDIO out socket on the rear of the VCR.

Connecting Your VCR to the Satellite receiver or Other Equipment

GB

You can connect your VCR to the Satellite receiver or other VCR using the SCART cable if the appropriate outputs are available on the equipment chosen. The following illustrations give a few examples of the connection possibilities.

1. AV1(EURO AV): By means of 21-pin Scart Cable

Plug the SCART Cable with satellite receiver or other equipment into the AV1(EURO AV) socket on the rear of the VCR.

After making this connection, select the source by pressing the INPUT button for the AV1 input sources.

2. By means of RF Coaxial Cable

After making this connection, you must preset the station received through the satellite tuner. RF output channel of the satellite receiver should be adjusted away from channel 60, which is used by the VCR, e.g. re-adjust to channel 65.

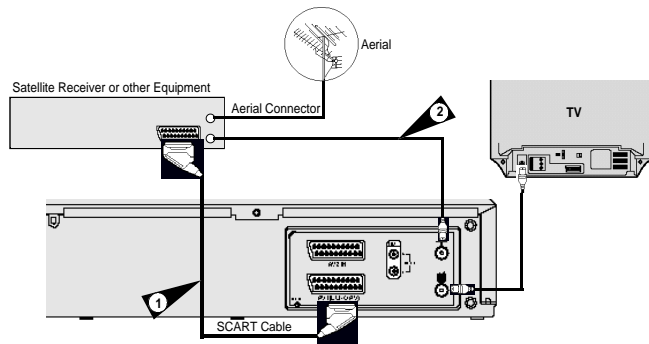

1. AV2 IN: By means of 21-pin Scart Cable

Plug the SCART Cable with satellite receiver or other equipment into the AV2 IN socket on the rear of the VCR.

After making this connection, select the source by pressing the INPUT button for the AV2 input sources.

2. By means of RF Coaxial Cable

After making this connection, you must preset the station received through the satellite tuner. RF output channel of the satellite receiver should be adjusted away from channel 60, which is used by the VCR, e.g. re-adjust to channel 65.

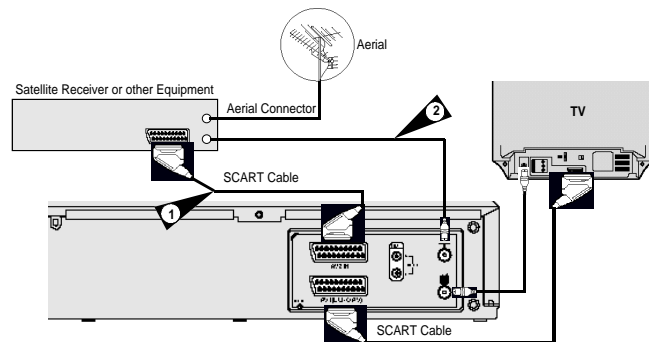

12

Plug & Auto Set Up

GB

Your VCR will automatically set itself up when it is plugged into the mains for the first time. TV stations will be stored in memory. The process takes a few minutes. Your VCR will then be ready for use.

- 1 Connect the coaxial cable as indicated on page 11. (Connecting Your VCR to the TV Using the Coaxial Cable)
- 2 Plug the VCR into the mains. It will automatically tune itself in and store TV stations in the memory.
- 3 The process will finish after a few minutes. Then the VCR automatically switches itself off.

➤ Now, you only have to switch the VCR on and it is ready for use.

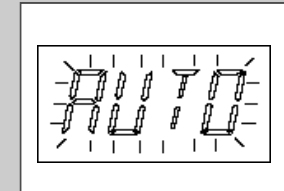
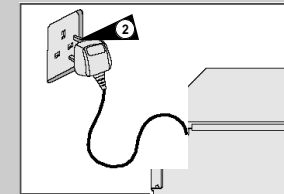
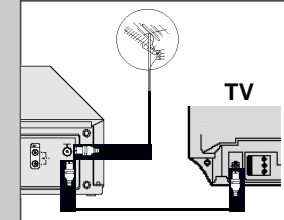

13

Tuning Your Television for the VCR

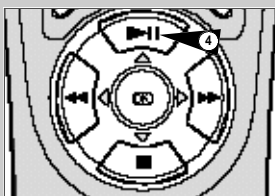
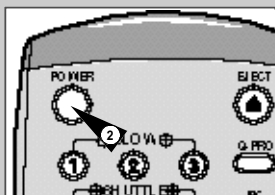

You must tune your television for the VCR only if you are not using a Scart cable

➤ To view pictures from your VCR when a Scart cable is used, the television must be set to the audio/video mode (AV).

- 1 Switch on the television.
- 2 Switch on the VCR by pressing POWER on the front of the VCR or POWER on the remote control.
- 3 Select a programme position on the television to be reserved for use with your VCR.
- 4 Insert the video cassette in the VCR. Check that the VCR starts reading the cassette; if not, press **▶||** button.
- 5 Start a scan on your television or set the television to UHF channel 60.
- 6 Fine tune the television until the pictures and sound are obtained clearly.
- 7 If you cannot find the pictures and sound, or there is interference from nearby channels, it may be necessary to change the setting of the VCR output channel (see Setting the VCR Output Channel on page 16 and Problems and Solutions on page 41).
- 8 When the picture and sound are perfectly clear, store this channel at the desired programme position on the television.
Result: That programme is now reserved for use with your VCR.

Inserting Batteries in the Remote Control

GB

You must insert or replace the batteries in the remote control when you:

- ◆ Purchase the video cassette recorder
- ◆ Find that the remote control is no longer working correctly

- 1 Push the tab in the direction of the arrow to release the battery compartment cover on the rear of the remote control.
- 2 Insert two AA, R6 or equivalent batteries, taking care to respect the polarities:
 - ◆ + on the battery with + on the remote control
 - ◆ - on the battery with - on the remote control
- 3 Replace the cover by aligning it with the base of the remote control and pushing it back into place.

- Do not mix different battery types (manganese and alkaline for example).

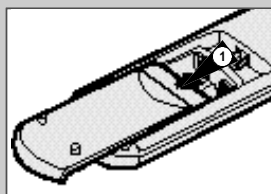

Setting the Date and Time

Your VCR contains a 24-hour clock and calendar used to:

- ◆ Automatically stop programme recording
- ◆ Preset your VCR to record a programme automatically

You must set the date and time when:

- ◆ You purchase the video cassette recorder
- ◆ The power supply remains off for more than 60 minutes

- ☞
- ◆ The date and time are set automatically from the broadcast signal, but this function will not operate if there is no Teletext signal.
 - ◆ Do not forget to reset the time when you change clocks from winter to summer time and vice versa.

- 1 Press MENU on the remote control.
Result: The programming menu is displayed.
- 2 Press the ▲ or ▼ buttons, until the cursor is placed in front of the **CLOCK SET** option.
- 3 Press the ▶ button to select this option.
Result: The **CLOCK SET** menu is displayed.
- 4 Press ◀ or ▶ to select the hour, minutes, day, month and year.
Result: The option selected flashes.
- 5 Press the ▲ or ▼ buttons to increase or decrease the value.
Result: The day of the week is displayed automatically.
 - You can hold the ▲ or ▼ buttons down to scroll more quickly through the values.
- 6 On completion, press MENU twice to exit the menu.

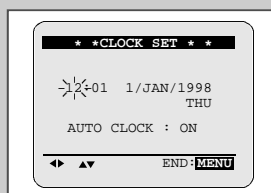
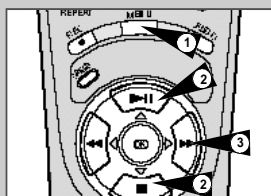

Displaying/Hiding On-Screen Information

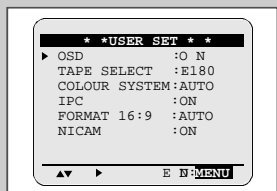
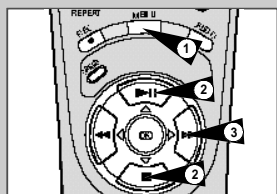

Your VCR displays most information both on the VCR and the television.

You can choose to display or hide this information on the television screen (except for the Index, Programming MENU and VIDEOPLUS+ functions * (SV-623B only), which cannot be hidden).

- Press MENU on the remote control.
Result: The programming menu is displayed.
- Press the corresponding Δ or ∇ buttons, until the cursor is placed in front of the **USER SET** option.
- Press the \blacktriangleright button to select this option.
Result: The **USER SET** menu is displayed.
- Press the corresponding Δ or ∇ buttons, until the cursor is placed in front of the **OSD** option.
- To... Press \blacktriangleleft or \blacktriangleright , until...
Display on-screen information **ON** is displayed.
Hide on-screen information **OFF** is displayed.
- On completion, press MENU twice to exit the menu.

Setting the VCR Output Channel

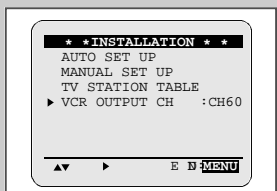
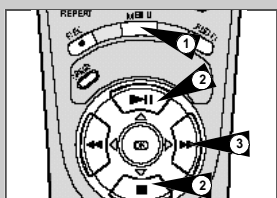

Your VCR output channel may need to be changed if the pictures suffer from interference or if your TV cannot find the pictures. Also, you can change the VCR output channel to adjust the frequency in which information is displayed on the screen.

- Press MENU on the remote control.
Result: The programming menu is displayed.
- Press the corresponding Δ or ∇ buttons, until the cursor is placed in front of the **INSTALLATION** option.
- Press the \blacktriangleright button to select this option.
Result: The **INSTALLATION** menu is displayed.
- Press the Δ or ∇ buttons, until the cursor is placed in front of the **VCR OUTPUT CH** option.
- Select the required output channel (CH21-CH69) by pressing the \blacktriangleleft or \blacktriangleright buttons.
- On completion, press MENU twice to exit the menu. Then tune your television again (see page 14).

Presetting the Stations Automatically

You do not need to preset the stations if you have already set them automatically (see Plug & Auto Set Up on page 13).

Your VCR contains a built-in tuner used to receive television broadcasts.

You must preset the stations received through the tuner. This can be done:

- ◆ Plug & Auto Set up (see page 13)
- ◆ Automatically
- ◆ Manually (see page 18)

You can store up to 99 stations.

- Press the MENU button on the remote control.
Result: The programming menu is displayed.
- Press the corresponding Δ or ∇ buttons, until the cursor is placed in front of the **INSTALLATION** option.
- Press the \blacktriangleright button to select this option.
Result: The **INSTALLATION** menu is displayed.
- Press the corresponding Δ or ∇ buttons, until the cursor is placed in front of the **AUTO SET UP** option.
And then press the \blacktriangleright button to select this option.
Result: A message appears, indicating that any channels already preset on your VCR will be deleted.
- Press OK to start the auto scanning.
Result:
 - ◆ The **PLEASE WAIT** indication flashes on the television screen.
 - ◆ The first frequency band is scanned and the first station found is displayed and stored.
 - ◆ The VCR then searches for the second station and so on.
 - ◆ When the automatic scanning procedure has finished, the VCR switches automatically to programme 1.
- If you wish to cancel the auto scanning before the end, press the MENU button three times to exit the menu.

- ◆ The time and date are set automatically from the broadcast signal. If the signal is weak or ghosting occurs, the time and date may not be set automatically. In this case, they should be set manually (see page 15).
- ◆ Once the auto scanning procedure has finished, some stations may have been stored more than once; select the stations with the best reception and delete the ones no longer required (see page 19).

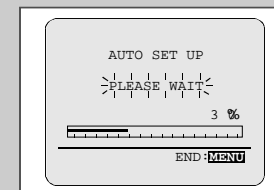
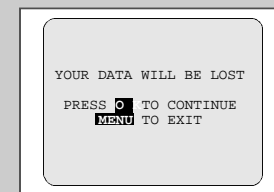
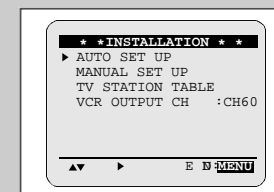
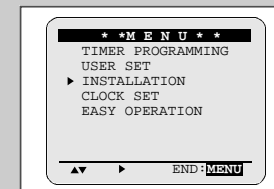
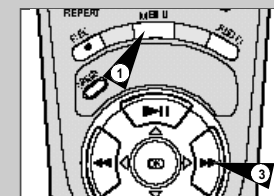

Presetting the Stations Manually

GB

```

* * M E N U * *
TIMER PROGRAMMING
USER SET
▶ INSTALLATION
CLOCK SET
EASY OPERATION
END:MENU
  
```

```

* * I N S T A L L A T I O N * *
AUTO SET UP
▶ MANUAL SET UP
TV STATION TABLE
VCR OUTPUT CH :CH60
E B:MENU
  
```

```

* * M A N U A L   S E T   U P   * *
PR      : 1
▶ CH    : 021
MPT     : -
MEMORY : 0
E B:MENU
  
```

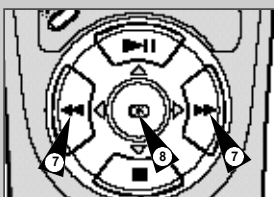

Your VCR contains a built-in tuner used to receive television broadcasts.

You must preset the stations received through the tuner. This can be done:

- ◆ Plug & Auto Set up (see page 13)
- ◆ Automatically (see page 17)
- ◆ Manually

You can store up to 99 stations.

You do not need to preset the stations manually if you have already set them automatically.

- 1 Press the MENU button on the remote control.
Result: The programming menu is displayed.
- 2 Press the corresponding Δ or ∇ buttons, until the cursor is placed in front of the **INSTALLATION** option.
- 3 Press the \triangleright button to select this option.
Result: The **INSTALLATION** menu is displayed.
- 4 Press the corresponding Δ or ∇ buttons, until the cursor is placed in front of the **MANUAL SET UP** option.
- 5 Press the \triangleright button to select a **MANUAL SET UP** option.
- 6 Press the ∇ button until the cursor is placed in front of the channel number.
Result: The frequency band is scanned and the first station found is displayed.
- 7 Press the \triangleleft or \triangleright buttons to start scanning.
Result: The frequency band is scanned and the first station found is displayed.
- 8 **If you... Then...**

<p>Wish to store the station displayed</p>	<ul style="list-style-type: none"> ◆ Press the ∇ button once to place the cursor in front of the MPT. ◆ Press the \triangleleft or \triangleright buttons to adjust the picture, if necessary. ◆ Press the ∇ button until the cursor is placed in front of the PR (Programme number). ◆ Press the \triangleleft or \triangleright buttons to select a programme number as required. ◆ Press OK to store the station
<p>Do <u>not</u>wish to store the station displayed</p>	<ul style="list-style-type: none"> ◆ Press the \triangleleft or \triangleright buttons to go on scanning the frequency band and display the next station ◆ Go back to the beginning of Step 8
- 9 Repeat this procedure from Step 6 onwards, until all the required stations have been stored.
- 10 On completion, press the MENU button three times to exit the menu.

Clearing a Preset Station

GB

If you have stored a TV station:

- ◆ That you do not require
- ◆ At the wrong programme position

you can cancel it.

- 1 Press the MENU button on the remote control.
- 2 Press the corresponding Δ or ∇ buttons, until the cursor is placed in front of the **INSTALLATION** option.
- 3 Press the \triangleright button to select this option.
Result: The **INSTALLATION** menu is displayed.
- 4 Press the corresponding Δ or ∇ buttons, until the cursor is placed in front of the **TV STATION TABLE** option.
- 5 Press the \triangleright button to select this option.
Result: The **TV STATION TABLE** menu is displayed.
- 6 Press the corresponding Δ or ∇ buttons, until the cursor is placed in front of the required preset TV station. (**PR**)
- 7 Press the CLR/RST button.
Result: PLEASE WAIT is displayed.
- 8 Repeat the same procedure from Step 6 onwards until all the required stations have been cleared.
- 9 On completion, press the MENU button three times to exit the menu.

```

* * M E N U * *
TIMER PROGRAMMING
USER SET
▶ INSTALLATION
CLOCK SET
EASY OPERATION
END:MENU
  
```

```

* * T V   S T A T I O N   T A B L E   * *
P R  CH  NAME
▶ 1  021  ----
  2  025  ----
  3  030  ----
  4  065  ----
  5  055  ----
SET:  SORT:
DELETE: CLR/RST  MENU
  
```

```

* * T V   S T A T I O N   T A B L E   * *
P R  CH  NAME
▶ 1  021  ----
  2  025  ----
  3  030  ----
  4  065  ----
  5  055  ----
PLEASE WAIT
  
```

Changing the Preset Station Table

GB

```

* *TV STATION TABLE * *
P R CH NAME
▶ 1 021 ----
  2 025 ----
  3 030 ----
  4 065 ----
  5
▲▼ SET:▶ SORT:○
DELETE: CLR/RST MENU
  
```

```

* *TV STATION TABLE * *
P R CH NAME
  1 021 ----
  2 025 ----
  3 030 ----
▶ 4 (065 ---- )
  5
(SORT : 4 - 4 )
▲▼ EXECUTE:○ MENU
  
```

```

* *TV STATION TABLE * *
P R CH NAME
▶ 1 (065 ---- )
  2 025 ----
  3 030 ----
  4 065 ----
  5
(SORT : 4 - 1 )
▲▼ EXECUTE:○ MENU
  
```

```

* *TV STATION TABLE * *
P R CH NAME
▶ 1 065 ----
  2 021 ----
  3 025 ----
  4 030 ----
  5
▲▼ SET:▶ SORT:○
DELETE: CLR/RST MENU
  
```

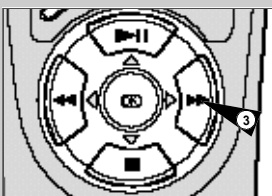

20

You can rearrange the preset TV stations according to your own preferences:

- ◆ Programme number assigned to the station
- ◆ Name assigned to the station

- 1 Press the MENU button on the remote control.
- 2 Press the corresponding ▲ or ▼ buttons, until the cursor is placed in front of the **INSTALLATION** option.
- 3 Press the ▶ button to select this option.
Result: The **INSTALLATION** menu is displayed.
- 4 Press the corresponding ▲ or ▼ buttons, until the cursor is placed in front of the **TV STATION TABLE** option.
- 5 Press the ▶ button to select this option.
Result: The **TV STATION TABLE** menu is displayed.
- 6 Press the corresponding ▲ or ▼ buttons, until the cursor is placed in front of the required preset TV programme.
Result: The selected station is displayed at the same time on the television screen.
- 7 To change the programme number assigned to a station (PR4 instead of PR1 for example):
 - ◆ Press OK
 - ◆ Press the ▲ or ▼ buttons until the cursor is placed in front of the programme to which the station is to be moved
 - ◆ Press OK again
- 8 To change the programme's name, press the ▶ button.
Result: The first letter of the name flashes.
- 9

To...	Then...
Select a character in the name	Press the ▲ or ▼ button until the required character is displayed (letters, numbers or "-" character).
Move to the next or previous character	Press the ▶ or ◀ buttons respectively.
- 10 Press the ▶ button again to confirm all your choices and move to the next station; you can modify this station by repeating the same procedure from Step 6 onwards.
- 11 On completion, press the MENU button three times to exit the menu.

Selecting the Cassette Type

If you wish to use the tape counter to display the time remaining on a cassette, you must indicate the type of cassette inserted.

- 1 Press MENU on the remote control.
Result: The programming menu is displayed.
- 2 Press the ▲ or ▼ buttons, until the cursor is placed in front of the **USER SET** option.
- 3 Press the ▶ button to select this option.
- 4 Press the corresponding ▲ or ▼ buttons, until the cursor is placed in front of the **TAPE SELECT** option.
- 5 Press the ◀ or ▶ buttons as many times as required, until the correct cassette length is displayed.
- 6 Press MENU twice to exit the menu.

GB

```

* *USER SET * *
OSD : O N
▶ TAPE SELECT : E180
COLOUR SYSTEM: AUTO
IPC : ON
FORMAT 16:9 : AUTO
NICAM : ON
▲▼ E D MENU
  
```

Selecting the Recording Speed

You can record a cassette at two different speeds:

- ◆ **SP (Standard Play)**
 - ◆ **LP (Long Play)**
- In Long Play modes:**
- ◆ Each cassette lasts twice as long
 - ◆ The recording is of a slightly lower quality

To record a cassette... Press the **SPEED** button on the remote control, until...

In standard play mode SP is displayed.
In long play mode LP is displayed.

Type	Recording Time (in SP)
E-180	180 mins. or 3 hours
E-240	240 mins. or 4 hours
E-260	260 mins. or 4 hours and 20 mins.
E-300	300 mins. or 5 hours

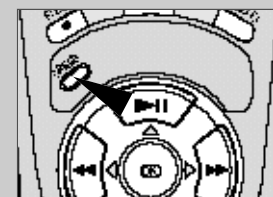

21

NICAM

GB

```

* *USER SET * *
OSD       :O N
TAPE SELECT :E180
COLOUR SYSTEM:AUTO
IPC       :ON
FORMAT 16:9 :AUTO
▶ NICAM   :ON
  
```

▲▼ ▶ E D:MENU

NICAM programmes are divided into 3 types. NICAM Stereo, NICAM Mono and Bilingual (transmission in another language). NICAM programmes are always accompanied by a standard mono sound broadcast and you can select the desired sound. Please refer to page 32.

- Press MENU on the remote control.
Result: The programming menu is displayed.
- Press the corresponding ▲ or ▼ buttons, until the cursor is placed in front of the **USER SET** option.
- Press the ▶ button to select this option.
Result: The **USER SET** menu is displayed.
- Press the corresponding ▲ or ▼ buttons, until the cursor is placed in front of the **NICAM** option.
- | To... | Press ◀ or ▶, until... |
|------------|--|
| Mono mode | OFF is displayed.
OFF: Only set at this position to record the standard mono sound during a NICAM broadcast if the stereo sound is distorted due to inferior reception conditions. |
| NICAM mode | ON is displayed.
ON: Normally set at this position. |
- On completion, press MENU twice to exit the menu.

Protecting a Recorded Cassette

GB

Video cassettes have a safety tab to prevent accidental erasure. When this tab has been removed, you cannot record on the tape.

- If you wish to protect a cassette, break off the tab using a small screwdriver.
- To re-record over a protected cassette (safety tab broken), cover the hole with adhesive tape.

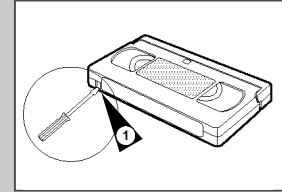

Recording a Programme Immediately

Before recording a programme, you must have preset the corresponding station (unless you are recording via an external video source). If you have not done so, refer to pages 17 and 18.

- Switch on the television.
- To monitor the programme being recorded, select the television channel reserved for use with your VCR (or the AV input if used).
- Insert the cassette on which the programme is to be recorded, with the window visible and the safety tab intact or the opening covered with adhesive tape.
Result: The VCR is switched on automatically.
- Select:
 - The station to be recorded using the PROG (▲ or ▼) buttons or
 - The AV1 or AV2 source using the INPUT button for a satellite tuner or external video source**Result:** The station number is displayed and the programme can be seen on the television.
- Select the recording speed by pressing the SPEED button as many times as required (see page 21).
- Hold REC (■) down for a while to start recording.
Result: The record indicator appears on the television and VCR display. An index is recorded on the tape (see page 35).
- To stop recording, press ■ once.

-
- If the cassette is ejected when you start recording, check that the safety tab is intact or the opening is covered with adhesive tape.
 - If you reach the end of the tape while recording, the cassette rewinds automatically.

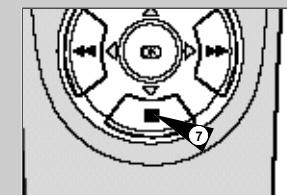
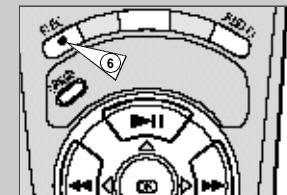

Recording a Programme with Automatic Stop

GB

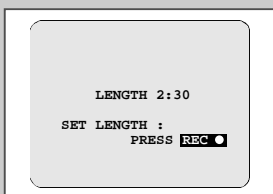
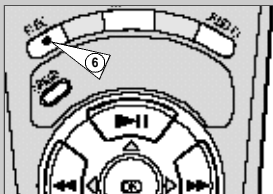
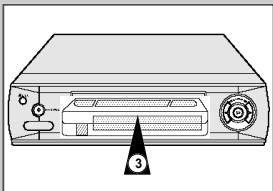

This function enables you to record up to nine hours (LP) of programmes.

Your VCR stops automatically after the requested length of time.

- 1 Switch on the television.
- 2 To monitor the programme being recorded, select the television channel reserved for use with your VCR (or the AV input if used).
- 3 Insert the cassette on which the programme is to be recorded, with the window visible and the safety tab intact or the opening covered with adhesive tape.
Result: The VCR is switched on automatically.
- 4 Select:
 - ◆ The station to be recorded using the PROG (▲ or ▼) buttons
or
 - ◆ The AV1 or AV2 source using the INPUT button for a satellite tuner or external video sourceResult: The channel number is displayed and the programme can be seen on the television.
- 5 Select the recording speed by pressing the SPEED button as many times as required (see page 21).
- 6 Hold the REC button (●) down for a while to start recording.
Result: The record indicator appears on the television screen and VCR display. An index is recorded on the tape (see page 35).
- 7 Press the REC button (●) several times to increase the recording time in:
 - ◆ 30-minute intervals up to four hours
 - ◆ 1-hour intervals up to nine hours (LP)Result: The length is displayed on the television displays. The selected programme is recorded for the length of time requested. At the end of that time, the VCR stops recording automatically.
- 8 If you wish to cancel the recording before the end, press POWER.



If the end of the tape is reached while recording:

- ◆ The recording stops
- ◆ The VCR automatically turns off

Using the VIDEOPLUS+ Feature ★ (SV-623B Only)

GB

Before presetting your VCR:

- ◆ Switch on both the television and your VCR
- ◆ Check that the date and time are correct
- ◆ Insert the cassette on which the programme is to be recorded (safety tab intact)

Up to six programmes can be preset.

- 1 Press the VIDEOPLUS+ button.

Result: A message is displayed to allow you to enter the VIDEOPLUS+ code.

☞ If all six programmes have been set, the message **TIMER IS FULL** is displayed. Refer to page 28 if you wish to cancel a preset recording.

- 2 Press the numeric buttons to enter the code opposite the programme that you wish to record in your television magazine.

➤ If you wish to correct the VIDEOPLUS+ code that you are entering:

- ◆ Press the ◀ button until the digit to be corrected is cleared
- ◆ Enter the correct digit

- 3 Press the MENU button.

Result: The information concerning the programme is displayed.

☞ When using the VIDEOPLUS+ function for the first time with stored stations, the programme number flashes. This one time, you must enter the station number manually by pressing the ▲ or ▼ buttons. Refer to the following page if:

- ◆ The programme number or times flash
- ◆ You wish to modify the programme

- 4 If the programme and times are correct, press the MENU button.

- 5 Press the POWER button to activate the timer.

- 6 Refer to page 28 if you wish to:

- ◆ Check that your VCR has been programmed correctly
- ◆ Cancel a preset recording



The numbers next to each TV programme listing are VIDEOPLUS+ code numbers, which allow you to programme your videorecorder instantly with the remote control. Tap in the VIDEOPLUS+ code for the programme you wish to record.

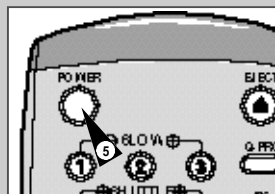
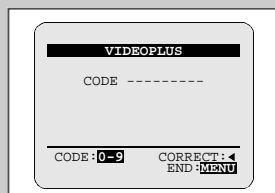
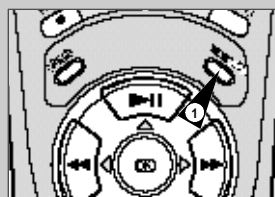

Modifying VIDEOPLUS+ Programming ★ (SV-623B Only)

If you wish to correct the programme displayed or modify certain elements, such as the recording speed, you can do so before you press MENU a second time to confirm.

If you wish to...	Then...
Select an input source other than the tuner (AV1 or AV2)	<ul style="list-style-type: none"> ◆ Press the ◀ or ▶ buttons, until the TR selection flashes. ◆ Press the INPUT button one or more times to change the input source selection. <p>Result: The programme number is replaced by:</p> <ul style="list-style-type: none"> • The A1 or A2 source using the INPUT button for a satellite tuner or external video source <p>➤ The input source must be selected before changing any other value.</p>
Record a programme every day (Monday to Sunday) at the same time	<ul style="list-style-type: none"> ◆ Press the ◀ or ▶ buttons, until the DAY selection flashes. ◆ Press the ▲ or ▼ buttons, until the DAY (Daily) value is displayed.
Record a programme every week on the same day and at the same time	<ul style="list-style-type: none"> ◆ Press the ◀ or ▶ buttons, until the DAY selection flashes. ◆ Press the ▲ or ▼ buttons, until the W (Week) value is displayed, followed by the required day. <p>Example: W-SA (Weekly Saturday)</p>
Extend the recording time	<ul style="list-style-type: none"> ◆ Press the ◀ or ▶ buttons, until the STOP selection flashes. ◆ Press the ▲ or ▼ buttons to increase or decrease the stop time.
Select the recording speed	<ul style="list-style-type: none"> ◆ Press the ◀ or ▶ buttons, until the recording speed selection flashes. ◆ Press the ▲ or ▼ buttons until the correct indication is displayed: <ul style="list-style-type: none"> • AUTO (Auto Tape Speed Select) : see page 27 • SP (Standard Play) • LP (Long Play)
Select the PDC recording	<ul style="list-style-type: none"> ◆ Press the ◀ or ▶ buttons, until the V/P selection flashes. ◆ Press the ▲ or ▼ buttons until the "ON" indication is displayed. <p>➤ Do not select PDC unless you are sure the programme you wish to record is broadcast with PDC. If you do set PDC ON (by selecting "ON" in the right - hand column on the screen), then you must set up the start-time EXACTLY according to the published TV schedule. Otherwise the timer recording won't take place.</p>

Using the Quick Programming Feature

The Quick Programming feature allows you to preset the VCR to record a programme up to one month before that programme is to be broadcast. Up to six programmes can be preset.

➤ Before presetting a recording, check that the date and time are correct.

- 1 - Insert the cassette and press the Q-PRO button or
 - ◆ Press MENU on the remote control.

Result: The programming menu is displayed.

 - ◆ Press the ▶ button to select **TIMER PROGRAMMING** option.

Result: The **TIMER PROGRAMMING** menu is displayed.
- 2 Press ▶ to select the input source.
- 3 Select the required station by pressing the ▲ or ▼ buttons or INPUT to select the AV1 or AV2 input sources.
- 4 Press ▶ to select the recording day.
- 5 Select the required day by pressing the ▲ or ▼ buttons.
- 6 Press ▶ to select the recording start time.
- 7 Select the required hour value by pressing the ▲ or ▼ buttons.
- 8 Press ▶ to select the minutes.
- 9 Select the required minute value by pressing the ▲ or ▼ buttons.
- 10 Press ▶ to select the recording end time.
- 11 Select the required recording end time by pressing the ▲ or ▼ buttons, following the same procedure as when selecting the recording start time.
- 12 Press ▶ to select the recording speed.
- 13 Press the ▲ or ▼ buttons to select the **SP** (Standard Play), **LP** (Long Play), **AUTO** (Auto Tape Speed Select) recording speeds.
- 14 Press ▶ to select the PDC recording mode.
- 15 Press the ▲ or ▼ buttons to toggle between the PDC mode (marked **ON**) and the non-PDC mode (marked **-**).
- 16 When you have finished, press the MENU button.
- 17 Press the POWER button to activate the timer.

Result: Before starting recording, the VCR compares the timer duration with the remaining time on the cassette.

➤ Auto Tape Speed Select. The VCR's "Auto Tape Speed Select" function compares the duration of the timer recording to the actual recording time remaining on the tape loaded. If there is insufficient tape to complete a timer recording in AUTO mode, the VCR automatically switches to LP mode to record the whole programme.

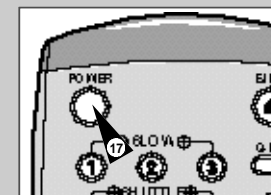
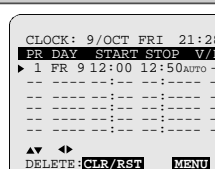
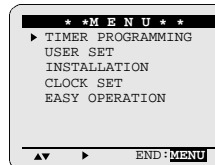

Checking a Preset Recording

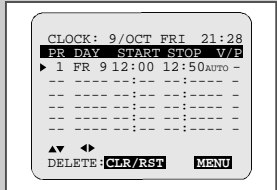
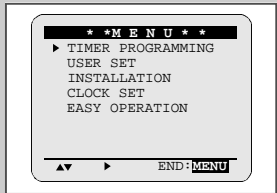
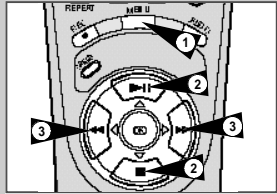

You can check your preset recordings:

- ◆ When you have finished presetting the VCR
- ◆ If you have forgotten which programmes will be recorded

- 1 - Press the Q-PRO button or
 - ◆ Press MENU on the remote control.
 - Result:** The programming menu is displayed.
 - ◆ Press the **▶** button to select **TIMER PROGRAMMING** option.
 - Result:** The **TIMER PROGRAMMING** menu is displayed.
- 2 Press the **▲** or **▼** buttons to select the required programme.
- 3 Press the **◀** or **▶** buttons to select and change any values as required. For more details, refer to the previous page.
- 4 On completion, press MENU twice.

Cancelling a Preset Recording

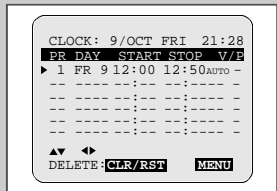

You can cancel any programmes that are:

- ◆ *Incorrect*
- ◆ *No longer required*

- 1 - Press the Q-PRO button or
 - ◆ Press MENU on the remote control.
 - Result:** The programming menu is displayed.
 - ◆ Press the **▶** button to select **TIMER PROGRAMMING** option.
 - Result:** The **TIMER PROGRAMMING** menu is displayed.
- 2 Select the programme to be cancelled by pressing the **▲** or **▼** buttons.
- 3 Press the CLR/RST button to cancel the selected programme.
 - Result:** All the recording information is deleted and the broadcast will not be recorded.
- 4 On completion, press MENU twice.

Playing a Cassette

This function allows you to play back any pre-recorded cassette.

- 1 Switch on both the television and your VCR.
- 2 Insert the video cassette to be played. If the safety tab on the cassette is intact, press **▶▶**. Otherwise, the cassette is played automatically.
 - When a cassette is loaded, the tape position is optimized automatically to reduce disturbance (Digital Auto Tracking). When playing a cassette, if the end of the tape is reached, the cassette is rewound automatically.
 - NTSC tapes can be played back but cannot be recorded with this VCR.
- 3 To... Then press...

Stop the playback	■ (STOP).
Eject the cassette	▲ (EJECT).

➤ One Touch Play.

For your convenience, you can playback tape with a simple touch of the PLAY (**▶▶**) button. One Touch Play can be used even when the power is off but a cassette is inserted.

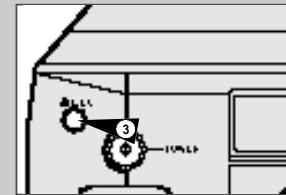
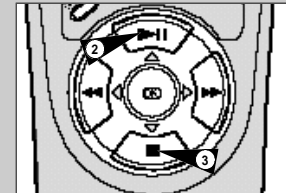

Adjusting Picture Alignment Manually

The Picture Adjustment feature allows you to adjust the alignment manually to obtain the best possible picture.

When noise bars or streaks appear during playback, adjust alignment manually by pressing the TRK (**↶** or **↷**) buttons until the picture is clear and stable.

- Result:**
- ◆ The tracking bar appears.
 - ◆ The image is adjusted.
 - ◆ The tracking bar disappears when you release the button.

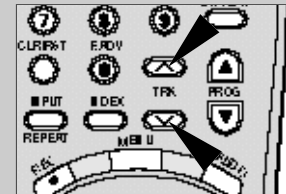

Intelligent Picture Control

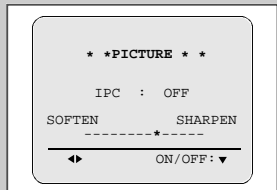
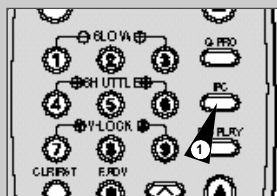

The Intelligent Picture Control Feature allows you to adjust the sharpness of the image automatically, according to your own preferences.

- During playback, press the IPC button.
Result: The **PICTURE** menu is displayed.
- Press the ∇ button to turn the IPC (intelligent picture control) option **ON** and **OFF**.
 - When intelligent picture control mode is **ON**, the sharpness of the image is adjusted automatically.
- To adjust the sharpness manually, select intelligent picture control mode **OFF**.
 - The horizontal picture adjusting appears.
- Press the \triangleleft or \triangleright buttons until the picture is displayed according to your preferences.
 - If you do not press a button within ten seconds, the **PICTURE** menu disappears automatically.
- On completion, press the IPC button again.

Format 16:9 (Wide screen)

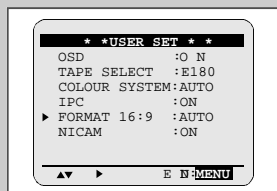
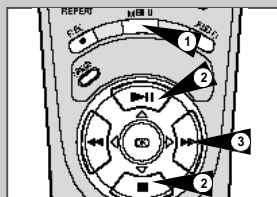

The VCR automatically adjusts the image to fill the wide TV screen when you play back a tape commercially available which is recorded in the wide screen format or when you record or play back a wide TV programme via the connect satellite, etc.

- Connect equipment compatible with wide screen, to the VCR using the 21 pin SCART cable.

- Press MENU on the remote control.
Result: The programming menu is displayed.
- Press the corresponding \triangle or ∇ buttons, until the cursor is placed in front of the **USER SET** option.
- Press the \triangleright button to select this option.
Result: The **USER SET** menu is displayed.
- Press the corresponding \triangle or ∇ buttons, until the cursor is placed in front of the **FORMAT 16:9** option.
- Press the \triangleright button to select **AUTO** \rightarrow **ON** \rightarrow **OFF**.

AUTO	Set when you use a wide TV. The VCR detects wide TV programmes and normal TV programmes automatically when playing back and recording.
ON	The VCR always plays back and records in the mode compatible with 16:9 wide screen. Set if the VCR cannot detect wide TV programmes with "AUTO" set.
OFF	Set if you do not use a wide TV.
- On completion, press MENU twice to exit the menu.

Selecting the Colour Mode

Before recording or playing back a cassette, you can select the required system standard.

Otherwise, the system automatically selects the reception standard when you select **AUTO**.

- When playing back a cassette, the standard is automatically selected by the VCR.
- When you playback an NTSC-recorded tape on this VCR make a setting on the colour system according to your TV. If your TV is a PAL system only TV, set NTPB. If your TV is Multi System TV (NTSC 4.43 compatible), set NT4.43 and you can record NT4.43.

- Press MENU on the remote control.
Result: The programming menu is displayed.
- Press the corresponding \triangle or ∇ buttons, until the cursor is placed in front of the **USER SET** option.
- Press the \triangleright button to select this option.
Result: The **USER SET** menu is displayed.
- Press the corresponding \triangle or ∇ buttons, until the cursor is placed in front of the **COLOUR SYSTEM** option.
- Press the \triangleright button to select **AUTO** \rightarrow **PAL** \rightarrow **B/W**.

AUTO	When playing back a cassette, the system standard is automatically selected by the VCR.
B/W	Black and White
- On completion, press MENU twice to exit the menu.

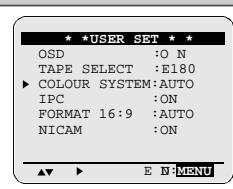

Selecting the Audio Output Mode

GB

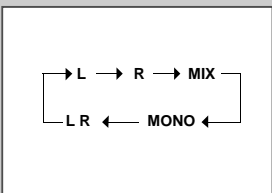
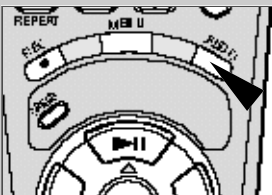

You can select the mode in which the sound is reproduced on the loudspeakers and AV outputs. The following options are available.

Option	Description
L	Used to listen to the sound on the left Hi-Fi channel.
R	Used to listen to the sound on the right Hi-Fi channel.
MIX	Used to listen to the mixed sound of the Hi-Fi and normal channels.
MONO	Used to listen to the sound on the normal mono channel.
L R	Used to listen to Hi-Fi stereo sound on the left and right channels. <ul style="list-style-type: none"> ➤ When playing back tapes recorded in Hi-Fi, the sound switches to Hi-Fi after five seconds of Mono.

To select the sound mode, simply press the AUDIO button on the remote control until the required option is displayed.

Playing a Cassette in Slow Motion

GB

You can play a cassette in slow motion.

- No sound is heard when playing back a cassette in slow motion.

- 1 Press:
 - ◆ **▶||** to start playing the cassette
 - ◆ **SLOW** (⓪ → Ⓛ) as many times as required to decrease or increase the speed respectively
 - ◆ To return to the normal speed, press the **▶||** button twice.
- 2 When playing back in slow motion, picture interference may occur. Press the **TRK** (↶ or ↷) buttons to minimize this effect.

- When you have been using the Slow Motion function for more than about five minutes, the VCR will automatically play to protect the:
 - ◆ Cassette
 - ◆ Video heads

- Vertical stability: When playing back slow motion, interference may be seen on the screen. Press the **V-LOCK** (Ⓛ → Ⓢ) buttons to minimize this effect.

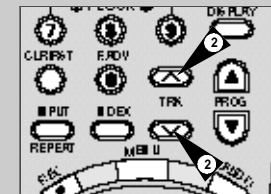
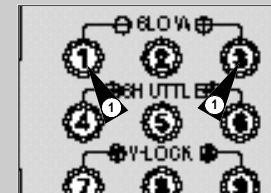

Playing a Sequence Frame by Frame

GB

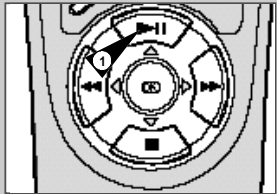

You can:

- ◆ Stop the cassette at a given frame (image)
- ◆ Advance one frame at a time

➤ No sound is heard when playing back frame by frame.

- 1 Press:
 - ◆ **▶▶** to start playing the cassette
 - ◆ **▶▶** to stop the tape at a given frame
 - ◆ F.ADV (Ⓜ) to advance frame by frame

- 2 To return to normal playback, press **▶▶**.

➤ When you have been using the Frame-by-Frame function for more than about five minutes, the VCR will automatically play to protect the cassette and video heads.

➤ Vertical stability: When playing back frame by frame, interference may be seen on the screen. Press the V-LOCK (Ⓜ) buttons to minimize this effect.

Playing a Sequence at Variable Speeds

You can vary the playback speed using the Shuttle function (up to nine times the normal speed).

Example: You wish to analyze a sportsperson's technique, movement by movement.

The Shuttle function is available on the Remote control

➤ No sound is heard when playing a sequence at variable speeds.

- 1 Press:
 - ◆ **▶▶** during playback
 - ◆ SHUTTLE (Ⓜ) to play the cassette backwards
 - ◆ SHUTTLE (Ⓜ) to play the cassette forwards
- 2 Each time you press a SHUTTLE (Ⓜ) button, the speed is changed as shown in the following illustration.

REVERSE PLAY X9	REVERSE PLAY X7	REVERSE PLAY X3	STILL	SLOW MOTION X1/10	SLOW MOTION X1/5	PLAY	PLAY X3	PLAY X7	PLAY X9
-----------------------	-----------------------	-----------------------	-------	-------------------------	------------------------	------	------------	------------	------------

34

Searching for a Specific Sequence

Each time you record a cassette on this VCR, an "index" is automatically marked on the tape when recording starts.

The Search function allows you to fast-forward or rewind to a specific index and start playback from that point. Depending on the direction selected, the indexes are numbered as follows:

↓				
etc.	Prev Seq.	Seq. being played	Next Seq.	etc.
	2	1	1	2

➤ This VCR uses a standard indexing system (VISS). As a result, it will recognize any indexes marked by other VCRs using the same system and vice versa.

- 1 To search for a specific index, press INDEX.
- 2 Enter the number of the index to be found using the numeric buttons.
 - When entering a single digit number, do not forget to precede it with a zero.
 - Example:** 02.
 - Result:** The index number is displayed.
- 3 Select the direction in which the VCR is to search:
 - ◆ **◀◀** to search backwards
 - ◆ **▶▶** to search forwards
 - Result:** When the index is found, cassette playback starts.

GB

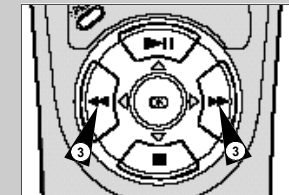
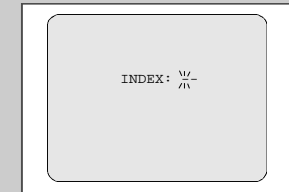

35

Auto Repeat Play

GB

```

* * M E N U * *
TIMER PROGRAMMING
USER SET
INSTALLATION
CLOCK SET
▶ EASY OPERATION
END:MENU
  
```

```

* * EASY OPERATION * *
AUTO POWER OFF :OFF
▶ REPEAT PLAY :OFF
NO. OF
INTERVAL REPEAT : 5
END:MENU
  
```

Interval Repeat Play

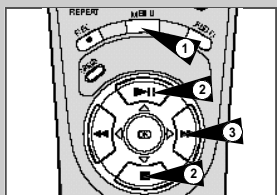

```

* * M E N U * *
TIMER PROGRAMMING
USER SET
INSTALLATION
CLOCK SET
▶ EASY OPERATION
END:MENU
  
```

```

* * EASY OPERATION * *
AUTO POWER OFF :OFF
REPEAT PLAY :OFF
▶ NO. OF
INTERVAL REPEAT : 5
END:MENU
  
```

36

You can set repeat play to repeat the tape continuously from beginning to end.

- Press MENU on the remote control.
Result: The programming menu is displayed.
- Press the corresponding Δ or ∇ buttons, until the cursor is placed in front of the **EASY OPERATION** option.
- Press the \blacktriangleright button to select this option.
Result: The **EASY OPERATION** menu is displayed.
- Press the corresponding Δ or ∇ buttons, until the cursor is placed in front of the **REPEAT PLAY** option.
- To... **Press \blacktriangleleft or \blacktriangleright , until...**
Repeat play **ON** is displayed.
Do not wish to repeat play **OFF** is displayed.
- On completion, press MENU twice to exit the menu.

You can set interval repeat play to repeat the cassette several times for special interval.

- Press MENU on the remote control.
Result: The programming menu is displayed.
- Press the corresponding Δ or ∇ buttons, until the cursor is placed in front of the **EASY OPERATION** option.
- Press the \blacktriangleright button to select this option.
Result: The **EASY OPERATION** menu is displayed.
- Press the corresponding Δ or ∇ buttons, until the cursor is placed in front of the **NO. OF INTERVAL REPEAT** option.
- To... **Press \blacktriangleright , until...**
Interval repeat play 5, 10, 15 is displayed.
(choose repeat time 5 times, 10 times, 15 times)
Cancel interval repeat play **OFF** is displayed.
- On completion, press MENU twice to exit the menu.
- To select interval during playback, press the INPUT/REPEAT button at the desired start point.
Result: "INTERVAL REPEAT SETTING" is displayed.
Press the INPUT/REPEAT button one more time at the desired end point.
Result: The tape is automatically rewound to the start point.
"INTERVAL REPEAT" is displayed.

Using the Tape Counter

GB

The tape counter:

- Indicates the elapsed time in the play and record modes (hours, minutes and seconds)
- Is reset when a cassette is inserted in the VCR
- Allows you to find the beginning of a sequence easily

If the remaining time is to be calculated correctly, you must indicate the type of cassette being used.

- Insert a cassette in your VCR.
- To set the tape counter to zero at the beginning of a sequence:
 - Press DISPLAY twice to display the counter
 - Press CLR/RST when you want to set the tape counter to zero
- To fast-forward or rewind to the sequence at which the counter was set to zero, simply press \ll or \gg .
Result: The VCR stops automatically when the counter reaches zero.

Some VCR information, such as the counter, can be displayed on the television screen (unless you have deactivated the OSD mode; refer to page 16).

Press DISPLAY:

- Once to display the current function, programme number, recording speed, date, time and counter
- Twice to display the counter only
- Three times to display the time remaining on the cassette
- Four times to clear the display

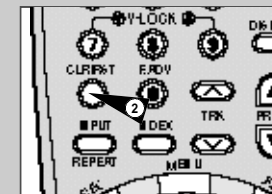
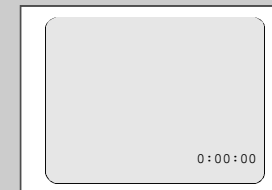



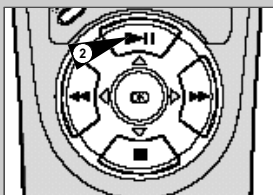

37

Using the Assemble Edit Function



This function allows you to start a new recording at a specific position on the cassette while maintaining a very smooth scene change.

- 1 Insert the cassette to be edited in your VCR.
- 2 Press the **▶||** button to start playback.
- 3 When you reach the position from which you wish to start the new recording, press the **▶||** button.
- 4 Press the F.ADV () button again as often as necessary to advance frame by frame, until the exact recording position is located.
- 5 While the VCR is in still mode, hold the REC button () down for a while to activate the Assemble Edit function.
Result: Record symbol flashes in the display.
- 6 Select the source from which you wish to record by pressing:
 - ◆ The PROG ( or ) buttons for television channels
 - ◆ The INPUT button for the AV1 or AV2 input sources
- 7 Press the **▶||** button to start recording.
- 8 When you have finished recording, press **■**.

Recording from Another VCR or Camcorder

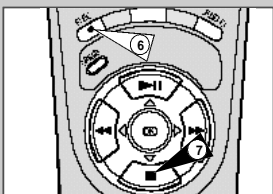
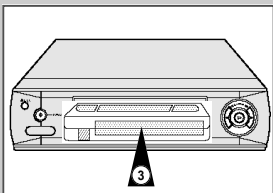

You can copy a cassette to your VCR from another video source, such as another VCR or a camcorder.

 It is an infringement of copyright laws to copy prerecorded cassettes or to re-record them in any form without the permission of the owners of the corresponding copyright.

- 1 Connect the VCR, from which the cassette is to be copied, to the appropriate SCART audio and video input connectors on the rear of your VCR, as indicated on page 12.
- 2 Insert a blank cassette in your VCR.
- 3 Insert the pre-recorded cassette in the other video source (VCR or camcorder).
- 4 Press the INPUT button to select the appropriate input on your VCR:
 - ◆ AV1 or AV2 for the SCART input
- 5 Start playing back the cassette to be copied.
- 6 Hold REC () down for a while to start recording on your VCR.
- 7 When you have finished recording, press **■** on both VCRs.

 If you wish to view the cassette being copied:

- ◆ Your VCR must be connected as usual to the television (see page 12 for further details)

38

Auto Power Off

The Auto Power Off feature automatically turns off your VCR if no signal is received and you do not press any button for the selected time.

- 1 Press MENU on the remote control.
Result: The programming menu is displayed.
- 2 Press the corresponding **▲** or **▼** buttons, until the cursor is placed in front of the **EASY OPERATION** option.
- 3 Press the **▶** button to select this option.
Result: The **EASY OPERATION** menu is displayed.
- 4 Press the corresponding **▲** or **▼** buttons, until the cursor is placed in front of the **AUTO POWER OFF** option.
- 5 Press the **▶** button, until you select the time of Auto Power off interval.
OFF → 2HOUR → 3HOUR
- 6 On completion, press MENU twice to exit the menu.

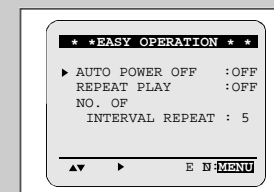
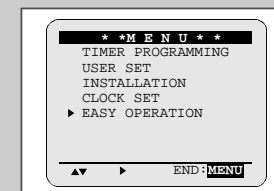
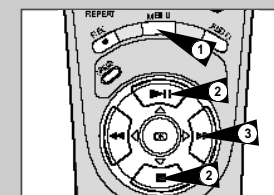

Resetting Your VCR

If you find that your VCR is not operating correctly, or no indications appear in the display, you can reset it.

- 1 Press the RESET button on the rear panel with a pen or pencil, to reset the VCR.
Result: All preset data will be erased and will need to be reprogrammed.
- 2 If the problem is not solved after you have reset the VCR, refer to page 41 for a list of simple checks to be performed before contacting the after-sales service.

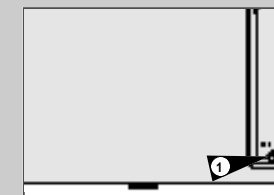

Child door Lock System

With this mechanism you can prevent children from harming themselves or the VCR. It stops fingers and small articles from entering your VCR.

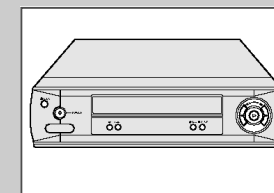

39

Technical Specifications

Design and specifications are subject to change without notice.

Format	VHS PAL standard
Heads	Video: 4 rotary heads Hi-Fi audio: 2 rotary heads Audio/Control: 1 stationary head Erase: 1 full track erase head
Receiving channel	UHF 21-69CH
Television system	STANDARD I-NICAM STEREO
Luminance	FM azimuth recording
Colour system	PAL: Down converted subcarrier phase shifted direct recording NTSC PB on PAL TV
Tape speed	SP 23.39 mm/sec LP 11.69 mm/sec
Recording/playback time	SP 3 hours (E-180 Tape) LP 6 hours (E-180 Tape)
REW time	About 100 sec in REW with E-180
VIDEO	
Input	0.5 to 2.0 Vp-p; 75 ohm unbalanced
Output	1.0 ± 0.2 Vp-p; 75 ohm unbalanced
Signal-to-noise ratio	Better than 43 dB (SP)
Horizontal resolution	More than 240 lines (SP)
AUDIO	
Input	-8 dBm, 47 Kohm unbalanced
Output	-8 ± 3 dBm, 1 Kohm unbalanced
Wow and flutter (WTD)	0.4% max (SP)
Signal-to-noise ratio	68 dB min (IHF A filter)
Frequency response	20Hz - 20kHz
Power requirement	230V (AC 50-60 Hz)
Power consumption	Approx. 17 watts
Operation temperature	41°F-104°F (5°C-40°C)
Operation humidity	10%-75%
Weight	3.3 Kg (net)
Dimensions (WxHxD)	360 x 285 x 94 mm

Problems and Solutions

Before contacting the Samsung after-sales service, perform the following simple checks.

Problem	Explanation/Solution
No power	<ul style="list-style-type: none"> ◆ Check that the power plug is connected to a wall outlet. ◆ Have you pressed the POWER button?
You cannot insert a video cassette	<ul style="list-style-type: none"> ◆ A video cassette can only be inserted with the window side up and the safety tab facing you.
The television programme was not recorded	<ul style="list-style-type: none"> ◆ Check the VCR aerial connections. ◆ Is the VCR tuner properly set? ◆ Check if the safety tab is intact on the cassette.
Timer recording was unsuccessful	<ul style="list-style-type: none"> ◆ Was the POWER button pressed to activate the timer? ◆ Re-check the recording start/stop time settings. ◆ If there was a power failure or interruption during timer recording, the recording will have been cancelled.
No playback picture or the picture is distorted	<ul style="list-style-type: none"> ◆ Check to see if you are using a prerecorded tape.
You cannot see normal broadcasts	<ul style="list-style-type: none"> ◆ Check the TUNER/EXTERNAL setting. It should be on TUNER. ◆ Check the TV/VCR aerial connections.
Noise bars or streaks on playback	<ul style="list-style-type: none"> ◆ Press the TRK (↶ or ↷) buttons to minimize this effect.
When the PAUSE button is pressed during playback, the still picture has severe "noise bars" streaks	<ul style="list-style-type: none"> ◆ A still picture may have "noise bars", depending on the condition of the tape. Press the TRK (↶ or ↷) buttons during SLOW motion to minimize this effect.
Incorrect operations or no display	<ul style="list-style-type: none"> ◆ Use a pencil to press the RESET button and reinitialize the VCR. All preset data is lost.
Video Head Cleaning	<ul style="list-style-type: none"> ◆ If poor pictures appear on a variety of cassettes, the video heads may need cleaning. This is not a common problem and unless it appears, the heads should not be cleaned. When cleaning the video heads, read all instructions provided with the head cleaning cassette. Incorrect head cleaning can permanently damage the video heads.
If when tuning in your TV to the VCR test pattern your TV does not find the test pattern or the pattern when found suffers from interference, it may be due to the VCR output channel clashing with the normal TV transmissions in your area. To prevent this you will need to change the VCR output channel in the following way	<ol style="list-style-type: none"> 1. Remove the aerial input plug from the socket marked (aerial symbol) on the rear of the VCR. 2. Carry out the instructions "Tuning Your Television for the VCR" (see page 14). 3. Carry out the instructions "Setting the VCR output Channel" (see page 16), move the channel number several channels down from the original setting. (example: from 60 to 57). 4. Replace the aerial plug into the socket marked (aerial symbol) on the rear of the VCR. 5. Re-tune your TV to the VCR again by following instructions "Tuning Your Television for the VCR" (page 14). 6. If the problem still exists repeat steps 1 to 5 moving several more channels away from the original setting.

If you are unable to solve the problem after reading the above instructions, note:

- ◆ *The model and serial number on the rear of your VCR*
- ◆ *The warranty information*
- ◆ *A clear description of the problem*

Then contact your nearest SAMSUNG after-sales service.

SAMSUNG ELECTRONICS (UK) LTD
AUTHORISED SERVICE CENTERS

In the event of warranty service being required, please contact your retailer first. If they cannot provide service, please contact your nearest service centre listed below. Service facilities are return to base, however some agents may provide an in-home service (there may be a cost for call out). Please refer to your warranty card or retailer for terms and conditions of the warranty.

AVON BRISTOL GOGGLEBOX TV TEL: 01275 838083	ESSEX WICKFORD CENTRAL SERVICE TEL: 01268 766333	LONDON WILLESDEN ATLANTIC ELECTRIC TEL: 0181 451 6155	WEST MIDLANDS DUDLEY J S STOREY ELECTRICAL TEL: 01384 456608
BERKSHIRE READING A & W SOUND & VISION TEL: 01734 872000	MID GLAMORGAN BRIDGEND BRIDGEND SERVICE TEL: 01656 663463	MANCHESTER ASHTON UNDER LYNE VIDEOTECH UK TEL: 0161 308 4092	WALSALL BEAVER ELECTRONICS TEL: 01922 725554
MAIDENHEAD J F ASSOCIATES TEL: 01628 25709	GLoucestershire TEWKESBURY SWITCH ELECTRONICS TEL: 01684 850063	NORTHENDEN G H SUMNER LTD TEL: 0161 998 2705	WARLEY MERRIVALE TV SVCS TEL: 0121 544 6273/6350
WARGRAVE J F ASSOCIATES TEL: 01734 401525	WESTON-SUB-EDGE PROFESSIONAL ELECTRONIC TEL: 01396 841773	MERSEYSIDE ELLESMERE PORT H & H VIDEO & TV TEL: 0151 357 1011	WILTSHIRE SWINDON COLORITE TV LTD TEL: 01793 641038
CAMBRIDGESHIRE DRY DRAYTON DRAYTON ELECTRONICS TEL: 01954 211330	HAMPSHIRE FAREHAM SOUND & VISION TEL: 01329 286551	LIVERPOOL P & A AUDIO VIDEO LTD TEL: 0151 924 7287	WORCESTERSHIRE WORCESTER THE HI FI CAR RADIO REPAIR TEL: 01905 26823
PETERBOROUGH DEEPING TV SVCS TEL: 01778 343631	FARNBOROUGH ICTV TEL: 01252 510118	MIDDLESEX HAYES A & A REPAIRS TEL: 0181 561 2900/4104	SOUTH YORKSHIRE SHEFFIELD GRAPHIC ELECTRONIC SVCS TEL: 0114 256 2791
CHESHIRE CHESTER H & H VIDEO & TV TEL: 01244 379579	PORTSMOUTH ICTV TEL: 01705 653654	NORFOLK AYLESHAM CORTONS ELECTRICAL TEL: 01263 733391	BARNLEY ALTRA TEL: 01226 207434
WARRINGTON W L ELECTRONICS TEL: 01925 764387	SOUTHAMPTON OLYMPIC TV & AUDIO TEL: 01703 703401	WATTON JULIAN HORN TEL: 01953 881440	NORTH YORKSHIRE YORK DBS SERVICE CENTRE TEL: 01904 789789
CORNWALL BUDE H B H WOOLACOTTS TEL: 01288 352289	HEREFORD HEREFORD J P MICRO SVCS TEL: 01432 356353	NORTHAMPTONSHIRE KETTERING INTEGRATED SVCS TEL: 01536 516475	WEST YORKSHIRE BRADFORD GRAPHICK ELECTRON TEL: 01274 862257
LAUNGESTON H B H WOOLACOTTS TEL: 01566 772096	HERTFORDSHIRE BALDOCK TECHNICAL REPAIR SVC TEL: 01462 491144	OXFORDSHIRE BANBURY HITECH TEL: 01295 267415	HUDDERSFIELD GRAPHIC ELECTRONICS TEL: 01484 451045
NEWQUAY GREENBANK ELECTRONICS TEL: 01637 880576	MARKYATE TELETECH SVCS TEL: 01582 841862	BOTLEY SPECTRUM ELECTRON TEL: 01865 250199	ILKLEY R BEAUMONT TEL: 01943 607021
WADEBRIDGE H B H WOOLACOTTS TEL: 01208 816155	NORTH HUMBERSIDE GOOLE HEADLAND ELECTRCRS TEL: 01977 661223	SHROPSHIRE TELFORD W OWEN TEL: 01952 613818	CHANNEL ISLANDS GUERNSEY TELESKILL LTD TEL: 01481 56508
CUMBRIA BARROW IN FURNESS KENNETH GARDNER TEL: 01229 821202	SOUTH HUMBERSIDE GRIMSBY RAYNERS SUPERSTORE TEL: 01472 358766	SOMERSET TAUNTON ARMTECH ELECTRONICS TEL: 01823 279401	JERSEY ALTERNATIVE ELECT TEL: 01534 68277
SEARLE AUDIO PENRITH CANNAN & BROWN TEL: 01768 864829	KENT CANTERBURY BARRETTS OF CANTERBURY TEL: 01227 766582	YEDVIL M J THOMAS TEL: 01935 477255	ISLE OF WIGHT AUDIO VISION SVCS TEL: 01983 752023
DEVON HOLSWORTHY H B H WOOLACOTTS TEL: 01409 253280	DARTFORD BUDGET REPAIR CENTRE TEL: 01322 227668	STAFFORDSHIRE STOKE ON TRENT TELEFAULTS (S.O.T.) LTD TEL: 01782 813757	NORTHERN IRELAND CO ARMAGH CRAIGAVON TV SVCS TEL: 0762 326119/322505
NEWTON ABBOT TELLI-SCOPE ELECTRONICS TEL: 01626 63907	MAIDSTONE AVERY ELECTRONICS TEL: 01622 682138	SUFFOLK IPSWICH GGN LTD TEL: 01473 744300	EIRE CO CORK TYAE REPAIRS TEL: 00353 21 273457
PLYMOUTH ARGYLE TV & VIDEO TEL: 01752 779933	LANCASHIRE BLACKPOOL KENNETH GARDNER TEL: 01253 824047	SURREY WALLINGTON SERVICECARE TEL: 0181 669 1145	GRAMPIANS FRASERBURGH RODGERS ELECTRICAL TEL: 01346 518540
CTV ELECTRONICS TEL: 01752 350990	LANGASTER KENNETH GARDNER TEL: 01524 64468	ROCHDALE CTV SERVICES TEL: 01706 654983	HIGHLANDS ULLAPOOL R & R ELECTRONICS TEL: 01854 612608
DORSET BOURNEMOUTH M & G ELECTRONICS TEL: 01202 523771	LEICESTERSHIRE LEICESTER SOUND & VISION CENTRE TEL: 01162 730444	HORLEY D K AUDIO VISUAL SVCS TEL: 01293 786459	LOTHIAN EDINBURGH RETEC AUDIO & VISUAL TEL: 0131 478 7779
DURHAM DURHAM LEE TECH SVCS TEL: 0191 371 1300	LINCOLNSHIRE BRANSTON STUART WALLACE TEL: 01522 791496	EAST SUSSEX SEAFORD CLEARVIEW RENTAL & RELAY TEL: 01323 898989	STRATHCLYDE GLASGOW DSC ELECTRONICS TEL: 0141 941 3711
DARLINGTON GAZE ELECTRONICS TEL: 01325 482344	LONDON HIGH HOLBORN BERRYS OF HOLBORN TEL: 0171 405 1157	EASTBOURNE STARTEC SVCS TEL: 01323 412012	TAYSIDE DUNDEE ANCRUM ELECTRONICS TEL: 01382 454511
DYFED CARMARTHEN ADVANCE CONSUMER TEL: 01267 236143	LONDON WEST EALING BABBER ELECTRONICS TEL: 0181 578 6315	TYNE & WEAR NEWCASTLE UPON TYNE M SINGH RADIO & TV TEL: 0191 226 0446	
ST CLEARS BEN EVANS & SON TEL: 01994 231015		WEST MIDLANDS COVENTRY D & J HENRY TEL: 01203 431393	

THIS APPLIANCE IS DISTRIBUTED BY

