

**SAMSUNG**

# CUPTOR CU MICROUNDRE

## Manual de utilizare

**MW87W**

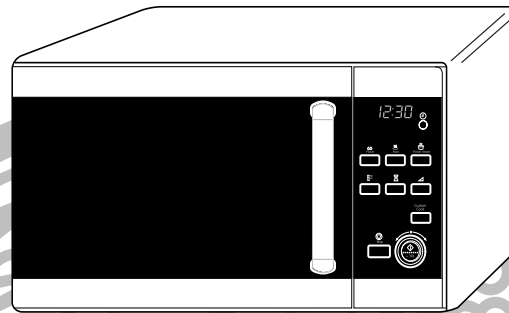

Cuptor .....	2
Accesorii.....	2
Panou de control .....	2
Folosirea manualului de instructiuni .....	3
Masuri de siguranta .....	3
Instalarea cuptorului cu microundre .....	5
Setarea ceasului .....	5
Ce trebuie facut atunci cand cuptorul nu functioneaza corect.....	6
Preparare/ Reincalzire .....	6
Nivele putere.....	7
Oprirea prepararii.....	7
Ajustarea timpului de preparare.....	7
Folosirea functiunii Auto Reincalzire.....	8
Setarile functiunii Auto Reincalzire.....	8
Folosirea functiunii de Auto Dezghetare.....	9
Setarile functiunii Auto Dezghetare .....	9
Folosirea functiunii Power Steam.....	10
Funciunea de deodorizare.....	11
Setarea timpului de asteptare.....	11
Folosirea functiunii Custom Cook.....	11
Oprirea semnalului sonor.....	12
Blocarea cuptorului cu microundre.....	12
Ghid accesorii de preparare .....	13
Curatarea cuptorului cu microundre.....	14
Depozitare si reparatii cuptor cu microundre.....	14
Specificatii tehnice .....	15

## Cuptor

RO

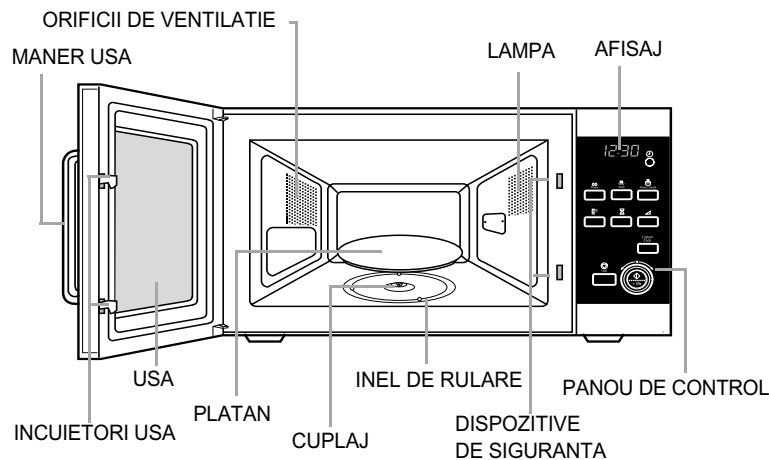

## Accesorii

*In functie de modelul pe care l-ati achizitionat, vi se vor livra cateva accesorii, care pot fi folosite in diferite moduri.*

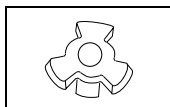

1. **Cuplaj**, deja plasat pe axul motorului situat la baza cuptorului.  
**Scop** : Cuplajul rotește platanul.

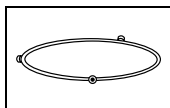

2. **Inel de rulare**, care se plaseaza in centrul cuptorului.  
**Scop** : Inelul de rulare sustine platanul.

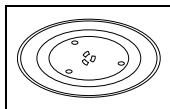

3. **Platan**, care se plaseaza pe inelul de rulare si centrul fixandu-se la cuplaj.  
**Scop** : Platanul servește ca suprafața principală de preparare; poate fi scos cu ușurință, pentru curățare.



4. **Dispozitiv preparare cu aburi Power steam**, vedeți pagina 10.  
**Scop** : Folosiți dispozitivul de preparare cu aburi, confecționat din material plastic.



Nu folosiți niciodată cuptorul cu microunde fără inelul de rulare și platan.

## Panou de control

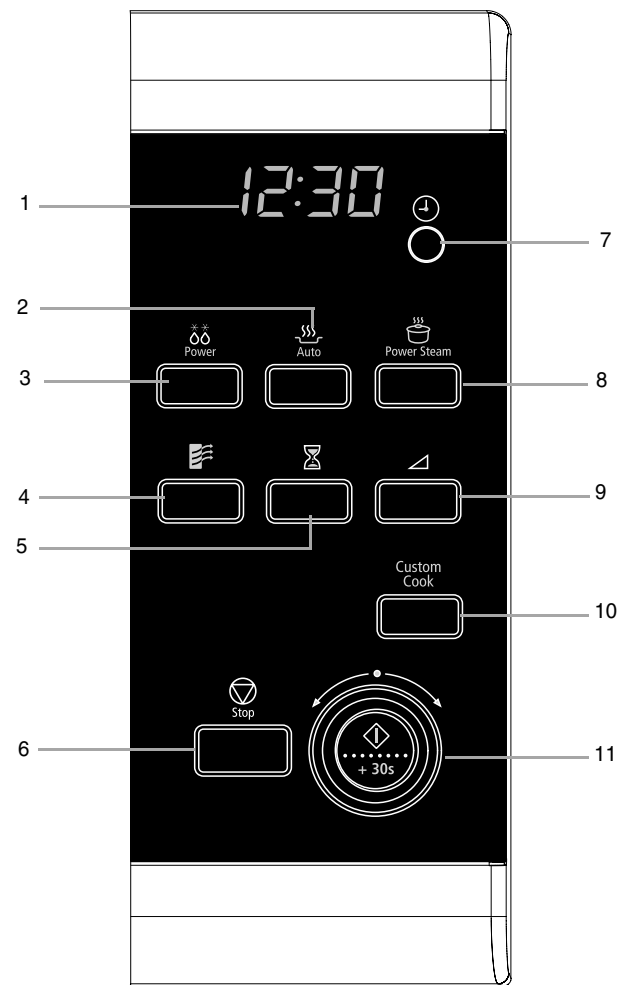

- |                               |   |
|-------------------------------|---|
| 1. AFISAJ                     | 7. SETARE CEAS  |
| 2. SELECTARE AUTO REINCALZIRE | 8. SELECTARE POWER STEAM  |
| 3. BUTON DEZGHETARE AUTOMATA  | 9. SETARE NIVEL PUTERE  |
| 4. BUTON DEODORIZARE          | 10. BUTON CUSTOM COOK   |
| 5. SETARE TIMP AȘTEPTARE      | 11. BUTON START SETARE (timp de preparare, greutate și porție de servire) |
| 6. BUTON STOP ANULARE         |   |

## Folosirea manualului de instructiuni

Tocmai ati achizitionat un cuptor cu microunde SAMSUNG. Manualul de instructiuni cuprinde informatii importante referitoare la prepararea alimentelor cu ajutorul cuptorului cu microunde:

- Masuri de siguranta
- Accesorii potrivite si vesela de preparare
- Sfaturi utile de preparare

La inceputul manualului veti gasi ilustratii asupra cuptorului, si in special ale panoului de comanda, astfel ca veti recunoaste butoanele mult mai usor.

Procedurile pas cu pas folosesc trei simboluri diferite:



Important



Nota

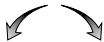

Rotiti

### PRECAUTII PENTRU EVITAREA UNEI POSIBILE EXPUNERI EXCESIVE LA ENERGIA MICROUNDDELOR

Cititi cu atentie urmatoarele masuri de siguranta; in caz contrar poate avea loc o expunere la energia microundelor, ce poate avea umari neplacute.

- (a) In nici un caz, nu trebuie sa incercati sa folositi cuptorul cu microunde cu usa deschisa, sa modificati incuietorile de siguranta ale usii sau sa introduceti obiecte un gaurile incuietorilor de siguranta.
- (b) Nu plasati nici un obiect intre usa cuptorului si partea frontala si nu permiteti resturilor alimentare sa se acumuleze pe suprafetele de etansare. Asigurati-va ca usa si suprafetele de etansare sunt curate, stergandu-le dupa folosire cu o carpa umeda si apoi cu o carpa moale si uscata.
- (c) Nu folositi cuptorul cu microunde, daca acesta este defect. Apelati la ajutorul unui tehnician service, instruit de catre producator.  
Este foarte important ca usa cuptorului sa se inchida corect si sa nu existe nici o defectiune a:
  - (1) Usii, incuietorilor acesteia si a suprafetelor de etansare
  - (2) Balamalelor usii (rupte sau slabite)
  - (3) Cablului de alimentare
- (d) Cuptorul cu microunde nu trebuie modificat sau reparat, decat de catre un tehnician service calificat corespunzator si instruit de catre producator.

## Masuri de siguranta

Masuri de siguranta importante.

Cititi cu atentie si pastrati manualul pentru o folosire ulterioara.

Inainte de a prepara alimente sau lichide in cuptorul cu microunde, va rugam sa verificati daca au fost luate urmatoarele masuri de siguranta.

1. **Nu folositi nici un vas metalic in interiorul cuptorului cu microunde.**
  - Containere metalice
  - Vesela cu ornamentatii de aur sau argint
  - Frigarui , furculite, etc.

Motiv : Pot apare scantei sau arc electric, care vor deteriora cuptorul.
2. **Nu incalziti:**
  - Sticle, borcane, containere etanse sau sigilate in vid.  
Ex: Borcane cu alimente pentru copii.
  - Alimente sigilate ermetic.  
Ex: Oua, rosii.

Motiv : Presiunea va creste la incalzire si poate duce la explozia acestora.  
Sfat : Scoateti capacele si intepati sacii sau pungile, etc.
3. **Nu puneti in functionare cuptorul cu microunde, atunci cand acesta este gol.**

Motiv : Peretii cuptorului se pot deteriora.  
Sfat : Lasati intotdeauna un pahar cu apa in interiorul cuptorului.  
Apa va absoarbe microundele in cazul unei porniri accidentale a cuptorului cu microunde, atunci cand acesta este gol.
4. **Nu acoperiti orificiile de ventilatie cu carpe sau hartie.**

Motiv : Carpele sau hartia pot lua foc datorita aerului cald evacuat din cuptor.
5. **Folositi intotdeauna manusi atunci cand scoateti alimente sau vesela din cuptor.**

Motiv : Unele vase absorb microundele si caldura este transferata intotdeauna de la aliment la vas. De aceea, vasele sunt fierbinti.
6. **Nu atingeti elementul de incalzire si peretii interiori ai cuptorului cu microunde.**

Motiv : Acesti pereti ar putea sa fie destul de fierbinti incat sa va arda chiar si dupa ce prepararea a luat sfarsit. Nu permiteti ca materiale inflamabile sa intre in contact cu aria interioara a cuptorului. Lasati intai cuptorul sa se raceasca.
7. Pentru a reduce riscul unui incendiu in cavitatea cuptorului:
  - Nu depozitati materiale inflamabile in interiorul cuptorului cu microunde.
  - Indepartati sigiliile metalice ale ambalajelor de plastic sau hartie, ale alimentelor.
  - Nu folositi cuptorul pentru a usca ziare.
  - Daca observati ca iese fum, lasati usa cuptorului inchisa si opriti aparatul sau deconectati-l de la sursa de alimentare.

RO

## Masuri de siguranta (continuare)

RO

8. Aveti o grija deosebita atunci cand, incalziti lichide sau alimente pentru copii.
- Lasati intotdeauna un timp de asteptare de 20 de secunde, dupa ce cuptorul a fost oprit, pentru a permite echilibrarea temperaturii.
  - Amestecati pe durata incalzirii, daca este necesar, si intotdeauna dupa incalzire.
  - Aveti grija atunci cand luati vasul din cuptor, dupa incalzire. In cazul in care, vasul este prea fierbinte, va puteti arde.
  - Exista risul unei eruptii intarziate a fierberii.
  - Pentru a preveni fierberea intarziata si o posibila oparire, ar trebui sa introduceti o lingurita de plastic sau o bagheta de sticla in lichide si amestecati inainte, in timpul si dupa preparare.
- Motiv : Pe durata incalzirii lichidelor, punctul de fierbere poate fi intarziat; aceasta inseamna ca poate apare o eruptie a fierberii imediat dupa ce recipientul a fost scos din cuptor. In acest caz, exista pericolul oparirii.
- In caz de oparire, urmati instructiunile de prim ajutor urmatoare:
    - \* Introduceti zona oparita in apa rece, pentru cel putin 10 minute.
    - \* Acoperiti cu o haina curata si uscata.
    - \* Nu aplicati nici un fel de creme, uleiuri sau lotiuni.
  - Nu umpleti niciodata complet vasul si alegeti un vas care este mai larg la gura decat la baza, pentru a preveni scurgerea la fierbere a lichidului. Sticlele cu gat subtire pot de asemenea exploda, daca sunt supraincalzite.
  - Verificati intotdeauna temperatura alimentelor pentru copii si a laptelui, inainte de servire.
  - Nu incalziti niciodata o sticla pentru copii cu biberonul atasat; poate exploda la supraincalzire.
9. Aveti grija sa nu deteriorati cablul de alimentare.
- Nu introduceti cablul de alimentare sau stecherul in apa si tineti cablul de alimentare departe de suprafetele incalzite.
  - Nu folositi acest aparat daca, cablul de alimentare sau stecherul este defect.
10. Atunci cand deschideti usa cuptorului, stati la o lungime de brat de acesta.
- Motiv : Aerul cald sau aburul eliberat pot provoca oparirea.
11. Pastrati curat interiorul cuptorului cu microunde .
- Motiv : Particulele de alimente sau petele de ulei de pe peretii sau baza cuptorului, pot deteriora vopseaua si reduce eficienta aparatului.
12. Un "ciic" poate fi observat pe durata functionarii, in special, atunci cand cuptorul se afla in modul de dezghetare.
- Motiv : Atunci cand puterea de iesire se schimba, este posibil sa auziti acest sunet.
13. Daca cuptorul cu microunde functioneaza gol, alimentarea cu energie se va opri automat, pentru siguranta. Puteti folosi din nou cuptorul, in mod normal, dupa o perioada de 30 de minute.

### MASURI DE SIGURANTA IMPORTANTE

Pe durata prepararii, ar trebui sa va uitati din cand in cand in interiorul cuptorului, atunci cand alimentele sunt incalzite sau preparate in recipiente de unica folosinta din plastic, hartie sau alt material combustibil.

### IMPORTANT

Nu trebuie permis copiilor sa foloseasca sau sa se joace la cuptorul cu microunde. Nu trebuie lasati copii nesupravegati in apropierea cuptorului, atunci cand acesta este in functiune. Obiecte care pot trezi interesul copiilor, nu trebuie depozitate sau ascunse pe cuptorul cu microunde.

### AVERTIZARE:

Daca usa sau garniturile de etansare ale acesteia sunt defecte, nu folositi cuptorul pana la repararea de catre personal autorizat.

### AVERTIZARE:

Operatiunile de service sau reparatii, ce implica demontarea capacului de protectie impotriva expunerii la energia microundelor, trebuie executate numai de catre personal calificat.

### AVERTIZARE:

Lichidele sau alte tipuri de alimente nu trebuie incalzite in recipiente etanse, deoarece acestea pot exploda.

### AVERTIZARE:

Permiteti copiilor sa foloseasca cuptorul cu microunde fara supraveghere, numai atunci cand acestia au fost corespunzator instruiti, astfel incat sa fie capabili de a utiliza aparatul in siguranta si de a intelege riscurile unei utilizari incorecte.

## Instalarea cuptorului cu microunde

Asezati cuptorul cu microunde pe o suprafata neteda, dreapta si destul de rezistenta incat sa suporte greutatea acestuia.

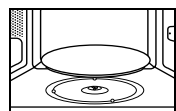
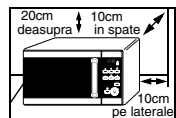

1. Atunci cand instalati cuptorul cu microunde, asigurati-va ca exista o ventilare adecvata, lasand un spatiu de cel putin 10 cm in spate si in laterale, un spatiu de 20 cm deasupra acestuia si un spatiu de 85 cm de la podea la cuptor.
2. Scoateti toate materialele de ambalare din interiorul cuptorului. Instalati inelul de rulare si platanul. Verificati daca platanul se invarte corect.
3. Acest cuptor cu microunde trebuie pozitionat astfel incat stecherul cablului de alimentare sa fie usor accesibil.

- Nu blocati niciodata orificiile de ventilatie, deoarece cuptorul se va supraincalzi si se va opri automat. Va ramane inoperabil pana ce se raceste suficient.
- Pentru siguranta dumneavoastra, conectati cablul de alimentare la o priza cu 3-pini, 230 Volti, 50Hz, AC si cu impamantare. Daca, este deteriorat acesta trebuie inlocuit cu un cablu special (I-SHENG SP022, KDK KKP4819D, EUROELECTRIC 3410, SAMIL SP-106B, MOONSUNG EP-48E, HIGH PROJECT H.P 3). Contactati dealerul local pentru inlocuire. Cablul de alimentare in ISRAEL este PENCON(ZD16A), S/AFRICA APEX LEADS SA16 iar in NIGERIA, GHANA, KENYA si U.A.E este PENCON(UD13A1).
- Nu instalati cuptorul cu microunde in mediu cald si umed, precum in apropierea unui cuptor obisnuit sau radiator. Specificatiile sursei de alimentare a cuptorului trebuie respectate si orice extensie de cablu trebuie sa aiba acelasi standard ca si cablul de alimentare, livrat odata cu cuptorul. Stergeti interiorul si etansarea usii cu o carpa umeda, inainte de a folosi cuptorul cu microunde pentru prima data.



## Setarea ceasului

Cuptorul cu microunde are un ceas incorporat. Ora poate fi afisata in sistem de notare de 24 de ore sau de 12 ore. Trebuie sa setati ceasul:

- Atunci cand instalati cuptorul cu microunde pentru prima data
- Dupa o cadere de tensiune

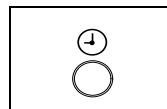
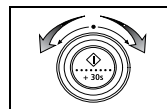
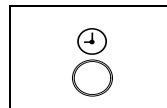
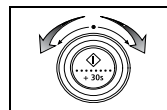
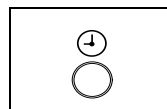
☒ Nu uitati sa resetati ceasul atunci cand, se face trecerea de la ora de vara la cea de iarna, si invers.



1. Pentru a afisa timpul in...  
Notare de 24 de ore  
Notare de 12 ore
- Atunci apasati butonul  ...  
O data  
De doua ori
2. Rotiti butonul prezentat in figura, pentru a seta ora.
3. Apasati butonul  .
4. Rotiti butonul prezentat in figura, pentru a seta minutele.
5. Apasati butonul  .

RO

## Ce trebuie facut atunci cand cuptorul nu functioneaza corect

RO

*Daca aveti una din problemele enumerate mai jos, incercati solutiile date.*

- ◆ Este normal.
    - Aparitia condensului in interiorul cuptorului cu microunde.
    - Iesirea aerului pe langa usa si carcasa exterioara.
    - Reflectarea luminii pe langa usa si carcasa exterioara.
    - Iesirea aburilor pe langa usa cuptorului.
  - ◆ Cuptorul nu functioneaza atunci cand apasati butonul ◊ .
    - Usa este inchisa complet?
  - ◆ Alimentul nu este preparat deloc.
    - Ati setat timpul corect si/ sau ati apasat butonul ◊ ?
    - Usa este inchisa?
    - Ati supraincarcat circuitul electric si ati provocat arderea unei siguranta sau declansarea unui intreruptor automat?
  - ◆ Alimentul este prea mult sau prea putin preparat.
    - Ati setat durata de preparare corespunzator cu tipul alimentului?
    - Ati ales un nivel de putere corespunzator?
  - ◆ Apar scantei si arc electric in interiorul cuptorului cu microunde.
    - Ati folosit vesela cu ornamente metalice?
    - Ati lasat o furculita sau o ustensila metalica in interiorul cuptorului?
    - Folia de aluminiu este prea aproape de peretii interiori ai cuptorului?
  - ◆ Cuptorul cu microunde provoaca interferente cu radio-ul sau televizorul.
    - O usoara interferenta poate fi observata la radio sau televizor, atunci cand cuptorul functioneaza. Este normal. Pentru a rezolva aceasta problema, instalati cuptorul cu microunde departe de radio, televizor sau antene
    - Daca interferenta este detectata de catre procesorul cuptorului, afisajul ar putea fi resetat. Pentru a rezolva aceasta, deconectati cablul de alimentare si apoi reconectati-l. Resetati timpul.
- ✉ Daca informatiile de mai sus nu va ajuta sa rezolvati problema, contactati dealer-ul local sau centrul service SAMSUNG.

## Preparare/ Reincalzire

*Urmatoarea procedura va arata cum puteti prepara sau reincalzi alimente. Verificati intotdeauna setarile facute pentru preparare, inainte de a lasa cuptorul nesupravegheat.*

*Intai, asezati alimentul in centrul platanului. Inchideti usa.*

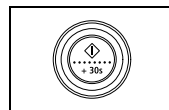
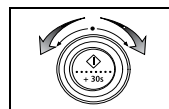
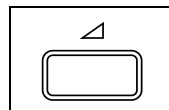

1. Apasati butonul ◀ .  
Rezultat Indicatia 850W (puterea maxima de preparare) este afisata.  
Selectati nivelul corespunzator de putere apasand din nou butonul ◀ ,pana ce nivelul dorit este afisat.  
Vedeti tabelul nivelelor de putere din pagina urmatoare.
2. Setati timpul de preparare rotind butonul la pozitia dorita.
3. Apasati butonul ◊ .  
Rezultat Se aprinde lumina cuptorului si platanul incepe sa se roteasca.  
Prepararea incepe si atunci cand se termina cuptorul emite patru bip-uri

- ✎ Nu porniti niciodata cuptorul cu microunde, atunci cand acesta este gol.
- ✉ Daca doriti sa incalziti mancare intr-un timp scurt la nivel de putere maxim (850W), apasati butonul **+30s** o data pentru fiecare 30 de secunde de timp de preparare. Cuptorul porneste imediat.

## Nivele putere

Puteti alege unul dintre nivelele de putere de mai jos.

Nivel putere	lesire
Ridicat	850 W
Mediu ridicat	600 W
Mediu	450 W
Mediu scazut	300 W
Dezghetare	180 W
Scazut	100 W

- ☒ Daca selectati un nivel ridicat de putere, timpul de preparare trebuie sa scada.
- ☒ Daca selectati un nivel scazut de putere, timpul de preparare trebuie sa creasca.

Daca doriti sa mariti timpul de preparare rotiti butonul astfel:

Timp	Crestere timp
pana la 1 min	5 sec. unit
1 - 3 min	10 sec. unit
3 - 10 min	30 sec. unit
10 - 20 min	1 min unit
20 - 40 min	2 min unit
40 - 99 min	5 min unit

## Oprirea prepararii

Puteti opri prepararea in orice moment, pentru a verifica alimentul.

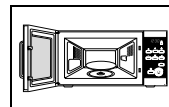

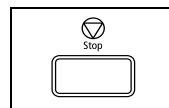

1. Pentru a opri temporar prepararea; Deschideti usa.

**Rezultat :** Prepararea se opreste. Pentru a continua, inchideti usa si apasati din nou butonul .



2. Pentru a opri complet prepararea; Apasati butonul .

**Rezultat :** Prepararea se opreste. Daca doriti sa anulati setarile prepararii, apasati din nou butonul Cancel (.

 Puteti anula orice setare inainte de inceperea prepararii, apasand butonul **Cancel** (.

## Ajustarea timpului de preparare

Puteti creste timpul de preparare apasand butonul +30s o data pentru fiecare 30 de secunde ce doriti sa fie adaugate.

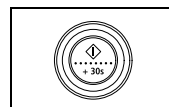

Apasati butonul **+30s** o data pentru fiecare 30 de secunde ce doriti sa fie adaugate.

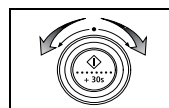

In timpul prepararii, pentru a ajusta timpul de preparare, invartiti butonul catre stanga sau dreapta.

RO

## Folosirea funcțiunii Auto Reincalzire

RO

Funcțiunea de Auto Reincalzire este programată cu trei timpi de preparare. Nu este nevoie să setați nici timpul de preparare și nici nivelul de putere. Puteți ajusta numărul de porții prin simpla rotire a butonului.

Intai, asezați alimentul în centrul platanului, apoi închideți usa.

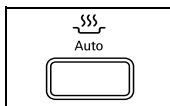

1. Selectați tipul alimentului ce doriți să îl preparați apăsând butonul **Auto Reheat** (Auto), o dată sau de mai multe ori.

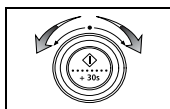

2. Selectați mărimea porției rotind butonul. (Vedeți tabelul din pagina următoare.)



3. Apasați butonul .  
Rezultat : Începe prepararea. Atunci când se termină:
  - 1) Cuptorul emite patru bip-uri.
  - 2) Semnalul de reamintire emite trei bip-uri (la fiecare minut).
  - 3) Timpul curent este afișat.

☒ Folosiți numai recipiente compatibile și sigure.

## Setările funcțiunii Auto Reincalzire

Următorul tabel prezintă diferite programe de Auto Reincalzire, cantități, timp de așteptare și recomandări potrivite.

Buton	Aliment	Portie	Timp de așteptare	Recomandari
1.	Gata preparat (rece)	300-350 g 400-450 g	3 min.	Asezați alimentul pe o farfurie ceramică și acoperiți cu pelicula. Acest program este potrivit pentru mâncare constând în 3 elemente (de ex. carne cu sos, legume, orez sau paste).
2.	Gata preparat (congelat)	300 -350 g 400 -450 g	4 min.	Verificați dacă vasul livrat cu alimentul congelat este potrivit pentru microunde. Întepați alimentul sau pelicula. Asezați alimentul în centrul platanului. Alimentele congelate preparate constau din combinații de 3 componente (de exemplu carne și sos, legumă, orez sau paste).
3.	Bauturi Cafea, lapte, ceai, apă la temperatura camerei	150 ml (1 ceașcă) 250 ml (1 cană)	1-2 min.	Turnați lichidul într-o ceașcă ceramică și încălziți încălziți neacoperit. Asezați o ceașcă (150 ml) în centrul platanului. Amestecați bauturile înainte și după timpul de așteptare.

## Folosirea functiunii Auto Dezghetare

Funcțiunea de Auto Dezghetare va permite sa dezghetati carne, pasari, peste. Timpul de dezghetare si nivelul de putere sunt setate automat.

✉ Folositi numai tipuri de vase recomandate pentru cuptorul cu microunde.

Intai, asezati alimentul congelat in centrul platanului si apoi inchideti usa.

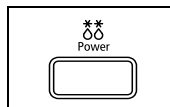

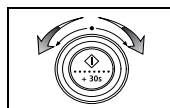

1. Apasati **Auto Power Defrost** (  ).

**Rezultat:** Este afisata urmatoarea indicatie: 

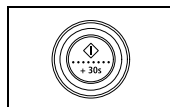

2. Selectati greutatea alimentului invartind butonul. Este posibil sa setati maxim 1500g.



3. Apasati butonul .

**Rezultat:**



- ◆ Incepe dezghetarea.
- ◆ Cuptorul va emite un bip la jumatatea dezghetarii, pentru a va aminti sa intoarceti alimentul.
- ◆ Apasati , pentru a opri dezghetarea.

✉ Puteti dezgheta alimentele manual. Pentru aceasta, selectati functiunea reincalzire/ preparare cu nivel de putere de 180W. Pentru detalii, vedeti capitolul "Reincalzire/Preparare" de la pagina 6.

## Setarile functiunii Auto Dezghetare

Urmatorul tabel prezinta diferite programe de auto dezghetare, cantitati, timp de asteptare si recomandari potrivite.

Indepartati orice tip de material de ambalare, inainte de dezghetare. Asezati alimentele congelate pe o farfurie ceramica dreapta.

Aliment	Portie	Timp de asteptare	Recomandari
 Carne	200-1500g	15-60min.	Inveliti marginile in folie de aluminiu. Intoarceti alimentul atunci cand, cuptorul emite un bip.
 Pasare			Acest program este potrivit pentru carne pentru cotlete, fripturi, chiftele, bucati de pui,
 Peste			pui intreg sau file de peste.

RO

## Folosirea functiunii Power Steam

RO

Folosind functiunea Power Steam, timpul de preparare este setat automat. Puteti ajusta numarul de portii de servire rotind butonul de selectare. Folositi intotdeauna dispozitivul de preparare cu aburi, din material plastic. Intai, asezati dispozitivul in centrul platanului, apoi inchideti usa.

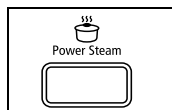

1. Selectati tipul alimentului ce doriti sa il preparati apasand **Power Steam** (  ) o data sau de mai multe ori.





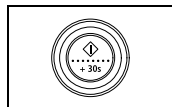

2. Selectati marimea portiei rotind butonul. (Vedeti tabelul din pagina urmatoare).



3. Apasati butonul  .  
**Rezultat :** Incepe prepararea. Atunci cand se termina:  
 1) Cuptorul emite patru bip-uri.  
 2) Semnalul de reamintire emite trei bip-uri (la fiecare minut).  
 3) Timpul curent este afisat.

✉ Folositi numai recipiente compatibile si sigure.

Urmatorul tabel prezinta 4 programe automate ale functiunii Power Steam, cantitati, timp de asteptare si recomandari corespunzatoare. Folositi intotdeauna dispozitivul de aburi atunci cand utilizati aceasta functiune.

Cod / Aliment	Portie	Timp de asteptare	Recomandari
1.  <b>Orez</b>	250 g 375 g	4-5 min.	Introduceti orezul alb in dispozitivul de preparare. Adaugati 500 ml de apa rece pentru 250 g de orez si adaugati 750 ml de apa pentru 375 g orez. Inchideti capacul dispozitivului. Dupa preparare, indepartati umezeala din interior, folosind hartie de bucatarie.
2.  <b>Cartofi decojiti</b>	100-150 g 200-250 g 300-350 g 400-450 g 500-550 g	2-3 min.	Dupa curatare cantariti, spalati si taiati cartofii in bucati de aceeasi marime. Introduceti apoi cartofii in dispozitivul de preparare cu aburi. Adaugati 15-30 ml (1-2 linguri) de apa pentru o cantitate de 100-350 g si 45-60 ml (3-4 linguri) de apa pentru o cantitate de 400-550 g. Inchideti capacul dispozitivului.
3.  <b>Legume proaspete</b>	100-150 g 200-250 g 300-350 g 400-450 g	1-2 min.	Dupa spalare, cantariti, curatati si taiati legumele in bucati de aceeasi marime. Introduceti legumele in dispozitivul de preparare cu aburi. Adaugati 30 ml (2 linguri) de apa pentru prepararea unei cantitati de 100-350 g, si adaugati 45 ml (3 linguri) de apa pentru o cantitate de 400-450 g. Inchideti capacul dispozitivului. Dupa preparare, amestecati inainte de timpul de asteptare.
4.  <b>Compot de fructe</b>	100-150 g 200-250 g 300-350 g 400-450 g	2-3 min.	Dupa curatare, cantariti si spalati legumele proaspete apoi taiati-le in felii sau cuburi de aceeasi marime. Introduceti in dispozitiv. pentru prepararea a 100-350g de fructe adaugati 15-30 ml (1-2 linguri.) de apa, pentru 400-450 adaugati 45ml (3linguri.). Adaugati 1-2 linguri de zahar. Inchideti capacul dispozitivului. Amestecati bine dupa preparare. Acest program este potrivit pentru mere, pere, caise, prune, mango si ananas.

## Funcțiunea de deodorizare

Folositi aceasta funcțiune dupa prepararea unui aliment cu miros puternic sau atunci cand exista mult fum in interiorul cuptorului.

Intai curatati interiorul cuptorului.

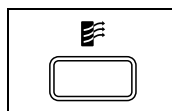



Apasati butonul **Deodorization** (  ) dupa ce ati curatat cuptorul. Vetii auzi patru semnale sonore.

- ☒ Timpul de deodorizare este setat, din fabrica, la 5 minute. Acesta poate creste cu 30 secunde la fiecare apasare a butonului **+30s**.
- ☒ Puteti ajusta timpul de deodorizare si prin rotirea butonului catre dreapta sau stanga.
- ☒ Timpul de deodorizare poate fi de maxim 15 minute.

## Setarea timpului de asteptare

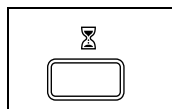
Butonul **Hold Time** poate fi folosit pentru setarea automata a unui timp de asteptare (fara preparare).



1. Apasati butonul .

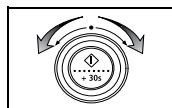

2. Selectati timpul de asteptare rotind butonul.



3. Apasati butonul .  
**Rezultat:** Incepe cronometrarea timpului setat. La final:  
1) Cutorul emite patru bipuri.  
2) Ora curenta este afisata din nou.

## Folosirea funcțiunii Custom Cook

Daca preparati sau reincalziti des diferite tipuri de alimente, puteti stoca timpul de preparare si nivelul de putere in memoria cuptorului, astfel incat nu mai este nevoie sa le setati de fiecare data.

Puteti introduce in memorie doua setari diferite.

### Memorarea setarilor

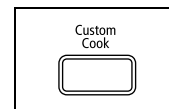

1. Pentru a programa...  
Prima setare  
A doua setare
- Atunci apasati butonul **Custom Cook ...**  
O data (Pe ecran este afisat P1)  
De doua ori (Pe ecran este afisat P2)
2. Setati programul de preparare in mod normal (timpul de preparare si nivelul de putere).

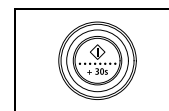
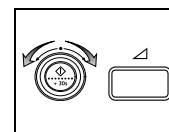

3. Apasati butonul .  
**Rezultat:** Programul de preparare setat este stocat acum in memoria cuptorului.

### Folosirea setarilor

Asezati intai alimentul in centrul platanului apoi inchideti usa.

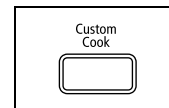

1. Pentru a selecta...  
Prima setare  
A doua setare
- Atunci apasati butonul **Custom Cook**  
O data (Pe ecran este afisat P1)  
De doua ori (Pe ecran este afisat P2)
2. Apasati butonul .  
**Rezultat:** Alimentul va fi preparat in functie de setarile memorate.

RO

## Oprirea semnalului sonor

RO

Puteti opri in orice moment semnalul sonor de avertizare al cuptorului.

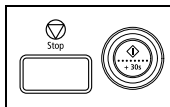



1. Apasati butoanele  si , in acelasi timp.

Rezultat :

Este afisata urmatoarea indicatie:

**OFF**

Cuptorul nu mai emite semnal, la apasarea butoanelor.

2. Pentru a activa din nou semnalul sonor, apasati butoanele  si  inca o data, in acelasi timp.

Rezultat :

Este afisata urmatoarea indicatie:

**On**

Cuptorul va emite din nou semnal sonor.

## Blocarea cuptorului cu microunde

Cuptorul cu microunde este prevazut cu un program special *Child Safety*, care va permite sa blocati functionarea cuptorului, astfel incat, copiii sau persoanele nefamiliarizate cu acesta, sa nu il poata activa din greseala.

Puteti bloca, in orice moment, functionarea cuptorului.

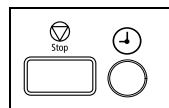

1. Apasati butoanele  si , in acelasi timp.



Rezultat :

Cuptorul este blocat (nu poate fi selectata nici o functie).

Este afisata indicatia "L".

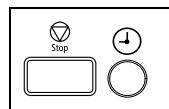
**L**



2. Pentru a debloca cuptorul, apasati din nou butoanele  si  in acelasi timp.

Rezultat : Cuptorul poate fi folosit normal.

## Ghid accesorii de preparare

*Pentru a prepara alimente in cuptorul cu microunde, microundele trebuie sa poata penetra alimentul, fara a fi reflectate sau absorbite de vesela folosita.*

*De aceea, trebuie sa alegeți cu grija accesoriile de preparare. Daca acestea sunt marcate cu simbolul "microwave safe", nu trebuie sa va mai faceti griji.*

*Urmatorul tabel prezinta diferite tipuri de accesorii de preparare si indica daca si cum trebuie folosite, in cuptorul cu microunde.*

Accesorii	Recomandate pt uz (microwave safe)	Comentarii
Folie de aluminiu	✓ X	Poate fi folosita in cantitati mici pentru a proteja anumite zone impotriva prajirii excesive. Arcul electric poate apare, daca folia este prea aproape de peretii cuptorului sau este in cantitate mare.
Farfurie crustata	✓	Nu preincalziti mai mult de opt minute.
Portelan si ceramica	✓	Portelanul, ceramica, vasele din lut sunt in mod obisnuit potrivite, numai daca nu sunt decorate cu ornamente metalice.
Vase de unica folosinta din carton, poliester	✓	Unele alimente congelate sunt ambalate in astfel de vase.
<b>Ambalaje Fast-food</b>		
• Cesti sau containere din polistiren	✓	Pot fi folosite pentru incalzire. Supraincalzirea poate duce la topirea polistirenilui.
• Pungi de hartie sau ziare	X	Pot cauza incendiu.
• Hartie reciclata sau vesela cu ornamente metalice	X	Pot cauza arc electric.
<b>Sticla</b>		
• Vesela de masa	✓	Poate fi folosita, numai daca nu este decorata cu ornamente metalice.
• Pahare fine	✓	Pot fi folosite pentru incalzire. Sticla fina se poate sparge sau crapa, la supraincalzire.
• Borcane de sticla	✓	Trebuie scos capacul. Numai pentru incalzire.

Metal		RO
• Vesela	X	Pot cauza arc electric sau incendiu.
• Ambalaje cu sigilii metalice	X	
Hartie		
• Farfurii, cesti, servetele, hartie de bucatarie	✓	Pentru incalzire si timp de preparare scurt. De asemenea, pentru absorbirea umiditatii.
• Hartie reciclata	X	Poate cauza arc electric.
Plastic		
• Containere	✓	Numai daca e plastic rezistent la incalzire. Unele tipuri de plastic, se deformeaza si se decoloreaza la temperaturi ridicate. Nu folositi melamina.
• Pelicula	✓	Poate fi folosita pentru a retine umezeala. Aceasta nu trebuie sa atinga alimentele. Aveti grija la indepartarea peliculei, deoarece vor fi eliberati aburi fierbinti.
• Pungi de congelare	✓ X	Numai daca rezista la fierbere. Nu trebuie sa fie ermetica. Daca e necesar, intepati cu furculita.
Hartie cerata		✓
		Poate fi folosita pentru retinerea umezelii. Impiedica formarea petelor de grasime, ulei.

✓ :Recomandat  
 ✓X:Folositi cu atentie  
 X :Periculos

## Curatarea cuptorului cu microunde

RO

*Urmatoarele parti ale cuptorului cu microunde trebuie curatate regulat, pentru a preveni formarea depunerilor de resturi alimentare si grasimi:*

- *Suprafetele interioare si exterioare*
- *Usa si etansarile acesteia*
- *Platanul si inelul de rulare*

☞ Asigurati-va intotdeauna ca etansarile usii sunt curate si usa se inchide corect.

1. Curatati suprafetele exterioare cu o carpa moale si apa calda cu sapun. Clatiti si uscati.
2. Indepartati orice pete de pe suprafetele interioare sau inelul de rulare cu o carpa cu sapun. Clatiti si uscati.
3. Pentru a curata mai usor depunerile si a indeparta mirosurile, asezati o ceasca cu suc de lamaie diluat pe platan, si incalziti timp de zece minute la putere maxima.
4. Spalati platanul, oricand este necesar.

☞ Nu turnati apa pe orificiile de ventilatie. Nu folositi niciodata produse abrazive sau solventi chimici. Aveti grija, atunci cand curatati etansarile, ca particulele de alimente sa nu:

- Se acumuleze
- Blocheze inchiderea corecta a usii

## Depozitare si reparatii cuptor cu microunde

*Cateva precautii simple trebuie luate, atunci cand depozitati sau transportati la centrul service cuptorul cu microunde.*

*Cuptorul nu trebuie folosit daca, usa sau incuietorile acesteia sunt defecte:*

- *Balama rupta*
- *Etansari deteriorate*
- *Carcasa defomata sau indoita*

*Reparatia trebuie facuta numai de catre personal service calificat.*

- ☞ Nu scoateti niciodata carcasa cuptorului cu microunde. Daca acesta este defect si necesita service sau nu sunteti siguri de starea lui:
  - Deconectati cablul de alimentare de la priza
  - Contactati cel mai apropiat centru service
- ☒ Daca doriti sa depozitati temporar cuptorul cu microunde, alegeți un loc uscat, fara praf.  
**Motiv:** Praful si umezeala pot afecta diferite componente ale cuptorului.
- ☒ Acest cuptor cu microunde nu este conceput pentru uz comercial.

## Specificatii tehnice

*SAMSUNG tinde sa isi imbunatateasca tot timpul produsele. Atat specificatiile design-ului cat si acest manual de instructiuni se pot schimba, fara notificare.*

<b>Model</b>	<b>MW87W</b>
<b>Sursa de alimentare</b>	230V ~ 50 Hz
<b>Putere de consum</b> Microunde	1250 W
<b>Putere de iesire</b>	100 W / 850 W (IEC-705)
<b>Frecventa de operare</b>	2450 MHz
<b>Magnetron</b>	OM75P(31)
<b>Metoda de racire</b>	Ventilator
<b>Dimensiuni</b> (W x H x D) Exterior Cavitate interioara cuptor	489 x 275 x 401.5 mm 330 x 211 x 329 mm
<b>Volum</b>	23 litri
<b>Greutate</b> Neta	aproximativ 13.5 kg

## Nota

RO

**SAMSUNG**

ELECTRONICS



# MICROWAVE OVEN

## Owner's Instructions

**MW87W**

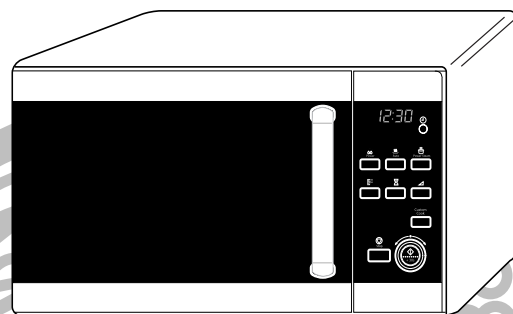

Oven .....	2
Accessories .....	2
Control Panel .....	2
Using this Instruction Booklet .....	3
Safety Precautions.....	3
Installing Your Microwave Oven .....	5
Setting the Time.....	5
What to Do if You are in Doubt or Have a Problem.....	6
Cooking / Reheating .....	6
Power Levels .....	7
Stopping the Cooking .....	7
Adjusting the Cooking Time.....	7
Using the Auto Reheat Feature .....	8
Auto Reheat Settings.....	8
Using the Auto Power Defrost Feature.....	9
Auto Power Defrost Settings .....	9
Using the Power Steam Function .....	10
Using the Deodorization Feature.....	11
Setting a Standing Time .....	11
Using the Custom Cook Feature .....	11
Switching the Beeper Off.....	12
Safety-Locking Your Microwave Oven .....	12
Cookware Guide.....	13
Cleaning Your Microwave Oven.....	14
Storing and Repairing Your Microwave Oven .....	14
Technical Specifications .....	15

## Oven

GB

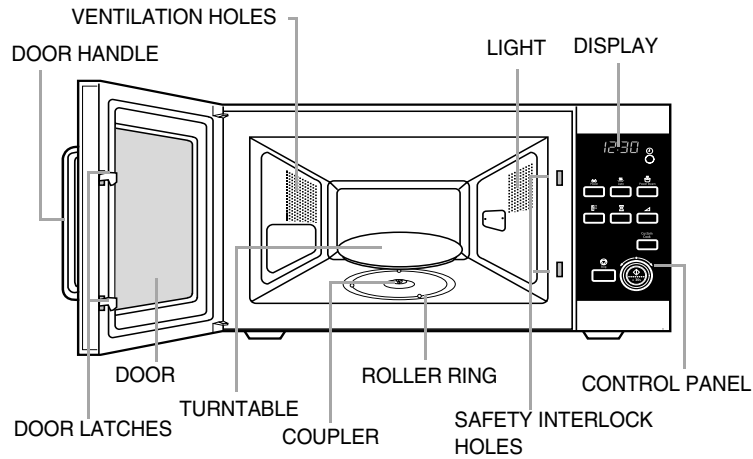

## Accessories

Depending on the model that you have purchased, you are supplied with several accessories that can be used in a variety of ways.

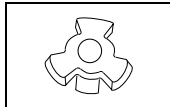

- Coupler**, already placed over the motor shaft in the base of the oven.

Purpose : The coupler rotates the turntable.

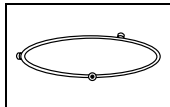

- Roller ring**, to be placed in the centre of the oven.

Purpose : The roller ring supports the turntable.

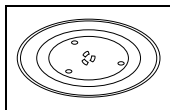

- Turntable**, to be placed on the roller ring with the centre fitting to the coupler.

Purpose : The turntable serves as the main cooking surface; it can be easily removed for cleaning.



- Power steam cooker**, see page 10.

Purpose : Use the plastic steam cooker when using power steam function.

**DO NOT** operate the microwave oven without the roller ring and turntable.

## Control Panel

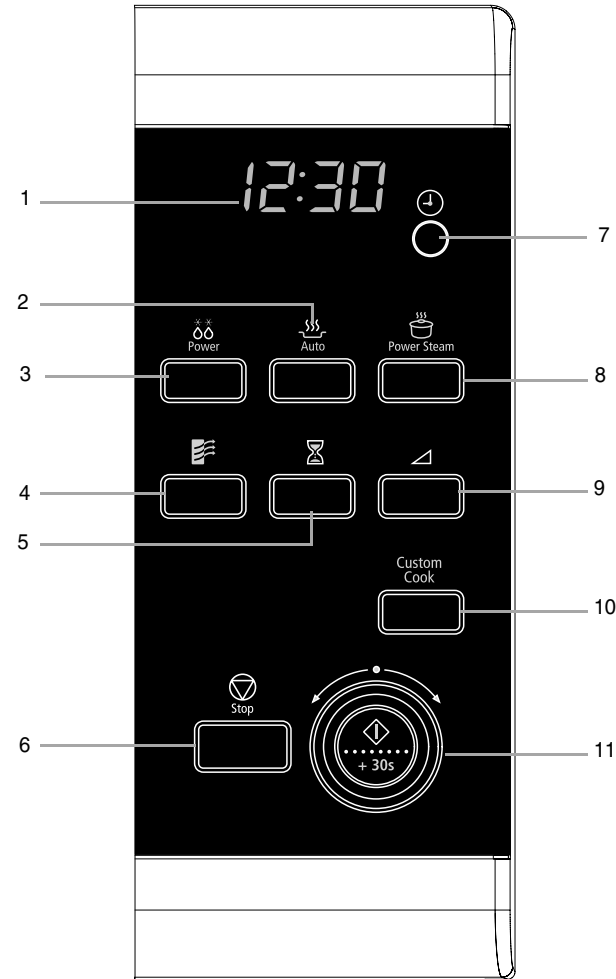

- |                              |  |
|------------------------------|--|
| 1. DISPLAY                   | 7. CLOCK SETTING   |
| 2. AUTO REHEAT SELECTION     | 8. POWER STEAM SELECTION   |
| 3. AUTO POWER DEFROST BUTTON | 9. POWER LEVEL SETTING   |
| 4. DEODORIZATION BUTTON      | 10. CUSTOM COOK BUTTON   |
| 5. STANDING TIME SETTING     | 11. START BUTTON/ DIAL KNOB (cook time, weight and serving size) |
| 6. STOP/CANCEL BUTTON        |  |

## Using this Instruction Booklet

You have just purchased a SAMSUNG microwave oven. Your Owner's Instructions contain much valuable information on cooking with your microwave oven:

- Safety precautions
- Suitable accessories and cookware
- Useful cooking tips

At the front of the booklet you will find illustrations of the oven, and more importantly the control panel, so that you can find the buttons more easily.

The step-by-step procedures use three different symbols.



Important

Note

Turn

### PRECAUTIONS TO AVOID POSSIBLE EXPOSURE TO EXCESSIVE MICROWAVE ENERGY

Failure to observe the following safety precautions may result in harmful exposure to microwave energy.

- (a) Under no circumstances should any attempt be made to operate the oven with the door open or to tamper with the safety interlocks (door latches) or to insert anything into the safety interlock holes.
- (b) Do not place any object between the oven door and front face or allow food or cleaner residues to accumulate on sealing surfaces. Ensure that the door and door sealing surfaces are kept clean by wiping after use first with a damp cloth and then with a soft dry cloth.
- (c) Do not operate the oven if it is damaged until it has been repaired by a qualified microwave service technician trained by the manufacturer. It is particularly important that the oven door closes properly and that there is no damage to the:
  - (1) Door, door seals and sealing surfaces
  - (2) Door hinges (broken or loose)
  - (3) Power cable
- (d) The oven should not be adjusted or repaired by anyone other than a properly qualified microwave service technician trained by the manufacturer.

## Safety Precautions

### IMPORTANT SAFETY INSTRUCTIONS.

#### READ CAREFULLY AND KEEP FOR FUTURE REFERENCE.

Before cooking food or liquids in your microwave oven, please check that the following safety precautions are taken.

1. **DO NOT** use any metallic cookware in the microwave oven:
  - Metallic containers
  - Dinnerware with gold or silver trimmings
  - Skewers, forks, etc.

Reason: Electric arcing or sparking may occur and may damage the oven.
2. **DO NOT** heat:
  - Airtight or vacuum-sealed bottles, jars, containers

Ex) Baby food jars

  - Airtight food.

Ex) Eggs, nuts in shells, tomatoes

Reason: The increase in pressure may cause them to explode.

Tip: Remove lids and pierce skins, bags, etc.
3. **DO NOT** operate the microwave oven when it is empty.
 

Reason: The oven walls may be damaged.

Tip: Leave a glass of water inside the oven at all times.  
The water will absorb the microwaves if you accidentally set the oven going when it is empty.
4. **DO NOT** cover the rear ventilation slots with cloths or paper.
 

Reason: The cloths or paper may catch fire as hot air is evacuated from the oven.
5. **ALWAYS** use oven gloves when removing a dish from the oven.
 

Reason: Some dishes absorb microwaves and heat is always transferred from the food to the dish. The dishes are therefore hot.
6. **DO NOT** touch heating elements or interior oven walls.
 

Reason: These walls may be hot enough to burn even after cooking has finished, even though they do not appear to be so. Do not allow inflammable materials to come into contact with any interior area of the oven. Let the oven cool down first.
7. To reduce the risk of fire in the oven cavity:
  - Do not store flammable materials in the oven
  - Remove wire twist ties from paper or plastic bags
  - Do not use your microwave oven to dry newspapers
  - If smoke is observed, keep the oven door closed and switch off or disconnect the oven from the power supply

GB

## *Safety Precautions (continued)*

**GB**

8. Take particular care when heating liquids and baby foods.
  - **ALWAYS** allow a standing time of at least 20 seconds after the oven has been switched off so that the temperature can equalize.
  - Stir during heating, if necessary, and **ALWAYS** stir after heating.
  - Take care when handling the container after heating. You may burn yourself, if the container is too hot.
  - A risk of delayed eruptive boiling exists.
  - To prevent delayed boiling and possible scalding, you should put a plastic spoon or glass stick into the beverages and stir before, during and after heating.

Reason: During the heating of liquids the boiling point can be delayed; this means that eruptive boiling can start after the container is removed from the oven. You may scald yourself.

  - In the event of scalding, follow these FIRST AID instructions:
    - \* Immerse the scalded area in cold water for at least 10 minutes.
    - \* Cover with a clean, dry dressing.
    - \* Do not apply any creams, oils or lotions.
  - **NEVER** fill the container to the top and choose a container that is wider at the top than at the bottom to prevent the liquid from boiling over. Bottles with narrow necks may also explode if overheated.
  - **ALWAYS** check the temperature of baby food or milk before giving it to the baby.
  - **NEVER** heat a baby's bottle with the teat on, as the bottle may explode if overheated.
9. Be careful not to damage the power cable.
  - Do not immerse the power cable or plug in water and keep the power cable away from heated surfaces.
  - Do not operate this appliance if it has a damaged power cable or plug.
10. Stand at arm's length from the oven when opening the door.
 

Reason: The hot air or steam released may cause scalding.
11. Keep the inside of the oven clean.
 

Reason: Food particles or spattered oils stuck to oven walls or floor can cause paint damage and reduce the efficiency of the oven.
12. You may notice a "Clicking" sound during operation (especially when the oven is defrosting).
 

Reason: This sound is normal when the electrical power output is changing.
13. When the microwave oven is operating without any load, the power will be cut off automatically for safety. You can operate normally after letting it stand for over 30 minutes.

### **IMPORTANT SAFETY INSTRUCTIONS**

During cooking, you should look into the oven from time to time when food is being heated or cooked in disposable containers of plastic, paper or other combustible materials.

### **IMPORTANT**

Young children should **NEVER** be allowed to use or play with the microwave oven. Nor should they be left unattended near the microwave oven when it is in use. Items of interest to children should not be stored or hidden just above the oven.

### **WARNING:**

If the door or door seals are damaged, the oven must not be operated until it has been repaired by a competent person.

### **WARNING:**

It is hazardous for anyone other than a competent person to carry out any service or repair operation which involves the removal of a cover which gives protection against exposure to microwave energy.

### **WARNING:**

Liquids and other foods must not be heated in sealed containers since they are liable to explode.

### **WARNING:**

Only allow children to use the oven without supervision when adequate instructions have been given so that the child is able to use the oven in a safe way and understands the hazards of improper use.

## Installing Your Microwave Oven

Place the oven on a flat, level surface that is strong enough to safely bear the weight of the oven.

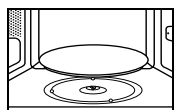
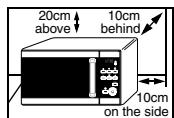

1. When you install your oven, Make sure there is adequate ventilation for your oven by leaving at least 10 cm (4 inches) of space behind, and on the sides of the oven, at least 20 cm (8 inches) of space above the oven.
2. Remove all packing materials inside the oven. Install the roller ring and turntable. Check that the turntable rotates freely.
3. This microwave oven has to be positioned so that plug is accessible.

⚠ **Never** block the air vents as the oven may overheat and automatically switch itself off. It will remain inoperable until it has cooled sufficiently.

⚠ For your personal safety, plug the cable into a 3-pin, 230 Volt, 50Hz, AC earthed socket. If the power cable of this appliance is damaged, it must be replaced by a special cable (I-SHENG SP022, KDK KKP4819D, EUROELECTRIC 3410, SAMIL SP-106B, MOONSUNG EP-48E, HIGH PROJECT H.P 3). Contact your local dealer to have it replaced. The power cable of ISRAEL is PENCON(ZD16A), S/AFRICA APEX LEADS SA16 and NIGERIA, GHANA, KENYA and U.A.E is PENCON(UD13A1).

⚠ **Do not** install the microwave oven in hot or damp surroundings like next to a traditional oven or radiator. The power supply specifications of the oven must be respected and any extension cable used must be of the same standard as the power cable supplied with the oven. Wipe the interior and the door seal with a damp cloth before using your microwave oven for the first time.

## Setting the Time

Your microwave oven has an inbuilt clock. The time can be displayed in either the 24-hour or 12-hour notation. You must set the clock:

GB

- When you first install your microwave oven
- After a power failure

⊠ Do not forget to reset the clock when you switch to and from summer or winter time.

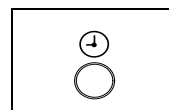

1. To display the time in the...  
 24-hour notation      Then press the ⬇ button... Once  
 12-hour notation      Twice

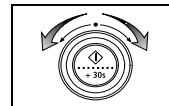

2. Turn the **dial knob** to set the hour.

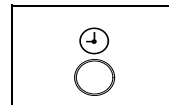

3. Press the ⬇ button.

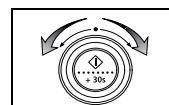

4. Turn the **dial knob** to set the minute.

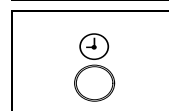



5. Press the ⬇ button.

## What to Do if You are in Doubt or Have a Problem

GB

If you have any of the problems listed below try the solutions given.

- ◆ This is normal.
    - Condensation inside the oven.
    - Air flow around the door and outer casing.
    - Light reflection around the door and outer casing.
    - Steam escaping from around the door or vents.
  - ◆ The oven does not start when you press the  button.
    - Is the door completely closed?
  - ◆ The food is not cooked at all
    - Have you set the timer correctly and/or pressed the  button?
    - Is the door closed?
    - Have you overloaded the electric circuit and caused a fuse to blow or a breaker to be triggered?
  - ◆ The food is either overcooked or undercooked
    - Was the appropriate cooking length set for the type of food?
    - Was an appropriate power level chosen?
  - ◆ Sparking and cracking occur inside the oven (arcing)
    - Have you used a dish with metal trimmings?
    - Have you left a fork or other metal utensil inside the oven?
    - Is aluminium foil too close to the inside walls?
  - ◆ The oven causes interference with radios or televisions
    - Slight interference may be observed on televisions or radios when the oven is operating. This is normal. To solve this problem, install the oven away from televisions, radios and aeriels.
    - If interference is detected by the oven's microprocessor, the display may be reset. To solve this problem, disconnect the power plug and reconnect it. Reset the time.
- ✉ If the above guidelines do not enable you to solve the problem, contact your local dealer or SAMSUNG after-sales service.

## Cooking / Reheating

The following procedure explains how to cook or reheat food.

**ALWAYS check your cooking settings before leaving the oven unattended.**

**First, place the food in the centre of the turntable. Then, close the door.**

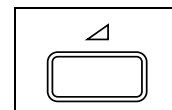

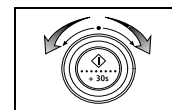

1. Press the  button.

**Result:** The 850W (maximum cooking power) indications are displayed:  
Select the appropriate power level by pressing the  button again until the corresponding wattage is displayed. Refer to the power level table.

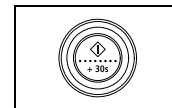

2. Set the cooking time by turning the **dial knob** as required.



3. Press the  button.

**Result:** The oven light comes on and the turntable starts rotating.  
Cooking starts and when it has finished the oven beeps four times.

 **Never** switch the microwave oven on when it is empty.

✉ If you wish to heat a dish for a short period of time at maximum power(850W), simply press the **+30s** button once for each 30 seconds of cooking time. The oven starts immediately.

## Power Levels

You can choose from among the power levels below.

Power Level	Output
HIGH	850 W
MEDIUM HIGH	600 W
MEDIUM	450 W
MEDIUM LOW	300 W
DEFROST	180 W
LOW / KEEP WARM	100 W

- ☒ If you select the higher power level, the cooking time must be decreased.
- ☒ If you select the lower power level, the cooking time must be increased.

If you want to add the cooking time by turning dial knob.

Time	Increasing Time
Up to 1 min	5 sec. unit
1 - 3 min	10 sec. unit
3 - 10 min	30 sec. unit
10 - 20 min	1 min unit
20 - 40 min	2 min unit
40 - 99 min	5 min unit

## Stopping the Cooking

You can stop cooking at any time to check the food.

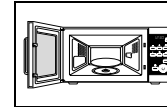

- To stop temporarily;  
Open the door.

**Result:** Cooking stops. To resume cooking, close the door and press again.

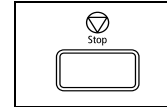

- To stop Completely:  
Press the button.

**Result:** The cooking stops.  
If you wish to cancel the cooking setting, press the Cancel( ) button again.

You can cancel any setting before you start cooking by simply pressing **Cancel**( ).

GB

## Adjusting the Cooking Time

You can increase the cooking time by pressing the +30s button once for each 30 seconds to be added.

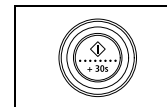

Press the **+30s** button once for each 30 seconds to be added.

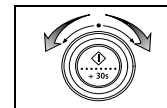

During the cooking, to increase or decrease the cooking time of your food, turn the **dial knob** right or left.

## Using the Auto Reheat Feature

GB

The Auto Reheat feature has three pre-programmed cooking times. You do not need to set either the cooking times or the power level. You can adjust the number of servings by turning the dial knob. First, place the food in the centre of the turntable and close the door.

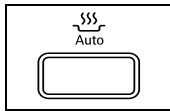

1. Select the type of food that you are cooking by pressing the **Auto Reheat** (Auto) button once or more times.

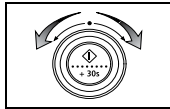

2. Select the size of the serving by turning the **dial knob**. (Refer to the table on the side.)

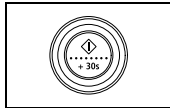

3. Press the button  
Result: Cooking starts. When it has finished:
  - 1) The oven beeps four times.
  - 2) The end reminder signal will beep 3 times (once every minutes)
  - 3) The current time is displayed again.

✉ Use only recipients that are microwave-safe.

## Auto Reheat Settings

The following table presents the various Auto Reheat Programmes, quantities, standing times and appropriate recommendations.

Code/ Food	Serving Size	Standing Time	Recommendations
1. <b>Ready Meal</b> (Chilled)	300-350 g 400-450 g	3 min.	Put on a ceramic plate and cover with microwave cling film. This programme is suitable for meals consisting of 3 components (e.g. meat with sauce, vegetables and a side dishes like potatoes, rice or pasta).
2. <b>Ready Meal</b> (Frozen )	300 - 350 g 400 - 450 g	4 min.	Take frozen ready meal and check if dish is suitable for microwave. Pierce film of ready meal. Put the frozen ready meal in the centre. This programme is suitable for frozen ready meals consisting of 3 components (e.g. meat with sauce, vegetables and a side dish like potatoes, rice or pasta).
3. <b>Drinks</b> <b>Coffee, milk,</b> <b>tea, water</b> (room-temperature)	150 ml (1 cup) 250 ml (1 mug)	1-2 min.	Pour into a ceramic cup (150 ml) or mug (250 ml) and place in the centre of turntable. Reheat uncovered. Stir carefully before and after standing time. Be careful while taking the cups out (see safety instructions for liquids).

## Using the Auto Power Defrost Feature

The Auto Power Defrost feature enables you to defrost meat, poultry or fish. The defrost time and power level are set automatically.

- ☒ Use only dishes that are microwave-safe.

First, place the frozen food in the centre of the turntable and close the door.

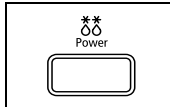

1. Press the **Auto Power Defrost** (  ) button.

**Result:** The following indication is displayed: 

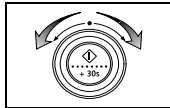

2. Select the food weight by turning the **dial knob**. It is possible to set up to a maximum of 1500g.



3. Press  button.

**Result:**

- ◆ Defrosting begins.
- ◆ The oven beeps halfway through defrosting to remind you to turn the food over.
- ◆ Press  button again to finish defrosting



- ☒ You can also defrost food manually. To do so, select the microwave cooking/reheating function with a power level of 180W. Refer to the section entitled "Cooking/Reheating" on page 6 for further details.

## Auto Power Defrost Settings

The following table presents the Power Defrost programme, quantities, standing times and appropriate recommendations.

Remove all kind of package material before defrosting. Place meat, poultry and fish on a flat ceramic plate.

GB

Food	Portion	Standing Time	Recommendation
 <b>Meat</b>	200-1500g	15-60min.	Shield the edges with aluminium foil. Turn the pieces over, when the oven beeps.
 <b>Poultry</b>			This programme is suitable for meat such as steaks, chops or minced meat, chicken pieces, whole chicken or fish fillets.
 <b>Fish</b>			

## Using the Power Steam Function

GB

With the power steam feature, the cooking time is set automatically.

You can adjust the number of servings by turning the dial knob.

Use the plastic steam cooker when using power steam function.

First, place the plastic steam cooker in the centre of the turntable and close the door.

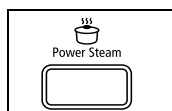

1. Select the type of food that you are cooking by pressing the **Power Steam** (  ) button once or more times.





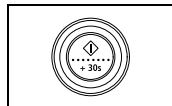

2. Select the size of the serving by turning the **dial knob**. (Refer to the table on the side page.)



3. Press the  button.  
**Result :** Cooking starts. When it has finished:
  - 1) The oven beeps four times.
  - 2) The end reminder signal will beep 3 times (once every minute)
  - 3) The current time is displayed again.

✉ Use only recipients that are microwave-safe.

The following table presents the 4 Auto Programs of the Power Steam function, quantities, standing times and appropriate recommendations. Use the plastic steam cooker when using power steam function.

Code / Food	Serving Size	Standing Time	Recommendations
1.  <b>Rice</b>	250 g 375 g	4-5 min.	Put white rice (parboiled) into the steam cooker. Add 500 ml cold water when cooking 250 g rice and add 750 ml water for 375 g rice. Close lid of steam cooker. After cooking remove moisture in the cavity by using kitchen paper.
2.  <b>Peeled Potatoes</b>	100-150 g 200-250 g 300-350 g 400-450 g 500-550 g	2-3 min.	Weigh the potatoes after peeling, washing and cutting into similar size. Put them into the steam cooker. Add 15-30 ml (1-2 tablespoons) water when steaming 100-350 g, add 45-60 ml (3-4 tablespoons) for 400-550 g. Close lid of steam cooker.
3.  <b>Fresh Vegetables</b>	100-150 g 200-250 g 300-350 g 400-450 g	1-2 min.	Weigh the vegetables after washing, cleaning and cutting into similar size. Put them into the steam cooker. Add 30 ml (2 tablespoons) water, when steaming 100-350 g, add 45 ml (3 tablespoons) for 400-450 g. Close lid of steam cooker. After steaming stir carefully before standing time.
4.  <b>Fruit Compote</b>	100-150 g 200-250 g 300-350 g 400-450 g	2-3 min.	Weigh the fresh fruits after peeling and washing and cut into similar slices or cubes. Put into steam cooker. When steaming 100-350g fruits add 15-30 ml (1-2 tbsp.) water, for 400-450 add 45ml (3 tbsp.). Additionally add 1-2 tbsp. sugar. Close lid of steam cooker. After steaming stir carefully. This programme is suitable for apples, pears, plums, apricots, mangoes or pineapple.

## Using the Deodorization Feature

Use this feature after cooking odorous food or when there is a lot of smoke in the oven interior.

First clean the oven interior.

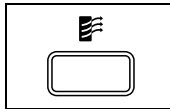

Press the **Deodorization** (☼) button after you have finished cleaning. you will hear four beeps.

- ☒ The deodorization time has been specified as 5 minutes. It increases by 30 seconds whenever the **+30s** button is pressed.
- ☒ You can also adjust deodorization time by turning the dial knob right or left.
- ☒ The maximum deodorization time is 15 minutes.

## Setting a Standing Time

The Hold Time can be used to set a standing time automatically (without microwave cooking).

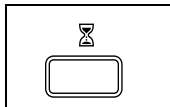

1. Press the ☼ button.

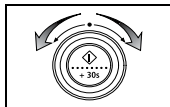

2. Select the standing time by turning the **dial knob**.

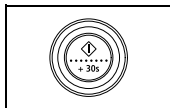

3. Press the ◊ button.  
**Result:** Standing time starts. When it has finished:  
 1) The oven beeps four times.  
 2) The current time is displayed again.

## Using the Custom Cook Feature

If you often cook or reheat the same types of dishes, you can store the cooking times and power levels in the oven's memory, so that you do not have to reset them each order.

You can store two different setting.

GB

### Storing the Setting

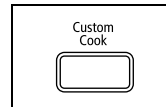

1. **To programme the...** **Then press the Custom Cook button**  
 First setting Once (Display is P1)  
 Second setting Twice (Display is P2)

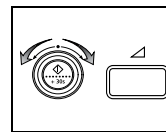

2. Set your cooking programme as usual (Cooking time and power level) see if necessary.

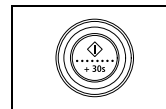

3. Press ◊ button.  
**Result:** Your setting are now stored in the oven's memory.

### Using the settings

First, place the food in the centre of the turntable and close the door

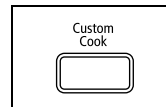

1. **To select the...** **Then press the Custom Cook button**  
 First setting Once (Display is P1)  
 Second setting Twice (Display is P2)

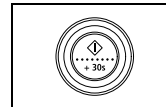



2. Press ◊ button.  
**Result:** The food is cooked as requested.

## Switching the Beeper Off

GB

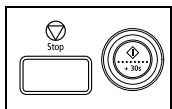
You can switch the beeper off whenever you want.





1. Press the  and  buttons at the same time.

Result :

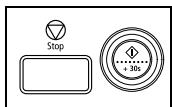
- ◆ The following indication is displayed.  

- ◆ The oven will not beep each time you press a button.



2. To switch the beeper back on, press the  and  buttons again at the same time.

Result :



- ◆ The following indication is displayed.  

- ◆ The oven operates with the beeper on again.

## Safety-Locking Your Microwave Oven

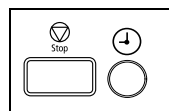
Your microwave oven is fitted with a special Child Safety programme, which enables the oven to be “locked” so that children or anyone unfamiliar with it cannot operate it accidentally.

The oven can be locked at any time.





1. Press the  and  buttons at the same time.

Result :

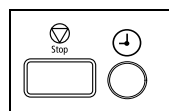
- ◆ The oven is locked (no functions can be selected).
- ◆ The display shows “L”.  



2. To unlock the oven, press the  and  buttons again at the same time.

Result :

The oven can be used normally.

## Cookware Guide

To cook food in the microwave oven, the microwaves must be able to penetrate the food, without being reflected or absorbed by the dish used.

Care must therefore be taken when choosing the cookware. If the cookware is marked microwave-safe, you do not need to worry.

The following table lists various types of cookware and indicates whether and how they should be used in a microwave oven.

Cookware	Microwave-Safe	Comments
<b>Aluminium foil</b>	✓ X	Can be used in small quantities to protect areas against overcooking. Arcing can occur if the foil is too close to the oven wall or if too much foil is used.
<b>Browning plate</b>	✓	Do not preheat for more than eight minutes.
<b>China and earthenware</b>	✓	Porcelain, pottery, glazed earthenware and bone china are usually suitable, unless decorated with a metal trim.
<b>Disposable polyester cardboard dishes</b>	✓	Some frozen foods are packaged in these dishes.
<b>Fast-food packaging</b>		
• Polystyrene cups containers	✓	Can be used to warm food. Overheating may cause the polystyrene to melt. May catch fire.
• Paper bags or newspaper	X	
• Recycled paper or metal trims	X	
<b>Glassware</b>		
• Oven-to-table ware	✓	Can be used, unless decorated with a metal trim.
• Fine glassware	✓	Can be used to warm foods or liquids. Delicate glass may break or crack if heated suddenly.
• Glass jars	✓	Must remove the lid. Suitable for warming only.
<b>Metal</b>		
• Dishes	X	May cause arcing or fire.
• Freezer bag twist ties	X	

<b>Paper</b>		
• Plates, cups, napkins and Kitchen paper	✓	For short cooking times and warming. Also to absorb excess moisture.
• Recycled paper	X	May cause arcing.
<b>Plastic</b>		
• Containers	✓	Particularly if heat-resistant thermoplastic. Some other plastics may warp or discolour at high temperatures. Do not use Melamine plastic.
• Cling film	✓	Can be used to retain moisture. Should not touch the food. Take care when removing the film as hot steam will escape.
• Freezer bags	✓ X	Only if boilable or oven-proof. Should not be airtight. Prick with a fork, if necessary.
<b>Wax or grease-proof paper</b>	✓	Can be used to retain moisture and prevent spattering.

GB

- ✓ :Recommended
- ✓X :Use Caution
- X :Unsafe

## *Cleaning Your Microwave Oven*

**GB**

*The following parts of your microwave oven should be cleaned regularly to prevent grease and food particles from building up:*

- *Inside and outside surfaces*
- *Door and door seals*
- *Turntable and Roller rings*



**ALWAYS** ensure that the door seals are clean and the door closes properly.



Failure to maintain the oven in a clean condition could lead to deterioration of the surface that could adversely affect the of the appliance and possibly result in a hazardous situation.

1. Clean the outside surfaces with a soft cloth and warm, soapy water. Rinse and dry.
2. Remove any splashes or stains on the inside surfaces or on the roller ring with a soapy cloth. Rinse and dry.
3. To loosen hardened food particles and remove smells, place a cup of diluted lemon juice on the turntable and heat for ten minutes at maximum power.
4. Wash the dishwasher-safe plate whenever necessary.



**DO NOT** spill water in the vents. **NEVER** use any abrasive products or chemical solvents. Take particular care when cleaning the door seals to ensure that no particles:

- Accumulate
- Prevent the door from closing correctly

## *Storing and Repairing Your Microwave Oven*

*A few simple precautions should be taken when storing or having your microwave oven serviced.*

*The oven must not be used if the door or door seals are damaged:*

- *Broken hinge*
- *Deteriorated seals*
- *Distorted or bent oven casing*

*Only a qualified microwave service technician should perform repair*



**NEVER** remove the outer casing from the oven. If the oven is faulty and needs servicing or you are in doubt about its condition:

- Unplug it from the wall socket
- Contact the nearest after-sales service centre



If you wish to store your oven away temporarily, choose a dry, dust-free place.

**Reason:** Dust and damp may adversely affect the working parts in the oven.



This microwave oven is not intended for commercial use.

## Technical Specifications

*SAMSUNG strives to improve its products at all times. Both the design specifications and these user instructions are thus subject to change without notice.*

<b>Model</b>	<b>MW87W</b>
<b>Power source</b>	230V ~ 50 Hz
<b>Power consumption</b> Microwave	1250 W
<b>Output power</b>	100 W / 850 W (IEC-705)
<b>Operating frequency</b>	2450 MHz
<b>Magnetron</b>	OM75P(31)
<b>Cooling method</b>	Cooling fan motor
<b>Dimensions (W x H x D)</b> Outside Oven cavity	489 x 275 x 401.5 mm 330 x 211 x 329 mm
<b>Volume</b>	23 liter
<b>Weight</b> Net	13.5 kg approx

## Note

**GB**

