



## DVD PLAYER

Chassis : Spino

DVD-P355B/XEU, XET, XEE, SED, XEO,  
XEC, XEL, FOU, XEG, XEH,  
XEV

SAMSUNG

SERVICE MANUAL

DVD-P355B

# SERVICE Manual



### DVD PLAYER

### Merit & Character regarding Product

- ① 41mm With LED Module
- ② Playback MPEG4 DVD-Audio
- ③ ZORAN Vaddis7 1-Chip Solution

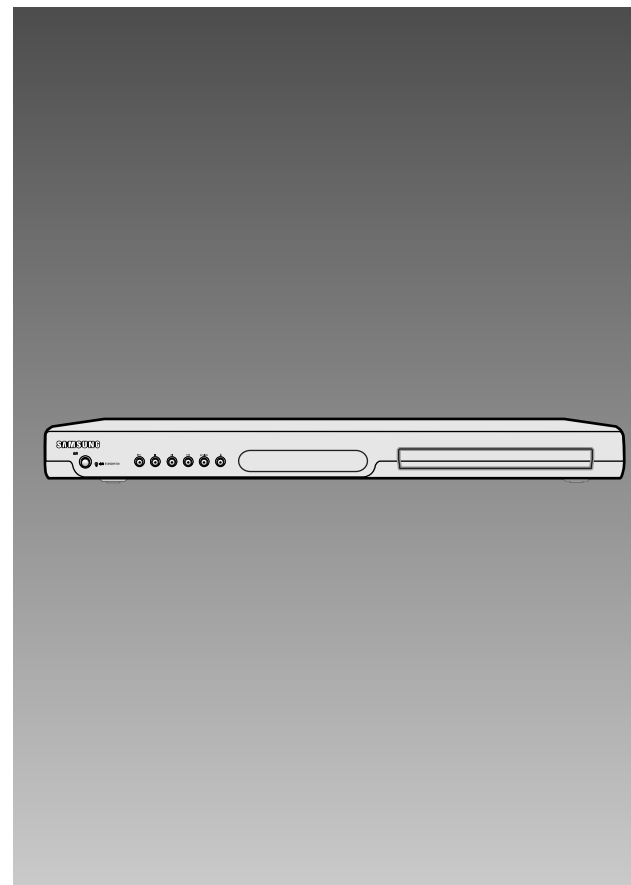

This Service Manual is a property of Samsung Electronics Co.,Ltd.  
Any unauthorized use of Manual can be punished under applicable  
international and/or domestic law.

© Samsung Electronics Co., Ltd. JUN . 2005  
Printed in Korea  
AK82-0000929A



# CONTENTS

<b>1. Precautions</b>	<b>1-1 ~ 1-6</b>
1-1 Safety Precautions	(1-1)
1-2 Servicing Precautions	(1-3)
1-3 ESD Precautions	(1-4)
1-4 Handling the optical pick-up	(1-5)
1-5 Pick-up disassembly and reassembly	(1-6)
<b>2. Product Specification</b>	<b>2-1 ~ 2-4</b>
2-1 Product Specification	(2-1)
2-2 Chassis Product Specification	(2-2)
2-3 Option Product Specification	(2-3)
<b>3. Alignment and Adjustments</b>	<b>3-1 ~ 3-4</b>
3-1 Location of Test Point	(3-1)
3-2 Skew Adjustment	(3-2)
<b>4. Disassembly and Reassembly</b>	<b>4-1 ~ 4-10</b>
4-1 Cabinet and PCB	(4-1)
4-2 Deck	(4-6)
<b>5. Troubleshooting</b>	<b>5-1 ~ 5-14</b>
<b>6. Exploded View and Parts List</b>	<b>6-1 ~ 6-6</b>
6-1 Cabinet Assembly	(6-2)
6-2 DVD Mechanical Parts	(6-4)
<b>7. Electrical Parts List</b>	<b>7-1 ~ 7-6</b>



# CONTENTS

<b>8. Block Diagram</b>	<b>8-1 ~ 8-2</b>
<b>9. Wiring Diagram</b>	<b>9-1 ~ 9-2</b>
<b>10. PCB Diagrams</b>	<b>10-1 ~ 10-4</b>
10-1 Main PCB	(10-2)
<b>11. Schematic Diagrams</b>	<b>11-1 ~ 11-8</b>
11-1 Power Drive	(11-2)
11-2 Servo	(11-3)
11-3 AV-Decoder	(11-4)
11-4 Front Micom	(11-5)
11-5 Audio	(11-6)
11-6 Video	(11-7)
<b>12. Operating Instructions and Installation</b>	<b>12-1 ~ 12-50</b>
<b>13. Circuit Operating Descriptions</b>	<b>13-1 ~ 13-16</b>
13-1 Power	(13-1)
13-2 RF	(13-7)
13-3 System Control	(13-9)
13-4 Servo	(13-10)
13-5 DVD Data Processor	(13-13)
13-6 Video	(13-14)
13-7 Audio	(13-15)



# CONTENTS

<b>14. Reference Information</b>	<b>14-1 ~ 14-16</b>
14-1 Introduction to DVD	(14-1)
14-2 DVD-Video Fromat	(14-3)
14-1 DVD-Audio	(14-9)
14-2 DivX	(14-12)

# 1. Precautions

## 1-1 Safety Precautions

1) Before returning an instrument to the customer, always make a safety check of the entire instrument, including, but not limited to, the following items:

(1) Be sure that no built-in protective devices are defective or have been defeated during servicing. (1) Protective shields are provided to protect both the technician and the customer. Correctly replace all missing protective shields, including any removed for servicing convenience.

(2) When reinstalling the chassis and/or other assembly in the cabinet, be sure to put back in place all protective devices, including, but not limited to, nonmetallic control knobs, insulating fish papers, adjustment and compartment covers/shields, and isolation resistor/capacitor networks. Do not operate this instrument or permit it to be operated without all protective devices correctly installed and functioning.

(2) Be sure that there are no cabinet openings through which adults or children might be able to insert their fingers and contact a hazardous voltage. Such openings include, but are not limited to, excessively wide cabinet ventilation slots, and an improperly fitted and/or incorrectly secured cabinet back cover.

(3) Leakage Current Hot Check-With the instrument completely reassembled, plug the AC line cord directly into a 120V AC outlet. (Do not use an isolation transformer during this test.) Use a leakage current tester or a metering system that complies with American National Standards Institute (ANSI) C101.1 Leakage Current for Appliances and Underwriters Laboratories (UL) 1270 (40.7). With the instrument's AC switch first in the ON position and then in the OFF position, measure from a known earth ground (metal water pipe, conduit, etc.) to all exposed metal parts of the instrument (antennas, handle brackets, metal cabinets, screwheads, metallic overlays, control shafts, etc.), especially any exposed metal parts that offer an electrical return path to the chassis.

Any current measured must not exceed 0.5mA. Reverse the instrument power cord plug in the outlet and repeat the test. See Fig. 1-1.

Any measurements not within the limits specified herein indicate a potential shock hazard that must be eliminated before returning the instrument to the customer.

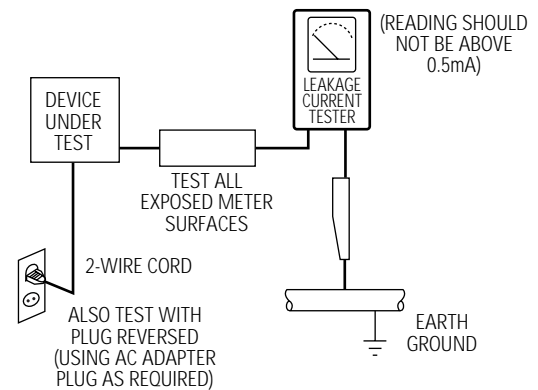

Fig. 1-1 AC Leakage Test

(4) Insulation Resistance Test Cold Check-(1) Unplug the power supply cord and connect a jumper wire between the two prongs of the plug. (2) Turn on the power switch of the instrument. (3) Measure the resistance with an ohmmeter between the jumpered AC plug and all exposed metallic cabinet parts on the instrument, such as screwheads, antenna, control shafts, handle brackets, etc. When an exposed metallic part has a return path to the chassis, the reading should be between 1 and 5.2 megohm. When there is no return path to the chassis, the reading must be infinite. If the reading is not within the limits specified, there is the possibility of a shock hazard, and the instrument must be repaired and rechecked before it is returned to the customer. See Fig. 1-2.

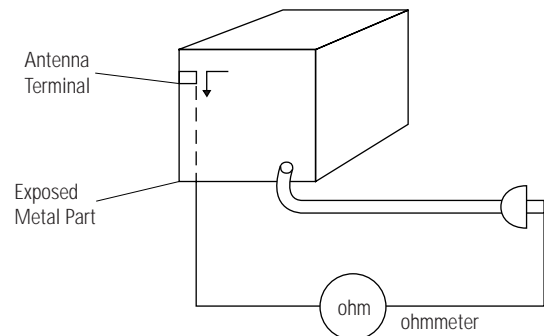



Fig. 1-2 Insulation Resistance Test

- 2) Read and comply with all caution and safety related notes on or inside the cabinet, or on the chassis.
- 3) Design Alteration Warning-Do not alter or add to the mechanical or electrical design of this instrument. Design alterations and additions, including but not limited to, circuit modifications and the addition of items such as auxiliary audio output connections, might alter the safety characteristics of this instrument and create a hazard to the user. Any design alterations or additions will make you, the servicer, responsible for personal injury or property damage resulting therefrom.
- 4) Observe original lead dress. Take extra care to assure correct lead dress in the following areas:
  - (1) near sharp edges, (2) near thermally hot parts (be sure that leads and components do not touch thermally hot parts), (3) the AC supply, (4) high voltage, and (5) antenna wiring. Always inspect in all areas for pinched, out-of-place, or frayed wiring. Do not change spacing between a component and the printed-circuit board. Check the AC power cord for damage.
- 5) Components, parts, and/or wiring that appear to have overheated or that are otherwise damaged should be replaced with components, parts and/or wiring that meet original specifications. Additionally, determine the cause of overheating and/or damage and, if necessary, take corrective action to remove any potential safety hazard.
- 6) Product Safety Notice-Some electrical and mechanical parts have special safety-related characteristics which are often not evident from visual inspection, nor can the protection they give necessarily be obtained by replacing them with components rated for higher voltage, wattage, etc. Parts that have special safety characteristics are identified by shading, an () or a () on schematics and parts lists. Use of a substitute replacement that does not have the same safety characteristics as the recommended replacement part might create shock, fire and/or other hazards. Product safety is under review continuously and new instructions are issued whenever appropriate.

## 1-2 Servicing Precautions

---

**CAUTION :** Before servicing units covered by this service manual and its supplements, read and follow the Safety Precautions section of this manual.

**Note :** If unforeseen circumstances create conflict between the following servicing precautions and any of the safety precautions, always follow the safety precautions. Remember: Safety First.

### 1-2-1 General Servicing Precautions

- (1) a. Always unplug the instrument's AC power cord from the AC power source before (1) re-moving or reinstalling any component, circuit board, module or any other instrument assembly, (2) disconnecting any instrument electrical plug or other electrical connection, (3) connecting a test substitute in parallel with an electrolytic capacitor in the instrument.
- b. Do not defeat any plug/socket B+ voltage interlocks with which instruments covered by this service manual might be equipped.
- c. Do not apply AC power to this instrument and /or any of its electrical assemblies unless all solid-state device heat sinks are correctly installed.
- d. Always connect a test instrument's ground lead to the instrument chassis ground before connecting the test instrument positive lead. Always remove the test instrument ground lead last.

**Note :** Refer to the Safety Precautions section ground lead last.

- (2) The service precautions are indicated or printed on the cabinet, chassis or components. When servicing, follow the printed or indicated service precautions and service materials.
- (3) The components used in the unit have a specified flame resistance and dielectric strength. When replacing components, use components which have the same ratings. Components identified by shading, by (⚡) or by (⚡) in the circuit diagram are important for safety or for the characteristics of the unit. Always replace them with the exact replacement components.

(4) An insulation tube or tape is sometimes used and some components are raised above the printed wiring board for safety. The internal wiring is sometimes clamped to prevent contact with heating components. Install such elements as they were.

(5) After servicing, always check that the removed screws, components, and wiring have been installed correctly and that the portion around the serviced part has not been damaged and so on. Further, check the insulation between the blades of the attachment plug and accessible conductive parts.

### 1-2-2 Insulation Checking Procedure

Disconnect the attachment plug from the AC outlet and turn the power ON. Connect the insulation resistance meter (500V) to the blades of the attachment plug. The insulation resistance between each blade of the attachment plug and accessible conductive parts(see note) should be more than 1 Megohm.

**Note :** Accessible conductive parts include metal panels, input terminals, earphone jacks, etc.

## 1-3 ESD Precautions

---

### Electrostatically Sensitive Devices (ESD)

Some semiconductor (solid state) devices can be damaged easily by static electricity.

Such components commonly are called Electrostatically Sensitive Devices(ESD). Examples of typical ESD devices are integrated circuits and some field-effect transistors and semiconductor chip components. The following techniques should be used to help reduce the incidence of component damage caused by static electricity.

- (1) Immediately before handling any semiconductor component or semiconductor-equipped assembly, drain off any electrostatic charge on your body by touching a known earth ground. Alternatively, obtain and wear a commercially available discharging wrist strap device, which should be removed for potential shock reasons prior to applying power to the unit under test.
- (2) After removing an electrical assembly equipped with ESD devices, place the assembly on a conductive surface such as aluminum foil, to prevent electrostatic charge buildup or exposure of the assembly.
- (3) Use only a grounded-tip soldering iron to solder or unsolder ESD devices.
- (4) Use only an anti-static solder removal devices. Some solder removal devices not classified as "anti-static" can generate electrical charges sufficient to damage ESD devices.
- (5) Do not use freon-propelled chemicals. These can generate electrical charges sufficient to damage ESD devices.
- (6) Do not remove a replacement ESD device from its protective package until immediately before your are ready to install it.(Most replacement ESD devices are packaged with leads electrically shorted together by conductive foam, aluminum foil or comparable conductive materials).

- (7) Immediately before removing the protective materials from the leads of a replacement ESD device, touch the protective material to the chassis or circuit assembly into which the device will be installed.

**CAUTION :** Be sure no power is applied to the chassis or circuit, and observe all other safety precautions.

- (8) Minimize bodily motions when handling unpackaged replacement ESD devices. (Otherwise harmless motion such as the brushing together of your clothes fabric or the lifting of your foot from a carpeted floor can generate static electricity sufficient to damage an ESD device).



## 1-4 Handling the optical pick-up

The laser diode in the optical pick up may suffer electrostatic breakdown because of potential static electricity from clothing and your body.

The following method is recommended.

- (1) Place a conductive sheet on the work bench (The black sheet used for wrapping repair parts.)
  - (2) Place the set on the conductive sheet so that the chassis is grounded to the sheet.
  - (3) Place your hands on the conductive sheet (This gives them the same ground as the sheet.)
  - (4) Remove the optical pick up block
  - (5) Perform work on top of the conductive sheet. Be careful not to let your clothes or any other static sources to touch the unit.
- ◆ Be sure to put on a wrist strap grounded to the sheet.
  - ◆ Be sure to lay a conductive sheet made of copper etc. Which is grounded to the table.

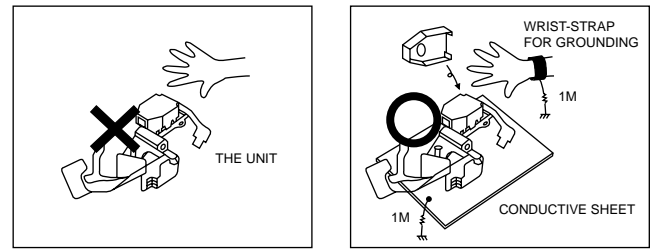

Fig.1-3

- (6) Short the short terminal on the PCB, which is inside the Pick-Up ASS'Y, before replacing the Pick-Up. (The short terminal is shorted when the Pick-Up Ass'y is being lifted or moved.)
- (7) After replacing the Pick-up, open the short terminal on the PCB.

## 1-5 Pick-up disassembly and reassembly

### 1-5-1 Disassembly

- 1) Remove the power cord.
- 2) Disassemble the Deck-Assy.
- 3) Make solder land 2 points short on Pick-up.  
(See Fig. 1-4)
- 4) Disassemble the Pick-up.

### 1-5-2 Assembly

- 1) Replace the Pick-up.
- 2) Remove the soldering 2 points on Pick-up.
- 3) Reassemble the Deck-Assy.

**Note :** If the assembly and disassembly are not done in correct sequence, the Pick-up may be damaged.

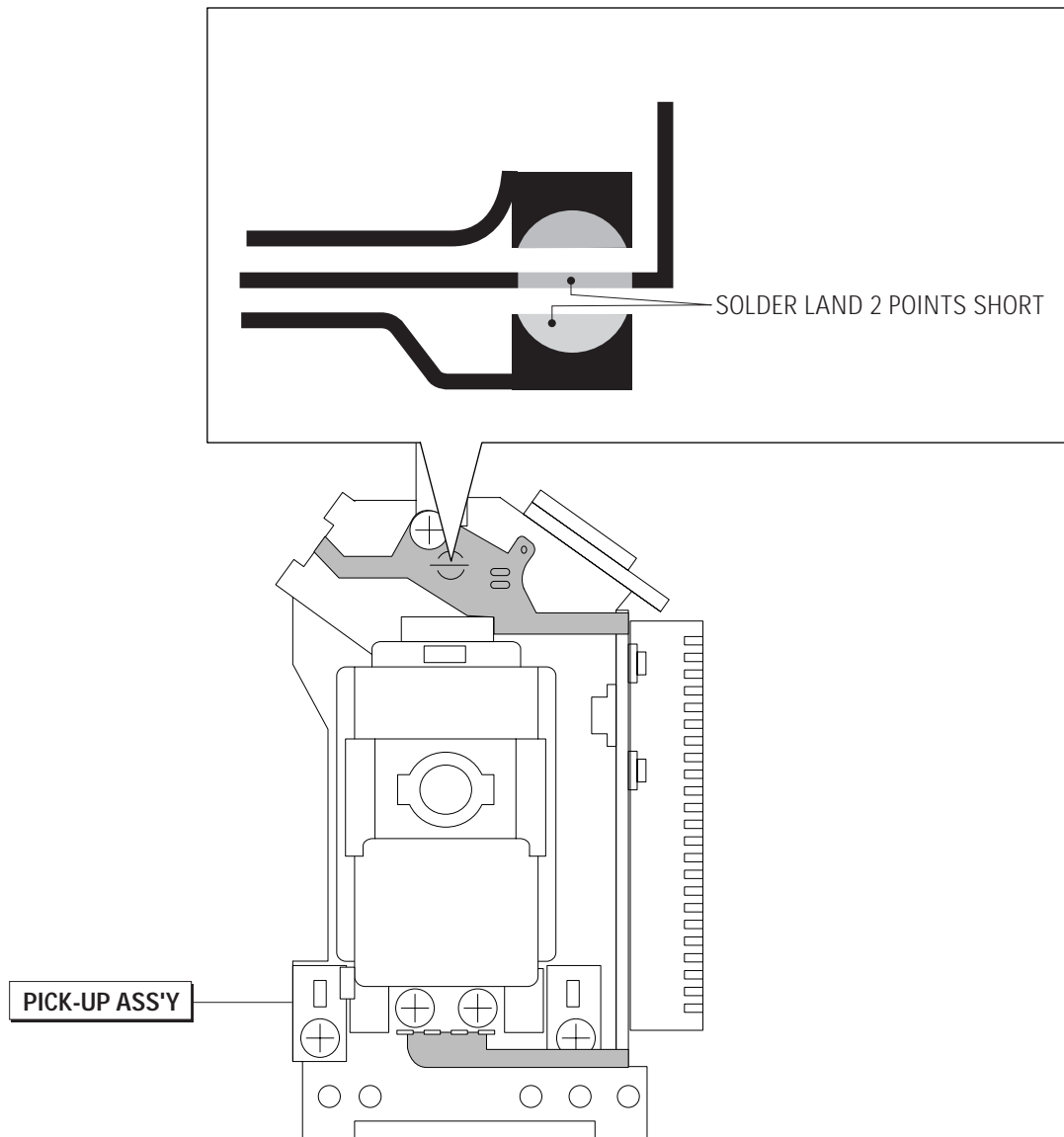

Fig. 1-4

## 2. Product Specification

### 2-1 Product Specification



<b>General</b>	Power Requirements	AC230V, 50Hz
	Power Consumption	10W
	Weight	1.7Kg
	Dimensions	430mm (W) x 207mm (D) x 42mm (H)
	Operating Temperature Range	+5°C to 35°C
	Operating Humidity Range	10% to 75%
<b>Disc</b>	DVD (Digital Versatile Disc)	Reading Speed : 3.49 ~ 4.06m/sec. Approx. Play Time (Single Sided, Single Layer Disc) : 135min.
	CD : 12cm (Compact Disc)	Reading Speed : 4.8 ~ 5.6m/sec. Maximum Play Time : 74min.
	CD : 8cm (Compact Disc)	Reading Speed : 4.8 ~ 5.6m/sec. Maximum Play Time : 20min.
	VCD : 12cm	Reading Speed : 4.8 ~ 5.6m/sec. Maximum Play Time : 74min. (Video+Audio)
<b>Video Output</b>	Composite Video	1 channel ; 1.0Vp-p (75ohm load)
	SCART Jack	R (Red) : 0.7 Vp-p (75ohm load) G (Green) : 0.7 Vp-p (75ohm load) B (Blue) : 0.7 Vp-p (75ohm load) Composite Video : 1.0 Vp-p (75ohm load) Luminance Signal : 1.0 Vp-p (75ohm load) Color Signal : 0.3 Vp-p (75ohm load)
	Component Video	Y: 1.0 Vp-p (75ohm load) Pr: 0.70 Vp-p (75ohm load) Pb: 0.70 Vp-p (75ohm load)
	S-Video	Luminance Signal : 1.0Vp-p (75ohm load) Chrominance Signal : 0.3Vp-p (75ohm loa)
	HDMI	High Definition Multimedia Interface (576p, 720p, 768p, 1080i)
<b>Audio Output</b>	SCART Jack	2 Channel : L(1/L), R(2/R)
	2 Channel	L(1/L), R(2/R)
	*Frequency Response	48KHz Sampling : 4Hz to 22KHz 96KHz Sampling : 4Hz to 44KHz
	*S/N Ratio	110dB
	*Dynamic Range	100dB
	*Total Harmonic Distortion	0.004%

\* : Nominal specification

## 2-2 Chassis Product Specification

MODEL	DVD-P250K/XSS	DVD-P255K/XSS	DVD-P350K/XSS	DVD-P355K/XAX
FLASH	2M	2M	2M	2M
RF	X	X	Ti-D	Ti-D
DRIVE	FAN8026	FAN8026	FAN8026	FAN8026
A/V DECODER	ZR36862	ZR36862	ZR36778	ZR36778
6dB_AMP	LA73054	LA73054	LA73054	LA73054
AUDIO DAC	PCM1753	PCM1753	PCM1753	PCM1753
AUDIO ADC	M65855P	M65855P	M65855P	M65855P
FRONTMICOM	eFHP5842	eFHP5842	eFHP5842	eFHP5842
MIC INPUT	1MIC	2MIC	1MIC	2MIC
NTSC	0	0	0	0
Default	PAL	PAL	PAL	NT
SCARTOUT	X	X	X	X
PSO	MULTI	MULTI	MULTI	MULTI
DTS	2CH/DIGI	2CH/DIGI	2CH/DIGI	2CH/DIGI
D-AUDIO	X	X	X	0
MPEG4	X	X	0	0
MP3	0	0	0	0
P-CD	0	0	0	0
WMA	0	0	0	0
VCD	0	0	0	0
SVCD	0	0	0	0
MEMORY CARD	X	X	X	X

## 2-3 Option Product Specification

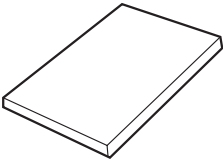
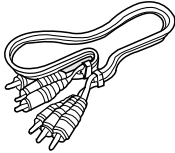
Description Fig	Description	Parts No	Remark
	Remote Control	AK59-00011K	Model Standard of DVD-P355B/XEL
	Batteries for Remote Control (AAA Size)	AC43-12002H	Model Standard of DVD-P355B/XEL S.N.A
	User's Manual	AK68-00632G	Model Standard of DVD-P355B/XEL
	Video/Audio Cable	AC39-42001R	Model Standard of DVD-P355B/XEL

### 3. Alignment and Adjustment

#### 3-1 Location of Test Point

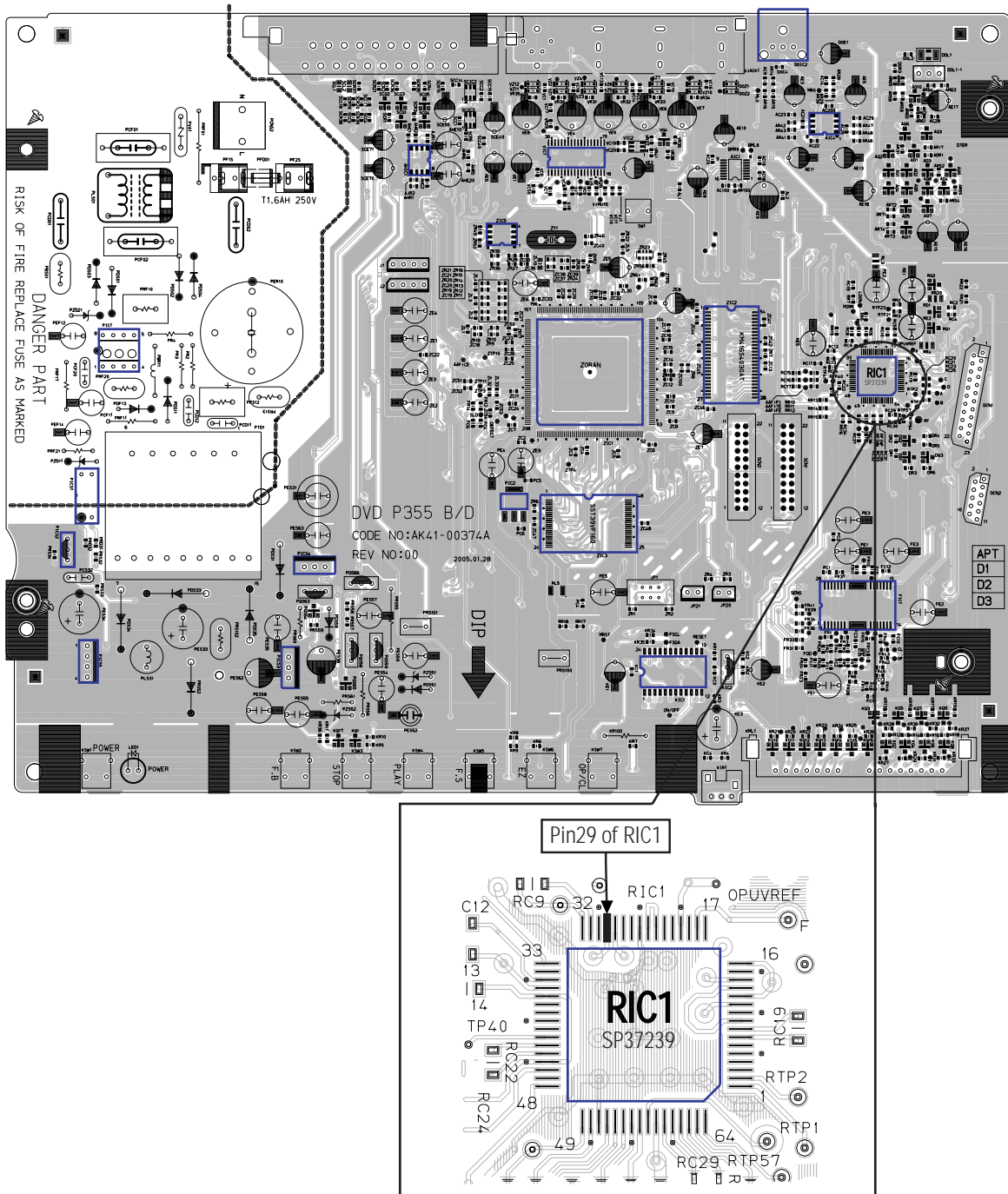

Fig. 3-1 Location of Test Point

### 3-2 Skew Adjustment

#### 3-2-1 Adjustment Spec. and Test Point

<Table 3-1>

◆ Test Disc ; Service not Available

Test Disc	Adjustment Spec.	Test Point	Adjustment Location
TDV-533 Chapter 14	Flat Waveform	"Pin 29 of RIC1" (Main PCB - Component Side) (See Fig. 3-1)	Screw A / B Ass'y Deck - Top Side (See Fig. 3-2)

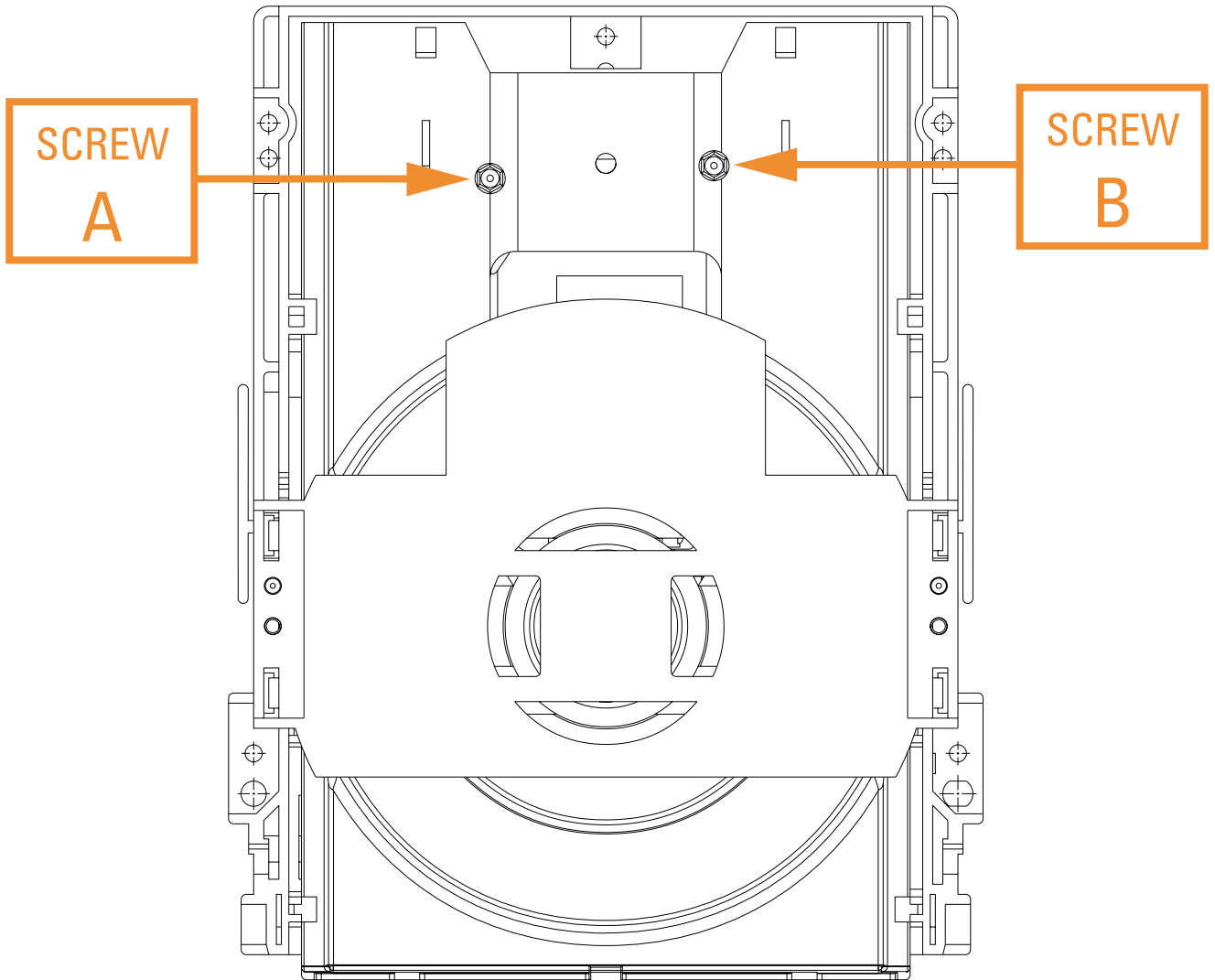
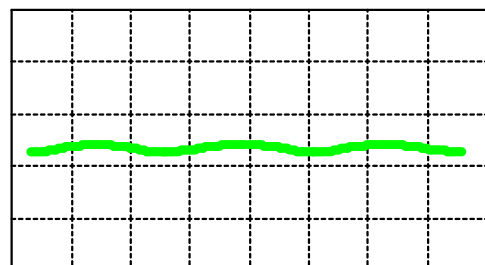
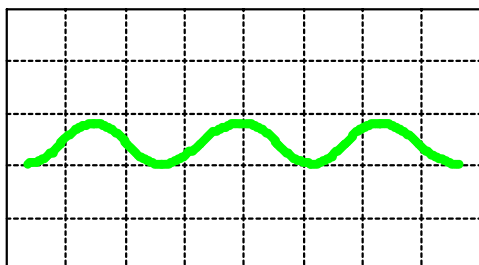
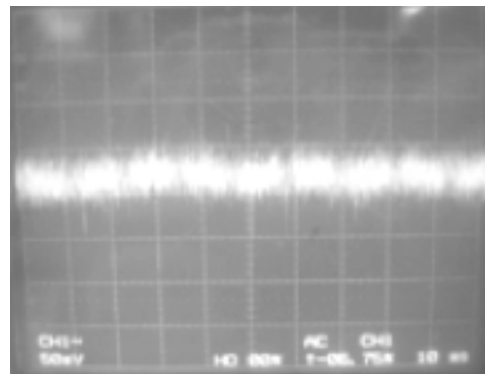
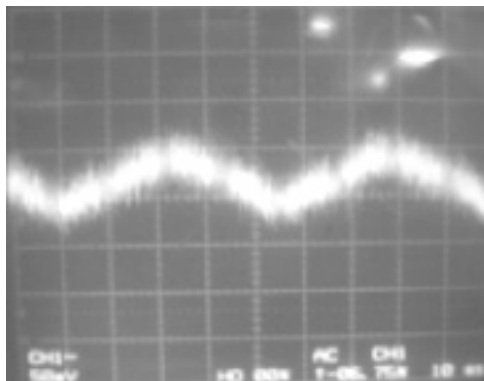

Fig. 3-2 Ass'y Deck (Top Side)

### 3-2-2 SKEW Adjustment Method

Needed to minimize the variations in Skew of the Pickup unit and to provide optimum match with the recorded signal on the Disc.

- 1) Connect an Oscilloscope to the "Pin 29 of RIC1" Test Point (See Fig. 3-1)
  - 2) Connect Power, Open the Tray and Play the Ch.14 which is in the TDV-533 Disc.
    - ◆ Set the Oscilloscope Range as follows :  
(Voltage ; 20mV/Div., Frequency ; 10m Sec.)
  - 3) Adjust the Screws "A" and "B" (See Fig. 3-2) using a Hex screwdriver until you obtain a Flat Waveform and the picture is stable.
    - Then, go to Chapter 1 and make sure the Waveform is Flat here as well.
    - If not, you have to go back to Chapter 14 and adjust again.
    - If you cannot obtain a Flat waveform, then the unit is defective.
- Note :** The Deck must be in a horizontal position. Use both "A" and "B" screws to adjust.



Typical Waveform before Adjustment

Waveform after Correct Adjustment

Fig.3-3 Envelope Waveform



---

## 4. Disassembly and Reassembly

---

### 4-1 Cabinet and PCB

---

**Note : Reassembly in reverse order.**

#### 4-1-1 Top Cabinet Removal

- 1) Remove 3 Screws ❶ the back Top Cabinet.
- 2) Lift up the Top Cabinet in direction of arrow.

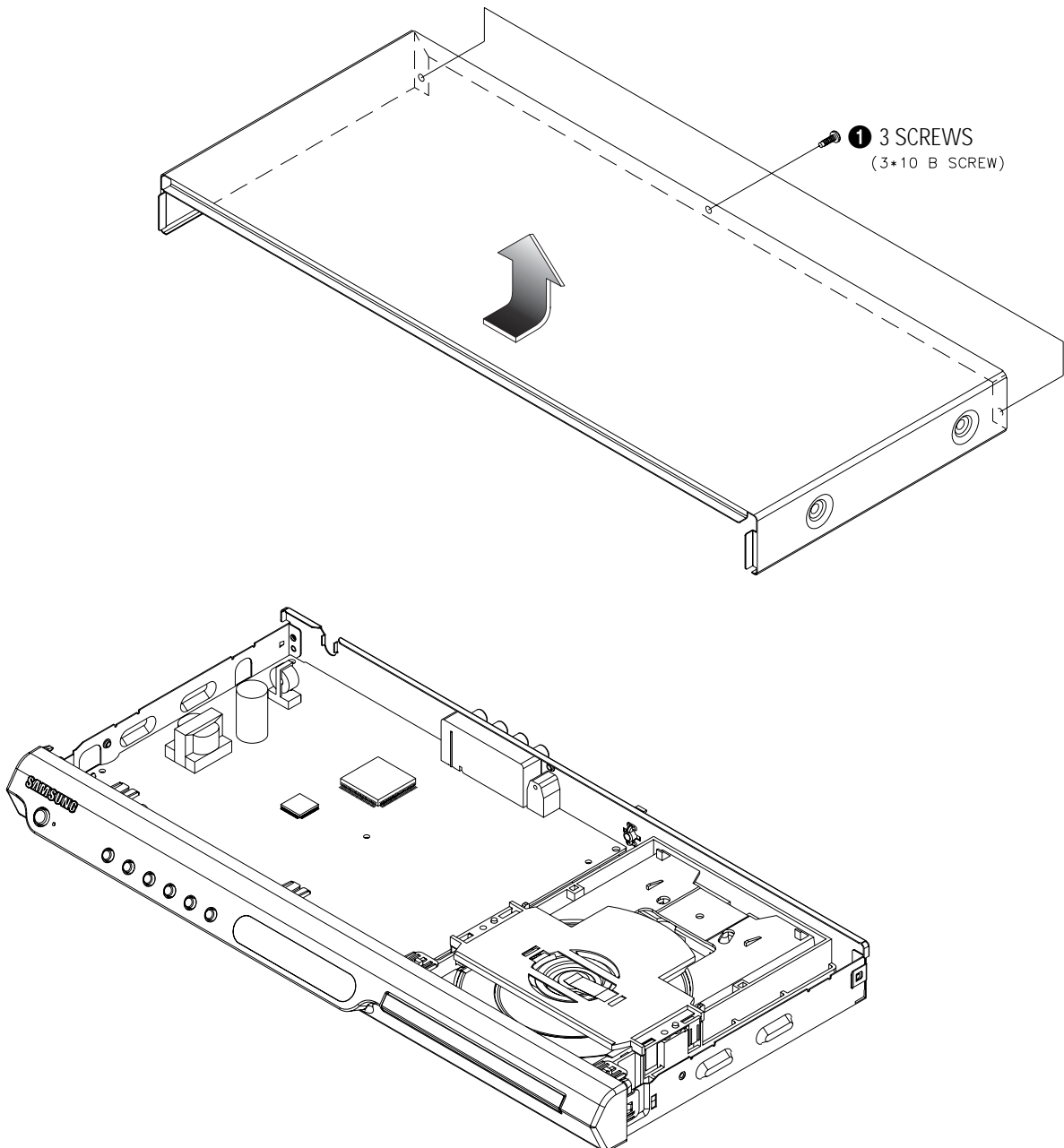

Fig. 4-1 Top Cabinet Removal

## 4-1-2 Door-Tray Removal

- 1) Supply power and open Tray ❶.
- 2) Disassemble the Door-Tray ❷ in direction of arrow "A".
- 3) Close Tray ❶ and power off.

**Note :** If Tray ❶ doesn't open, insert a Screw driver ❹ into the Emergency hole ❸ (as shown in detailed drawing) and then push it in the direction of arrow "B". Open Tray manually.

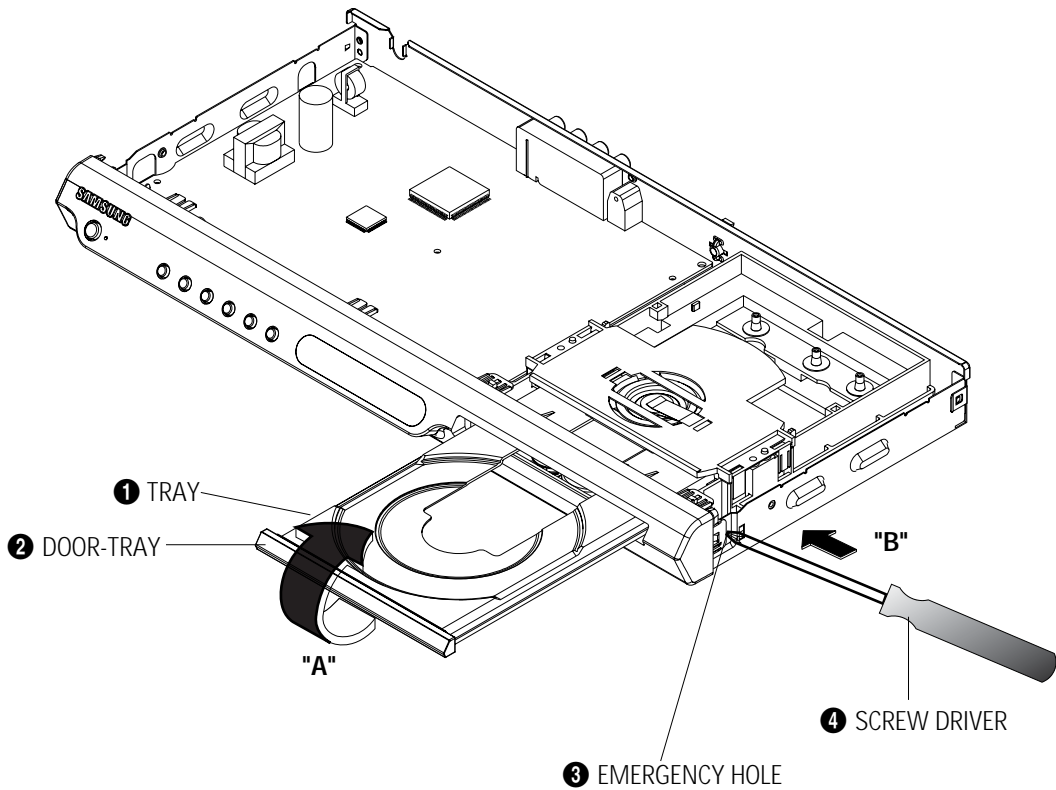

Fig. 4-2 Door-Tray Removal

### 4-1-3 Ass'y Front-Cabinet Removal

1) Release 6 Hooks ①, ②, ③, ④ and Remove the Ass'y Front-Cabinet ⑤.

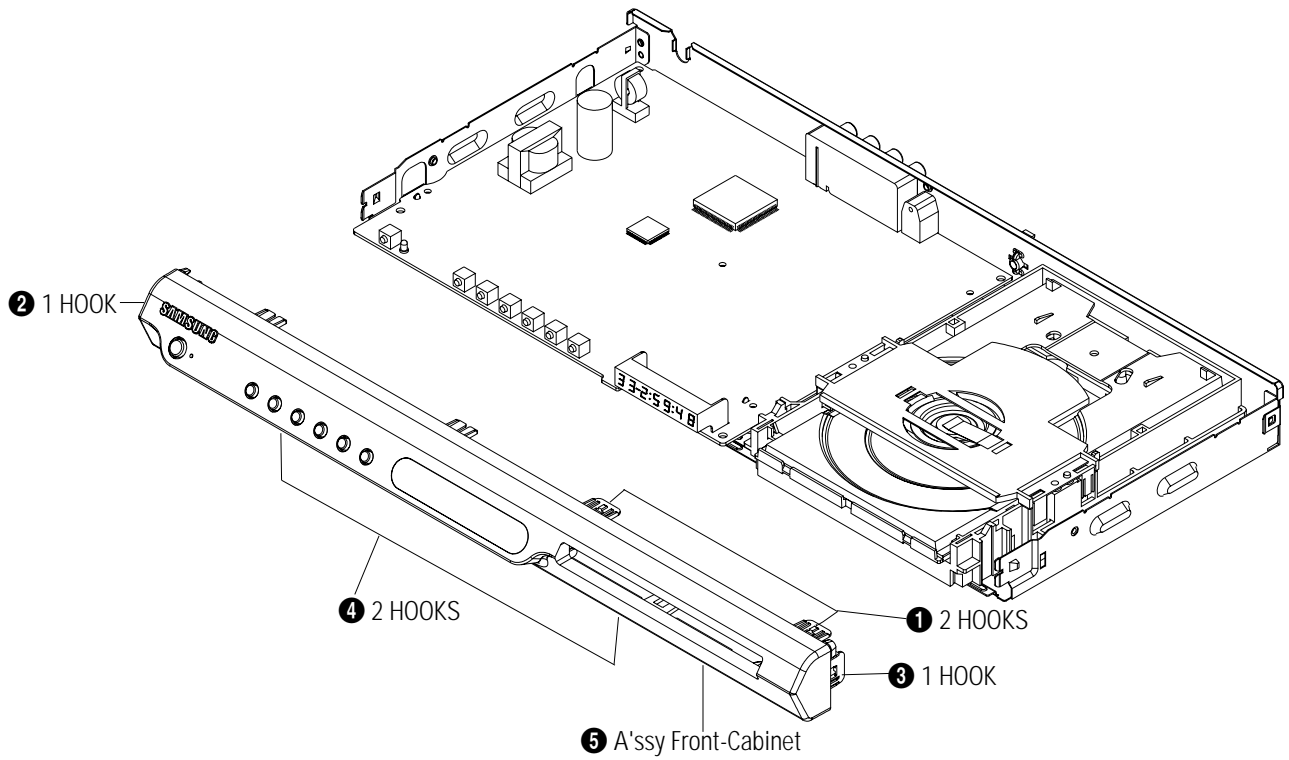

Fig.4-3 Ass'y Front-Cabinet Removal

#### 4-1-4 Ass'y Deck Removal

- 1) Disconnect Flat-Cable from DCN1, DCN2 on Main PCB.
- 2) Remove 3 Screws ❶ from the Ass'y Deck and lift it up.

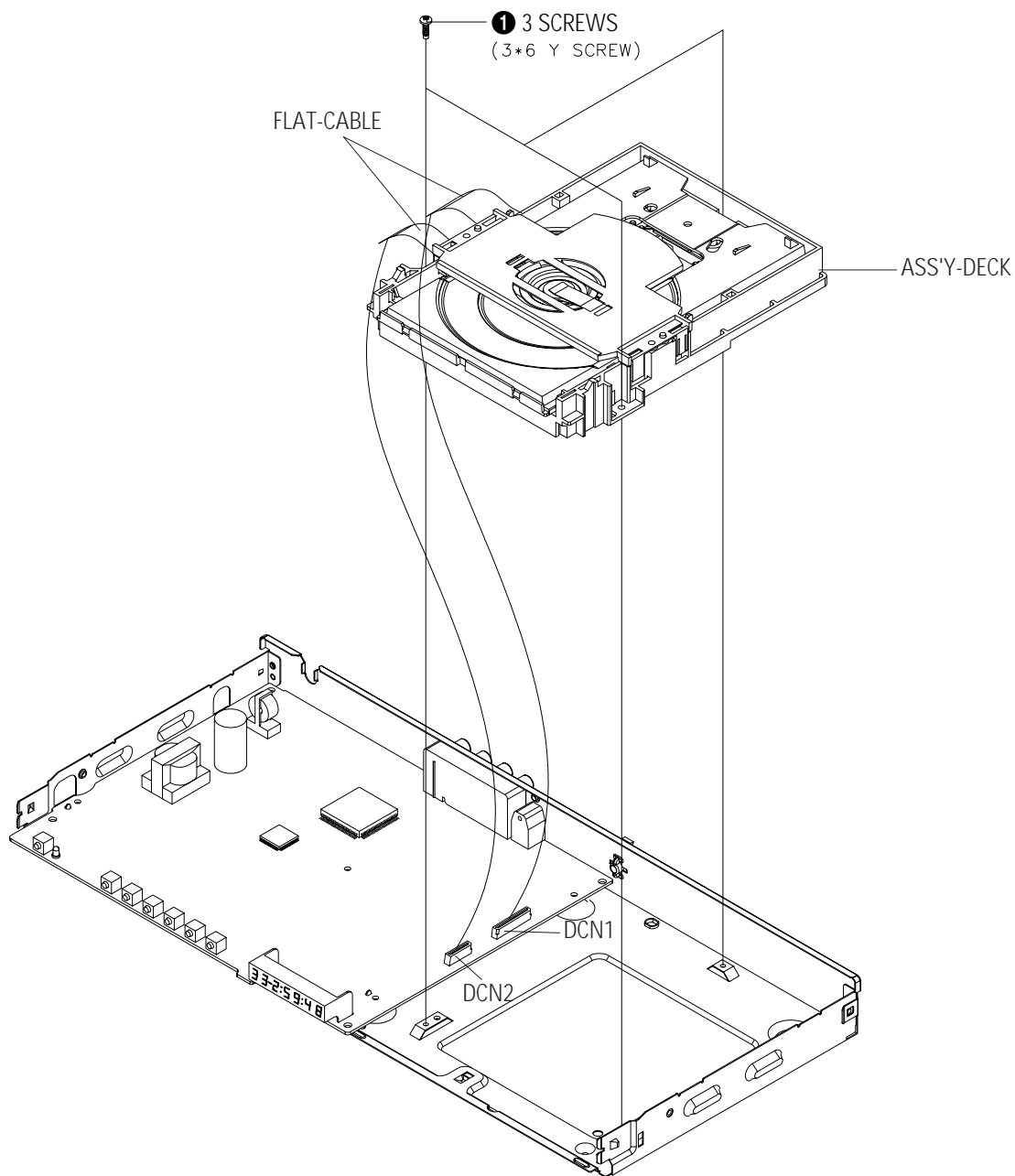

Fig. 4-4 Ass'y Deck Removal

## 4-1-5 Main PCB Removal

- 1) Remove 4 Screws ❶.
- 2) Lift up the Main PCB ❷.

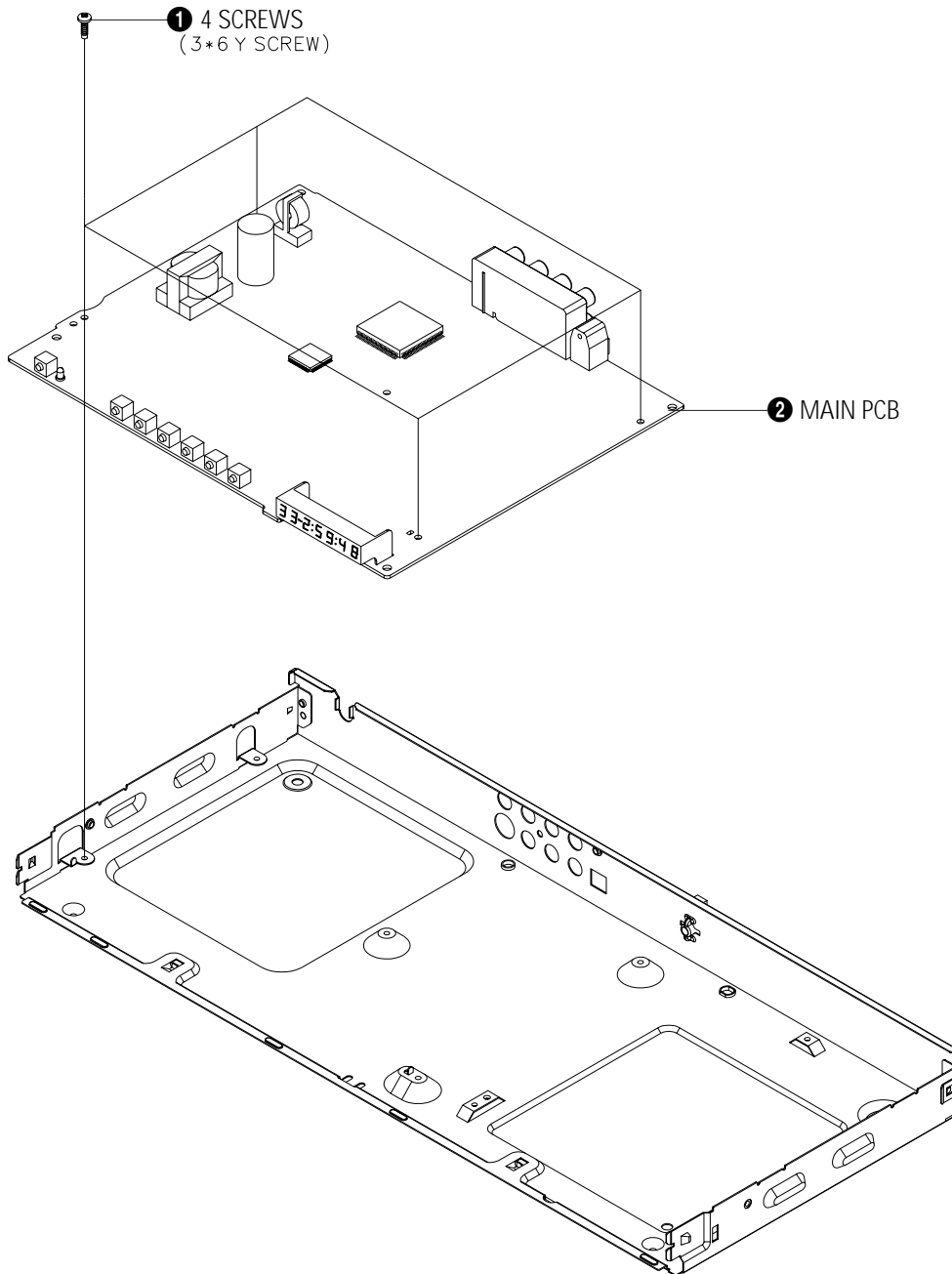

Fig. 4-5 Main PCB Removal

## 4-2 Deck

### 4-2-1 Holder Chuck Removal

- 1) Push 4 Hooks ❶ in the direction of arrow "A" and lift up the Holder Chuck ❷.

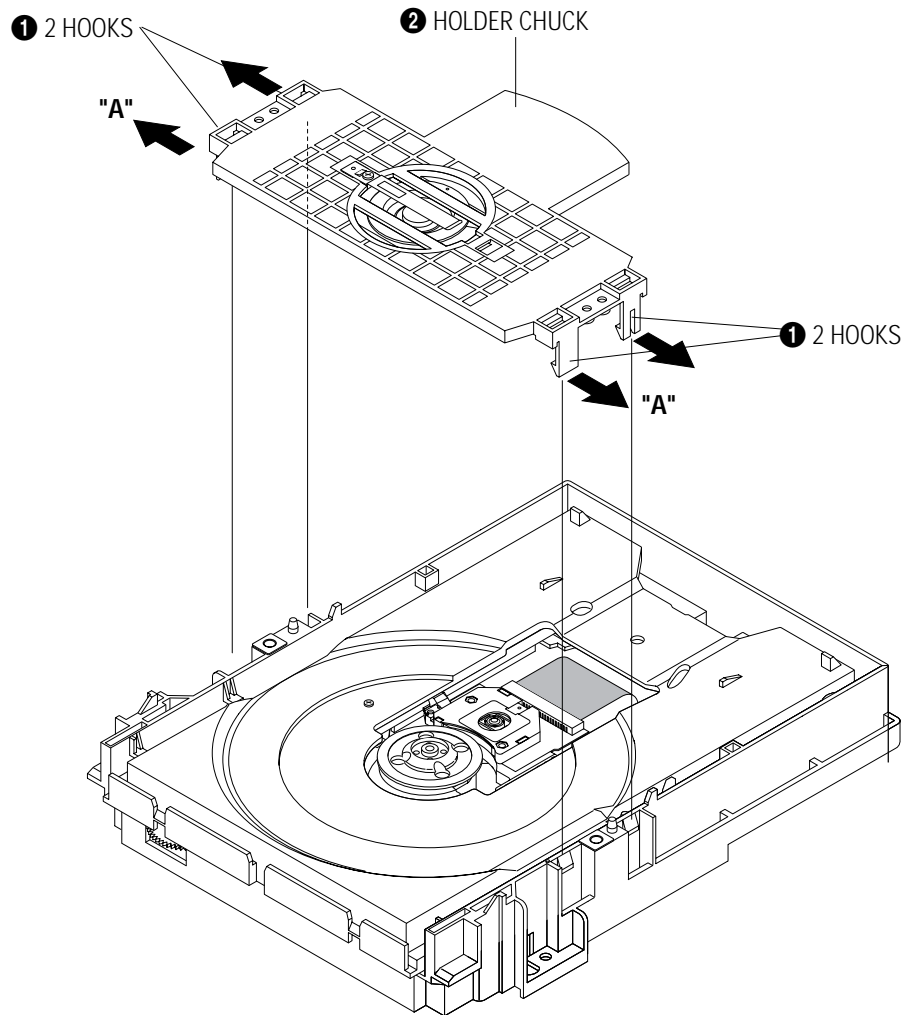

Fig. 4-6 Holder Chuck Removal

## 4-2-2 Tray Disc Removal

- 1) Insert a Screw Driver **1** into Emergency Hole **2** and push the Slider Housing **3** in the direction arrow "A".
- 2) When the Tray Disc **4** comes out a little, pull it in the direction arrow "B" by hand.

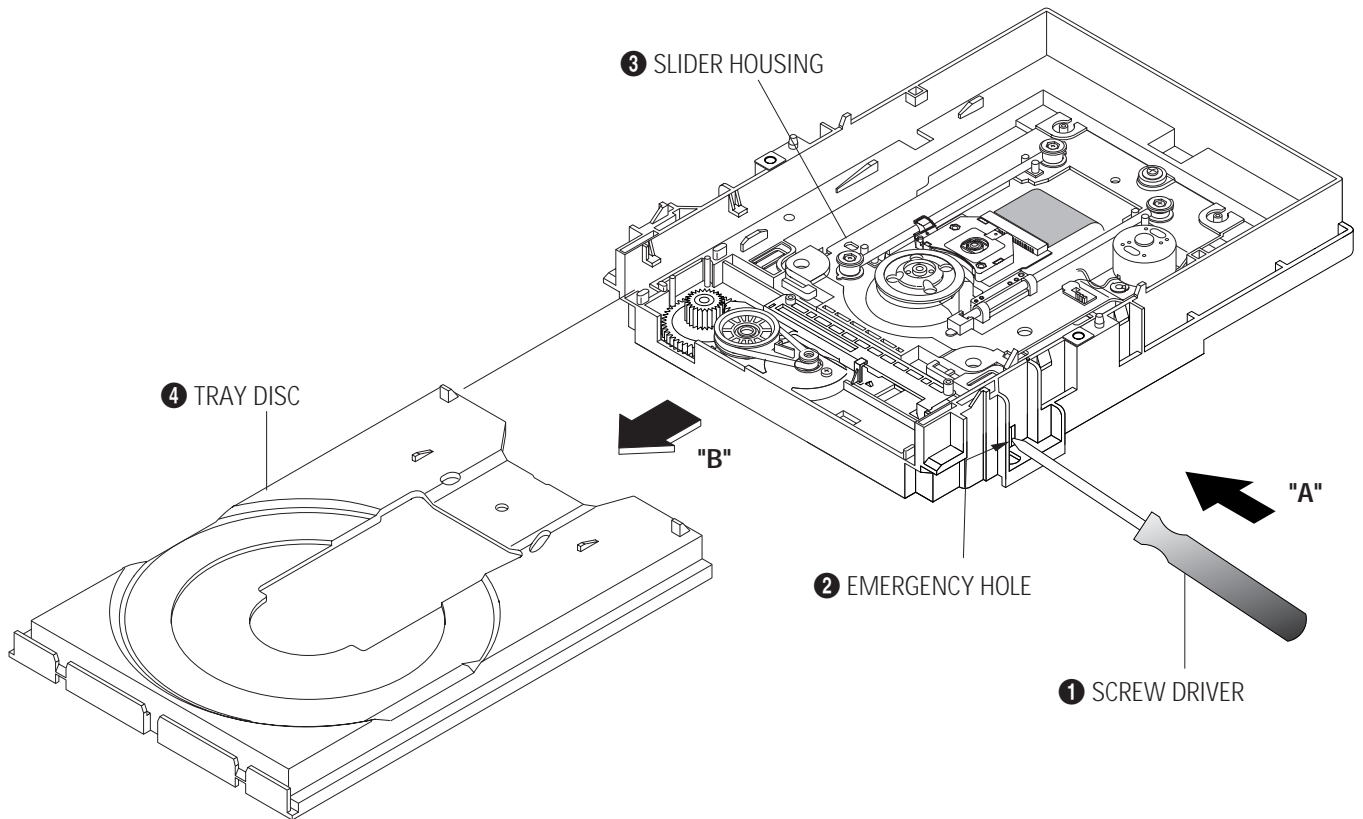

Fig.4-7 Tray Disc Removal

### 4-2-3 Assy P/U Deck Removal

- 1) Remove the 4 Soldering ❶ (SL+, SL-, SP+, SP-).
- 2) Remove the 1 Screw ❷ and lift up the Ass'y P/U Deck ❸

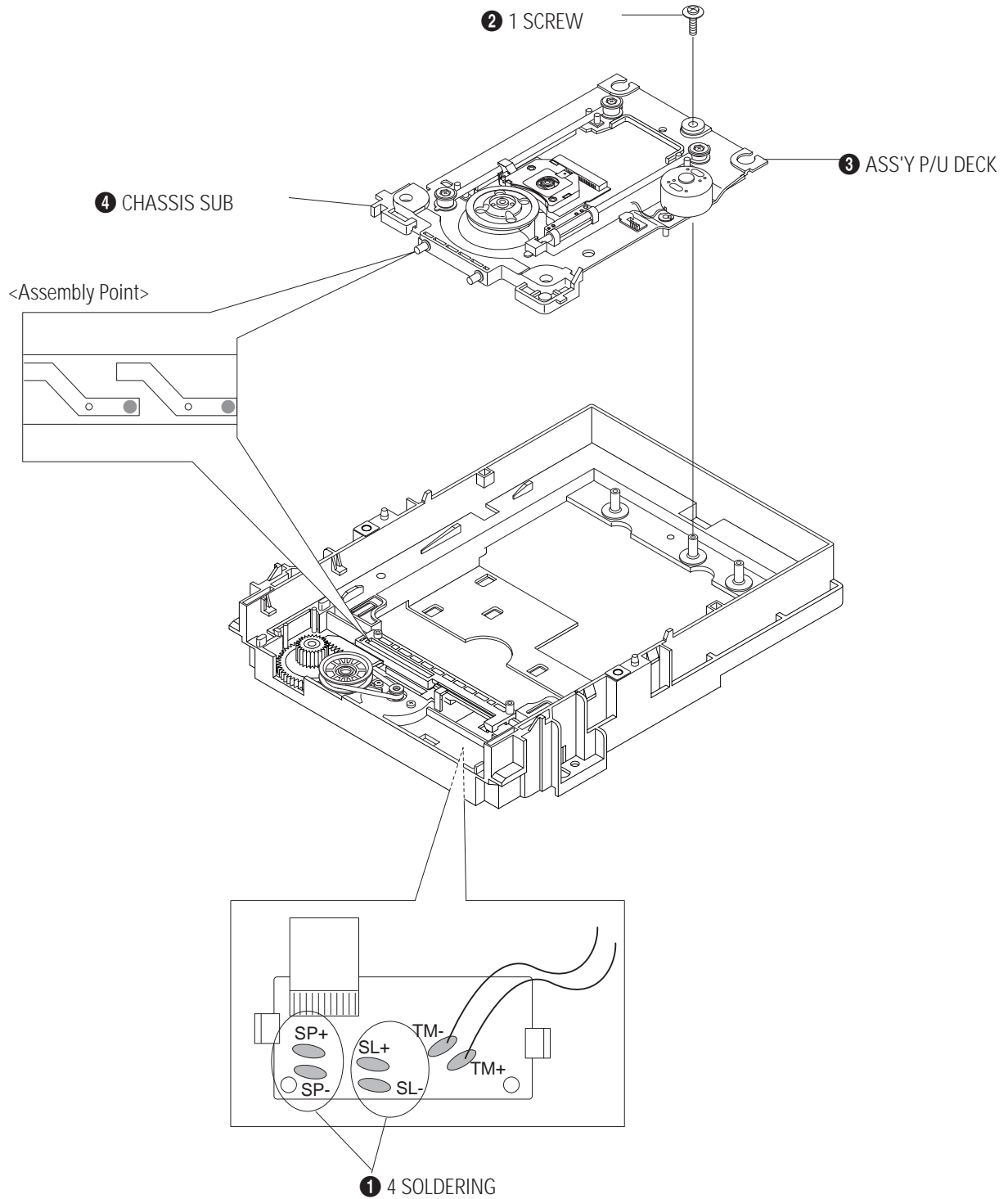

Fig. 4-8 Assy P/U Deck Removal



## 4-2-4 Ass'y Housing Removal

- 1) Remove the 2 Soldering ❶. (TM+, TM-)
- 2) Push the 2 Hooks ❷ in the direction of arrow "A" and remove Ass'y PCB Deck ❸.
- 3) Push the Slider Housing ❹ in the direction arrow "B".
- 4) Push the 1 Hook ❺ in the direction of arrow "C" and lift up the Slider Housing ❹.
- 5) Remove the Belt Pulley ❻ and 2 Screws ❼, Ass'y Motor Load ❽.
- 6) Push the 1 Hook ❾ in the direction of arrow "D" and lift up the Gear Pulley ❿, Gear Tray ⓫.

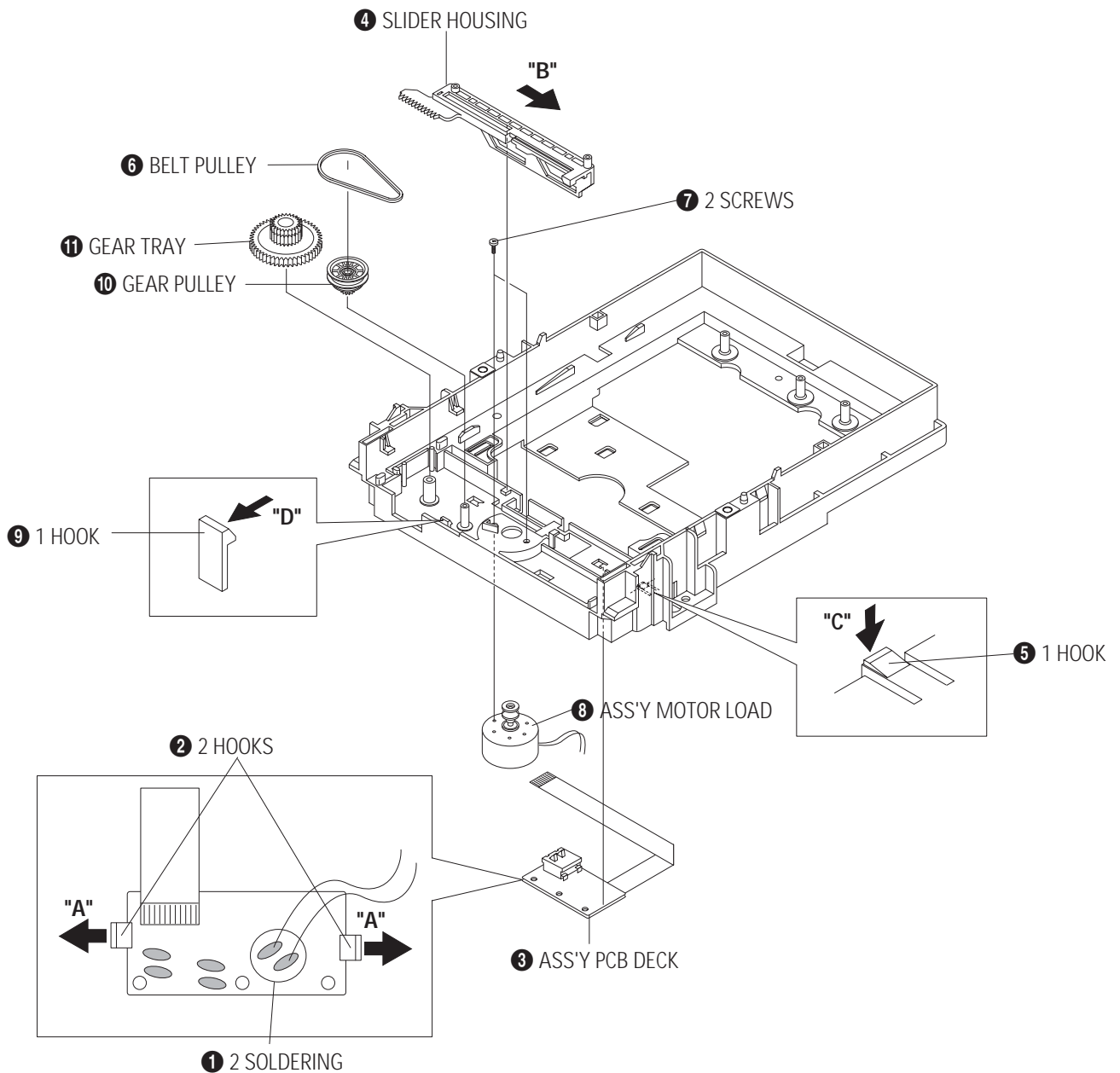

Fig. 4-9 Ass'y Housing Removal

### 4-2-5 Ass'y Bracket Deck Removal

- 1) Push the Hook ① in the direction of arrow "A" and lift up the Gear Feed B ②.
- 2) Push the Hook ③ in the direction of arrow "B" and lift up the Gear Feed A ④.
- 3) Remove the 2 Screws ⑤ and lift up Motor Feed Ass'y ⑥.
- 4) Remove the 2 Screws ⑦ and lift down Motor Spindl Ass'y ⑧.
- 5) Remove the 3 Screws ⑨ and remove 3 Holder Cam Skew ⑩, Shaft Pick Up ⑪, Ass'y Pick Up ⑫.
- 6) Remove the 1 Screws ⑭ and remove Gear Back Lash ⑮.

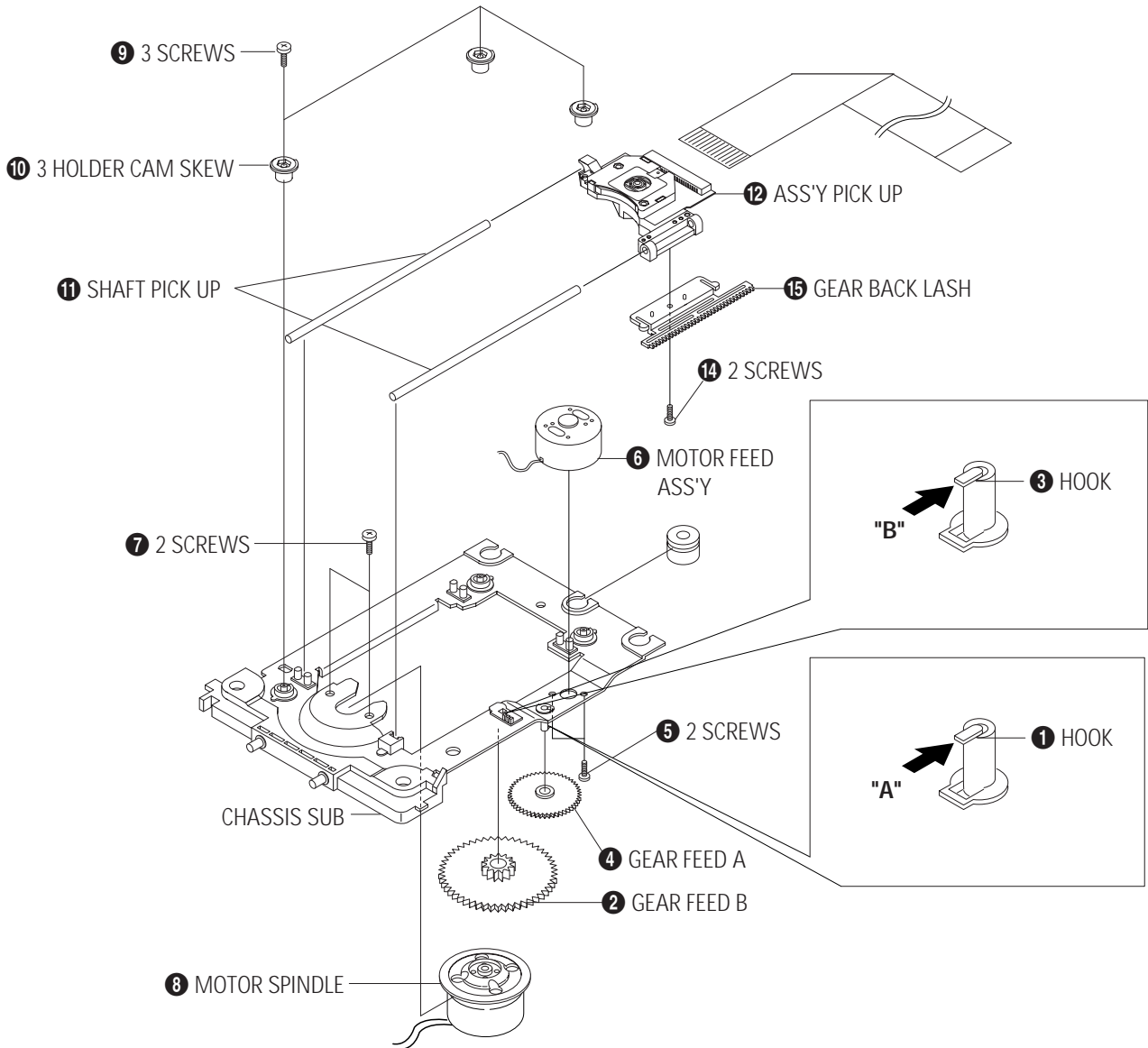
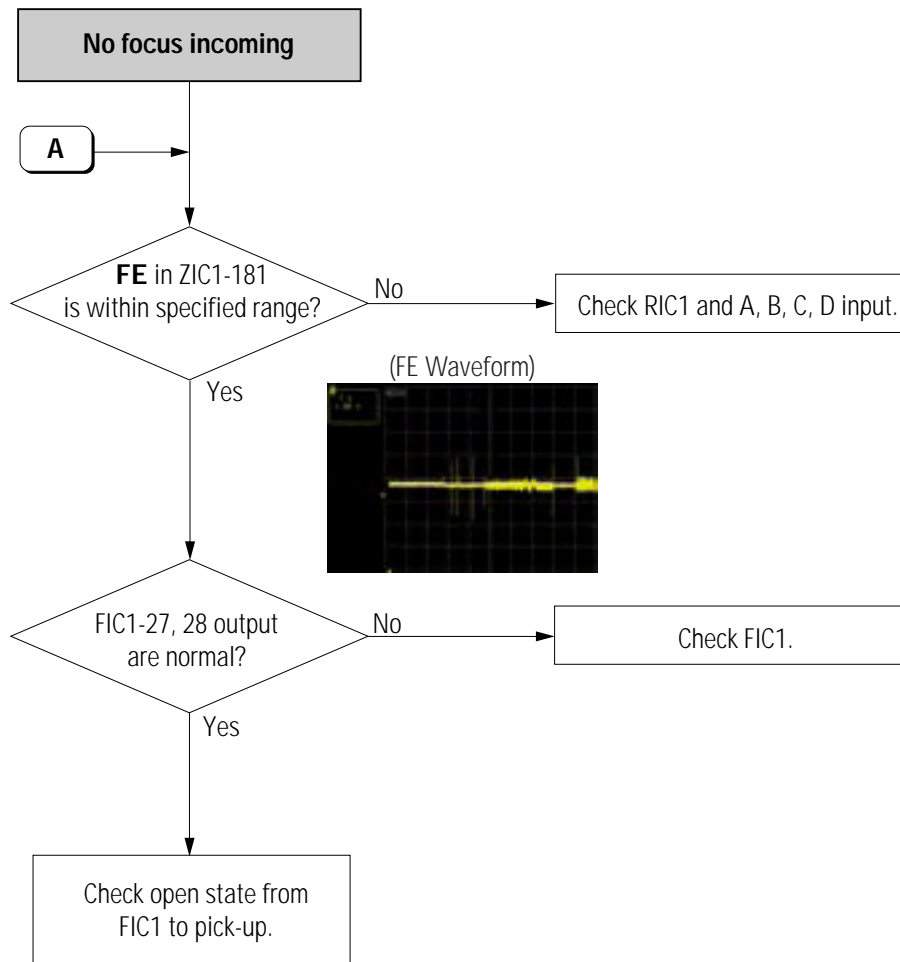
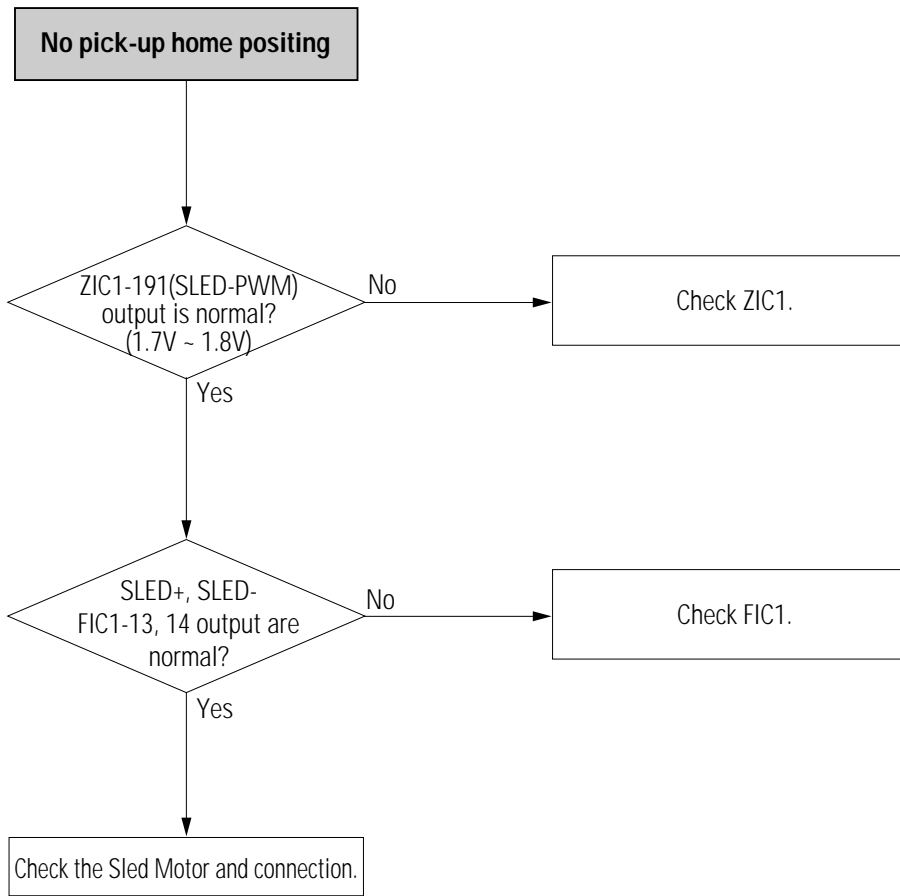
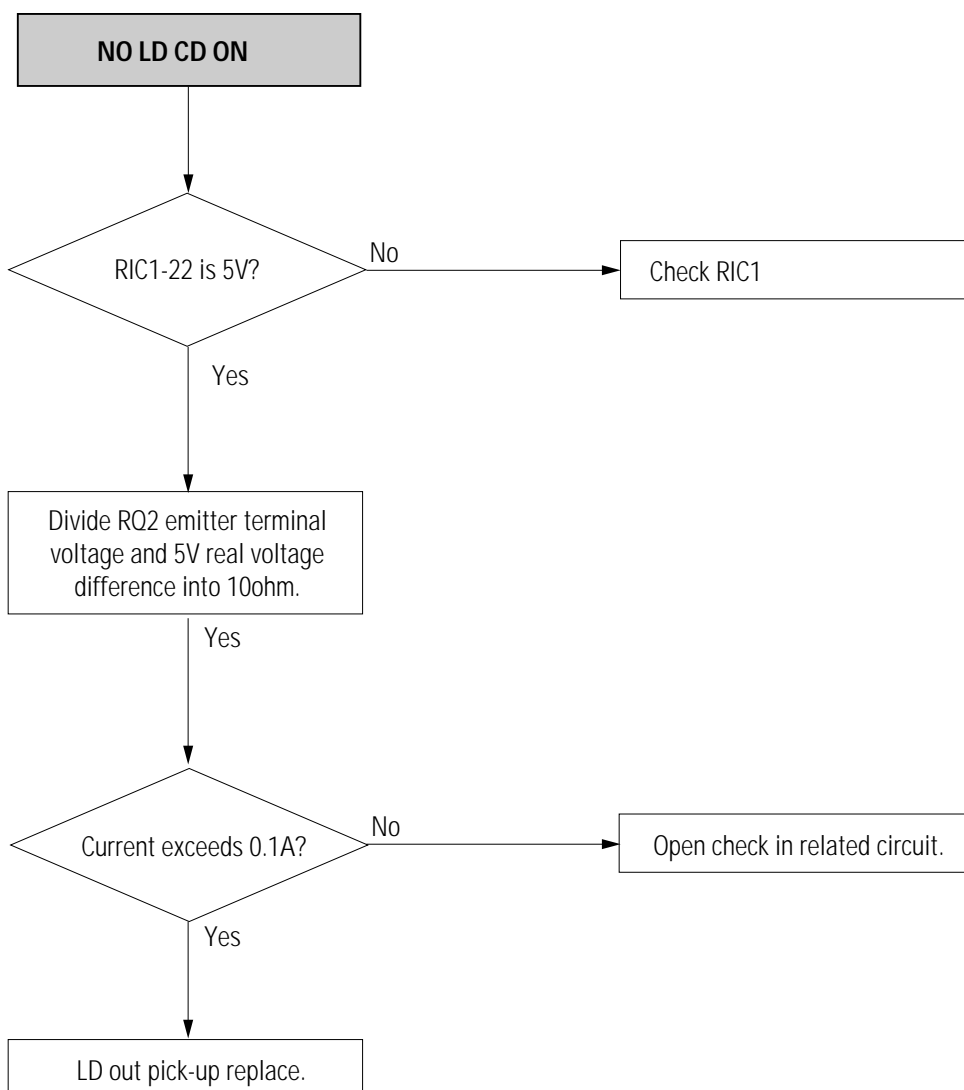

Fig. 4-10 Ass'y Bracket Deck Removal

## 5. Troubleshooting







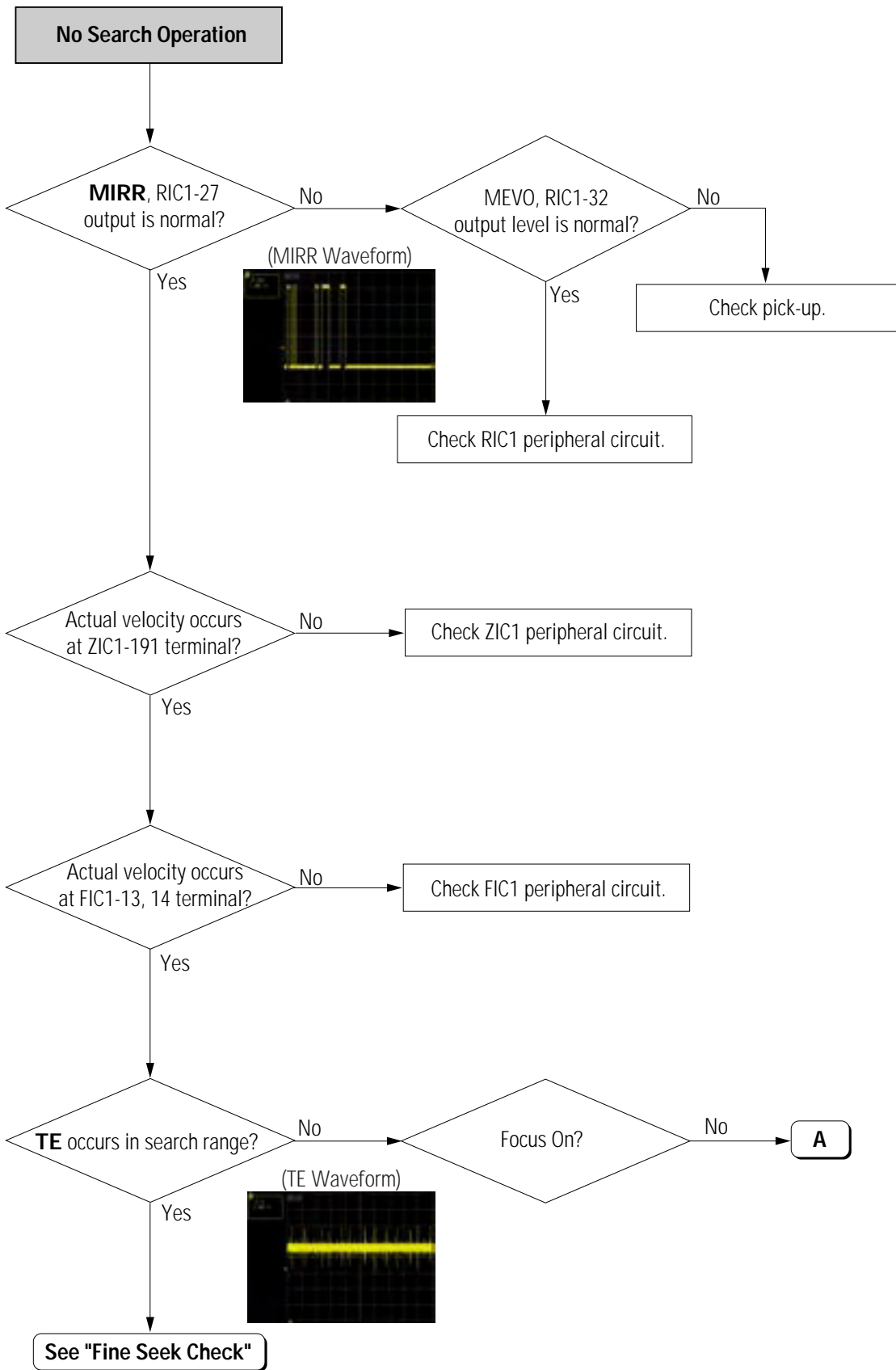

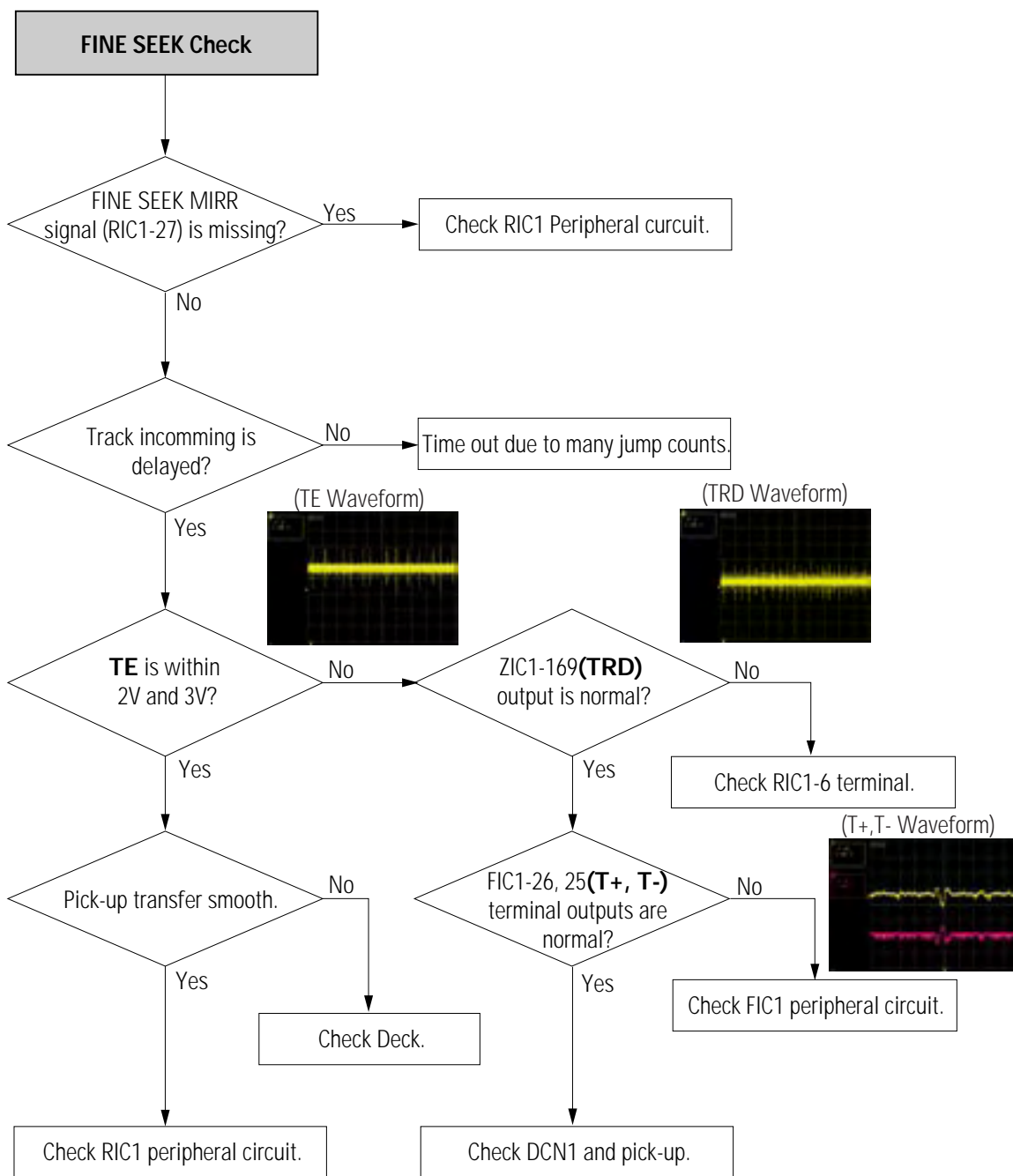

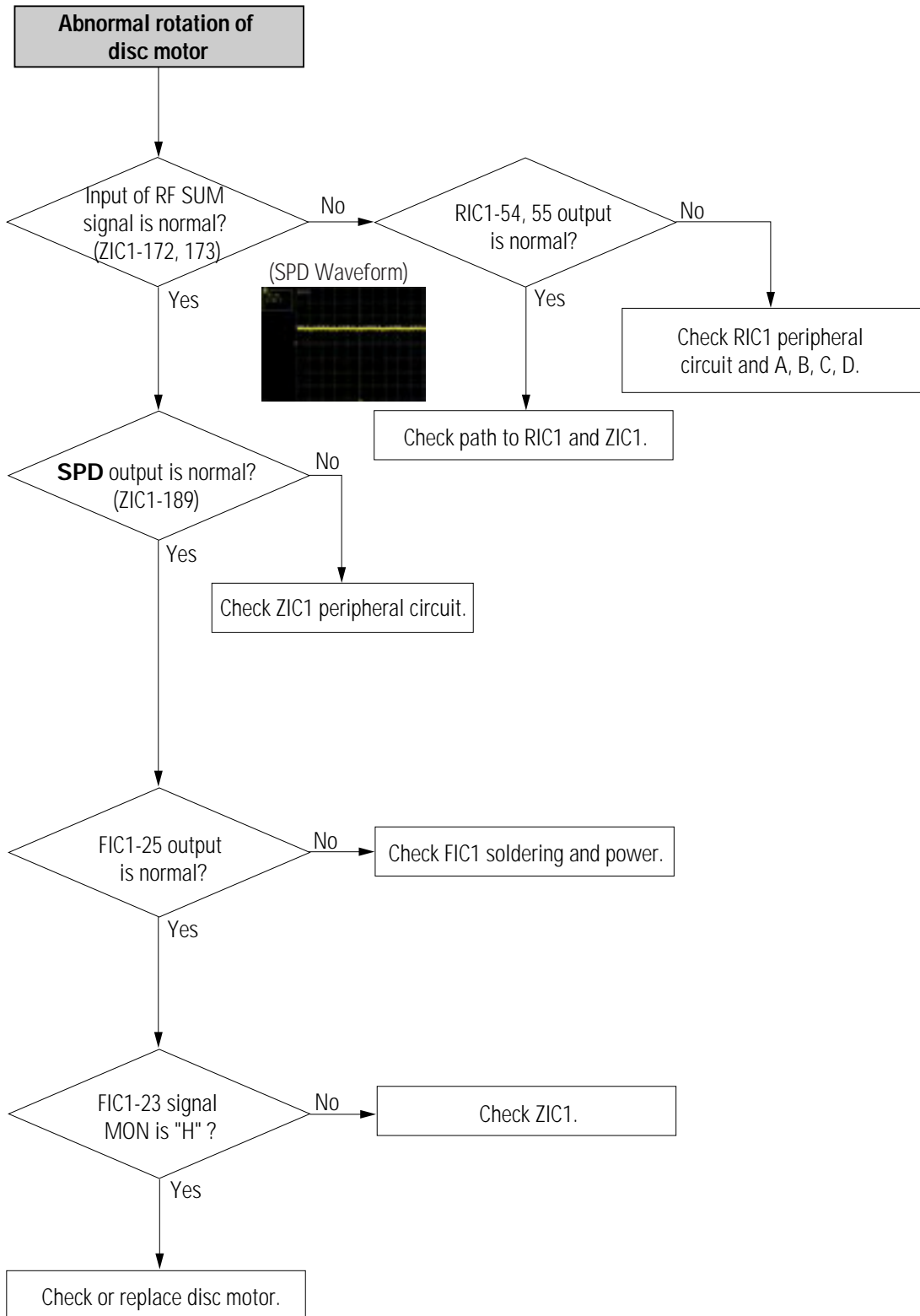



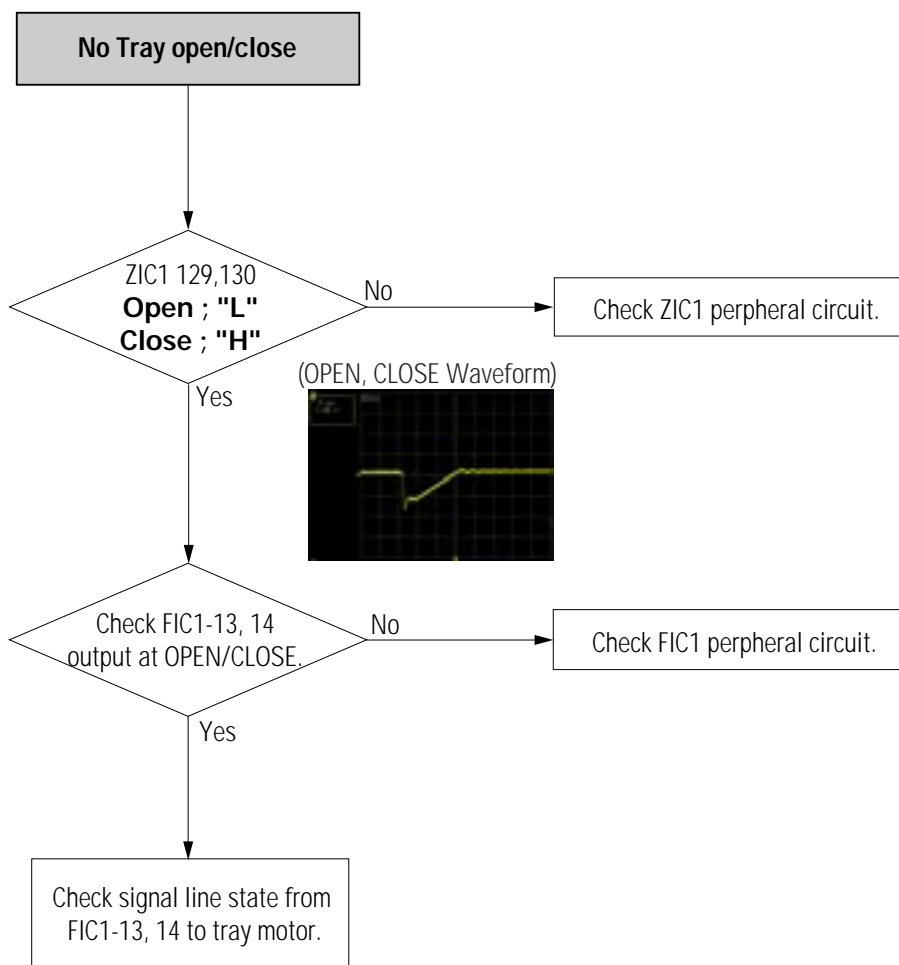

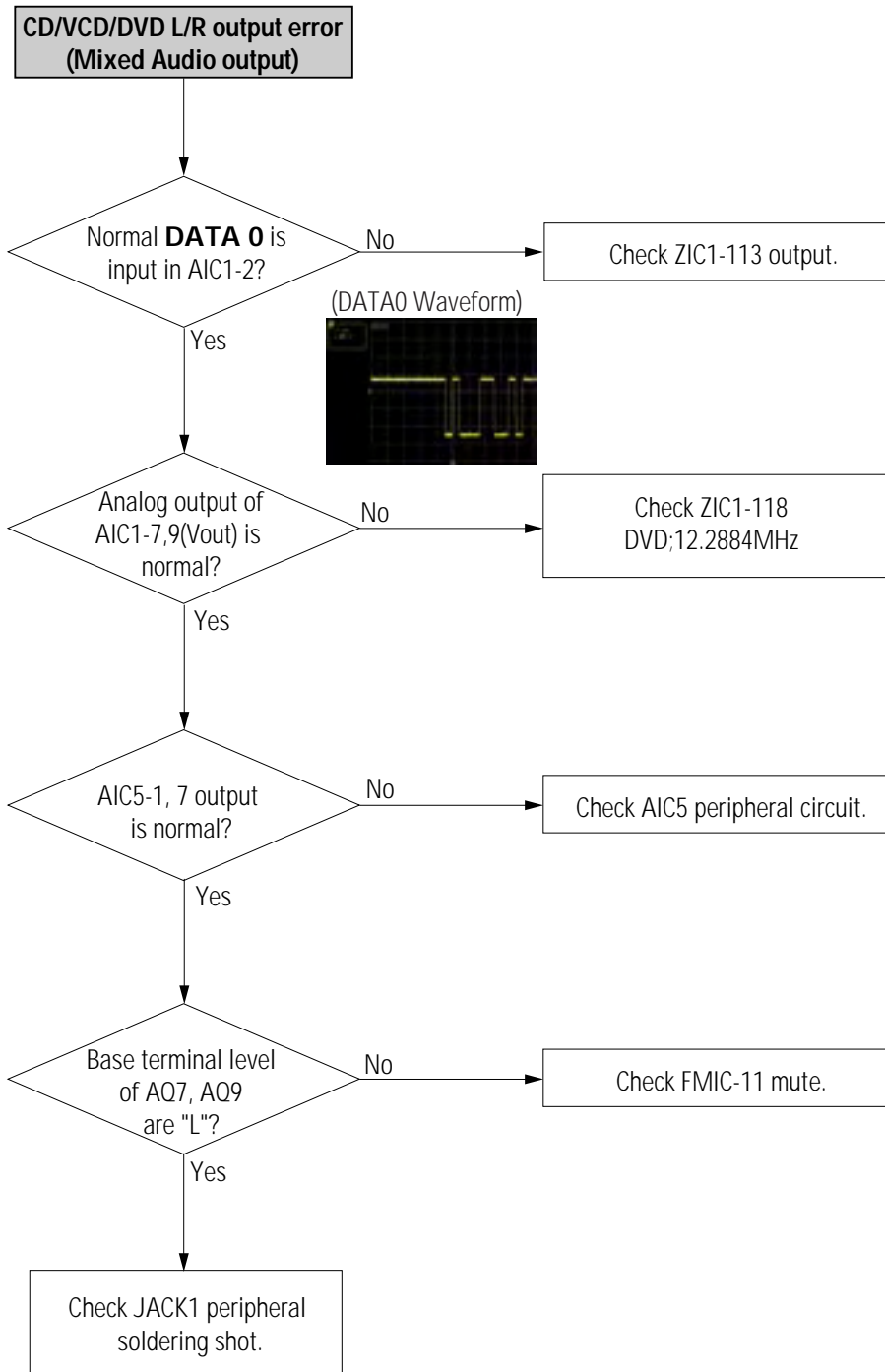

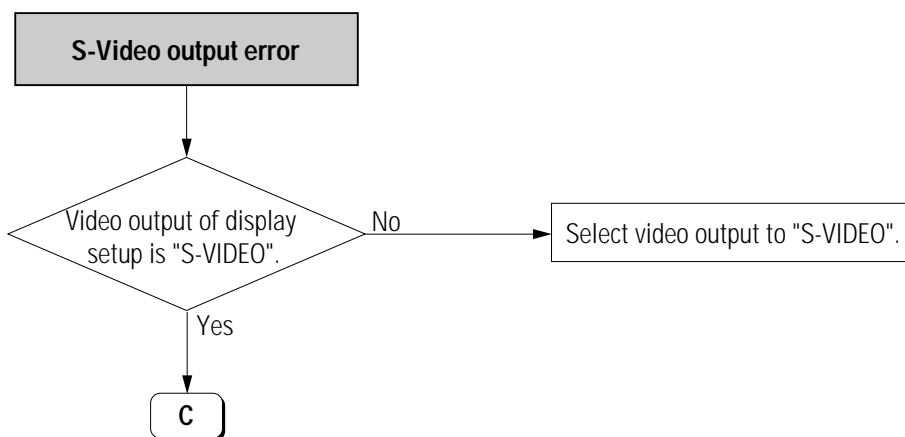

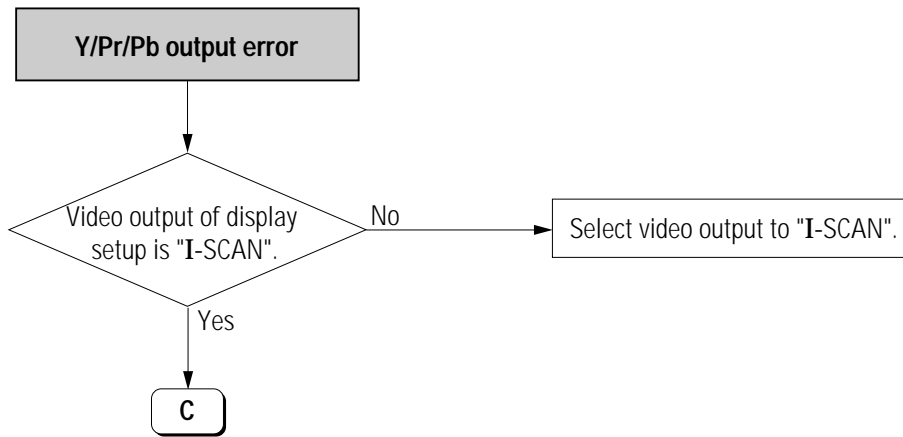

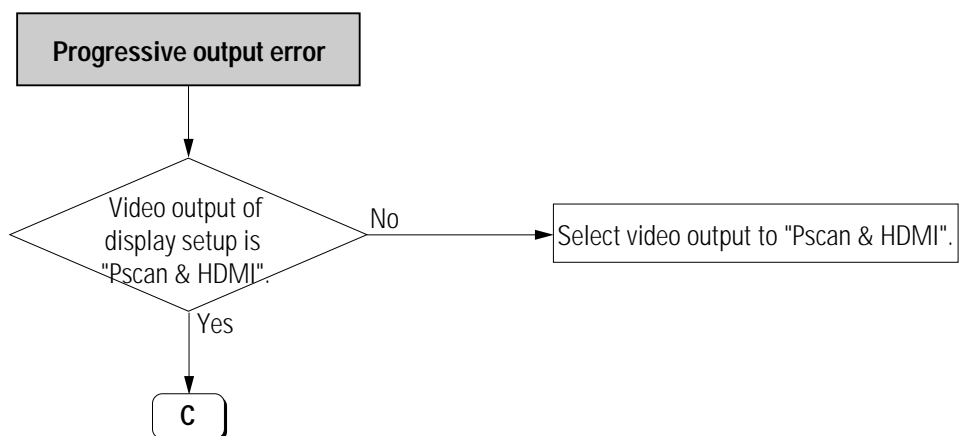

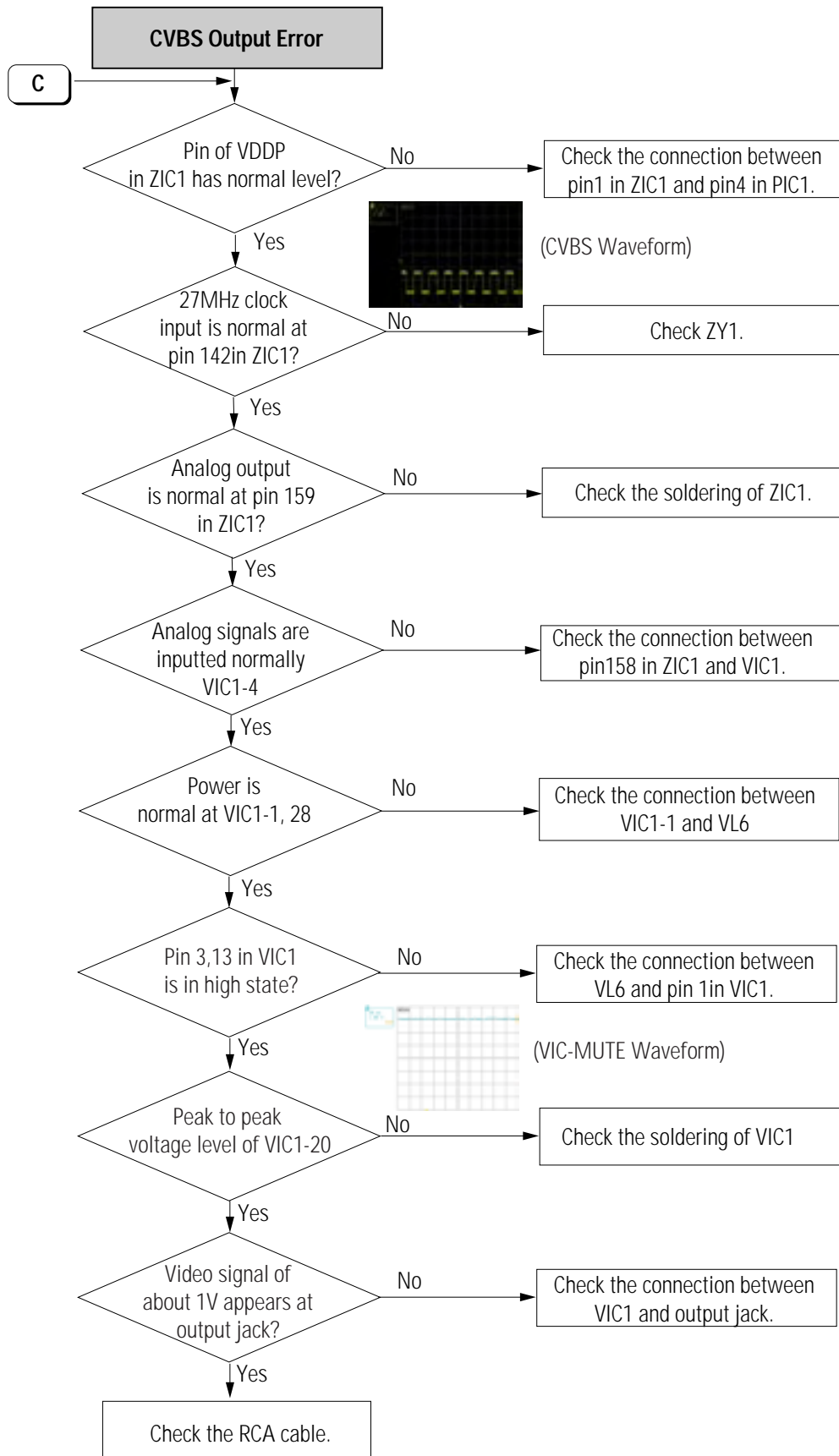

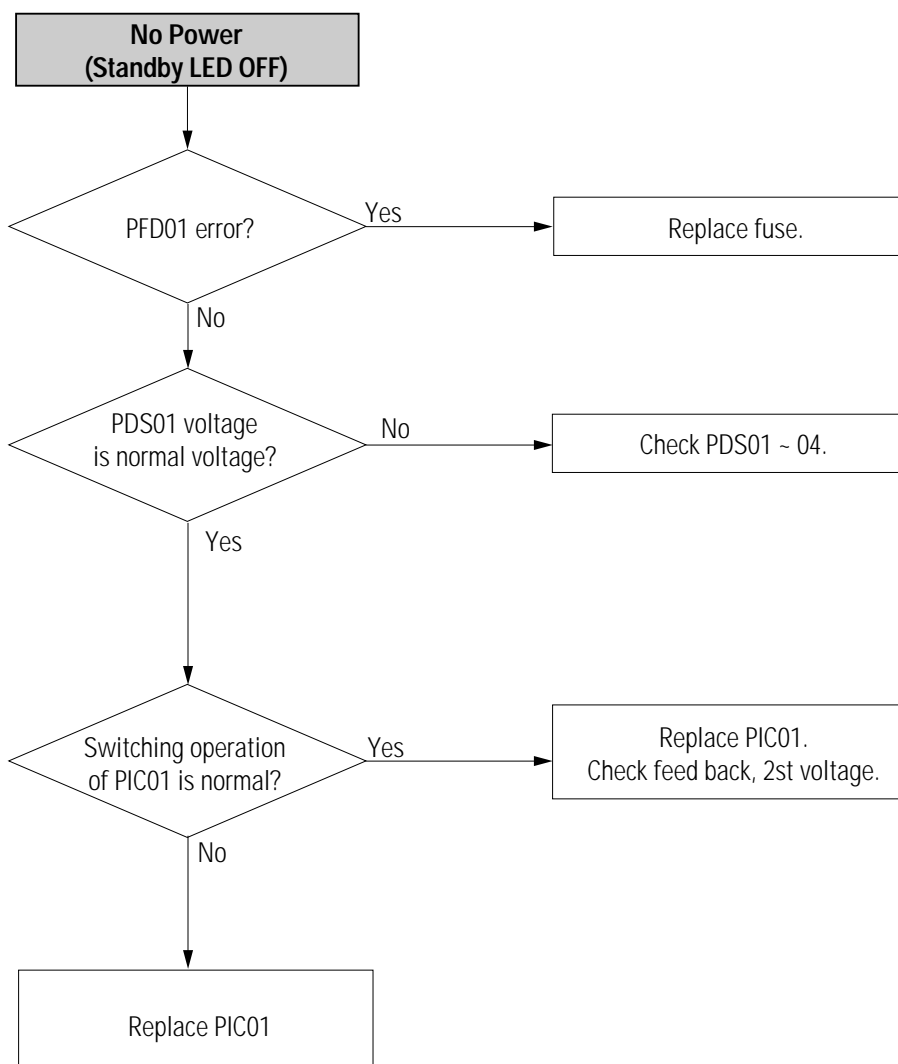

---

## 6. Exploded View and Parts List

---

6-1 Cabinet Assembly	-----	6-2
6-2 DVD Mechanical Parts	-----	6-4



## 6-1 Cabinet Assembly

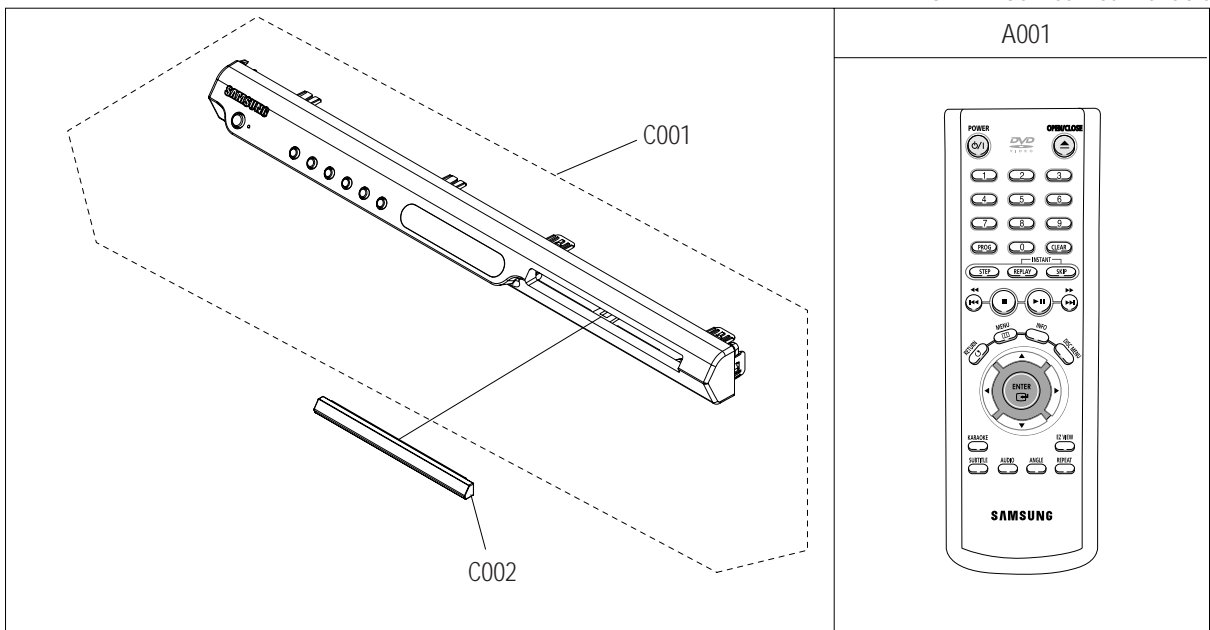
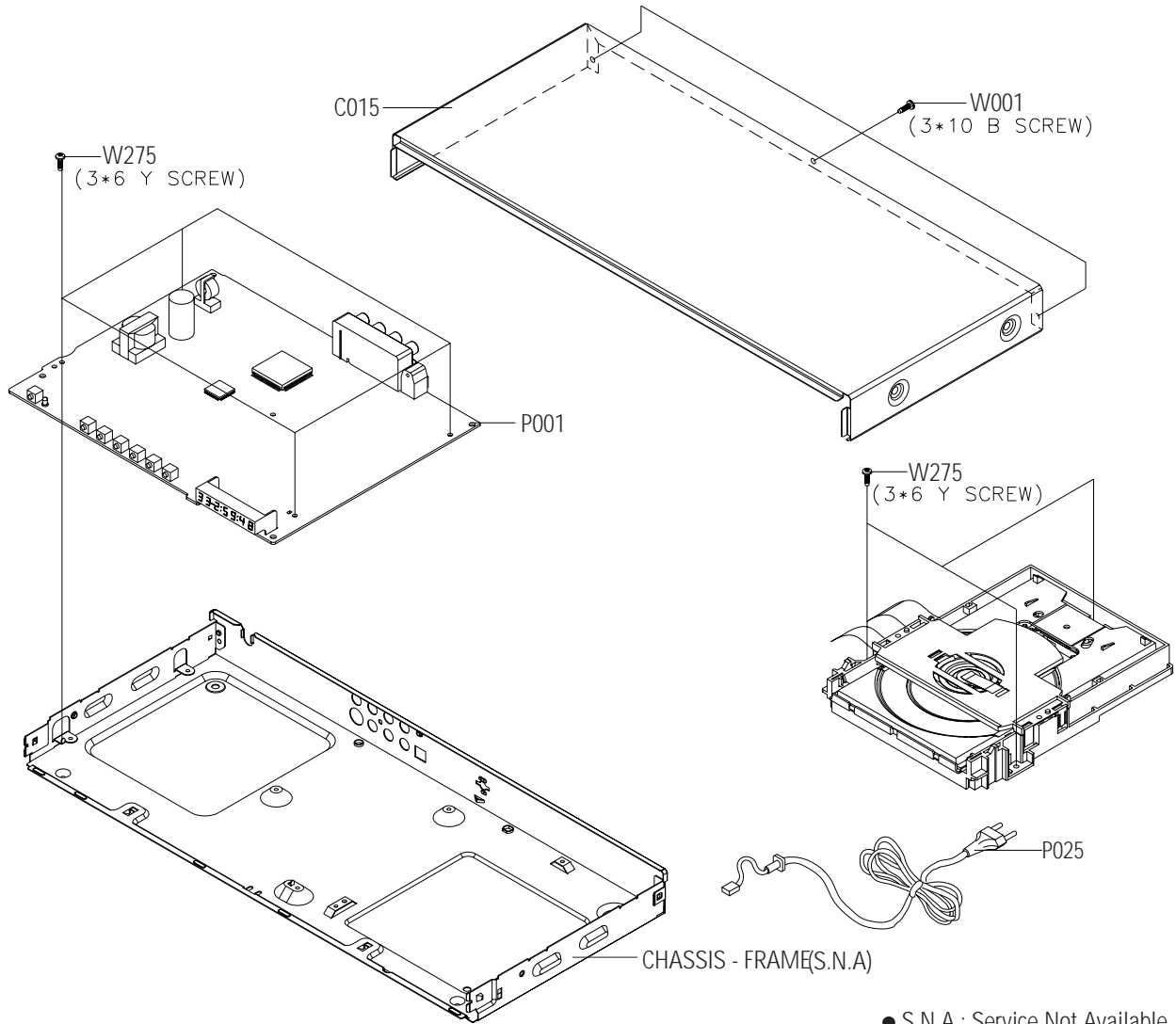

Loc. No	Parts No.	Description ; Specification	Q'ty	S.N.A	Remark
A001	AK59-00011J	REMOCON-ASSY;DVD-P241/XAA,XAA,-,-,36,-,-	1	SA	
C001	AK97-01225E	ASSY CABINET-FRONT;HIPS 94 HB,DVD-P355B/	1	SA	
C002	AK64-01189C	DOOR-TRAY;DVD-P355B/XEL,SEIN,ABS 94 HB,T	1	SA	
C015	AK97-01103D	ASSY CABINET-TOP;PCM T0.55,DVD-P355B/XE	1	SA	
P001	AK92-00680B	ASSY PCB-MAIN;DVD-P355/XEV,MAIN PCB ASSY	1	SA	CIS Only
	AK92-00680A	ASSY PCB-MAIN;DVD-P355/XEO,MAIN PCB ASSY	1	SA	Other Only
P025	AC39-12022K	CBF-POWER CORD;AT,,GP2,HOUING(2P),250V,3	1	SA	U.K Only
	AC39-10019A	CBF-POWER CORD;KKP-419C,H03VVH2-F,VDE/KE	1	SA	Other Only
W001	6003-000275	SCREW-TAPTITE;BH,+ ,B,M3,L10,BLK ,SWCH101	4	SA	
W275	6003-001561	SCREW-TAPTITE;BH,+ ,WT,B,M3,L6,ZPC(YEL),S	7	SA	

## 6-2 DVD Mechanical Parts

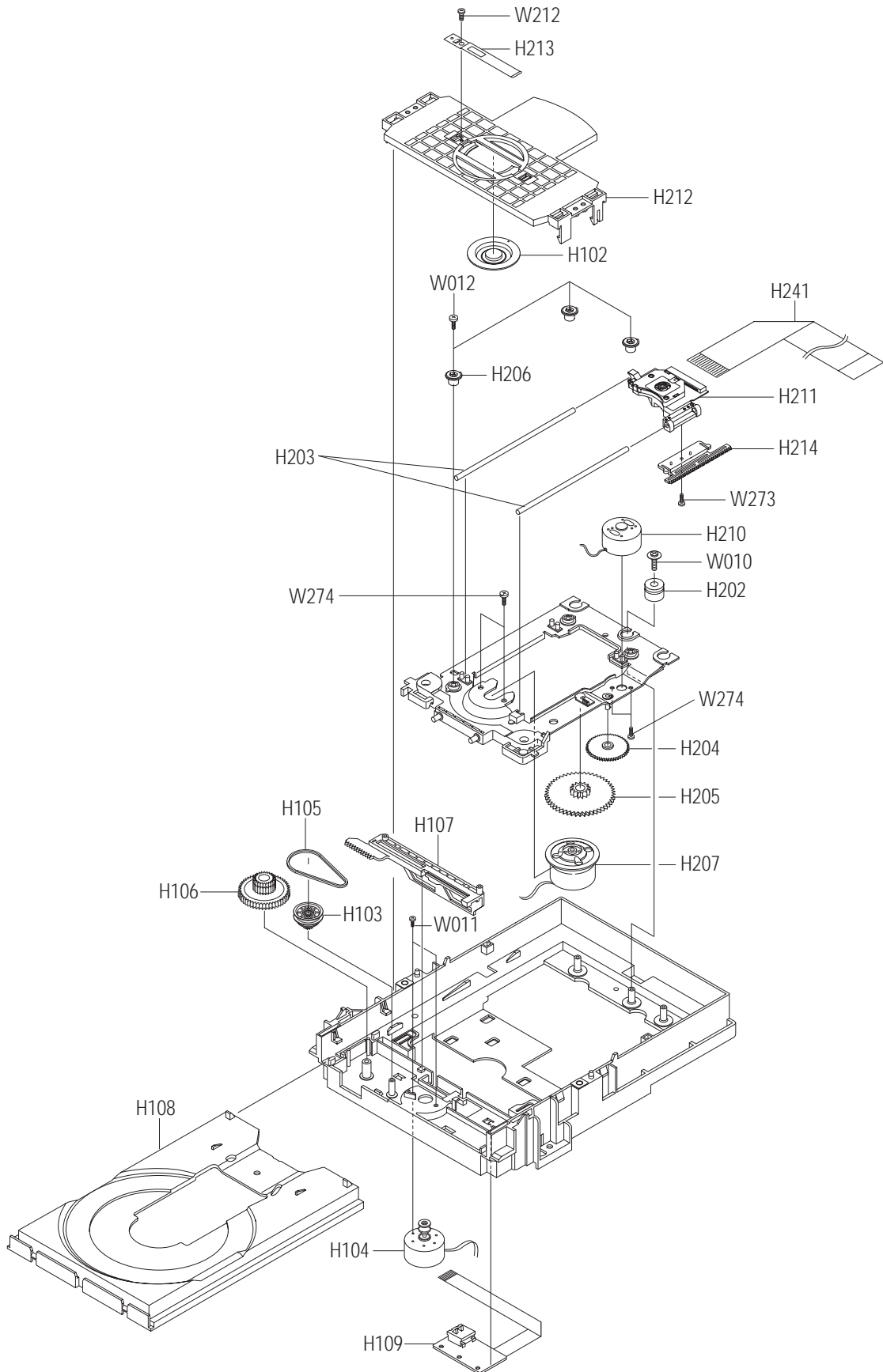

Loc. No	Parts No.	Description ; Specification	Q'ty	S.N.A	Remark
H102	AK61-00360A	BODY CLAMPER-DISC;DP-16,POM,T0.7,-,-,-,W	1	SA	
H103	AK66-00042A	GEAR-PULLEY;DP-15,POM,-,-,-,WHT,-,-,-	1	SA	
H104	AK97-00608A	ASSY-MOTOR LOAD;-,-,DP-15,-	1	SA	
H105	6602-001076	BELT-RECTANGULAR;CR,T1.2,4.3%,1.2X25.1,B	1	SA	
H106	AK66-00041A	GEAR-TRAY;DP-15,POM,-,-,-,WHT,-,-,-	1	SA	
H107	AK66-00045A	SLIDER HOUSING;DP-15,POM,-,W17.8,L90,WHT	1	SA	
H108	AK63-00101C	TRAY-DISC;DP-16,ABS,-,W120,L186.3,-,BLK,	1	SA	
H109	AK92-00328C	ASSY PCB-DECK;DP-15,COMBO-A	1	SA	
H202	AK73-00005B	RUBBER-INSULATOR;DP-15,BUTYL,•'12,HS30,H	1	SA	
H203	AH61-50327A	SHAFT-P/U;DP-3,SUS,L84.7,OD3,-,-,-	2	SA	
H204	AK66-00043A	GEAR-FEED A;DP-15,POM,-,-,-,-,-,-,-	1	SA	
H205	AK66-00044A	GEAR-FEED B;DP-15,POM,-,-,-,-,-,-,-	1	SA	
H206	AK61-00363A	HOLDER-CAM SKEW;DP-16,POM,-,-,-,BLK,-	3	SA	
H207	AK31-00017A	MOTOR DC-SPINDLE;RF300FA-12350,DP-17,-,-	1	SA	
H210	AK31-00005A	MOTOR-FEED ASSY;-,-,DP-9,-,-,-,-,-,-,-,-	1	SA	
H211	AK97-01009B	ASSY-PICK UP;-,-,DP-16,MITSUMI VE	1	SA	
H212	AK61-00359A	HOLDER-CHUCK;DP-16,POM,T3,W140,L96,BLK,-	1	SA	
H213	AK61-00357A	SPRING ETC-CLAMPER;-,-,SUS304CSP,-,-,-,-,-	1	SA	
H214	AK66-00057A	GEAR-BACKLASH;DP-16,POM,0.5,-,-,WHT,-,RA	1	SA	
H241	AK41-00250B	FFC-PU;DP-16,HYPER,PET 0.037mm,23P,0.	1	SA	
W010	6003-001157	SCREW-TAPTITE;PWH,+ ,B,M2,L6,ZPC(YEL),SWR	1	SA	
W011	6001-001370	SCREW-MACHINE;CH,+ ,M1.7,L3.0,ZPC(YEL),SW	2	SA	
W012	6002-001086	SCREW-TAPPING;PH,+ ,B,M1.7,L5.0,ZPC(YEL),	3	SA	
W212	6003-001251	SCREW-TAPTITE;CH,+ ,B,M1.7,L3,ZPC(YEL),SW	1	SA	
W273	6003-000233	SCREW-TAPTITE;PH,+ ,B,M2,L6,ZPC(BLK),SWRC	1	SA	
W274	6001-001730	SCREW-MACHINE;BH,+ ,M1.7,L2.5,ZPC(YEL)	4	SA	

## 7. Electrical Parts List

Loc.No	Part No	Description ; Specification	Q'ty	S.N.A	Remark	Loc.No	Part No	Description ; Specification	Q'ty	S.N.A	Remark
P001	AK92-00680B	ASSY PCB-MAIN:DVD-P355/XEV,MAIN PCB ASSY	1	SA	CIS Only	AR100	2007-000113	R-CHIP:33ohm,5%,1/10W,TP,1608	1	SA	
	AK92-00680A	ASSY PCB-MAIN:DVD-P355/XEO,MAIN PCB ASSY	1	SA	Other Only	AR14	2007-000090	R-CHIP:10Kohm,5%,1/10W,TP,1608	1	SA	
AC100	2203-000426	C-CER,CHIP:0.018NF,5%,50V,COG,TP,1608	1	SA		AR15	2007-000075	R-CHIP:220ohm,5%,1/10W,TP,1608	1	SA	
AC19	2203-005148	C-CER,CHIP:100nF,10%,16V,X7R,TP,1608	1	SA		AR16	2007-000075	R-CHIP:220ohm,5%,1/10W,TP,1608	1	SA	
AC20	2203-005148	C-CER,CHIP:100nF,10%,16V,X7R,TP,1608	1	SA							
AC200	2203-005148	C-CER,CHIP:100nF,10%,16V,X7R,TP,1608	1	SA		AR17	2007-000078	R-CHIP:1Kohm,5%,1/10W,TP,1608	1	SA	
AC21	2203-000315	C-CER,CHIP:0.12NF,5%,50V,COG,TP,1608	1	SA		AR28	2007-000090	R-CHIP:10Kohm,5%,1/10W,TP,1608	1	SA	
AC22	2203-005148	C-CER,CHIP:100nF,10%,16V,X7R,TP,1608	1	SA		AR29	2007-000075	R-CHIP:220ohm,5%,1/10W,TP,1608	1	SA	
AC23	2203-000125	C-CER,CHIP:1.2nF,10%,50V,X7R,TP,1608,-	1	SA		AR30	2007-000075	R-CHIP:220ohm,5%,1/10W,TP,1608	1	SA	
AC25	2203-000315	C-CER,CHIP:0.12NF,5%,50V,COG,TP,1608	1	SA		AR31	2007-000078	R-CHIP:1Kohm,5%,1/10W,TP,1608	1	SA	
AC28	2203-001607	C-CER,CHIP:0.22nF,5%,50V,NP0,-,1608	1	SA		AR41	2007-000090	R-CHIP:10Kohm,5%,1/10W,TP,1608	1	SA	
AC29	2203-000125	C-CER,CHIP:1.2nF,10%,50V,X7R,TP,1608,-	1	SA		AR42	2007-000078	R-CHIP:1Kohm,5%,1/10W,TP,1608	1	SA	
AD1	0407-000114	DIODE-ARRAY:DAN202K,80V,100mA,CA2-3,SOT-	1	SA		AR43	2007-000092	R-CHIP:15Kohm,5%,1/10W,TP,1608	1	SA	
AD2	0407-000114	DIODE-ARRAY:DAN202K,80V,100mA,CA2-3,SOT-	1	SA		AR46	2007-000090	R-CHIP:10Kohm,5%,1/10W,TP,1608	1	SA	
AD3	0407-000114	DIODE-ARRAY:DAN202K,80V,100mA,CA2-3,SOT-	1	SA		AR47	2007-000078	R-CHIP:1Kohm,5%,1/10W,TP,1608	1	SA	
AD4	0401-000008	DIODE-SWITCHING:DAN217,80V,100MA,SOT-23,	1	SA		AR48	2007-000092	R-CHIP:15Kohm,5%,1/10W,TP,1608	1	SA	
AD5	0407-000114	DIODE-ARRAY:DAN202K,80V,100mA,CA2-3,SOT-	1	SA		AR52	2007-000078	R-CHIP:1Kohm,5%,1/10W,TP,1608	1	SA	
ADR1	2007-000080	R-CHIP:2Kohm,5%,1/10W,TP,1608	1	SA		AR54	2007-000102	R-CHIP:100Kohm,5%,1/10W,TP,1608	1	SA	
AE10	2401-002165	C-AL:100uF,20%,16V,GP,TP6,3x7,5	1	SA		AR55	2007-000077	R-CHIP:470ohm,5%,1/10W,TP,1608	1	SA	
AE11	2401-000913	C-AL:22uF,20%,16V,GP,TP5x11,5	1	SA		AR58	2007-000491	R-CHIP:2.2KOHM,1%,1/10W,TP,1608	1	SA	
AE13	2401-000913	C-AL:22uF,20%,16V,GP,TP5x11,5	1	SA		AR59	2007-000079	R-CHIP:1.8Kohm,5%,1/10W,TP,1608	1	SA	
AE15	2401-000438	C-AL:10uF,20%,25V,GP,-,5x11,5	1	SA		AR60	2007-000125	R-CHIP:3.9Kohm,5%,1/10W,TP,1608	1	SA	
AE16	2401-000302	C-AL:100uF,20%,25V,GP,TP6,3x11,5	1	SA		AR61	2007-000075	R-CHIP:220ohm,5%,1/10W,TP,1608	1	SA	
AE17	2401-000598	C-AL:1uF,20%,50V,GP,TP4x7,5	1	SA		AR62	2007-001134	R-CHIP:68ohm,5%,1/10W,TP,1608	1	SA	
AE3	2401-000913	C-AL:22uF,20%,16V,GP,TP5x11,5	1	SA		AR63	2007-000070	R-CHIP:0ohm,5%,1/10W,TP,1608	1	SA	
AE5	2401-000913	C-AL:22uF,20%,16V,GP,TP5x11,5	1	SA		AR64	2007-000102	R-CHIP:100Kohm,5%,1/10W,TP,1608	1	SA	
AE6	2401-000913	C-AL:22uF,20%,16V,GP,TP5x11,5	1	SA		AR65	2007-000070	R-CHIP:0ohm,5%,1/10W,TP,1608	1	SA	
AE9	2401-002594	C-AL:220uF,20%,16V,GP,TP8x11.5,5	1	SA		AR71	2007-000078	R-CHIP:1Kohm,5%,1/10W,TP,1608	1	SA	
AHC1	2203-005148	C-CER,CHIP:100nF,10%,16V,X7R,TP,1608	1	SA		AR72	2007-000078	R-CHIP:1Kohm,5%,1/10W,TP,1608	1	SA	
AHC2	2203-005148	C-CER,CHIP:100nF,10%,16V,X7R,TP,1608	1	SA		AR73	2007-000078	R-CHIP:1Kohm,5%,1/10W,TP,1608	1	SA	
AHE10	2401-001250	C-AL:4.7uF,20%,35V,GP,TP4x5,5	1	SA		AR74	2007-000124	R-CHIP:2.2Kohm,5%,1/10W,TP,1608	1	SA	
AHE20	2401-001250	C-AL:4.7uF,20%,35V,GP,TP4x5,5	1	SA		DCN1	3708-000491	CONNECTOR-FPC/FPC/PIC:23P,1mm,STRAIGHT,S	1	SA	
AHC1C	1201-000163	IC-OP AMP:4560,SOP8P,173MIL,DUAL,100V/m	1	SA		DCN2	3708-001266	CONNECTOR-FPC/FPC/PIC:11P,1MM,STRAIGHT,S	1	SA	
AHR1	2007-000102	R-CHIP:100Kohm,5%,1/10W,TP,1608	1	SA		DOC4	2203-005148	C-CER,CHIP:100nF,10%,16V,X7R,TP,1608	1	SA	
AHR2	2007-000102	R-CHIP:100Kohm,5%,1/10W,TP,1608	1	SA		DOE1	2401-000598	C-AL:1uF,20%,50V,GP,TP4x7,5	1	SA	
AHR5	2007-000075	R-CHIP:220ohm,5%,1/10W,TP,1608	1	SA		DOIC2	3707-001065	CONNECTOR-OPTICAL:PLUG,GP1FA550TZ,6dB,2.	1	SA	
AHR6	2007-000075	R-CHIP:220ohm,5%,1/10W,TP,1608	1	SA		DOL1	2901-001273	FILTER-EMI SMD:50V,2A-,220pF,3.2x1.6x0.	1	SA	
AIC1	1002-001395	IC-D/A CONVERTER:PCM11753,24Bit,SSOP,16P,	1	SA		DOL2	3301-001419	BEAD-SMD,-,220-,500,TP,-,0.3	1	SA	
AIC4	1201-000163	IC-OP AMP:4560,SOP8P,173MIL,DUAL,100V/m	1	SA		DOR3	2007-000075	R-CHIP:220ohm,5%,1/10W,TP,1608	1	SA	
AL2	3301-001419	BEAD-SMD,-,220-,500,TP,-,0.3	1	SA		DQ1	0501-000341	TR-SMALL SIGNAL:KSC1623-L,NPN,200mW,SOT-	1	SA	
AQ1	0504-000128	TR-DIGITAL:-,NPN,200MW,22K/22K,SOT-23,TP	1	SA		DQ2	0501-000341	TR-SMALL SIGNAL:KSC1623-L,NPN,200mW,SOT-	1	SA	
AQ10	0501-000341	TR-SMALL SIGNAL:KSC1623-L,NPN,200mW,SOT-	1	SA		DQ3	0501-000341	TR-SMALL SIGNAL:KSC1623-L,NPN,200mW,SOT-	1	SA	
AQ11	0501-000341	TR-SMALL SIGNAL:KSC1623-L,NPN,200mW,SOT-	1	SA		DR1	2007-000090	R-CHIP:10Kohm,5%,1/10W,TP,1608	1	SA	
AQ2	0504-000156	TR-DIGITAL:KSR2103,PNP,200MW,22K/22K,SOT	1	SA		DR2	2007-000090	R-CHIP:10Kohm,5%,1/10W,TP,1608	1	SA	
AQ3	0501-000341	TR-SMALL SIGNAL:KSC1623-L,NPN,200mW,SOT-	1	SA		DR3	2007-000463	R-CHIP:18ohm,5%,1/10W,TP,1608	1	SA	
AQ4	0504-000128	TR-DIGITAL:-,NPN,200MW,22K/22K,SOT-23,TP	1	SA		DR4	2007-000122	R-CHIP:1.2Kohm,5%,1/10W,TP,1608	1	SA	
AQ5	0504-000156	TR-DIGITAL:KSR2103,PNP,200MW,22K/22K,SOT	1	SA		DR5	2007-000090	R-CHIP:10Kohm,5%,1/10W,TP,1608	1	SA	
AQ6	0501-000341	TR-SMALL SIGNAL:KSC1623-L,NPN,200mW,SOT-	1	SA		DR6	2007-001134	R-CHIP:68ohm,5%,1/10W,TP,1608	1	SA	
AQ7	0504-000128	TR-DIGITAL:-,NPN,200MW,22K/22K,SOT-23,TP	1	SA		FC1	2203-000257	C-CER,CHIP:10nF,10%,50V,X7R,TP,1608	1	SA	
AQ8	0504-000156	TR-DIGITAL:KSR2103,PNP,200MW,22K/22K,SOT	1	SA		FC10	2203-005148	C-CER,CHIP:100nF,10%,16V,X7R,TP,1608	1	SA	
AQ9	0501-000002	TR-SMALL SIGNAL:KSA812,PNP,150MW,SOT-23,	1	SA		FC11	2203-001222	C-CER,CHIP:0.82NF,10%,50V,X7R,TP,1608	1	SA	
						FC12	2203-005148	C-CER,CHIP:100nF,10%,16V,X7R,TP,1608	1	SA	

Electrical Parts List

Loc.No	Part No	Description ; Specification	Q'ty	S.N.A	Remark	Loc.No	Part No	Description ; Specification	Q'ty	S.N.A	Remark
FC2	2203-001607	C-CER,CHIP:0.22nF,5%,50V,NPO,-,1608	1	SA		KQ11	0501-000279	TR-SMALL SIGNAL:KSA1182-Y,PNP,150mW,SOT-	1	SA	
FC3	2203-000257	C-CER,CHIP:10nF,10%,50V,X7R,TP,1608	1	SA		KQ12	0501-000279	TR-SMALL SIGNAL:KSA1182-Y,PNP,150mW,SOT-	1	SA	
FC4	2203-000669	C-CER,CHIP:27nF,10%,25V,X7R,TP,1608,-	1	SA		KQ13	0501-000279	TR-SMALL SIGNAL:KSA1182-Y,PNP,150mW,SOT-	1	SA	
FC5	2203-000140	C-CER,CHIP:1.5nF,10%,50V,X7R,1608	1	SA		KQ14	0501-000279	TR-SMALL SIGNAL:KSA1182-Y,PNP,150mW,SOT-	1	SA	
FC6	2203-000669	C-CER,CHIP:27nF,10%,25V,X7R,TP,1608,-	1	SA		KQ15	0501-000279	TR-SMALL SIGNAL:KSA1182-Y,PNP,150mW,SOT-	1	SA	
FC8	2203-005148	C-CER,CHIP:100nF,10%,16V,X7R,TP,1608	1	SA		KQ16	0501-000279	TR-SMALL SIGNAL:KSA1182-Y,PNP,150mW,SOT-	1	SA	
FC9	2203-000257	C-CER,CHIP:10nF,10%,50V,X7R,TP,1608	1	SA		KQ17	0501-000341	TR-SMALL SIGNAL:KSC1623-L,NPN,200mW,SOT-	1	SA	
FE1	2401-002144	C-AL:47uF,20%,16V,GP,TP,5x11,5	1	SA		KQ2	0501-000341	TR-SMALL SIGNAL:KSC1623-L,NPN,200mW,SOT-	1	SA	
FE2	2401-002144	C-AL:47uF,20%,16V,GP,TP,5x11,5	1	SA		KQ3	0501-000341	TR-SMALL SIGNAL:KSC1623-L,NPN,200mW,SOT-	1	SA	
FE3	2401-002144	C-AL:47uF,20%,16V,GP,TP,5x11,5	1	SA		KQ4	0501-000341	TR-SMALL SIGNAL:KSC1623-L,NPN,200mW,SOT-	1	SA	
FIC1	1003-001735	IC-MOTOR DRIVER:FAN8026G3,SSOPH,28P,18.4	1	SA		KQ5	0501-000341	TR-SMALL SIGNAL:KSC1623-L,NPN,200mW,SOT-	1	SA	
FR1	2007-000130	R-CHIP:39Kohm,5%,1/10W,TP,1608	1	SA		KQ6	0501-000341	TR-SMALL SIGNAL:KSC1623-L,NPN,200mW,SOT-	1	SA	
FR10	2007-000092	R-CHIP:15Kohm,5%,1/10W,TP,1608	1	SA		KQ7	0501-000341	TR-SMALL SIGNAL:KSC1623-L,NPN,200mW,SOT-	1	SA	
FR11	2007-000129	R-CHIP:27Kohm,5%,1/10W,TP,1608	1	SA		KQ8	0501-000341	TR-SMALL SIGNAL:KSC1623-L,NPN,200mW,SOT-	1	SA	
FR12	2007-000329	R-CHIP:11Kohm,5%,1/10W,TP,1608	1	SA		KQ9	0501-000341	TR-SMALL SIGNAL:KSC1623-L,NPN,200mW,SOT-	1	SA	
FR13	2007-000094	R-CHIP:22Kohm,5%,1/10W,TP,1608	1	SA		KR1	2007-000074	R-CHIP:100ohm,5%,1/10W,TP,1608	1	SA	
FR14	2007-000078	R-CHIP:1Kohm,5%,1/10W,TP,1608	1	SA		KR10	2007-000072	R-CHIP:47ohm,5%,1/10W,TP,1608	1	SA	
FR15	2007-000129	R-CHIP:27Kohm,5%,1/10W,TP,1608	1	SA		KR100	2001-000527	R-CARBON:220HM,5%,1/8W,AA,TP,1.8X3.2MM	1	SA	
FR16	2007-007277	R-CHIP:392ohm,1%,1/10W,TP,1608	1	SA		KR11	2007-000124	R-CHIP:2.2Kohm,5%,1/10W,TP,1608	1	SA	
FR19	2007-000090	R-CHIP:10Kohm,5%,1/10W,TP,1608	1	SA		KR12	2007-000078	R-CHIP:1Kohm,5%,1/10W,TP,1608	1	SA	
FR2	2007-000090	R-CHIP:10Kohm,5%,1/10W,TP,1608	1	SA		KR13	2007-000078	R-CHIP:1Kohm,5%,1/10W,TP,1608	1	SA	
FR23	2007-000086	R-CHIP:5.6Kohm,5%,1/10W,TP,1608	1	SA		KR14	2007-000078	R-CHIP:1Kohm,5%,1/10W,TP,1608	1	SA	
FR24	2007-000086	R-CHIP:5.6Kohm,5%,1/10W,TP,1608	1	SA		KR15	2007-000078	R-CHIP:1Kohm,5%,1/10W,TP,1608	1	SA	
FR25	2007-000086	R-CHIP:5.6Kohm,5%,1/10W,TP,1608	1	SA		KR16	2007-000078	R-CHIP:1Kohm,5%,1/10W,TP,1608	1	SA	
FR26	2007-000094	R-CHIP:22Kohm,5%,1/10W,TP,1608	1	SA		KR17	2007-000078	R-CHIP:1Kohm,5%,1/10W,TP,1608	1	SA	
FR28	2007-007277	R-CHIP:392ohm,1%,1/10W,TP,1608	1	SA		KR18	2007-000078	R-CHIP:1Kohm,5%,1/10W,TP,1608	1	SA	
FR3	2007-000098	R-CHIP:56Kohm,5%,1/10W,TP,1608	1	SA		KR19	2007-000078	R-CHIP:1Kohm,5%,1/10W,TP,1608	1	SA	
FR31	2007-000134	R-CHIP:33Kohm,5%,1/10W,TP,1608	1	SA		KR2	2007-000090	R-CHIP:10Kohm,5%,1/10W,TP,1608	1	SA	
FR33	2007-000091	R-CHIP:12Kohm,5%,1/10W,TP,1608	1	SA		KR20	2007-000078	R-CHIP:1Kohm,5%,1/10W,TP,1608	1	SA	
FR34	2007-000134	R-CHIP:33Kohm,5%,1/10W,TP,1608	1	SA		KR21	2007-000078	R-CHIP:1Kohm,5%,1/10W,TP,1608	1	SA	
FR36	2007-000091	R-CHIP:12Kohm,5%,1/10W,TP,1608	1	SA		KR22	2007-000078	R-CHIP:1Kohm,5%,1/10W,TP,1608	1	SA	
FR37	2007-000084	R-CHIP:4.7Kohm,5%,1/10W,TP,1608	1	SA		KR23	2007-000078	R-CHIP:1Kohm,5%,1/10W,TP,1608	1	SA	
FR39	2007-000084	R-CHIP:4.7Kohm,5%,1/10W,TP,1608	1	SA		KR24	2007-000078	R-CHIP:1Kohm,5%,1/10W,TP,1608	1	SA	
FR4	2007-000129	R-CHIP:27Kohm,5%,1/10W,TP,1608	1	SA		KR25	2007-000078	R-CHIP:1Kohm,5%,1/10W,TP,1608	1	SA	
FR41	2007-000090	R-CHIP:10Kohm,5%,1/10W,TP,1608	1	SA		KR26	2007-000078	R-CHIP:1Kohm,5%,1/10W,TP,1608	1	SA	
FR42	2007-000491	R-CHIP:2.2KOHM,1%,1/10W,TP,1608	1	SA		KR27	2007-000071	R-CHIP:22ohm,5%,1/10W,TP,1608	1	SA	
FR43	2007-000491	R-CHIP:2.2KOHM,1%,1/10W,TP,1608	1	SA		KR28	2007-000071	R-CHIP:22ohm,5%,1/10W,TP,1608	1	SA	
FR44	2007-000091	R-CHIP:12Kohm,5%,1/10W,TP,1608	1	SA		KR29	2007-000071	R-CHIP:22ohm,5%,1/10W,TP,1608	1	SA	
FR5	2007-000086	R-CHIP:5.6Kohm,5%,1/10W,TP,1608	1	SA		KR3	2007-000074	R-CHIP:100ohm,5%,1/10W,TP,1608	1	SA	
FR7	2007-000086	R-CHIP:5.6Kohm,5%,1/10W,TP,1608	1	SA		KR30	2007-000071	R-CHIP:22ohm,5%,1/10W,TP,1608	1	SA	
FR8	2007-000086	R-CHIP:5.6Kohm,5%,1/10W,TP,1608	1	SA		KR31	2007-000071	R-CHIP:22ohm,5%,1/10W,TP,1608	1	SA	
FR9	2007-000090	R-CHIP:10Kohm,5%,1/10W,TP,1608	1	SA		KR32	2007-000071	R-CHIP:22ohm,5%,1/10W,TP,1608	1	SA	
KC1	2203-005148	C-CER,CHIP:100nF,10%,16V,X7R,TP,1608	1	SA		KR33	2007-000071	R-CHIP:22ohm,5%,1/10W,TP,1608	1	SA	
KC2	2203-005065	C-CER,CHIP:100nF,+80-20%,10V,Y5V,1608	1	SA		KR34	2007-000084	R-CHIP:4.7Kohm,5%,1/10W,TP,1608	1	SA	
KC3	2203-000140	C-CER,CHIP:1.5nF,10%,50V,X7R,1608	1	SA		KR35	2007-000084	R-CHIP:4.7Kohm,5%,1/10W,TP,1608	1	SA	
KC4	2203-000440	C-CER,CHIP:1nF,10%,50V,X7R,TP,1608,-	1	SA		KR36	2007-000124	R-CHIP:2.2Kohm,5%,1/10W,TP,1608	1	SA	
KE1	2401-002144	C-AL:47uF,20%,16V,GP,TP,5x11,5	1	SA		KR37	2007-000071	R-CHIP:22ohm,5%,1/10W,TP,1608	1	SA	
KE2	2401-000414	C-AL:10uF,20%,16V,GP,TP,4x7,5	1	SA		KR4	2007-000090	R-CHIP:10Kohm,5%,1/10W,TP,1608	1	SA	
KE3	2401-002165	C-AL:100uF,20%,16V,GP,TP,6.3x7,5	1	SA		KR5	2007-000083	R-CHIP:3Kohm,5%,1/10W,TP,1608	1	SA	
KIC1	AK09-00075B	IC MICOM:eFHP5842,SPINO,24PIN,-0.3V - 6	1	SA		KR6	2007-000123	R-CHIP:1.5Kohm,5%,1/10W,TP,1608	1	SA	
KIC2	1203-003526	IC-VOL. DETECTOR:KA75290,TO-92,3P,4.58x4	1	SA		KR7	2007-000084	R-CHIP:4.7Kohm,5%,1/10W,TP,1608	1	SA	
KIR1	0609-001188	MODULE REMOCOM-VERTICAL,9.6MM,TR	1	SA		KR8	2007-000090	R-CHIP:10Kohm,5%,1/10W,TP,1608	1	SA	
KML1	AK07-00030A	LED DISPLAY:BCD-9030B,DVD-P250K,-,7,7,27	1	SA		KR9	2007-000090	R-CHIP:10Kohm,5%,1/10W,TP,1608	1	SA	
KQ1	0501-000341	TR-SMALL SIGNAL:KSC1623-L,NPN,200mW,SOT-	1	SA		KSW1	3404-001261	SWITCH-TACT:15V DC,20mA,100gf,7.4X7.95X1	1	SA	
KQ10	0501-000279	TR-SMALL SIGNAL:KSA1182-Y,PNP,150mW,SOT-	1	SA		KSW2	3404-001261	SWITCH-TACT:15V DC,20mA,100gf,7.4X7.95X1	1	SA	









Electrical Parts List

Loc.No	Part No	Description ; Specification	Q'ty	S.N.A	Remark	Loc.No	Part No	Description ; Specification	Q'ty	S.N.A	Remark
ZR8	3301-001309	BEAD-SMD:470HM,1608,500,TP,-,0.3	1	SA		I/B	AK68-00632G	MANUAL USERS:DVD-P355,XEL,GER/FRA/NL/ENG	1	SA	
ZR9	2007-001164	R-CHIP:75ohm,1%,1/10W,TP,1608	1	SA		P-CASE	AK69-00355E	PACKING CASE:DVD-P355B/XEL,SW-2,FLEXO,T5	1	SA	
ZY1	2801-003554	CRYSTAL-UNIT:27MHz,10ppm,28-AAM,12pF,40o	1	SA							
<b>H100</b>	<b>AK97-01011A</b>	<b>ASSY-DVD DECK:DP-17V,LEFT,BLACK</b>	<b>1</b>	<b>SNA</b>							
H401	AK61-00358A	FRAME-MAIN:DP-17,ABS,SR-0320,94HB,BLK,T3	1	SNA							
DSW1	3403-001026	SWITCH-PUSH:5V,0.7mA,DPST,OFF-ON-OFF,-	1	SA							
S.N.A	AH97-00448B	ASSY-SUB MATERIAL:DP-7S,-,-	1	SNA							
S.N.A	AK97-01005A	ASSY-HOUSING:DP-17,LEFT,BLACK	1	SNA							
S.N.A	AK97-01006A	ASSY-HOLDER CHUCK,-,DP-16,-	1	SNA							
S.N.A	AK97-01105A	ASSY-P U DECK,-,DP-16S,-	1	SNA							
S.N.A	0205-001033	GREASE-PL-30G,W050030019,-	0.5	SNA							
S.N.A	0205-001048	GREASE-BEARING:G-754,BRN,1Kg/6	0.01	SNA							
S.N.A	AK97-01106A	ASSY-SUB DECK,-,DP-16S,SEM	1	SNA							
S.N.A	AK41-00249A	FFC-DECK:DP-17,-,11P,-,1mm	1	SNA							
S.N.A	AK41-00251A	PCB-DECK:DP-17,PHENOL,1,-,T1.6,-,-,-,-	1	SNA							
S.N.A	AH31-00025A	MOTOR-LOADING:RF-300EA-1D390,DP-7,170mA,	1	SNA							
S.N.A	AK66-00058A	PULLEY-MOTOR:DP-17,POM,-,BLK,I3.5,O7.0,H	1	SNA							
S.N.A	AK61-00362A	BRACKET-DECK OUTSERT:DP-16,POM,T1.2,-,-,-	1	SNA							
S.N.A	AH66-00077A	GEAR-FEED MOTOR,-,POM M90-44,-,-,-,-,-	1	SNA							
S.N.A	AK31-00006A	MOTOR-FEED:RF-300EA-1D390,DP-9,90MA,-,-,-	1	SNA							
S.N.A	AK61-00361A	BRACKET-DECK:DP-16,SECC T1.2,T1.2,-,-,GR	1	SNA							
W010	6003-001157	SCREW-TAPTITE:PW,H,+ ,B,M2,L6,ZPC(YEL),SWR	1	SA							
W012	6002-001086	SCREW-TAPPING:PH,+ ,B,M1.7,L5.0,ZPC(YEL),	2	SA							
<b>A001</b>	<b>AK59-00011K</b>	<b>REMOCON-ASSY:DVD-P240/XAA,XAA,-,-,-,36,-,-</b>	<b>1</b>	<b>SA</b>							
VS001	AK61-00138K	CASE-TOP:DVD-P240/XAA,ABS 94 HB,-,-,-,G	1	SNA							
VS052	AK61-00139A	CASE-BOTTOM:VR-6036,ABS 94 HB,-,-,-,GRY,	1	SNA							
C643	AK64-00330A	DOOR-BATTERY:VR-6036,ABS 94 HB,-,-,-,GRY,	1	SNA							
S.N.A	AK64-00332F	BUTTON-RUBBER:DVD-P241/XAA,SILICONE,-,-,-	1	SNA							
S.N.A	AK97-00472A	ASSY COMMON-REMOCON:VR-6036,-,-,-	1	SNA							
	AD99-40085Q	ASSY COMMON-REMOCON,c:VR-6036,-,-,-	1	SNA							
CT2	2203-000236	C-CER,CHIP:0.1NF,5%,50V,COG,TP,1608	1	SA							
CT3	2203-000236	C-CER,CHIP:0.1NF,5%,50V,COG,TP,1608	1	SA							
CT4	2203-005148	C-CER,CHIP:100nF,10%,16V,X7R,TP,1608	1	SA							
IC01	AH09-00039C	IC MICOM:S3C1860-XXXX,-,20P,1.8-3.6V,-,-	1	SNA							
PCB	AK41-00133A	PCB:P4101-000097A,PHENOL,1,01,1.6,	1	SNA							
RT1	2007-00007D	R-CHIP:0ohm,5%,1/10W,TP,1608	1	SA							
	AD99-50056J	ASSY COMMON-REMOCON,t:VR-6036,-,-,-	1	SNA							
CT1	2401-002206	C-AL:47uf,20%,6.3V,GP,TP,5x7.5mm	1	SA							
	AD99-90091P	ASSY COMMON-REMOCON,m:VR-6036,-,-,-	1	SNA							
LDT1	0601-000519	LED-IR:ROUND,5mm,170mW,4V,940nm,-	1	SA							
S.N.A	6902-000422	BAG PE-LDPE,TO.08,W80,L300,TRP,-,-,PE	1	SNA							
S.N.A	AC68-51211A	LABEL-PASSED:REMOCON,ARP PAPER,-,-,-,-,-	1	SNA							
S.N.A	AK61-00154A	SPRING ETC-REMOCON A(+):VR-6036,CS NI-CO	1	SNA							
S.N.A	AK61-00155A	SPRING ETC-REMOCON B(-):VR-6036,CS NI-CO	1	SNA							
S.N.A	AK61-00156A	SPRING ETC-REMOCON C:VR-6036,CS NI-CO S	1	SNA							
C457	AK64-00331A	WINDOW-REMOCON:VR-6036,PC,-,-,-,-,VIO,-	1	SNA							
XT01	2802-000148	RESONATOR-CERAMIC:455KHz,0.4%,BK,7.0x3.5	1	SNA							
S.N.A	AC39-42001R	CABLE-A/V:PVC,-,-,-,3P,-,-,-	1	SA							
W001	6003-000275	SCREW-TAPTITE:BH,+ ,B,M3,L10,BLK ,SWCH101	4	SA							
W275	6003-001561	SCREW-TAPTITE:BH,+ ,WTB,M3,L6,ZPC(YEL),S	7	SA							

## 8. Block Diagram

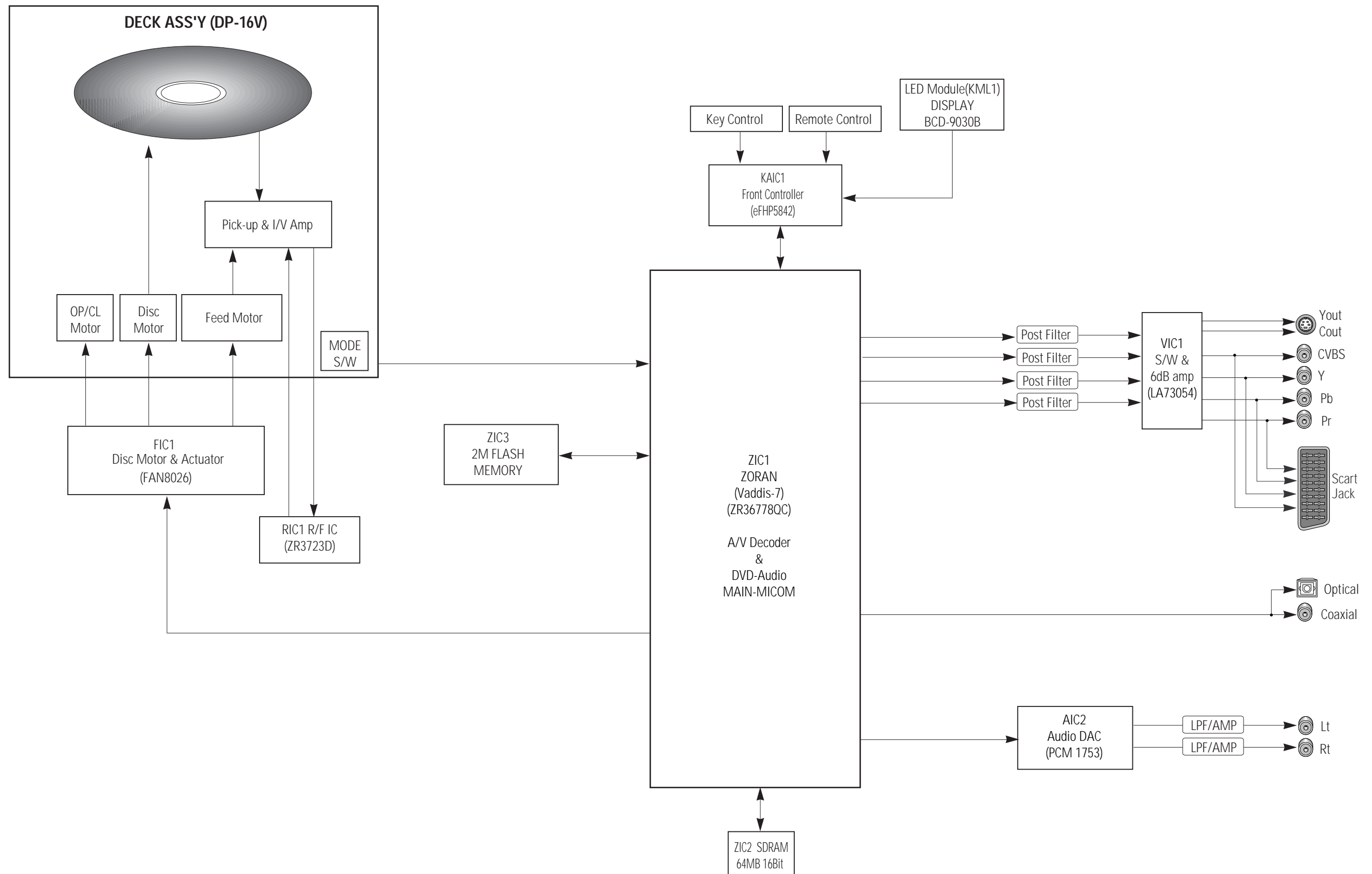

## 9. Wiring Diagram

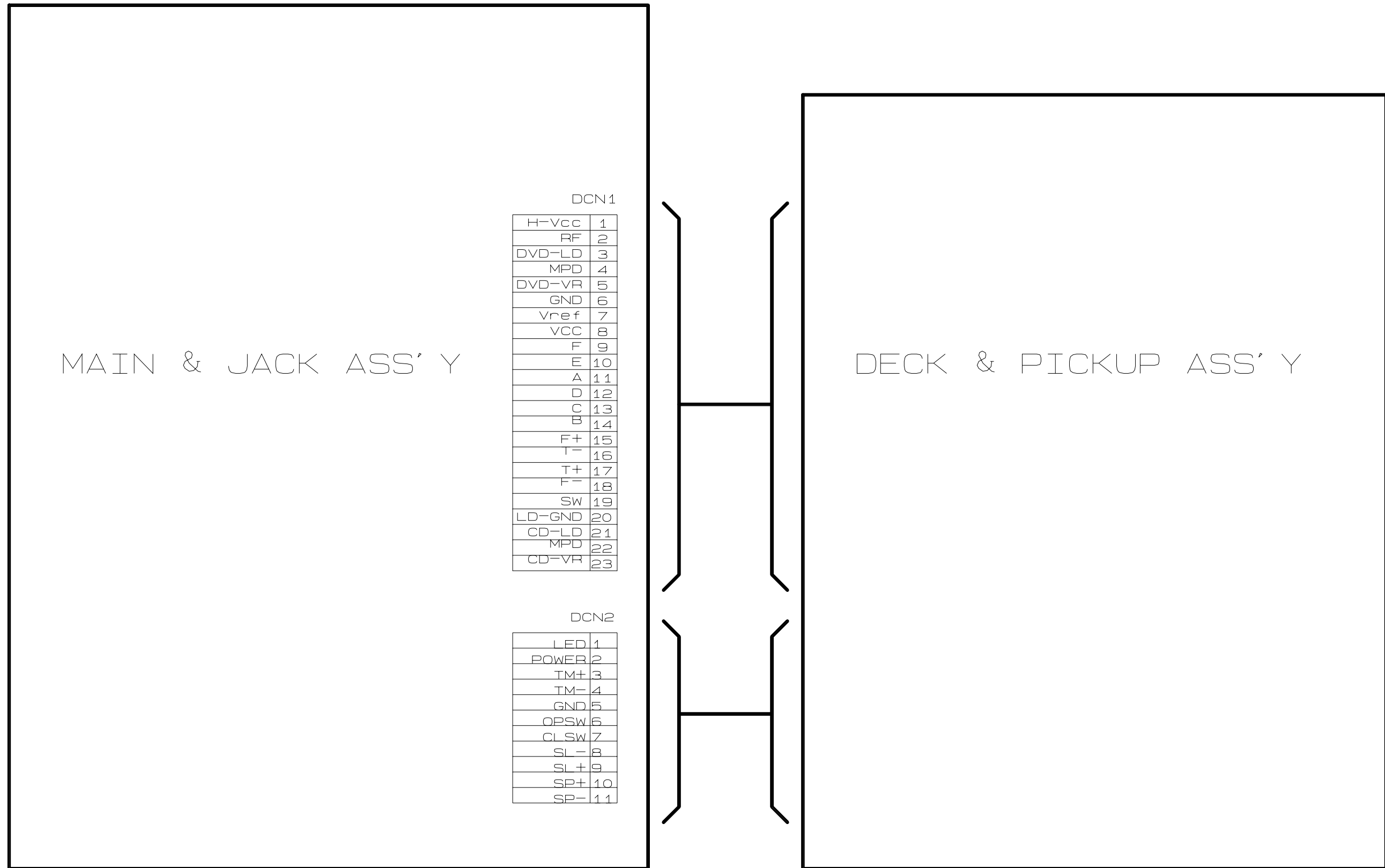

## 11. Schematic Diagrams

11-1 Power Drive	-----	11-2
11-2 Servo	-----	11-3
11-3 AV-Decoder	-----	11-4
11-4 Front Micom	-----	11-5
11-5 Audio	-----	11-6
11-6 Video	-----	11-7

### Note

For schematic Diagram  
- Resistors are in ohms, 1/8W unless otherwise noted.

#### Special note :

Most semiconductor devices are electrostatically sensitive and therefore require the special handling techniques described under the "electrostatically sensitive (ES) devices" section of this service manual.

#### Note :

Do not use the part number shown on this drawing for ordering. The correct part number is shown in the parts list (may be slightly different or amended since this drawing was prepared).

#### Important safety notices :

Components identified with the mark  have the special characteristics for safety. When replacing any of these components. Use only the same type.

### Block Identification of PCB

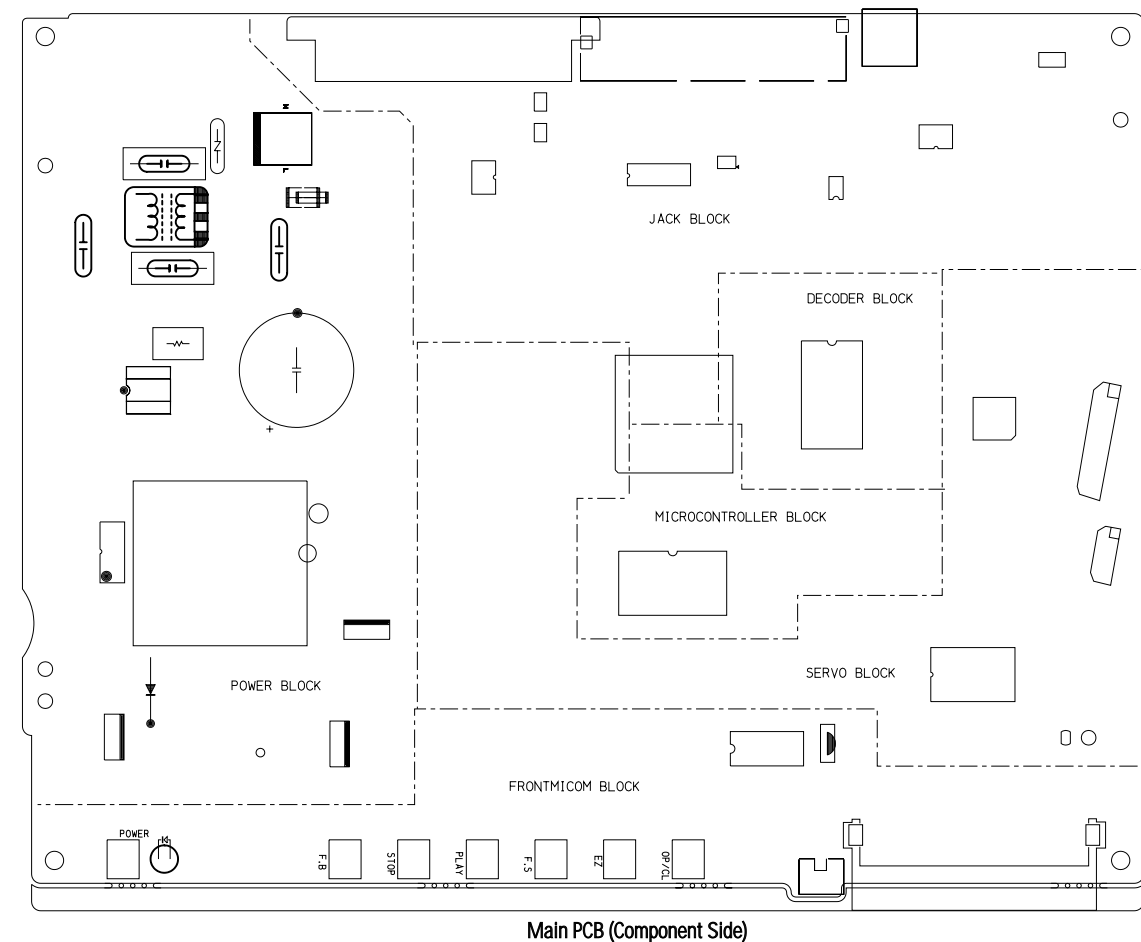

### 11-1 Power Drive

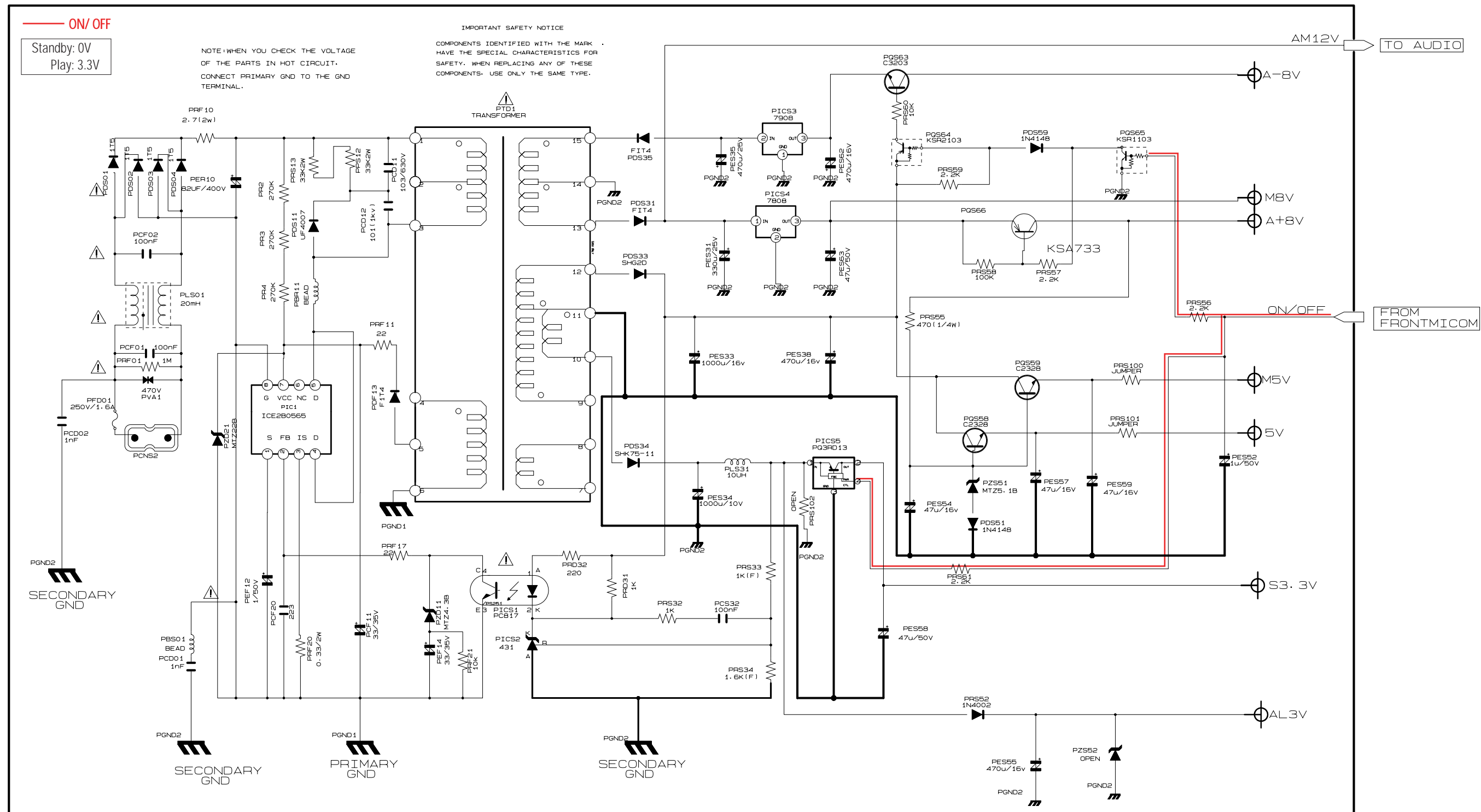

11-2 Servo

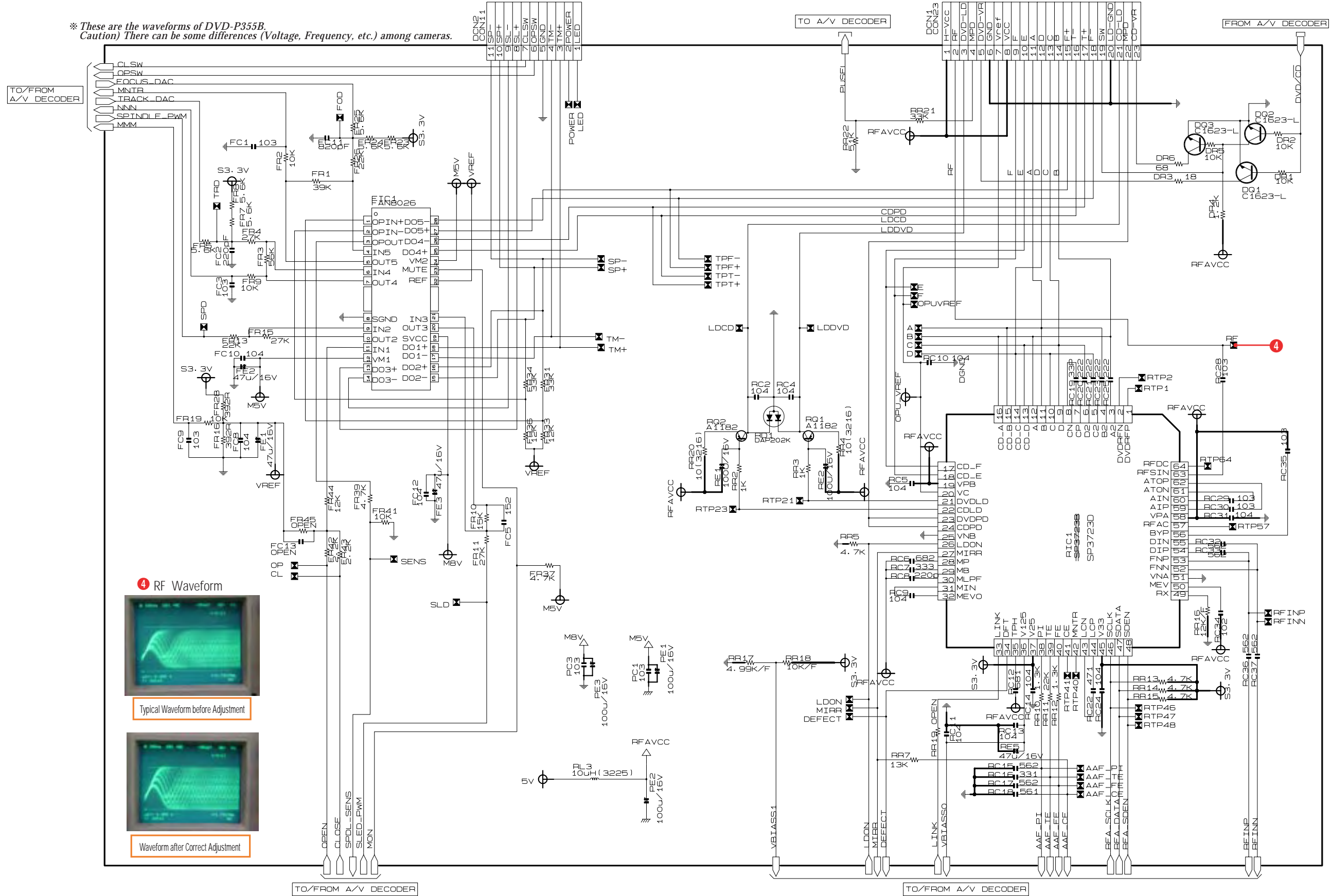

### 11-3 AV-Decoder

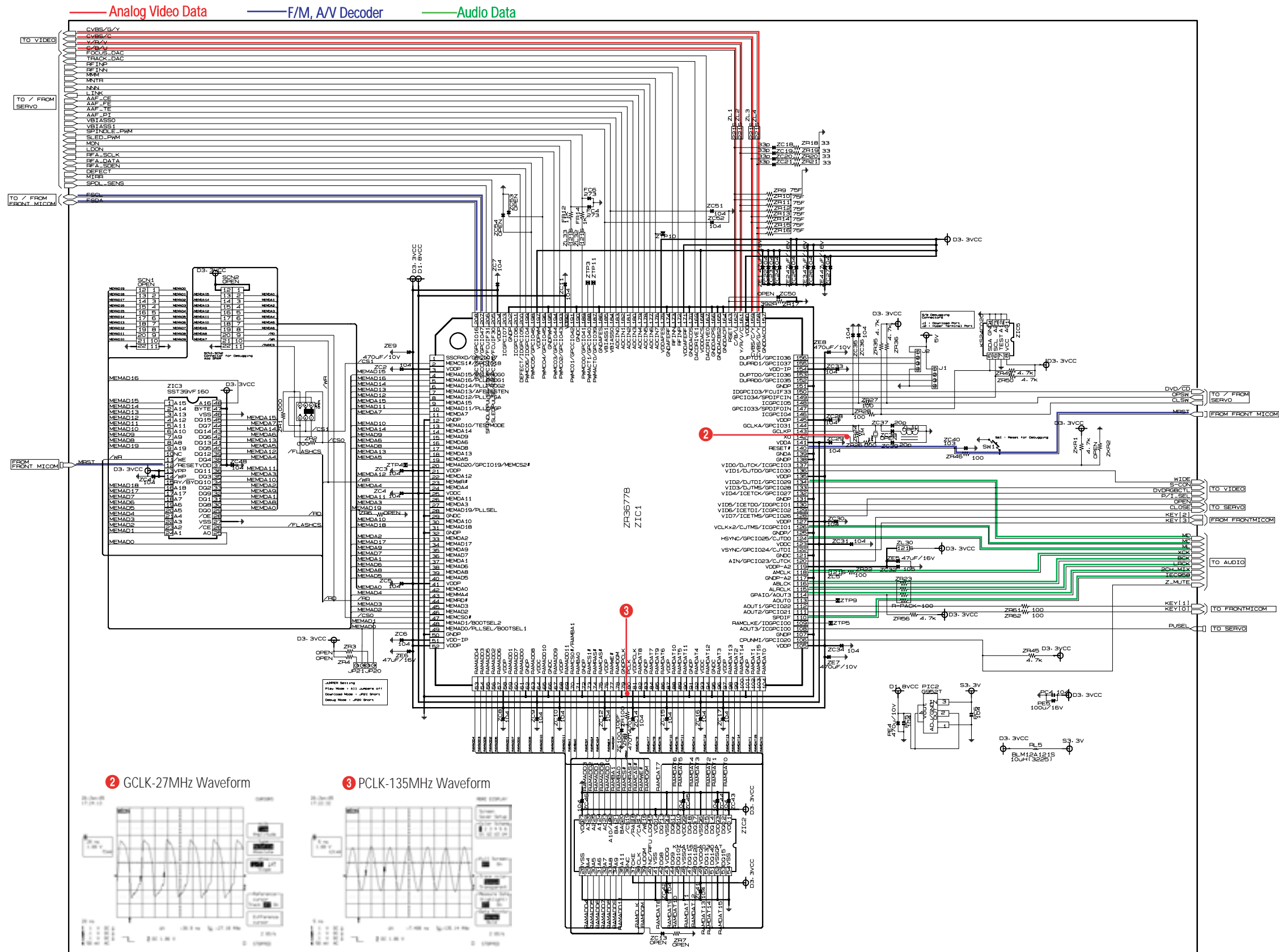

\* These are the waveforms of DVD-P355B.  
 Caution) There can be some differences (Voltage, Frequency, etc.) among cameras.



11-4 Fromt Micom

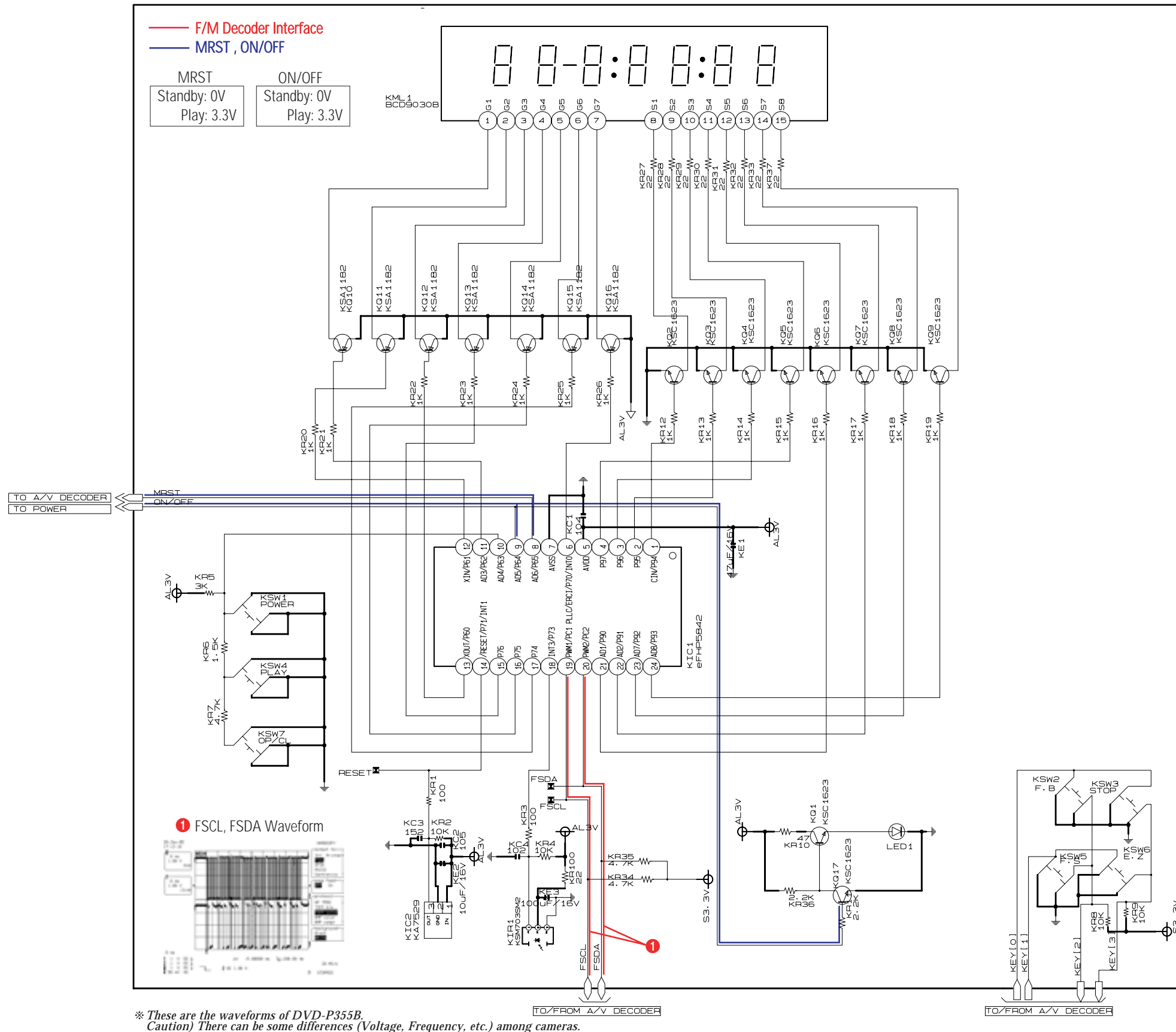

### 11-5 Audio

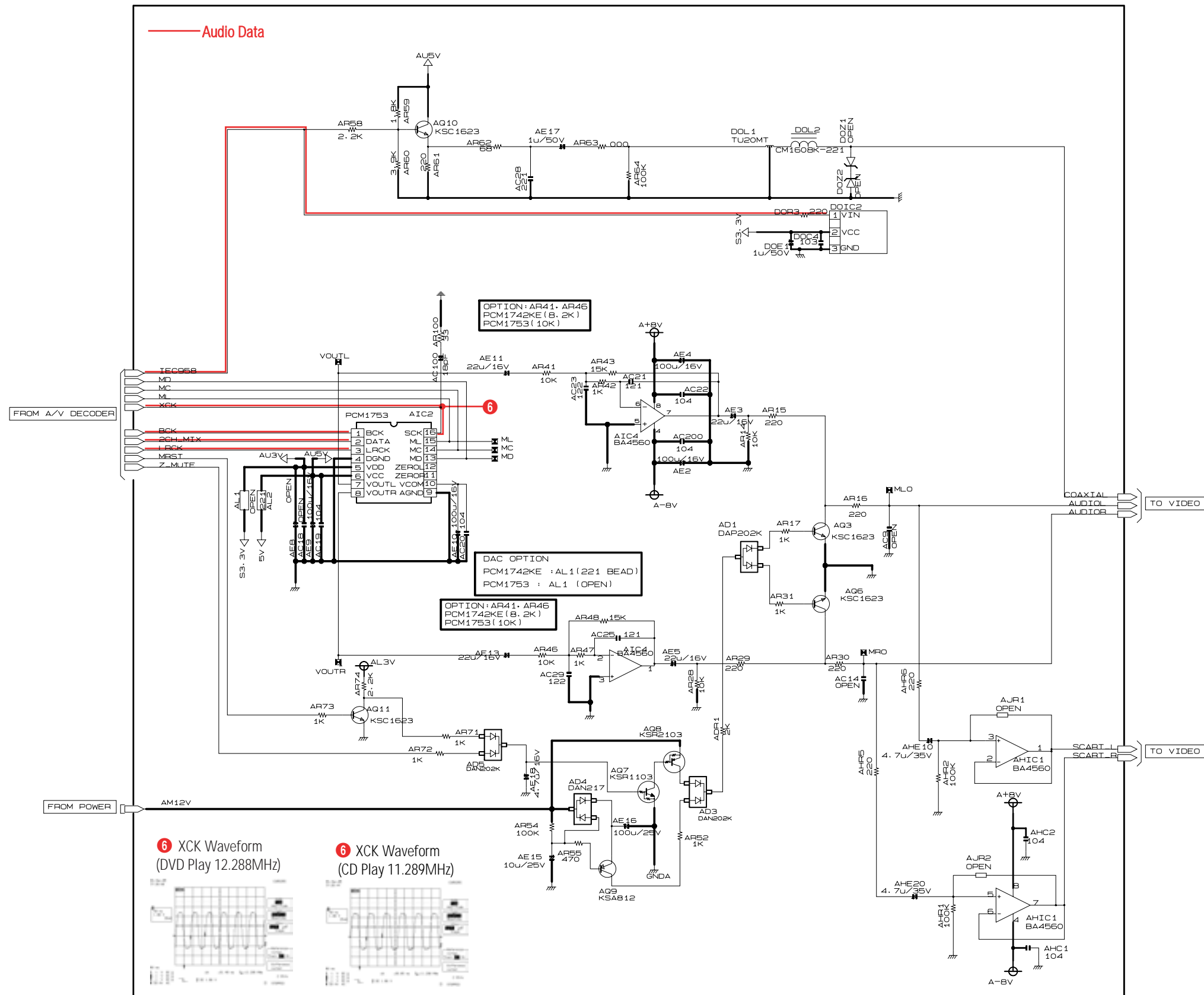

\* These are the waveforms of DVD-P355B.  
Caution) There can be some differences (Voltage, Frequency, etc.) among cameras.

11-6 Video

\* These are the waveforms of DVD-P355B.  
Caution) There can be some differences (Voltage, Frequency, etc.) among cameras.

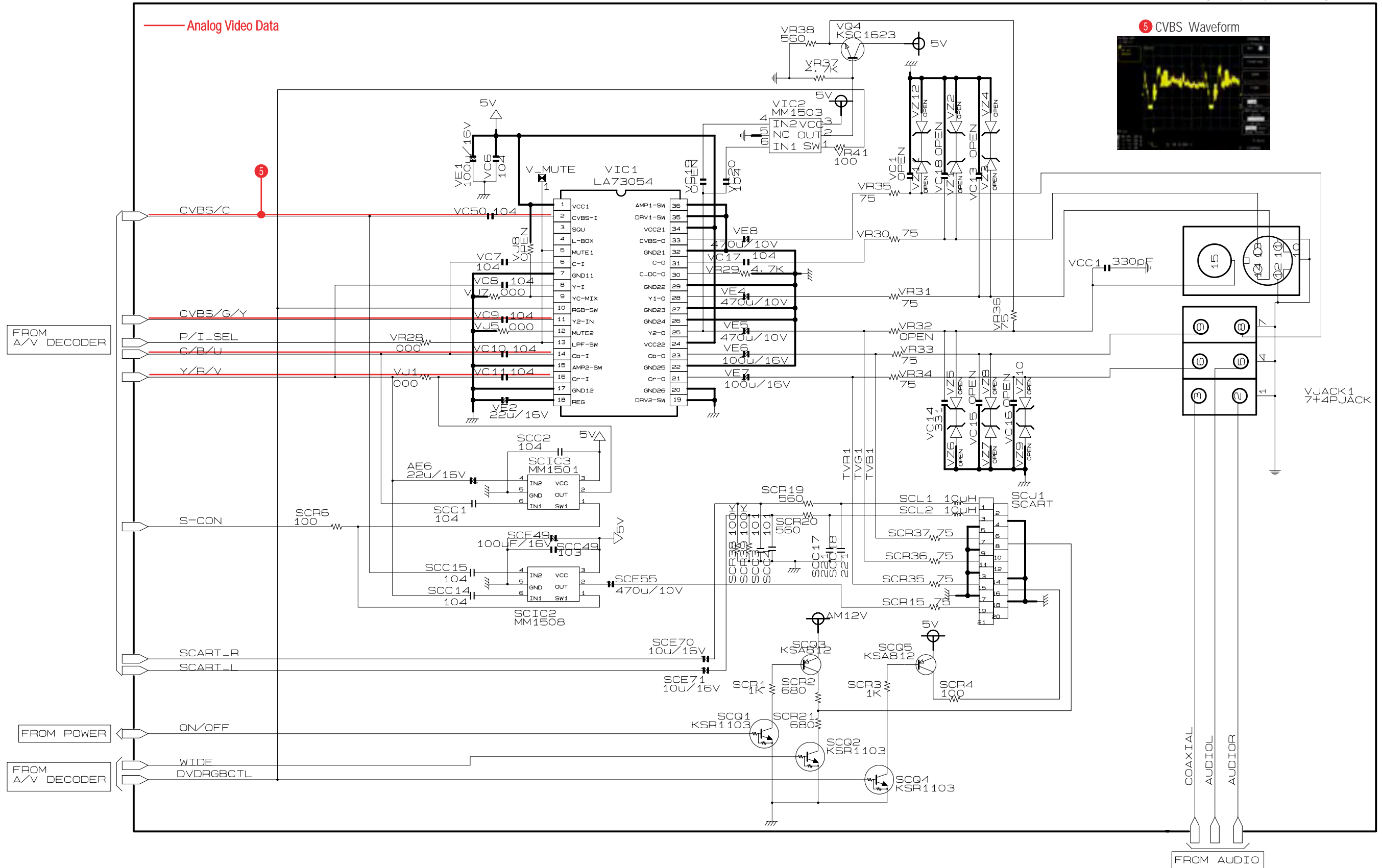

## MEMO

## 12. Operating Instructions

### SETUP

## Description

### Front Panel Controls

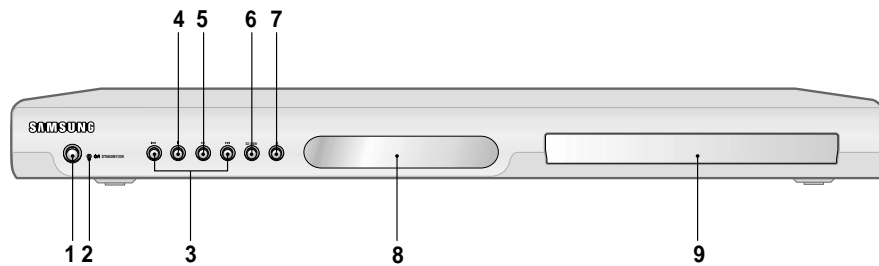

- 1. STANDBY/ON (⏻)**  
When STANDBY/ON is pressed on, the indicator goes out and the player is turned on.
- 2. STANDBY indicator**  
When the unit is first plugged in, this indicator lights.
- 3. SKIP (⏮/⏭) SEARCH**  
Allow you to search forward/backward through a disc. Use to skip the title, chapter or track.
- 4. STOP (■)**  
Stops disc play.
- 5. PLAY/PAUSE (▶||)**  
Begin or pause disc play.
- 6. EZ VIEW**  
The aspect ratio of a picture can easily be adjusted to your TV's screen size (16:9 or 4:3).
- 7. OPEN/CLOSE (▲)**  
Press to open and close the disc tray.
- 8. DISPLAY**  
Operation indicators are displayed here.
- 9. DISC TRAY**  
Place the disc here.

### Front Panel Display

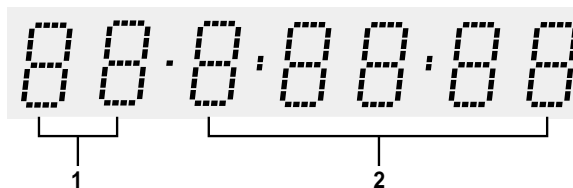

- 1. Chapter/Track number indicator**
- 2. Total playing time/Displays various messages concerning operations such as PLAY, STOP, LOAD ...**  
no DISC: No disc loaded.  
OPEN: The disc tray is open.  
LOAD: Player is loading disc information.

SETUP

**Rear Panel**

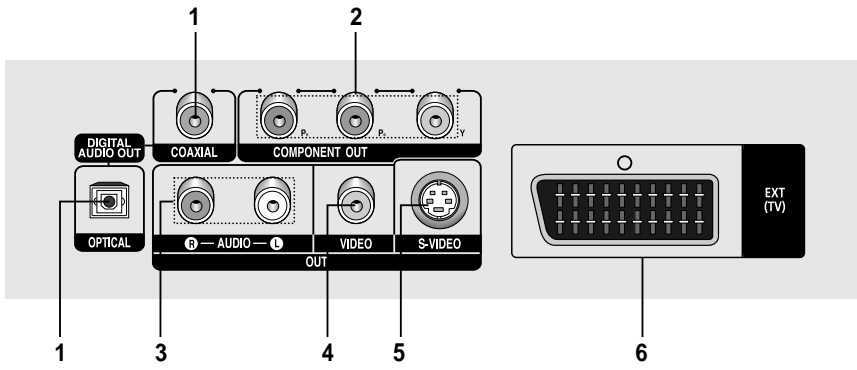

- 1. DIGITAL AUDIO OUT JACKS**
  - Use either an optical or coaxial digital cable to connect to a compatible Dolby Digital receiver.
  - Use either an optical or coaxial digital cable to connect to an A/V Amplifier that contains a Dolby Digital, MPEG2 or DTS decoder.
- 2. COMPONENT VIDEO OUT JACKS**
  - Use these jacks if you have a TV with Component Video in jacks. These jacks provide P<sub>R</sub>, P<sub>B</sub> and Y video.
  - If Component(P-SCAN) Video Output is selected in Setup Menu, progressive scan mode will work.
  - If Component(I-SCAN) Video Output is selected in Setup Menu, interlaced scan mode will work.
- 3. AUDIO OUT JACKS**

Connect to the Audio input jacks of your television or audio/video receiver.
- 4. VIDEO OUT JACK**
  - Use a video cable to connect to the Video input jack on your television.
  - The Video Output in Setup Menu must be set to COMPOSITE/S-VIDEO.
- 5. S-VIDEO OUT JACK**
  - Use the S-Video cable to connect this jack to the S-Video jack on your television for higher picture quality.
  - The Video Output in Setup Menu must be set to COMPOSITE/S-VIDEO.
- 6. SCART JACK**
  - Connect to a TV scart input jack.

- Note**
- Consult your TV User's Manual to find out if your TV supports Progressive Scan (P-SCAN). If Progressive Scan is supported, follow the TV User's Manual regarding Progressive Scan settings in the TV's menu system.
  - If Component (P-SCAN) Video Output is selected in Setup Menu, Video and S-Video Outputs do not work.
  - See pages 53 ~ 54 to get more information on how to use the setup menu.

SETUP

## Tour of the Remote Control

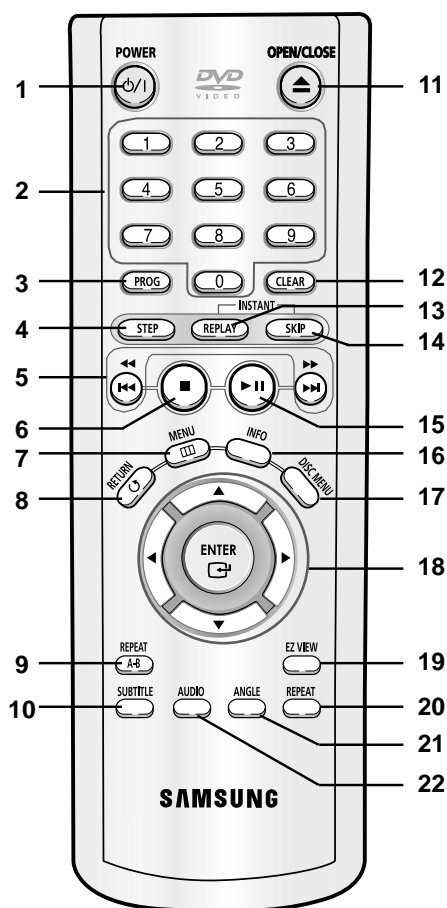

- 1. DVD POWER Button**  
Turns the power on or off.
- 2. NUMBER Buttons**
- 3. PROG Button**  
Allows you to program a specific order.
- 4. STEP Button**  
Advances play one frame at a time.
- 5. SEARCH/SKIP Buttons (◀▶, ◀▶▶)**  
Allow you to search forward/backward through a disc.  
Use to skip the title, chapter or track.
- 6. STOP Button (■)**
- 7. MENU Button**  
Brings up the DVD player's menu.
- 8. RETURN Button**  
Returns to a previous menu.
- 9. REPEAT A-B Button**  
Allows you to repeat play A-B disc.
- 10. SUBTITLE Button**
- 11. OPEN/CLOSE (▲) Button**  
To open and close the disc tray.
- 12. CLEAR Button**  
Use to remove menus or status displays from the screen.
- 13. INSTANT REPLAY Button**  
This function is used to replay the previous 10 seconds of a movie from the current position.
- 14. INSTANT SKIP Button**  
This function skips playback ahead 10 seconds.
- 15. PLAY/PAUSE Button (▶||)**  
Begin/Pause disc play.
- 16. INFO Button**  
Displays the current disc mode.
- 17. DISC MENU Button**  
Brings up the Disc menu.
- 18. ENTER/▲▼◀▶ Buttons**  
This button functions as a toggle switch.
- 19. EZ VIEW Button**  
The aspect ratio of a picture can easily be adjusted according to the screen size of your TV (16:9 or 4:3).
- 20. REPEAT Button**  
Allows you to repeat play a title, chapter, track, or disc.
- 21. ANGLE Button**  
Use to access various camera angles on a DVD.
- 22. AUDIO Button**  
Use this button to access various audio functions on a disc.

# Chapter 2

## CONNECTIONS

### Choosing a Connection

The following shows examples of connections commonly used to connect the DVD player with a TV and other components.

#### Before Connecting the DVD Player

- Always turn off the DVD player, TV, and other components before you connect or disconnect any cables.
- Refer to the user's manual of the additional components (such as a TV) you are connecting for more information on those particular components.

#### Connecting to a TV (SCART)

- Using the SCART, connect the SCART (EXT) terminal on the rear of the DVD Player to the SCART(IN) terminal of your TV.
- If your TV is not equipped with a SCART you can select one of the following alternative connections:

#### Connection to a TV (Video CVBS)

#### 1

Using video/audio cables, connect the **VIDEO (yellow)/AUDIO (red and white) OUT** terminals on the rear of the DVD player to the **VIDEO (yellow)/AUDIO (red and white) IN** terminals of your TV.

#### 2

Turn on the DVD player and TV.

#### 3

Press the input selector on your TV remote control until the Video signal from the DVD player appears on the TV screen.

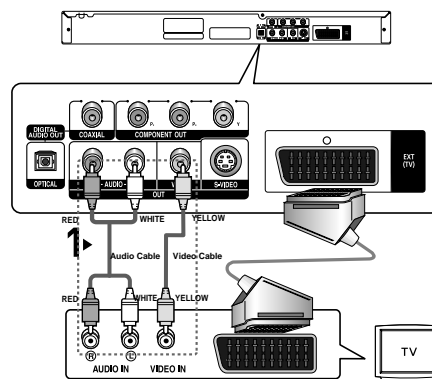

#### Note

- **Noise may be generated if the audio cable placed too close to the power cable.**
- If you want to connect to an Amplifier, please refer to the Amplifier connection page. (See pages 15 to 16)
- The number and position of terminals may vary depending on your TV set. Please refer to the user's manual of your TV.
- If there is one audio input terminal on the TV, connect it to the [AUDIO OUT][left] (white) terminal of the DVD player.



CONNECTIONS

**Connection to a TV (S-Video)**

- Connecting to your TV using an S-Video cable.
- You will enjoy high quality images. S-Video separates the picture element into black and white(Y) and color(C) signals to present clearer images than regular video input mode. (Audio signals are delivered through the audio output.)

**1**  
Using an S-Video cable (not included), connect the **S-VIDEO OUT** terminal on the rear of the DVD player to the **S-VIDEO IN** terminal of your TV.

**2**  
Using the audio cables, connect the **AUDIO (red and white) OUT** terminals on the rear of the DVD player to the **AUDIO (red and white) IN** terminals of your TV.  
Turn on the DVD player and TV.

**3**  
Press the input selector on your TV remote control until the S-Video signal from the DVD player appears on your TV screen.

**4**  
Set the Video Output to **COMPOSITE/S-VIDEO** in the Display Setup menu. (See pages 53 to 54)

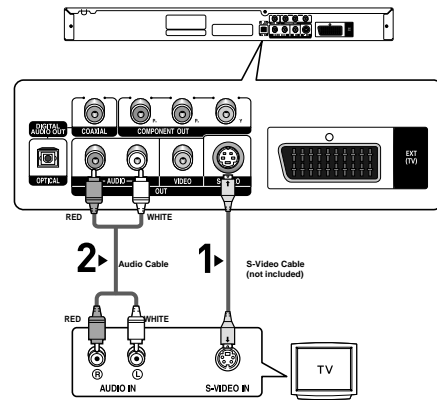

**Note**

- If you want to connect to an Amplifier, please refer to the Amplifier connection page. (See pages 15 to 16)
- The number and position of terminals may vary depending on the TV set. Please refer to the user's manual of your TV.

## CONNECTIONS

### Connection to a TV (Interlace)

- Connecting to your TV using Component video cables.
- You will enjoy high quality and accurate color reproduction images. Component video separates the picture element into black and white(Y), blue(P<sub>B</sub>), red(P<sub>R</sub>) signals to present clear and clean images. (Audio signals are delivered through the audio output.)

#### 1

Using component video cables (not included), connect the **COMPONENT VIDEO OUT** terminals on the rear of the DVD player to the **COMPONENT IN** terminals of your TV.

#### 2

Using the audio cables, connect the **AUDIO (red and white) OUT** terminals on the rear of the DVD player to the **AUDIO (red and white) IN** terminals of your TV. Turn on the DVD player and TV.

#### 3

Press the input selector on your TV remote control until the Component signal from the DVD player appears on the TV screen.

#### 4

Set the Video Output to **Component (I-SCAN)** in the Display Setup menu. (See pages 53 to 54)

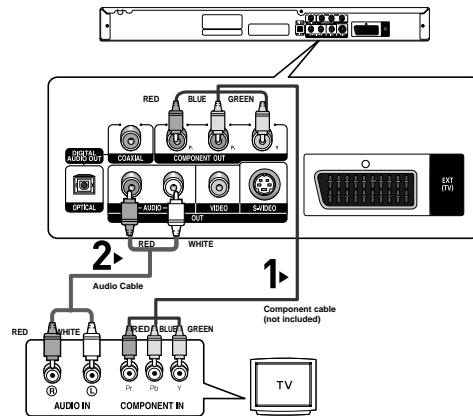

#### Note

- If Video output is incorrectly set to **COMPOSITE/S-VIDEO** with the Component cables connected, the screen will turn red.
- If you want to connect to an Amplifier, please refer to the Amplifier connection page. (See pages 15 to 16)
- The component terminal of your TV may be marked "R-Y, B-Y, Y" or "Cr, Cb, Y" instead of "P<sub>R</sub>, P<sub>B</sub>, Y" depending on the manufacturer. The number and position of terminals may vary depending on the TV set. Please refer to the user's manual of your TV.

CONNECTIONS

**Connection to a TV (Progressive)**

- 1**  
Using component video cables (not included), connect the **COMPONENT VIDEO OUT** terminals on the rear of the DVD player to the **COMPONENT IN** terminals of your TV.
- 2**  
Using the audio cables, connect the **AUDIO (red and white) OUT** terminals on the rear of the DVD player to the **AUDIO (red and white) IN** terminals of your TV. Turn on the DVD player and TV.
- 3**  
Press the input selector on your TV remote control until the Component signal from the DVD player appears on the TV screen.
- 4**  
Set the Video Output to **Component (P-SCAN)** in the Display Setup menu. (See pages 53 to 54)

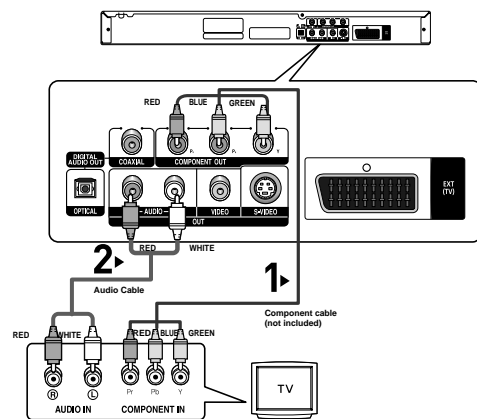

**To see the progressive video output,**

- Consult your TV User's Manual to find out if your TV supports Progressive Scan.
- If Progressive Scan is supported, follow the TV User's Manual regarding Progressive Scan settings in the TV's menu system.
- Depending on your TV, the connection method may differ from the illustration above.

**Note**

- What is "Progressive Scan"?  
Progressive scan has twice as many scanning lines as the interlace output method. Progressive scanning method provides better and clearer picture quality.

CONNECTIONS

**Connection to an Audio System (2 Channel Amplifier)**

- 1**  
Using the audio cables, connect the **AUDIO (red and white) OUT** terminals on the rear of the DVD player to the **AUDIO (red and white) IN** terminals of the Amplifier.
- 2**  
Using the video signal cable(s), connect the **VIDEO, S-VIDEO** or **COMPONENT OUT** terminals on the rear of the DVD player to the **VIDEO, S-VIDEO** or **COMPONENT IN** terminal of your TV as described on pages 11 to 14.
- 3**  
Turn on the DVD player, TV, and Amplifier.
- 4**  
Press the input select button of the Amplifier to select **external input** in order to hear sound from the DVD player. Refer to your Amplifier's user manual to set the Amplifier's audio input.

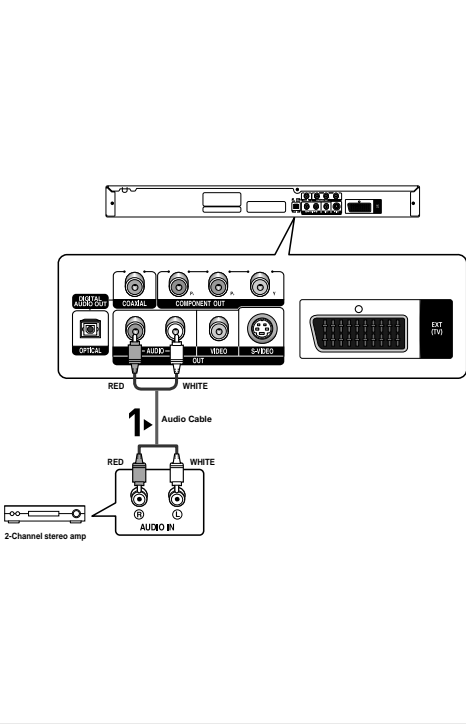

Connections

- Note**
- Please turn the volume down when you turn on the Amplifier. Sudden loud sound may cause damage to the speakers and your ears.
  - Please set the audio in the menu screen according to the Amplifier. (See pages 51 to 52)
  - The position of terminals may vary depending on the Amplifier. Please refer to the user's manual of the Amplifier.

## CONNECTIONS

### Connection to an Audio System (Dolby digital, MPEG2 or DTS Amplifier)

#### 1

If using an optical cable (not included), connect the **DIGITAL AUDIO OUT (OPTICAL)** terminal on the rear of the DVD player to the **DIGITAL AUDIO IN (OPTICAL)** terminal of the Amplifier.  
If using a coaxial cable (not included), connect the **DIGITAL AUDIO OUT (COAXIAL)** terminal on the rear of the DVD player to the **DIGITAL AUDIO IN (COAXIAL)** terminal of the Amplifier.

#### 2

Using the video signal cable(s), connect the **VIDEO**, **S-VIDEO** or **COMPONENT OUT** terminals on the rear of the DVD player to the **VIDEO**, **S-VIDEO** or **COMPONENT IN** terminal of your TV as described on pages 11 to 14.

#### 3

Turn on the DVD player, TV, and Amplifier.

#### 4

Press the input select button of the Amplifier to select **external input** in order to hear sound from the DVD player.  
Refer to your Amplifier's user manual to set the Amplifier's audio input.

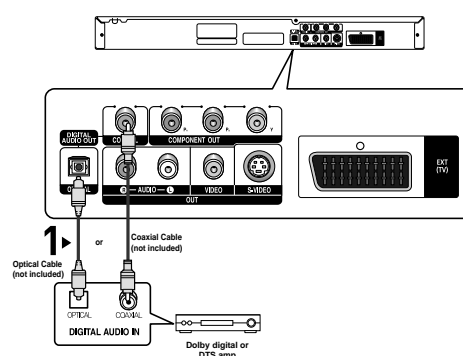

#### Note

- When you connect the DVD player to DTS Amplifier and play a DTS disc, set the DTS to On in Audio Setup menu. If it is set to Off, sound will not be heard, or there will be a loud sound.
- Please turn the volume down when you turn on the Amplifier. Sudden loud sound may cause damage to the speakers and your ears.
- Please set the audio in the menu screen according to the Amplifier. (See pages 51 to 52)
- The position of terminals may vary depending on the Amplifier. Please refer to the user's manual of the Amplifier.

# Chapter 3

## BASIC FUNCTIONS

### Playing a Disc

#### Before Play

- Turn on your TV and set it to the correct Video Input on the TV's remote control.
- If you connected an external Audio System, turn on your Audio System and set it to the correct Audio Input.

After plugging in the player, the first time you press the DVD **POWER** button, this screen comes up: If you want to select a language, press a **NUMBER** button. (This screen will only appear when you plug in the player for the first time.)  
 If the language for the startup screen is not set, the settings may change whenever you turn the power on or off. Therefore, make sure that you select the language you want to use.  
 Once you select a menu language, you can change it by pressing the **▶▶** button on the front panel of the unit for more than 5 seconds with no disc in the unit. Then the **SELECT MENU LANGUAGE** window appears again where you can reset your preferred language.



Basic Functions

#### Playback

**1**  
 Press the **OPEN/CLOSE** (▲) button.  
 The **STANDBY** indicator light goes out and the tray opens.

**2**  
 Place a disc gently into the tray with the disc's label facing up.

**3**  
 Press the **PLAY/PAUSE** (▶||) button or **OPEN/CLOSE** (▲) button to close the disc tray.

◀ **RESUME function**  
 When you stop disc play, the player remembers where you stopped, so when you press **PLAY/PAUSE** (▶||) button again, it will pick up where you left off. (unless the disc is removed or the player is unplugged, or if you press the **STOP** (■) button twice.)

BASIC FUNCTIONS

**4**  
**Stopping Play**  
 Press the **STOP (■)** button during play.

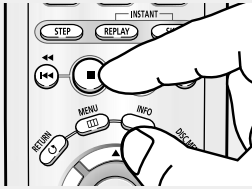

- Note**
- If the player is left in the stop mode for more than one minute without any user interaction, a screen saver will be activated. Press the PLAY/PAUSE (▶||) button to resume normal play.
  - If the player is left in the stop mode for more than 30 minutes, the power will automatically turn off. (Automatic Power-Off Function)

**5**  
**Removing Disc**  
 Press the **OPEN/CLOSE (▲)** button.

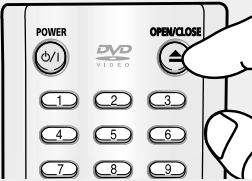

**6**  
**Pausing Play**  
 Press the **PLAY/PAUSE (▶||)** or **STEP** button on the remote control during play.

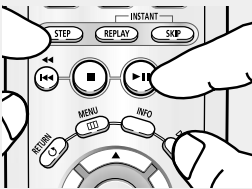

- ◀ Screen stops, no sound. To resume, press the PLAY/PAUSE (▶||) button once again.

**7**  
**Step Motion Play (Except CD)**  
 Press the **STEP** button on the remote control during play.

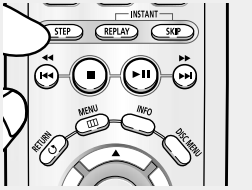

- Note**
- If the player is left for about 5 minutes in pause mode, it will stop.
  - ◀ Each time the button is pressed, a new frame will appear. No sound is heard during STEP mode. Press the PLAY/PAUSE (▶||) button to resume normal play. You can only perform step motion play in the forward direction.

**8**  
**Slow Motion Play (Except CD)**  
 Press and hold the **SEARCH (▶▶)** button to choose the play speed between 1/8, 1/4 and 1/2 of normal during PAUSE or STEP mode.

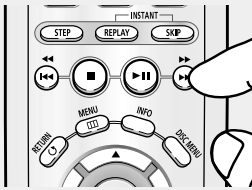

- ◀ No sound is heard during slow mode. Press the PLAY/PAUSE (▶||) button to resume normal play. Reverse slow motion play will not work.
- Note**
- This (⊘) icon indicates an invalid button press.

BASIC FUNCTIONS

## Using the Search and Skip Functions

During play, you can search quickly through a chapter or track, and use the skip function to jump to the next selection.

### Searching through a Chapter or Track

During play, press the **SEARCH** (◀◀ or ▶▶) button on the remote control for more than 1 second.

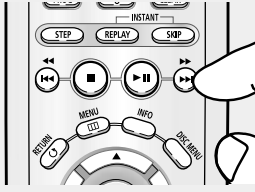

◀ If you want to search at a faster speed on the DVD, VCD or CD, press and hold the button.

DVD	2X, 8X, 32X, 128X
VCD	4X, 8X
CD	2X, 4X, 8X

**Note**

- The speed marked in this function may be different from the actual playback speed.
- No sound is hearing during search mode (Except CD).

### Skipping Tracks

During play, press the **SKIP** (◀◀ or ▶▶) button.

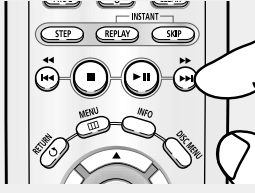

- When playing a DVD, if you press the SKIP (▶▶) button, it moves to the next chapter. If you press the SKIP (◀◀) button, it moves to the beginning of the chapter. One more press makes it move to the beginning of the previous chapter.
- When playing a VCD 2.0 in Menu Off mode, or a VCD 1.1 or a CD, if you press the SKIP (▶▶) button, it moves to the next track. If you press the SKIP (◀◀) button, it moves to the beginning of the track. One more press makes it move to the beginning of the previous track.
- If a track exceeds 15 minutes when playing a VCD and you press the ▶▶ button, it moves forward 5 minutes. If you press the ◀◀ button, it moves backward 5 minutes.

**Note**

When playing VCD 2.0, this function works only when the menu is off.

Basic Functions



BASIC FUNCTIONS

## Using the Display Function

### When Playing a DVD/VCD/CD/MPEG4

**1**  
During play, press the **INFO** button on the remote control.

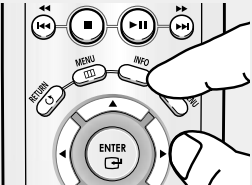

◀ You can select Info in the function menu by pressing the MENU button.

**2**  
Press the ▲/▼ buttons to select the desired item.

**DVD**



**VCD**

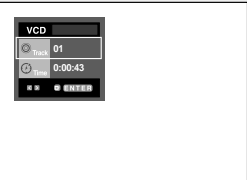

**CD**



**MPEG4**



◀ When playing VCD 2.0, this function works only when the menu is off.

**BASIC FUNCTIONS**

**3**  
Press the ◀▶ buttons to make the desired setup and then press the **ENTER** button.

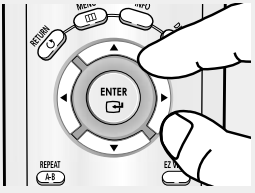





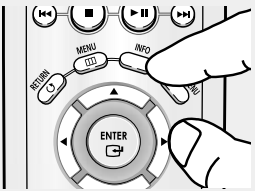

◀ You may use the number buttons of the remote control to directly access a title, chapter or to start the playback from a desired time.

**4**  
To make the screen disappear, press the **INFO** button again.



**Basic Functions**

**Note**

 <b>Title</b>	To access the desired title when there is more than one in the disc. For example, if there is more than one movie on a DVD, each movie will be identified.
 <b>Chapter</b>  <b>Track</b>	Most DVD discs are recorded in chapters so that you can quickly find a specific passage (similar to tracks on an audio CD).
 <b>Time</b>	Allows playback of the film from a desired time. You must enter the starting time as a reference. The time search function does not operate on some discs.
 <b>Audio</b>	Refers to the film's soundtrack language. In the example, the soundtrack is played in English 5.1CH. A DVD disc can have up to eight different soundtracks. The MP3, AC3 and WMA are supported.(DivX)
 <b>Subtitle</b>	Refers to the subtitle languages available in the disc. You will be able to choose the subtitle languages or, if you prefer, turn them off from the screen. A DVD disc can have up to 32 different subtitles.
 <b>Size</b>	(DivX) File Size has a relationship with resolution of a title. The larger file size is, the higher resolution is displayed. If the file resolution is small, it scales up automatically. So you can see the larger screen.

BASIC FUNCTIONS

## Using the Disc and Title Menu

### Using the Disc Menu (DVD)

**1**  
During the playback of a DVD disc, press the **MENU** button on the remote control.

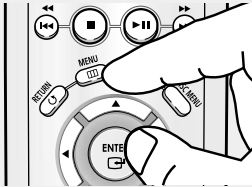

**2**  
Press the ▲/▼ buttons to select **Disc Menu**, then press the ► or **ENTER** button.



**Note**

- Depending on a disc, the Disc Menu may not work.
- You can also use the Disc Menu, using the DISC MENU button on the remote control.
- In VCD 2.0 the DISC MENU button is used to select Menu On or Menu Off mode.

### Using the Title Menu (DVD)

**1**  
During the playback of a DVD disc, press the **MENU** button on the remote control.

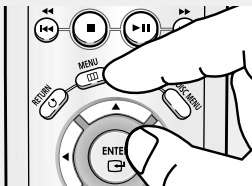

**2**  
Press the ▲/▼ buttons to select **Title Menu**, then press the ► or **ENTER** button.



**Note**

- Depending on a disc, the Title Menu may not work.
- Title Menu will only be displayed if there are at least two titles in the disc.

BASIC FUNCTIONS

## Using the Function Menu

### Using the Function Menu (DVD/VCD)

**1**  
Press the **MENU** button during playback.

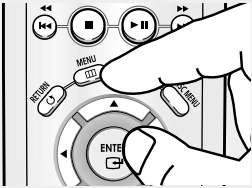

**2**  
Press the **▲/▼** buttons to select **Function**, then press the **▶** or **ENTER** button.

- Info (See pages 20 to 21)
- Zoom (See page 34)
- Bookmark (See pages 32 to 33)
- Repeat (See pages 24 to 25)
- EZ View (See pages 27 to 28)



**3**  
Press the **▲/▼** buttons to select one of the five functions. Then press the **▶** or **ENTER** button to access the function.

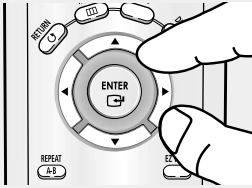

◀ You can also directly select these functions using their respective buttons on the remote control.

- INFO
- EZ VIEW
- REPEAT

Basic Functions

BASIC FUNCTIONS

## Repeat Play

Repeat the current track, chapter, title, a chosen section (A-B), or all of the disc.

### When playing a DVD/VCD/CD

**1**  
Press the **REPEAT** button on the remote control. Repeat screen appears.

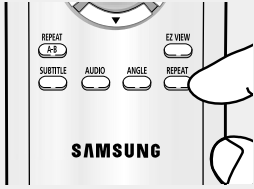

**2**  
Press the **◀▶** buttons to select **Chapter**, **Title**, or **A-B**, then press the **ENTER** button.

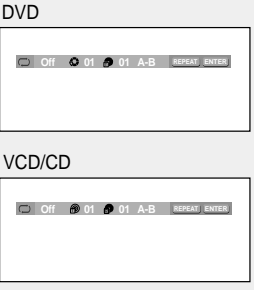

- ◀ DVD repeats play by chapter or title, CD and VCD repeat play by disc or track.
- Chapter (📀): repeats the chapter that is playing.
- Title (🎵): repeats the title that is playing.
- Disc (📀): repeats the disc that is playing.
- Track (🎵): repeats the track that is playing.
- A-B: repeats a segment of the disc that you select.

### Using the A-B Repeat function

1. Press the REPEAT A-B button at the point where you want repeat play to start (A). B is automatically highlighted.
2. Press the REPEAT A-B button at the point where you want the repeat play to stop (B).
  - To return to normal play, press the CLEAR button.

### Note

A-B REPEAT does not allow you to set point (B) until at least 5 seconds of playback time has elapsed after point (A) has been set.

**3**  
To return to normal play, press **REPEAT** button again, then press the **◀▶** buttons to select **Off** and press **ENTER** button.

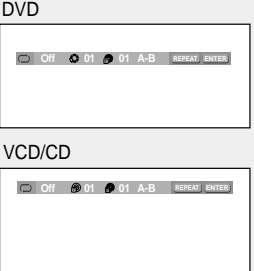

### Note

- Depending on a disc, the Repeat function may not work.
- When playing VCD 2.0, this function works only when the menu is off.

**BASIC FUNCTIONS**

**Slow Repeat Play**

This feature allows you slowly to repeat scenes containing sports, dancing, musical instruments being played etc., so you can study them more closely.

**When playing a DVD/VCD**

**1**  
During play, press the **PLAY/PAUSE (▶||)** button.

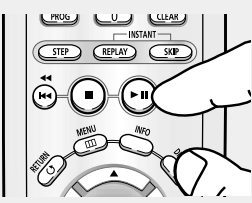

**2**  
Press and hold the **SEARCH (▶▶)** button to choose the play speed between 1/8, 1/4 and 1/2 of normal during PAUSE or STEP mode.

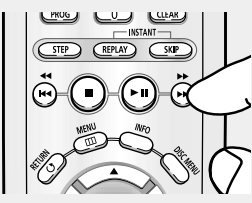

**3**  
Press the **REPEAT** button on the remote control. Press the **◀▶** buttons to select **A-B**.

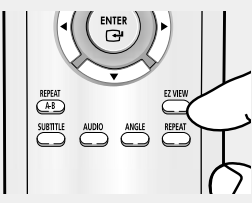

◀ The disc will play from A to B repeatedly at the speed you chose.

**4**  
Press the **ENTER** button at the point where you want repeat play to start (A). **B** is automatically highlighted. Press the **ENTER** button at the point where you want the repeat play to stop (B).

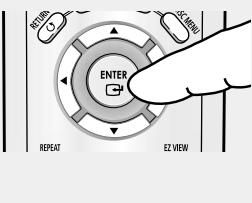

◀ To set A-B REPEAT, set (A) first, then set (B) after the following slow play time has elapsed:  
1/8x: wait 40 seconds, then press B  
1/4x: wait 20 seconds, then press B  
1/2x: wait 10 seconds, then press B

**5**  
To return to normal play, press the **CLEAR** button and then press the **PLAY/PAUSE (▶||)** button.

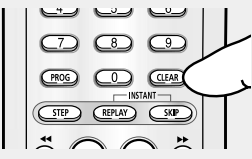

**Note**  
When playing VCD 2.0, this function works only when the menu is off.

Basic Functions

BASIC FUNCTIONS

## Program Play & Random Play

### Program Play (CD)

Program Play allows you to select the order in which you want tracks to play.

**1**  
During play, press the **PROG** button.

**2**  
Press the ◀▶ buttons to select **PROGRAM**.  
Press the **ENTER** button.

**3**  
Press the ▲▼/◀▶ buttons to select the first track to add to the program.  
Press the **ENTER** button.  
The selection numbers appear in the Program Order box.

Track		Program Order	
01	02 03 04	--	-- --
05	06 07 08	--	-- --
09	10 11 12	--	-- --
13	14 15 16	--	-- --

- ◀ - To return to the previous menu screen, press the RETURN button.
- To cancel the selected program order, press the CLEAR button.
- This unit can support a maximum of 20 programmed tracks.

**4**  
Press the **PLAY/PAUSE** (▶||) button.  
The disc will be played in programmed order.

### Random Play (CD)

Random Play plays a disc's tracks in random order.

**1**  
Press the **PROG** button.

**2**  
Press the ◀▶ buttons to select **RANDOM**.  
Press the **ENTER** button.

**Note**

- Depending on a disc, the Program and Random Play functions may not work.
- While in playback mode, press the CLEAR button on the remote control to cancel Program Play or Random Play.

# Chapter 4

## ADVANCED FUNCTIONS

### Adjusting the Aspect Ratio (EZ View)

#### To play back using aspect ratio (DVD)

Press the **EZ VIEW** button.

- The screen size changes when the button is pressed repeatedly.
- The screen zoom mode operates differently depending on the screen setting in the Display Setup menu.
- To ensure correct operation of the **EZ VIEW** button, you should set the correct aspect ratio in the Display Setup menu. (See pages 52 to 53).

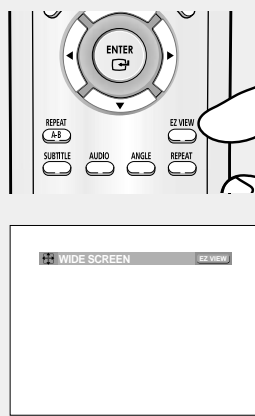

The diagram shows a remote control with buttons labeled REPEAT, A-B, SUBTITLE, AUDIO, ANGLE, REPEAT, EZ VIEW, and ENTER. Below the remote is a screen display showing a 'WIDE SCREEN' bar at the top with 'EZ VIEW' on the right side.

◀ To make the aspect ratio bar disappear, press the CLEAR button.

Advanced Functions

#### If you are using a 16:9 TV

<p><b>For 16:9 aspect ratio discs</b></p> <ul style="list-style-type: none"> <li>- <b>WIDE SCREEN</b> Displays the content of the DVD title in 16:9 aspect ratio.</li> <li>- <b>SCREEN FIT</b> The top and bottom portions of the screen are cut off. When playing a 2.35:1 aspect ratio disc, the black bars at the top and bottom of the screen will disappear. The picture will look vertically stretched. (Depending on a type of disc, the black bars may not disappear completely.)</li> <li>- <b>ZOOM FIT</b> The top, bottom, left and right of the screen are cut off and the central portion of the screen is enlarged.</li> </ul>	<p><b>For 4:3 aspect ratio discs</b></p> <ul style="list-style-type: none"> <li>- <b>Normal Wide</b> Displays the content of the DVD title in 16:9 aspect ratio. The picture will look horizontally stretched.</li> <li>- <b>SCREEN FIT</b> The top and bottom portions of the screen are cut off and the full screen appears. The picture will look vertically stretched.</li> <li>- <b>ZOOM FIT</b> The top, bottom, left and right portions of the screen are cut off and the central portion of the screen is enlarged.</li> <li>- <b>Vertical Fit</b> When a 4:3 DVD is viewed on a 16:9 TV, black bars will appear at the left and right of the screen in order to prevent the picture from looking horizontally stretched.</li> </ul>
--	--



ADVANCED FUNCTIONS
--------------------

**If you are using a 4:3 TV****For 16:9 aspect ratio discs**

- **4:3 Letter Box**  
Displays the content of the DVD title in 16:9 aspect ratio.  
The black bars will appear at the top and bottom of the screen.
- **4:3 Pan Scan**  
The left and right portions of the screen are cut off and the central portion of the 16:9 screen is displayed.
- **SCREEN FIT**  
The top and bottom portions of the screen are cut off and a full screen appears.  
The picture will look vertically stretched.
- **ZOOM FIT**  
The top, bottom, left and right of the screen are cut off and the central portion of the screen is enlarged.

**For 4:3 aspect ratio discs**

- **Normal Screen**  
Displays the content of the DVD title in 4:3 aspect ratio.
- **SCREEN FIT**  
The top and bottom portions of the screen are cut off and the full screen appears.  
The picture will look vertically stretched.
- **ZOOM FIT**  
The top, bottom, left and right portions of the screen are cut off and the central portion of the screen is enlarged.

**Note**

This function may behave differently depending on the type of disc.

ADVANCED FUNCTIONS

## Selecting the Audio Language

You can select a desired audio language quickly and easily with the AUDIO button.

### Using the AUDIO button (DVD/VCD/CD/MPEG4)

**1**  
Press the **AUDIO** button. The Audio changes when the button is pressed repeatedly.  
- The audio languages are represented by abbreviations.

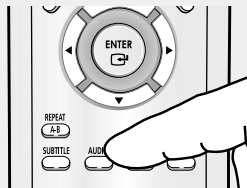

**DVD**



**VCD/CD**



When playing a VCD or CD, you can select among **Stereo, Right or Left**.

**MPEG4**



Press the ◀▶ buttons to select the desired Audio on a MPEG4 then press the **ENTER**.

**2**  
To remove the **AUDIO** icon, press the **CLEAR** or **RETURN** button.

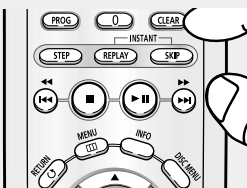
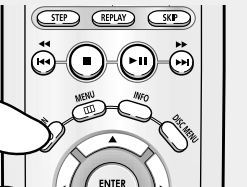
**Note**

- This function depends on audio languages are encoded on the disc and may not work.
- A DVD disc can contain up to 8 audio languages.
- To have the same audio language come up whenever you play a DVD; Refer to "Using the Audio Language" on page 48.

Advanced Functions

ADVANCED FUNCTIONS

## Selecting the Subtitle Language

You can select a desired subtitle quickly and easily with the SUBTITLE button.

### Using the SUBTITLE button (DVD/MPEG4)

**1**  
 Press the **SUBTITLE** button.  
 The subtitle changes when the button is pressed repeatedly.  
 The subtitle languages are represented by abbreviations.



DVD  
 — OFF — SUBTITLE

MPEG4  
 — NONE — ENTER

Press the ◀▶ buttons to select the desired subtitle language on a MPEG4 then press the **ENTER** .

**2**  
 To remove the **SUBTITLE** icon, press the **CLEAR** or **RETURN** button.



**Note**

- Depending on DVDs, you have to change the desired subtitle in the Disc Menu. Press the DISC MENU button.
- This function depends on what subtitles are encoded on the disc and may not work on all DVDs.
- A DVD disc can contain up to 32 subtitle languages.
- To have the same subtitle language come up whenever you play a DVD; Refer to "Using the Subtitle Language" on page 49.

ADVANCED FUNCTIONS

## Changing the Camera Angle

When a DVD contains multiple angles of a particular scene, you can use the ANGLE function.

### Using the ANGLE button (DVD)

If the disc contains multiple angles, the ANGLE appears on the screen.

**1**

Press the **ANGLE** button, then the ANGLE icon will appear with the current angle number and the number of angles available.

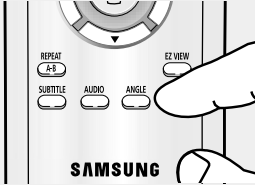

**2**

Press the **ANGLE** button repeatedly to select the desired angle. To remove the ANGLE icon, press the **CLEAR** or **RETURN** button.



**Note**  
If the disc has only one angle, this feature won't work. Currently, very few discs have this feature.

Advanced Functions

## Using the Instant Replay/Skip Function

### Using the Instant Replay function (DVD)

If you miss a scene, you can see it again using this function.

Press the **INSTANT REPLAY** button.

- The current scene moves backward about 10 seconds, and plays back.

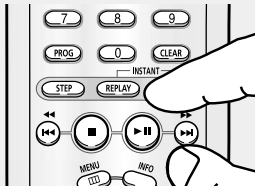

### Using the Instant Skip function (DVD)

Use this function to skip playback about 10 seconds ahead of the current scene.

Press the **INSTANT SKIP** button.

- Playback will skip ahead 10 seconds.

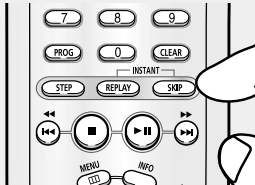

**Note**  
Depending on the disc, these functions may not work.

ADVANCED FUNCTIONS

## Using the Bookmark Function

This feature lets you bookmark sections of a DVD or VCD (Menu Off mode) so you can quickly find them at a later time.

### Using the Bookmark Function (DVD/VCD)

**1**  
During play, press the **MENU** button on the remote control.

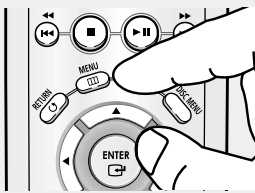

**2**  
Press the ▲/▼ buttons to select **Function**, then press the ► or **ENTER** button.

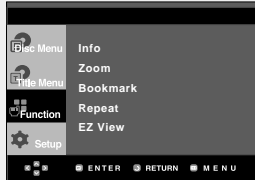

**3**  
Press the ▲/▼ buttons to select **Bookmark**, then press the ► or **ENTER** button.



**4**  
When you reach the scene you want to mark, press the **ENTER** button. Up to three scenes may be marked at a time.

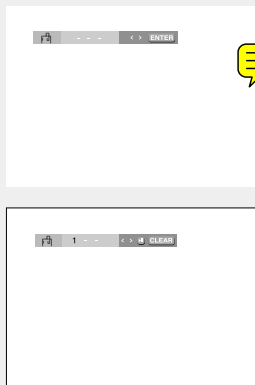

**Note**

- When playing VCD 2.0, this function works only when the menu is off.
- Depending on a disc, the Bookmark function may not work.

## ADVANCED FUNCTIONS

### Recalling a Marked Scene

**1~3**  
The first 1~3 steps are the same as those for "Using the Bookmark Function" on page 32.

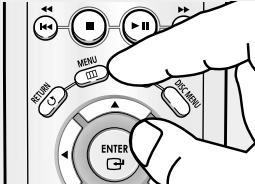

**4**  
Press the ◀▶ buttons to select a marked scene.

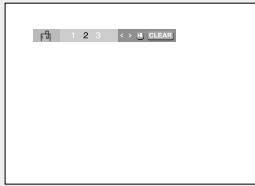

**5**  
Press the **PLAY/PAUSE** (▶||) button to skip to the marked scene.

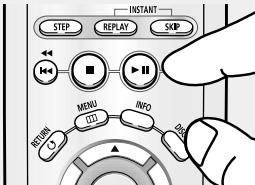

### Clearing a Bookmark

**1~3**  
The first 1~3 steps are the same as those for "Using the Bookmark Function" on page 32.

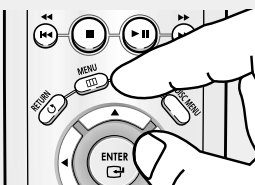

**4**  
Press the ◀▶ buttons to select the bookmark number you want to delete.



**5**  
Press the **CLEAR** button to delete a bookmark number.

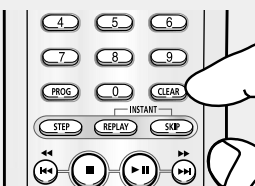

Advanced Functions

ADVANCED FUNCTIONS

## Using the Zoom Function

### Using the Zoom Function (DVD/VCD)

**1**  
During play or pause mode, press the **MENU** button on the remote control.

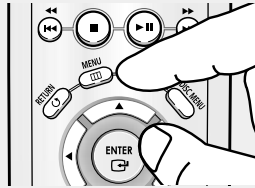

**2**  
Press the ▲/▼ buttons to select **Function**, then press the ► or ENTER button.



**3**  
Press the ▲/▼ buttons to select **Zoom**, then press the ► or ENTER button.

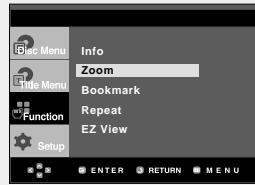

**4**  
Press the ▲/▼ or ◀▶ buttons to select the part of the screen you want to zoom in on. Press the **ENTER** button.

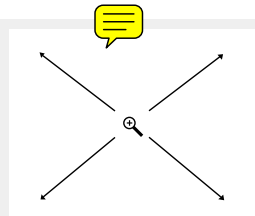

◀ During DVD play, press ENTER to zoom in 2X/4X/2X/Normal in order.  
During VCD play, press ENTER to zoom in 2X/Normal in order.

**Note**  
When playing VCD 2.0, this function works only when the menu is off.

ADVANCED FUNCTIONS

## DVD AUDIO Playback

**1**  
 Open the disc tray.  
 Place the DVD AUDIO disc on the tray.  
 - Place the DVD AUDIO disc with the labeled side up.  
 Close the tray.  
 - The tray closes and disc plays.

**2**  
 During play, press the **INFO** button on the remote control.

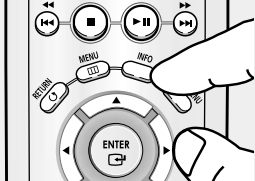

◀ You can select Info in the function menu by pressing the MENU button.

**3**  
 Press the ▲/▼ buttons to select the desired item.

DVD-AUDIO



◀ When playing VCD 2.0, this function works only when the menu is off.

**4**  
 Press the ◀▶ buttons to make the desired setup and then press the **ENTER** button.

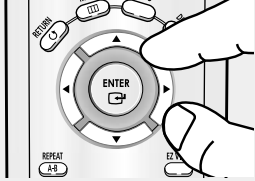

◀ You may use the number buttons of the remote control to directly access a Group, Track, Page or to start the playback from the desired time.

**5**  
 To make the screen disappear, press the **INFO** button again.

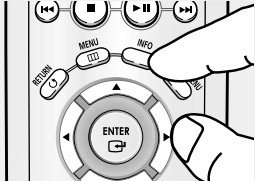







Advanced Functions



ADVANCED FUNCTIONS

**Note**

 Group	(DVD-AUDIO) Most DVD AUDIO discs are recorded in Groups you can change Groups with this Function. Bonus Group playback. Some DVD AUDIO discs have Bonus groups. If you want to play a Bonus group, you must enter the Bonus Group code. The code is usually on the DVD AUDIO disc case.
 Track	(DVD-AUDIO) To access the desired Track when there is more than one on the DVD AUDIO disc.
 Page	(DVD-AUDIO) If pages are included with the DVD-AUDIO disc, you can see this icon. To access the desired page, you can use this Function.
 Slide	(DVD-AUDIO) If a slide show is included with the DVD-AUDIO disc, you can see this icon.
 V-zone	(DVD-AUDIO) If a video zone is included with the DVD-AUDIO disc, you can see this icon.
 Time	(DVD-AUDIO) Allows playback of music from a desired time by using the number buttons.

**Page, Index Function**

**1**

Use Page icon of display function to Skip the Page when there is more than one in a group.

- Some DVD-AUDIO discs include a slide show. In the slide show mode, this function can not be used.
- PAGE is still images. You can see the still images when a DVD-AUDIO disc is played back.

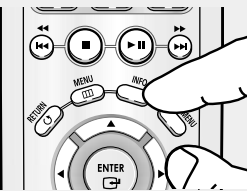

**Note**

Depending on a disc, this function may not work.

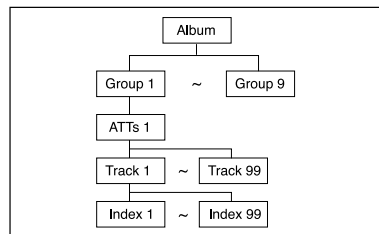

ADVANCED FUNCTIONS

**REPEAT Play**

**1**  
Press the **REPEAT** button on the remote control. Repeat screen appears.

**2**  
Press the ◀▶ buttons to select **Title**, **Group**, then press the **ENTER** button.

◀ Title (🎯): repeats the title that is playing.  
 Group (🎯): repeats the group that is playing.

**AUDIO Format Display**

**1**  
During DVD AUDIO playback, press the **AUDIO** button to see AUDIO Format information.

◀ - **LPCM** : **L**inear **P**ulse **C**ode **M**odulation.  
 Not compressed Audio data format.  
 - **PPCM** : **P**acket **P**ulse **C**ode **M**odulation.  
 Lossless compressed Audio data format.

**Note**  
 Some DVD-AUDIO discs don't allow audio down-mixing.

Advanced Functions

ADVANCED FUNCTIONS

### Clips Menu for MP3/WMA/JPEG/MPEG4

Discs with MP3/WMA/JPEG/MPEG4 contain individual songs and/or pictures that can be organized into folders as shown below. They are similar to how you use your computer to put files into different folders.

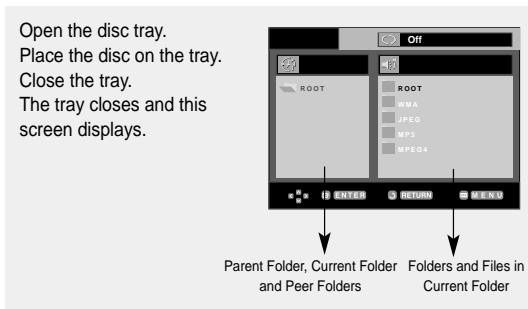

- : Name of currently playing file.
- : MP3 file icon.
- : Current Playback Time.
- : WMA file icon.
- : Current Playback Mode : There are four modes. They can be selected in order by pressing the **REPEAT** button.
- : JPEG file icon.
- Off: Normal Playback
- Track: Repeats the current track.
- Folder: Repeats the current folder.
- Random: Files in the disc will be played in random order.
- : AVI file icon.
- : Folder icon.
- : Current Folder icon.

### Folder Selection

The folder can only be selected in the Stop mode.

- **To select the Parent Folder**  
Press the **RETURN** button to go to the parent folder, or press the **▲/▼** buttons to select "." and press **ENTER** to go to the parent folder.
- **To select the Peer Folder**  
Press the **◀/▶** buttons to highlight the left window. Press the **▲/▼** buttons to select the desired folder, then press **ENTER**.
- **To select the Sub-Folder**  
Press the **◀/▶** buttons to highlight the right window. Press the **▲/▼** buttons to select the desired folder, then press **ENTER**.

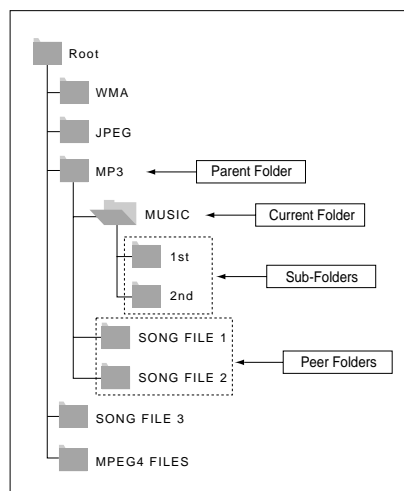

ADVANCED FUNCTIONS

## MP3/WMA Playback

- 1**  
 Open the disc tray.  
 Place the disc on the tray.  
 Close the tray.

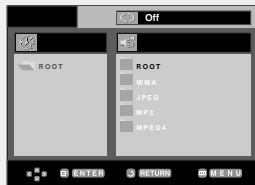

- 2**  
 Press the ▲/▼ or ◀/▶ buttons to select a song file.  
 Press **ENTER** to begin playback of the song file.

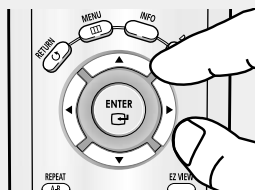

◀ When a disc that contains both MP3 and WMA files, only one type will play, not both.

Advanced Functions

## Repeat/Random playback

- 1**  
 Press the **REPEAT** button to change the playback mode.  
 There are four modes: **Off**, **Track**, **Folder** and **Random**.

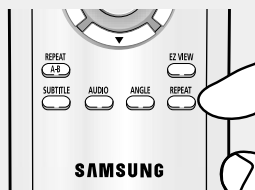

- Off: Normal Playback
- Track: Repeats the current song file.
- Folder: Repeats the song files which have the same extension in the current folder.
- Random: Song files which have the same extension will be played in random order.

To resume normal play, press the **CLEAR** button.

## ADVANCED FUNCTIONS

### CD-R MP3/WMA file

**When you record MP3 or WMA files on CD-R, please refer to the following.**

**- Your MP3 or WMA files should be ISO 9660 or JOLIET format.**

ISO 9660 format and Joliet MP3 or WMA files are compatible with Microsoft's DOS and Windows, and with Apple's Mac. This format is the most widely used.

**- When naming your MP3 or WMA files, do not exceed 8 characters, and enter ".mp3, .wma" as the file extension.**

General name format : Title.mp3. or Title.wma. When composing your title, make sure that you use 8 characters or less, have no spaces in the name, and avoid the use of special characters including: (,./\,=,+).

**- Use a decompression transfer rate of at least 128 Kbps when recording MP3 files.**

Sound quality with MP3 files basically depends on the rate of compression/decompression you choose. Getting CD audio sound requires an analog/digital sampling rate, that is conversion to MP3 format, of at least 128 Kbps and up to 160 Kbps. However, choosing higher rates, like 192 Kbps or more, only rarely give better sound quality. Conversely, files with decompression rates below 128 Kbps will not be played properly.

**- Use a decompression transfer rate of at least 64Kbps when recording WMA files.**

Sound quality with WMA files basically depends on the rate of compression/decompression you choose. Getting CD audio sound requires an analog/digital sampling rate, that is conversion to WMA format, of at least 64Kbps and up to 192Kbps. Conversely, files with decompression rates below 64Kbps or over 192Kbps will not be played properly.

**- Do not try recording copyright protected MP3 files.**

Certain "secured" files are encrypted and code protected to prevent illegal copying. These files are of the following types: Windows Media™ (registered trade mark of Microsoft Inc) and SDMI™ (registered trade mark of The SDMI Foundation). You cannot copy such files.

**- Important:**

The above recommendations cannot be taken as a guarantee that the DVD player will play MP3 recordings, or as an assurance of sound quality. You should note that certain technologies and methods for MP3 file recording on CD-Rs prevent optimal playback of these files on your DVD player (degraded sound quality and in some cases, inability of the player to read the files).

- This unit can play a maximum of 3000 files and 300 folders per disc.

## ADVANCED FUNCTIONS

### MPEG4 Playback

#### MPEG4 Play Function

AVI files are used to contain the audio and video data. Only AVI format files with the ".avi" extensions can be played.

**1**

Open the disc tray.  
Place the disc on the tray.  
Close the tray.

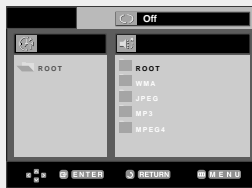

**2**

Press the ▲/▼ or ◀/▶ buttons to select an avi file (DivX/XviD), then press the ENTER button.

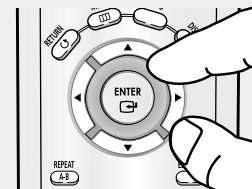

Advanced  
Functions

#### Repeat Playback

**1**

Press the REPEAT button to change playback mode. There are 4 modes, such as **Off**, **Folder**, **Title** and **A-B** (a distance between two points appointed by user).

- Folder : Repeats the AVI files which have the same extension in the current folder.
- Title : repeats the title that is playing.
- A-B : repeats a segment of the file that you select.

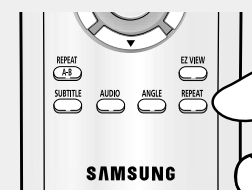

**ADVANCED FUNCTIONS**

**MPEG4 Function Description**

Function	Description	Reference page
Skip ( ◀◀ or ▶▶ )	During play, press the  ◀◀ or ▶▶  button, it moves forward or backward 5 minutes.	-
Search (◀◀ or ▶▶)	During play, press the SEARCH (◀◀ or ▶▶) button and press again to search at a faster speed. Allows you to search at a faster speed in an AVI file. (2X, 4X, 8X)	-
Slow Motion Play	Allows you to search at a slower speed in an AVI file. (1/8X, 1/4X, 1/2X)	P 18
Step Motion Play	Each time the STEP button is pressed, a new frame will appear.	P 18
ZOOM	2X/4X/2X/Normal in order	P 34

- These functions may not work depending on MPEG4 file.

**CD-R AVI file**

This unit can play the following video compression formats within the AVI file format:

- DivX 3.11 contents
- DivX 4 contents (Based on MPEG4 Simple Profile)
- DivX 5 contents (MPEG4 simple profile plus additional features such as bi-directional frames. Qpel and GMC are also supported.)
- XviD MPEG4 compliant Contents.

This unit supports all resolutions up to maximum below.

DivX3.11 & DivX4 & XviD	DivX5
Bitrate may fluctuate: Device may skip decoding the high bitrate portions and begin decoding again when Bitrate returns to normal.	720 x 480 @30fps 720 x 576 @25fps : Maximum bitrate : 4Mbps

**Note**

- Some MPEG4 files created on a personal computer may not be play back.  
That is why Codec Type, Version and Higher resolution over specification is not supported.
- This unit supports CD-R/RW written in MPEG4 in accordance with the "ISO9660 format".

ADVANCED FUNCTIONS

## Picture CD Playback

**1**  
Select the desired folder.

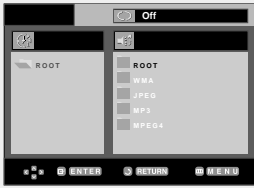

**2**  
Press the ▲/▼ buttons to select a Picture file in the clips menu and then press the ENTER button.



**3**  
Press the INFO button to display the menu. Press the ◀▶ buttons to select the menu you want to view, then press the ENTER button.

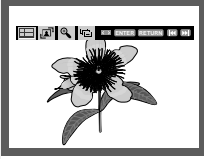

- Note**
- If no buttons on the remote control are pressed for 10 seconds, the menu will disappear.
  - Press the STOP button to return to the clips menu.
  - When playing a Kodak Picture CD, the unit displays the Photo directly, not the clips menu.

### Album Screen

-  : Returns to the Album Screen.
- To see the next six pictures, press the ▶▶ button.
- To see the previous six pictures, press the ◀◀ button.

### Rotation

-  : Each time the ENTER button is pressed, the picture rotates 90 degrees clockwise.

### Zoom





-  : Press the ▲/▼ or ◀▶ buttons to select the part of the screen you want to zoom in on. Press the ENTER button. Each time the ENTER button is pressed, the picture is enlarged up to 4X. (2X → 4X → 2X → Normal)

**Note**

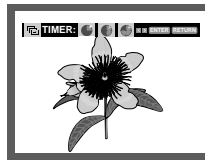
- Depending on a file size, the amount of time between each picture may be different from the set interval time.
- If you don't press any button, the slide show will start automatically in about 10 seconds by default.

### Slide Show



-  : The unit enters slide show mode.
- Before beginning the Slide Show, the picture interval must be set. Press the ◀▶ buttons to select a desired icon, then press the ENTER button.
-  : The pictures change automatically with about a 6 second interval.
-  : The pictures change automatically with about a 12 second interval.
-  : The pictures change automatically with about a 18 second interval.



## ADVANCED FUNCTIONS

### CD-R JPEG Discs

- Only files with the ".jpg" and ".JPG" extensions can be played.
- If the disc is not closed, it will take longer to start playing and not all of the recorded files may be played.
- Only CD-R discs with JPEG files in ISO 9660 or Joliet format can be played.
- The name of the JPEG file may not be longer than 8 characters and should contain no blank spaces or special characters (. / = +).
- Only a consecutively written multi-session disc can be played. If there is a blank segment in the multi-session disc, the disc can be played only up to the blank segment.
- A maximum of 3000 images can be stored on a single CD.
- Kodak Picture CDs are recommended.
- When playing a Kodak Picture CD, only the JPEG files in the pictures folder can be played.
- Kodak Picture CD: The JPEG files in the pictures folder can be played automatically.
- Konica Picture CD: If you want to see the Picture, select the JPEG files in the clips menu.
- Fuji Picture CD: If you want to see the Picture, select the JPEG files in the clips menu.
- QSS Picture CD: The unit may not play QSS Picture CD.
- If the number of files in 1 Disc is over 3000, only 3000 JPEG files can be played.
- If the number of folders in 1 Disc is over 300, only JPEG files in 300 folders can be played

# Chapter 5

## CHANGING SETUP MENU

### Using the Setup Menu

The Setup menu lets you customize your DVD player by allowing you to select various language preferences, set up a parental level, even adjust the player to the type of television screen you have.

**1**

With the unit in Stop mode, press the **MENU** button on the remote control.

Press the **▲/▼** buttons to select **Setup**, then press the **▶** or **ENTER** button.



- ❶ Language Setup : Setup of the Language.
- ❷ Audio Setup : Setup of the Audio Options.
- ❸ Display Setup : Setup of the Display Options. Use to select which type of screen you want to watch and several display options.
- ❹ Parental Setup : Setup of the Parental Level. Allows users to set the level necessary to prevent children from viewing unsuitable movies such as those with violence, adult subject matter, etc.
- ❺ DivX(R) Registration : Please use the Registration code to register this player with the DivX(R) Video On Demand format. To learn more go to [www.divx.com/vod](http://www.divx.com/vod).

**2**

Press the **▲/▼** buttons to access the different features. Press the **▶** or **ENTER** button to access the sub features.

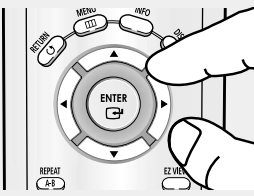

**3**

To make the setup screen disappear after setting up, press the **MENU** button again.

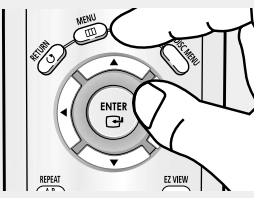

**Note**  
Depending on the disc, some Setup Menu selections may not work.

Changing Setup Menu

CHANGING SETUP MENU

## Setting Up the Language Features

If you set the player menu, disc menu, audio and subtitle language in advance, they will come up automatically every time you watch a movie.

### Using the Player Menu Language

**1**

With the unit in Stop mode, press the **MENU** button.

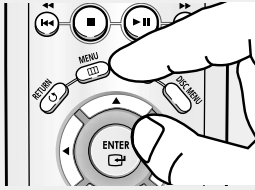

**2**

Press the ▲/▼ buttons to select **Setup**, then press the ► or **ENTER** button.



**3**

Press the ▲/▼ buttons to select **Language Setup**, then press the ► or **ENTER** button.

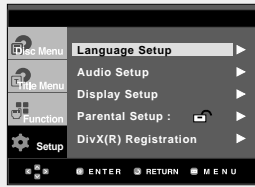

**4**

Press the ▲/▼ buttons to select **Player Menu**, then press the ► or **ENTER** button.

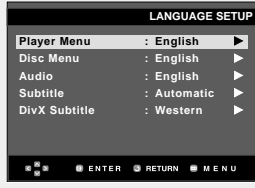

**5**

Press the ▲/▼ buttons to select the desired language, then press the ► or **ENTER** button.



- ◀ - The language is selected and the screen returns to Language Setup menu.
- To make the setup menu disappear, press the MENU button.

## CHANGING SETUP MENU

### Using the Disc Menu Language

This function changes the text language only on the disc menu screens.

**1**  
With the unit in Stop mode, press the **MENU** button.

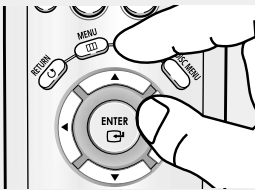

**2**  
Press the ▲/▼ buttons to select **Setup**, then press the ► or **ENTER** button.



**3**  
Press the ▲/▼ buttons to select **Language Setup**, then press the ► or **ENTER** button.



**4**  
Press the ▲/▼ buttons to select **Disc Menu**, then press the ► or **ENTER** button.

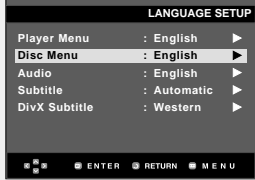

**5**  
Press the ▲/▼ buttons to select the desired language, then press the ► or **ENTER** button.



- ◀ - Select "Others" if the language you want is not listed.
- If the selected language is not recorded on the disc, the original pre-recorded language is selected.
- The language is selected and the screen returns to Language Setup menu.
- To make the setup menu disappear, press the MENU button.

Changing Setup Menu

## CHANGING SETUP MENU

### Using the Audio Language

**1**  
With the unit in Stop mode, press the **MENU** button.

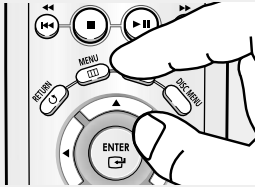

**2**  
Press the ▲/▼ buttons to select **Setup**, then press the ► or **ENTER** button.



**3**  
Press the ▲/▼ buttons to select **Language Setup**, then press the ► or **ENTER** button.

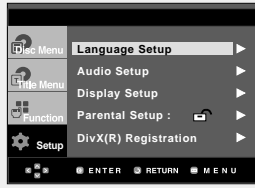

**4**  
Press the ▲/▼ buttons to select **Audio**, then press the ► or **ENTER** button.



**5**  
Press the ▲/▼ buttons to select the desired language, then press the ► or **ENTER** button.



- ◀ - Select "Original" if you want the default soundtrack language to be the original language the disc is recorded in.
- Select "Others" if the language you want is not listed.
- If the selected language is not recorded on the disc, the original pre-recorded language is selected.
- The language is selected and the screen returns to Language Setup menu.
- To make the setup menu disappear, press the MENU button.

## CHANGING SETUP MENU

### Using the Subtitle Language

**1**  
With the unit in Stop mode, press the **MENU** button.

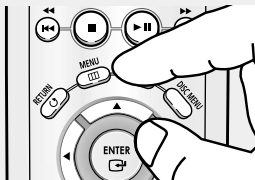

**2**  
Press the ▲/▼ buttons to select **Setup**, then press the ► or **ENTER** button.



**3**  
Press the ▲/▼ buttons to select **Language Setup**, then press the ► or **ENTER** button.



**4**  
Press the ▲/▼ buttons to select **Subtitle**, then press the ► or **ENTER** button.



**5**  
Press the ▲/▼ buttons to select the desired language, then press the ► or **ENTER** button.

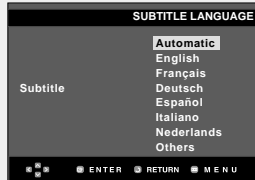

- ◀ - Select "Automatic" if you want the subtitle language to be the same as the language selected as the audio language.
- Select "Others" if the language you want is not listed. Some discs may not contain the language you select as your initial language; in that case the disc will use its original language setting.
- The language is selected and the screen returns to setup menu.
- To make the setup menu disappear, press the MENU button.

Changing Setup Menu

## CHANGING SETUP MENU

### Using the DviX Subtitle Language

**1**  
With the unit in Stop mode, press the **MENU** button.



**2**  
Press the ▲/▼ buttons to select **Setup**, then press the ► or **ENTER** button.



**3**  
Press the ▲/▼ buttons to select **Language Setup**, then press the ► or **ENTER** button.



**4**  
Press the ▲/▼ buttons to select **DivX Subtitle**, then press the ► or **ENTER** button.



**5**  
Press the ▲/▼ buttons to select the desired language, then press the ► or **ENTER** button.



- ◀ - The language is selected and the screen returns to setup menu.
- To make the setup menu disappear, press the **MENU** button.

Western	English, Breton, Catalan, Danish, Dutch, Faroese, Finnish, French, Gaelic, German, Icelandic, Irish, Italian, Norwegian, Portuguese, Spanish and Swedish
Central	English, Albanian, Croatian, Czech, Hungarian, Polish, Romanian, Slovak, Slovene and Serbian(Latin)
Greek	English and modern Greek
Cyrillic	English, Russian, Bulgarian, Belorussian, Macedonian, Moldavian, Serbian(Cyrillic), Ukrainian

## CHANGING SETUP MENU

### Setting Up the Audio Options

Audio Options allows you to setup the audio device and sound status settings depending on the audio system in use.

- 1**  
With the unit in Stop mode, press the **MENU** button.

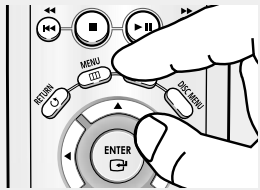

- 2**  
Press the ▲▼ buttons to select **Setup**, then press the ► or **ENTER** button.



- 3**  
Press the ▲▼ buttons to select **Audio Setup**, then press the ► or **ENTER** button.



- 4**  
Press the ▲▼ buttons to select the desired item, then press the ► or **ENTER** button.

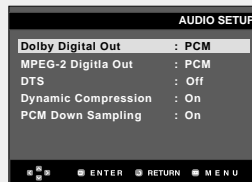

◀ To make the setup menu disappear, press the **MENU** button.

Changing Setup Menu



CHANGING SETUP MENU
---------------------

**❶** Dolby Digital Out

- PCM : Converts to PCM(2CH) audio.
- Bitstream : Outputs Dolby Digital Bitstream via digital output.  
Select Bitstream when connecting to a Dolby Digital Decoder.

**Note**

- There is no analog audio output when you play a DTS disc.

**❷** MPEG-2 Digital Out

- PCM : Converts to PCM(2CH) audio.
- Bitstream : Converts to MPEG-2 Digital Bitstream (5.1CH or 8CH).  
Select Bitstream when using the Digital Audio Output.

**❸** DTS

- Off : Doesn't output digital signal.
- On : Outputs DTS Bitstream via digital output only.  
Select DTS when connecting to a DTS Decoder.

**❹** Dynamic Compression

- On : To select dynamic compression.
- Off : To select the standard range.

**❺** PCM Down Sampling

- On : Select this when the Amplifier connected to the player is not 96KHz compatible.  
In this case, the 96KHz signals will be down converted to 48KHZ.
- Off : Select this when the Amplifier connected to the player is 96KHz compatible.  
In this case, all signals will be output without any changes.

**Note**

Even when PCM Down sampling is Off

- Some discs will only output down sampled audio through the digital outputs.

Manufactured under license from Dolby Laboratories. "Dolby" and the double-D symbol are trademarks of Dolby Laboratories.

"DTS" and "DTS Digital Out" are trademarks of Digital Theater Systems, Inc.

CHANGING SETUP MENU

## Setting Up the Display Options

Display options enable you to set various video functions of the player.

**1**  
With the unit in Stop mode, press the **MENU** button.

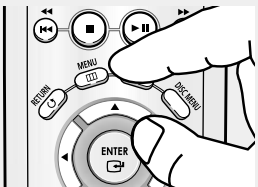

**2**  
Press the ▲/▼ buttons to select **Setup**, then press the ► or **ENTER** button.



**3**  
Press the ▲/▼ buttons to select **Display Setup**, then press the ► or **ENTER** button.



**4**  
Press the ▲/▼ buttons to select the desired item, then press the ► or **ENTER** button.

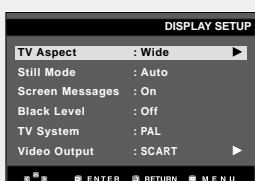

◀ To make the setup menu disappear, press the **MENU** button.

Changing Setup Menu

## CHANGING SETUP MENU

### 1 TV Aspect

Depending on a type of television you have, you may want to adjust the screen setting (aspect ratio).

- 4:3 Letter Box : Select when you want to see the total 16:9 ratio screen DVD supplies, even though you have a TV with a 4:3 ratio screen. Black bars will appear at the top and bottom of the screen.
- 4:3 Pan Scan : Select this for conventional size TVs when you want to see the central portion of the 16:9 screen. (Extreme left and right side of movie picture will be cut off.)
- 16:9 Wide : You can view the full 16:9 picture on your wide screen TV.



### 2 Still Mode

These options will help prevent picture shake in still mode and display small text clearer.

- Auto : When selecting Auto, Field/Frame mode will be automatically converted.
- Field : Select this feature when the screen shakes in the Auto mode.
- Frame : Select this feature when you want to see small letters more clearly in the Auto mode.

### 3 Screen Messages

Use to turn on-screen messages On or Off.

### 4 Black Level

Adjusts the brightness of the screen. (On or Off) It does not function in Progressive mode.

### 5 TV System

- NTSC : In case of using NTSC disc
- If your TV system only has PAL-Video input, you must choose "PAL". When you choose "PAL", Interlace output format is PAL 60 Hz output.
- If your TV system only has NTSC, input you must choose "NTSC".

- PAL : In case of using PAL disc

- If your TV system only has NTSC-Video input, you must choose "NTSC".
- If your TV system only has PAL input, you must choose "PAL".

### 6 Video Output

Select Video Output.

- COMPOSITE/S-VIDEO : Select when you want to use Video and S-Video Out.
- Component (I-SCAN) : Select when you want to use Component Interlace (525i) Out.
- Component (P-SCAN) : Select when you want to use Component Progressive (525p) Out.
- SCART Output : Select when you want to use Scart Out.
  - RGB : Select when you want to use SCART RGB Out.
  - Video : Select when you want to use SCART Video Out.
- If the Yes/No selection in the Display Setup sub Menu is not made within 10 seconds, the screen returns to the previous menu.

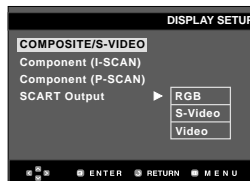
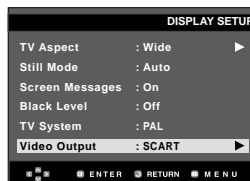

- Consult your TV User's Manual to find out if your TV supports Progressive Scan. If Progressive Scan is supported, follow the TV User's Manual regarding Progressive Scan settings in the TV's menu system.
- If Video Output is set incorrectly, the screen may be blocked.

CHANGING SETUP MENU

## Setting Up the Parental Control

The Parental Control function works in conjunction with DVDs that have been assigned a rating, which helps you control the types of DVDs that your family watches. There are up to 8 rating levels on a disc.

**1**  
With the unit in Stop mode, press the **MENU** button.

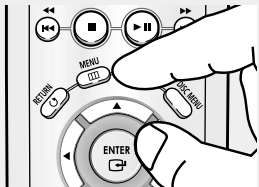

**2**  
Press the ▲/▼ buttons to select **Setup**, then press the ► or **ENTER** button.



**3**  
Press the ▲/▼ buttons to select **Parental Setup**, then press the ► or **ENTER** button.

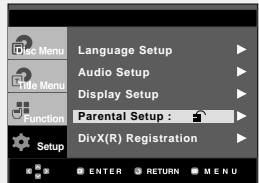

**4**  
Press the ► or **ENTER** button to select **Yes** if you want to use a password. The Enter Password screen appears.

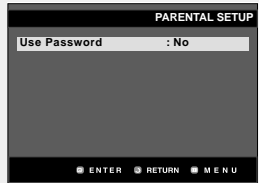

**5**  
Enter your password. The Re-enter Password screen appears to confirm the password. Enter your password again. The player is locked (🔒).

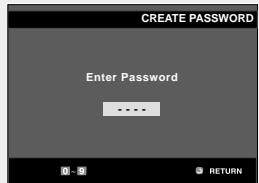
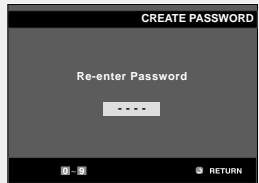
◀ To make the setup menu disappear, press the **MENU** button.

Changing Setup Menu

## CHANGING SETUP MENU

### Setting Up the Rating Level

**1**  
With the unit in Stop mode, press the **MENU** button.

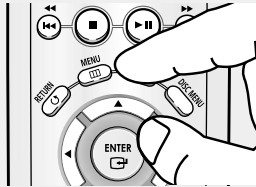

**2**  
Press the ▲/▼ buttons to select **Setup**, then press the ► or **ENTER** button.



**3**  
Press the ▲/▼ buttons to select **Parental Setup**, then press the ► or **ENTER** button.

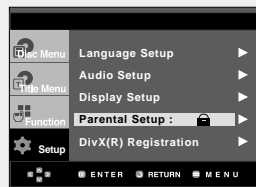

**4**  
Enter your password.



**5**  
Press the ▲/▼ buttons to select **Rating Level**, then press the ► or **ENTER** button.

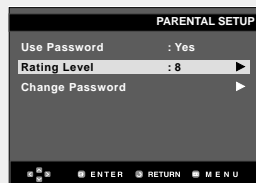

**6**  
Press the ▲/▼ buttons to select the Rating Level you want, then press the ► or **ENTER** button.  
e.g) Setting up in **Level 6**.



◀ To make the setup menu disappear, press the **MENU** button.

For example, if you select up to Level 6, discs that contain Level 7,8 will not play.

## CHANGING SETUP MENU

### Changing the Password

**1**  
With the unit in Stop mode, press the **MENU** button.

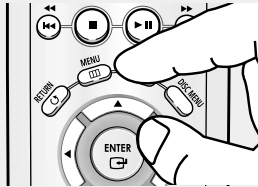

**2**  
Press the ▲/▼ buttons to select **Setup**, then press the ► or **ENTER** button.



**3**  
Press the ▲/▼ buttons to select **Parental Setup**, then press the ► or **ENTER** button. The Enter Password screen appears. Enter your password.

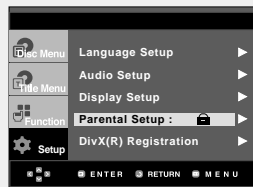

**4**  
Press the ▲/▼ button to select **Change Password**, then press the ► or **ENTER** button. Enter your new password. Re-enter the new password again.

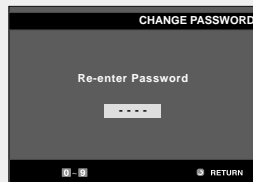
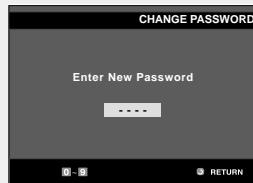
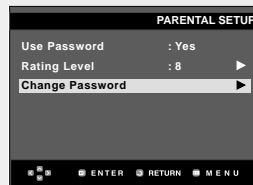

◀ To make the setup menu disappear, press the **MENU** button.

Changing Setup Menu

**Note**  
If you have forgotten your password, see “Forgot Password” in the Troubleshooting Guide.

# 13. Circuit Operating Descriptions

## 13-1 Power

### 13-1-1 Comparison between Linear Power Supply and S.M.P.S.

13-1-1 (a) Linear

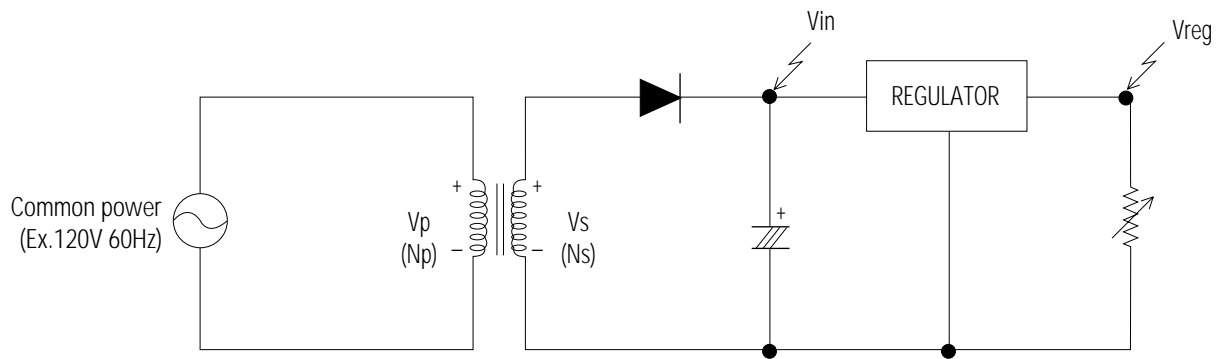

Fig.13-1 Linear Power Supply

◆ Waveform/Description

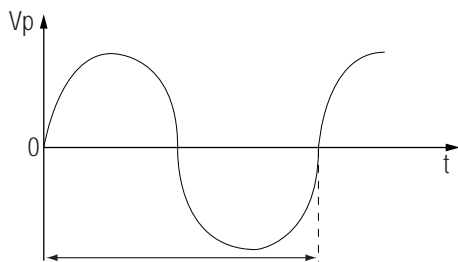

Fig. 13-2

Input : Common power to transformer ( $V_p$ ).

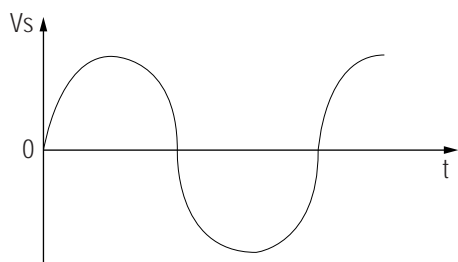

Fig. 13-3

The output  $V_s$  of transformer is determined by the ratio of 1st  $N_p$  and 2nd  $N_s$ .  
 $V_s = (N_s/N_p) \times V_p$

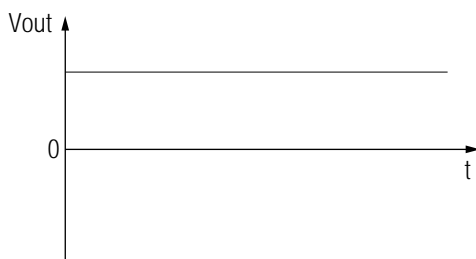

Fig. 13-4

$V_{out}$  is output (DC) by diode and condensor.

◆ Advantages and disadvantages of linear power supply

1) Advantages : Little noise because the output waveform of transformer is sine wave.

2) Disadvantages :

- ❶ Additional margin is required because  $V_s$  is changed (depending on power source). (The regulator loss is caused by margin design).
- ❷ Greater core size and condenser capacity are needed, because the transformer works on a single power frequency.

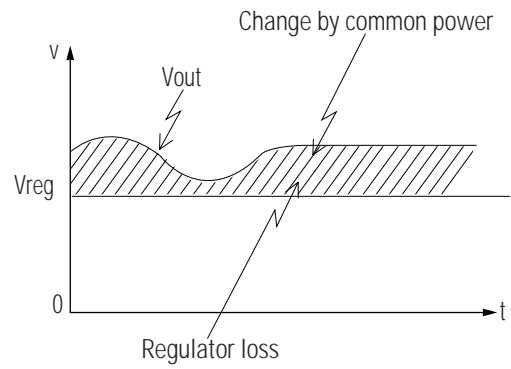

Fig. 13-5

13-1-1 (b) S.M.P.S. (Pulse Width Modulation)

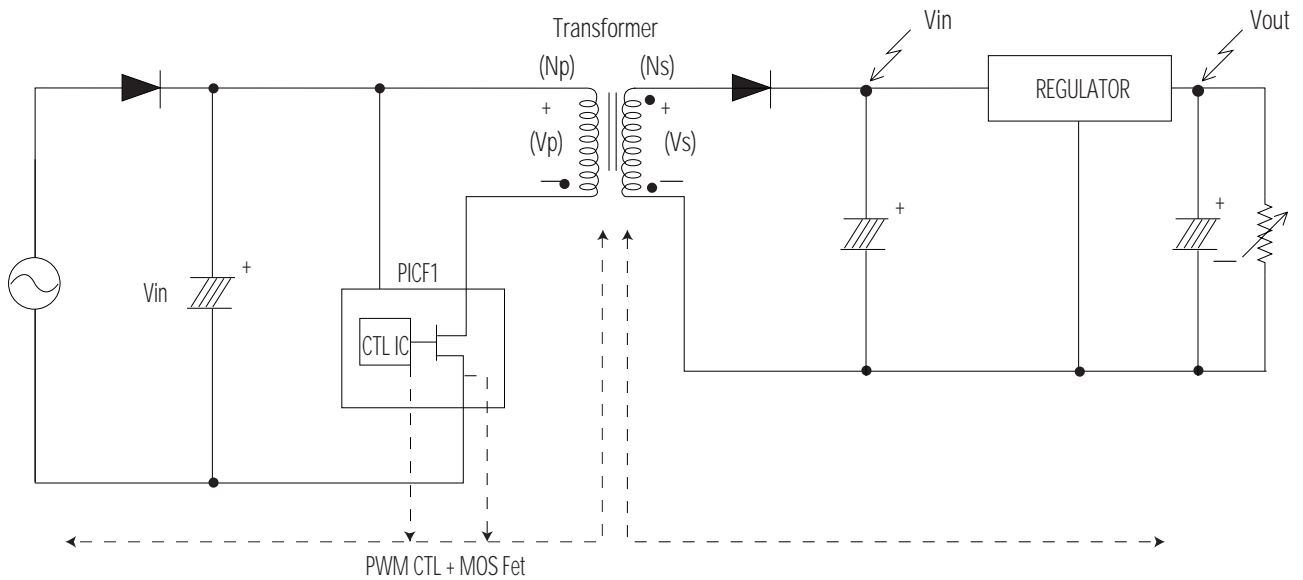

Fig. 13-6

◆ Terms

- 1) 1st : Common power input to 1st winding.
- 2) 2nd : Circuit followings output winding of transformer.
- 3)  $f$  (Frequency) : Switching frequency ( $T$  : Switching cycle)
- 4) Duty :  $(T_{on}/T) \times 100$



### 13-1-2 Circuit description [FLY-Back PWM(Pulse Width Modulation)] Control

#### 13-1-2 (a) AC Power Rectification/Smoothing Terminal

- 1) PDS01, PDS02, PDS03, PDS04 : Convert AC power to DC(Full wave rectification).
- 2) PER10 : Smooth the voltage converted to DC.
- 3) PCD01, PCD02, PBS01 : Noise removal at power input/output.
- 4) PVA1 : SMPS protection at power surge input.

#### 13-1-2 (b) SNUBBER Circuit : PDS11, PCD12, PRS13, PCD11, PPS12

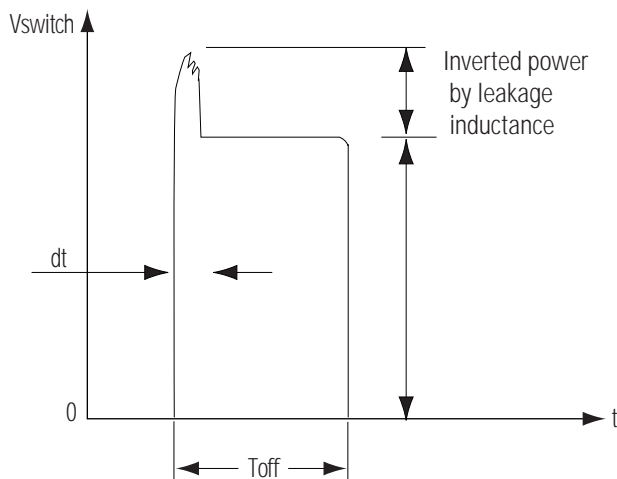

Fig. 13-7

- 1) Prevent residual high voltage at the terminals of switch during switch off/Suppress noise.  
High inverted power occurs at switch (PQR11) off, because of the 1st winding of transformer :  
( $V = -L_1 \frac{di}{dt}$ ,  $L_1$  : Leakage Induction)  
A very high residual voltage exist on both terminals of PIC1 4, 5~8pin because  $dt$  is a very short.
- 2) SNUBBER circuit protects PQR11 from damage through leakage voltage suppression by RC,  
(Charges the leakage voltage to PDS11, PER13, PCD12 and discharges to PRS11, PRS12).

#### 13-1-2 (c) Driving circuit

When  $V_{in}$  supplied, driving current  $I_g$  occurs through the PICF1. By this  $I_1 (=H_{fe} \times I_g)$  occurs through the PIC1 and the  $V_b$  is inducted to base winding coil NB. By inducted  $V_b$ ,  $I_b$  start flow and the  $V_{CC}$  voltage of PQR11 is sustained stable.  $I_b$  is constant and  $I_1$  increases in Proportion to time. After constant time passed  $I_b$  become to shortage and PIC1 is cut OFF (S/W OFF).

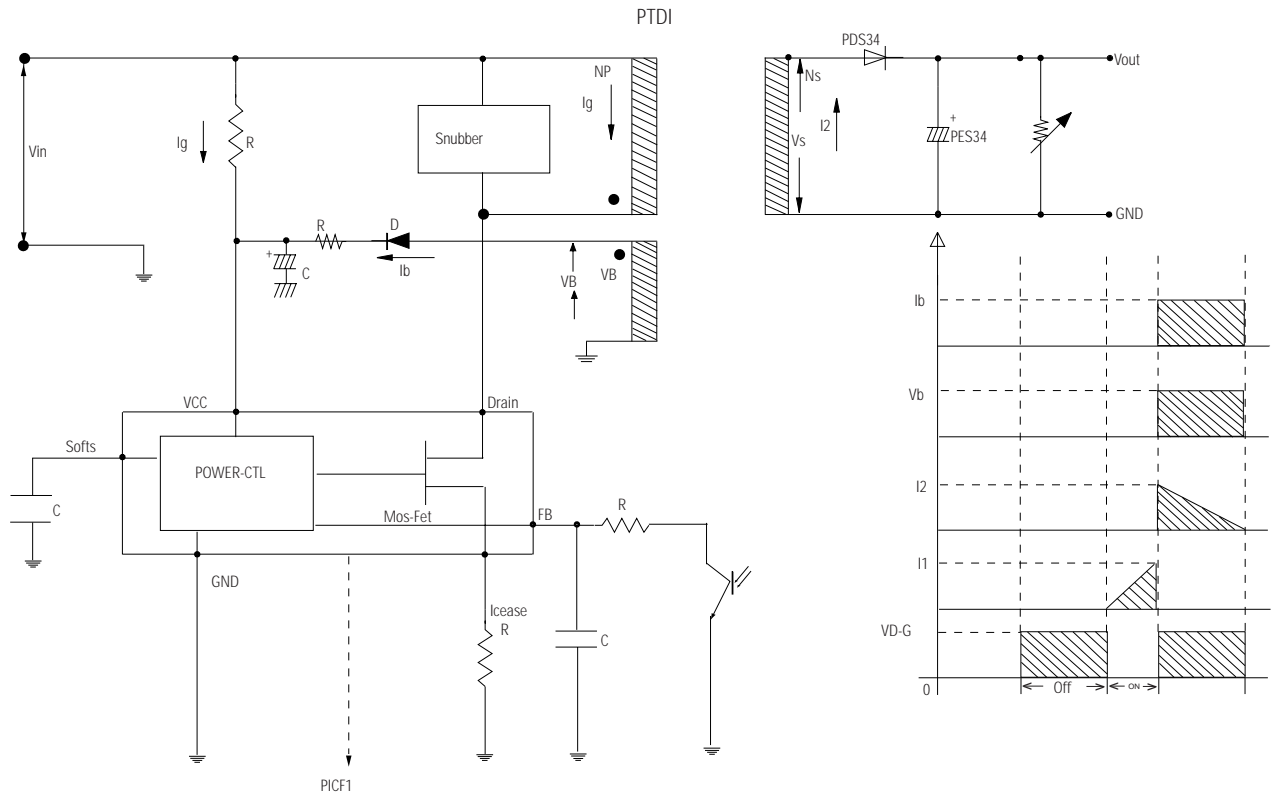

Fig. 13-8 Driving Circuit

## 13-1-2 (d) Feedback Control Circuit

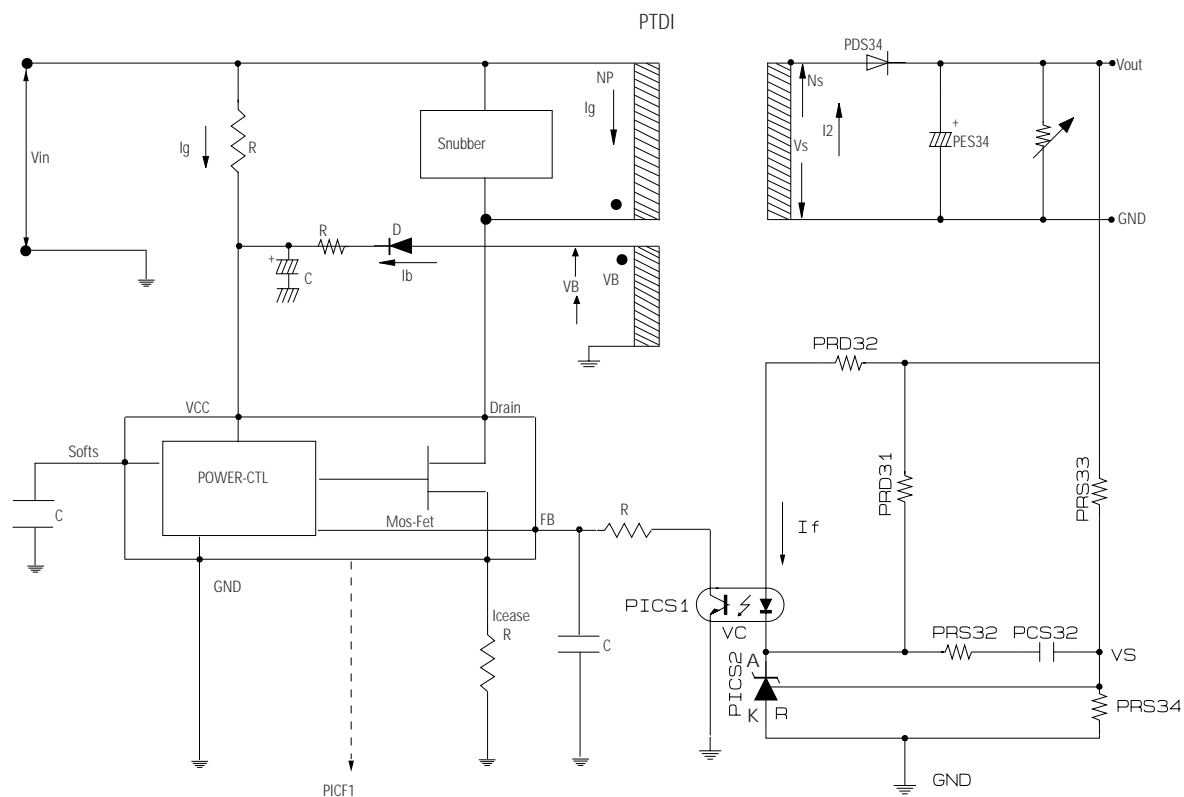

Fig.13-9

## ◆ Operation descriptions

- 1) Internal OP-Amp '+' base potential of PICS2 is 2.5V and external "-" input potential is connected with PRS33 and PRS34 to maintain Vout of 4.4V.
- 2) If load of 4.4V terminal increase (or AC inout voltage decrease) and Vout decrease over 4.4V,  
Then : PICS2 "R" potential decrease over 2.5V --> PICS2 A-K BASE Current decrease --> PICS2 A-K Current decrease --> PICS1 DIODE Current decrease --> PICS1 C-E Current decrease --> PICS1 C-E Voltage increase --> PICS1 F-B Voltage increase --> OUT DUTY increase TRANS Primary Current Increase --> TRANS Primary Power increase --> Vout increase --> Vout maintain 4.4V

- PRD31, PRD32 : Reduce 4.4V overshoot.
- PRS32, PCS32 : Prevent PICS2 oscillation (for phase correction).

### 13-1-3 Internal Block Diagram

◆ Internal Block Diagram

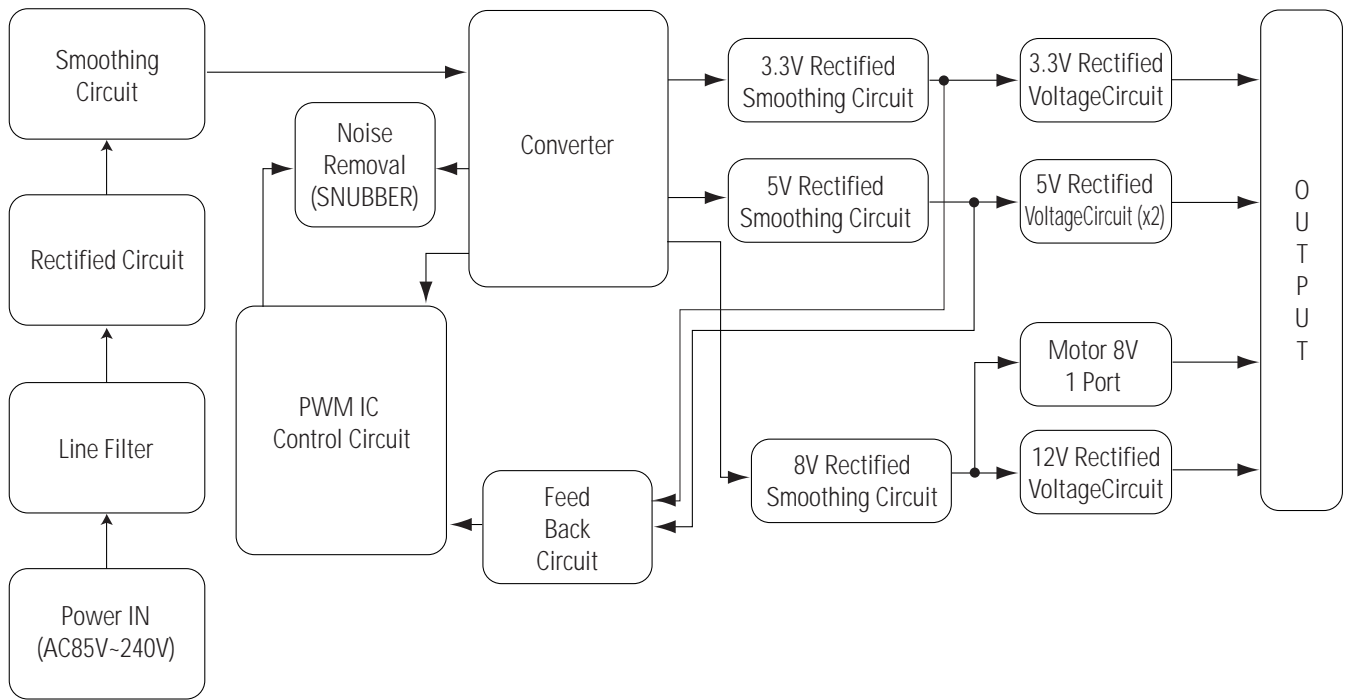

Fig.13-10

## 13-2 RF

### 13-2-1 RIC1 (SP3723)

SP3723 is combined with Zoran Vaddis 6 as bipolar IC developed for DVD SERVO system.

Main features include DVD waveform equalizing, CD waveform equalizing, focus error signal generation, 3-beam tracking error signal generation, DPD 1-beam tracking error, defect, MIRR output, Laser Power Control, etc.

13-2-1 (a) Basic Potentiometer

SP3723 Uses 3.5V to 5.5V and reference voltage is 1.65V.

13-2-1(b) RF signal

Fig. 13-11 shows the flow of signal generated by the pick-up.

RF signal detected from pick-up is converted in to RF signal via RF interface and attenuators.

A, B, C, D signals detected from pick-up are converted in to FE, TE, PI, CE, DEFECT signals.

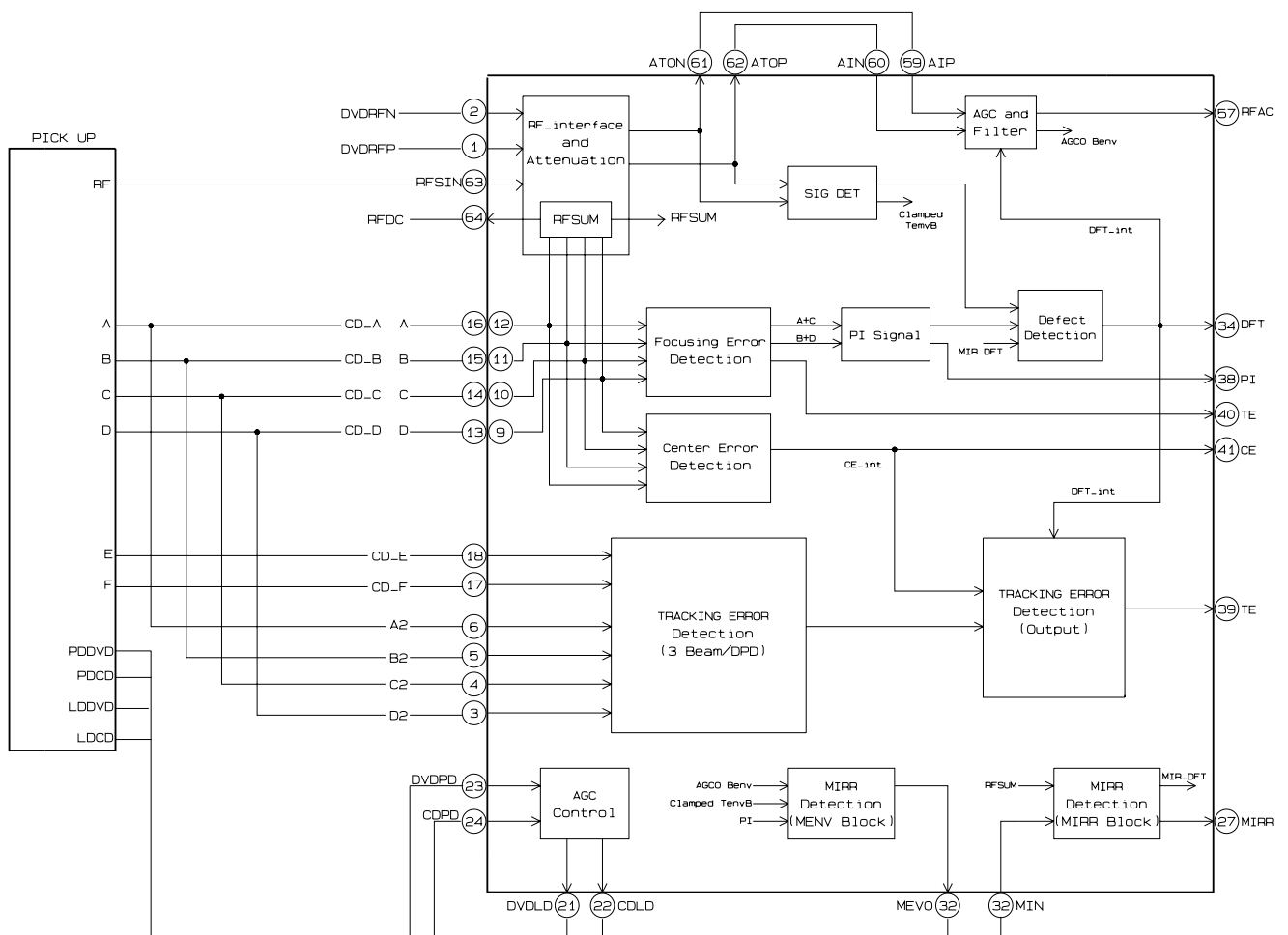

Fig. 13-11

Fig.13-12 shows the waveform-equalizing block diagram for the RF signal.  
RF signal from the pick-up is the input of RF equalizer module of RIC1 (SP3723).

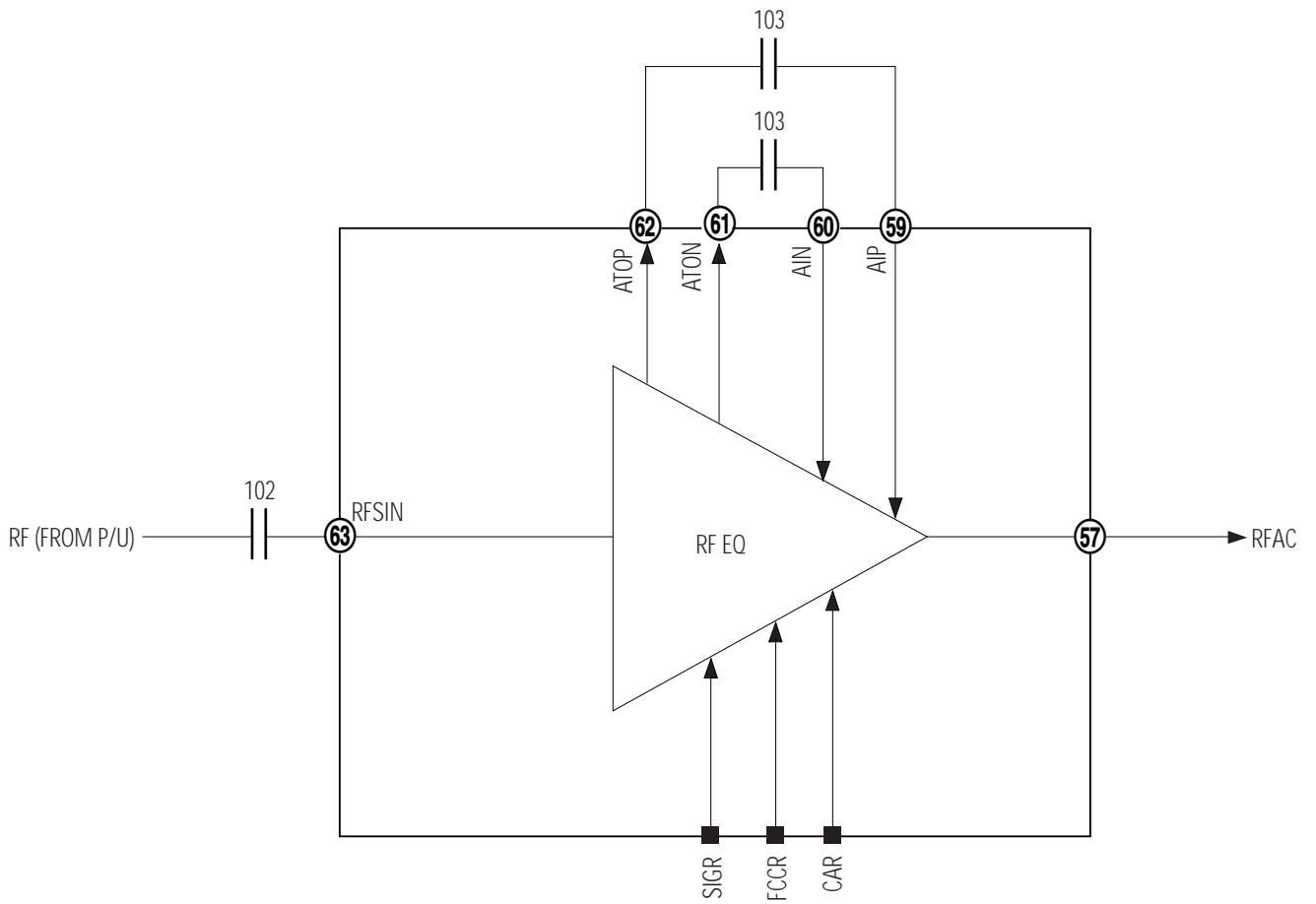

Fig.13-12

### 13-3 System Control

#### 13-3-1 Outline

The main micom peripheral circuit is composed of 1Mbyte Flash Memory (ZIC3) for Microcode and data save, 2Kbit EE-PROM (ZIC5) for permanent storage of data needed at power off, 64Mbit SDRAM (ZIC2) for temporary data read and write.

The Micom (ZIC1 ; Vaddis 7) mounted in main board analyzes the key commands of front panel or instructions of remote control and controls the devices on board to execute the corresponding commands after initializing the devices connected with micom on board at power on.

#### 13-3-2 Block Diagram

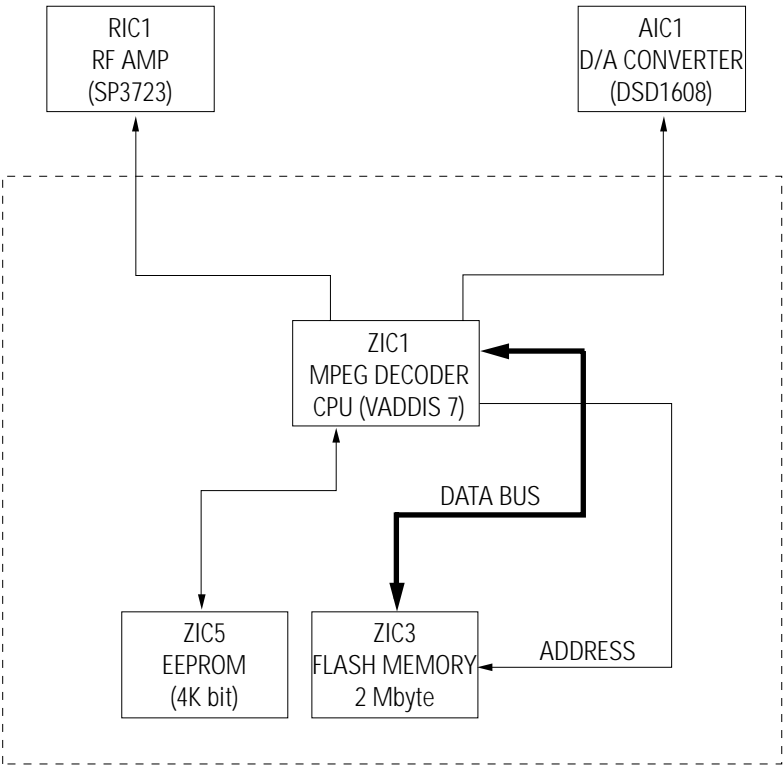

Fig. 13-13

## 13-4 Servo

### 13-4-1 Outline

SERVO system of DVD is Composed of Focusing SERVO, Tracking SERVO, SLED Linked SERVO and CLV SERVO (DISC Motor Control SERVO).

- 1) Focusing SERVO : Focuses the optical spot output from object lens onto the disc surface. Maintains a uniform distance between object lens of Pick-up and disc (for surface vibration of disc).
- 2) Tracking SERVO : Make the object lens follow the disc track in use of tracking error signal (created from Pick-up).
- 3) SLED Linked SERVO : When the tracking actuator inclines outwardly as the object lens follows the track during play, the SLED motor moves slightly (and counteracts the incline).
- 4) CLV SERVO (DISC Motor Control SERVO) : Controls the disc motor to maintain a constant linear velocity (necessary for RF signal).

### 13-4-2 Block Diagram

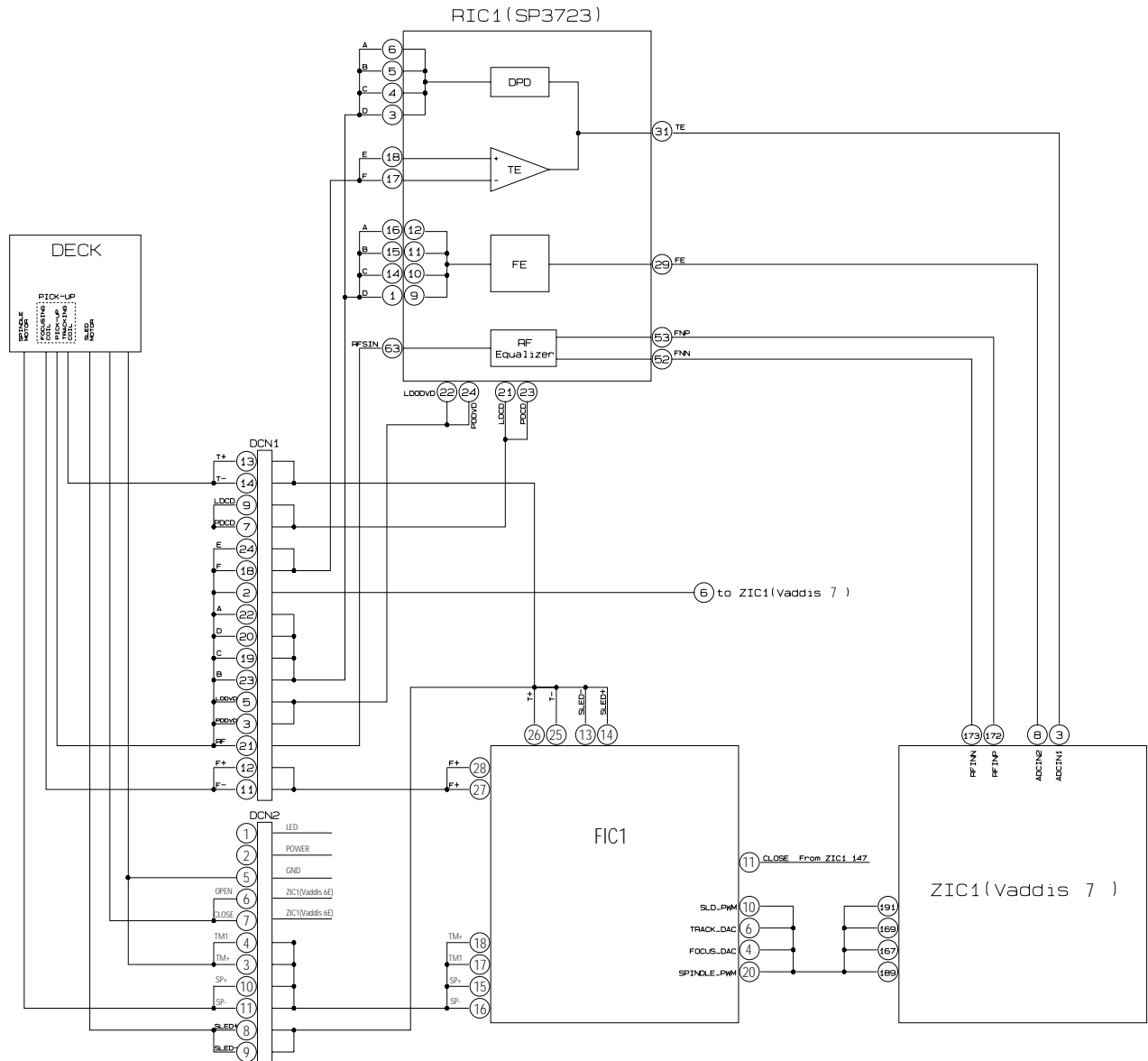

Fig.13-14



### 13-4-3 Operation

#### 1) FOCUSING SERVO

##### (1) FOCUS INPUT

The focus loop is changed from open loop to closed loop, and the triangular waveform moves the object lens up and down (at pin 167 of ZIC1 during Focus SERVO ON.) At that time, S curve is input to pin 181 of ZIC1.

PZ (pin 183 of ZIC1) signal, summing signal of PD A, B, C, D, is generated, and zero cross(1.65V) point occurs when S curve is focused and ABCD signal exceeds a preset, constant value. The focus loop is changed to closed loop, and the object lens follows the disc movement, maintaining a constant distance from the disc. (these operations are same in CD and DVD).

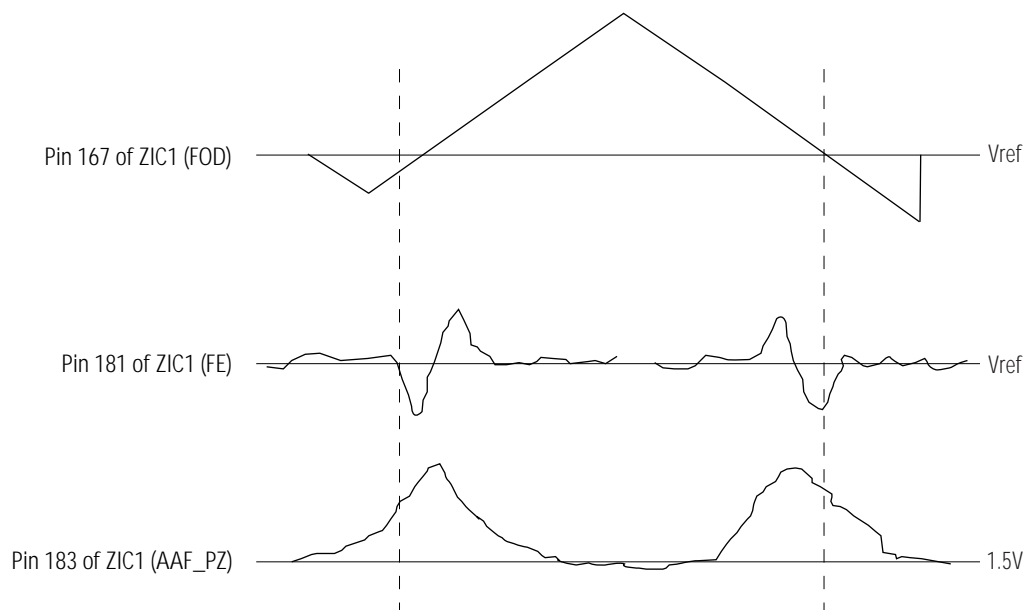

Fig. 13-15

##### (2) PLAY

When focus loop closes the loop during focus servo on, both are controlled by VREF voltage (approx. 1.65V).

#### 2) TRACKING SERVO

##### (1) NORMAL PLAY MODE

###### ① For DVD

Composite : The signal output from PD A, B, C, D of Pick-up, the tracking error signal (pin39 of RIC1) uses the phase difference of A+C and B+D in RIC1, and inputs to ZIC1. Then, it is output to ZIC1 pin 169 via digital equalizer, and applied to the tracking actuator through FIC3.

Pin 69 of ZIC1 is controlled by VREF(approx. 1.65V) during normal play.

Meanwhile, DVD repeats the track jump from 1 to 4 in inner direction at normal play (because data- read speed from disc is faster than data output speed on screen).

###### ② For CD, VCD

Receive the signal output through E, F of Pick-up, from ZIC1. The tracking error signal is similar to DVD.

(2) SEARCH Mode :

Search mode : Fine seek, (Moving the tracking actuator slightly little below 255 track) and coarse search, moving much in use of sled motor. The coarse search will be described in sled linked servo and now, the fine seek is explained shortly.

If the object lens is located near target, cut off the tracking loop and give the control signal as many as desired count to move the tracking actuator via ZIC1 pin 169 terminal (TRD).

3) SLED LINKED SERVO

- Normal play mode

Move SLED motor slightly by means of PWM signal in ZIC1 pin 191, as the tracking actuator moves along with track during play. Control to move the entire Pick-up as the tracking actuator moves.

- Coarse search mode

In case of long-distance search (such as chapter search), ZIC1 uses MIRR and Global sense signal.

Then, read ID and compute the existing track count after input of next track.

If the existing track count is within fine seek range, tracking begins using fine seek.

4) CLV SERVO (DISC MOTOR CONTROL SERVO)

Input RF signal (from Pick-up) to ZIC1 pin 172, 173.

Detect SYNC signal from RF in ZIC1, and output PWM signal to ZIC1 pin 189 for constant linear velocity.

## 13-5 DVD Data Processor

### 13-5-1 Outline

The Vaddis 7 (highly-integrated device) includes the full front-end disc controller, back-end decoder functions as well as the host control CPU.

The principal off-chip components include the disc drive with its optical pickup, tray, sled and spindle drivers and motors, 16Mbits of flash MEMORY, 128Mbits of SDRAM, and the audio Digital-to-Analog converters some applications.

In case of general disc refresh, the memory is almost filled up periodically. It is because Write rate to memory after disc playback and signal process is faster than Read of A/V decoder. When the memory is filled, this status is reported by interrupt to main micom, which controls the servo to kick back the pick-up to the previous track after memorizing the last data read from disc until now. It takes some times to jump to the previous track and return to the original(jump location) again. The memory will have an empty space because A/V decoder reads out data of memory.

When the memory has an empty space, where data can be processed and written and the pick-up correctly gets to the original location(before kick back location) again, it reads data again avoids the interrupt of data read previously. The basic operation repeats to perform as described above.

### 13-5-2 Block Diagram

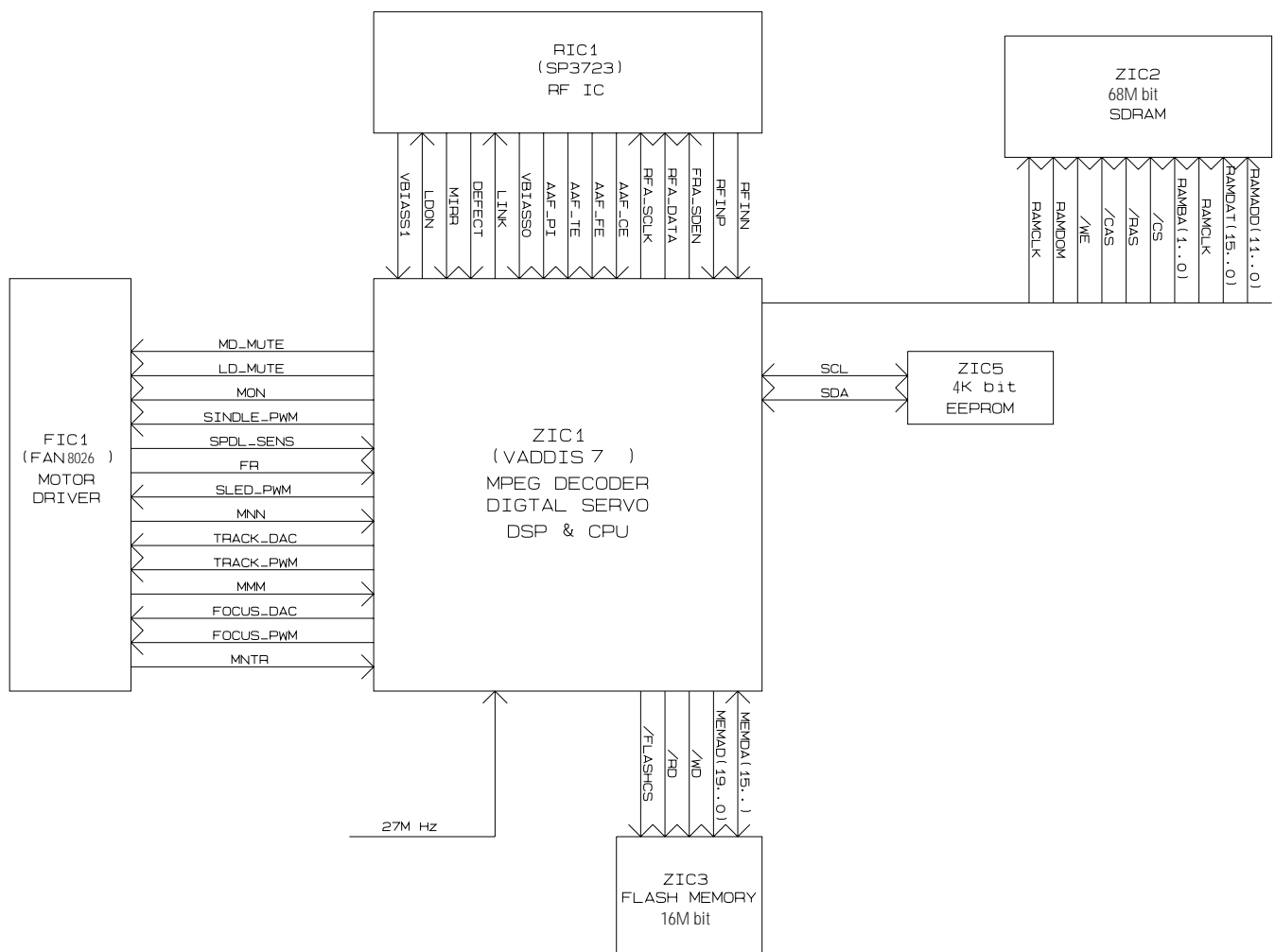

Fig.13-16

## 13-6 Video

### 13-6-1 Outline

ZIC1(A/V decoder with video encoder) diverges from the 27MHz crystal, then generates VSYNC and HSYNC. ZIC1(A/V decoder with video encoder) does RGB encoding, copy guard processing and D/A conversion of 8bit video data internally inputted from video decoder block by ZIC1.

Video signal converted into analog signal is outputted via amplifier of analog part.

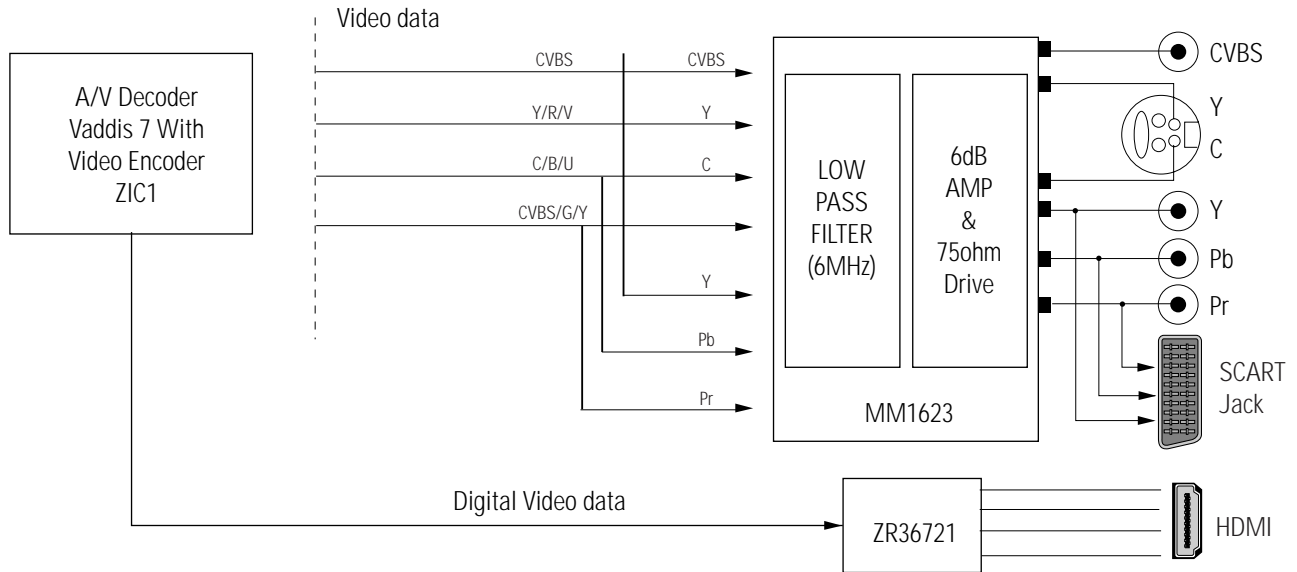

Fig. 13-17 Video Output Block Diagram

### 13-6-2 NTSC/PAL Digital Encoder (VADDIS 7 ; Built in video encode)

ZIC1 inputted from pin 161 with 27MHz generates HSYNC and VSYNC which are based on video signal. ZIC1 is synchronous signals with decoded video signal and control the output timing of 8bit video signal. The separate signal is encoded to NTSC by control of ZIC1.

The above signals, which are CVBS (Composite Video Burst Synchronized)/G (GREEN)/Y, Y (S\_VIDEO)/R (RED)/Pr and C (S\_VIDEO)/B (BLUE)/Pb [PIN162], are selectively outputted CVBS +S\_VIDEO, RGB/Component by the rear switch. In Course of encoding, 8bit data can extend to 10bit or more. To convert the extended data to quantization noise as possible, ZIC1 adopts 10bit D/A converter. ZIC1 perform video en-coding as well as copy protection.

### 13-6-3 Amplifier (VIC1: LA73054)

VIC1 is 6dB amplifier.

Based on CVBS signal, the final output level must be 2Vpp without 75ohm terminal resistance.

Because the level of video encoder output is only 1.1Vpp, the level is adjusted with the special amplifier.

When mute of pin 5 is high active, if the pin is floating and connecte to power, the output signal is never ouputted.

CVBS, Y, C, R, Pb(B), Pr(R) outputted from video encoder are inputted to VIC1 (Pin 2, 8, 6, 16, 14).

The signal to which gain is adjusted by amplifier is outputted from jack via 75ohm Resistance (VR11~VR16).

## 13-7 Audio

### 13-7-1 Outline

A/V decoder (ZIC1 ; Vaddis 7) is supply to DATA 0 for 2-channel mixed audio output.

The audio data transmitted from A/V decoder (ZIC1 ; Vaddis 7) are converted into analog signal via audio D/A converter and outputted via post filter and amplifier.

CD and VCD are outputted with only 2 channels audio data and transmit them to Data 0.

If DVD of multichannel Source disc, if is downmixed and transmit them to Data0.

If you want to listen to the multichannel output, you have to connect digital output with AC-3 amp or MPEG/DTS amp.

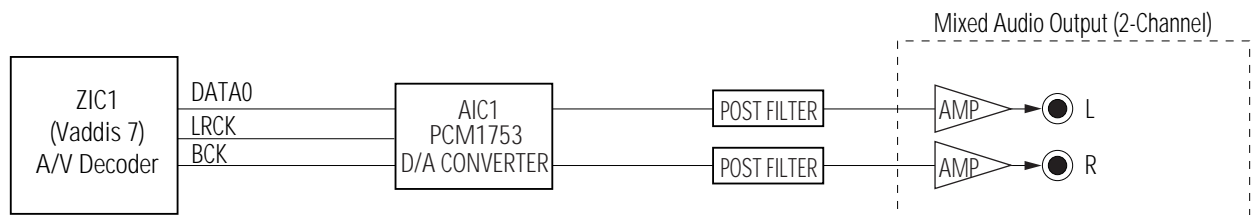

Fig. 13-18 Audio Output Block Diagram

# MEMO

## 14. Reference Information

### 14-1 Introduction to DVD

#### 14-1-1 The Definition of DVD

DVD is the next generation medium and is the acronym of the Digital Versatile Disc or the Digital Video Disc, which maximizes the saving density of the disk surface using the MPEG-2 compression technology to enable the storage of 17G bytes of data on the same size CD.

##### 1) 7 times the storage capacity of the conventional CD

- Minimized the track pitch and pit size to 1/2 of conventional CD.
- Uses red laser with short-wavelength of 650nm (635nm).

##### • DVD Vs. CD-ROM

	CD-ROM	CD-R/RW	DVD-ROM	DVD-R/RW	DVD-RAM
Disc Thickness	1.2mm	1.2mm	0.6*2mm	0.6*2mm	0.6*2mm
Lens NA	0.45	0.45(0.5)	0.6	0.6	0.6
Laser wavelength	780um	780um	650um	650um	650um
Track pitch	1.6pm	1.6pm	0.74pm	0.74pm	0.615pm
Capacity	0.65GB	0.65GB	4.7GB	4.7GB	4.7GB
Track structure	Pit train	Groove	Pit train	Groove	Land/Groove

##### 2) Disc Formats

DVD consists of two 0.6mm discs attached together, enabling access to the upper and lower side of the disk, and 4 sides could be used at maximum.

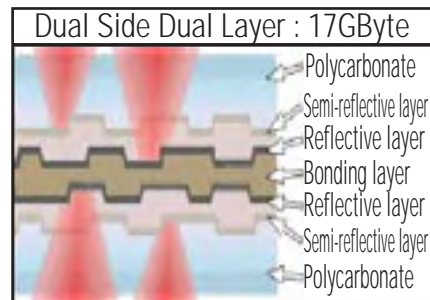
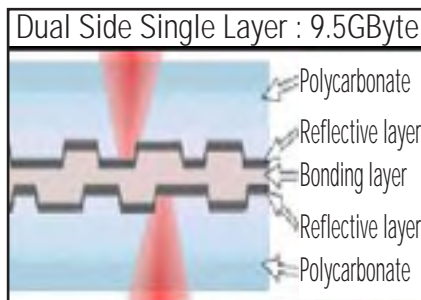
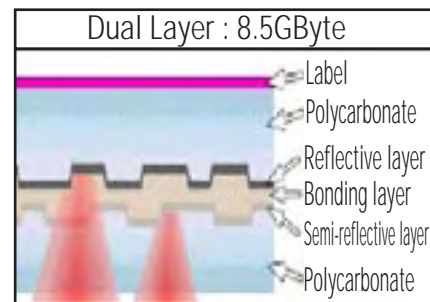
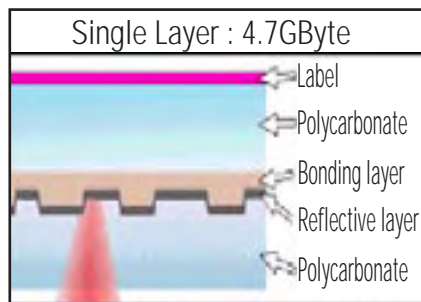

**14-1-2 DVD Types**

<b>FORMAT</b>	<b>TYPE</b>	<b>APPLICATIONS</b>
<b>DVD-Video</b>	Playback Only	High quality image and sound for movies and other video media.
<b>DVD-ROM</b>	Read Only	Multi-functional, multi-media software that requires large storage capacity.
<b>DVD-Audio</b>	Playback Only	High quality sound that exceeds the CD, multi-channel Audio.
<b>DVD-R</b>	1 Time Recording	As with CD-R, write only once
<b>DVD-RAM</b>	Rewritable (more than 100,000times)	This can be virtually used as hard-disk, with a random read-write access
<b>DVD-RW</b>	Rewritable (About 1000times)	Similar to DVD-RAM except than its technology features a separated read-write access more like phonograph than a hard disk.



## 14-2 DVD-Video Fromat

### 14-2-1 Main Features

- 1) Able to store up to 160 minutes of Movie by utilizing the MPEG-2 compression technology. (Aver. 133min.)
- 2) Enables more than 500 lines of horizontal resolution. (Class corresponding to the Master Tapes used in broadcasting stations)
- 3) Provides Dolby Digital 5.1ch Surround 3D sound, which enables theater quality sound (NTSC area).
  - For PAL areas, 1 of either MPEG-2 Audio or Dolby Digital must be selected.
- 4) Multi-Language
  - Able to store up to 8 languages of dubbing.
  - Able to store up to 32 subtitle languages.
- 5) Multi-Aspect Ratio  
3TV Mode alternatives ; 16:9 Wide Screen (DVD Basic)/4:3 Pan & Scan/Letter Box.
- 6) Multi-Story  
Possible to implement Interactive Viewing which enables the user to select the scenario.
- 7) Multi-Angle  
Able to view the camera angle you selected among the scenes recorded with multiple camera angles.

**Note** ; The above media features must have the DVD Title that contains the appropriate contents to function properly.

### 14-2-2 Audio & Video Specifications

Classification		DVD-Video		Video-CD	LD
VIDEO	Compression	MPEG-2		MPEG-1	Analog
	Pixel	720 x 480		352 x 240	
	Horizontal resolution	Max. 500 Lines		Max. 250 Lines	Max.420 Lines
	Compression rate	1/40		1/140	Analog
	Transmission speed	Max. 9.8Mbps (variable)		1.15Mbps (fixed)	
	TV aspect	16:9 / 4:3		4:3	4:3
AUDIO	Audio	Max. 8 streams		2CH stereo	2 Analog CH. 2 Digital CH. (16Bit/44.1KHz)
	Recording type	Dolby Digital	Linear PCM	MPEG-1 Layer 2	
	Transmission rate	448Kbps/stream	6.144Mbps/stream	224Kbps	OR 1 Analog CH. 1 Stream of Dolby Digital 2 Digital CH. (16Bit/44.1KHz)
	Channel	5.1CH/stream	8CH/stream	2CH	
	Sampling frequency	48KHz	16, 20, 24Bit/48, 96KHz	16Bit/44.1KHz	

### 14-2-3 Detailed Feature

#### DVD-Video Feature 1

When Developing the DVD Software, various addition and modification is possible.

As the storage capacity increases, the DVD-Video separates the main data and the additional data such as the Multi-Function into different data areas, enabling the control of time-data ratio to provide the format that enables the flexible Software development

- 1 Movie (3.5Mbps)
  - + Subtitle (1 Language)
  - + Surround Audio (1 Language)
  - = 160min storage (4.673Gbytes)
  
- 1 Movie (3.5Mbps)
  - + Subtitle (4 Language)
  - + Surround Audio (4 Language)
  - = 160min storage (4.680Gbytes)
  
- 1 Music Video (4Mbps)
  - + 2ch High quality Audio (96kHz/24bit)
  - = 72min storage (4.648Gbytes)

#### DVD-Video Feature 2

Application of the MPEG-2 compression technology.

DVD-Video uses the variable compression technology, the MPEG-2 to compress the moving image optimally, minimizing the Data loss to Provide a clear, natural screen while increasing the storage time.

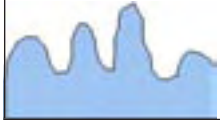
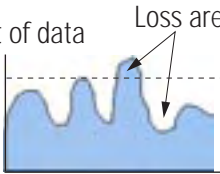
<b>DVD-Video</b>	<ul style="list-style-type: none"> <li>• MPEG-2 (Variable compression : Max. 1/40)                             <ul style="list-style-type: none"> <li>• Field unit compression.</li> <li>• Compression rate change according to the amount of Data.</li> <li>• Differentiates the still image and the moving image compression rate, reducing Data loss and enables efficient compression.</li> </ul> </li> </ul>	<p style="text-align: center;">Amount of data</p>  <p style="text-align: right;">Time</p>
<b>Video-CD</b>	<ul style="list-style-type: none"> <li>• MPEG-1 (Fixed compression : Max. 1/140)                             <ul style="list-style-type: none"> <li>• Frame unit compression.</li> <li>• Compresses all data using the same ratio.</li> </ul> </li> <li>- Fast movements are jagged, and unnatural</li> </ul>	<p style="text-align: center;">Amount of data</p>  <p style="text-align: right;">Time</p>

**DVD-Video Feature 3****High quality surround audio.**

DVD-Video can store the audio using the 5.1ch Dolby Digital compression or the advanced Linear PCM method, providing the better-than-CD quality and theater like audio quality.

- **DTS (Digital Theater System)**

Home theatre and music playback in the home, DTS provides high quality 5.1-channel surround sound with many extras not offered by other consumer formats. As well as handling DTS-branded releases from a growing number of music labels and consumer software producers, DTS provides enhanced 6.1 matrix and DTS 6.1 discrete decoding that envelopes the listener in sound. DTS technology is featured in a wide cross section of receiver/pre-amplifiers, DVD players and add-on components from leading consumer audio vendors

- **Dolby Digital (AC-3)**

- Unlike the traditional Dolby pro-Logic method, the Dolby Digital method separates all 5 main channels (Front L/R, Center, Surround (Rear) L/R) and the Sub woofer to provide live surround audio.
- Using the Down Mix method, the conventional Dolby Pro-Logic and Stereo are all compatible.
- Each separated channels are played back at CD quality sound. (Frequency band: 20Hz ~ 20KHz)

- **Linear PCM (Pulse Code Modulation)**

- Provides the high quality Digital sound without the audio data compression.
- Various Digital Recordings are possible as shown in the table to the right.

Sampling Frequency	Bit Rate
48KHz	16bit
	20bit
	24bit
96KHz	16bit
	20bit
	24bit

- **Dolby Digital compatible Audio Mode**

Audio Coding Mode	Channel Format					Remark
		Front		Surround (Rear)		
	L	C	R	L	R	
1/0		0				Mono
2/0	0		0			Stereo
3/0	0	0	0			Surround
2/1	0		0	Mono		
3/1	0	0	0	Mono		
2/2	0		0	0	0	
3/2	0	0	0	0	0	

**DVD-Video Feature 4**

**Multi-Language**

- Audio Dubbing - Max. 8 Languages
- Subtitle - Max. 32 Languages. Capable of storing, and selecting.
- Linear PCM (Pulse Code Modulation)

**DVD-Video Feature 5**

**Multi-Aspect**

- Unlike the conventional VCD or LD, DVD-Video has the default of 16:9 Wide, and can be viewed using the conventional 4:3 TV, enabling the expansion of viewer selection capabilities.
- 16 : 9 TV : Wide Mode (16:9 Wide Full Screen)
- 4 : 3 TV : Letter Box Mode, Pan & Scan Mode

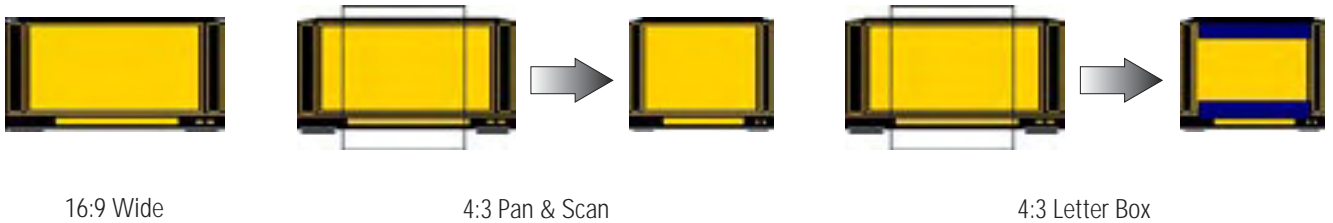

**Note ;** This function is disc-dependent, may not work on all DVDs.

**DVD-Video Feature 6**

**Multi-Angle**

- Up to 9 angles of view may be stored, enabling the viewer to select a specific viewpoint at a given time.  
--> Especially, for the Music Video and Sports Title, this provides a more lively image of the scene.

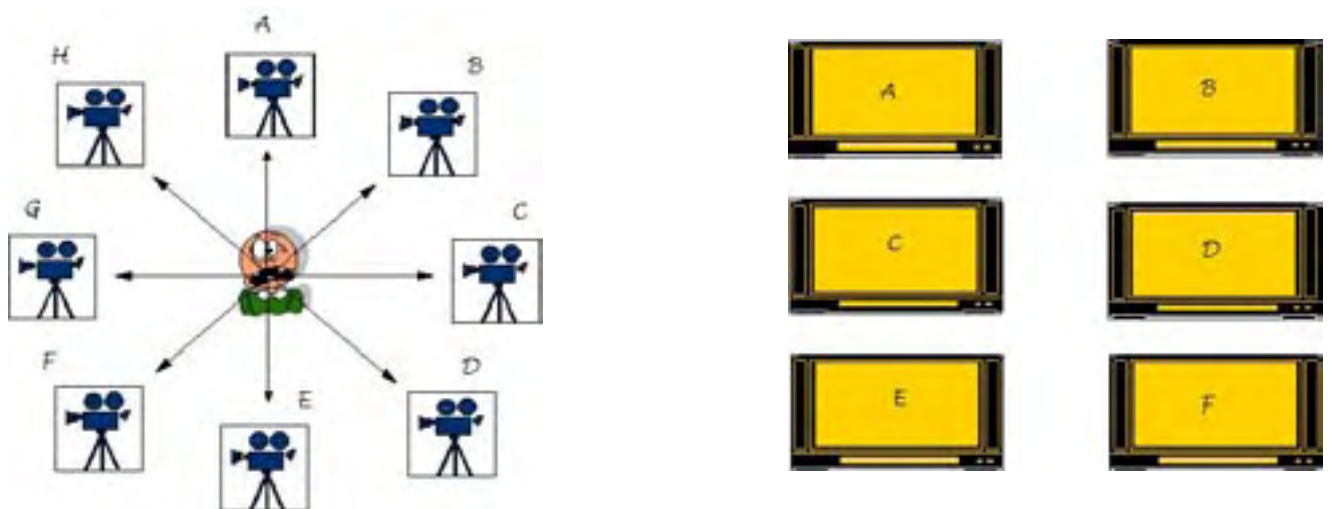

**Note ;** This function is disc-dependent, may not work on all DVDs.

## DVD-Video Feature 7

## Multi-Story

- DVD-Video provides the environment suitable for the bi-directional Software development, providing multiple scenarios. This feature enables the Multi-Story function.

## OPTION

## Parental Lock

- For the titles that are not suitable for children viewing, Parental Locks are set, requesting user defined passwords for viewing
- Parental Locks may be set on specific frames of the Title, enabling the player to skip those frames during playback.

## COPYRIGHT

## Regional Code &amp; Macrovision

- Classify the world into 6 regions, and if the DVD Title and the Player's "Regional Code" do not agree, playback is prohibited.
- **Regionnal Coding is optional for the Soft developers (Region 0 All Code), but the Hardware developers must adopt the appropriate regional code for sale.**
  - Region 1 : The United States and its territories, Canada.
  - Region 2 : Europe, Japan, Greenland, Egypt, South Africa, the Middle East.
  - Region 3 : Taiwan, Hongkong, Korea, South East Asia.
  - Region 4 : Mexico, South America, Australia, New Zealand.
  - Region 5 : Russia, Eastern Europe, India, Africa.
  - Region 6 : China.
  - Region 0 : Worldwide (All Code)

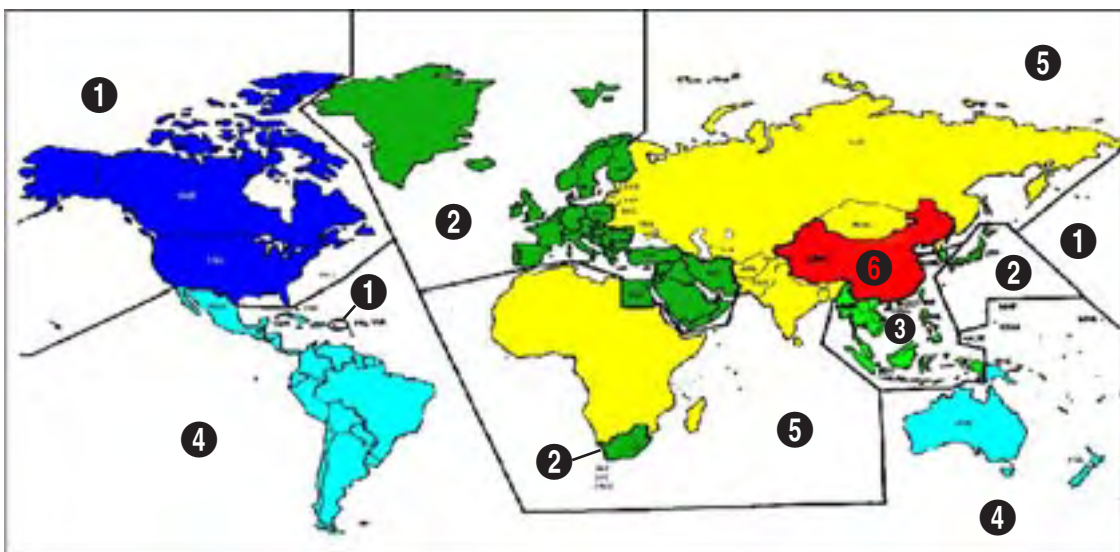

- Adoption of the Macrovision System disables the copying on to other media.

<b>Remark</b>	<b>DVD-Video Authoring Process</b>
---------------	------------------------------------

- The image quality of the DVD-Video may vary according to the quality of the Master and the Authoring Process
  - The image quality of the DVD-Video varies according to the Digital Mastering Source such as the conventional LD, VCD, or Original Film.
  - Different Authoring Process are used according to the Software developers, and this may affect the DVD image quality.

• **Authoring Process**

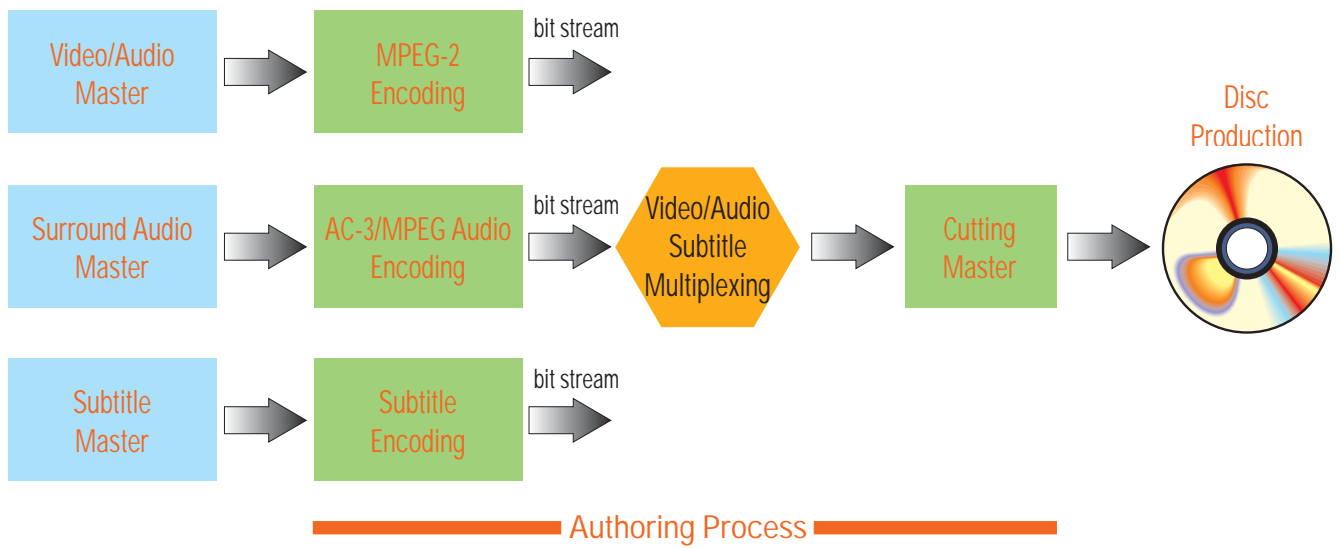

## 14-3 DVD-Audio

## The Logical Structure of DVD-AUDIO

- Album
  - Each side of a DVD-Audio disc contains one
- Group
  - Essentially a playlist specifying the playback order of a number of Tracks
  - 9 per Album
- Track
  - As on a CD, a Track may be thought of as a single audio program (I.e. a song)
  - Audio attributes such as channel assignment, sample rate, and word-length may be changed on Track boundaries
  - There may be no more than 99 tracks total within a single Group
- Index
  - A reference point to a portion of an audio Track (Cell)
  - There may be up to 99 indices within a single Track

### Audio Still Video

- Still pictures playback with audio.

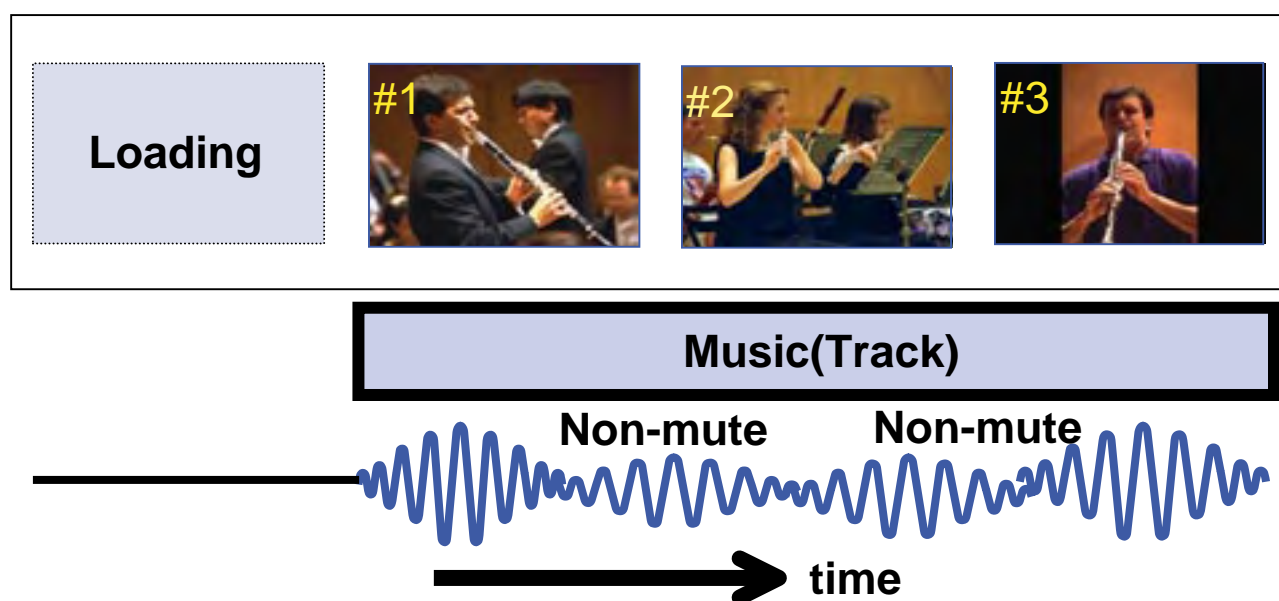

## Real Time Text

-Supports Text data with audio

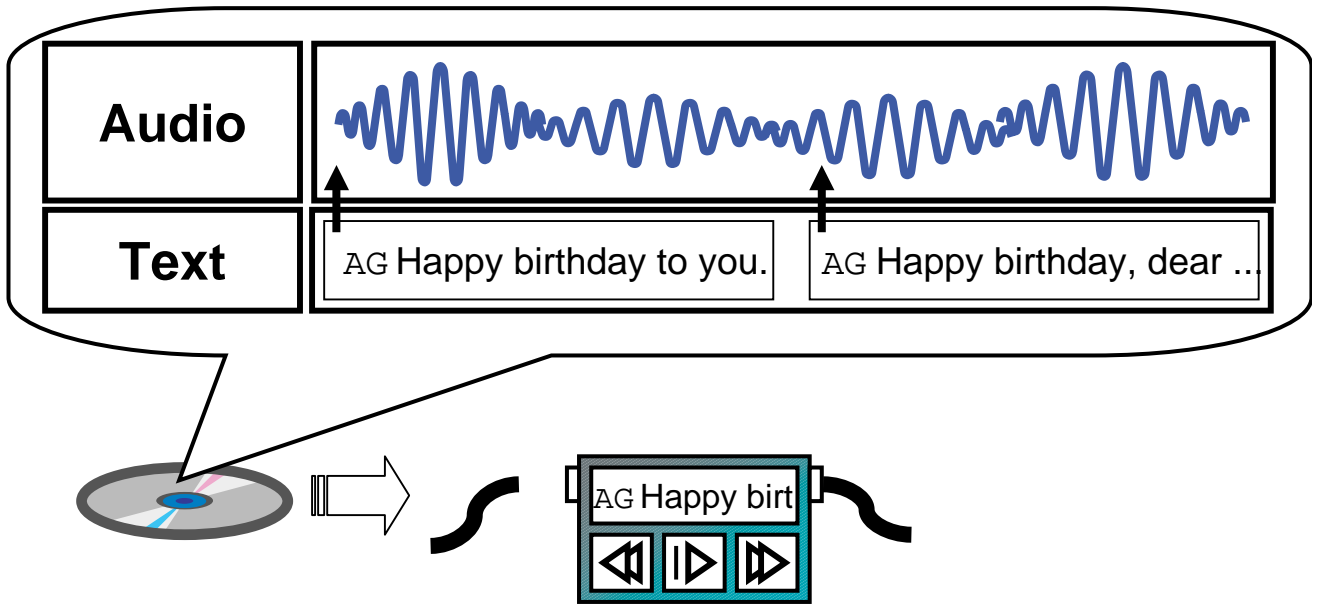

## DVD-VIDEO Data in DVD-AUDIO Disc.

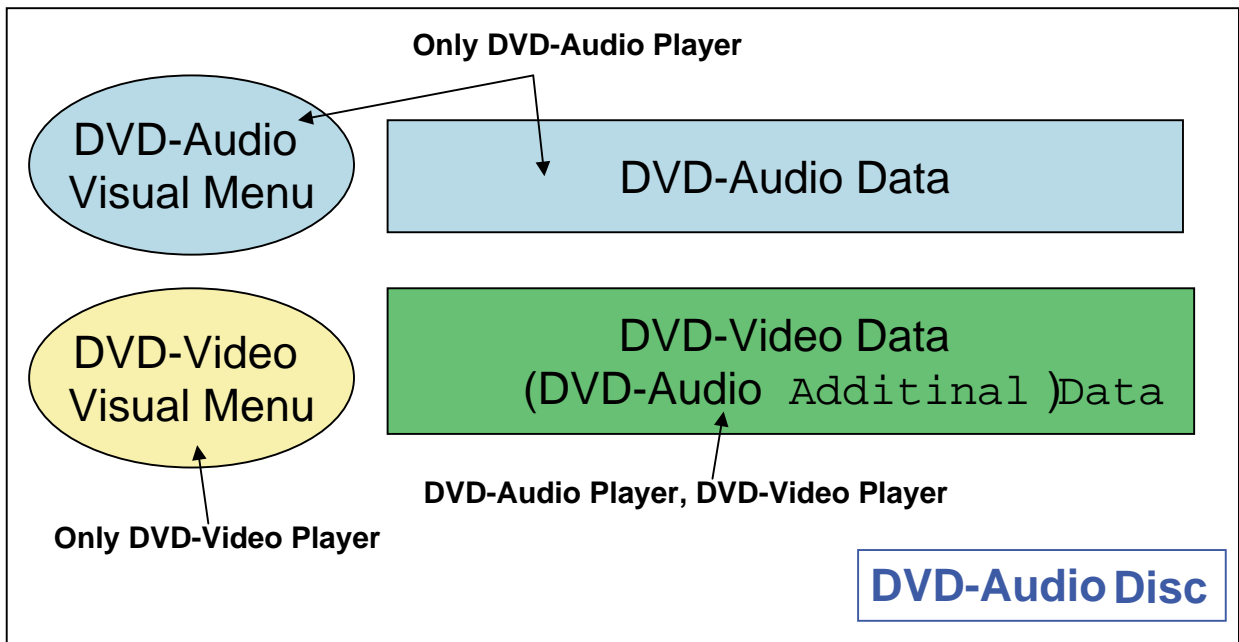



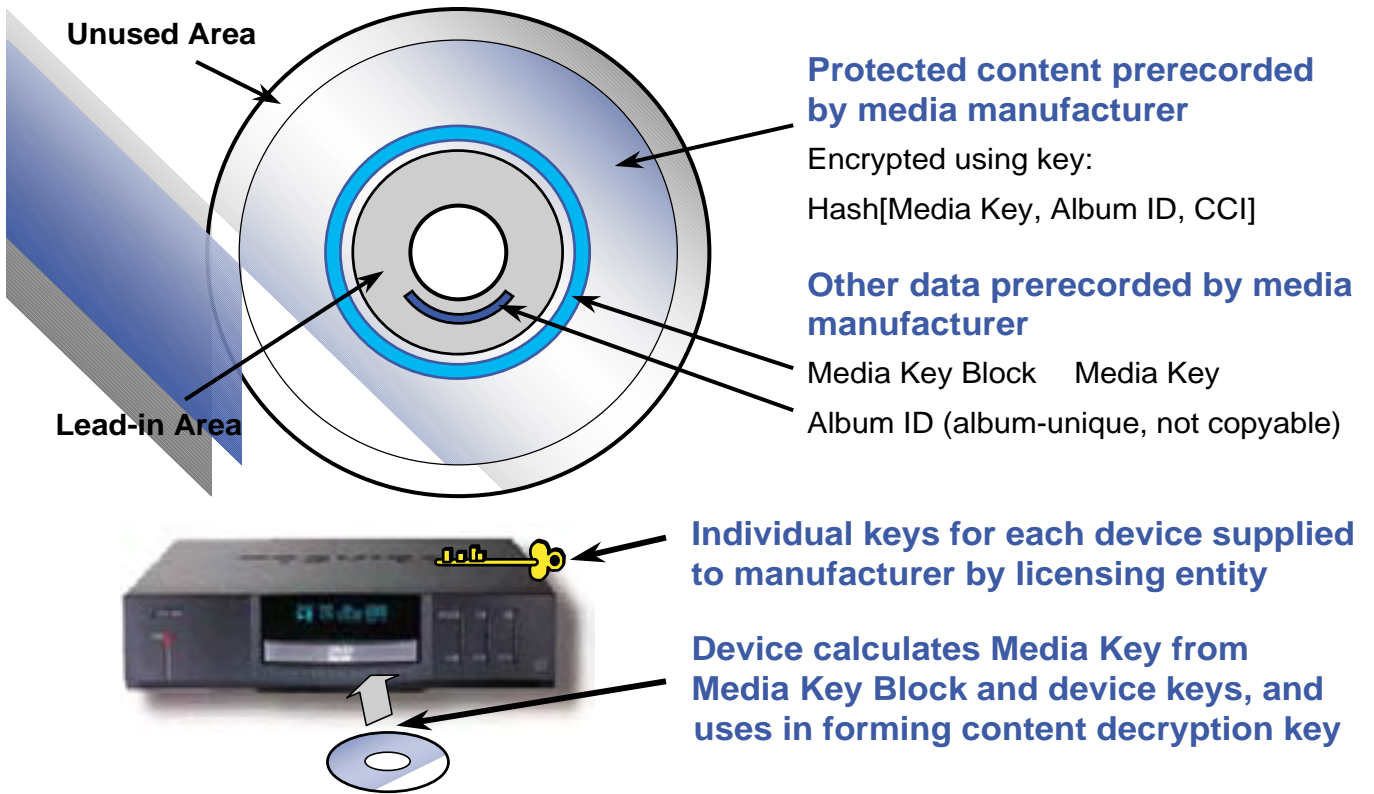

**DVD-VIDEO Data in DVD-AUDIO Disc.**

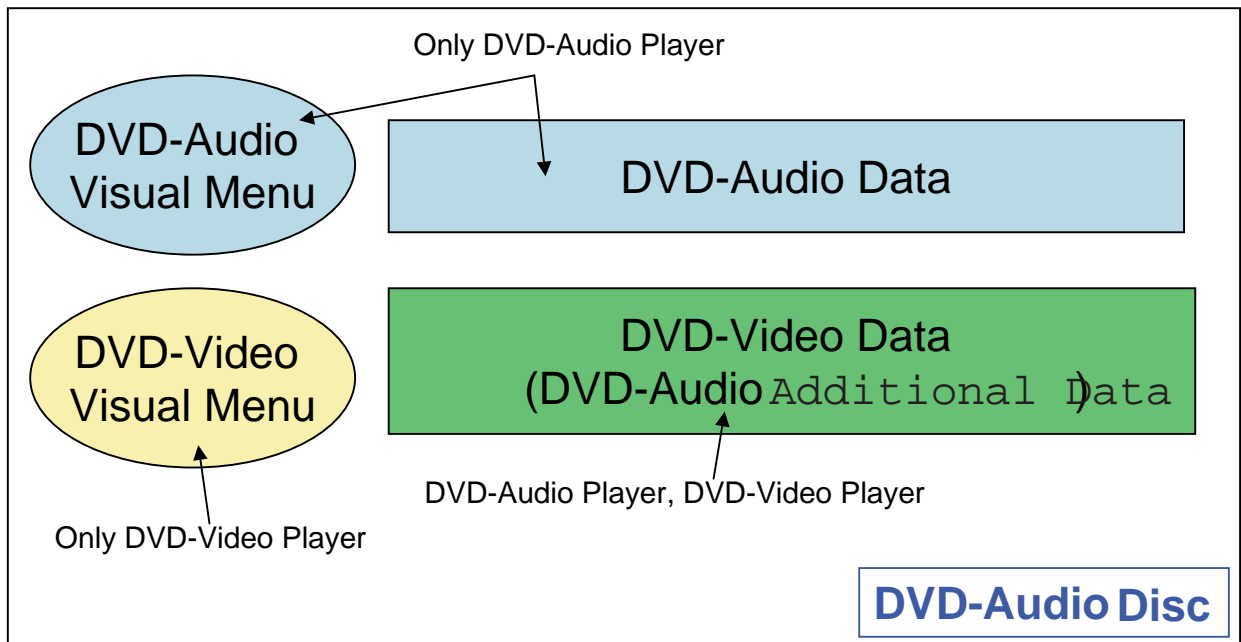

## 14-4 DivX

---

- **DivX: Most successful MPEG-4 video compression technology in history.**
  - standard for digital video ('MP3 of Video').
  - Internet's 3<sup>rd</sup> most downloaded application,
  - MPEG-4 video codec.
  - Secure, MPEG-4, DVD-quality VOD products.
- **Powerful technology...**
  - DVD quality: ~784Kbps.
  - NTSC/PAL: <500Kbps.
  - 720P HD: <4Mbps.
  - 1080p HD: <7Mbps.
  - 32Kbps to Digital Cinema.
  - 80+ hours of portable video.
- **There are many different MPEG-4 profiles.**
  - 'Simple Profile' (SP) is the most basic; other profiles are SP plus other tools.
- **Advanced Simple Profile (ASP) is emerging as the standard for consumer and CE applications.**

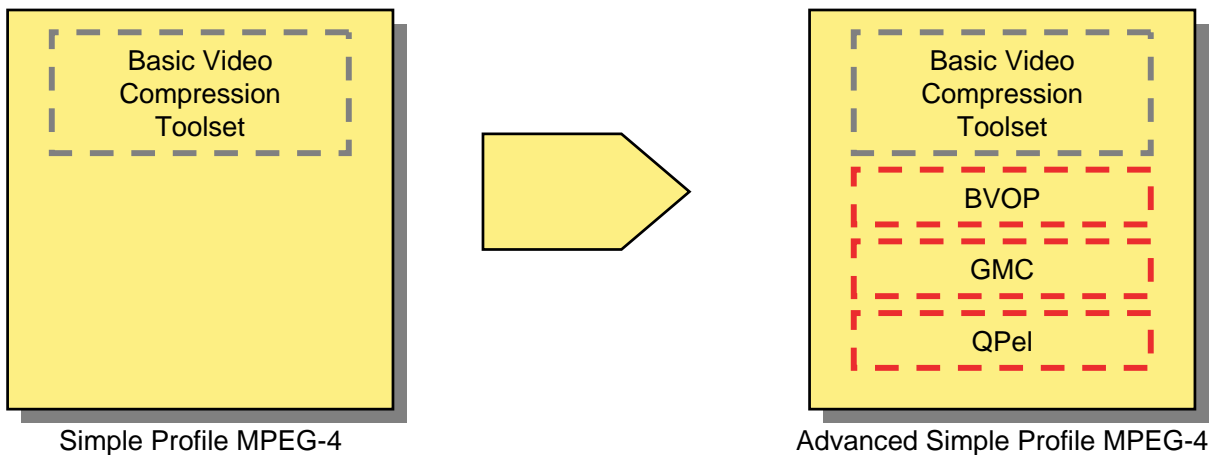

- **DivX 3.11 is a legacy technology that is not MPEG-4 compatible**
  - Requires different decoding algorithms – cannot be decoded by a generic MP 4 decoder.
  - Constitutes about 45% of the DivX content on the Internet today.
- **Open DivX is a MPEG-4 Simple Profile Implementation.**
  - Released to the Internet community in Jan/2001
- **DivX 4.x is a highly optimized MPEG-4 Simple Profile Implementation.**
  - Released Aug/2001.
- **DivX 5.0 – 5.02 is a MPEG-4 Advanced Simple Profile Implementation.**
  - Released Mar/2002.
- **DivX 5.1 is a MPEG-4 Advanced Simple Profile Implementation stabilized and optimized for CE devices.**
  - Released Nov/2002; GMC and QPel support are not required for certification.
- **DivX 5.2.1 is the latest version until now**
  
- **DivX remains MPEG-4 compatible:**
  - A generic MPEG-4 Simple Profile decoder can decode Open DivX and DivX 4.x content
  - A generic MPEG-4 Advanced Simple profile decoder can decode content encoded with Open DivX, DivX 4.x and DivX 5.x.

• DivX 5.X decoder advantages:

- Fully MPEG-4 ASP compliant (superior to all Simple Profile decoders).
- DivX 3.11 decoder (critical for existing DivX content on the Internet).
- DivX proprietary post-processing (improves all files).
- DivX advanced tools (interlace, PVM, telecine, etc).
- DivX DRM
- And the standard DivX advantages of users, content, and brand).

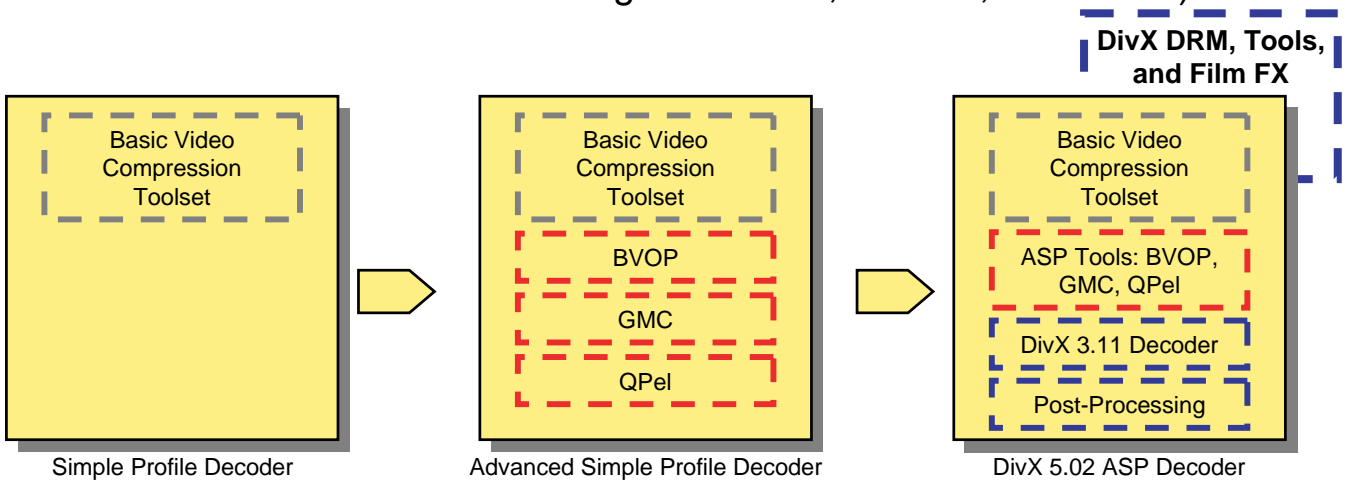



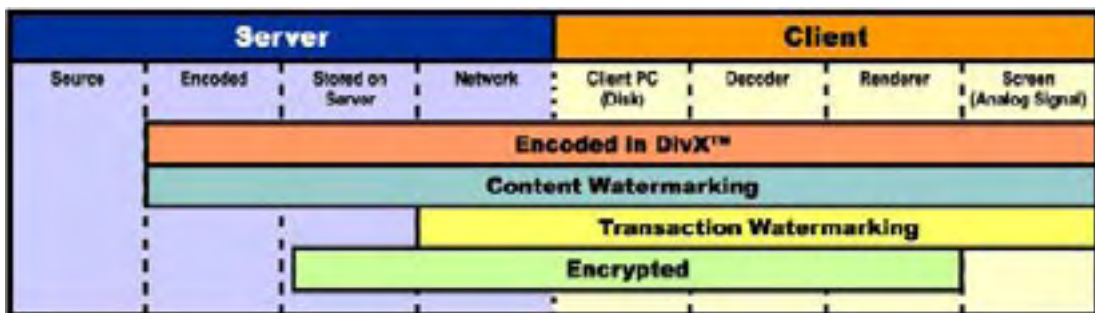

• **All Versions of DivX require DivX DRM to be implemented in IC.**

- DivX content is protected in numerous ways to ensure security.
  - Content never exists in an unencrypted form.
- The DivX DRM system quickly identifies and responds to security attacks.
- Content owners have maximum flexibility to set usage rules and to enforce Digital Millennium Copyright Act (DMCA) rights.
- **All DivX Certified CE devices require DivX DRM.**



- |  |   |
|--|---|
| <ul style="list-style-type: none"> <li>• Pre-Encryption</li> <li>• Key Rotation</li> <li>• Encryption Rotation</li> <li>• Static Watermarking</li> </ul> | <ul style="list-style-type: none"> <li>• Dynamic Watermarking</li> <li>• Central Business Rule(s)</li> <li>• Server Key Management</li> <li>• Secure Channels</li> <li>• Tamper Resistance</li> </ul> |
|--|---|

DivX Certification helps CE makers get high-quality devices to market.

<b>PLATFORM</b>				
<b>Screen Size Requirements</b>	<b>3" X 3" Max</b> (76.2 x 76.2 mm)	<b>3" X 3" - 12" X 9"</b> (76.2 x 76.2 - 304.8 x 228.6 mm)	<b>12" X 9" or larger</b> (304.8 x 228.6 mm)	<b>Any HD Screen Size</b>
<b>Resolution and Frame Rate</b>	176 X 144 @ 15 fps	352 X 240 @ 30 fps 352 X 288 @ 25 fps	720 X 480 @ 30 fps 720 X 576 @ 25 fps	1280 X 720 @ 30 fps
<b>Video Type</b>	Progressive	Progressive	Progressive and Interlaced	Progressive and Interlaced
<b>DivX Versions</b>	DivX 3.11, 4.x, 5.x	DivX 3.11, 4.x, 5.x	DivX 3.11, 4.x, 5.x	DivX 3.11, 4.x, 5.x
<b>DivX DRM</b>	Yes	Yes	Yes	Yes
<b>Post-Processing</b>	None	Deblocking on Luma	Deblocking, Deringing, Film FX	Deblocking, Deringing, Film FX