

SANDERS PROPRIETARY

**PCS-OVER-CABLE CMI/HIC SYSTEM
VERSION 1.85**

**OPERATION AND MAINTENANCE MANUAL
FOR
HEADEND EQUIPMENT AND CABLE
MICROCELL INTEGRATOR**

Document No. 8337148

SEPTEMBER 1997

Revision -



THIS DOCUMENT CONTAINS PROPRIETARY INFORMATION OF SANDERS, A LOCKHEED MARTIN COMPANY, AND IS TO BE USED ONLY FOR THE PURPOSE FOR WHICH IT HAS BEEN SUPPLIED. THIS DOCUMENT IS NOT TO BE DUPLICATED IN WHOLE OR IN PART WITHOUT PRIOR WRITTEN PERMISSION FROM A DULY AUTHORIZED REPRESENTATIVE OF SANDERS.

THE REVISION STATUS OF ALL PAGES IN THIS DOCUMENT IS THE SAME AS THAT STATED ON THIS COVER.

UNRELEASED DRAFT - TRAINING USE ONLY

Copyright © 1997 Lockheed Martin Corporation
Sanders, A Lockheed Martin Company
All rights reserved.

SANDERS PROPRIETARY

SANDERS PROPRIETARY

**PCS-OVER-CABLE CMI/HIC SYSTEM
VERSION 1.85**

**OPERATION AND MAINTENANCE MANUAL
FOR
HEADEND EQUIPMENT AND CABLE
MICROCELL INTEGRATOR**

SEPTEMBER 1997



REVIEW AND CONCURRENCE

SYSTEM ENGINEER

DATE

SYSTEM ENGINEERING MANAGER

DATE

PROGRAM MANAGER

DATE

THIS DOCUMENT CONTAINS PROPRIETARY INFORMATION OF SANDERS, A LOCKHEED MARTIN COMPANY, AND IS TO BE USED ONLY FOR THE PURPOSE FOR WHICH IT HAS BEEN SUPPLIED. THIS DOCUMENT IS NOT TO BE DUPLICATED IN WHOLE OR IN PART WITHOUT PRIOR WRITTEN PERMISSION FROM A DULY AUTHORIZED REPRESENTATIVE OF SANDERS.

Document No. 8337148
Revision -

SANDERS PROPRIETARY

SANDERS PROPRIETARY

**DOCUMENT NO. 8337148
DOCUMENT CHANGE HISTORY**

DATE	REV	DESCRIPTION	APPD
9/30/97	-	Approved for engineering and training use.	MRB

SANDERS PROPRIETARY

TABLE OF CONTENTS

SECTION 1. INTRODUCTION..... 1-1

1.1 SCOPE..... 1-1

1.2 ABOUT THIS MANUAL..... 1-1

 1.2.1 Notation Conventions..... 1-1

 1.2.2 Manual Organization..... 1-2

1.3 SYSTEM OVERVIEW 1-2

 1.3.1 Headend Equipment Primary/Expansion Rack Assemblies 1-3

 1.3.1.1 Headend Control Unit (HECU)..... 1-3

 1.3.1.2 15 MHz Distribution Assembly 1-5

 1.3.1.3 Headend Interface Converter (HIC) 1-5

 1.3.1.4 Cable Assemblies 1-5

 1.3.1.5 +24V Power Supply Assembly 1-6

 1.3.2 Cable Microcell Integrator (CMI)..... 1-6

 1.3.2.1 Power Extractor Module 1-7

 1.3.2.2 Transceiver Module..... 1-7

 1.3.2.3 Power Supply Module 1-7

 1.3.2.4 Power Amplifier Module 1-8

1.4 SYSTEM STARTUP 1-8

1.5 REMOTE OPERATION 1-8

1.6 MENUS AND DIALOGS..... 1-8

1.7 REFERENCE DOCUMENTATION 1-8

1.8 ACRONYMS AND ABBREVIATIONS 1-9

SECTION 2. CONTROLS AND INDICATORS..... 2-1

2.1 HEADEND PRIMARY/ EXPANSION RACK CONFIGURATIONS 2-1

 2.1.1 Front and Rear Panels 2-1

 2.1.2 Optional Power Supply Configuration..... 2-2

 2.1.3 Headend Control Unit (HECU) Front Panels..... 2-3

 2.1.4 Headend Interface Converter (HIC) Front and Rear Panels..... 2-4

 2.1.4.1 HIC Front Panel..... 2-4

 2.1.4.2 HIC Rear Panel..... 2-5

 2.1.5 CMI 2-8

2.2 PCS-OVER-CABLE CMI/HIC SYSTEM OPERATING INSTRUCTIONS 2-8

 2.2.1 Operating Menus 2-8

 2.2.2 Operating Procedures..... 2-8

 2.2.3 Maintenance Instructions..... 2-8

SECTION 3. OPERATING MENUS AND DIALOGS 3-1

3.1 OPERATING SOFTWARE USER INTERFACE..... 3-1

3.2 INITIALIZATION 3-2

 3.2.1 CONFIGURATION OPTIONS Dialog..... 3-2

 3.2.2 Open Dialog 3-4

 3.2.3 INITIALIZATION OPTIONS Dialog 3-4

3.3 HEADEND CONTROL PANEL MENUS AND DIALOGS 3-5

 3.3.1 HEADEND CONTROL PANEL Dialog..... 3-5

 3.3.2 ADD HIC Dialog..... 3-7

 3.3.3 Delete Control (HIC)..... 3-9

3.3.4	Headend Control Panel Menu Commands.....	3-10
3.3.5	Privileges Menu Commands.....	3-11
3.3.5.1	Increase Privileges.....	3-11
3.3.5.2	Decrease Privileges.....	3-11
3.3.5.3	Change Password.....	3-11
3.3.5.4	Logout of HECU.....	3-12
3.3.5.5	Modify Privileges.....	3-13
3.3.6	Configuration Menu Commands.....	3-14
3.3.7	Communications Menu Commands.....	3-15
3.3.7.1	Hardware Link.....	3-15
3.3.7.2	NOCC Link.....	3-15
3.3.7.3	Remove ID From Database.....	3-15
3.3.7.4	View Command Log.....	3-16
3.3.7.5	Set Comm Params.....	3-16
3.3.7.6	Purge Message Queue.....	3-17
3.3.8	Alarms Menu Commands.....	3-17
3.3.8.1	Unacknowledged Alarms.....	3-18
3.3.8.2	Open Alarms.....	3-19
3.3.8.3	View Alarm Log.....	3-19
3.3.8.4	CMI Out of Service Alarms.....	3-20
3.3.9	Polling Menu Commands.....	3-21
3.3.9.1	Set Polling Interval.....	3-21
3.3.9.2	Status Polling Interval.....	3-21
3.3.10	Display Menu Commands.....	3-21
3.3.10.1	Show/Hide Expansion Rack.....	3-22
3.3.10.2	Show/Hide Toolbar on Startup.....	3-22
3.3.11	Help Menu Commands.....	3-22
3.3.11.1	HECU Device Color Codes.....	3-22
3.3.11.2	About HECU.....	3-23
3.3.12	Shutting Down the HECU Software Program.....	3-24
3.4	HIC DIALOGS.....	3-25
3.4.1	HIC CONTROL PANEL Dialog.....	3-25
3.4.2	ADD CMI Dialog.....	3-27
3.4.3	HIC Upstream Power Control.....	3-29
3.4.4	HIC Upstream Frequency Control.....	3-30
3.4.5	HIC PCS Frequency Control.....	3-31
3.4.6	HIC Administrative Data.....	3-32
3.4.7	HIC Communications Statistics.....	3-33
3.4.8	HIC PLL Status Display.....	3-34
3.4.9	HIC Downstream Power Control.....	3-35
3.4.10	HIC Downstream Channel Control.....	3-36
3.4.11	HIC Reference and Control Tones.....	3-37
3.4.12	Code Download Control.....	3-37
3.4.13	HIC Reset Control.....	3-38
3.4.14	Reassign CMI.....	3-39
3.4.15	Delete Control (CMI).....	3-39
3.4.16	HIC Alarms Enable/Disable.....	3-40
3.4.17	CMI Group Control.....	3-41
3.5	CMI DIALOGS.....	3-42

3.5.1 CMI CONTROL PANEL dialog	3-42
3.5.2 CMI Upstream Power Control	3-44
3.5.3 CMI Downstream Power Control	3-45
3.5.4 Transceiver Control Panel	3-46
3.5.5 CMI Administrative Data	3-47
3.5.6 CMI Communications Statistics	3-48
3.5.7 CMI PLL Status Display	3-49
3.5.8 CMI Reset Control	3-49
3.5.9 CMI Alarms Enable/Disable	3-50
3.5.10 PING CMI.....	3-51
3.5.11 US SETPOINT INITIALIZATION.....	3-52
SECTION 4. OPERATING PROCEDURES.....	4-1
4.1 HEADEND EQUIPMENT TURN-ON/TURN-OFF	4-1
4.1.1 Energizing Primary/Expansion Rack	4-1
4.1.1.1 115 Vac Power Source Turn-on Procedure	4-1
4.1.1.2 +24V Power Source Turn-on Procedure.....	4-1
4.1.2 Deenergizing Primary/Expansion Rack	4-1
4.1.2.1 +24V Power Source Turn-off Procedure	4-1
4.1.2.2 115 Vac Power Source Turn-off Procedure.....	4-1
4.1.3 Headend Control Unit (HECU) Turn-on/Turn-off Procedure	4-1
4.1.4 Headend Interface Converter (HIC) Turn-on/Turn-Off Procedure.....	4-2
4.2 HECU SOFTWARE PROCEDURES.....	4-2
4.2.1 Initializing the HECU Software Program	4-2
4.2.2 Logging In	4-3
4.2.2.1 Increasing Privileges.....	4-3
4.2.2.2 Changing Passwords	4-3
4.2.2.3 Modifying Privileges	4-3
4.2.3 Logging Out and Back In	4-4
4.2.3.1 Logging Out.....	4-4
4.2.3.2 Logging Back On	4-4
4.2.4 Shutting Down the HECU Software Program	4-4
4.3 ASSIGNMENT, CONTROL AND MONITORING OF HICs AND CMIs.....	4-4
4.3.1 HIC Assignment, Control and Monitoring.....	4-5
4.3.1.1 Add HIC to Rack	4-5
4.3.1.2 Change, Review, or Save Active HIC Status.....	4-6
4.3.1.3 Deactivate HIC (Delete HIC).....	4-12
4.3.2 CMI Assignment, Control and Monitoring	4-13
4.3.2.1 Add CMI to HIC	4-13
4.3.2.2 Change or Review CMI Status	4-14
4.3.2.3 Deactivate CMI (Delete CMI)	4-16
4.4 SETTING CMI REVERSE LINK SIGNAL LEVEL SETPOINT	4-16
4.4.1 Determining the Rough Target Level.....	4-16
4.4.2 Upstream Setpoint Initialization.....	4-17
4.4.3 Alternate Balancing Method.....	4-18
4.5 ALARM PROCEDURES	4-19
4.5.1 Enabling/Disabling HIC Alarms	4-19
4.5.2 Enabling/Disabling CMI Alarms.....	4-19
4.5.3 Acknowledging and Closing Alarms	4-20

4.5.3.1 Unacknowledged Alarms	4-20
4.5.3.2 Open Alarms	4-21
4.6 REVIEWING AND UPDATING STATUS	4-21
4.6.1 HIC Status	4-21
4.6.1.1 HIC Updating Control Panel Status	4-21
4.6.1.2 HIC Administrative Status	4-21
4.6.1.3 HIC Communications Statistics	4-21
4.6.1.4 HIC Phase Lock Loop Status	4-21
4.6.2 CMI Status	4-22
4.6.2.1 CMI Updating Control Panel Status	4-22
4.6.2.2 CMI Administrative Status	4-22
4.6.2.3 CMI Communications Status	4-22
4.6.2.4 CMI Phase Lock Loop Status	4-22
4.7 SOFTWARE MAINTENANCE	4-22
4.7.1 HECU Database File Backup and Restore Procedures	4-22
4.7.1.1 Saving the Configuration	4-23
4.7.1.2 Making the Backup Copy	4-23
4.7.1.3 Restoring From the Backup Copy	4-23
4.7.2 Software Download Procedures	4-24
4.7.2.1 Remote CMI Download Via HECU	4-24
4.7.2.2 On-Site CMI Download using RS-232	4-27
4.7.2.3 CMI Download Troubleshooting	4-31
4.7.2.4 RS-232 Download Cable Requirements	4-32
4.7.2.5 HIC Software Download from the HECU	4-33
4.7.2.6 HECU Software Download	4-35
4.7.3 HECU Software System Verification	4-36
4.8 RESET	4-37
4.8.1 HIC Reset	4-37
4.8.2 CMI Reset	4-38
SECTION 5. MAINTENANCE AND TROUBLESHOOTING	5-1
5.1 SCHEDULED MAINTENANCE	5-1
5.1.1 HECU Computer Dust Filter	5-1
5.1.2 HIC Dust Filter	5-1
5.1.3 HIC BTS/CATV Connectors	5-2
5.2 INSTALLATION OF OPTIONAL INTERNAL POWER SUPPLY	5-2
5.2.1 Rack Modification for +24V Power Supply Installation	5-2
5.2.2 +24V Power Supply Installation (8303743G1)	5-3
5.3 PRIMARY/EXPANSION RACK ASSEMBLY/DISASSEMBLY INSTRUCTIONS	5-4
5.3.1 Surge Suppressor Replacement Procedure	5-4
5.3.2 Headend Control Unit (HECU) Replacement Procedure	5-5
5.3.2.1 Computer Replacement Procedure	5-5
5.3.2.2 Monitor Replacement Procedure	5-7
5.3.2.3 Keyboard Tray Replacement Procedure	5-8
5.3.2.4 Mouse Replacement Procedure	5-10
5.3.3 Headend Interface Converter (HIC) Replacement Procedures	5-11
5.3.3.1 HIC Replacement Procedure	5-11
5.3.3.2 HIC Fan Replacement Procedure	5-12
5.3.3.3 HIC Power Supply Replacement Procedure	5-14

5.3.4 15 MHz Distribution Assembly Replacement Procedure	5-15
5.3.5 Optional +24V Power Supply Replacement Procedure	5-16
5.3.5.1 Optional +24V Power Supply Removal	5-17
5.3.5.2 Optional +24V Power Supply Replacement	5-17
5.3.6 Installing and Interconnecting Headend Expansion Rack	5-18
5.4 CMI ASSEMBLY DISASSEMBLY/ASSEMBLY INSTRUCTIONS	5-18
5.4.1 CMI Access	5-18
5.4.1.1 Opening the Assembly	5-18
5.4.1.2 Closing the Assembly	5-19
5.4.2 Power Extractor Replacement Procedure	5-20
5.4.3 Transceiver Replacement Procedure	5-22
5.4.4 Power Amplifier Replacement Procedure	5-24
5.4.5 Power Supply Replacement Procedure	5-25
5.4.6 Duosil Gasket Replacement Procedure	5-26
5.4.7 DC Harness Replacement	5-27
5.4.8 Replacement of Entire CMI Assembly	5-29
5.5 TROUBLESHOOTING	5-29
5.5.1 Upstream and Downstream System Power Levels	5-29
5.5.2 Alarms	5-30
5.5.2.1 Alarm Displays	5-30
5.5.2.2 Software Fault Detection	5-31
5.5.2.3 Alarm Message Prioritization and Status Polling	5-32
5.5.2.4 Alarm Information and Management	5-32
5.5.2.5 HIC Alarm Messages	5-33
5.5.2.6 CMI Alarm Messages	5-36
5.5.3 Manual Check and Fault Isolation Procedures	5-41
5.5.3.1 Primary/Expansion Rack Check and Fault Isolation Procedure	5-42
5.5.3.2 HIC Checkout and Fault Isolation Procedures	5-44
5.5.3.3 CMI Check and Fault Isolation Procedure	5-56
5.5.3.4 Upstream Checkout Procedures Using PING	5-66
5.6 WIRING DATA	5-69

LIST OF ILLUSTRATIONS

<u>Figure</u>	<u>Page</u>
1-1. PRIMARY RACK WITH INSTALLED HICs FRONT AND REAR VIEWS	1-4
1-2. TYPICAL HEADEND INTERFACE CONVERTER	1-5
1-3. TYPICAL CMI ASSEMBLY	1-6
2-1. PRIMARY RACK CONTROL AND INDICATOR LOCATIONS	2-1
2-2. OPTIONAL +24V POWER SUPPLY FRONT PANEL	2-2
2-3. HECU FRONT PANEL VIEW	2-3
2-4. HIC FRONT PANEL	2-4
2-5. HIC REAR PANEL	2-6
2-6. HIC RF SIGNAL FLOW DIAGRAM	2-7
3-1. OPERATING SYSTEM COMMAND AND DIALOG TREE	3-1
3-2. CONFIGURATION OPTIONS DIALOG	3-3
3-3. OPEN (CONFIGURATION FILE) DIALOG	3-3
3-4. INITIALIZATION OPTIONS DIALOG	3-4
3-5. TYPICAL HEADEND CONTROL PANEL DIALOG	3-6
3-6. TYPICAL ADD HIC DIALOG	3-7
3-7. TYPICAL RANGE ERROR MESSAGE	3-8
3-8. TYPICAL CONFIRM OPERATION DIALOG	3-9
3-9. TYPICAL DELETE CONTROL DIALOG FOR HIC	3-10
3-10. HECU SYSTEM ACCESS DIALOG	3-11
3-11. DECREASE PRIVILEGES DIALOG	3-11
3-12. CHANGE PASSWORDS DIALOG	3-12
3-13. LOGGING OUT DIALOG	3-13
3-14. HECU OPERATION PRIVILEGES DIALOG	3-13
3-15. HIC OPERATION PRIVILEGES DIALOG	3-14
3-16. CMI OPERATION PRIVILEGES DIALOG	3-14
3-17. TYPICAL CONFIRMATION DIALOG FOR SAVE COMMAND	3-15
3-18. LONWORKS UTILITIES DIALOG	3-15
3-19. COMMANDS SENT BY HECU DIALOG	3-16
3-20. HECU-HIC COMMUNICATIONS DIALOG	3-16
3-21. CONFIRMATION DIALOG FOR PURGING MESSAGE QUEUE	3-17
3-22. TYPICAL VERIFY OPERATION DIALOG FOR PURGING MESSAGE QUEUE	3-17
3-23. UNACKNOWLEDGED ALARMS DIALOG	3-18
3-24. TYPICAL ALARM INFORMATION MESSAGE	3-18
3-25. OPEN ALARMS DIALOG	3-19
3-26. ALARM HISTORY MESSAGE	3-19
3-27. CMI OUT OF SERVICE DIALOG	3-20
3-28. POLLING INTERVAL DIALOG	3-21
3-29. STATUS POLLING CONTROL DIALOG	3-21
3-30. HEADEND CONTROL PANEL: TOOLBAR	3-22
3-31. HECU DEVICE COLOR CODES DIALOG	3-23
3-32. ABOUT HECU SOFTWARE MESSAGE	3-23
3-33. TYPICAL NO STRING ENTERED DIALOG	3-24
3-34. SHUTDOWN ??? DIALOG	3-24
3-35. TYPICAL HIC CONTROL PANEL DIALOG	3-25
3-36. TYPICAL ADD CMI DIALOG	3-27
3-37. HIC UPSTREAM POWER DIALOG	3-29

3-38. UPSTREAM FREQUENCY DIALOG	3-30
3-39. PCS FREQUENCY DIALOG.....	3-31
3-40. HIC ADMINSTRATIVE DATA MESSAGE	3-32
3-41. HIC COMMUNICATIONS STATISTICS DIALOG	3-33
3-42. HIC PLL STATUS MESSAGE	3-34
3-43. HIC DOWNSTREAM POWER DIALOG	3-35
3-44. DOWNSTREAM CHANNEL DIALOG.....	3-36
3-45. REFERENCE AND CONTROL TONES DIALOG.....	3-37
3-46. CODE DOWNLOAD CONTROL DIALOG	3-38
3-47. HIC RESET CONTROL DIALOG.....	3-39
3-48. REASSIGNING CMI DIALOG.....	3-39
3-49. TYPICAL DELETE CONTROL DIALOG FOR CMI	3-40
3-50. HIC ALARMS ENABLE/DISABLE DIALOG	3-40
3-51. CMI GROUP CONTROL DIALOG	3-41
3-52. TYPICAL CMI CONTROL PANEL DIALOG	3-42
3-53. CMI UPSTREAM POWER DIALOG	3-44
3-54. CMI DOWNSTREAM POWER DIALOG	3-45
3-55. TRANSCEIVER CONTROL DIALOG	3-46
3-56. CMI ADMINISTATIVE DATA DIALOG.....	3-47
3-57. CMI COMMUNICATIONS STATISTICS DIALOG	3-48
3-58. CMI PLL STATUS MESSAGE.....	3-49
3-59. CMI RESET CONTROL DIALOG	3-50
3-60. CMI ALARMS ENABLE/DISABLE DIALOG	3-50
3-61. PING CMI DIALOG	3-51
3-62. US SETPOINT INITIALIZATION DIALOG	3-52
4-1. CMI SOURCE CODE FILENAME IN CODE DOWNLOAD CONTROL DIALOG	4-25
4-2. DOWNLOADING CODE DIALOG.....	4-26
4-3. PC -> CMI DOWNLOAD DIALOG	4-29
4-4. TRANSCEIVER CONNECTOR LOCATION	4-29
4-5. CMI INFORMATION DIALOG WITH DOWNLOAD OPTIONS.....	4-30
4-6. SUCCESSFUL DOWNLOAD MESSAGE	4-30
4-7. MESSAGE RESPONSE TIMEOUT DIALOG	4-31
4-8. RS-232 DOWNLOAD CABLE SCHEMATIC DIAGRAM	4-33
4-9. HIC SOURCE CODE FILENAME IN CODE DOWNLOAD CONTROL DIALOG.....	4-34
4-10. TYPICAL DOWNLOADING CODE MESSAGE FOR HIC	4-34
5-1. HIC DUST FILTER.....	5-2
5-2. HECU COMPUTER REAR VIEW.....	5-7
5-3. KEYBOARD TRAY REPLACEMENT	5-10
5-4. HIC REAR PANEL	5-12
5-5. CMI BOLT TIGHTENING SEQUENCE.....	5-19
5-6. CMI ASSEMBLY LOCATION DIAGRAM	5-20
5-7. POWER EXTRACTOR LOCATION DIAGRAM	5-22
5-8. TRANSCEIVER LOCATION DIAGRAM.....	5-23
5-9. POWER AMPLIFIER LOCATION DIAGRAM.....	5-24
5-10. POWER SUPPLY ASSEMBLY LOCATION DIAGRAM	5-26
5-11. DUOSIL GASKET REPLACEMENT	5-27
5-12. CMI HARNESS REPLACEMENT LOCATION DIAGRAM.....	5-29
5-13. PCS-OVER-CABLE RF POWER LEVELS AT 65% POLE.....	5-31
5-14. HIC POWER SUPPLY PIN ORIENTATION	5-47

5-15. HIC DOWNSTREAM REFERENCE AND CONTROL TONES	5-50
5-16. HIC DOWNSTREAM CDMA PEDESTALS	5-52
5-17. HIC UPSTREAM BPSK LEVEL MEASUREMENT	5-53
5-18. HIC UPSTREAM OUTPUT WITH VIDEO AVERAGING	5-56
5-19. SIMPLIFIED CMI FUNCTIONAL DIAGRAM	5-56
5-20. POWER SUPPLY MEASUREMENT TEST POINTS	5-58
5-21. OPERATOR FAULT ISOLATION PROCEDURE FOR <i>CMI NOT RESPONDING ALARM</i>	5-61
5-22. CMI WIRING HARNESS DIAGRAM	5-69

LIST OF TABLES

<u>Table</u>	<u>Page</u>
1-1. PCS-OVER-CABLE RACKS AND CMI PART NUMBERS	1-2
1-2. MAJOR ASSEMBLIES FOR RACK CONFIGURATIONS	1-3
2-1. RACK CONTROL AND INDICATOR LOCATIONS	2-2
2-2. FRONT PANEL CONTROLS AND INDICATORS FOR OPTIONAL POWER SUPPLY	2-3
2-3. HECU FRONT PANEL CONTROLS AND INDICATORS	2-4
2-4. HIC FRONT PANEL CONTROLS, INDICATORS, AND TEST POINTS	2-5
2-5. HIC REAR PANEL CONNECTORS	2-6
3-1. HEADEND CONTROL PANEL DIALOG FUNCTIONS	3-6
3-2. ADD HIC DIALOG FUNCTIONS	3-8
3-3. HEADEND CONTROL PANEL MENU COMMANDS	3-10
3-4. HIC CONTROL PANEL DIALOG FUNCTIONS	3-26
3-5. ADD CMI DIALOG FUNCTIONS	3-28
3-6. CMI CONTROL PANEL DIALOG FUNCTIONS	3-43
4-1. PCS CHANNEL TO FREQUENCY CROSS REFERENCE	4-9
4-2. CMI DOWNLOAD TROUBLESHOOTING TABLE	4-32
4-3. HIC DEFAULT RESET VALUES	4-37
4-4. CMI DEFAULT RESET VALUES	4-38
5-1. POWER SUPPLY ASSEMBLY	5-2
5-2. FAN REPLACEMENT PARTS	5-13
5-3. HIC ALARM MESSAGES	5-34
5-4. CMI ALARM MESSAGES	5-37
5-5. NOCC/HECU OPERATOR CHECKS FOR HIC ALARMS	5-48
5-6. HIC DOWNSTREAM REFERENCE AND CONTROL TONES OUTPUT	5-49
5-7. HIC DOWNSTREAM CDMA SIGNALS	5-50
5-7. HIC DOWNSTREAM CDMA SIGNALS (CONTINUED)	5-51
5-8. BPSK TONE LEVELS	5-52
5-9. CMI UPSTREAM PRIMARY AND DIVERSITY PEDESTAL MEASUREMENT	5-53
5-10. HIC DOWNSTREAM CDMA INPUT POWER	5-54
5-11. HIC UPSTREAM CDMA OUTPUT POWER	5-55
5-12. CMI TRANSCEIVER MODULE LED INDICATOR TRUTH TABLE	5-59
5-13. FORWARD LINK CONTINUITY TEST PROCEDURE	5-63
5-14. CABLE TILT TEST PROCEDURE	5-63
5-15. FORWARD LINK REFERENCE AND CONTROL TONES TEST PROCEDURE	5-64
5-16. CMI POWER CONFIGURATION PROCEDURE	5-64
5-17. CMI POWER CONFIGURATION PROCEDURE (CONTINUED)	5-65
5-18. REVERSE LINK TEST PROCEDURE	5-65

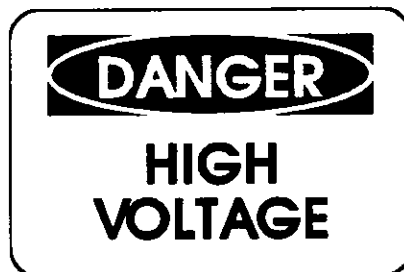

- High leakage current: The rack must be connected to Protective Earth ground before any connection is made to +24V prime power.
- High Voltages (115 Vac and 24 Vdc) are present within the equipment rack. Use extreme caution when working inside the rack.
- High voltages may exist in the near proximity of the CMI location, use standard CATV industry safety practices when working on an installed CMI.
- High voltages (60 Vac RMS) exist on the AC power cable to the CMI. Use extreme caution when removing the AC power cable to avoid coming in contact with the center conductor.
- High voltages (60 Vac RMS) can exist on the CMI antenna connections during a fault condition.
- Laboratory tests conducted in accordance with ANSI/IEEE C95.1-1992 show that a transmitting CMI poses no radiation hazard to persons in close proximity to the transmitting antenna. However, for added safety when working near a CMI, maintain a minimum distance of eight inches from the transmitting antenna.

SECTION 1 INTRODUCTION

1.1 SCOPE

This manual contains instructions for operating and maintaining the Sanders PCS-Over-Cable CMI/HIC system, Version 1.85. The system consists of:

- Headend Equipment (HEE) rack(s) with optional +24V Power Supply
- Rack-mounted Headend Control Unit (HECU)
- One or more rack-mounted Headend Interface Converter (HIC) units
- Cable Microcell Integrator (CMI) units installed on the CATV plant
- Operating software

The manual covers use of operating software for normal system operation and fault detection. It also covers troubleshooting and repair of the rack-mounted assemblies and the CMI.

1.2 ABOUT THIS MANUAL

1.2.1 Notation Conventions

This manual assumes that the user has a basic knowledge of the Windows™ operating system. Several typographic conventions and standard Windows™ terms are used in this manual when discussing the HECU operating software. They are as follows:

Mouse Commands - The HECU software uses only the left mouse button:

- “click” - press and release the left mouse button
- “double-click” - press and release left mouse button twice in quick succession

Menu Commands - Menu commands are shown in the form **MenuName/MenuCommand**, e.g. “Select **Privileges/Modify Privileges**.”

Button Names - Button names are shown in the form **ButtonName**, e.g. “To confirm selection, click **OK**.”

Key Names - Key names are spelled out and appear in small, bold capital letters, e.g. **ENTER, ESCAPE, CONTROL**.

Dialogs and Messages - Dialog and message titles appear in all upper case (capital) letters, and generally the name is referenced exactly as shown on the title bar, e.g., the HIC UPSTREAM POWER dialog. However, in cases where the dialog title varies according to privilege level, rack, or sector, the title is shortened to exclude this variable information unless the variable is important. For instance, an actual dialog title that may read “ADD HIC: PRIMARY RACK, HIC 1” usually will be shortened in the manual to “the ADD HIC dialog.” If the manual references a dialog title that includes a specific HIC or CMI number, the number is represented by the bracketed letter **n**: e.g., CMI CONTROL PANEL ALPHA SECTOR, CMI [n].

Dialog Options - Dialog options are shown in italics, e.g. "Type in the desired *PCS Frequency*." All instructions to "select" or "choose" an option imply clicking on that option, although options can be selected via the keyboard as well.

Keyboard Input - Instructions for keyboard entries start with "Type in...", and anything that should be typed in verbatim is shown in a different font. For example, "Type in config01.dtb in the *File Name* box."

Displayed Text - Text displayed in a dialog box will be shown in a different font, e.g. "The RESET HICS?? dialog displays the query Do you Want To Reset the HICs.

1.2.2 Manual Organization

The manual is organized into the following sections:

- Section 1 - Provides general system information.
- Section 2 - Defines the function of hardware front- and rear-panel controls and indicators.
- Section 3 - Defines the purpose of each element appearing in the user interface menus and dialogs.
- Section 4 - Provides normal operating procedures.
- Section 5 - Provides maintenance and troubleshooting procedures.

1.3 SYSTEM OVERVIEW

The PCS-Over-Cable CMI/HIC system equipment installed at the CATV headend facility and at remote locations includes the HEE rack(s) and their rack-mounted assemblies. There are two rack configurations, Primary and Expansion. Each HEE rack configuration may be equipped with an optional +24V Power Supply if an external 24V source is unavailable at the installation site. The CMI assemblies are installed on the messenger strands of the CATV plant throughout the service area. Table 1-1 lists rack and CMI part numbers.

Table 1-1. PCS-Over-Cable Racks and CMI Part Numbers

Equipment Configuration	Part Number
Headend Equipment Primary Rack	8303703G1
Headend Equipment Expansion Rack	8303702G1
Cable Microcell Integrator (CMI), Single Mode	8336701G1
Cable Microcell Integrator (CMI), Dual Mode	8336701G2

The HEE racks are a standard EIA design that holds standard 19-inch-wide rack-mounted assemblies. The two rack configurations are based on the identical rack hardware. The equipment rack dimensions are:

Height	76 in. (193.0 cm)
Depth	30 in. (76.2 cm), with keyboard tray unextended
Width	23 in. (58.4 cm)
Weight	290 lb.(131.5 kg), without HECU and HICs

Table 1-2 lists the major assemblies and components installed for each rack configuration. For a detailed assembly list for each rack configuration, refer to Section 2.

Table 1-2. Major Assemblies For Rack Configurations

Assembly item	Part No.	HEE	HEE
		8303703G1	8703702G1
Headend Control Unit (HECU)	8331364G1	X	N/A
15 MHz Distribution Assembly	8303715G1	X	X
Headend Interface Converter (HIC) (Qty 1-14)	8303704G1	X	X
Cable Assemblies	Various	X	X
Equipment Rack	8303739P1	X	X
Power Supply Assembly	8303743G1	(Optional)	(Optional)

1.3.1 Headend Equipment Primary/Expansion Rack Assemblies

The following paragraphs describe the major assemblies listed in Table 1-2 that are installed in the two rack configurations. The HEE expansion rack operates as a physical and functional extension of a primary rack, allowing for the use of up to 14 additional HICs. Figure 1-1 shows a typical headend primary rack with nine installed HICs. Each blank front panel is another HIC installation location. Refer to Section 2 for more information concerning installed HICs in either the primary or expansion rack.

1.3.1.1 Headend Control Unit (HECU)

As listed in Table 1-2, the HECU is used only in the HEE primary rack configuration. The major HECU hardware components are:

- Computer, Rack-Mountable, Pentium 100 MHz
- Monitor, Rack-Mountable
- Keyboard, Rack-Mount
- Mouse, PS/2
- Computer Power Cord
- Monitor Power Cord

The HECU monitors and controls the installed CMI and HIC units. It monitors various system parameters to verify that the units are operational and that the power levels are at the proper level. The HECU is the primary control/monitoring system that handshakes with the other units.

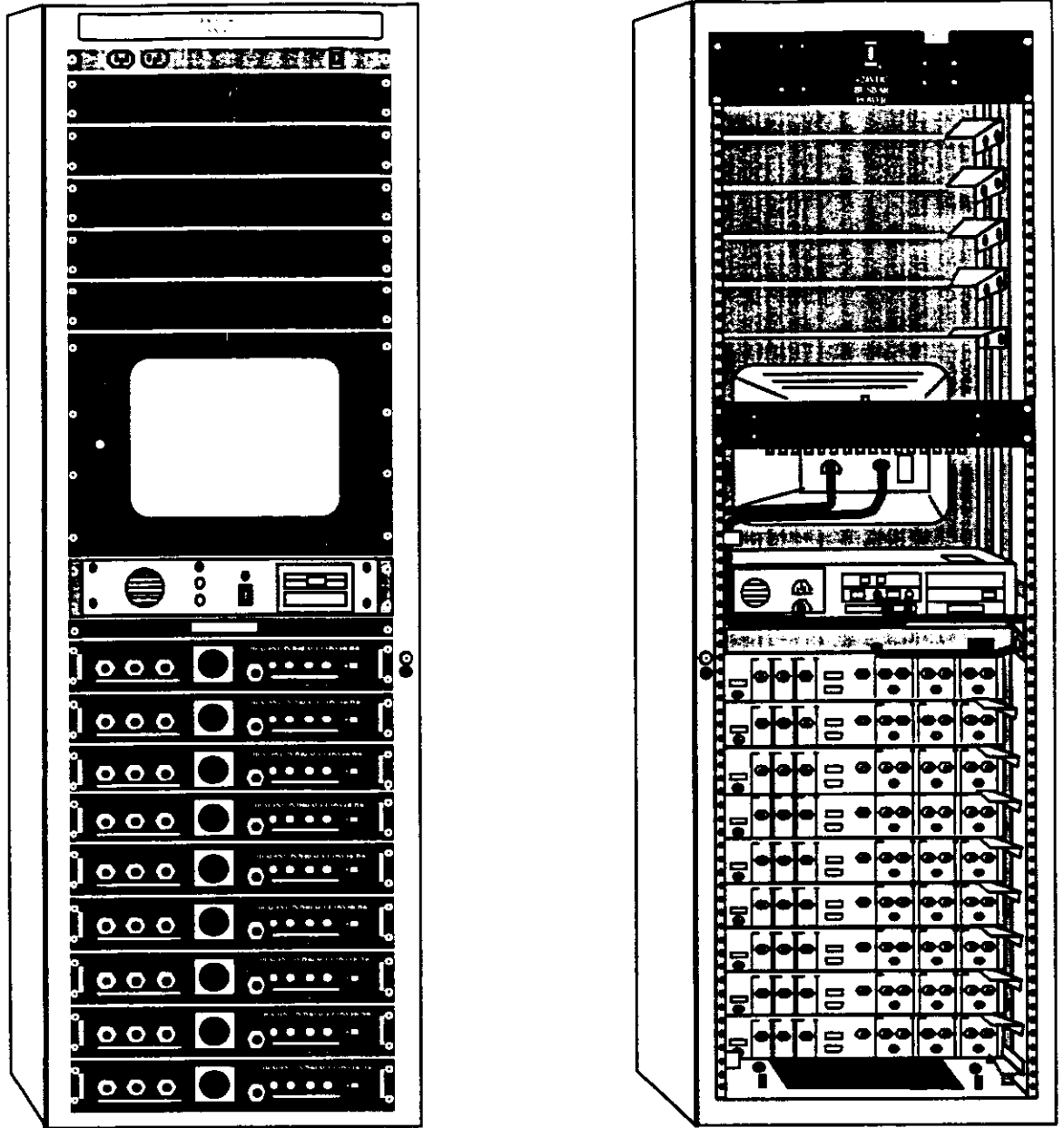

Figure 1-1. Primary Rack With Installed HICs Front and Rear Views

The HECU communicates with the HICs over an RS-485 interface via a Lonworks® card located in the computer. If it becomes necessary to remove this circuit card, removal must be performed in an ESD-secure environment. An ESD wrist strap must be worn at all times during this procedure.

The major HECU software components are:

- Microsoft® DOS Version 6.22
- Microsoft® Windows™ Version 3.11
- Software Drivers for custom HECU functions

1.3.1.2 15 MHz Distribution Assembly

Unlike the HECU, the 15 MHz Distribution Assembly is installed and used in both rack configurations. As shown in Figure 1-1, the 15 MHz Distribution Assembly is mounted in the rear of the rack. The distribution assembly requires +24V and 15-MHz inputs for operation and provides 16 reference outputs for distribution. Signal amplification for each 15-MHz output is approximately unity gain (0 dB). Unused ports are terminated with 50 ohms. Each installed HIC uses the 15-MHz reference signal.

1.3.1.3 Headend Interface Converter (HIC)

The HIC is the direct interface to the Base Transceiver Station (BTS) and CATV cable plant. It converts the downstream PCS frequencies from the BTS to a downstream CATV frequency to communicate with its associated CMI's, and it converts the upstream CATV signals from the CMI's to upstream PCS frequencies for the BTS.

The HIC uses rear panel connectors to interface with the BTS and CATV cable plant. One HIC supports multiple CMI units. The HIC assigns each CMI its frequency and gain levels. Each HIC supports up to three downstream Code Division Multiple Access (CDMA) channels in a standard 6-MHz CATV channel.

Each HIC consists of a single circuit card assembly (CCA) that contains the components for the three sector interfaces. A DC-operated fan cools the HIC by exhausting the air via the side panels. Figure 1-2 shows a typical HIC assembly. Refer to PCS-Over-Cable CMI/HIC System Implementation Manual, Document No. 8303691, for HIC installation in either a primary or expansion rack.

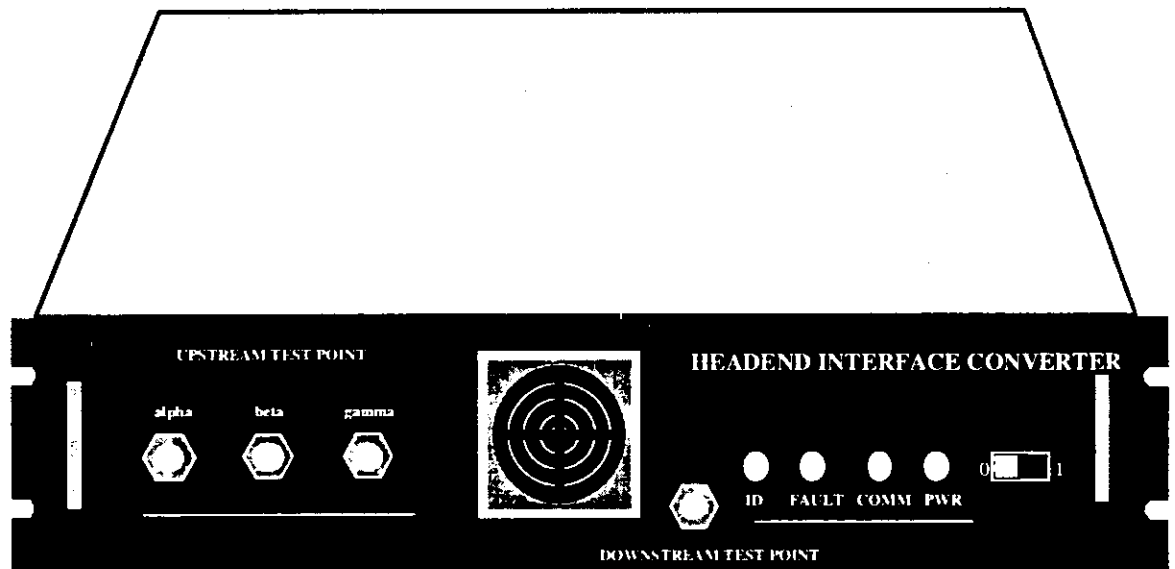

Figure 1-2. Typical Headend Interface Converter

1.3.1.4 Cable Assemblies

Cable assemblies provided with the various racks interconnect the installed assemblies within the rack. Cable assemblies are not provided for external interconnection between the rack and BTS or CATV plant. All external interfacing cables are provided at the site by the customer.

1.3.1.5 +24V Power Supply Assembly

For installation sites that do not provide an external +24V prime power source, an optional +24V Power Supply, part number 8303743G1, is available for rack installation. The +24V Power Supply operates using 115 Vac and provides +24V for the rack internal distribution. When installed in a rack, the +24V Power Supply uses the two top HIC locations. (With the power supply installed in a rack, the number of HICs allowed is 1-12).

1.3.2 Cable Microcell Integrator (CMI)

The CMI is the communications link between the PCS handset and the CATV cable plant. A typical CMI is shown in Figure 1-3. The CMI Assembly, part number 8336701G1 or 8336701G2, is comprised of the following major hardware CMI assemblies:

- Power Extractor Module
- Transceiver Module
- Power Supply Module
- Power Amplifier Module

The power extractor routes the power to the power supply and CATV cable signals to the internal CMI assemblies. The power supply converts the CATV cable plant power to power levels required on the transceiver module assembly and by the power amplifier.

The CMI is controlled by the HIC assembly in the HEE. The power amplifier is enabled/disabled by the assigned HIC unit and is used to boost the CDMA signal sent to the PCS handset via an antenna. The transceiver module assembly performs the handshaking with the assigned HIC unit and converts the CDMA signals to the appropriate frequencies.

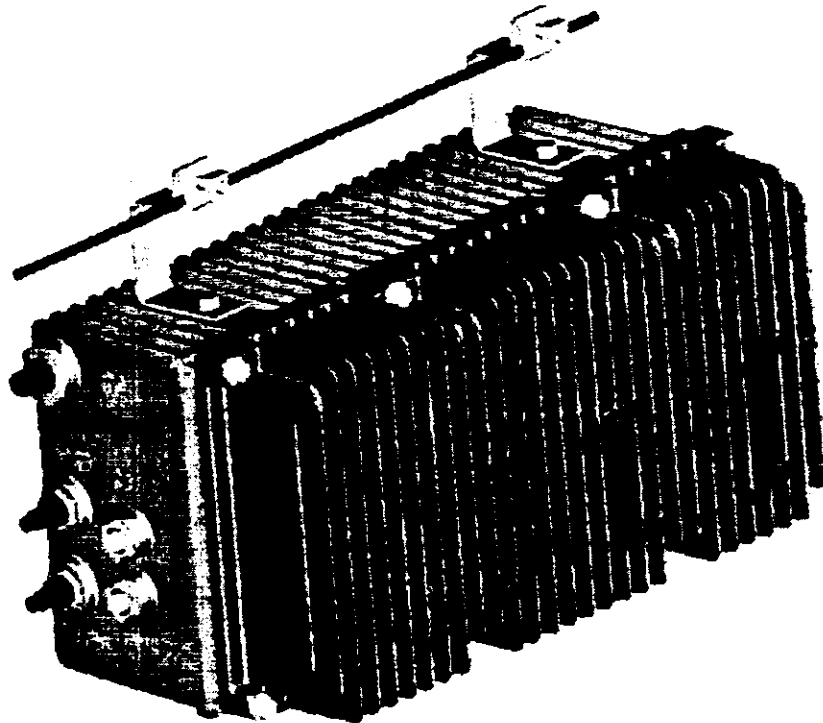

Figure 1-3. Typical CMI Assembly

1.3.2.1 Power Extractor Module

The Power Extractor is available in two configurations:

- The *Single Mode* configuration allows the CMI to operate with both the forward and reverse link CATV signals on a single CATV interface port (FWD/REV). In this mode the CMI can be configured to accept AC prime power from either CATV interface port.
- The *Dual Mode* configuration allows the CMI to operate with the forward and reverse link CATV signals on separate CATV interface ports. The forward link CATV signals are interfaced to the ALT/FWD CATV interface port and the reverse link CATV signals are interfaced to the FWD/REV CATV interface port. In this mode the CMI can be configured to accept AC prime power from either CATV interface port.

The AC power switch on the Power Extractor allows the installer/maintainer to select AC prime power for the CMI from either CATV interface port. The AC power switch also allows the user to shut off AC prime power to the Power Supply module without removing the Power Extractor.

The Power Extractor features a delay circuit that prevents a power surge on the reverse link when AC power is applied to the CMI. DC voltage for the delay circuit is routed to the Power Extractor through an integral two-conductor cable.

The Power Extractor accommodates field-replaceable, plug-in attenuator pads for both the forward and reverse CATV paths, and a field-replaceable, plug-in equalizer in the forward CATV path. These component locations are accessible when the CMI housing cover is open without the need to remove the Power Extractor. The CMI is shipped with no pads or equalizer installed. It will accept Scientific Atlanta model number PP-0 to PP-10 attenuator pads or equivalents and Scientific Atlanta model number EQ750 equalizers or equivalents.

The Power Extractor Module routes the following signals:

- External 60-Hz Quasi Square Wave input to the CMI Power Supply Module
- External 5–42 MHz CATV RF Reverse Link signals from the Transceiver Module
- External 52–750 MHz CATV RF Forward link signals to the Transceiver Module

1.3.2.2 Transceiver Module

The Transceiver contains a dual receiver and a transmitter, and incorporates both analog and digital signal processing and control. Upstream RF signals, originating in the PCS wireless domain, are received by both the primary and diversity receivers, processed and sent, via the CATV cable plant, to a headend location. Downstream signals, originating at the headend, travel, via the cable plant, to the CMI, are processed by the Transceiver, amplified by the Power Amplifier, then transmitted to the PCS users. There is one LED to indicate +5 VDC and three LEDs to indicate status codes.

1.3.2.3 Power Supply Module

The Power Supply Module requires a 60 Hz Quasi Square Wave (45-90 Vrms) input AC voltage. The power supply produces four DC voltages: +25V, +15V, +5V, and -15V. Test points are available for all input and output voltages. For overcurrent protection, the AC input is fused in the Power Supply Module.

1.3.2.4 Power Amplifier Module

The Power Amplifier Module operates in the 1930-1949.95 MHz passband. The Power Supply Module provides the required DC voltages for the amplifier. Typical Power Amplifier Module output is +34.8 dBm nominal.

1.4 SYSTEM STARTUP

Once the rack equipment is installed and energized, the operator selects and runs the installed program software. This displays the various menus and sub menus that allow control of all HICs and CMI's that are part of the system.

1.5 REMOTE OPERATION

The HECU, as installed in the HEE rack, can be operated from a remote location, such as a Base System Controller at a Network Operation Control Center (NOCC). The HECU provides three RS-232 serial ports operating at 9600 bps and modem port for remote user interface operating at 28.8 Kbps. In remote operation, the HECU display will remain active and indicate the present status but the HECU keyboard and mouse controls will be disabled.

In a remote mode of operation, the HECU reformats the information to ASCII text message format and transmits it to the NOCC for processing and display (alarms are transmitted on unsolicited basis as they are detected by the HECU). The HECU accepts ASCII messages from the remote operator and reformats them to Lonworks® protocols for processing by the HICs. The remote operator at the NOCC can perform local operator functions.

1.6 MENUS AND DIALOGS

Menus and dialogs are displayed on the HECU Monitor in standard Windows™ 3.1 format. Section 3 contains detailed menu and dialog information.

The major dialogs use color coded icons to provide device status information to the operator.

1.7 REFERENCE DOCUMENTATION

- Headend Equipment (Primary/Expansion) Rack and Cable Microcell Integrator, Implementation Manual for; Sanders Document No. 8334147
- Headend Control Unit (HECU)-associated vendor hardware/software documentation (Computer, Monitor, etc.)

1.8 ACRONYMS AND ABBREVIATIONS

AC	Alternating Current
bps	Bits Per Second
BTS	Base Transceiver Station
CATV	Cable Television
CCA	Circuit Card Assembly
CDMA	Code Division Multiple Access
CFE	Customer Furnished Equipment
CMI	Cable Microcell Integrator
DC	Direct Current
DOPC	Downstream Output Power Control
DPCC	Downstream Power Compensation Control
DS	Downstream
ESD	Electrostatic Discharge
HECU	Head End Control Unit
HEE	Headend Equipment
HIC	Headend Interface Converter
HRC	Harmonically Related Carriers
IF	Intermediate Frequency
IRC	Incrementally Related Carriers
Kbps	Kilobits Per Second
KHz	Kilohertz
MHz	Megahertz
NOCC	Network Operation Control Center
OAM&P	Operation, Administration, Monitoring & Provisioning
PCS	Personal Communication Services
RF	Radio Frequency
Rx	Receive
STD	Standard
Tx	Transmit
US	Upstream
Vac	Volts AC
Vdc	Volts DC

SECTION 2 CONTROLS AND INDICATORS

2.1 HEADEND PRIMARY/ EXPANSION RACK CONFIGURATIONS

2.1.1 *Front and Rear Panels*

The front and rear panels for the Headend Primary and Expansion Racks are similar. As previously mentioned, the difference between the two rack configurations is that the Headend Primary Rack contains the Headend Control Unit (HECU) and communications cables. Figure 2-1 shows a typical primary rack with one Headend Interface Converter (HIC) and optional +24V Power Supply installed. Table 2-1 lists the rack major assembly hardware contents.

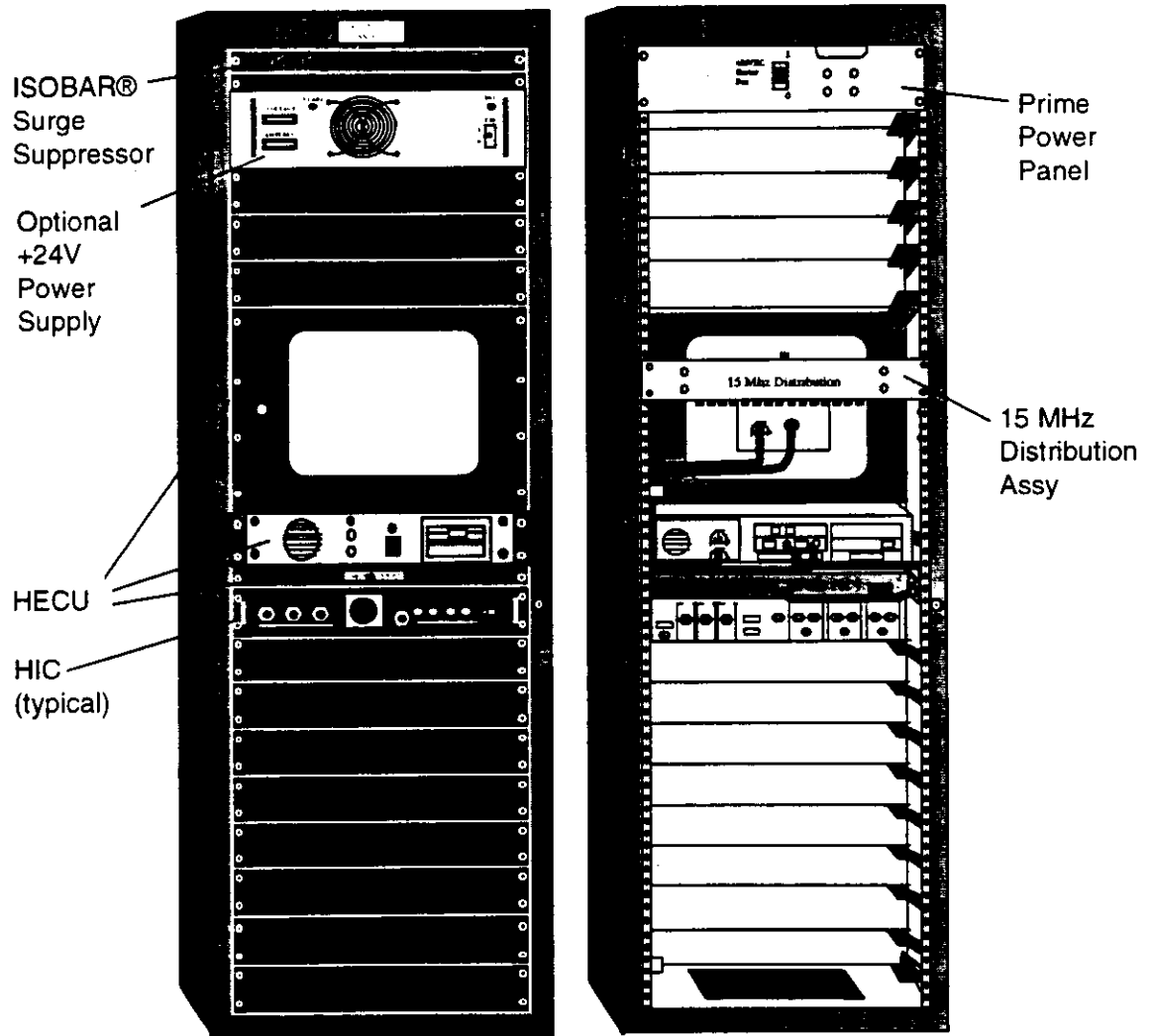

Figure 2-1. Primary Rack Control and Indicator Locations

Table 2-1. Rack Control and Indicator Locations

Item	Controls	Purpose
Primary Power Panel	+24V Circuit Breaker	Applies +24V power to equipment rack power bus.
15 MHz Distribution Assy	None	Receives 15 MHz reference signal from BTS for distribution to installed HICs
Optional +24V Power Supply	Refer to Table 2-2	Generates and applies +24V to +24V Circuit Breaker when external +24V power is unavailable.
HECU (Primary Rack)	Refer to Table 2-3	Controls operation of PCS-Over-Cable System.
Blank Panel (Expansion Rack)	None	Covers unused space in expansion rack.
HIC	Refer to Table 2-4 and Table 2-5	Controls assigned CMLs. (Each blank panel represents another HIC allocation.)
ISOBAR® Surge Suppressor	115 Vac Circuit Breaker	Applies 115 Vac to 12 outlets (10 rear and two front) Distributes 115 Vac to HECU and optional +24V Power Supply, when installed.

2.1.2 Optional Power Supply Configuration

At installation sites that do not provide +24V prime power, the rack can be configured to use a internal +24V Power Supply. The power supply is installed in the top two allocated HIC locations. Installing a power supply allows the rack to operate using only a 115-Vac external power source. In this configuration, the rack can hold a maximum of 12 HICs.

The installed +24V Power Supply is connected to the ISOBAR® Surge Suppressor rear outlet. When the power supply is energized, +24V is distributed to the associated rack +15 MHz Distribution and HIC assemblies. Controls and indicators for the +24V Power Supply are shown in Figure 2-2 and are listed in Table 2-2.

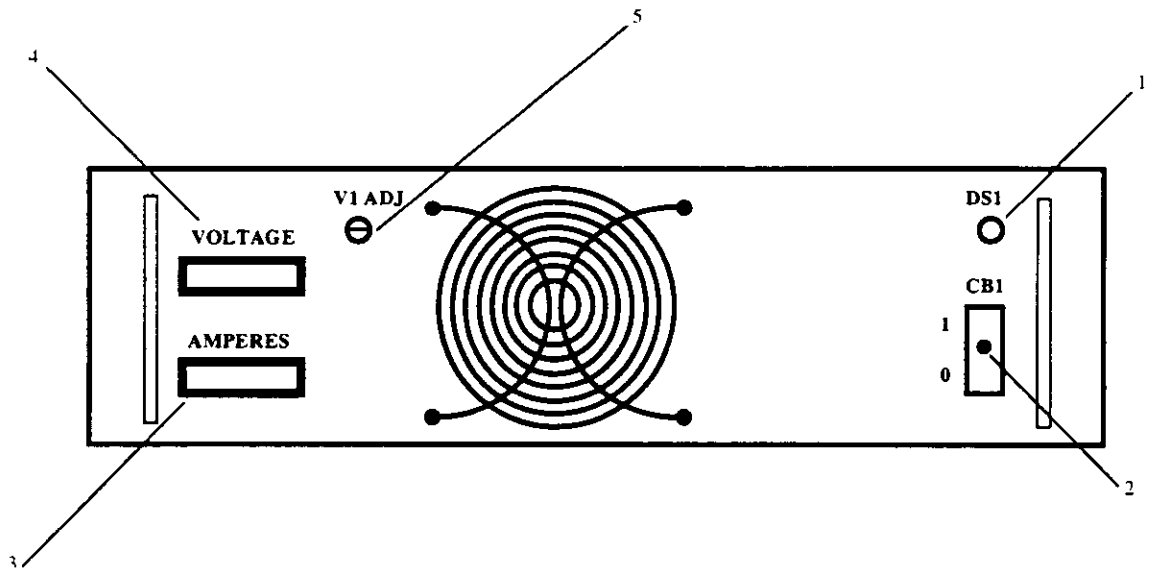

Figure 2-2. Optional +24V Power Supply Front Panel

Table 2-2. Front Panel Controls and Indicators for Optional Power Supply

Index	Control/Indicator	Purpose
1	DS1 Indicator	Indicates +24V Power Supply is on.
2	CB1 Circuit Breaker	Position 1 turns on power supply. Position 2 turns off power supply
3	AMPERES Readout	Indicates amount of current being drawn.
4	VOLTAGE Readout	Indicates power supply voltage setting.
5	V1 ADJ Control	Adjusts voltage level within some tolerance.

2.1.3 Headend Control Unit (HECU) Front Panels

The HECU consists of five major assemblies installed in the Headend Primary Rack. Figure 2-3 shows the HECU and Table 2-3 lists and identifies the purpose of each assembly. For more detailed information of the HECU, refer to the vendor data provided with the HECU equipment.

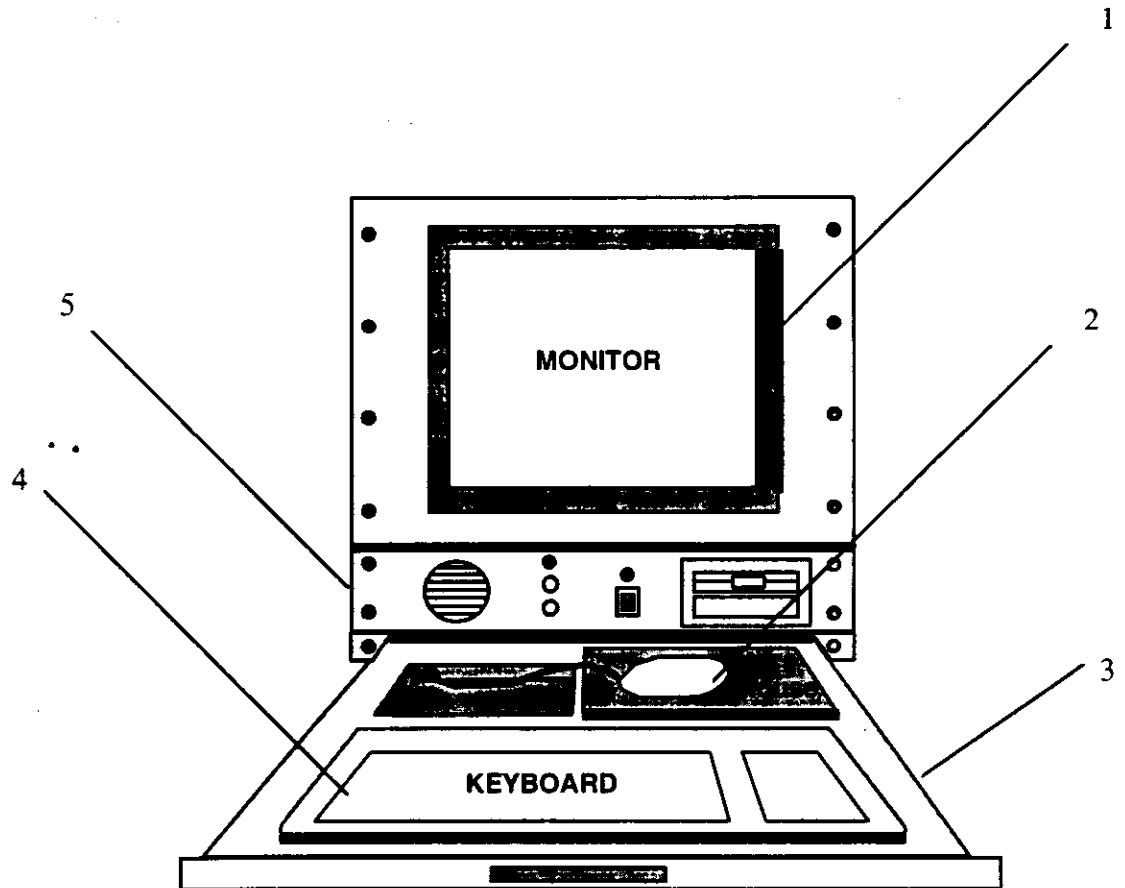

Figure 2-3. HECU Front Panel View

Table 2-3. HECU Front Panel Controls and Indicators

Index	Assembly	Control/Indicator	Purpose
1	Monitor	POWER ON/OFF switch (behind HECU door)	Applies and removes 115 Vac prime power to the Monitor.
2	Mouse	Standard mouse	Allows operator to move cursor and control display menus.
3	HECU Tray	None	Holds and stores HECU Keyboard, Mouse, and pad.
4	Keyboard	Standard keyboard	Allows operator to enter data and control each CMI/HIC using menus.
5	Computer	POWER push-button switch	Applies and removes 115 Vac prime power to Computer. Provides the software to operate and control the system.

2.1.4 Headend Interface Converter (HIC) Front and Rear Panels

The HIC front panel contains the operating controls, status indicators, and RF test points. In addition, the front panel holds a fan for air circulation in the HIC. Even though the HIC rear panel does not contain operating controls, it does contain the interface cables needed for operation. The interface cables are for power, CATV Plant and BTS signals.

2.1.4.1 HIC Front Panel

HIC front panel controls, indicators, and test points are located on the HIC front panel. The front panel provides visual and measurable indicators to check HIC operating status and the respective RF input/output signals. Figure 2-4 shows the HIC front panel and Table 2-4 lists the controls, indicators and measurement test points.

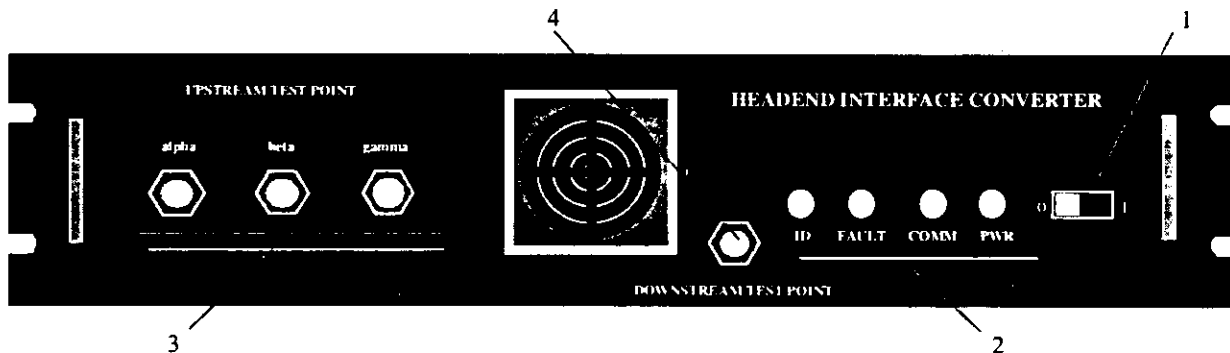

Figure 2-4. HIC Front Panel

Table 2-4. HIC Front Panel Controls, Indicators, and Test Points

Index	Control/Indicator	Purpose
1	Power On/Off switch	Position 1- Applies +24V power to the HIC Position 0-Removes +24V power from the HIC
2	Status LED Indicators	<p>ID -</p> <p>ON: On for approximately one second when the ADD_HIC_MSG is sent or when HIC control elements are changed: frequencies, enable/disable forward, reverse, control/reference signals</p> <p>OFF: On power-up or after reboot</p> <p>FAULT - indicates that a functional operating fault has occurred.</p> <p>ON: (1) When in download (2) When any enabled alarms are set (3) Flashing when in Watchdog Reset</p> <p>OFF: (1) When all enabled alarms are cleared (2) On power-up or after reboot</p> <p>COMM - flashing indicates that the HIC is capable of communicating with CMI</p> <p>ON: (1) Toggled when in Auto Statistics (2) Toggled when in Auto Gain</p> <p>OFF: On power-up or after reboot</p> <p>PWR - indicates that the HIC is energized and power is present on CCA.</p>
3	UPSTREAM TEST POINTS connectors	<p>alpha - Allows alpha sector upstream RF signal (5-42 MHz) to be monitored (-20 dB down from CATV input signal).</p> <p>beta - Allows beta sector upstream RF signal (5-42 MHz) to be monitored (-20 dB down from CATV input signal).</p> <p>gamma - Allows gamma sector upstream RF signal (5-42 MHz) to be monitored (-20 dB down from CATV input signal).</p>
4	DOWNSTREAM TEST POINT connector	Allows downstream RF signal (450-750 MHz) going to CATV Plant to be monitored (-20 dB down from the D/S CATV OUT connector).

2.1.4.2 HIC Rear Panel

HIC rear panel connectors are the main interface with the CATV Plant and BTS. Figure 2-5 shows the HIC rear panel connections, and Table 2-5 describes the purpose of each connector. Figure 2-6 provides further clarification of connector function by showing the RF signal flow for the HIC.

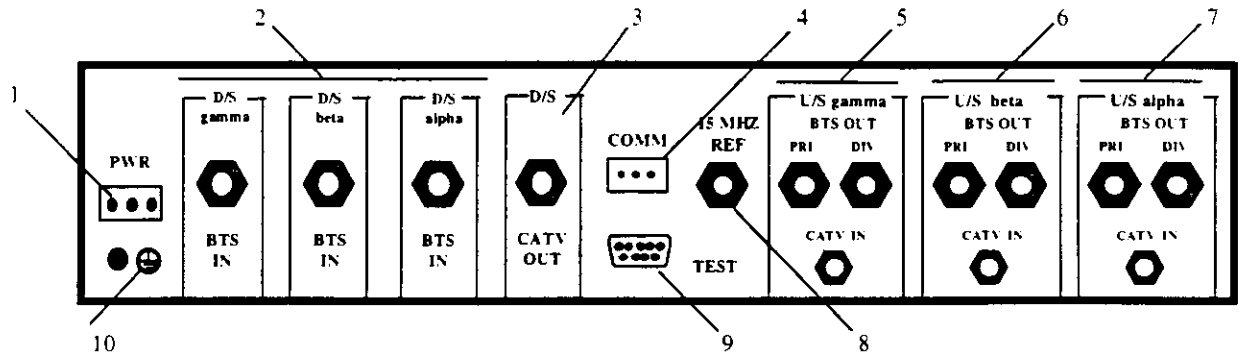

Figure 2-5. HIC Rear Panel

Table 2-5. HIC Rear PANEL Connectors

Index	Connectors	Purpose
1	PWR connector	Interface connector for +24V.
2	D/S alpha BTS IN connector beta BTS IN connector gamma BTS IN connector	Downstream BTS input (1930–1990 MHz) Provides alpha sector downstream RF signal for HIC from the BTS. Provides beta sector downstream RF signal for HIC from the BTS. Provides gamma sector downstream RF signal for HIC from the BTS.
3	D/S CATV OUT	Provides downstream HIC RF signal to CATV plant.
4	COMM connector	Provides RS-485 interface for communication between HECU and HIC.
5	U/S gamma PRI BTS OUT DIV BTS OUT CATV IN	Gamma sector HIC Upstream Provides gamma sector primary channel upstream RF signal from HIC to BTS. (1850–1910 MHz) Provides gamma sector diversity channel upstream RF signal from HIC to BTS. (1850–1910 MHz) Provides gamma sector CATV channel upstream RF signal (5–42 MHz) from CATV Plant to HIC.
6	U/S beta PRI BTS OUT DIV BTS OUT CATV IN	Beta sector HIC Upstream Provides beta sector primary channel upstream RF signal from HIC to BTS. (1850–1910 MHz) Provides beta sector diversity channel upstream RF signal from HIC to BTS. (1850–1910 MHz) Provides beta sector CATV channel upstream RF signal (5–42 MHz) from CATV Plant to HIC.
7	U/S alpha PRI BTS OUT DIV BTS OUT CATV IN	Alpha sector HIC Upstream Provides alpha sector primary channel upstream RF signal from HIC to BTS. (1850–1910 MHz) Provides alpha sector diversity channel upstream RF signal from HIC to BTS. (1850–1910 MHz) Provides alpha sector CATV channel upstream RF signal (5–42 MHz) from CATV Plant to HIC.
8	15 MHz REF connector	Interface connector for 15 MHz reference signal input from 15 MHz Distribution Panel.
9	TEST connector	Used for depot level diagnostics.
10	Ground terminal	Provides Protected Earth ground for HIC.

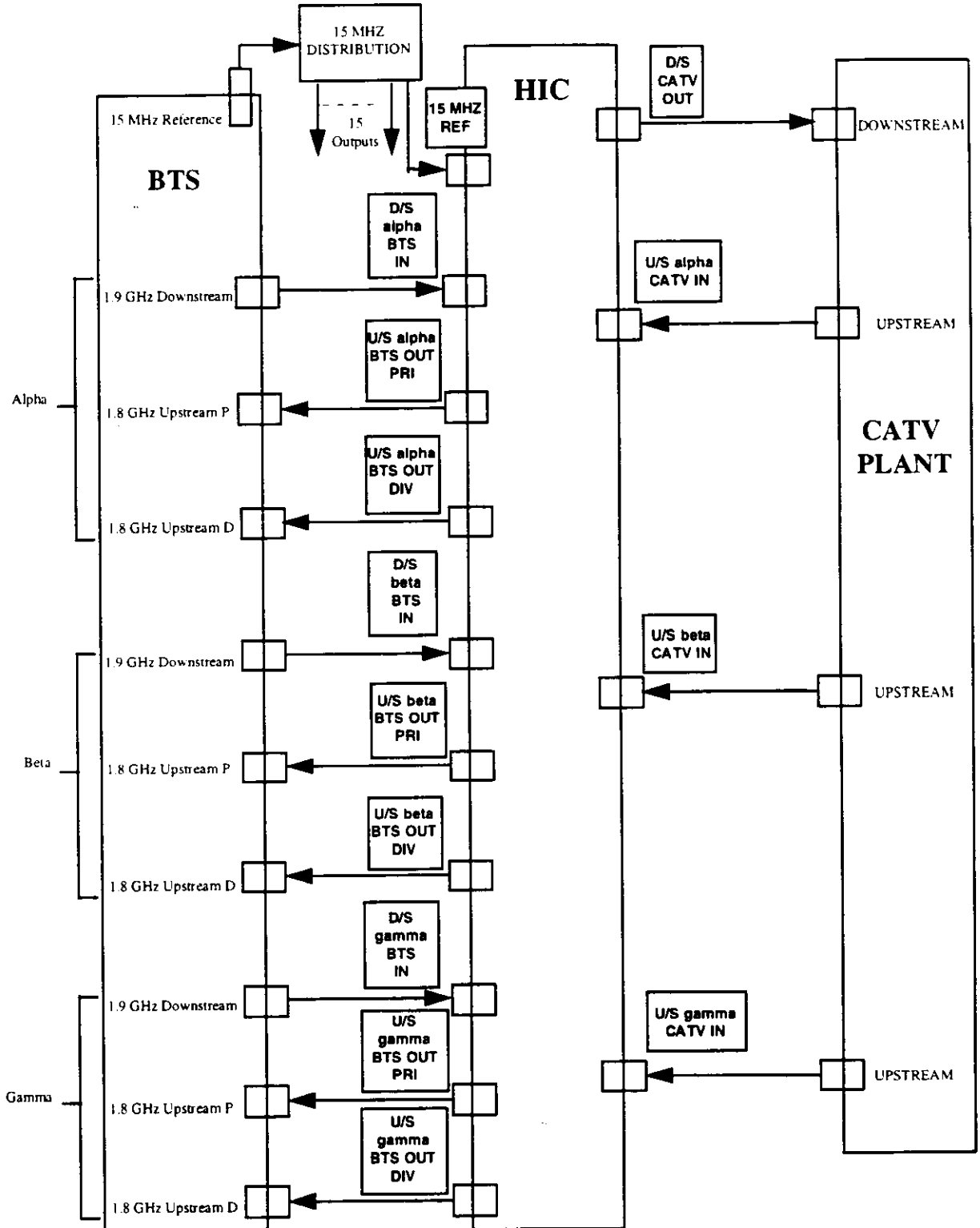

Figure 2-6. HIC RF Signal Flow Diagram

2.1.5 CMI

The CMI has no external controls or indicators.

2.2 PCS-OVER-CABLE CMI/HIC SYSTEM OPERATING INSTRUCTIONS

2.2.1 Operating Menus

Section 3 contains the illustrations and descriptions of the operating software user interface for the PCS-Over-Cable CMI/HIC System, Version 1.75.

2.2.2 Operating Procedures

Section 4 contains the operating procedures using the various menus and dialogs. The operating procedures include the equipment turn-on instructions and the sequence of events required for proper CMI/HIC operation.

2.2.3 Maintenance Instructions

Section 5 contains the maintenance instructions for the repair of the rack, HIC, and CMI. The maintenance instructions consist of scheduled maintenance procedures, assembly replacement procedures, alarm message definitions, and troubleshooting.

**SECTION 3
OPERATING MENUS AND DIALOGS**

3.1 OPERATING SOFTWARE USER INTERFACE

The operating menus and dialogs are displayed in the Windows™ 3.1 format on the HECU Monitor. Figure 3-1 shows the structural relationship of the commands and dialogs for the PCS-Over Cable CMI/HIC Version 1.87 operating program.

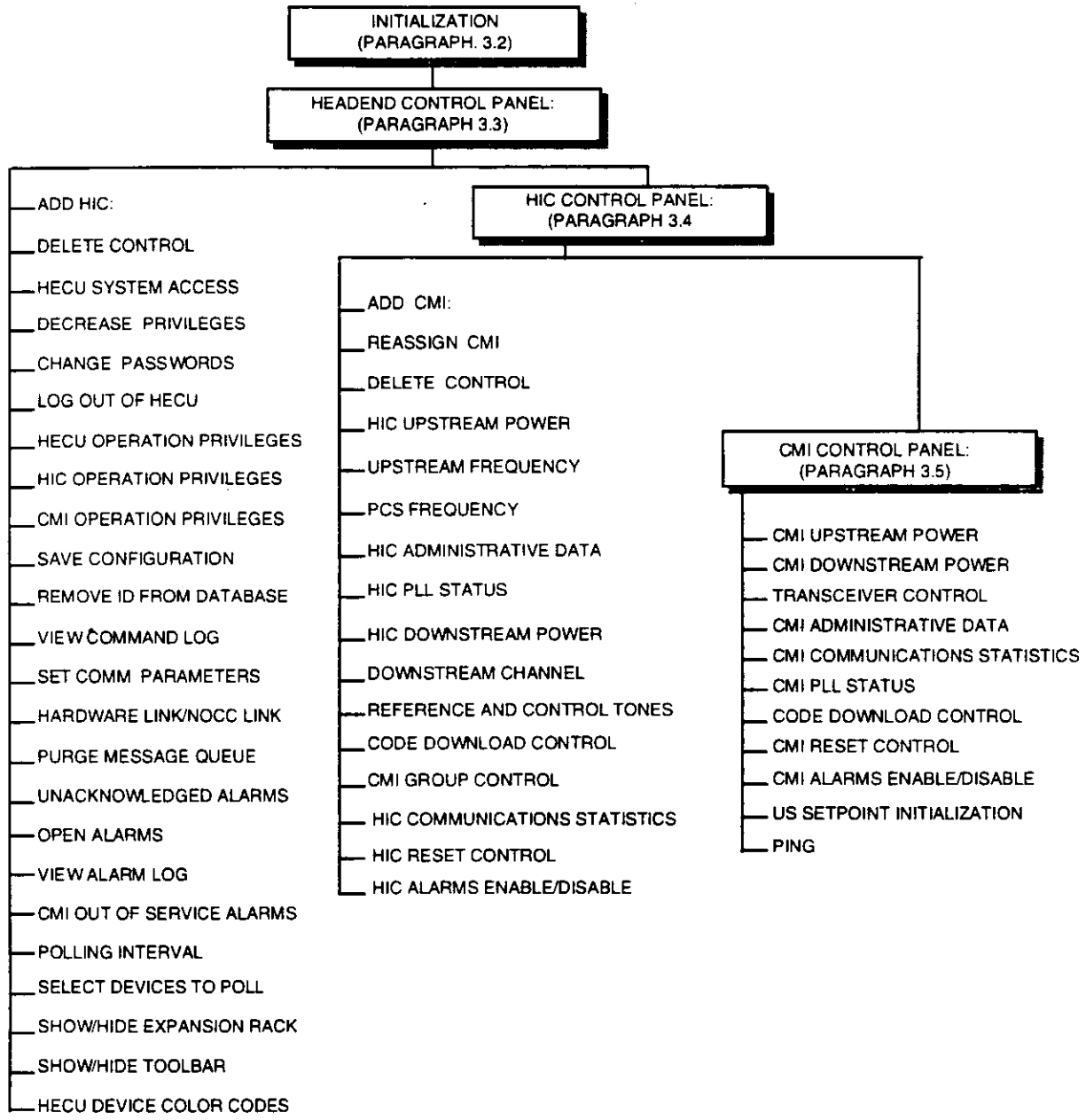

Figure 3-1. Operating System Command and Dialog Tree

After initialization, three primary control panel dialogs are used to control and monitor system operation:

- **HEADEND CONTROL PANEL Dialog** (paragraph 3.3) - Displays the current rack equipment configuration using color-coded icons to show the status of each HIC. After system initialization, this dialog allows the user to call up additional control dialogs for a selected HIC. The dialog title bar will read either HEADEND CONTROL PANEL: USER or HEADEND CONTROL PANEL: SUPER-USER, depending on the password-controlled access level. For discussion purposes, this dialog will be referred to as the HEADEND CONTROL PANEL dialog except for cases where a distinction is needed between User and Super-User.
- **HIC CONTROL PANEL dialog** (paragraph 3.3.12) - This dialog can be selected from the HEADEND CONTROL PANEL dialog to control and monitor a specific active HIC shelf number. To view this dialog for the selected HIC, the HIC must have been *added* with the ADD HIC dialog. The ADD HIC dialog can be accessed only through the HEADEND CONTROL PANEL dialog. The dialog title bar will read HIC CONTROL PANEL: PRIMARY RACK, HIC [n] for the primary rack and HIC CONTROL PANEL: EXPANSION RACK, HIC [n] for the expansion rack. The variable [n] represents the HIC number. For discussion purposes, this dialog will be referred to as the HIC CONTROL PANEL dialog.
- **CMI CONTROL PANEL dialog** (paragraph 3.5) - This dialog can be selected from the HIC CONTROL PANEL dialog to control and monitor a specific active CMI number in the Alpha, Beta, or Gamma sector. To view this dialog for a selected CMI, the CMI must have been *added* with the ADD CMI dialog, which is accessible only through the HIC CONTROL PANEL dialog. The dialog title bar will read CMI CONTROL PANEL: [s] SECTOR, CMI [n], where [s] represents the alpha, beta, or gamma sector and [n] represents the CMI number. For discussion purposes, this dialog will be referred to as the CMI CONTROL PANEL dialog.

3.2 INITIALIZATION

The HECU operating software normally is initialized by power-up or reset. It also may be initialized by double-clicking the HECU icon at the Windows™ Program Manager. As the LONWORKS® software is initializing, the message *Initializing LONWORKS Network Interface* is displayed, followed by the CONFIGURATION OPTIONS dialog.

3.2.1 CONFIGURATION OPTIONS Dialog

The CONFIGURATION OPTIONS dialog (Figure 3-2) is always the first dialog displayed by the operating software. The dialog displays the query: *Do you want to Restore a Pre-existing Configuration?*

No - Select to accept the default system configuration (no HICs or CMIs are installed) and display the HEADEND CONTROL PANEL dialog (paragraph 3.3.1).

Yes - Select to restore the system with the configuration that has been previously saved in the configuration file; the OPEN dialog (Figure 3-3) appears.

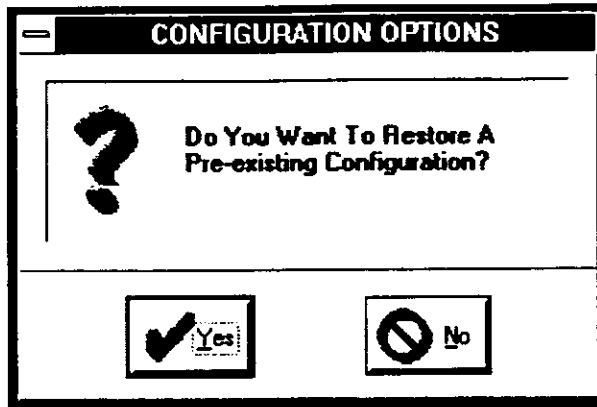

Figure 3-2. CONFIGURATION OPTIONS Dialog

CAUTION

If one or more devices has an alarm—for example, CMI Not Responding—while a configuration is being restored, it is very important to open the control panel dialog for each such device and determine whether the problem that caused the alarm is still present. A quick check typically includes manually updating the dialog status blocks (*Get Status*) and then observing whether any further alarms result from the status update. If the alarm simply is closed without determining whether the alarmed device has a continuing problem, the system monitoring software no longer can detect and report the problem. Once the alarm is closed, the HECU displays will show a normally operating system, *even though the alarmed device may be functionally deleted from the system.*

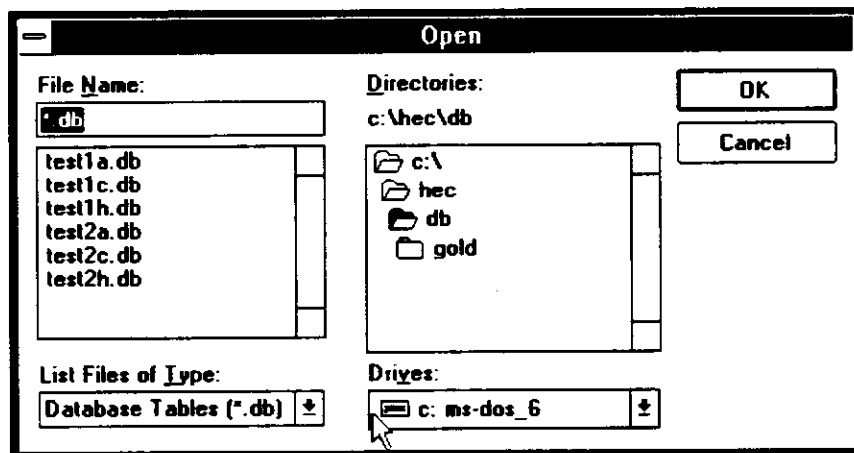

Figure 3-3. Open (Configuration File) Dialog

3.2.2 Open Dialog

File Name - Displays the saved configuration files. Selecting any one of the test2*. * files displayed will reload the last saved configuration. (The test1*. * files are used by the operating system for crash recovery. Selection of one of these files is not recommended.) To confirm selection, click OK.

Cancel - Select Cancel to exit from the Open dialog, without restoring a configuration, and display the HEADEND CONTROL PANEL dialog).

3.2.3 INITIALIZATION OPTIONS Dialog

If a configuration database file is selected, the INITIALIZATION OPTIONS dialog (Figure 3-4) appears with the query Do you want to Reinitialize the HICs and CMIs?

No - Select to restart the HECU operating software with the last saved HIC and CMI parameters. This option is usually used when the HECU was shut down while the HIC - CMI system was operating normally. Selecting No will not interrupt cellular phone traffic. Selecting No does not reinitialize HICs or CMIs and therefore will not re-acquire any CMI or HIC that may had been deleted.

Yes - Select to bring the HECU operating software back on line after first reinitializing all the HICs to last saved parameters, then reacquiring all the CMIs. This option is required whenever the CMIs and HICs are deleted prior to shutting down the HECU. Selecting Yes will re-acquire any attached CMIs or HICs that were deleted, either accidentally or intentionally, so long as they have two-way communications. Because the HICs are reinitialized during the Restore process, a short interruption in cellular phone traffic will occur when re-acquiring HICs and CMIs that have been operating normally while the HECU was shut down.

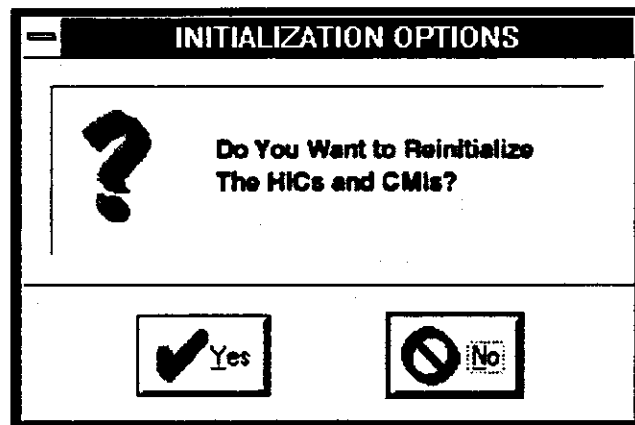

Figure 3-4. INITIALIZATION OPTIONS Dialog

3.3 HEADEND CONTROL PANEL MENUS AND DIALOGS

3.3.1 HEADEND CONTROL PANEL Dialog

NOTE

HICs and CMIs that have been *added* via the software user interface are referred to as *active*. This term differentiates such units from those that have been physically *installed* but have not been *activated* by the operating software.

The term **User** or **Super-User** appears in the title bar of this dialog (Figure 3-5) to define two different levels of access to system controls. Super-User access is by password only, and User access also can be controlled by password. The Super-User level has access to all menu commands and system controls. The User level has limited access to commands in the **Privileges** menu and is limited in access to individual HECU, HIC, and CMI controls as determined by the Super-User.

NOTE

User and Super-User access to software controls is determined by password. The software ships with the following default passwords:

User: toughguy
Super-User: jerky

Password inputs are not case sensitive.

Table 3-1 lists the HEADEND CONTROL PANEL dialog controls and indicators. These items serve as the top-level status and control interface for the HECU operator. Using the keyboard and mouse, the operator can activate, control and monitor each installed HIC.

An integral part of HIC status is provided by color coding the HIC icons. For example, the HECU communicates with the HIC units during preset polling intervals. Any communication interruption or loss changes the color of the HIC being polled from GREEN to RED, indicating an alarm.

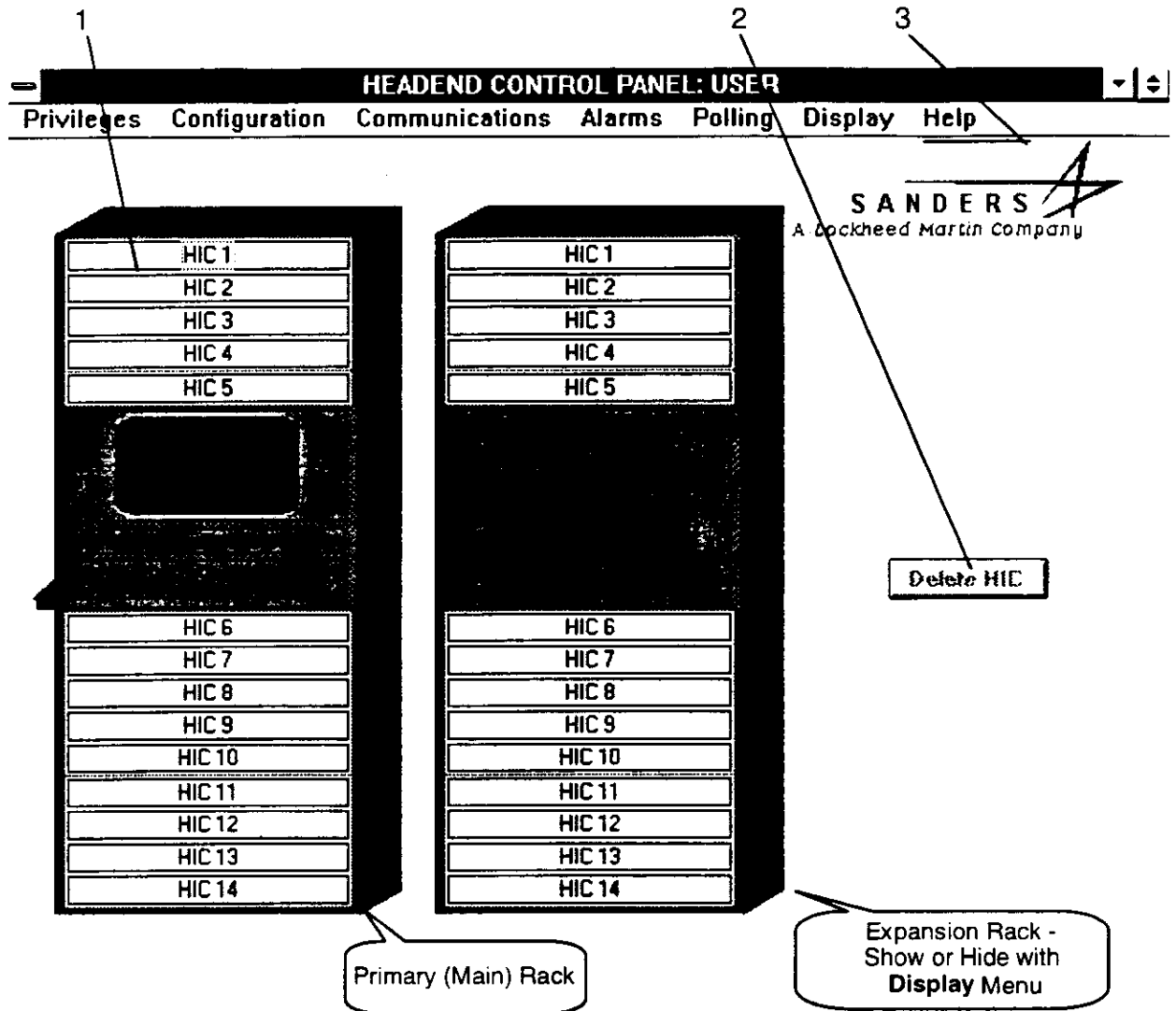

Figure 3-5. Typical HEADEND CONTROL PANEL Dialog

Table 3-1. HEADEND CONTROL PANEL Dialog Functions

Item	Control/Indicator	Function
1	HIC 1–HIC 14	Color coded icons provide equipment status for each HIC shelf. See paragraph 3.3.11.1 for color code descriptions. Double-click to display ADD HIC dialog (paragraph 3.3.2) for a non-active HIC, or HIC CONTROL PANEL dialog for an active HIC (paragraph 3.3.12).
2	Delete HIC	Select to display DELETE CONTROL dialog (paragraph 3.3.3).
3	Menu bar	Provides user control items and other dialogs. See paragraph 3.3.4 for detailed menu information.

3.3.2 ADD HIC Dialog

A new HIC from either rack can be added to the HECU monitoring and control routine by double-clicking any inactive (gray) HIC location on the HEADEND CONTROL PANEL dialog. Figure 3-6 shows the resulting dialog. The ADD HIC dialog allows various HIC parameters to be set or changed and provides the current status of the HIC sectors. The dialog title bar will read ADD HIC: PRIMARY RACK, HIC [n] or ADD HIC: EXPANSION RACK, HIC [n], depending on the selected rack. The [n] represents the selected HIC position. For discussion purposes, this dialog will be referred to as the ADD HIC dialog.

NOTE

The HIC positions in the rack are always numbered from top to bottom, HIC 1-HIC 14, without regard for installation of optional +24V power supply or physical location of installed HICs.

Table 3-2 describes the function of each control and indicator in ADD HIC dialog, and Section 4 contains information on how the dialog is used in operating procedures.

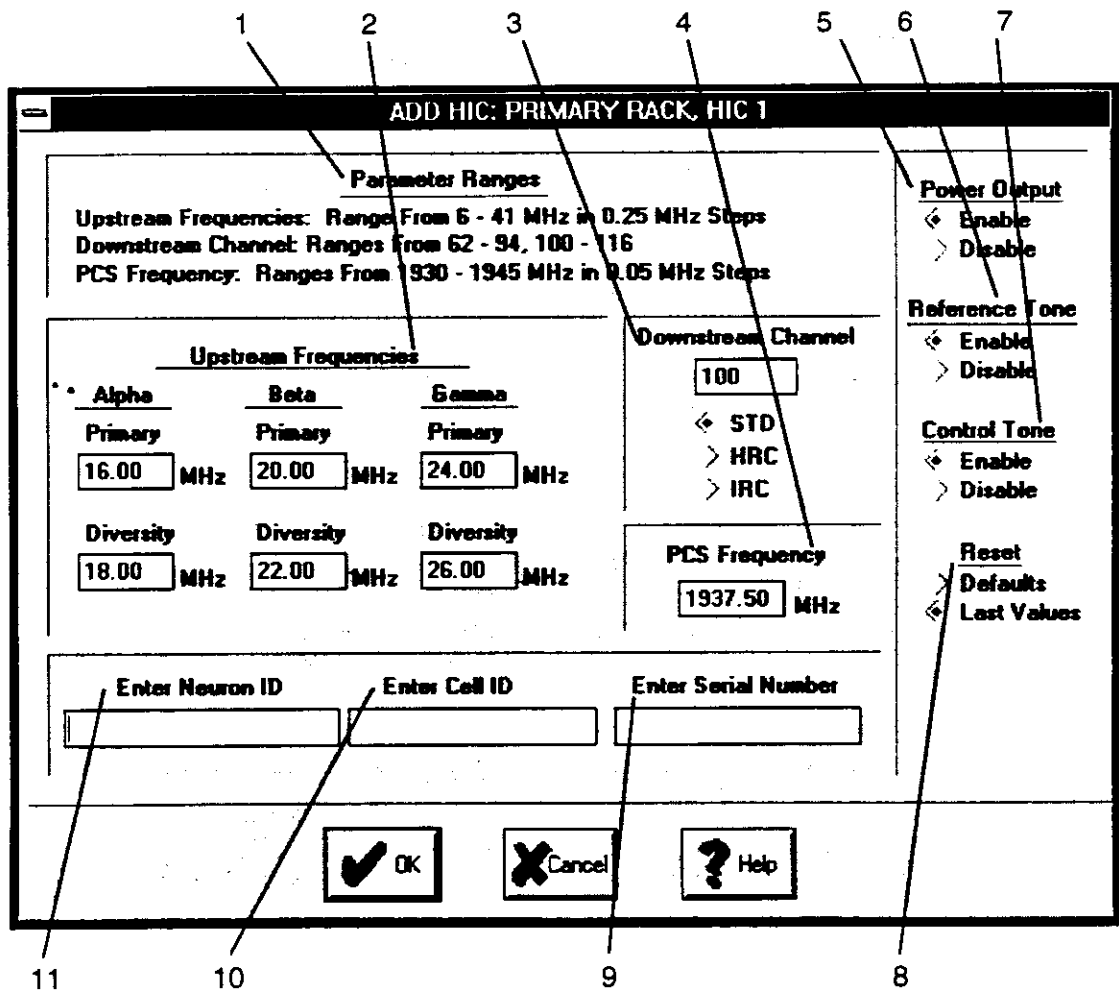

Figure 3-6. Typical ADD HIC Dialog

NOTE

Figure 3-7 is a typical range error message, displayed when selected parameter values are exceeded.

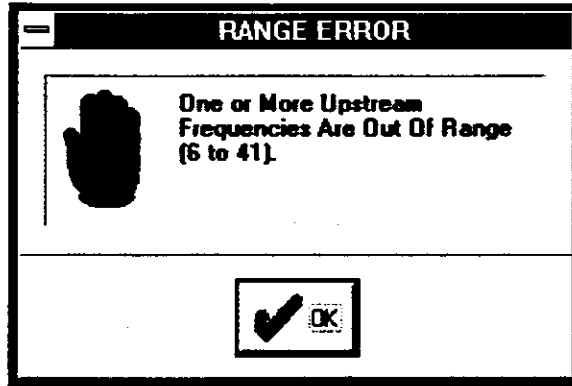

Figure 3-7. Typical RANGE ERROR Message

Table 3-2. ADD HIC Dialog Functions

Item	Control/Indicator	Function
1	Parameter Ranges	Message window that display the allowable ranges for upstream frequency, downstream channel, and PCS frequency.
2	Upstream Frequencies	Displays the default upstream receiver frequency settings for each HIC sector (Alpha, Beta, Gamma); data entry boxes allow setting of each Primary and Diversity frequency. Each Primary frequency must be set at least 2 MHz away from (normally below)—and not greater than 4.75 MHz away from—the related Diversity frequency.
3	Downstream Channel	Data entry box for setting the desired downstream channel; initially displays the default setting of 100. Buttons allow selection of <u>STD</u> (standard) <u>HRC</u> (Harmonically Related Carriers), or <u>IRC</u> (Incremental Related Carriers).
4	PCS Frequency	Data entry box for setting the PCS transmit frequency; initially displays the default setting of 1937.50. Frequency is entered to the nearest 50 kHz (0.05 MHz); the operating system rounds <i>down</i> an entry with greater resolution, e.g., 1940.24 is rounded to 1940.20.
5	Power Output	Buttons to enable/disable the downstream power output when the HIC is added. Defaults to <u>Enable</u> .
6	Reference Tone	Buttons to enable/disable the downstream reference tone. Defaults to <u>Enable</u> .
7	Control Tone	Buttons to enable/disable the downstream control tone. Defaults to <u>Enable</u> .
8	Reset	Buttons to set the mode in which the HIC will reset on a subsequent Power Up - Reset command. Defaults to <u>Last Values</u> .
9	Enter Serial Number	Data entry box for optional HIC serial number (up to 18 characters).
10	Enter Cell ID	Data entry box for optional cell ID (up to 18 characters).
11	Enter Neuron ID	Data entry box for 12-character Neuron® ID: This number <u>must</u> be entered in order to activate HIC.

3.3.3 Delete Control (HIC)

If the selected HIC has CMIs attached to it, the CONFIRM OPERATION dialog shown in Figure 3-8 is displayed when the Delete HIC button is selected at the HEADEND CONTROL PANEL dialog. The normal response is to select No and return the HIC CONTROL PANEL dialog to delete all attached CMIs. See paragraph 4.3.1.3 for further procedural information.

NOTE

It is important to delete all the CMIs in each sector of the selected HIC before deleting the HIC. The YES response at the CONFIRM OPERATION dialog is provided for emergency HIC deactivation only.

If the selected HIC has no attached CMIs, or if the response to the CONFIRM OPERATION query is YES, the DELETE CONTROL dialog shown in Figure 3-9 is displayed. The text of the query in the message box will vary to reflect the selected HIC.

- YES - Normally selected when wishing to ensure that communications with the selected HIC are operating normally before deactivating the unit. A message window will confirm communication status. If communication is successful, the selected unit is deactivated. If not, the DELETE CONTROL dialog is displayed again.
- NO - Normally selected when communication with selected HIC has been lost; the unit is deactivated immediately without further attempts to communicate with it.
- CANCEL - ends the display of the dialog.

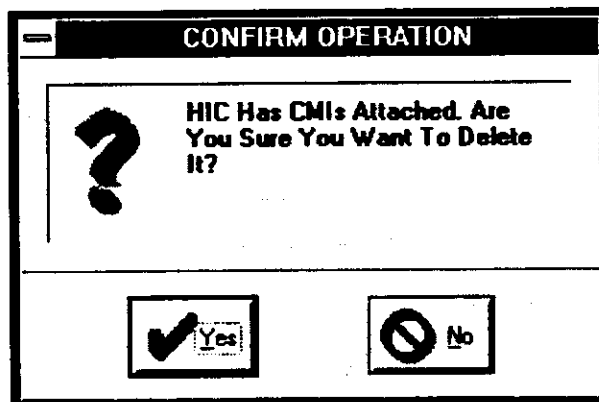

Figure 3-8. Typical CONFIRM OPERATION Dialog

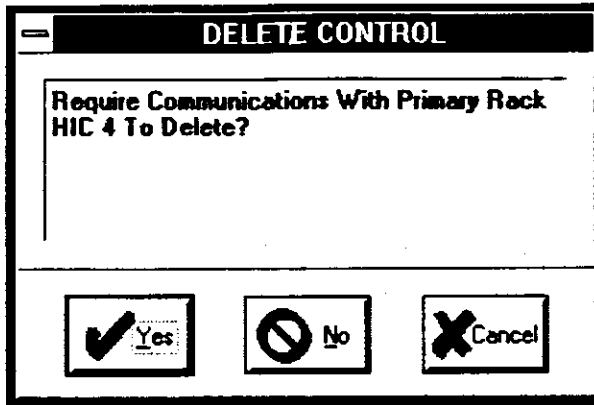

Figure 3-9. Typical DELETE CONTROL Dialog for HIC

3.3.4 Headend Control Panel Menu Commands

The HEADEND CONTROL PANEL dialog has a menu bar containing commands for system security, housekeeping, display control, system settings and system alarms. The commands for each menu item are listed in Table 3-3 and described in paragraphs 3.3.5 through 3.3.11.

Table 3-3. HEADEND CONTROL PANEL Menu Commands

Privileges (Para. 3.3.5)	Configuration (Para. 3.3.6)	Communications (Para. 3.3.7)	Alarms (Para. 3.3.8)	Polling (Para. 3.3.8.4)	Display (Para. 3.3.10)	Help (Para. 3.3.11)
Increase Privileges	Save	Hardware Link	Show Unacknowledged Alarms	Set Polling Interval	Show Expansion Rack	Color Codes
Decrease Privileges		NOCC Link	Show Open Alarms	Select Devices to Poll	Hide Expansion Rack	About HECU
Change Password		Remove ID From Database	View Alarm Log		Show Toolbar	
Logout of HECU		View Command Log	CMI Out Of Service Control		Hide Toolbar	
Modify Privileges		Set Comm Params				
		Purge Message Queue				

3.3.5 Privileges Menu Commands

3.3.5.1 Increase Privileges

Selecting **Privileges/Increase Privileges** displays the HECU SYSTEM ACCESS dialog (Figure 3-10) for entering a password. This command is used if the system is set for User access and a change must be made that is authorized only at the Super-User level. This command also is used when an operator requests system access after logging out via the **Privileges/Logout of HECU** command (see paragraph 3.3.5.4). The operator must enter either the assigned Super-User password or User password (if assigned) to gain access. If the Super-User password is entered, the title bar of the resulting dialog reads HEADEND CONTROL PANEL: SUPER-USER.

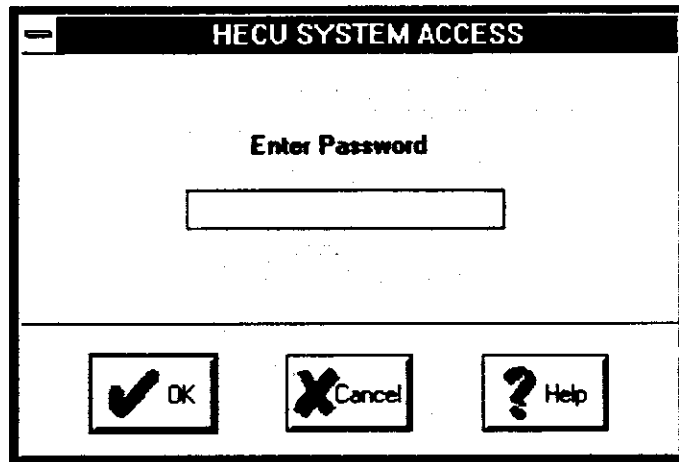

Figure 3-10. HECU SYSTEM ACCESS Dialog

3.3.5.2 Decrease Privileges

Selecting **Privileges/Decrease Privileges** displays the **Decrease Privileges** dialog (Figure 3-11). This command is used to return system privileges to User level after making an adjustment at Super-User level.

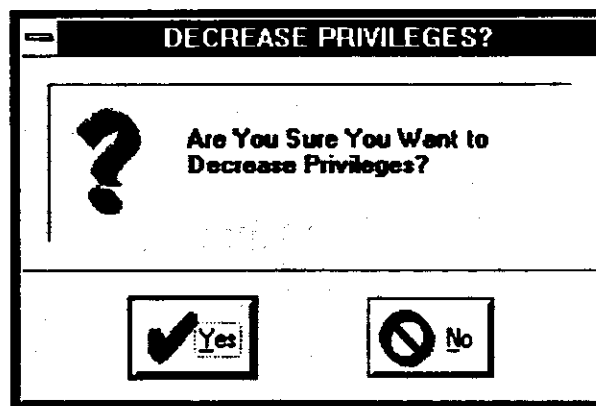

Figure 3-11. DECREASE PRIVILEGES Dialog

3.3.5.3 Change Password

From a HEADEND CONTROL PANEL: SUPER-USER dialog, the password for both Super-User) and User can be changed. When **Privileges/Change Password** is selected,

the dialog shown in Figure 3-12 appears. Either password can be changed to any string of alphanumeric characters (a-z, A-Z, 0-9). Alphabetic characters may be any combination of upper and lower case. Passwords may be up to 20 characters in length.

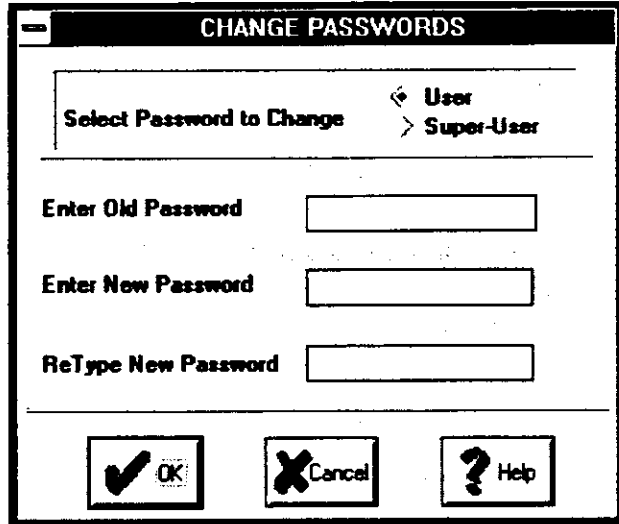

Figure 3-12. CHANGE PASSWORDS Dialog

3.3.5.4 Logout of HECU

Both the User and Super-User have the option to log out of the HECU. When the **Privileges/Logout of HECU** option is selected, the LOGGING OUT dialog (Figure 3-13) appears. Logging out of the HECU does not change the operational state of the HIC/CMI system or the HECU software monitoring functions. When **Yes** is selected to confirm the desire to log out, the title bar of the HEADEND CONTROL PANEL dialog changes to HEADEND CONTROL PANEL: INTERFACE DISABLED. All controls on the HEADEND CONTROL PANEL dialog are disabled except for the **Privileges/Increase Privileges** menu command. The **Privileges/Logout of HECU** command is useful in preventing access to system controls by unauthorized personnel.

Logging out of the HECU is not to be confused with “*exiting*” or “*shutting down*” the HECU software program. Exiting the program can be limited to the Super-User level and is normally done only for HECU maintenance. See Section 4 for system exit procedures.

NOTE

When logged out, an operator must enter either the User or Super-User password to log back into the system. The **Privileges/Increase Privileges** command displays the dialog for entering the password.

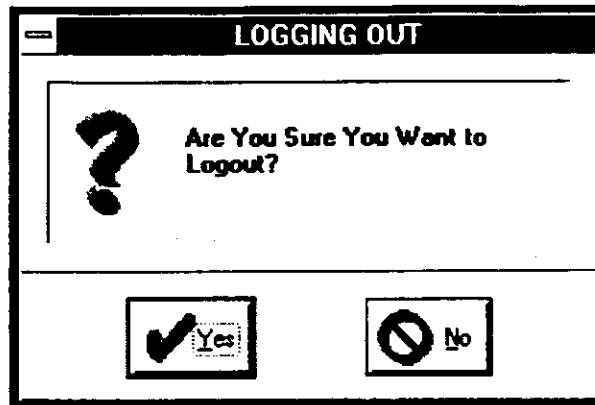

Figure 3-13. LOGGING OUT Dialog

3.3.5.5 Modify Privileges

This selection displays another pull-down menu with three commands. Each command accesses a dialog that permits the Super-User to customize which controls for the HECU, HIC, and CMI are authorized for User access.

3.3.5.5.1 Mod HECU Privileges

Selecting this command displays the HECU OPERATION PRIVILEGES dialog (Figure 3-14).

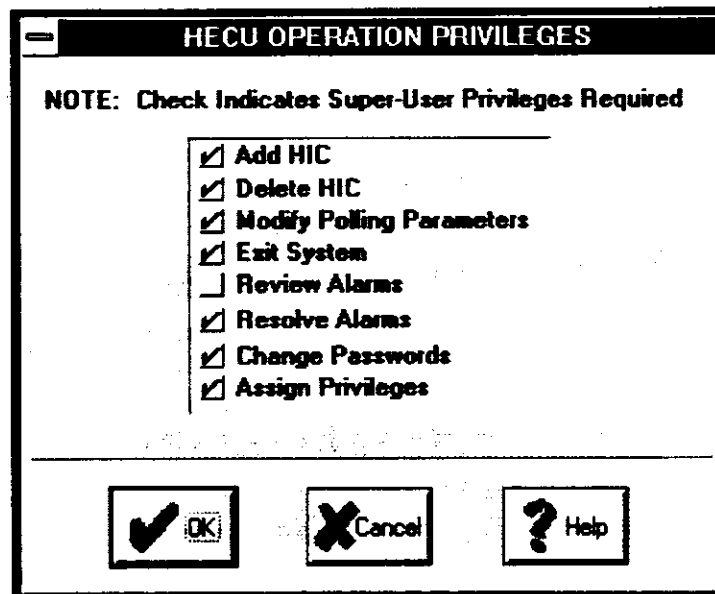

Figure 3-14. HECU OPERATION PRIVILEGES Dialog

3.3.5.5.2 Mod HIC Privileges

Selecting this command displays the HIC OPERATION PRIVILEGES dialog (Figure 3-15).

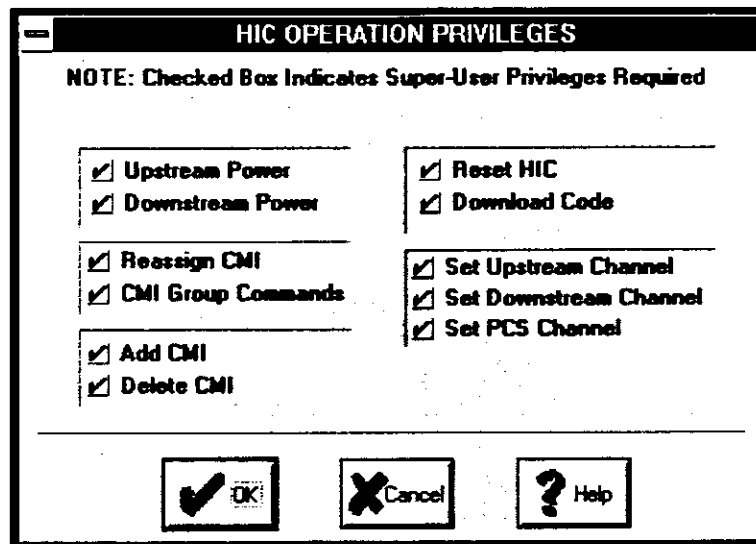

Figure 3-15. HIC OPERATION PRIVILEGES Dialog

3.3.5.5.3 Mod CMI Privileges

Selecting this command displays the CMI OPERATION PRIVILEGES dialog (Figure 3-16).

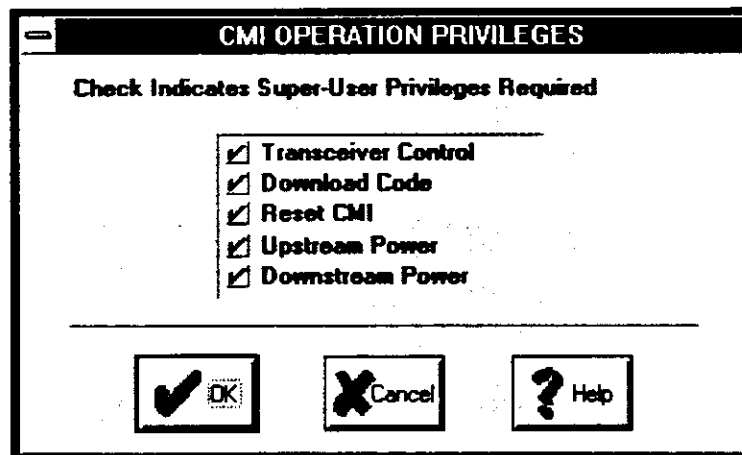

Figure 3-16. CMI OPERATION PRIVILEGES Dialog

3.3.6 Configuration Menu Commands

The **Configuration** menu item contains the **Save** command. This command saves the current system configuration so that if the system must be taken out of service, the same configuration can be restored easily when the system is brought back into service. The configuration includes all the settings for each active HIC and CMI. Once a system is set up and configured as desired, the setup configuration then can be saved simply by selecting **Configuration/Save** from the menu bar. When **Save** is selected, the CONFIRMATION dialog (Figure 3-17) is displayed. Once a configuration is saved, it can be used to restore the system configuration.

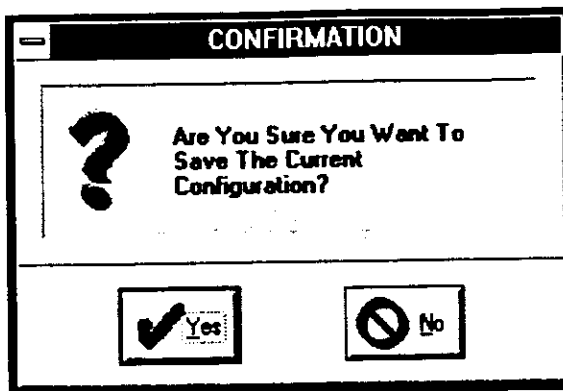

Figure 3-17. Typical CONFIRMATION Dialog for Save Command

3.3.7 Communications Menu Commands

3.3.7.1 *Hardware Link*

Selecting the **Communications/Hardware Link** command displays a pull-down menu of two communication links between the HECU and the HICs, **RS-232 Link** or **Lonworks Link**. Selection of one link automatically disables the other. The Lonworks® link is used in normal operation, while the RS-232 link is used for factory-level diagnostics. The default state at power-up is **Lonworks Link**.

3.3.7.2 *NOCC Link*

This command is selected to either activate or deactivate the communications link with the Network Operations & Control Center (NOCC). The default state at power-up is **Activate**.

3.3.7.3 *Remove ID From Database*

Selecting **Communication/Remove ID From Database** displays the command **Remove ID from Database** which, when selected, displays the LONWORKS UTILITIES dialog (Figure 3-18). This dialog allows deletion of a specific Neuron® identification number from the operating program database and is used under the following set of conditions:

- Attempt to add a HIC or CMI is unsuccessful
- Second attempt is also unsuccessful, and the message "Neuron ID already exists in database" is displayed

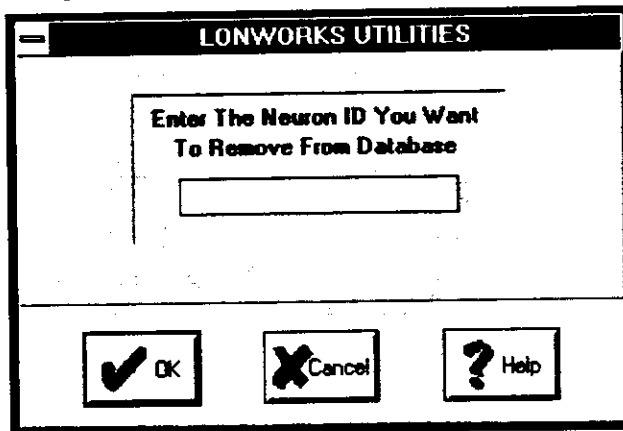

Figure 3-18. LONWORKS UTILITIES Dialog

3.3.7.6 Purge Message Queue

This command purges the HIC - CMI message queue. Because this action may result in the loss of important system data such as new power and frequency settings, a double confirmation is required. Selecting **Purge Message Queue** displays a CONFIRMATION dialog (Figure 3-21); selecting **Yes** displays a VERIFY OPERATION dialog (Figure 3-22).

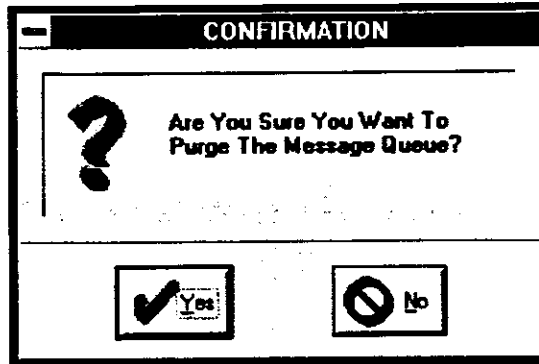

Figure 3-21. CONFIRMATION Dialog for Purging Message Queue

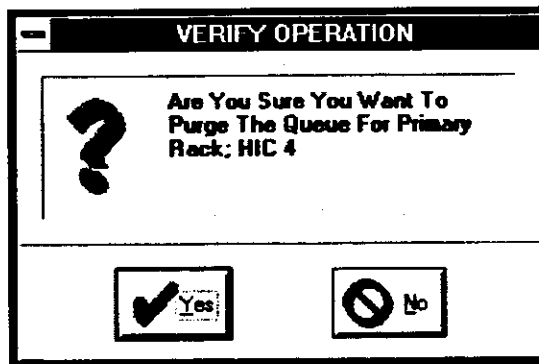

Figure 3-22. Typical VERIFY OPERATION Dialog for Purging Message Queue

3.3.8 Alarms Menu Commands

The **Alarms** pull-down menu selection is typically used when the color of a HIC or CMI icon indicates an alarm. (See paragraph 3.3.11.1 for color code definitions.) The **Alarms/Show Unacknowledged Alarms** command displays a

dialog with a list of alarms that the operator has not yet acknowledged (the affected icon blinks until the alarm is acknowledged). The **Alarms/Show Open Alarms** command displays a dialog with a list of alarms that are unresolved and may require corrective action. The **Alarms/View Alarm Log** command opens a window to display the contents of the alarm log. The **Alarms/CMI Out of Service Control** command opens the CMI OUT OF SERVICE dialog. This dialog allows the Super-User to enable or disable the Out of Service indicator and to select the types of alarms for which the Out of Service indicator will be displayed (see paragraph 3.3.11.1).

3.3.8.1 Unacknowledged Alarms

A typical UNACKNOWLEDGED ALARMS dialog is shown in Figure 3-23. Select Acknowledge to remove a selected alarm(s) from the list. Select Review Details to display the ALARM INFORMATION Message Window (Figure 3-24) for a selected alarm.

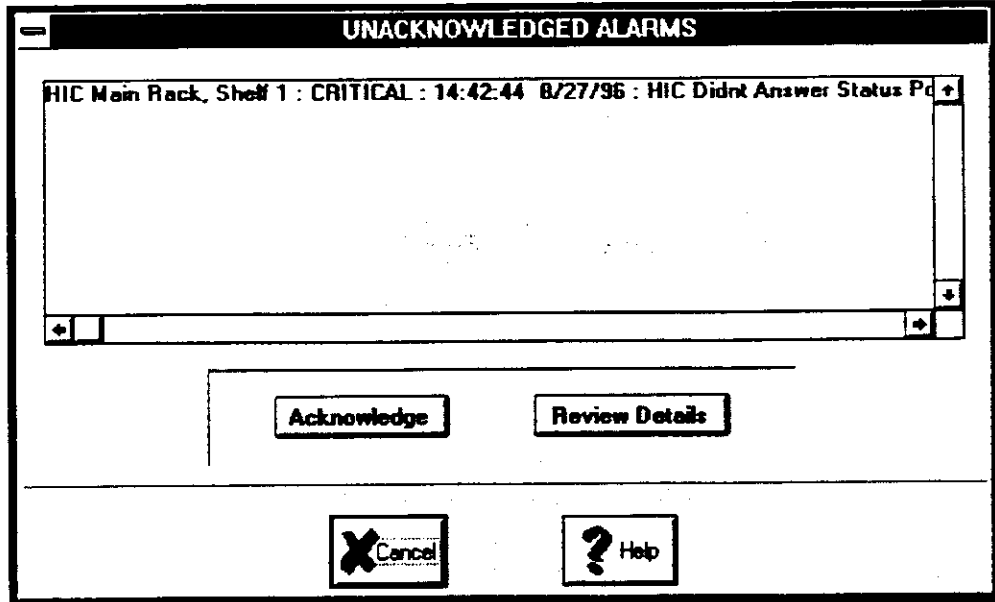

Figure 3-23. UNACKNOWLEDGED ALARMS Dialog

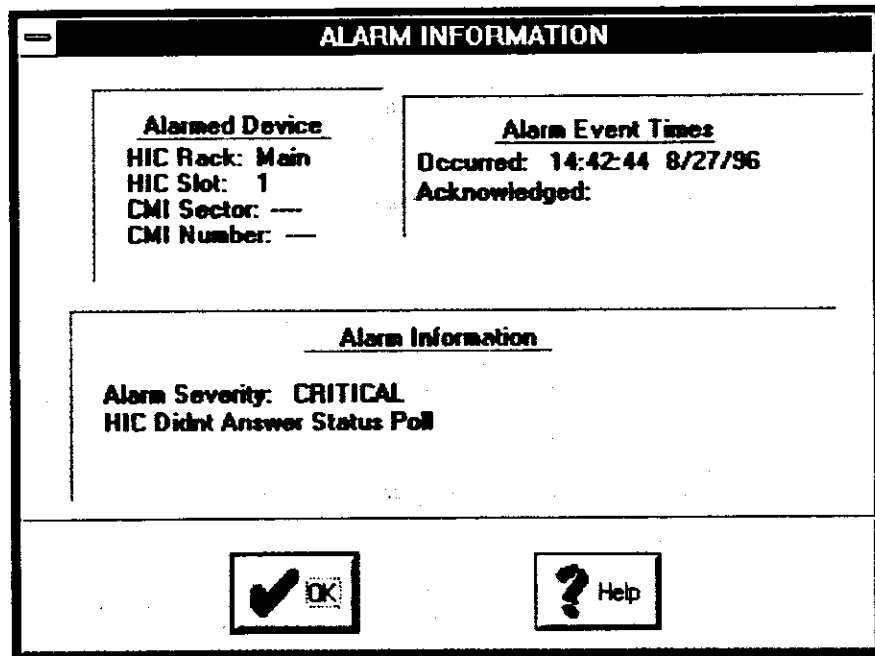

Figure 3-24. Typical ALARM INFORMATION Message

3.3.8.2 Open Alarms

The OPEN ALARMS dialog is shown in Figure 3-25. Select Review Details to display the ALARM INFORMATION message window for the selected alarm. Select Close to remove the selected alarm(s) from the list, indicating to the HECU that the problem causing the alarm has been resolved. Note that the Super-User or authorized User can close an alarm even though the condition causing the alarm may still exist. In such case, a new alarm would be generated the next time the device in question is polled.

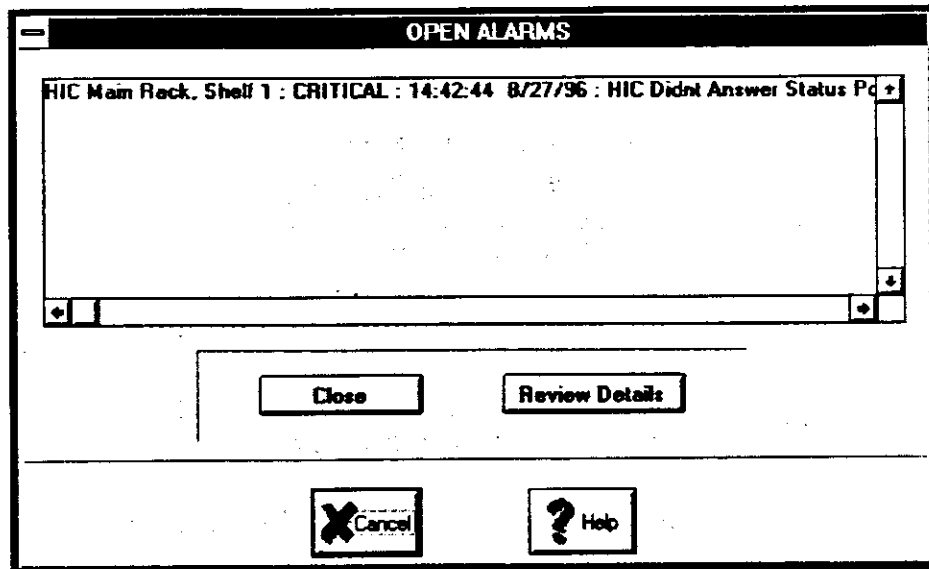

Figure 3-25. OPEN ALARMS Dialog

3.3.8.3 View Alarm Log

A typical ALARM HISTORY message window is shown in Figure 3-26. This message window allows the authorized operator to view the current contents of the alarm log. When the alarm log capacity of 1000 records is reached, the oldest records are deleted.

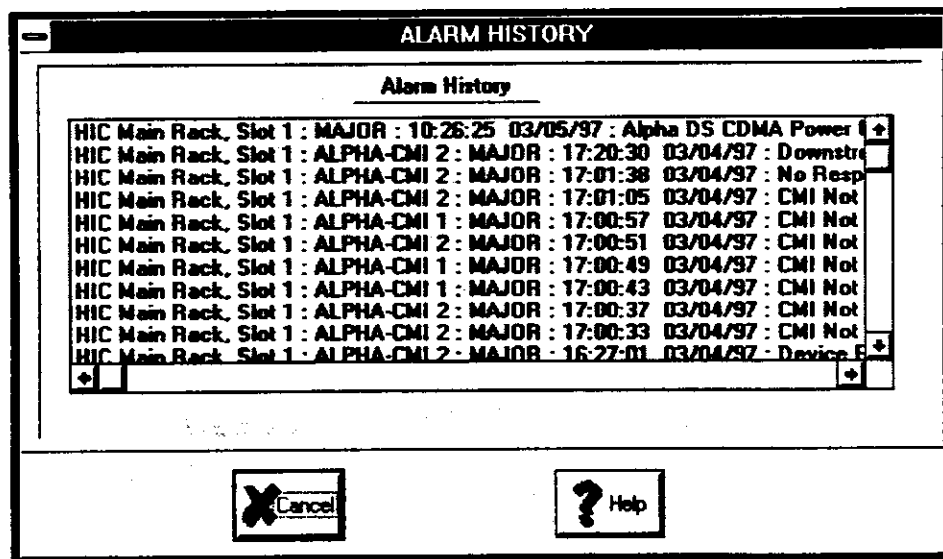

Figure 3-26. ALARM HISTORY Message

3.3.8.4 CMI Out of Service Alarms

The CMI OUT OF SERVICE dialog is shown in Figure 3-27. A CMI Out of Service alarm is generated under one or more of the following conditions:

- 1) If the HECU detects that the user has disabled DS Autogain, US Autogain, Autostats, Primary Rx, Diversity Rx, or the Power Amp.
- 2) If the HIC detects that the Primary Rx, Diversity Rx, or the Power Amp have been disabled, or that the Power Amp output power is less than 23 dBm (continuously monitored by the autostats function).
- 3) If the autogain validation routine detects that autogain cannot be performed (e.g., the condition of a particular CMI is such that autogain will not work).

When a CMI Out of Service alarm is received by the HECU, the affected icon changes color to MAGENTA. The alarm priority is between that of a minor alarm and a major alarm. The alarm is logged like major and minor CMI alarms and is sent to the NOCC. Like all other alarms, it must be manually closed in the OPEN ALARMS dialog. Note that, unlike other alarms, an alarm caused by an out of service condition cannot be cleared from the OPEN ALARMS dialog until the condition causing the alarm has been corrected.

The Super-User may select which conditions to monitor for out of service. All conditions except autostats may be deselected. The dialog also includes a control button for turning the Out of Service Indicator off, necessary for upstream setpoint initialization (see paragraph 3.4.1).

NOTE

Whenever disabling the CMI Out of Service Indicator for maintenance, remember to re-enable it when finished.

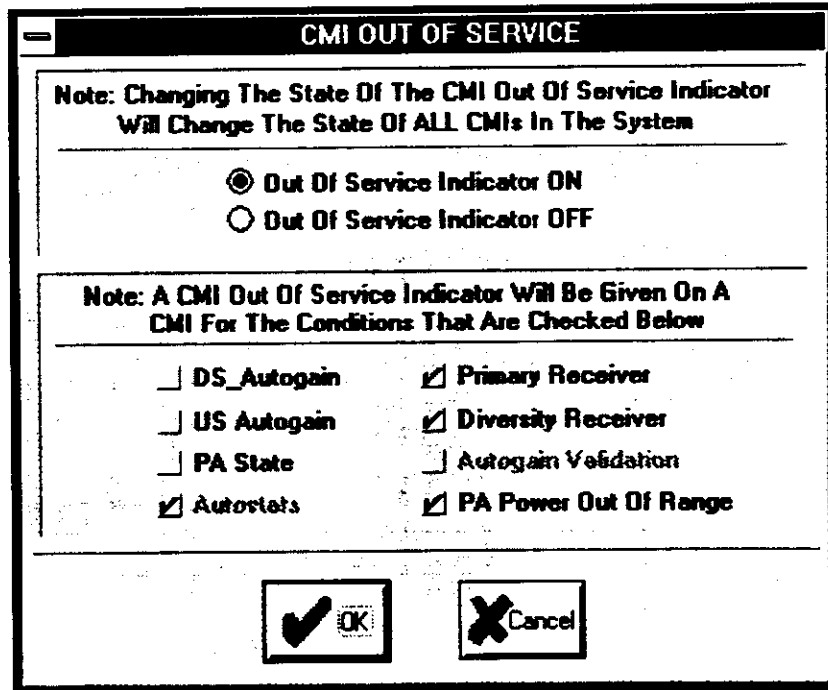

Figure 3-27. CMI OUT OF SERVICE Dialog

3.3.9 Polling Menu Commands

The **Polling** command has a pull-down menu with two choices, **Set Polling Interval** and **Status Polling Interval**.

3.3.9.1 Set Polling Interval

Selecting **Polling/Set Polling Interval** displays the POLLING INTERVAL dialog (Figure 3-28). The time period between successive checks by the HECU for HIC status (polling interval) can be set anywhere from 30 seconds to 5 minutes 30 seconds, in 30-second intervals, using the Minutes and Seconds buttons. The default value is 30 seconds.

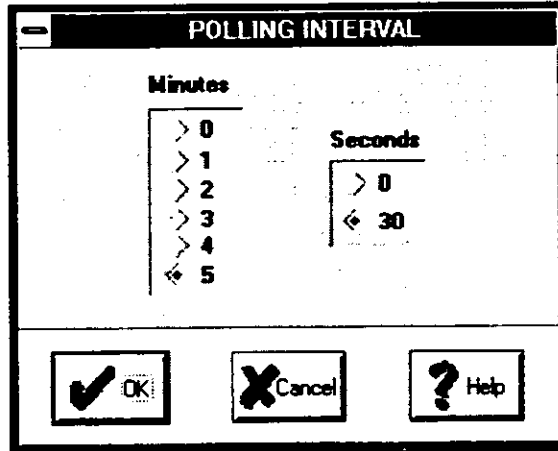

Figure 3-28. POLLING INTERVAL Dialog

3.3.9.2 Status Polling Interval

Selecting **Polling/Status Polling Interval** displays the STATUS POLLING CONTROL dialog (Figure 3-29). This dialog allows a choice of polling all or none of the active devices. The default state is Poll All Devices.

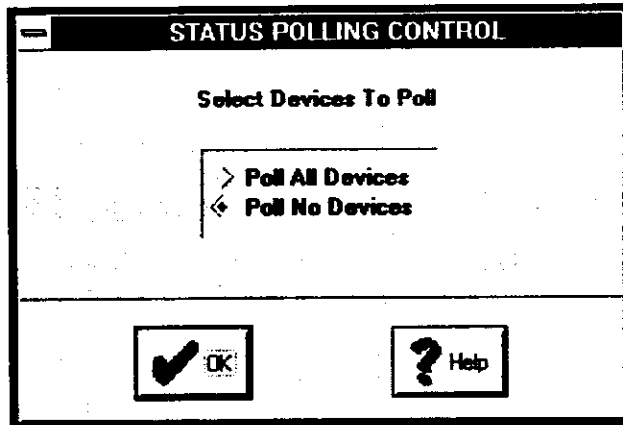

Figure 3-29. STATUS POLLING CONTROL Dialog

3.3.10 Display Menu Commands

The **Display** pull-down menu permits the operator to show or hide the Expansion rack and to show or hide the command toolbar on the HEADEND CONTROL PANEL dialog.

3.3.10.1 Show/Hide Expansion Rack

An expansion rack is represented on the right side of the HEADEND CONTROL PANEL dialog when **Display/Show Expansion Rack** is selected. The expansion rack is removed from display by selecting **Display/Hide Expansion Rack**.

3.3.10.2 Show/Hide Toolbar on Startup

A command toolbar is available for users who prefer working from icons rather than command menus. To display the toolbar, select **Display/Show Toolbar**. The toolbar shown in Figure 3-30 will be displayed. The description for each icon appears at the bottom of the display when the cursor is positioned over any part of the icon. To hide the toolbar, select **Display/Hide Toolbar**.



Figure 3-30. HEADEND CONTROL PANEL: Toolbar

3.3.11 Help Menu Commands

The **Help** pull-down menu permits the operator to select and view the HECU DEVICE COLOR CODES dialog and the ABOUT HECU SOFTWARE message.

3.3.11.1 HECU Device Color Codes

Figure 3-31 shows the device color codes:

Device # (gray):	No Device Present
Device # (green):	Device active with no alarms
Device # (red):	Critical Alarm, a failure that affects loss of many subscribers; e.g., no response from a HIC
Device # (orange):	Major Alarm, a failure that causes loss of service to a small number of subscribers; e.g., no response from a CMI
Device # (magenta):	Out of Service Alarm, a failure that may affect subscribers; e.g., an autogain validation check failure will cause an out-of-service alarm.
Device # (blue):	Minor Alarm, a failure that does not immediately, directly affect subscribers; e.g., a CMI upstream temperature warning
Device # (yellow):	Caution (Managed Device Has Alarm). For example, if a CMI has an alarm, the icon for the HIC that manages that CMI will display in yellow on the HEADEND CONTROL PANEL dialog.

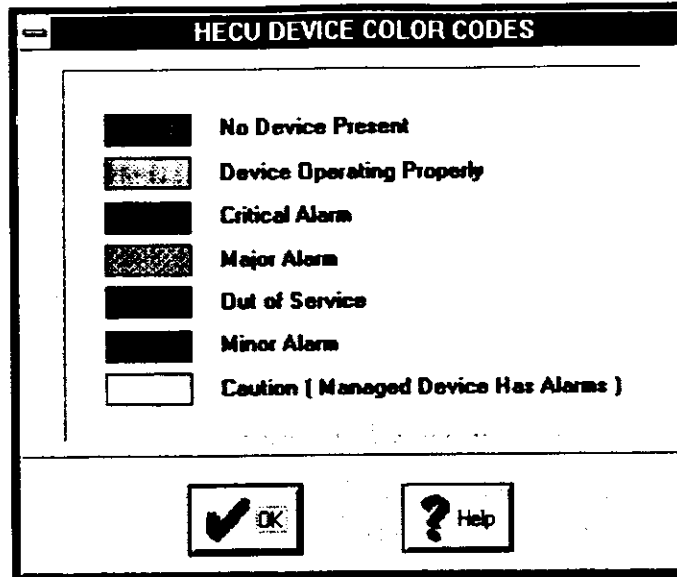

Figure 3-31. HECU DEVICE COLOR CODES Dialog

3.3.11.2 About HECU

Figure 3-32 displays the ABOUT HECU SOFTWARE message window. Text windows are provided for HECU Address, Keyboard ID, CPU ID, and Monitor ID. To add or change text in any of these windows, first select the Change Values button. The data in these windows is not required for HECU monitoring and control, but after Change Values is selected, if nothing is entered in a given window, a NO STRING ENTERED message is displayed (see Figure 3-33). The dialog is cleared by cleared by selecting No.

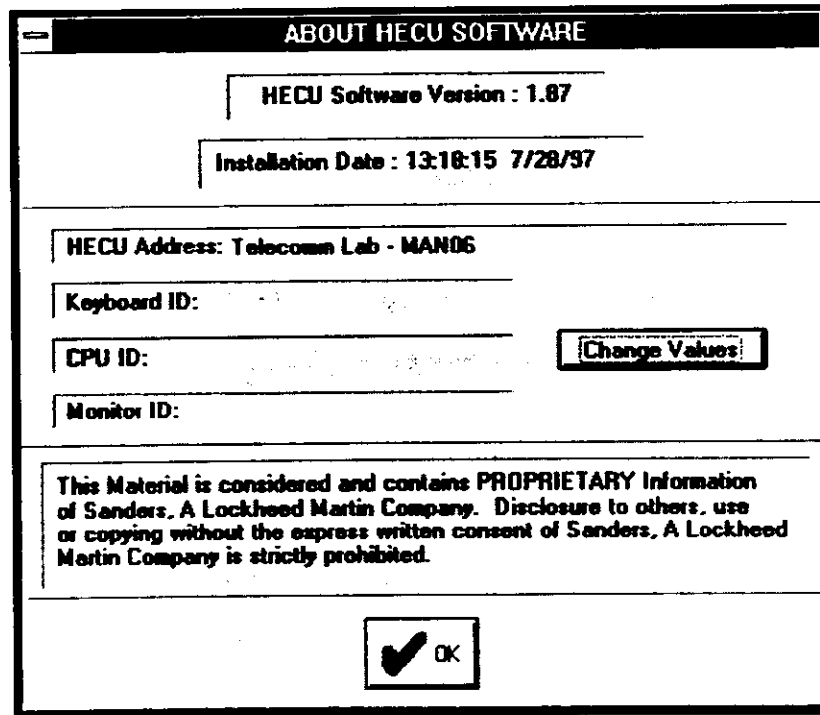

Figure 3-32. ABOUT HECU SOFTWARE Message

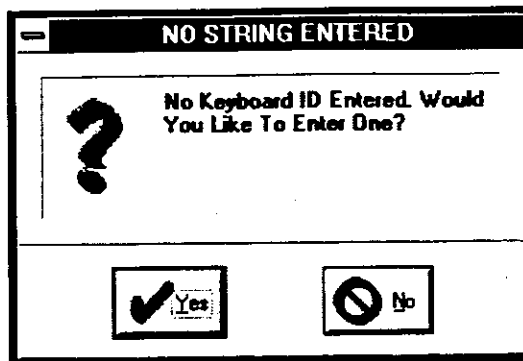

Figure 3-33. Typical NO STRING ENTERED Dialog

3.3.12 Shutting Down the HECU Software Program

Shutting down the HECU monitoring and control software is similar to exiting from most other Windows™-based programs. Any of the following will initiate the software shutdown routine, causing the display of the SHUTDOWN ??? dialog shown in Figure 3-34:

- Double-clicking on the control box in the upper left corner of the HEADEND CONTROL PANEL dialog
- Pressing the [ALT][F4] key combination
- Invoking the Windows™ Task Manager ([CONTROL][ESCAPE] key combination)
- Pressing the [ESCAPE] key from the HEADEND CONTROL PANEL

Shutting down the HECU software has no effect on the call-handling operation of the HICs and CMIs connected to the HECU, only on the ability to monitor and control these devices. Whenever shutting down the HECU, consider the desired state to which the attached devices are to be restored when the HECU software is restarted (paragraph 3.2):

- If the desired restoration state for the HICs and CMIs is the same as their present state, the operator should execute a **Configuration/Save** from the menu bar (paragraph 3.3.6) before shutting down.
- If the desired restoration state for the HICs and CMIs is already saved, the operator may shut down without saving the current configuration. However, when the chosen pre-existing configuration is restored (paragraph 3.2.1), the Reinitialize option must be used (paragraph 3.2.3) to ensure that all settings are returned to the saved configuration.

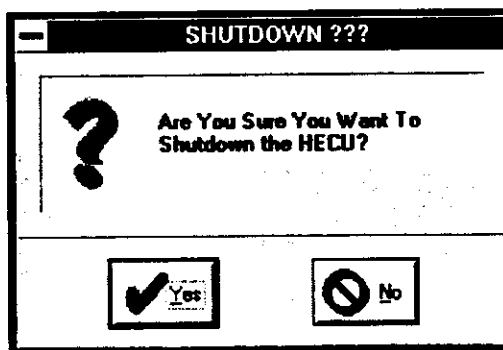

Figure 3-34. SHUTDOWN ??? Dialog

3.4 HIC DIALOGS

3.4.1 HIC CONTROL PANEL Dialog

Figure 3-35 shows a typical HIC CONTROL PANEL dialog. Table 3-4 lists the control and indicator areas of the dialog as they are indexed in the figure and describes their function. The descriptions include references to further dialogs that enable the operator to control and monitor the performance of each installed HIC. The dialog title bar will read HIC CONTROL PANEL: PRIMARY RACK, HIC [n] for the primary rack and HIC CONTROL PANEL: EXPANSION RACK, HIC [n] for the expansion rack. The variable [n] represents the HIC number. The title bar also shows the number of HECU-to-HIC messages waiting to be executed (queued). For discussion purposes, this dialog will be referred to as the HIC CONTROL PANEL dialog.

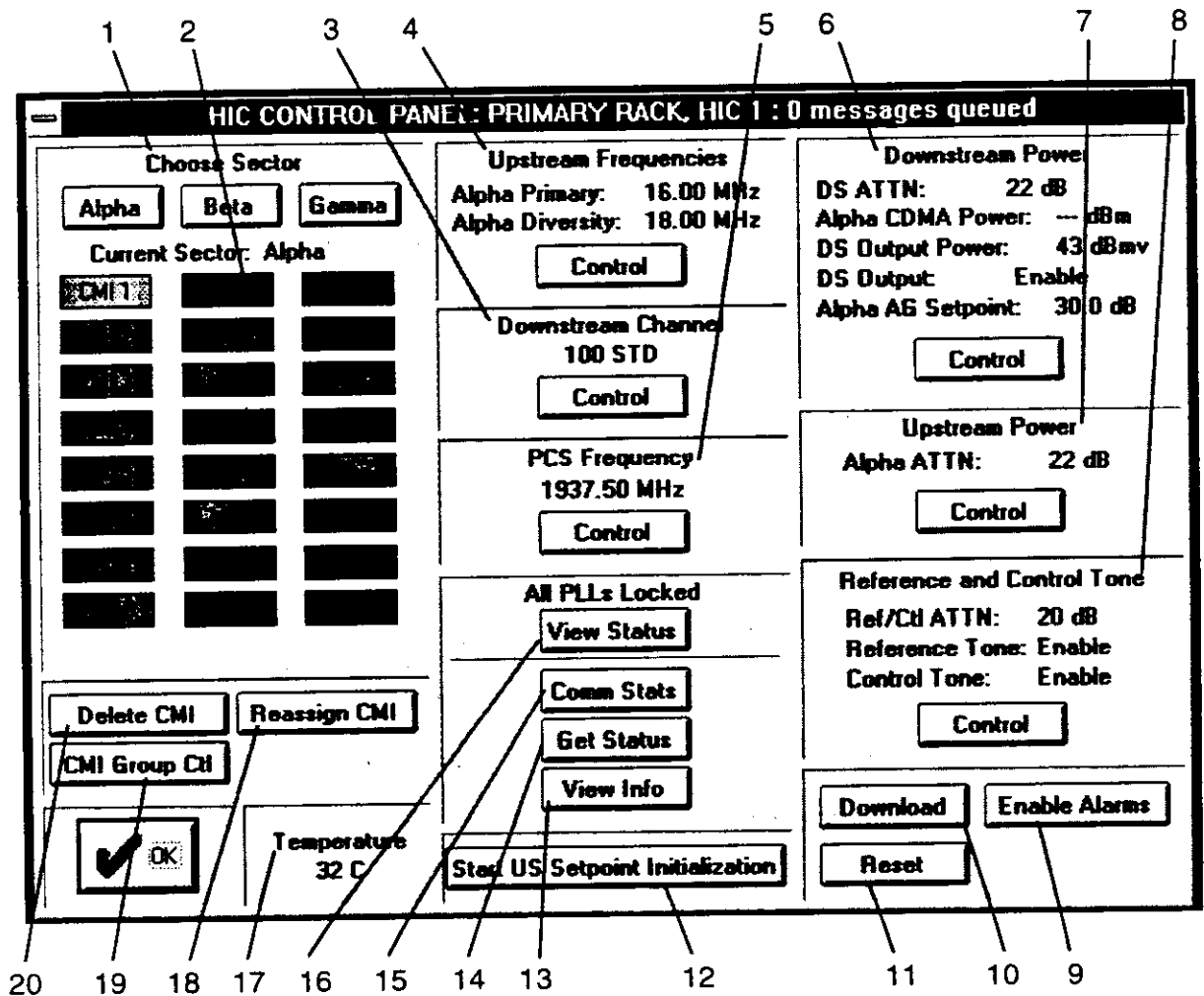

Figure 3-35. Typical HIC CONTROL PANEL dialog

Table 3-4. HIC CONTROL PANEL dialog Functions

Item	Control/Indicator	Function
1	Choose Sector	Select Alpha, Beta, or Gamma to display the corresponding sector.
2	CMI 1–CMI 24	Color coded icons provide equipment status for each CMI in the selected sector; color coding same as for HIC icons (see paragraph 3.3.11.1). Double-click to display ADD CMI dialog (3.4.2) for a non-active CMI, or CMI CONTROL PANEL dialog (paragraph 3.5) for an active CMI.
3	Downstream Channel	Shows current downstream channel and carrier mode for selected sector; select <u>Control</u> to display DOWNSTREAM CHANNEL dialog (paragraph 3.4.10).
4	Upstream Frequencies	Shows current upstream frequencies; select <u>Control</u> to display UPSTREAM FREQUENCY dialog (paragraph 3.4.4).
5	PCS Frequency	Shows current PCS frequency for the Current Sector; select <u>Control</u> to display PCS FREQUENCY dialog (paragraph 3.4.5).
6	Downstream Power	Shows the input CDMA power from the BTS for the selected sector: Display range is -8 to +5 dBm; dashes are displayed for levels \leq -9 dBm. Shows HIC output power to cable plant (combined CDMA, reference and control tones): Display range is +35 to +57 dBmV; dashes are displayed for levels \leq +34 dBmV. Also shows attenuation, output status for the HIC, and the autogain setpoint for the selected sector. Select <u>Control</u> to display HIC DOWNSTREAM POWER dialog (paragraph 3.4.9).
7	Upstream Power	Shows current upstream power attenuator setting for the Current Sector. Select <u>Control</u> to display HIC UPSTREAM POWER dialog (paragraph 3.4.3).
8	Reference and Control Tone	Shows current status and attenuator setting for the HIC; select <u>Control</u> to display REFERENCE AND CONTROL TONE dialog (paragraph 3.4.11).
9	Enable Alarms	Select to display HIC ALARMS ENABLE/DISABLE dialog (paragraph 3.4.16).
10	Download	Select to display CODE DOWNLOAD CONTROL dialog (paragraph 3.4.12).
11	Reset	Select to display HIC RESET CONTROL dialog (paragraph 3.4.13).
12	Start US Setpoint Initialization	Select to start the process of initializing reverse link (upstream) autogain setpoints for a given HIC with respect to its attached CMIs (see paragraph 3.5.1). When this control is selected, it will change to read <u>Stop US Setpoint Initialization</u> .
13	View Info	Select to display HIC ADMINISTRATIVE DATA dialog (paragraph 3.4.6).
14	Get Status	Updates status blocks in this dialog (note that if the message queue is long, there may be a delay of several seconds before the status is updated).
15	Comm Stats	Select to display HIC COMMUNICATIONS STATISTICS dialog (paragraph 3.4.7).
16	View Status	Shows number of unlocked HIC/Converter Phase Locked Loops (PLLs). Click to see HIC PLL STATUS dialog (paragraph 3.4.8).
17	Temperature	Shows current HIC temperature.
18	Reassign CMI	Select to display REASSIGN CMI dialog (paragraph 3.4.14).
19	CMI Group Ctl	Select to display CMI GROUP CONTROL dialog (paragraph 3.4.17).
20	Delete CMI	Select to display DELETE CONTROL dialog (paragraph 3.4.15).

NOTE

A power level displayed as three dashes (- - -) indicates that the power level is too low for the system to read reliably.

3.4.2 ADD CMI Dialog

A new CMI can be added to the HECU monitoring and control routine by double-clicking any inactive (gray) CMI location from the HIC CONTROL PANEL dialog. Figure 3-36 shows an example of the resulting Add CMI: dialog. The Add CMI dialog allows various CMI default parameters to be changed. Table 3-5 describes the function of each control and indicator in this dialog, and Section 4 contains information on how the dialog is used in operating procedures. The dialog title bar will read ADD CMI: [s] SECTOR, where [s] represents the sector selected. For discussion purposes, this dialog will be referred to as the ADD CMI dialog.

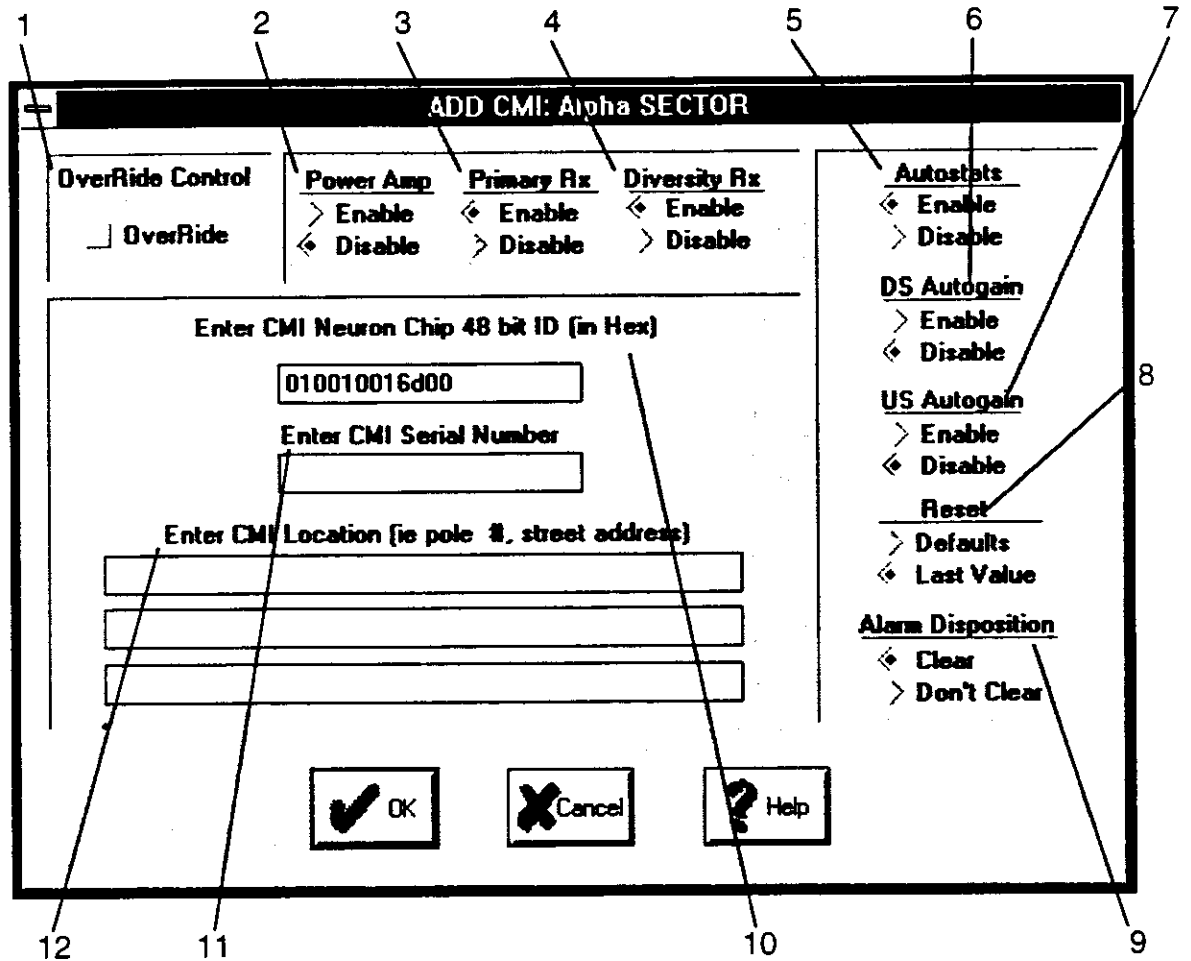

Figure 3-36. Typical ADD CMI Dialog

Table 3-5. ADD CMI Dialog Functions

Item	Control/Indicator	Function
1	Override Control	Selected when there is a communication problem with the CMI being added. Should be used only when troubleshooting: <u>Case 1</u> - CMI is known to be active but cannot be acquired in a normal manner. If HIC-to-CMI communication is working, it may be possible to reset CMI to Defaults and re-establish normal communication. <u>Case 2</u> - Problem occurs during Code Download such that CMI hangs up. It may be possible to delete CMI, reacquire with Override selected, and start download process again.
2	Power Amp	Buttons to enable/disable the power output. (<u>Disable</u> permits off-line installation testing.)
3	Primary Rx	Buttons to enable/disable the primary receiver (<u>Disable</u> permits off-line installation testing.)
4	Diversity Rx	Buttons to enable/disable the diversity receiver. (<u>Disable</u> permits off-line installation testing.)
5	Autostats	Buttons to enable/disable autostatistics. <u>Enable</u> is default.
6	DS Autogain	Buttons to enable/disable downstream autogain. <u>Disable</u> is default.
7	US Autogain	Buttons to enable/disable upstream autogain. <u>Disable</u> is default.
8	Reset	Buttons to set the mode in which the CMI will reset on a subsequent Power Up - Reset command. Defaults to <u>Last Values</u> .
9	Alarm Disposition	Allows operator to select whether or not to clear old alarms. <u>Clear</u> is default.
10	Enter CMI Neuron Chip 48 bit ID (in Hex)	Data entry box for Neuron® chip identification number of the CMI being added, in hexadecimal format: This number <u>must</u> be entered to activate the CMI.
11	Enter CMI Serial Number	Data entry box for serial number of CMI being added. This data is optional but it is recommended as it will appear in various status windows.
12	Enter CMI Location(i.e. pole #, street address)	Data entry boxes for entering physical location of added CMI. This data is optional but recommended.

3.4.3 HIC Upstream Power Control

The HIC UPSTREAM POWER dialog (Figure 3-37) permits the operator to set the upstream power control in the alpha, beta, and gamma sectors. Parameters are set in each sector as follows:

- *Upstream Attenuator Setting* - Allows manual setting of upstream power control attenuation value between 0–44 dB in 2-dB steps. This controls the output level of the HIC to the BTS input.
- *Ingress Threshold* - Allows manual setting of the maximum acceptable ingress noise level. The default setting is 3.0 dB.
- *Save to Flash* - Selection of this button stores settings in flash memory.

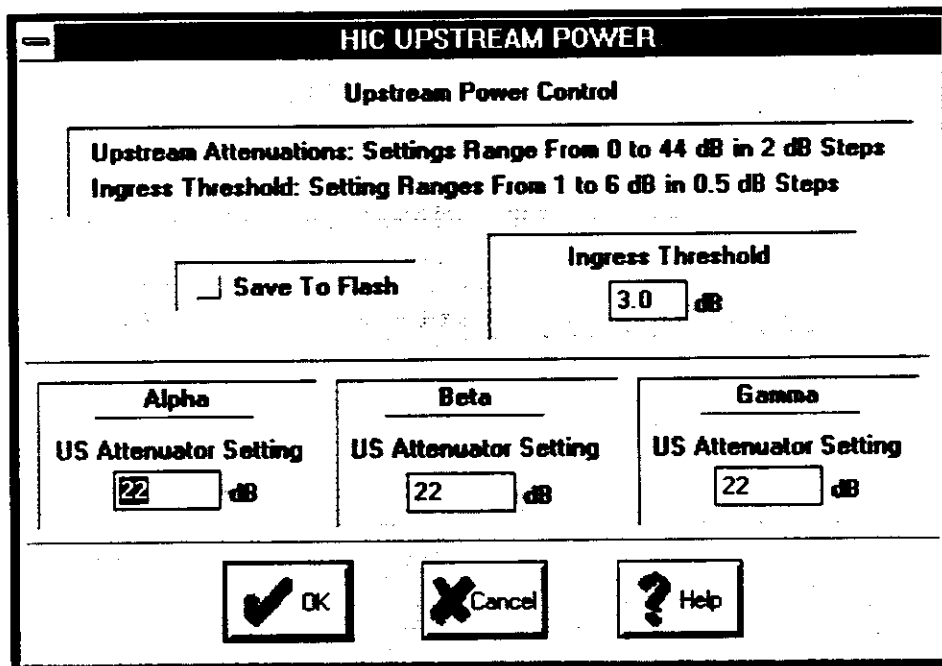

Figure 3-37. HIC UPSTREAM POWER Dialog

3.4.4 HIC Upstream Frequency Control

The UPSTREAM FREQUENCY dialog (Figure 3-38) permits the operator to set the upstream channel for primary and diversity frequency values in the alpha, beta, and gamma sectors. Parameters are set in each sector as follows:

- *Primary Frequency* - Allows manual setting of upstream primary channel frequency between 6 and 41 MHz in 0.25-MHz steps.
- *Diversity Frequency* - Allows manual setting of upstream primary channel frequency between 6 and 41 MHz in 0.25-MHz steps.

NOTE

For proper system operation, each Primary frequency must be set at least 2 MHz away from (normally below), and not greater than 4.75 MHz away from, the related Diversity frequency.

UPSTREAM FREQUENCY CONTROL PANEL		
NOTE: All Frequency Values Range From 6 - 41 MHz in 0.25 MHz Steps		
Alpha Sector	Beta Sector	Gamma Sector
Primary Frequency 16.00 MHz	Primary Frequency 20.00 MHz	Primary Frequency 24.00 MHz
Diversity Frequency 18.00 MHz	Diversity Frequency 22.00 MHz	Diversity Frequency 26.00 MHz
<input checked="" type="checkbox"/> OK	<input type="checkbox"/> Cancel	<input type="checkbox"/> Help

Figure 3-38. UPSTREAM FREQUENCY Dialog

3.4.5 HIC PCS Frequency Control

The PCS FREQUENCY dialog (Figure 3-39) permits a user to set the PCS channel, either in megahertz or by channel number.

- *Enter PCS Frequency* - Data entry box for the desired frequency between 1930 and 1945 MHz, or the desired PCS channel.
- *Entry Options* - Buttons allow operator to enter frequency or channel.

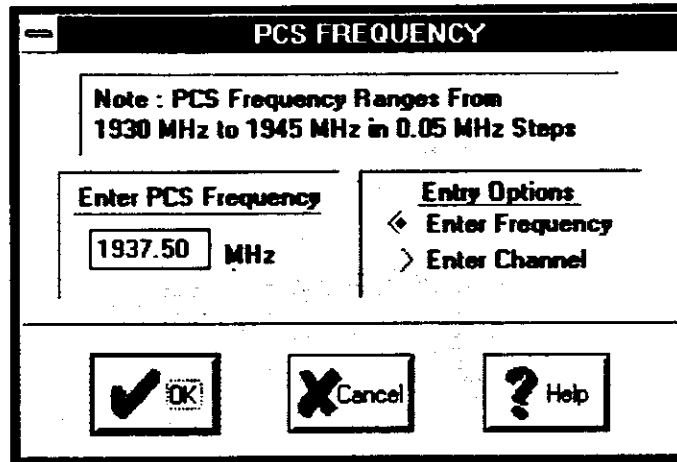
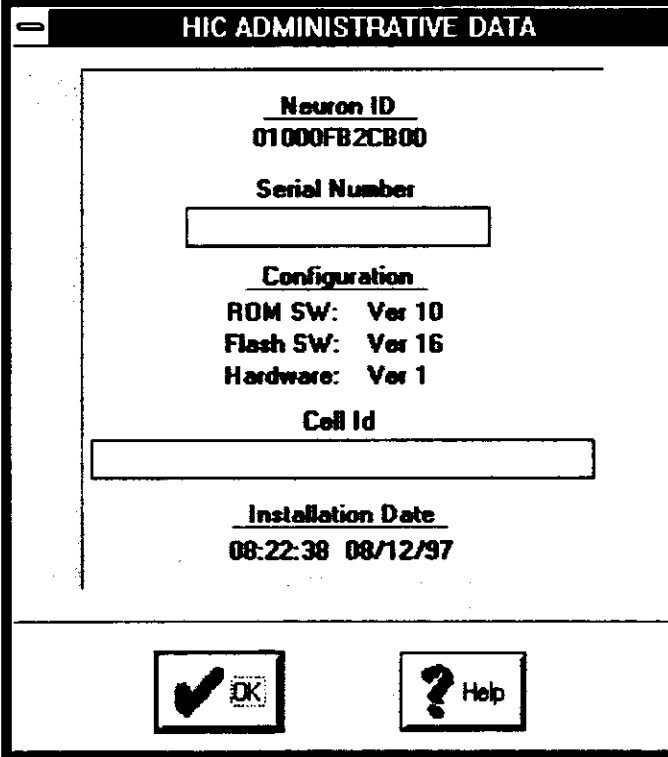

Figure 3-39. PCS FREQUENCY Dialog

3.4.6 HIC Administrative Data

The HIC ADMINISTRATIVE DATA message window (Figure 3-40) is displayed by selecting the View Info button at the HIC CONTROL PANEL dialog. It permits the operator to view the data that was entered when the selected HIC was added (see paragraph 3.3.2) and to enter additional reference data.

- *Neuron ID* - Neuron® chip identification number in hexadecimal format
- *Serial Number* - HIC serial number identification may be entered here
- *Configuration* - Displays current versions of:
 - ROM software (SW)
 - EEPROM software
 - Hardware
- *Cell ID* - Assigned cell identification number may be entered here
- *Installation Date* - HIC installation date



HIC ADMINISTRATIVE DATA

Neuron ID
01000FB2CB00

Serial Number
[Empty Input Field]

Configuration
ROM SW: Ver 10
Flash SW: Ver 16
Hardware: Ver 1

Cell Id
[Empty Input Field]

Installation Date
08:22:38 08/12/97

[OK] [Help]

Figure 3-40. HIC ADMINISTRATIVE DATA Message

3.4.7 HIC Communications Statistics

The HIC COMMUNICATIONS STATISTICS dialog (Figure 3-41) displays the communications statistics between the selected HIC and all of its CMIs. Two columns are displayed, Total and Delta. The Total column indicates the number of events since the last Clear Stats selection, the Delta column indicates the number of events since the last time that Update Stats was selected. (Note that all counters roll over at 65536.)

- *Messages Processed* - Number of times HIC poll responses have been received within specified time.
- *Neuron Timeouts* - Number of times a poll response has not been received from selected HIC within timeout period (usually indicates upstream problems).
- *Demodulator Timeouts* - Number of times upstream data from selected HIC has not been correctly demodulated (usually indicates downstream problems).
- Update Stats - When selected, this button updates the displayed numbers.
- Clear Stats - When selected, this button clears displayed numbers from both columns and restarts the counters.

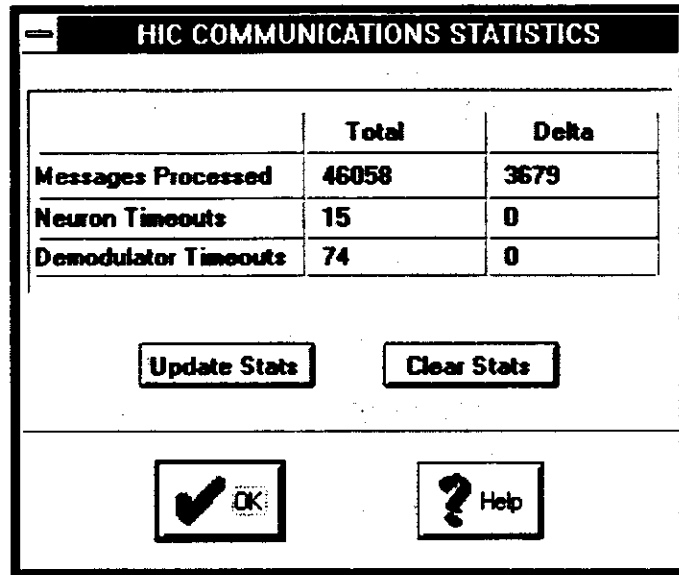

Figure 3-41. HIC COMMUNICATIONS STATISTICS Dialog

3.4.8 HIC PLL Status Display

The HIC PLL STATUS message window (Figure 3-42) Identifies any of the HIC's 16 Phase Locked Loops (PLLs) that are in an unlocked (failed) condition. In normal operation, the status window contains a statement that all phase-locked loops are locked.

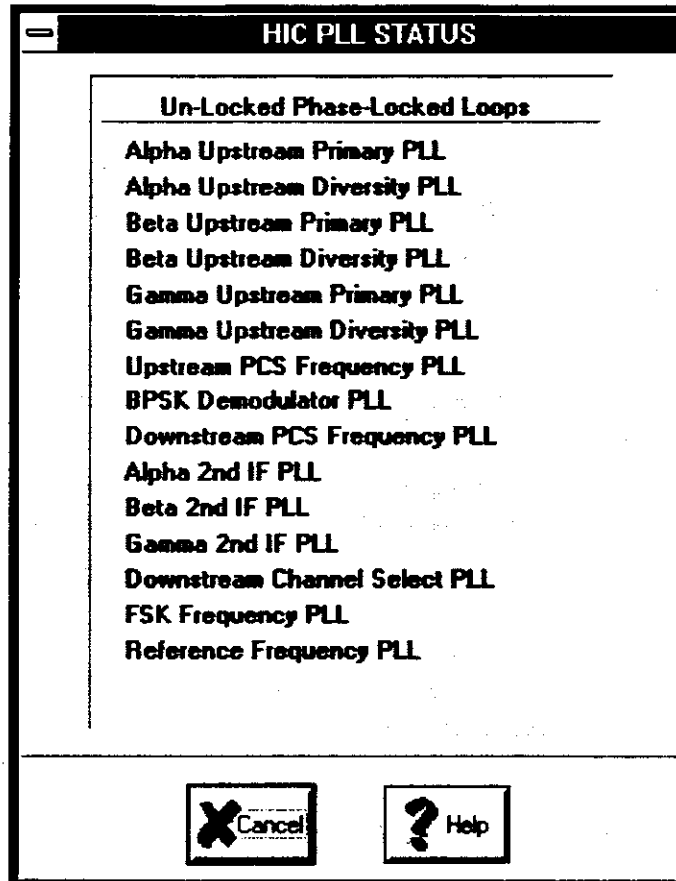

Figure 3-42. HIC PLL STATUS Message

3.4.9 HIC Downstream Power Control

The HIC DOWNSTREAM POWER dialog (Figure 3-43) permits the operator to set the downstream attenuation.

- *Save to Flash* - When selected, downstream power settings are saved in flash memory
- *Power Output* - Allows operator to enable/disable the power output.
- *DS Autogain Set Points* - Allows the operator to adjust the downstream autogain level (the gain from the HIC input to the CMI power amplifier output) for each sector between 22.0 and 38.0 dB in 0.5-dB steps. The default value is 30.0 dB.
- *DS Attenuator Setting* - Allows manual setting of attenuation between 0 and 44 dB in 2-dB steps. This attenuator controls the level of downstream CDMA power from the HIC to the cable plant. The default value is 22 dB.

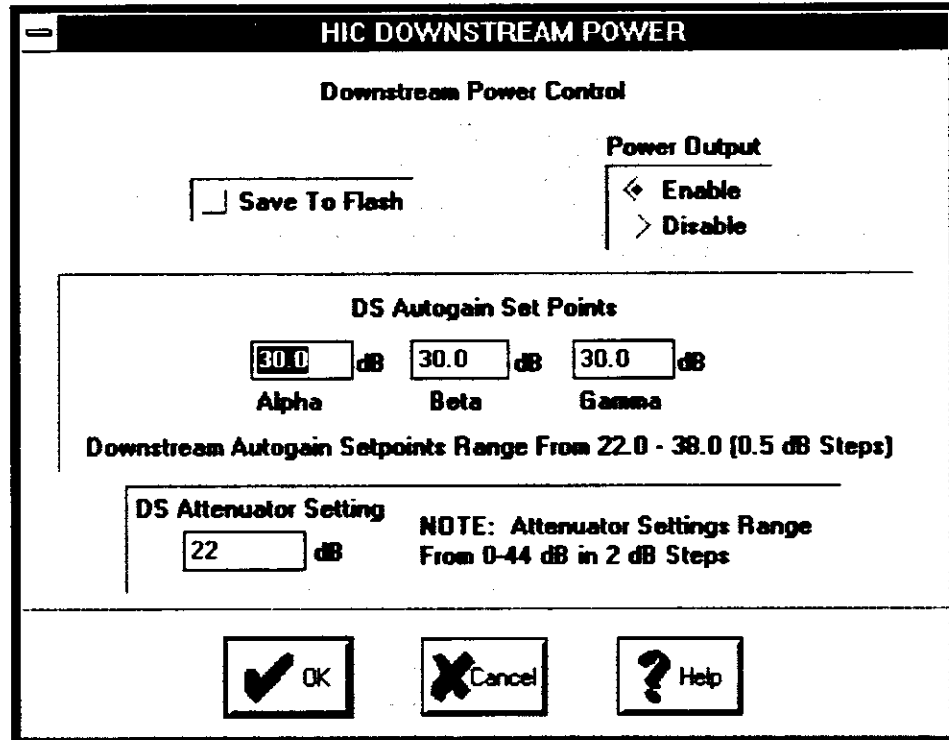

Figure 3-43. HIC DOWNSTREAM POWER Dialog

3.4.10 HIC Downstream Channel Control

The DOWNSTREAM CHANNEL dialog (Figure 3-44) permits the operator to set the downstream channel value.

- *Enter New Downstream Channel Value* - Allows operator to set channel range between 62-94 and 100-116.
- *Channel Type* - Allows operator to select carrier type: STD (standard), HRC (harmonic related carrier), or IRC (incrementally related carrier).

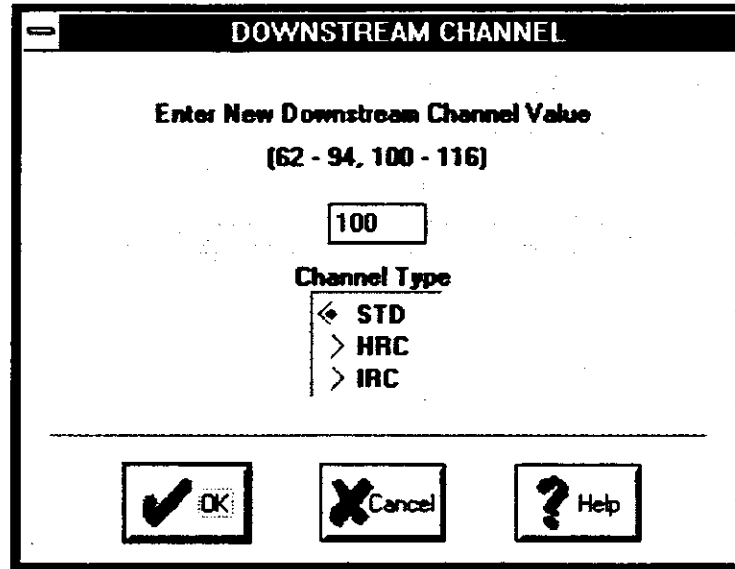

Figure 3-44. DOWNSTREAM CHANNEL Dialog

3.4.11 HIC Reference and Control Tones

The REFERENCE AND CONTROL TONES dialog (Figure 3-45) permits the operator to set the downstream attenuation value.

- *Save to Flash* - When selected, reference and control tone settings are saved in flash memory
- *Reference Tone* - Allows operator to enable/disable reference tone.
- *Control Tone* - Allows operator to enable/disable control tone.
- *Attenuator Setting* - Allows manual operator setting of attenuation between 0–44 dB in 2-dB steps. The attenuator controls the level of both the Reference Tone and the Control Tone in the forward link (to the cable plant). The default attenuator value is 20 dB.

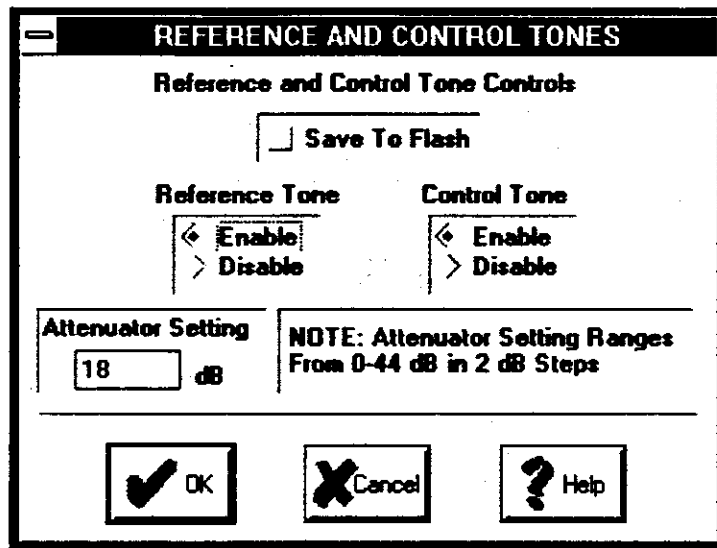

Figure 3-45. REFERENCE AND CONTROL TONES Dialog

3.4.12 Code Download Control

See paragraph 4.6.2 for a complete guide to all Software Download Procedures. The CODE DOWNLOAD CONTROL dialog (Figure 3-46) permits a user to download future HIC and CMI software upgrades. This dialog is displayed by selecting the Download button at the HIC CONTROL PANEL dialog (for HIC code) or the CMI CONTROL PANEL dialog (for CMI code). The file containing the upgraded code is entered in the *Enter Source Code Filename* window. The correct filename for HIC code is HIC_HEC.P, and for CMI code it is CMI.HEX. The filenames are not case sensitive.

NOTE

The operating software expects the files to be located on the hard drive in the **c:\hec\bin** directory. If the file to be downloaded is in any other location, then the full path and file name must be provided.

Upon selecting OK, the operating software first checks the validity of the filename extension. If the filename extension entered does not match the expected one, an error message is displayed. If the filename is valid, the operating software looks for the file; an error message is displayed if the file is not found. When the file is found, it is checked for valid content, and an error message is displayed if the content is invalid.

After passing the above validity checks, the download operation begins, and a message window displays the progress.

CAUTION

Once a HIC or CMI Code Download operation has begun, **it must be completed**. If the Cancel button on the download progress window is selected while download is in progress, the aborted operation will leave the device firmware in a code download (non-communicating) state. Do not delete the device or shut off power to the device until the device has been properly downloaded. To restart a canceled download, select the Download button again.

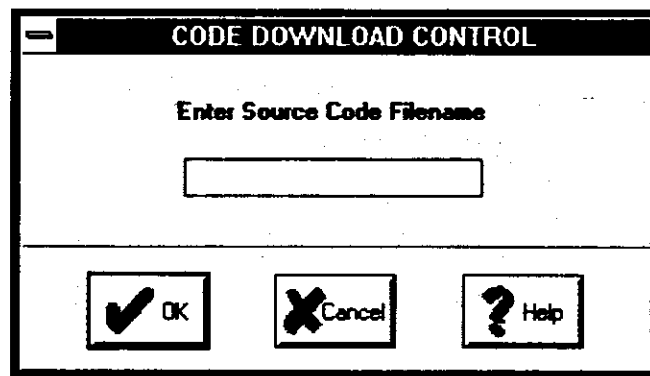

Figure 3-46. CODE DOWNLOAD CONTROL Dialog

3.4.13 HIC Reset Control

The HIC RESET CONTROL dialog (Figure 3-47) permits a user to select between two sets of HIC reset values, and it performs a soft reset when OK is selected. The Defaults button resets to default settings; the Last Value button resets to last values saved. The reset values selected are used after both power-on resets and soft resets. See paragraph 4.8.1 for a list of default values and important procedural information.

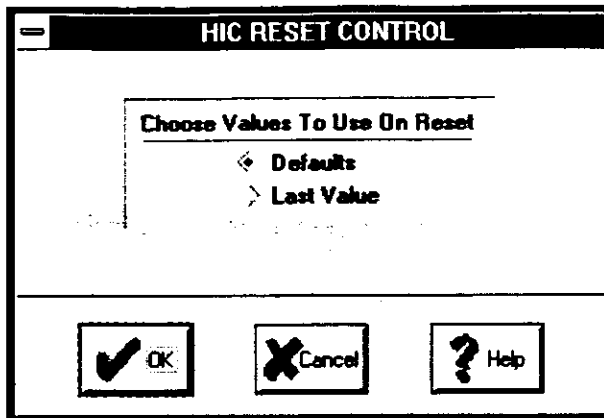

Figure 3-47. HIC RESET CONTROL Dialog

3.4.14 Reassign CMI

The REASSIGNING CMI dialog (Figure 3-48) allows reassignment of the CMI indicated in the title bar to a different sector, either to the same HIC or a different HIC.

- *Destination HIC* - includes rack select buttons and a text window for entering the destination HIC slot for the CMI being reassigned.
- *Destination CMI* - includes Alpha, Beta, and Gamma select buttons and a text window for entering the CMI number (corresponding to the numbers in the CMI icons on the HIC CONTROL PANEL dialog).

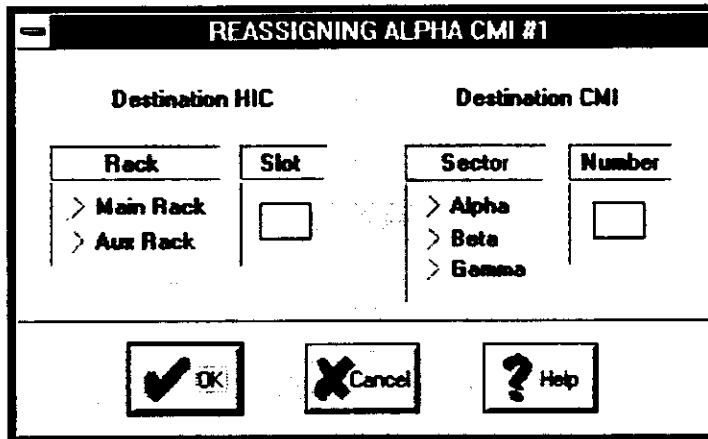

Figure 3-48. REASSIGNING CMI Dialog

3.4.15 Delete Control (CMI)

The DELETE CONTROL dialog shown in Figure 3-49 is displayed when the Delete CMI button is selected at the CMI CONTROL PANEL dialog. The text of the query in the message box will vary to reflect the selected CMI.

- YES - Normal delete mode; requires that the communication link with the selected CMI is operating normally before deactivating the unit. A message window will confirm communication status. If communication is successful, the selected unit is deactivated. If not, the DELETE CONTROL dialog is displayed again.

- NO - Selected only when communication with selected CMI has been lost; the unit is deleted from the HIC immediately without further attempts to communicate with it. The CMI is left in an uncontrolled state; and maintenance action is required.
- CANCEL - ends the display of the dialog.

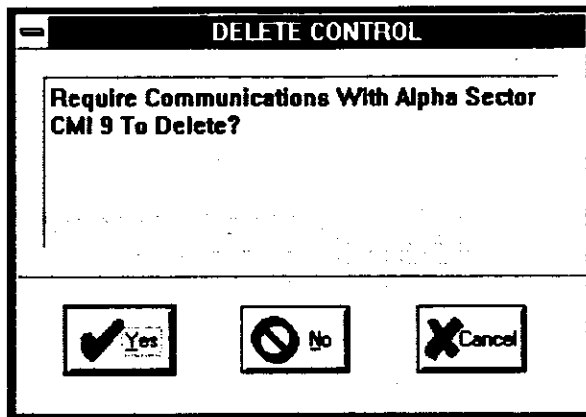

Figure 3-49. Typical DELETE CONTROL Dialog for CMI

3.4.16 HIC Alarms Enable/Disable

The HIC ALARMS ENABLE/DISABLE dialog (Figure 3-50) contains check boxes for specific HIC alarms. When a box is checked, that particular type of alarm is reported. The operator is cued to check for an alarm by the color of the HIC icon on the HEADEND CONTROL PANEL dialog. Alarm details are obtained through the **Alarms** menu (see paragraph 3.3.8).

- *Enable All Alarms* - Selection of the button selects all alarm check boxes.
- *Disable All Alarms* - Selection of the button deselects all alarm check boxes.

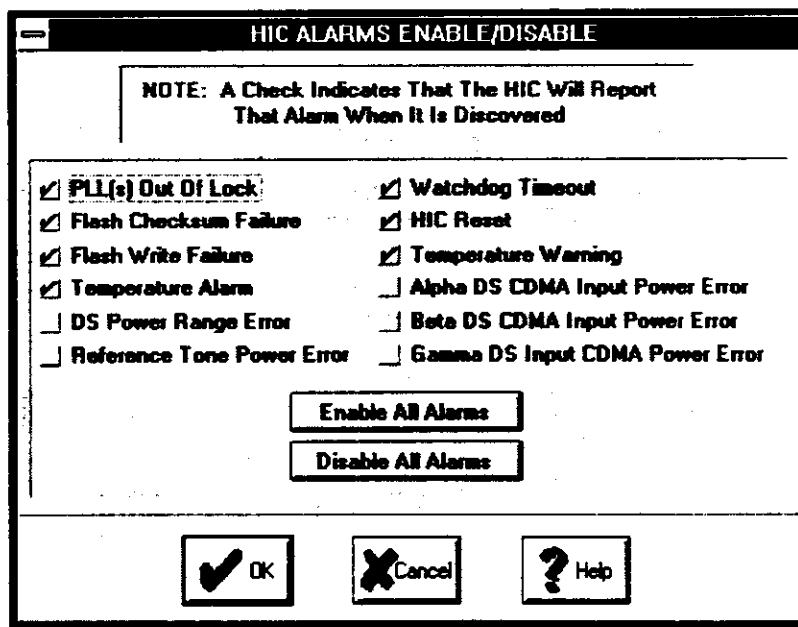

Figure 3-50. HIC ALARMS ENABLE/DISABLE Dialog

NOTE

Reference Tone Power Error alarm is not active in HECU Version 1.87.

3.4.17 CMI Group Control

The **CMI GROUP CONTROL** dialog (Figure 3-51) allows the control of all the CMIs in one, two, or three sectors as a group. Selecting the Don't Set check box excludes that given feature from group control.

- *Autostats* - When enabled, permits the automatic collection of CMI status.
- *DS Autogain* - Enables/disables the downstream autogain function for selected CMI group (power amplifier must be enabled)
- *US Autogain* - Enables/disables the upstream autogain function for selected CMI group (both receivers must be enabled)
- *Choose Sector(s)* - select one or more sectors for group control
- *Power Amp* - When enabled, activates the power amplifiers for the selected CMI group.
- *Primary Rx* - When enabled, activates the primary receivers for the selected CMI group.
- *Diversity Rx* - When enabled, activates the diversity receivers for the selected CMI group.
- *Alarms* - Enables or disables all alarms for the selected CMI group.

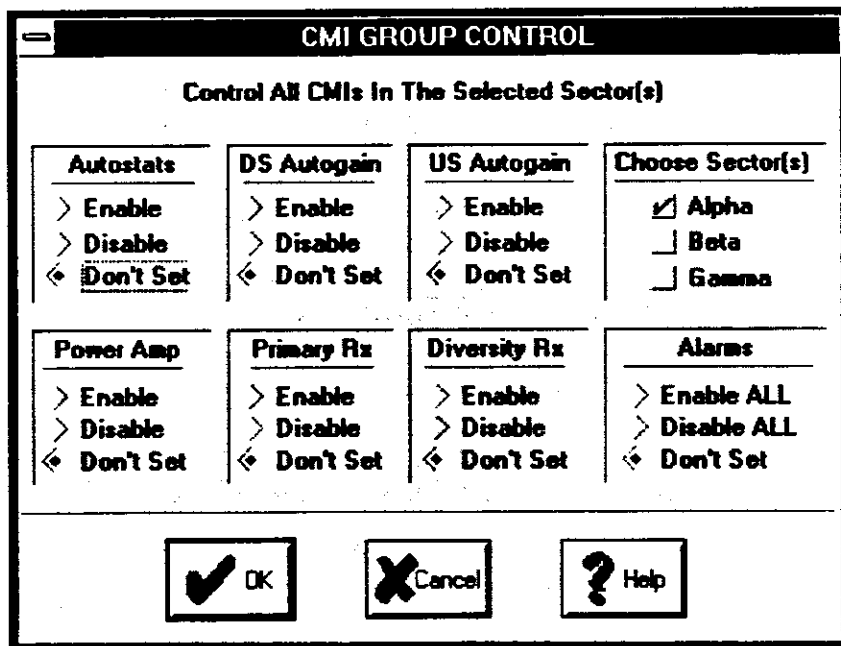

Figure 3-51. CMI GROUP CONTROL Dialog

3.5 CMI DIALOGS

3.5.1 CMI CONTROL PANEL dialog

Figure 3-52 shows a typical CMI CONTROL PANEL dialog. Table 3-6 lists the control and indicator areas as they are indexed in the figure and describes their function. The descriptions include references to further dialogs enable the operator to control and monitor the performance of each installed CMI. The dialog title bar will read CMI CONTROL PANEL: [s] SECTOR, CMI [n], where [s] represents the sector selected and [n] represents the CMI number selected on the HIC CONTROL PANEL dialog. For discussion purposes, this dialog will be referred to as the CMI CONTROL PANEL dialog.

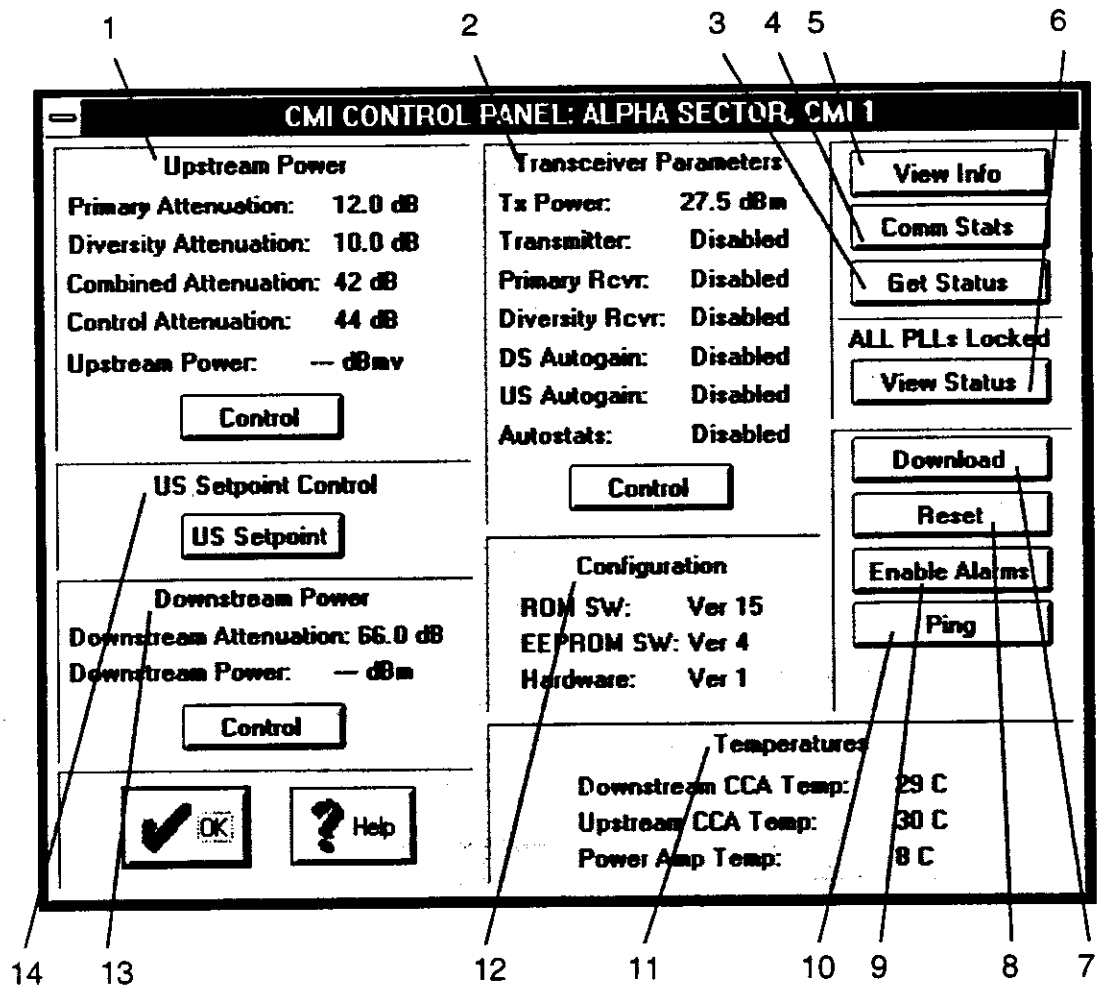

Figure 3-52. Typical CMI CONTROL PANEL dialog

Table 3-6. CMI CONTROL PANEL dialog Functions

Item	Control/Indicator	Function
1	Upstream Power	Shows current upstream levels and attenuator settings: Display range for Upstream Power is +30 to +53 dBmV; dashes are displayed when level is below +30 dBmV. Select <u>Control</u> to display CMI UPSTREAM POWER dialog (paragraph 3.5.2).
2	Transceiver Parameters	Shows current levels and option status; Display range Tx Power is +17 to +37 dBm; dashes are displayed when level is below +17 dBm. Select <u>Control</u> to display TRANSCEIVER CONTROL dialog (paragraph 3.5.4).
3	Get Status	Updates status blocks in this dialog.
4	Comm Stats	Select to see CMI COMMUNICATIONS STATISTICS dialog (paragraph 3.5.6).
5	View Info	Select to see CMI ADMINISTRATIVE DATA dialog (paragraph 3.5.5).
6	View Status	Shows the number of CMI PLLs currently unlocked; select <u>View Status</u> to see CMI PLL STATUS dialog (paragraph 3.5.7).
7	Download	Select to display CODE DOWNLOAD CONTROL dialog (paragraph 3.4.12).
8	Reset	Select to display CMI RESET CONTROL dialog (paragraph 3.5.8).
9	Enable Alarms	Select to display CMI ALARMS ENABLE/DISABLE dialog (paragraph 3.5.9).
10	Ping	Select to display PING CMI dialog (paragraph 3.5.10), used to test reverse link (upstream) continuity for a particular CMI.
11	Temperatures	Displays current CMI temperatures.
12	Configuration	Shows current software (SW) and hardware versions.
13	Downstream Power	Shows current downstream levels: Downstream attenuation is the value of the attenuator losses between the CMI downstream input and the CMI power amplifier stage input. Downstream Power is the CDMA input power into the CMI power amplifier stage, which has a typical gain of 64 dB. Downstream Power displays down to -39 dBm; dashes are displayed for levels below -39 dBm, and an alarm is set if level exceeds -20 dBm. Select <u>Control</u> to display CMI DOWNSTREAM POWER dialog (paragraph 3.5.3).
14	US Setpoint Control	Used in conjunction with <u>Start US Setpoint Initialization</u> control in HIC CONTROL PANEL dialog (see paragraph 3.4.1); select <u>US Setpoint</u> button to display US SETPOINT INITIALIZATION dialog (see paragraph 3.5.11).

NOTE

A power level displayed as three dashes (- - -) indicates that the power level is too low for the system to read reliably.

3.5.2 CMI Upstream Power Control

The CMI UPSTREAM POWER dialog (Figure 3-53) for the CMI permits the operator to set the upstream primary, diversity, combined, and control tone attenuation values.

- *Save to EEPROM* - Selection of this button stores settings in Electrically Erasable Programmable Read-Only Memory.
- *Upstream Primary ATTN* - Allows manual setting of upstream primary attenuation between 0–59.5 dB in 0.5-dB steps. Default is 4.0 dB.
- *Upstream Diversity ATTN* - Allows manual setting of upstream diversity attenuation between 0–59.5 dB in 0.5-dB steps. Default is 4.0 dB.
- *Upstream Combined ATTN* - Allows manual setting of upstream combined attenuation between 30–88 dB in 2-dB steps. Default is 44 dB.
- *Control Tone ATTN* - Allows manual setting of control tone attenuation between 0–44 dB in 2-dB steps. Default is 20 dB.

CMI UPSTREAM POWER

Save To EEPROM

Attenuator Setting Ranges

Primary / Diversity ATTNs: Range From 0 to 59.5 dB in 0.5 dB Steps
Combined Attenuation : Ranges From 30 to 88 dB in 2 dB Steps
Control Tone ATTN : Ranges From 0 to 44 dB in 2 dB Steps

Upstream Primary ATTN 7.5 dB	Upstream Diversity ATTN 9.0 dB
Upstream Combined ATTN 46 dB	Control Tone ATTN 12 dB

OK Cancel Help

Figure 3-53. CMI UPSTREAM POWER Dialog

3.5.3 CMI Downstream Power Control

The CMI DOWNSTREAM POWER dialog (Figure 3-54) permits the operator to set the downstream attenuation value.

- *DS Attenuation* - Allows manual operator setting of downstream attenuation between 0-103.5 dB in 0.5 dB incremental steps. A Reset to Defaults command results in a setting of 54.0 dB.
- *Save to EEPROM* - Selection of this button stores settings in Electrically Erasable Programmable Read-Only Memory.

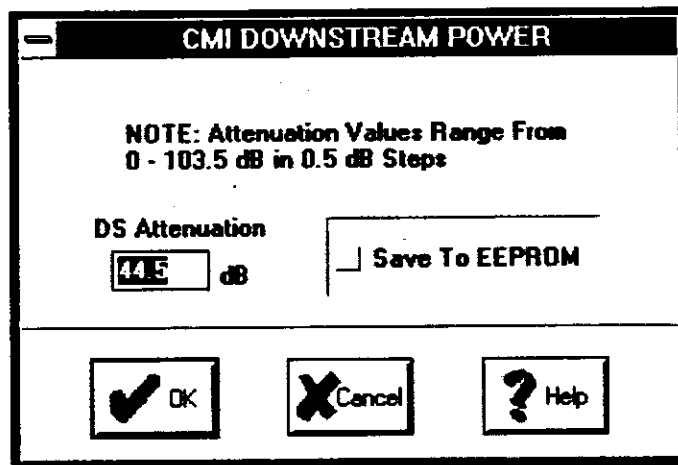

Figure 3-54. CMI DOWNSTREAM POWER Dialog

3.5.4 Transceiver Control Panel

The TRANSCEIVER CONTROL dialog (Figure 3-55) permits the operator to select the downstream autogain setpoint and individually enable or disable several CMI transceiver functions.

- *DS Autogain* - Allows operator to enable/disable downstream autogain
- *US Autogain* - Allows operator to enable/disable upstream autogain
- *Autostats* - Allows operator to enable/disable the automatic collection of status and communication statistics for this CMI
- *Power Amp* - Allows operator to enable/disable power amplifier (downstream output)
- *Primary Receiver* - Allows operator to enable/disable primary receiver (upstream input)
- *Diversity Receiver* - Allows operator to enable/disable diversity receiver (upstream input)

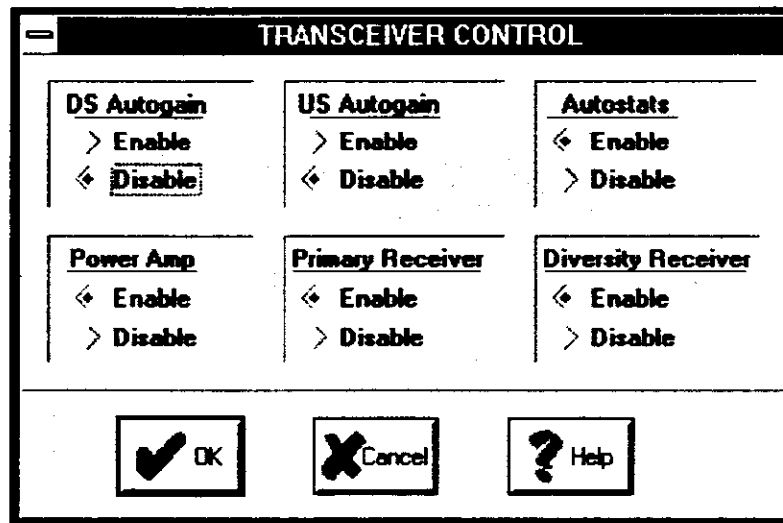

Figure 3-55. TRANSCEIVER CONTROL Dialog

3.5.5 CMI Administrative Data

The CMI ADMINISTRATIVE DATA message window (Figure 3-56) is displayed when the View Info button is selected at the CMI CONTROL PANEL dialog. This message window permits the operator to view the data that was entered when

the selected CMI was added, and to add or modify reference data.

- *CMI Neuron Chip ID* - Neuron® chip identification number in hexadecimal format.
- *CMI Serial Number* - Identification of the specific CMI entered earlier may be modified, or may be entered here.
- *CMI Location* - Location data such as pole #, street address, etc. entered earlier may be modified, or may be entered here.
- *Installation Date* - Time and date the CMI became active.

The image shows a software dialog box titled "CMI ADMINISTRATIVE DATA". It contains the following fields and values:

- CMI Neuron Chip ID**: [Empty text box]
- CMI Serial Number**: 969T12M10033
- CMI Location**: 955 Perimeter Road
- Installation Date**: [Empty text box]

At the bottom right of the dialog is an "OK" button with a checkmark icon.

Figure 3-56. CMI ADMINISTRATIVE DATA Dialog

3.5.6 CMI Communications Statistics

The CMI COMMUNICATIONS STATISTICS dialog (Figure 3-57) displays the communications statistics between the selected CMI and its controlling HIC. Two columns are displayed, Total and Delta. The Total column indicates the number of events since the last Clear Stats selection, the Delta column indicates the number of events since the last time that Update Stats was selected. (Note that all counters roll over at 65536.)

- *Message Processed* - Number of times CMI poll responses have been received within specified time. Counter value “rolls over” after 65,536.
- *Neuron Timeouts* - Number of times a poll response has not been received from selected CMI within timeout period
- *Demodulator Timeouts* - Number of times upstream data from selected CMI has not been correctly demodulated.
- Update Stats - When selected, this button updates the displayed numbers.
- Clear Stats - When selected, this button clears displayed numbers from both columns and restarts the counters.

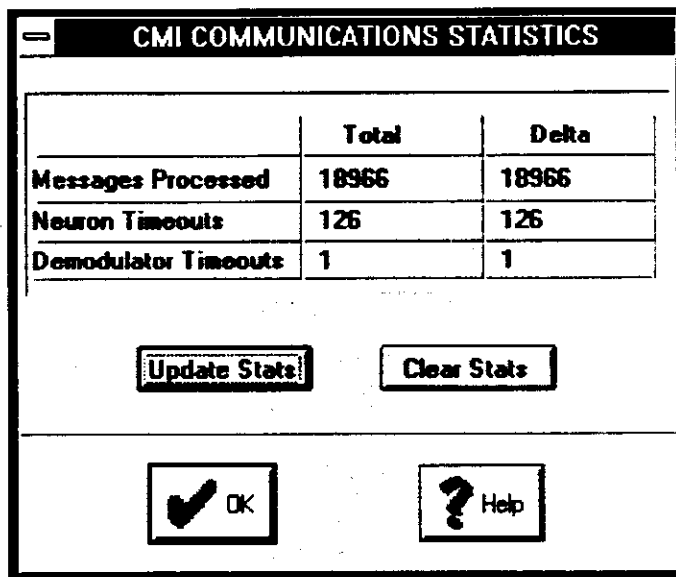

Figure 3-57. CMI COMMUNICATIONS STATISTICS Dialog

3.5.7 CMI PLL Status Display

The CMI PLL STATUS message window (Figure 3-58) displays any of the CMI's ten Phase Locked Loops that are in an unlocked (failed) condition. In normal operation, the status window contains a statement that all phase-locked loops are locked.

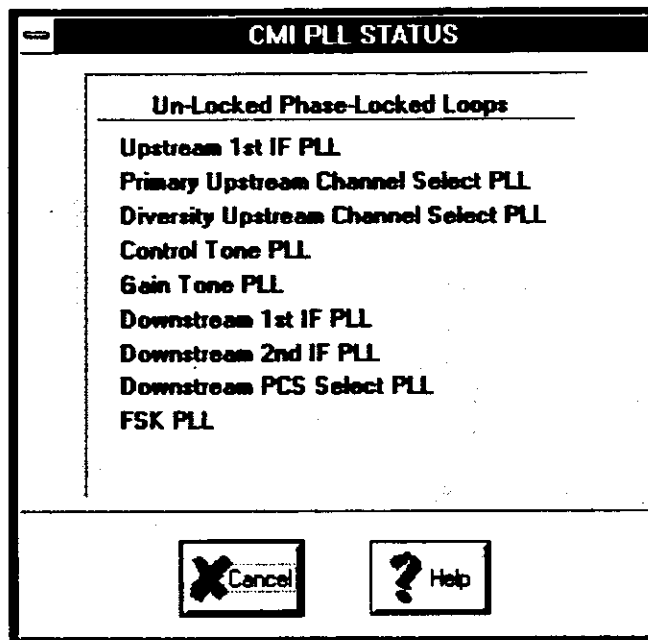

Figure 3-58. CMI PLL STATUS Message

3.5.8 CMI Reset Control

The CMI RESET CONTROL dialog (Figure 3-59) permits a user to select between two sets of CMI reset values, and it performs a soft reset when **OK** is selected. The **Defaults** button resets to default settings; the **Last Value** button resets to last values saved. The reset values selected are used after both power-on resets and soft resets. See paragraph 4.8.2 for a list of default values and important procedural information.

NOTE

For proper system operation, the US Autogain and DS Autogain must be Disabled prior to resetting the CMI. After the reset has occurred and the CMI Upstream attenuators reflect the new values (either default or last values), then the CMI UPSTREAM POWER dialog must be selected, the attenuator values changed if desired, and the **OK** button selected; regardless of whether the attenuators were changed or not. This must be performed prior to re-activating autogain to ensure that the upstream attenuators maintain the new (reset) value.

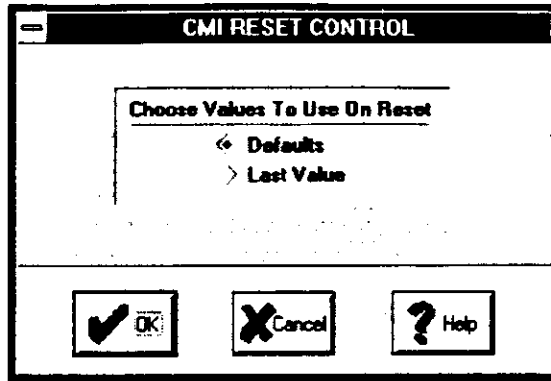

Figure 3-59. CMI RESET CONTROL Dialog

3.5.9 CMI Alarms Enable/Disable

The CMI ALARMS ENABLE/DISABLE dialog (Figure 3-60) contains check boxes for specific CMI alarms. When a box is checked, that particular type of alarm is reported. The operator is cued to check for an alarm by the color of the CMI icon on the HIC CONTROL PANEL dialog. (Also, the icon for the associated HIC will display in yellow on the HEADEND CONTROL PANEL dialog. Alarm details are obtained through the **Alarms** menu on the HEADEND CONTROL PANEL dialog (see paragraph 3.3.8).

- *Activate All Alarms* - Selection of this button selects all alarm check boxes that are accessible to the operator (not gray).
- *Deactivate All Alarms* - Selection of this button deselects all alarm check boxes that are accessible to the operator (not gray).
- *Max Upstream Output Power* - Allows manual setting of the maximum allowable upstream output power. When the output power exceeds this level, a US Power Out Of Range alarm is generated.

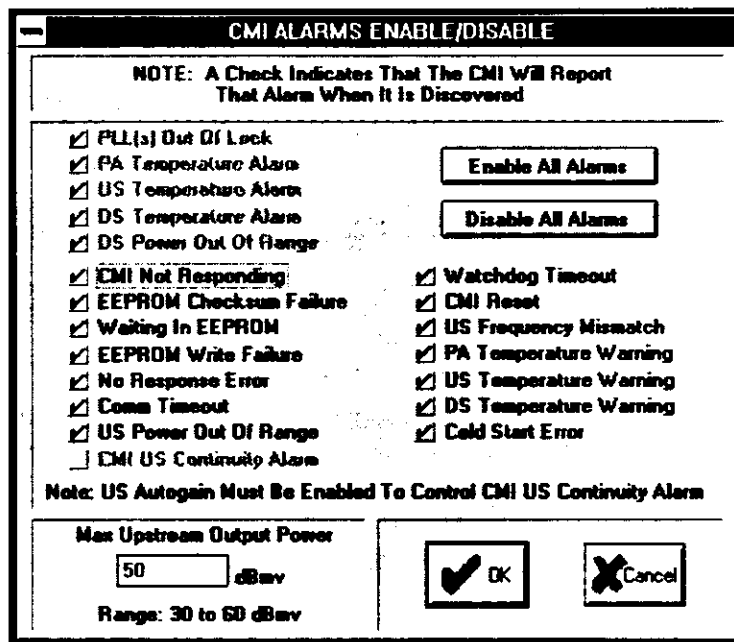

Figure 3-60. CMI ALARMS ENABLE/DISABLE Dialog

3.5.10 PING CMI

The PING CMI dialog (Figure 3-61) allows the Super-User to send a test signal to a selected CMI to manually check its upstream (reverse link) continuity. When the dialog is displayed, both downstream and upstream autogain signals for that CMI are turned off, and the upstream receive pedestals for that CMI are turned on. The test signal uses a different frequency than that used by upstream autogain so that it is easily visible on a spectrum analyzer and to avoid conflict with other CMIs running upstream autogain.

- Test Signal ON/Send - When Test Signal ON and Send are selected, a message is transmitted to activate the test signal.
- Test Signal OFF/Exit - The test signal is turned off when Test Signal OFF and Send are selected, or when the dialog is closed by selecting Exit or double-clicking the dialog control box. If upstream and/or downstream autogain were on prior to display of the PING CMI dialog, the corresponding autogain is re-enabled when the dialog is closed. Likewise, the receive pedestals for the selected CMI return to their prior state.

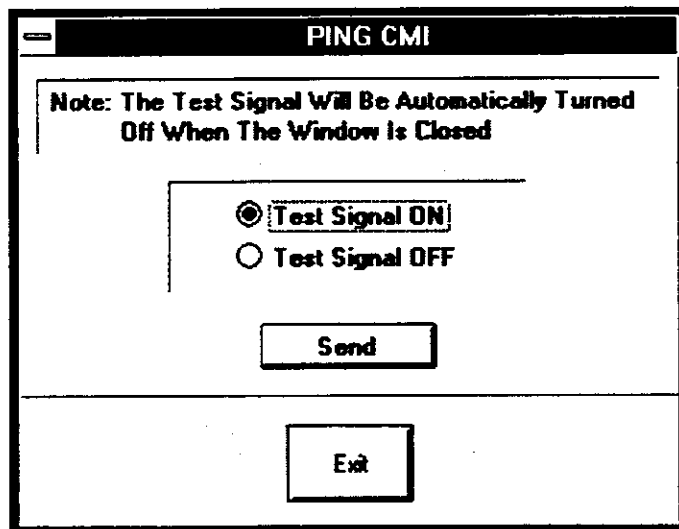

Figure 3-61. PING CMI Dialog

3.5.11 US SETPOINT INITIALIZATION

The US SETPOINT INITIALIZATION dialog (Figure 3-62) allows the Super-User to change the upstream (reverse link) autogain setpoints as well as the upstream control tone attenuator value. To use this dialog, the Super-User must first set the following conditions:

- 1) Out Of Service Indicator OFF selected at the CMI OUT OF SERVICE dialog (Figure 3-27) to avoid creating numerous out of service alarms
 - 2) Autostats, downstream autogain, upstream autogain, and Primary Rx and Diversity Rx disabled for ALL CMIs assigned to a given HIC
 - 3) Start US Setpoint Initialization button selected at HIC CONTROL PANEL.
- *Primary and Diversity* - The up and down arrows and graphical level indicator are used in conjunction with observations on a spectrum analyzer display to independently set the primary and diversity receive pedestals at -52 dBmV. Each increment of the graphical level indicator is approximately 0.5 dB with a total adjustment range of 20 dB.
 - *Set US Control Tone Attenuator* - The control tone attenuator set capability is repeated in this dialog as a convenience (see paragraph 3.5.2).
 - *CMI US Attenuator Values* - Shows the Primary Attenuation and Diversity Attenuation levels as of the last Update; shows the Combined Attenuation level set in the CMI UPSTREAM POWER dialog (see paragraph 3.5.2).
 - *Status* - The Status indicator is red while each setpoint update is in process and then turns to green when the update is complete.
 - Update - Select this button after moving either the *Primary* or the *Diversity* level with the up or down arrows to effect the change.
 - Exit - when selected, the last values sent with Update are resent and are saved to flash memory for use in power-up restoration. Selecting Cancel will restore the upstream primary and diversity setpoints and the control attenuators to the values that existed prior to entering the US SETPOINT INITIALIZATION dialog. Both upstream autogain and the receive pedestals are disabled when either EXIT or CANCEL is selected.

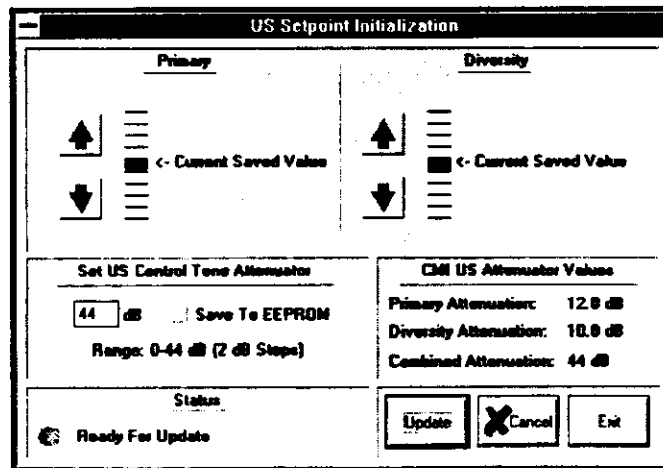

Figure 3-62. US SETPOINT INITIALIZATION Dialog

SECTION 4 OPERATING PROCEDURES

4.1 HEADEND EQUIPMENT TURN-ON/TURN-OFF

4.1.1 Energizing Primary/Expansion Rack

This procedure is used to turn-on either the primary or expansion rack. The procedure covers distributing the 115 Vac power and +24V to the rack-installed equipment. Turn-on and turn-off of the optional +24V Power Supply is included as part of energizing and deenergizing the rack. Turn-on and turn-off procedures for the installed Headend Control Unit (HECU) and Headend Interface Converters (HICs) are covered separately.

4.1.1.1 115 Vac Power Source Turn-on Procedure

- a. Ensure that the surge suppressor power cable is connected to the 115 Vac power source.
- b. Set the surge suppressor switch to ON and observe that the red power indicator lights.

4.1.1.2 +24V Power Source Turn-on Procedure

- a. If the optional +24V Power Supply is installed, ensure that its power cable is connected to the Surge Suppressor.
- b. Set the +24V Power Supply switch to ON and observe that DS1 indicator lights and meter indicates +24V.
- c. At the rear of the rack, set the +24 VDC BUSBAR POWER circuit breaker to ON.

4.1.2 Deenergizing Primary/Expansion Rack

This procedure is used to turn-off either the Primary or Expansion rack.

4.1.2.1 +24V Power Source Turn-off Procedure

- a. Set the +24V Power Supply switch to OFF and observe that DS1 indicator goes out.
- b. At the rear of the rack, set the +24 VDC BUSBAR POWER circuit breaker to OFF

4.1.2.2 115 Vac Power Source Turn-off Procedure

Set the surge suppressor switch to OFF and observe that the red power indicator goes out.

4.1.3 Headend Control Unit (HECU) Turn-on/Turn-off Procedure

The HECU is installed only in the Primary rack. For convenience, once the HECU has been energized, the surge suppressor circuit breaker can be used to turn off the HECU. For additional information on the individual components of the HECU, refer to the reference data provided at installation.

- a. Ensure the HECU monitor and computer power cables are connected to the surge suppressor
- b. At the HECU front panel, open door for access to monitor.
- c. Turn on monitor and observe that power indicator lights.
- d. Turn on computer and observe power indicator lights.
- e. After the computer runs the boot-up routine, observe that the monitor displays CONFIGURATION OPTIONS dialog.

4.1.4 Headend Interface Converter (HIC) Turn-on/Turn-Off Procedure

Each rack is capable of containing up to 14 individual HICs. Each rack-installed HIC operates independently of the others. The HIC has only one operating control which is the power switch.

- a. At HIC front panel, set power switch to **1** and observe that PWR indicator lights and fan is running.
- b. To turn-off HIC, set PWR switch to **0** and observe that PWR indicator goes out.

4.2 HECU SOFTWARE PROCEDURES

The following procedures are provided for performing common tasks with respect to the HECU software.

4.2.1 Initializing the HECU Software Program

The HECU operating software normally is initialized by power-up or reset. If the Windows™ Program Manager is displayed, the program may be initialized by double-clicking the HECU icon. The message **Initializing LONWORKS Network Interface** is displayed, followed by the CONFIGURATION OPTIONS dialog.

The dialog displays the query: **Do you want to Restore a Pre-existing Configuration?** To accept the default system configuration (no HICs or CMIs installed), select the **No** button. The **HEADEND CONTROL PANEL** dialog (Figure 3-5) appears.

To initialize the system with a configuration that has been previously saved in a configuration file, do the following:

- a. Select the **Yes** button. The **OPEN** dialog appears.
- b. From the **OPEN** dialog, select any one of the **test2*. * .*** files displayed to reload the last saved configuration. To confirm selection, click **OK**.
- c. To exit from the **OPEN** dialog without changing configuration, select **Cancel**. The **HEADEND CONTROL PANEL** dialog appears.
- d. If a configuration database file is selected, the **INITIALIZATION OPTIONS** dialog appears with the query **Do you want to Reinitialize the HICs and CMIs?:**
 - 1) Select **No** to restart the HECU operating software with the last saved HIC and CMI parameters. This option is usually used when the HECU was shut down while the HIC - CMI system was operating normally. Selecting **No** will not interrupt cellular phone traffic. Selecting **No** does not reinitialize HICs or

CMI and therefore will not re-acquire any CMI or HIC that may have been deleted.

CAUTION

If one or more devices has an alarm—for example, CMI Not Responding—while a configuration is being restored, it is very important to open the control panel dialog for each such device and determine whether the problem that caused the alarm is still present. A quick check typically includes manually updating the dialog status blocks (Get Status) and then observing whether any further alarms result from the status update. If there are further alarms, be sure to correct the problem: Once the alarm is closed, the HECU displays will show a normally operating system, *even though the alarmed device may be functionally deleted from the system.*

- 2) Select Yes to bring the HECU operating software back on line after first reinitializing all the HICs to last saved parameters, then reacquiring all the CMIs. This option is required whenever the CMIs and HICs are deleted prior to shutting down the HECU. Selecting Yes will re-acquire any attached CMIs or HICs that were deleted, either accidentally or intentionally, so long as they have two-way communications. Because the HICs are reinitialized during the Restore process, a short interruption in cellular phone traffic will occur when re-acquiring HICs and CMIs that have been operating normally while the HECU was shut down.

4.2.2 Logging In

Logging in and setting authorized user parameters is the responsibility of the Super-User. This is accomplished using the HEADEND CONTROL PANEL dialog menu bar.

4.2.2.1 **Increasing Privileges**

- a. At the HEADEND CONTROL PANEL dialog, select **Privileges/Increase Privileges**. The HECU SYSTEM ACCESS dialog appears.
- b. Enter the super-user password and click OK to return to the HEADEND CONTROL PANEL SUPER-USER dialog.

4.2.2.2 **Changing Passwords**

- a. At the HEADEND CONTROL PANEL dialog, select **Privileges/Change Password**. The CHANGE PASSWORD dialog appears.
- b. Follow the on-screen instructions to change the Super-User and/or User password.

4.2.2.3 **Modifying Privileges**

At the HEADEND CONTROL PANEL dialog, select **Modify Privileges** and follow the on-screen instructions to modify the HECU, HIC and CMI Privileges.

4.2.3 Logging Out and Back In

4.2.3.1 **Logging Out**

At the HEADEND CONTROL PANEL dialog, select **Privileges/Logout of HECU** and follow the on-screen instructions to log out. When logged out, the HEADEND CONTROL PANEL dialog title bar changes to HEADEND CONTROL PANEL INTERFACE DISABLED.

4.2.3.2 **Logging Back On**

- a. At the HEADEND CONTROL PANEL INTERFACE DISABLED dialog, select **Privileges/Increase Privileges** and observe HECU SYSTEM ACCESS dialog appears.
- b. Enter the Super-User or User password and click **OK** to return to the HEADEND CONTROL PANEL dialog at the authorized access level.

4.2.4 Shutting Down the HECU Software Program

Shutting down the HECU monitoring and control software is similar to exiting from most other Windows™-based programs. Any of the following will initiate the software shutdown routine, causing the display of the SHUTDOWN ??? dialog (Figure 3-34):

- Double-clicking on the control box in the upper left corner of the HEADEND CONTROL PANEL dialog
- Pressing the [ALT][F4] key combination
- Invoking the Windows™ Task Manager ([CONTROL][ESCAPE] key combination)
- Pressing the [ESCAPE] key from the HEADEND CONTROL PANEL

Shutting down the HECU software has no effect on the call-handling operation of the HICs and CMIs connected to the HECU, only on the ability to monitor and control these devices. Whenever shutting down the HECU, consider the desired state to which the attached devices are to be restored when the HECU software is restarted (paragraph 4.2.1):

- If the desired restoration state for the HICs and CMIs is the same as their present state, the operator should execute a **Configuration/Save** from the HEADEND CONTROL PANEL menu bar before shutting down.
- If the desired restoration state for the HICs and CMIs is already saved, the operator may shut down without saving the current configuration. However, when the chosen pre-existing configuration is restored (paragraph 4.2.1), the Reinitialize option must be used to ensure that all settings are returned to the saved configuration.

4.3 **ASSIGNMENT, CONTROL AND MONITORING OF HICs AND CMIs**

The procedures are used for both Primary and Expansion racks. Installed HICs are identified in each rack by numbers HIC 1 through HIC 14 on the HEADEND CONTROL PANEL dialog. Similarly, installed CMIs in each sector are identified by numbers CMI 1 through CMI 24 on the HIC CONTROL PANEL dialog.

4.3.1 HIC Assignment, Control and Monitoring

4.3.1.1 **Add HIC to Rack**

To activate a physically installed HIC in either rack, use the HEADEND CONTROL PANEL dialog:

NOTE

This procedure contains the operating ranges and parameters allowed to be entered for the individual HIC. The user is responsible for determining the actual value for each parameter entered during the HIC setup.

If available, a barcode reader can be attached to the HECU to allow for error-free entry of the HIC Neuron® ID in lieu of using the keyboard for manual entry.

- a. At the HEADEND CONTROL PANEL dialog, double-click on the desired HIC icon (HIC 1–HIC 14). The ADD HIC dialog appears.
- b. Type in data in the following boxes (do not press **ENTER**):
 - *Enter Neuron ID* using 12 hexadecimal characters (required data). If insufficient characters are used, an **ENTRY ERROR** dialog will appear.
 - *Enter Cell ID* using the appropriate information (reference data, not required)
 - *Enter Serial Number* of the HIC (reference data, not required)
- c. Type in *Upstream Frequencies* values for *Alpha / Beta / Gamma* sectors (For proper system operation, each Primary frequency must be set at least 2 MHz away from (normally below), and not more than 4.75 MHz away from, the related Diversity frequency).
- d. Type in *Downstream Channel* number.
- e. Select *Downstream Channel* mode: *STD, HRC, or IRC*.
- f. Type in desired *PCS Frequency*:
- g. Confirm that the following options are set to the Enable position:
 - Power Output
 - Reference Tone
 - Control Tone
- h. Confirm that *Reset* option is set to Last Values. (This setting controls whether the last saved values or default values are used after a HIC reset.)
- i. Select OK to add the new HIC.
- j. Verify that the HEADEND CONTROL PANEL dialog reappears, and that the numbered panel representing the added HIC appears in green.

4.3.1.2 **Change, Review, or Save Active HIC Status**

To change, review, or save the current operating parameters for an active HIC in either rack, use the HEADEND CONTROL PANEL dialog:

NOTE

This procedure contains the operating ranges and parameters allowed to be entered for the individual HIC. The user is responsible for determining the actual value for each parameter entered during the HIC setup.

- a. At the HEADEND CONTROL PANEL dialog, double-click on desired active HIC (HIC 1–HIC 14). The HIC CONTROL PANEL dialog appears.
- b. At *Choose Sector*, click Alpha, Beta, or Gamma to display the current sector parameter values.
- c. Proceed to paragraphs 4.3.1.2.1 through 4.3.1.2.7 as needed.

NOTE

In general, HIC and CMI control panel attenuator and power settings are determined by gains and losses of the Cable Plant between the HIC and the CMI. These levels are typically determined during the first installation of the hardware at the location and should continue to be used unless a major change occurs to the cable plant. The correct settings should be available and are unique to each HIC sector and the associated CMIs.

A power level displayed as three dashes (- - -) indicates that the power level is too low for the system to read reliably.

4.3.1.2.1 **Precautions to Observe When Making Frequency Changes**

Take the following precautions when changing the upstream (reverse), downstream (forward), or PCS frequency settings.

NOTE

The operating software requires reliable communications between the HIC and the CMIs in order to effect a change of frequency. When communications with one or more CMIs fails during a “Change Frequency” message, and the alarm Review Details indicates a “Communications Error Occurred Sending Message add_hic-msg”, a conflict between the HIC and HECU has arisen and must be handled properly.

- a. To avoid any Out Of Service alarms, select Out Of Service Indicator OFF at the CMI OUT OF SERVICE dialog (Figure 3-27).

- b. If changing the Upstream (US) Frequency, disable US Autogain for **all** sectors with CMIs attached, using the CMI GROUP CONTROL dialog.
- c. If changing the Downstream (DS) Frequency, disable the DS Autogain for **all** sectors with CMIs attached, using the CMI GROUP CONTROL dialog.
- d. If changing the PCS Frequency, disable both DS Autogain and US Autogain for **all** sectors with CMIs attached, using the CMI GROUP CONTROL dialog.
- e. Confirm that there are no communications problems with any CMIs attached to the HIC. If unsure of the present status, perform a CMI Group Control function in all sectors such as disabling the Power Amp and then re-enabling it, and wait for the message queue to return to zero. Any non-communicating CMIs will cause a CMI Not Responding alarm.
- f. Fix the communications problems or delete any CMI that causes a CMI Not Responding alarm. The CMI(s) can be deleted by answering No to the "Require Communications" question. In this case, it is very important to note and **record** the CMI location and the data in the CMI ADMINISTRATIVE DATA dialog. This information will be required to re-install the CMI(s) after the HIC frequency change has been made.
- g. From the HIC CONTROL PANEL dialog, change the appropriate frequency.

NOTE

In the following steps, if a CMI Not Responding alarm occurs at Step *h*, do not open any CMI CONTROL PANEL dialog until after step *i*, or else a Frequency mismatch could be created between the HIC and the CMI(s). It is important that the HIC CONTROL PANEL frequency indicators are displaying the correct value before a CMI CONTROL PANEL dialog is opened.

- h. Wait a few moments and confirm that after HIC Message queue reduces to zero, there are no CMI Not Responding alarms. If there are, continue with step *i*; otherwise proceed to step *k*.
- i. At HIC CONTROL PANEL dialog, observe appropriate Frequency or Channel indicator. If display indicates that frequency did not change, select Get Status and confirm that the frequency indicator does not update.
- j. Delete any CMI that caused a CMI Not Responding alarm. The CMI(s) can be deleted by answering No to the "Require Communications" question. In this case, it is very important to note and **record** the CMI location and the data in the CMI ADMINISTRATIVE DATA dialog. This information will be required to re-install the CMI(s) after the HIC frequency change has been made.
- k. Re-install any CMIs that were removed, using the CMI information recorded earlier. Note that this will require that communications be established between the HIC and CMI(s). If these CMIs were deleted without communications, because communication problems, then the problem will need to be rectified before the CMIs can be added. When the CMIs are added, they will be activated at the new frequencies.

4.3.1.2.2 Upstream Frequencies Control

- a. Before changing frequency, take appropriate precautions per paragraph 4.3.1.2.1.
- b. At HIC CONTROL PANEL dialog, click on *Choose Sector* Alpha, Beta, or Gamma button to select *Current Sector*, if needed. Observe that *Current Sector*: displays the sector selected.
- c. At *Upstream Frequencies*, click Control and observe that UPSTREAM FREQUENCY dialog appears.
- d. For each sector (*Alpha, Beta, and Gamma*), set the following:
- e. *Primary Frequency*.
- f. *Diversity Frequency* (at least 2 MHz, but not more than 4.75 MHz, above the Primary Frequency)
- g. Click OK.

4.3.1.2.3 Downstream Channel Control

- a. Before changing frequency, take appropriate precautions per paragraph 4.3.1.2.1.
- b. At HIC CONTROL PANEL dialog, click Control button for *Downstream Channel*, and observe that DOWNSTREAM CHANNEL dialog appears.
- c. At *Enter New Downstream Channel Value*, type in desired channel number.
- d. At *Channel Type*, select desired type.
- e. Click OK.

4.3.1.2.4 PCS Frequency Control

NOTE

The PCS frequency can be set using either the transmit frequency or designated channel number.

- a. Before changing frequency, take appropriate precautions per paragraph 4.3.1.2.1.
- b. At HIC CONTROL PANEL dialog, click Control on *PCS Frequency* and observe that PCS FREQUENCY dialog appears.
- c. At *Entry Options*, select either *Enter Frequency* or *Enter Channel*.
- d. For *Enter Frequency*, type in desired frequency (1930–1945 MHz in 0.05 MHz steps)
- e. For *Enter Channel*, type in channel number (see Table 4-1 for reference).
- f. Click OK and observe that the updated PCS Frequency appears on the HIC CONTROL PANEL dialog.

Table 4-1. PCS Channel to Frequency Cross Reference

PCS CDMA CHANNEL NUMBER	CMI PCS TRANSMIT FREQ (MHz)	CMI PCS RECEIVE FREQ (MHz)	PCS CDMA CHANNEL NUMBER	CMI PCS TRANSMIT FREQ (MHz)	CMI PCS RECEIVE FREQ (MHz)
1	1930.05	1850.05	48	1932.40	1852.40
2	1930.10	1850.10	49	1932.45	1852.45
3	1930.15	1850.15	50	1932.50	1852.50
4	1930.20	1850.20	51	1932.55	1852.55
5	1930.25	1850.25	52	1932.60	1852.60
6	1930.30	1850.30	53	1932.65	1852.65
7	1930.35	1850.35	54	1932.70	1852.70
8	1930.40	1850.40	55	1932.75	1852.75
9	1930.45	1850.45	56	1932.80	1852.80
10	1930.50	1850.50	57	1932.85	1852.85
11	1930.55	1850.55	58	1932.90	1852.90
12	1930.60	1850.60	59	1932.95	1852.95
13	1930.65	1850.65	60	1933.00	1853.00
14	1930.70	1850.70	61	1933.05	1853.05
15	1930.75	1850.75	62	1933.10	1853.10
16	1930.80	1850.80	63	1933.15	1853.15
17	1930.85	1850.85	64	1933.20	1853.20
18	1930.90	1850.90	65	1933.25	1853.25
19	1930.95	1850.95	66	1933.30	1853.30
20	1931.00	1851.00	67	1933.35	1853.35
21	1931.05	1851.05	68	1933.40	1853.40
22	1931.10	1851.10	69	1933.45	1853.45
23	1931.15	1851.15	70	1933.50	1853.50
24	1931.20	1851.20	71	1933.55	1853.55
25	1931.25	1851.25	72	1933.60	1853.60
26	1931.30	1851.30	73	1933.65	1853.65
27	1931.35	1851.35	74	1933.70	1853.70
28	1931.40	1851.40	75	1933.75	1853.75
29	1931.45	1851.45	76	1933.80	1853.80
30	1931.50	1851.50	77	1933.85	1853.85
31	1931.55	1851.55	78	1933.90	1853.90
32	1931.60	1851.60	79	1933.95	1853.95
33	1931.65	1851.65	80	1934.00	1854.00
34	1931.70	1851.70	81	1934.05	1854.05
35	1931.75	1851.75	82	1934.10	1854.10
36	1931.80	1851.80	83	1934.15	1854.15
37	1931.85	1851.85	84	1934.20	1854.20
38	1931.90	1851.90	85	1934.25	1854.25
39	1931.95	1851.95	86	1934.30	1854.30
40	1932.00	1852.00	87	1934.35	1854.35
41	1932.05	1852.05	88	1934.40	1854.40
42	1932.10	1852.10	89	1934.45	1854.45
43	1932.15	1852.15	90	1934.50	1854.50
44	1932.20	1852.20	91	1934.55	1854.55
45	1932.25	1852.25	92	1934.60	1854.60
46	1932.30	1852.30	93	1934.65	1854.65
47	1932.35	1852.35	94	1934.70	1854.70

Table 4-1. PCS Channel to Frequency Cross Reference (Continued)

PCS CDMA CHANNEL NUMBER	CMI PCS TRANSMIT FREQ (MHz)	CMI PCS RECEIVE FREQ (MHz)	PCS CDMA CHANNEL NUMBER	CMI PCS TRANSMIT FREQ (MHz)	CMI PCS RECEIVE FREQ (MHz)
95	1934.75	1854.75	140	1937.00	1857.00
96	1934.80	1854.80	141	1937.05	1857.05
97	1934.85	1854.85	142	1937.10	1857.10
98	1934.90	1854.90	143	1937.15	1857.15
99	1934.95	1854.95	144	1937.20	1857.20
100	1935.00	1855.00	145	1937.25	1857.25
101	1935.05	1855.05	146	1937.30	1857.30
102	1935.10	1855.10	147	1937.35	1857.35
103	1935.15	1855.15	148	1937.40	1857.40
104	1935.20	1855.20	149	1937.45	1857.45
105	1935.25	1855.25	150	1937.50	1857.50
106	1935.30	1855.30	151	1937.55	1857.55
107	1935.35	1855.35	152	1937.60	1857.60
108	1935.40	1855.40	153	1937.65	1857.65
109	1935.45	1855.45	154	1937.70	1857.70
110	1935.50	1855.50	155	1937.75	1857.75
111	1935.55	1855.55	156	1937.80	1857.80
112	1935.60	1855.60	157	1937.85	1857.85
113	1935.65	1855.65	158	1937.90	1857.90
114	1935.70	1855.70	159	1937.95	1857.95
115	1935.75	1855.75	160	1938.00	1858.00
116	1935.80	1855.80	161	1938.05	1858.05
117	1935.85	1855.85	162	1938.10	1858.10
118	1935.90	1855.90	163	1938.15	1858.15
119	1935.95	1855.95	164	1938.20	1858.20
120	1936.00	1856.00	165	1938.25	1858.25
121	1936.05	1856.05	166	1938.30	1858.30
122	1936.10	1856.10	167	1938.35	1858.35
123	1936.15	1856.15	168	1938.40	1858.40
124	1936.20	1856.20	169	1938.45	1858.45
125	1936.25	1856.25	170	1938.50	1858.50
126	1936.30	1856.30	171	1938.55	1858.55
127	1936.35	1856.35	172	1938.60	1858.60
128	1936.40	1856.40	173	1938.65	1858.65
129	1936.45	1856.45	174	1938.70	1858.70
130	1936.50	1856.50	175	1938.75	1858.75
131	1936.55	1856.55	176	1938.80	1858.80
132	1936.60	1856.60	177	1938.85	1858.85
133	1936.65	1856.65	178	1938.90	1858.90
134	1936.70	1856.70	179	1938.95	1858.95
135	1936.75	1856.75	180	1939.00	1859.00
136	1936.80	1856.80	181	1939.05	1859.05
137	1936.85	1856.85	182	1939.10	1859.10
138	1936.90	1856.90	183	1939.15	1859.15
139	1936.95	1856.95	184	1939.20	1859.20

Table 4-1. PCS Channel to Frequency Cross Reference (Continued)

PCS CDMA CHANNEL NUMBER	CMI PCS TRANSMIT FREQ (MHz)	CMI PCS RECEIVE FREQ. (MHz)	PCS CDMA CHANNEL NUMBER	CMI PCS TRANSMIT FREQ (MHz)	CMI PCS RECEIVE FREQ (MHz)
185	1939.25	1859.25	231	1941.55	1861.55
186	1939.30	1859.30	232	1941.60	1861.60
187	1939.35	1859.35	233	1941.65	1861.65
188	1939.40	1859.40	234	1941.70	1861.70
189	1939.45	1859.45	235	1941.75	1861.75
190	1939.50	1859.50	236	1941.80	1861.80
191	1939.55	1859.55	237	1941.85	1861.85
192	1939.60	1859.60	238	1941.90	1861.90
193	1939.65	1859.65	239	1941.95	1861.95
194	1939.70	1859.70	240	1942.00	1862.00
195	1939.75	1859.75	241	1942.05	1862.05
196	1939.80	1859.80	242	1942.10	1862.10
197	1939.85	1859.85	243	1942.15	1862.15
198	1939.90	1859.90	244	1942.20	1862.20
199	1939.95	1859.95	245	1942.25	1862.25
200	1940.00	1860.00	246	1942.30	1862.30
201	1940.05	1860.05	247	1942.35	1862.35
202	1940.10	1860.10	248	1942.40	1862.40
203	1940.15	1860.15	249	1942.45	1862.45
204	1940.20	1860.20	250	1942.50	1862.50
205	1940.25	1860.25	251	1942.55	1862.55
206	1940.30	1860.30	252	1942.60	1862.60
207	1940.35	1860.35	253	1942.65	1862.65
208	1940.40	1860.40	254	1942.70	1862.70
209	1940.45	1860.45	255	1942.75	1862.75
210	1940.50	1860.50	256	1942.80	1862.80
211	1940.55	1860.55	257	1942.85	1862.85
212	1940.60	1860.60	258	1942.90	1862.90
213	1940.65	1860.65	259	1942.95	1862.95
214	1940.70	1860.70	260	1943.00	1863.00
215	1940.75	1860.75	261	1943.05	1863.05
216	1940.80	1860.80	262	1943.10	1863.10
217	1940.85	1860.85	263	1943.15	1863.15
218	1940.90	1860.90	264	1943.20	1863.20
219	1940.95	1860.95	265	1943.25	1863.25
220	1941.00	1861.00	266	1943.30	1863.30
221	1941.05	1861.05	267	1943.35	1863.35
222	1941.10	1861.10	268	1943.40	1863.40
223	1941.15	1861.15	269	1943.45	1863.45
224	1941.20	1861.20	270	1943.50	1863.50
225	1941.25	1861.25	271	1943.55	1863.55
226	1941.30	1861.30	272	1943.60	1863.60
227	1941.35	1861.35	273	1943.65	1863.65
228	1941.40	1861.40	274	1943.70	1863.70
229	1941.45	1861.45	275	1943.75	1863.75
230	1941.50	1861.50			

4.3.1.2.5 Upstream Power Control

- a. At the HIC CONTROL PANEL dialog, click on *Choose Sector* Alpha, Beta, or Gamma button to select *Current Sector*, if needed. Observe that *Current Sector*: displays the sector selected.
- b. At *Upstream Power*, click Control. The HIC UPSTREAM POWER dialog appears.
- c. For each sector (*Alpha, Beta, and Gamma*), set the following:
- d. *US Attenuator Setting*.
- e. *Autogain Setpoint*.
- f. *Set Ingress Threshold*.
- g. Select *EEPROM Option* Save button and click OK.
- h. Proceed to next paragraph.

4.3.1.2.6 Downstream Power Control

- a. At the HIC CONTROL PANEL dialog, click on *Choose Sector* Alpha, Beta, or Gamma button to select *Current Sector*, if needed. Observe that *Current Sector*: displays the sector selected.
- b. At *Downstream Power*, click Control and observe that HIC DOWNSTREAM POWER dialog appears.
- c. At *Power Output*, select Enable.
- d. At *DS Autogain Set Points*, type in the appropriate value for all three sectors.
- e. At *DS Attenuator Setting*, type in attenuation value as needed.
- f. Select *Save to Flash*, then click OK.
- g. Proceed to next paragraph.

4.3.1.2.7 Reference and Control Tone Control

- a. At the HIC CONTROL PANEL dialog, click Control button for *Reference and Control Tone*, and observe that REFERENCE AND CONTROL TONES dialog appears.
- b. At *Reference Tone*, select Enable.
- c. At *Control Tone*, select Enable.
- d. At *Attenuator Setting*, type in attenuation as needed.
- e. Select *Save to Flash* and click OK.
- f. Proceed to next paragraph.

4.3.1.3 Deactivate HIC (Delete HIC)

To deactivate a currently active HIC in either rack, use the HEADEND CONTROL PANEL dialog.

- a. At the HEADEND CONTROL PANEL dialog, click (once) on desired HIC (HIC 1-HIC 14).

- b. Click Delete HIC. If CMIs are attached, the CONFIRM OPERATION dialog (Figure 3-8) is displayed; go to step c. Otherwise, the DELETE CONTROL dialog (Figure 3-9) appears; go to step d.
- c. If the selected HIC has CMIs attached to it, proceed as follows:
 - 1) At CONFIRM OPERATION dialog, Select No, and double-click selected HIC to display HIC CONTROL PANEL dialog.
 - 2) At HIC CONTROL PANEL dialog, delete all CMIs in each sector (see paragraph 4.3.2.3).
 - 3) Return to HEADEND CONTROL PANEL dialog and again click Delete HIC.

NOTE

It is important to delete all the CMIs in each sector of the selected HIC before deleting the HIC. (The YES response at the CONFIRM OPERATION dialog is provided for emergency HIC deactivation only.) The CMIs should be deleted in the normal fashion, if possible (two-way communications operating). If a CMI cannot be deleted normally due to a communications problem, then that CMI can be deleted by answering NO to the Require Communications question in the DELETE CONTROL dialog. In this case, it is very important to *note and record* the CMI location and the data in the CMI ADMINISTRATIVE DATA dialog. This information may be required when restoring the CMIs after the new HIC is installed.

- d. Respond to DELETE CONTROL dialog according to the following criteria:
 - YES - Normally selected when wishing to ensure that communications with the selected HIC are operating normally before deactivating the unit. A message window will confirm communication status. If communication is successful, the selected unit is deactivated. If not, the DELETE CONTROL dialog is displayed again.
 - NO - Normally selected when communication with selected HIC has been lost; the unit is deactivated immediately without further attempts to communicate with it.
- e. Verify that HEADEND CONTROL PANEL dialog reappears, and that numbered panel icon representing the deactivated HIC appears in gray.

4.3.2 CMI Assignment, Control and Monitoring

4.3.2.1 Add CMI to HIC

To add a physically installed CMI to a HIC, use the HIC CONTROL PANEL dialog:

NOTE

If available, a barcode reader can be attached to the HECU to allow for error-free entry of the CMI Neuron ID data in lieu of using the keyboard for manual data entry.

- a. At the HIC CONTROL PANEL dialog, click on *Choose Sector* Alpha, Beta, or Gamma button to select *Current Sector*.
- b. Observe that *Current Sector*: displays the sector selected.
- c. At the HIC CONTROL PANEL dialog, double-click on desired CMI icon (CMI 1–CMI 24).
- d. Observe that the ADD CMI dialog appears.
- e. Type in data in the following boxes (do not press **ENTER**):
 - Enter CMI Neuron Chip 48 bit ID (in Hex)
 - Enter CMI Serial number (optional, not required)
 - Enter CMI Location (i.e. pole #, street address) (optional, not required)
- f. If desired, change any of the following options from the defaults shown below:
 - *Power Amp* (Disable)
 - *Primary Rx* (Enable)
 - *Diversity Rx* (Enable)
 - *Autostats* (Enable)
 - *DS Autogain* (Disable)
 - *US Autogain* (Disable)
 - *Alarm Disposition* (Clear)
- g. Confirm that *Reset* option is set to Last Values. (This setting controls whether the last saved values or default values are used after a CMI power-on reset.)
- h. Select OK to add the new CMI.
- i. Verify that the HIC CONTROL PANEL dialog reappears, and that the numbered icon representing the added CMI in the selected HIC sector appears in green.

4.3.2.2 Change or Review CMI Status

To change, review, or save the current operating parameters for an active CMI in either rack, use the three dialogs accessed via the Control buttons on the CMI CONTROL PANEL dialog as needed:

- CMI UPSTREAM POWER
- CMI DOWNSTREAM POWER
- TRANSCEIVER CONTROL

NOTE

In general, HIC and CMI control panel attenuator and power settings are determined by gains and losses of the Cable Plant between the HIC and the CMI. These levels are typically determined during the first installation of the hardware at the location and should continue to be used unless a major change occurs to the cable plant. The correct settings should be available and are unique to each HIC sector and the associated CMIs.

A power level displayed as three dashes (- - -) indicates that the power level is too low for the system to read reliably.

4.3.2.2.1 CMI Upstream Power Control

- a. At the CMI CONTROL PANEL dialog, click Control for *Upstream Power*, and observe that CMI UPSTREAM POWER dialog appears.
- b. For each attenuation type in the following:
- c. *Upstream Primary ATTN* as needed.
- d. *Upstream Diversity ATTN* as needed.
- e. *Upstream Combined ATTN* as needed.
- f. *Control Tone ATTN* as needed.
- g. Select *EEPROM Option* setting Save and click OK.

4.3.2.2.2 CMI Downstream Power Control

- a. At the CMI CONTROL PANEL dialog, click Control for *Downstream Power*, and observe that CMI DOWNSTREAM POWER dialog appears.
- b. At *DS Attenuation*, type in attenuation as needed.
- c. Select *EEPROM Option* setting Save and click OK.

4.3.2.2.3 CMI Transceiver Parameters

- a. At the CMI CONTROL PANEL dialog, click Control for *Transceiver Parameters*, and observe that TRANSCEIVER CONTROL dialog appears.
- b. Select Enable or Disable for the following as required:
 - DS Autogain
 - US Autogain
 - Autostat
 - Power Amp
 - Primary Receiver
 - Diversity Receiver
- c. Click OK.

4.3.2.2.4 Reassigning CMI

- a. At the HIC CONTROL PANEL dialog, click on *Choose Sector* Alpha, Beta, or Gamma button to select *Current Sector*, if needed. Observe that *Current Sector*: displays the sector selected.
- b. At the HIC CONTROL PANEL dialog, click (once) on desired CMI icon (CMI 1–CMI 24).
- c. At the HIC CONTROL PANEL dialog, click Reassign CMI and observe that REASSIGN CMI dialog appears.
- d. At *Destination HIC*, select *Rack* and type in *Slot*.
- e. At *Destination CMI*, select *Sector* and type in *Number*.
- f. Click OK.

4.3.2.3 Deactivate CMI (Delete CMI)

To delete (deactivate) a currently active CMI in either rack, use the HEADEND CONTROL PANEL dialog.

- a. At the HEADEND CONTROL PANEL dialog, double-click on the desired HIC icon (HIC 1–HIC 14).
- b. At the HIC CONTROL PANEL dialog, click on *Choose Sector* Alpha, Beta, or Gamma button to select *Current Sector*.
- c. Observe that *Current Sector*: displays the sector selected.
- d. At the HIC CONTROL PANEL dialog, click (once) on desired CMI icon (CMI 1–CMI 24).
- e. Click Delete CMI and observe that DELETE CONTROL dialog appears.
- f. Respond to message by clicking YES (communications required).
- g. Verify that the HIC CONTROL PANEL dialog reappears, and that the numbered CMI representing the deactivated CMI appears in gray.

4.4 SETTING CMI REVERSE LINK SIGNAL LEVEL SETPOINT

The following procedures are used to determine the target reverse link (upstream) output level for all the CMIs assigned to a given HIC in a given sector. This target level is otherwise known as the upstream autogain setpoint. The ideal target level for a single CMI in a simulcast will depend on the number of CMIs in the simulcast.

4.4.1 Determining the Rough Target Level

- a. Measure the reverse link video reference at HIC UPSTREAM TEST POINT for sector of interest (Alpha, Beta, Gamma). Record this value.
- b. At HEADEND CONTROL PANEL dialog, select **Alarms**, then **CMI Out Of Service Control**.
- c. At CMI OUT OF SERVICE dialog, select Out Of Service Indicator OFF to disable all Out Of Service alarms, then select OK.
- d. At HEADEND CONTROL PANEL dialog, select the first HIC to be worked on.

- e. At HIC CONTROL PANEL dialog, select CMI Group Ctl and disable all functions except *Alarms* for all sectors that have CMIs attached, then select OK.
- f. At the HIC CONTROL PANEL dialog, select Start US Setpoint Initialization.
- g. With all CMIs disabled, at appropriate HIC UPSTREAM TEST POINT, measure reverse link CATV noise floor over intended frequency range. (The noise floor at this point will represent the combined noise effects of each fiber node in the sector.)
- h. Calculate the Rough Target for a single CMI by the following formula:

$$\text{Rough Target} = \text{Video Reference} - 31 - 10 \log(n)$$

where n is the number of CMIs in the sector. Record this value.

- e. If Rough Target is less than 5 dB above CATV noise floor, then alternate balancing method must be used (paragraph 4.4.3).
- f. If Rough Target is greater than or equal to 5 dB above the noise floor, proceed to the Upstream Setpoint Initialization procedure, paragraph 4.4.2.

4.4.2 Upstream Setpoint Initialization

- a. At HIC CONTROL PANEL dialog, select Sector and CMI to be set.
- b. Connect Spectrum Analyzer to appropriate sector UPSTREAM TEST POINT on front panel of selected HIC.
- c. Set up Spectrum Analyzer as follows:
 - Center Frequency at midpoint of chosen sector Primary and Diversity upstream frequencies.
 - Frequency Span - 4 MHz.
 - Resolution Bandwidth - 30 kHz
 - Input - 75 Ohms.
 - Amplitude Units to dBmV and scale to 1 dB per div.
 - Input Attenuator - 0 dB.
 - Enable the Display Line and place it at mid screen
 - Select BW and turn on Vid Avg, set for 100 samples average.
 - Adjust Reference Level until the Display Line readout indicates Rough Target value.
- d. At the CMI CONTROL PANEL dialog, select US Setpoint.
- e. Wait a few moments for Upstream Setpoint to take effect and pedestal levels to settle, then observe levels of Primary and Diversity pedestals on Spectrum Analyzer.
- f. Observe the average levels of Primary and Diversity pedestals. If one is below the Rough Target Display Line, increment UP the appropriate setpoint control in the US SETPOINT INITIALIZATION dialog to move Upstream pedestal near mid-screen. If one is above the Rough Target Display Line, increment DOWN the

appropriate setpoint control. (Each increment of the Up/Down indicator is equal to approximately 0.5 dB).

- g. Select Update button.
- h. Observe Status indicator: It is red while updating is in progress and turns green when the update is complete. Wait a few moments for new Upstream Setpoint to take effect, then observe Spectrum Analyzer to determine if another adjustment is required. Continue this process until the final US Setpoint selected produces pedestal levels that average out to Rough Target value ± 0.25 dB.
- i. When satisfied that the setpoint is as close as possible, select Exit at the US SETPOINT INITIALIZATION dialog to save the last setpoint. Note that selecting Cancel will close dialog but will not save correct setpoint value.
- j. Select OK to close CMI CONTROL PANEL dialog.
- k. At HIC CONTROL PANEL dialog, select next CMI in present Sector to be set.
- l. Repeat steps **d** through **k** to complete all CMIs in present Sector.
- m. Repeat steps **b** through **k** to complete all the Sectors in the HIC.
- n. After all CMIs have been set, from HIC CONTROL PANEL dialog, select Stop US Setpoint Initialization.
- o. At HIC CONTROL PANEL dialog, select CMI Group Ctl and enable all functions for all Sectors that have CMIs attached, then select OK.
- p. If additional HICs are to be adjusted, repeat paragraph 4.4.1 for each HIC.
- q. At HEADEND CONTROL PANEL dialog, select **Alarms**, then **CMI Out Of Service Control**.
- r. At the CMI OUT OF SERVICE dialog, select Out Of Service Indicator ON and select all desired alarms, then select OK.

4.4.3 Alternate Balancing Method

In some cases the target level of a single CMI may be close to—or even beneath—the combined CATV noise floor. In these cases the pedestal cannot be used to balance the CMI. Instead a test signal is used.

- a. At HIC CONTROL PANEL dialog, select Stop US Setpoint Initialization.
- b. At CMI UPSTREAM POWER dialog, activate desired CMI by enabling receivers and setting combined reverse link attenuators to nominal values: Primary: 5; Diversity: 5; Combined: 44.
- c. With spectrum analyzer connected to the HIC upstream test point of interest, verify that pedestals are at least 10 dB above noise floor. If necessary, adjust attenuator settings at CMI UPSTREAM POWER dialog.
- d. At CMI CONTROL PANEL dialog, select Ping. At the resulting PING CMI dialog, enable test signals on desired CMI.
- e. Measure power levels of the two test signals and average power of pedestals. Record these values.

- f. Calculate power difference between the test signals and the pedestals., Record these values.
- g. Calculate final target levels for the two test signals of a single CMI by adding Rough Target level—measured in paragraph 4.4.1—to the difference between test signals and the pedestals. (In this way, the test signals are used to gauge when the pedestals are at the desired setpoint for the sector, since the appropriate level is too close to the noise floor to be accurately measured. Note that there will be a separate target level for each CMI signal, Primary and Diversity.) Record final target levels.
- h. With a single CMI enabled, enable test signal and adjust upstream attenuators at CMI UPSTREAM POWER dialog until both primary and diversity test signals are at desired target level. Save these attenuator settings to EEPROM, and record these values.
- i. At TRANSCIVER CONTROL dialog, disable all functions for CMI just adjusted.
- j. Repeat this procedure for each CMI in sector.

4.5 ALARM PROCEDURES

4.5.1 Enabling/Disabling HIC Alarms

- a. At the HEADEND CONTROL PANEL dialog, select **Polling/Polling Interval** and observe POLLING INTERVAL dialog appears.
- b. Select desired polling interval in *Minutes* and *Seconds* and click OK.
- c. At the HEADEND CONTROL PANEL dialog, double-click on desired HIC icon. Observe that HIC CONTROL PANEL dialog appears.
- d. At the HIC CONTROL PANEL, select Enable Alarms. Observe that HIC ALARMS ENABLE/DISABLE dialog appears.
- e. Select individual HIC alarms that are desired to be reported, or select Activate All Alarms to select all alarms for reporting. Click OK to return to HIC CONTROL PANEL dialog.

4.5.2 Enabling/Disabling CMI Alarms

- a. At the HEADEND CONTROL PANEL dialog, select **Polling/Polling Interval** and observe that POLLING INTERVAL dialog appears.
- b. Select desired polling interval in *Minutes* and *Seconds* and click OK.
- c. At the HEADEND CONTROL PANEL dialog, double-click on desired HIC icon. The HIC CONTROL PANEL dialog appears.
- d. At the HIC CONTROL PANEL dialog, double-click on desired CMI icon. The CMI CONTROL PANEL dialog appears.
- e. At the CMI CONTROL PANEL select Enable Alarms. The CMI ALARMS ENABLE/DISABLE dialog appears.

- f. Select Activate All Alarms if desired to report all alarms, or select individual CMI alarms that are desired to be reported. Click OK to return to CMI CONTROL PANEL dialog.

NOTE

The CMI US Continuity Alarm will automatically be grayed out when US Autogain is disabled, to indicate the state of the US Autogain. If the alarm is enabled before US Autogain is disabled, then the alarm will also automatically become enabled again when US Autogain is re-enabled. However, this "alarm state memory" will be overwritten by any subsequent change to the CMI alarm states. In other words, if *any* of the CMI alarm states are changed while US Autogain is disabled—either individually or by the Group Control—then the US Continuity Alarm will not be automatically re-enabled when US Autogain is re-enabled. A good way to ensure that the CMI US Continuity alarm is enabled in all CMIs is to select Enable All Alarms at the same time that the Enable US Autogain is selected in the CMI GROUP CONTROL dialog.

4.5.3 Acknowledging and Closing Alarms

When alarms occur, the dialog names and associated hardware icons flash and appear in a color indicating alarm criticality. For the purposes of this procedure, the color red is used, indicating critical failures. There are two methods used for viewing alarm messages: Unacknowledged alarms and Open alarms.

4.5.3.1 Unacknowledged Alarms

This procedure allows the user to review all unacknowledged alarm message(s) and any associated details. Acknowledging the individual alarm does not close the alarm but stops the display from flashing. The color that remains indicates the severity of the alarm.

- a. At the HEADEND CONTROL PANEL dialog, select **Alarms/Show Unacknowledged Alarms**. The UNACKNOWLEDGED ALARMS dialog appears. One or more alarm messages will appear in the dialog.
- b. Select (highlight) displayed alarm message to be reviewed.
- c. Click Review Details to view ALARM INFORMATION dialog. Upon completion of the review, click OK. The UNACKNOWLEDGED ALARMS dialog reappears.
- d. To acknowledge the alarm message, click Acknowledge and observe that selected alarm message is deleted from dialog.
- e. Click Cancel to return to the HEADEND CONTROL PANEL dialog.
- f. Observe that alarmed icon has stopped flashing but still displays in red.

4.5.3.2 Open Alarms

This procedure allows the user to review all open alarm message(s) and any associated details. Open alarms must be closed to return the active HIC to the color green. However, if an alarm is closed but not corrected, it will recur at the next polling interval.

- a. At the HEADEND CONTROL PANEL dialog, select **Alarms/Show Open Alarms** and observe that OPEN ALARMS dialog appears. One or more alarm messages will appear in the dialog.
- b. Select (highlight) displayed alarm message to be reviewed.
- c. Click Review Details to view ALARM INFORMATION dialog. Upon completion of the review, click OK. The OPEN ALARMS dialog reappears.
- d. To close the alarm message, click Close and observe that selected alarm message is deleted from dialog.
- e. Click Cancel to return to the HEADEND CONTROL PANEL dialog.
- f. Observe that icon color has changed to green.

4.6 REVIEWING AND UPDATING STATUS

4.6.1 HIC Status

To review the current operating parameters for an active HIC in either rack, use the HIC CONTROL PANEL dialog:

4.6.1.1 **HIC Updating Control Panel Status**

At the HIC CONTROL PANEL dialog, click Get Status to update status windows in HIC CONTROL PANEL dialog.

4.6.1.2 **HIC Administrative Status**

- a. At the HIC CONTROL PANEL dialog, click View Info and observe that HIC ADMINISTRATIVE DATA message appears.
- b. Observe current HIC reference data. The *Serial Number* and *Cell ID* fields may be modified here. Click OK to return to HIC CONTROL PANEL dialog.

4.6.1.3 **HIC Communications Statistics**

- a. At the HIC CONTROL PANEL dialog, click Comm Stats and observe that HIC COMMUNICATIONS STATISTICS dialog appears.
- b. Click Update Stats to update current data or Clear Stats to reset data to zero.
- c. Click OK to return to HIC CONTROL PANEL dialog.

4.6.1.4 **HIC Phase Lock Loop Status**

- a. At the HIC CONTROL PANEL dialog, click View Status and observe that HIC PLL STATUS dialog appears.
- b. Observe current PLL status for HIC. In normal operation, NO PLLs should be unlocked.
- c. Click Cancel to return to HIC CONTROL PANEL dialog.

4.6.2 CMI Status

To review the current operating parameters for an active CMI, use the HIC CONTROL PANEL and CMI CONTROL PANEL dialogs:

4.6.2.1 CMI Updating Control Panel Status

- a. At the HIC CONTROL PANEL dialog, double-click on desired CMI icon. The CMI CONTROL PANEL dialog appears.
- b. At the CMI CONTROL PANEL dialog, click Get Status to update status windows in CMI CONTROL PANEL dialog.

4.6.2.2 CMI Administrative Status

- a. At the HIC CONTROL PANEL dialog, double-click on desired CMI icon. The CMI CONTROL PANEL dialog appears.
- b. At the CMI CONTROL PANEL click View Info and observe that CMI ADMINISTRATIVE DATA message appears.
- c. Observe current CMI reference data. The *CMI Serial Number* and *CMI Location* fields may be modified here. Click OK to return to CMI CONTROL PANEL dialog.

4.6.2.3 CMI Communications Status

- a. At the HIC CONTROL PANEL dialog, select and double-click on appropriate CMI and observe CMI CONTROL PANEL dialog appears.
- b. At the CMI CONTROL PANEL dialog click Comm Stats and observe CMI COMMUNICATIONS STATISTICS dialog appears.
- c. Click Update Stats to update current data or Clear Stats to reset data to zero.
- d. Click OK to return to CMI CONTROL PANEL dialog.

4.6.2.4 CMI Phase Lock Loop Status

- a. At the HIC CONTROL PANEL dialog, double-click on desired CMI icon. The CMI CONTROL PANEL dialog appears.
- b. At the CMI CONTROL PANEL dialog, click View Status and observe that CMI PLL STATUS dialog appears.
- c. Observe current PLL status for CMI. In normal operation, no PLLs should be unlocked.
- d. Click Cancel to return to CMI CONTROL PANEL dialog.

4.7 SOFTWARE MAINTENANCE

4.7.1 HECU Database File Backup and Restore Procedures

These procedures provide instructions for making a backup copy of the database files contained within the HECU and for restoring the database from the backup files. These files are essential when performing a HECU "Restore Configuration" as they contain all the required restoration data. In the event of a system failure that prevents a proper restoration from the configuration files on the local HECU hard drive, it is possible to overwrite the corrupted files with a backup version saved earlier on a floppy disk.

4.7.1.1 Saving the Configuration

Prior to making a backup copy, it is first essential to have saved the desired configuration. If the desired configuration has not been saved, go to the HEADEND CONTROL PANEL dialog and select **Configuration/Save** from the menu bar.

4.7.1.2 Making the Backup Copy

- a. At HEADEND CONTROL PANEL dialog, press [ALT] [TAB] to switch to Windows™ **Program Manager**.
- b. From Windows Program Manager, select **Main Program Group**.
- c. From Main Program Group, select **File Manager**.
- d. At File Manager, locate the **c:\hec\db** directory.

Note

The c:\hec\db directory has 18 **Test1** database files, 18 **Test2** database files and a sub-directory titled **gold**, containing another 18 "gold" files. The files to be saved are the files starting with **Test2**.

- e. At File Manager, select all Test2*. * files in **c:\hec\db** directory. Note indicated byte count of selected files. If total size is less than 1,423 Kbytes, proceed to step *g*. If total size exceeds 1,423 Kbytes, continue with step *f*.
- f. At File Manager, select all Test2*.c and Test2*.h files in **c:\hec\db** directory. (This option will not restore the present alarm log data).
- g. Insert a 3 1/2 inch preformatted empty floppy disk into the A drive on HECU.
- h. At File Manager, **copy** all selected files to **A drive** by dragging them to A drive icon in upper left corner of display.
- i. After the copy operation is completed, close File Manager by pressing [ALT] [F4] or by using control box in upper left corner of File Manager window.
- j. Return to HEADEND CONTROL PANEL dialog by pressing [ALT] [TAB].
- k. Remove floppy disk from A drive. Label clearly, including date, and store in designated location.

4.7.1.3 Restoring From the Backup Copy

- a. Start HECU program. At CONFIGURATION OPTIONS dialog, select **No**.
- b. At HEADEND CONTROL PANEL dialog, select **Configuration/Save** from menu bar.
- c. Insert 3 1/2 inch backup floppy disk into A drive on HECU.
- d. If not at Windows Program Manager group, press [ALT] [TAB] to switch to Windows™ **Program Manager**.
- e. From Windows Program Manager, select **Main Program Group**.
- f. From Main Program Group, select **File Manager**.

- g. At File Manager, arrange two windows, one displaying drive C and the other displaying drive A.
- h. At File Manager, locate **c:\hec\db** directory.
- i. **Copy** entire backup disk to **c:\hec\db** directory by clicking the **a:** icon in left pane of A drive window and dragging it to **c:\hec\db** directory. This operation will overwrite all database Test2 files in **c:\hec\db** directory.
- j. After copy operation is completed, close File Manager by pressing **[ALT] [F4]** or by using control box in upper left corner of File Manager window.
- k. Shut down HECU program per paragraph 4.2.4, then restart program per paragraph 4.2.1. At CONFIGURATION OPTIONS dialog, select Yes.
- l. From the OPEN dialog, select any one of the test2*. * files displayed to load restored configuration. To confirm selection, click OK.
- m. Remove backup disk from A drive and store in designated location.

4.7.2 Software Download Procedures

The following procedures are provided for downloading new releases of CATV software from distribution diskettes. Procedures are given for:

- Remote Download via the Headend Control Unit (HECU)
- On-Site Download from laptop PC using RS-232 cable
- HIC download
- HECU download

In the following procedures, please note that downloading software to various CATV components may take up to 45 minutes. During downloads, the target units may be out of service for limited periods of time during autoresets.

4.7.2.1 Remote CMI Download Via HECU

4.7.2.1.1 Equipment and Supplies Required

The items required for the remote download procedure are listed below:

Item
One (1) Sanders CMI.HEX diskette (3 1/2-inch) containing file CMI.HEX

4.7.2.1.2 CMI.HEX File Transfer to HECU Hard Drive

- a. From the HEADEND CONTROL PANEL, press the [Alt]-[Tab] key combination as required to return to the Windows Program Manager.
- b. Insert the new CMI.HEX diskette into the HECU diskette drive.
- c. From the Windows Main Program Group, select File Manager. From File Manager, select Drive A.
- d. Using the File Manager, copy the program file CMI.HEX from the A:\ drive to the C:\HEC\BIN directory, overwriting any earlier version present.
- e. Close the File Manager and [Alt]-[Tab] back to the HEADEND CONTROL PANEL. The new CMI software is now stored in the HECU hard drive.

4.7.2.1.3 HECU Software Download to CMI

- a. Verify that the HEADEND CONTROL PANEL title bar reads HEADEND CONTROL PANEL: SUPER-USER. If it does not, increase privileges as follows:
 1. Select **Privileges** from the HEADEND CONTROL PANEL menu bar, then select **Increase Privileges** from the sub-menu.
 2. In the resulting HECU SYSTEM ACCESS dialog, type in the Super-User password and click on **OK**.
 3. Observe that the dialog title bar now reads HEADEND CONTROL PANEL: SUPER-USER.
- b. Select **Communications** from the HEADEND CONTROL PANEL menu bar, then select **Set Comm Params** from the sub-menu. In the resulting HECU-HIC COMMUNICATIONS dialog, ensure that the *Number of Retries* is set to 3. (If not, click on button next to 3.) Click on **OK**.
- c. At HEADEND CONTROL PANEL, double-click on icon of HIC that controls the target CMIs for the download.
- d. At the resulting HIC CONTROL PANEL, click on *CMI Group Ctl*.
- e. At the CMI GROUP CONTROL dialog, click the **Disable** buttons under *Autostats*, *DS Autogain* and *US Autogain*; under *Choose Sector(s)*, select all sectors that have CMIs attached. Click on **OK**.

NOTE

If autogain and autostats are not disabled, download time will be increased dramatically. While the autostats option is disabled for all CMIs controlled by the selected HIC, no CMI alarms will be reported to the HECU by that HIC.

- f. At the HIC CONTROL PANEL, double-click on the icon of the target CMI for the new software.
- g. At the CMI CONTROL PANEL, click on the *Download* button. A CODE DOWNLOAD CONTROL dialog will appear.
- h. In the box below *Enter Source Code filename*, type in the name of the file to be downloaded: CMI.HEX (see Figure 4-1). Click on **OK**.

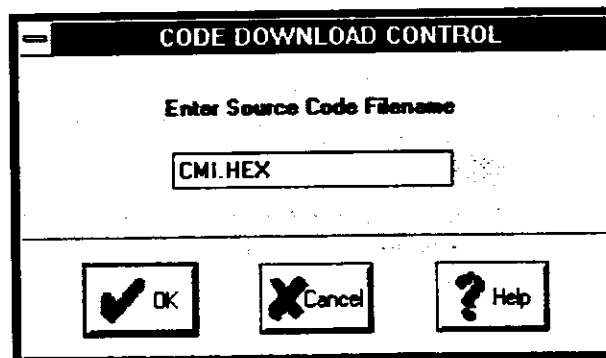

Figure 4-1. CMI Source Code Filename in CODE DOWNLOAD CONTROL Dialog

NOTE

The operating software expects the CMI.HEX file to be located on the hard drive in the c:\hec\bin directory. If the file is located in any other location then the full path and file name must be provided.

- i. The DOWNLOADING CODE dialog will appear as shown in Figure 4-2. The message will indicate which CMI is being downloaded and the percentage of completion. The example below shows software downloading to Alpha Sector CMI 5 on HIC 3 in the Main Rack.

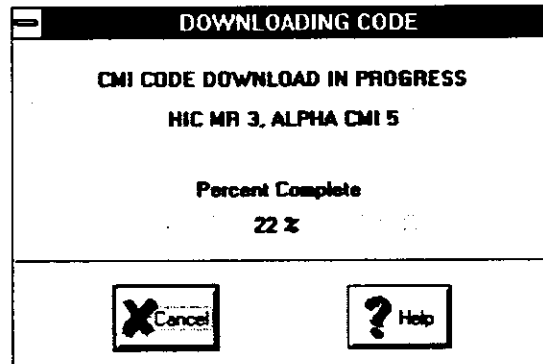

Figure 4-2. DOWNLOADING CODE Dialog

CAUTION

Once a CMI Code Download operation has begun, it **must be completed**. If the Cancel button on the download progress window is selected while the download is in progress, the aborted operation will leave the CMI firmware in a code download (non-communicating) state. Do not delete the CMI or shut off power to the CMI until the CMI has been properly downloaded. To restart a canceled download simply repeat the above steps.

- j. When *Percent Complete* reaches 100%, the DOWNLOADING CODE dialog will disappear, and the CMI will automatically reset. If Alarms are enabled on that CMI, a Device Reset alarm will occur at the next polling period. This alarm should be cleared by the operator.
- k. At the CMI CONTROL PANEL, click on the *Get Status* button to update the status of the target CMI. The software version displayed under *Configuration EEPROM SW*: should match the version printed on the label of the CMI.HEX distribution diskette. For example:

Configuration	
ROM SW	Ver 15
EEPROM SW	Ver 4
Hardware	Ver 1

- l. Download of the new software to the target CMI is complete. To download to another CMI, repeat this procedure starting at step f.
- m. After new software has been downloaded to all CMIs controlled by the same HIC, enable polling (autostats) on each CMI and the Autogain (if desired) using the CMI Group Ctl button on the HIC CONTROL PANEL dialog.

4.7.2.2 On-Site CMI Download using RS-232

4.7.2.2.1 Equipment and Supplies Required

The equipment and supplies required for the direct download procedure are listed below:

Item
• Sanders CMI.HEX diskette (3 1/2-inch) containing file CMI.HEX
• One (1) Sanders PC -> CMI DOWNLOAD diskette (3 1/2-inch) containing file SETUP.EXE
• Laptop PC with Windows 3.1 operating system
• RS-232 cable (see paragraph 4.7.2.4 for schematic)

4.7.2.2.2 Tools Required

The tools required for the direct download procedure are listed below:

Item
• Wrench, 1/2-inch hex socket for CMI Hinged Cover
• Wrench, torque (145 in-lb), 1/2-inch for CMI Hinged Cover

4.7.2.2.3 Installing PC -> CMI Download Program in the Laptop PC

To transfer the RS-232 PC -> CMI Download software from diskette to the laptop PC, perform the following steps:

- a. Set PC power switch to ON. If the Microsoft Windows Program Manager does not appear automatically, start it by typing **win** at the **C:\>** prompt and pressing the <ENTER> key.
- b. Insert PC -> CMI Download diskette into the A drive.
- c. Select **File, Run...** from the Program Manager menu bar. The RUN dialog appears.
- d. In the RUN dialog, type **a:\setup** in the Command Line window.
- e. Follow the resulting on-screen instructions.
- f. When file transfer is complete, remove installation diskette from the A drive.
- g. Insert diskette containing CMI.HEX file into the A:\ drive.
- h. Using File Manager copy A:\CMI.HEX to the C:\CMIDL directory.
- i. Remove diskette containing CMI.HEX file from the A:\ drive.

4.7.2.2.4 Preparing the Network Control and Monitoring Software

Before positioning the maintenance bucket and opening the CMI for software downloading, contact the Headend or NOCC network operator, as applicable, and verify that the control and monitoring options have been set for the target CMI as follows:

- a. Disable the following options at the TRANSCEIVER CONTROL dialog:
 - DS Autogain
 - US Autogain
 - Autostat
 - Power Amp
- b. To save the upstream power settings at the CMI UPSTREAM POWER dialog, select Save to EEPROM button then click OK.
- c. To save the downstream power settings, at the CMI DOWNSTREAM POWER dialog, perform the same actions as in the previous step.
- d. Exit the CMI CONTROL PANEL for the target CMI.

NOTES

Disabling the autogain and autostats prevents the HECU from talking to the CMI while it is being downloaded and prevents the CMI from alarming.

Saving the Upstream and Downstream Power levels prevents the HECU from using default settings when re-acquiring the CMI.

4.7.2.2.5 CMI Preliminary Checks

- a. Open CMI cover per paragraph 5.4.1.1.
- b. Ensure that power is applied to the CMI Transceiver module by observing that the green LED on the top of the module is lit.

4.7.2.2.6 Downloading New CMI Software With PC -> CMI Download

NOTE

Take care not to touch the keyboard of the laptop PC while the download is in progress. *Pressing any key will abort the download.*

Once the download process has started, the CMI **will not respond** to messages originated by the HIC/HECU until it has completed the download process.

- a. Enter Microsoft Windows.
- b. Open the program group labeled PC -> CMI Download.
- c. Double click the Icon labeled PC -> CMI Download. The PC -> CMI Download dialog will appear (Figure 4-3).

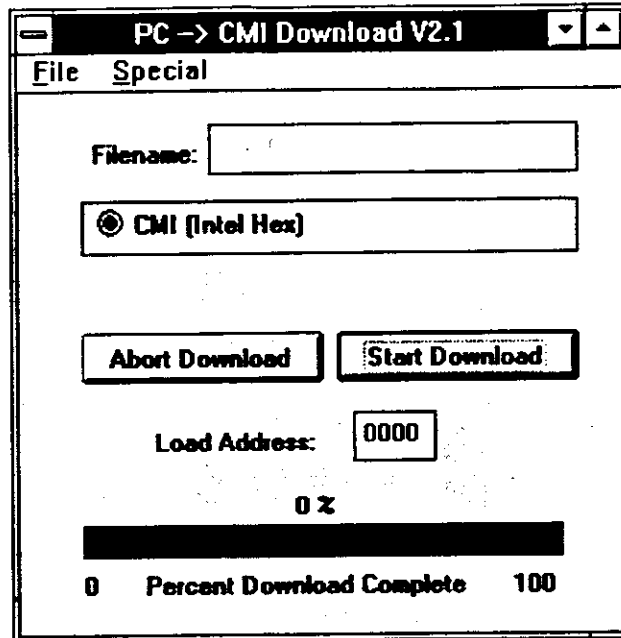

Figure 4-3. PC -> CMI Download Dialog

- d. Connect the 9 pin “D” connector of the RS-232 cable to Comm Port 1 of the PC being used. (See Section 4.7.2.4 for Cable information.)
- e. Connect the 15 pin “D” connector of the RS-232 cable to the test connector on the CMI transceiver to be downloaded. (See Figure 4-4.)

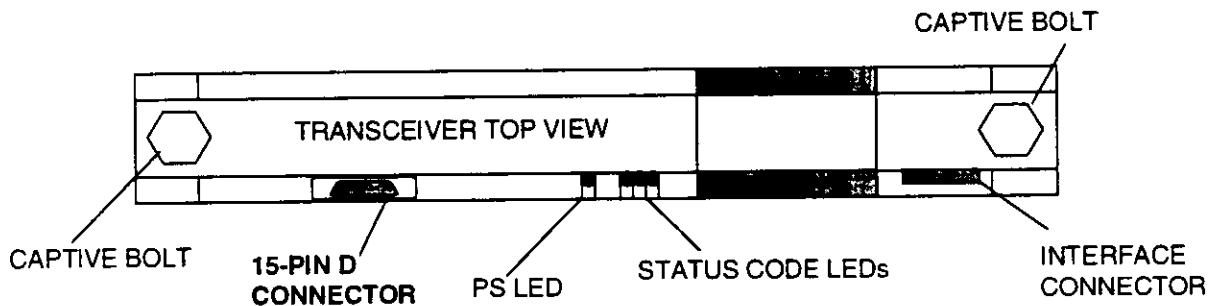

Figure 4-4. Transceiver Connector Location

- f. At the PC -> CMI Download dialog, press the Start Download button.
- g. A message to read the CMI’s software version number will be sent. The response message will appear as shown in Figure 4-5. If the version number is an older revision than what is to be downloaded, press the Proceed with Download button, and the CMI transceiver will be loaded with the new software. Should the message show that the CMI already has the latest software version, the download may be stopped by pressing the ABORT Download button. If the download is aborted, there will be no change to the CMI transceiver’s software.

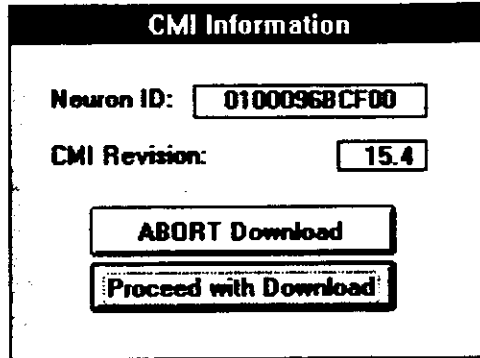

Figure 4-5. CMI Information Dialog with Download Options

- h. The top-level PC -> CMI Download dialog will reappear, and the status bar at the bottom of the dialog will indicate download progress.
- i. When the software download to the CMI is complete, a "SUCCESSFUL DOWNLOAD" message will appear (Figure 4-6). Click the OK button to return to the main PC -> CMI Download V2.0 dialog.

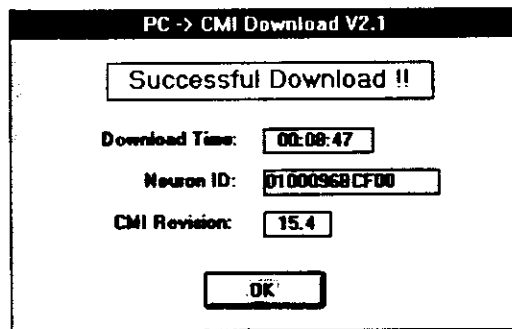

Figure 4-6. Successful Download Message

- j. If a message is displayed on the PC indicating a problem with the download, refer to paragraph 4.7.2.3, CMI Download Troubleshooting.
- k. If you need to download another CMI, move the RS-232 cable to the next CMI transceiver and repeat this procedure from Step f. Otherwise select **File, Exit** from the menu bar to exit the PC -> CMI Download program.

4.7.2.2.7 Returning the CMI to Service

CAUTION

Failure to properly secure the CMI cover may allow moisture to enter the CMI chassis, causing performance problems and possible hardware damage.

- a. Close CMI cover per paragraph 5.4.1.2.
- b. Contact the HECU/NOCC operator and advise that the CMI is ready for re-acquisition.

NOTES

At the end of the download, the CMI will reset to whatever state was selected (Last Value or Defaults) when the CMI was last acquired or last reset.

If the CMI is not acquired by the HIC/HECU, at the end of download it will reset to defaults. To restore last values the CMI will need to be reset to "Last Value" immediately after acquisition.

- c. The HECU/NOCC operator will open the CMI CONTROL PANEL for the target CMI and click on the *Get Status* button to update the status of the target CMI. The software version displayed under *Configuration EEPROM SW:* should match the version printed on the label of the CMI.HEX distribution diskette.
- d. The HECU/NOCC operator will check the Upstream and Downstream power levels and change any that are not correct.
- e. The HECU/NOCC operator will re-enable the following control and monitoring options, as desired:
 - DS Autogain
 - US Autogain
 - Autostat
 - Power Amp
- f. The HECU/NOCC operator will advise the technician at the CMI that the target CMI as been returned to service.

4.7.2.3 CMI Download Troubleshooting

If a download message fails to be accepted by a CMI transceiver, a Message Response Timeout dialog will appear (Figure 4-7):

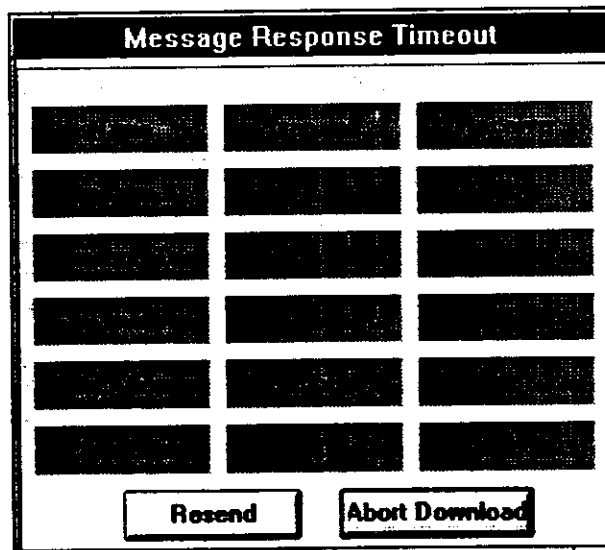

Figure 4-7. Message Response Timeout Dialog

- a. First, click on Resend. Occasionally, random environmental noise will cause a transmission error, and sending the message packet once more may clear the problem.
- b. If Resend does not clear the problem, click on Abort Download and check for other probable causes. Probable causes and recommended corrective actions are listed in Table 4-2:
- c. If none of the above probable causes of download failure appear to be valid, replace the CMI Transceiver module.

4.7.2.4 RS-232 Download Cable Requirements

Figure 4-8 is the schematic diagram for the RS-232 Download cable. It connects between the COMM1 RS-232 port on a laptop or desktop PC and the test connector on the CMI's Transceiver module. When constructing this cable, follow these guidelines for the best results:

- a. The RS-232 (EIA-232) specification allows cable lengths in excess of 40 feet. However, to ensure maximum noise immunity, cable length should be kept to a minimum.
- b. Ensure that a ground wire is included in the cable and connected as shown in the schematic.
- c. Use the heaviest gauge wire that the connectors will accommodate.
- d. The two signal lines, RX_IN and RS232_TX, should be a twisted pair. Even better noise immunity will result from combining all three wires in a triple twisted configuration.

Table 4-2. CMI Download Troubleshooting Table

Probable Cause	Recommended Corrective Action
The RS-232 cable is not connected properly between PC and CMI transceiver	Check that 9-pin "D" is connected to Comm Port 1 of the PC and 15 pin "D" is connected to the test port on the CMI transceiver.
The RS-232 cable is not built properly.	Check the cable against the schematics included in section 4.7.2.4. Ensure that ground is included in the cable (a battery powered laptop will not provide a return ground path).
The CMI has received messages via the HECU and via the test port and has corrupted the RS-232 communications.	Cycle power on the CMI.
If the CMI.HEX file is not copied into the C:\CMIDL directory, a pop-up message will notify the user that the program couldn't find the file and the program will terminate	Copy the CMI.HEX file into the C:\CMIDL directory to correct this problem.

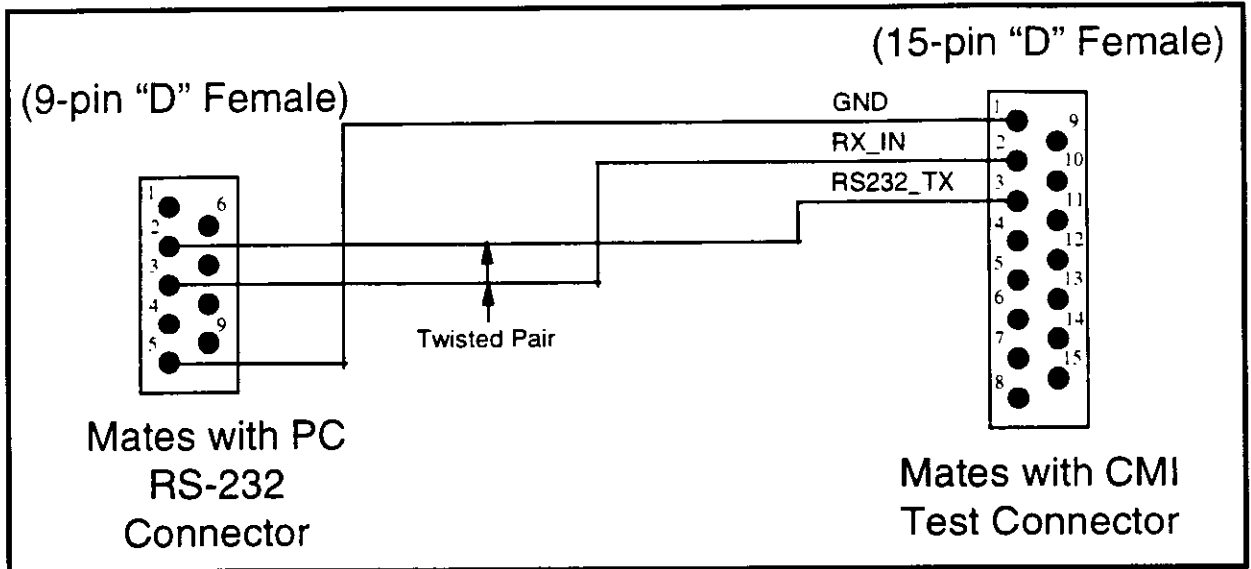

Figure 4-8. RS-232 Download Cable Schematic Diagram

4.7.2.5 HIC Software Download from the HECU

4.7.2.5.1 Equipment and Supplies Required

The items required for the HIC download procedure are listed below:

Item
One (1) Sanders diskette (3 1/2-inch) containing file HIC_HEC.P

4.7.2.5.2 HIC_HEC.P File Transfer to Hard Drive

- a. From the HEADEND CONTROL PANEL, press the [ALT]-[TAB] key combination as required to return to the Windows Program Manager.
- b. • Insert the new program code diskette into the HECU floppy drive.
- c. From the Windows Main Program Group, select File Manager and select Drive A.
- d. Copy the program file **HIC_HEC.P** from the A Drive to the **C:\HEC\BIN** directory, overwriting any earlier version present.
- e. Close the File Manager and [ALT]-[TAB] back to the HEADEND CONTROL PANEL.

4.7.2.5.3 HECU Software Download to HIC

- a. Verify that the HEADEND CONTROL PANEL title bar reads HEADEND CONTROL PANEL: SUPER-USER. If it does not, increase privileges as follows:
 1. Select **Privileges** from the HEADEND CONTROL PANEL menu bar, then select **Increase Privileges** from the sub-menu.
 2. In the resulting HECU SYSTEM ACCESS dialog, type in the Super-User password and click on **OK**.
 3. Observe that the dialog title bar now reads HEADEND CONTROL PANEL: SUPER-USER.

- b. Select **Communications** from the HEADEND CONTROL PANEL menu bar, then select **Set Comm Params** from the sub-menu. In the resulting HECU-HIC COMMUNICATIONS dialog, ensure that the *Number of Retries* is set to 3. (If not, click on button next to 3.) Click on OK.
- c) At the HEADEND CONTROL PANEL, double-click on the icon of the target HIC for the new software.
- d. At the HIC CONTROL PANEL, click on the *Download* button. A CODE DOWNLOAD CONTROL dialog will appear.
- e. In the box below *Enter Source Code filename*, type in the name of the file to be downloaded: HIC_HEC.P (see Figure 4-9). Click on OK.

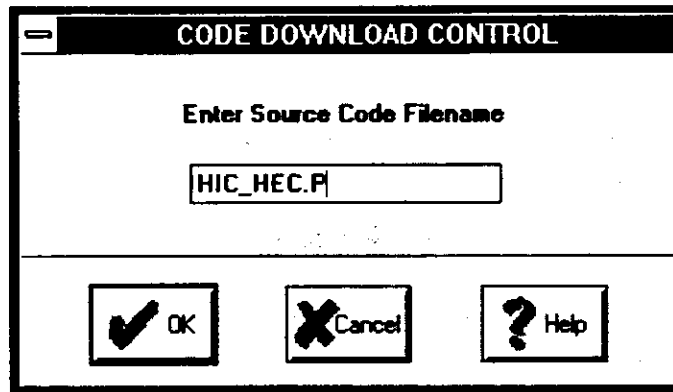

Figure 4-9. HIC Source Code Filename in CODE DOWNLOAD CONTROL Dialog

- f. The DOWNLOADING CODE message will appear as shown in Figure 4-10. The window will indicate which HIC is being downloaded and the percentage of completion. The example below shows code downloading to HIC 5 in the Main Rack. During this download process the FAULT LED on the selected HIC will be ON.

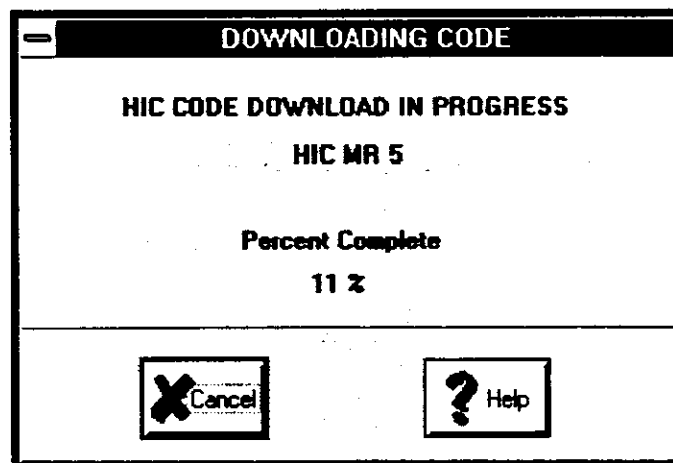

Figure 4-10. Typical DOWNLOADING CODE Message for HIC

CAUTION

Once a HIC Code Download operation has begun, it **must be completed**. If the Cancel button on the download progress window is selected while the download is in progress, the aborted operation will leave the HIC firmware in a code download (non-communicating) state. Do not delete the HIC or shut off power to the HIC until the HIC has been properly downloaded. To restart a canceled download simply repeat the above process.

- g. When the *Percent Complete* reaches 100%, the Download window will disappear, the HIC will automatically reset, and the HIC FAULT LED will extinguish. A "Device Reset" alarm will occur at the next polling period. This alarm should then be cleared by the operator.
- h. At the HIC CONTROL PANEL, click on the *Get Status* button to update the status of the target HIC.
- i. Click on the *View Info* button to view the revision of the new software just downloaded and confirm that it matches the version number on the distribution diskette label.
- j. Download of the new software to the target HIC is complete. To download to another HIC, repeat this procedure starting at step c.
- k. After new software has been downloaded to all HICs controlled by the HECU, enable the polling (autostats) on each CMI and enable the Autogain (if desired). The CMI Group Ctl button on the HIC CONTROL PANEL can be used for this purpose.

4.7.2.6 HECU Software Download

CAUTION

All files installed on the hard drive and not related to the PCS-Over-Cable system must be removed prior to the software installation.

Before downloading, verify that all HICs are at the proper software revision for compatibility with the new HECU software. If the HIC software is not at the proper revision, the HICs may not understand the messages sent by the updated HECU software. This will lead to unpredictable results and render the system out of service.

4.7.2.6.1 Equipment and Supplies Required

The items required for the HECU download procedure are listed below:

Item
Four (4) Sanders diskettes (3 1/2-inch) labeled HECU SOFTWARE INSTALLATION

4.7.2.6.2 ***HECU Software Transfer to HECU CPU Hard Drive***

- a. Verify that HEADEND CONTROL PANEL title bar reads HEADEND CONTROL PANEL: SUPER-USER. If it does not, increase privileges as follows:
 1. Select **Privileges** from HEADEND CONTROL PANEL menu bar, then select **Increase Privileges** from sub-menu.
 2. In the resulting HECU SYSTEM ACCESS dialog, type in Super-User password and click on **OK**.
 3. Observe that dialog title bar now reads HEADEND CONTROL PANEL: SUPER-USER.
- b. If current system configuration data has not been saved, save it now using HEADEND CONTROL PANEL **Configuration/Save** menu option.
- c. Close HEADEND CONTROL PANEL dialog to shut down the HECU operating software, leaving all HICs and CMIs attached and operating.
- d. As a precaution, save all of the Test1*.* and Test2*.* configuration data files in the **c:\hec\db** directory to a diskette using Windows File Manager.
- e. Using Windows File Manager, determine whether the directory **c:\hec\temp** exists, and create it if it does not.
- f. At Windows Program Manager, if **PCS Program Group** does not contain HECU Icon, delete **PCS Program Group**.
- g. If **StartUp Program Group** does not contain HECU Icon, delete **StartUp Program Group**.
- h. Insert Disk #1 into A drive.
- i. Select **"File, Run..."** from Program Manager menu bar.
- j. In pop-up RUN dialog, type "A:\INSTALL" in Command Line window.
- k. Follow on-screen instructions. Installation program will prompt for Disks #2, #3 and #4 in order, followed by Disk #1 again. If this sequence does not occur, installation should be considered suspect: Exit and restart from Disk one.
- l. When prompted to reboot Windows, select **Yes**.
- m. When Windows reboots, HECU program will be started automatically.
- n. When prompted by CONFIGURATION OPTIONS dialog, select **Yes**, then select any one of the Test2*.* files displayed in the resulting OPEN dialog.
- o. When prompted by INITIALIZATION OPTIONS dialog, select **NO**.
- p. When HEADEND CONTROL PANEL is displayed, select **Help/About HECU** from menu bar and verify that HECU Software Revision on first line of ABOUT HECU SOFTWARE message matches revision on label of distribution diskettes.

4.7.3 **HECU Software System Verification**

- a. At HEADEND CONTROL PANEL, double click on a green (active) HIC.
- b. At HIC CONTROL PANEL dialog, select **View Info** and verify that correct HIC software is installed. Close HIC ADMINISTRATIVE DATA dialog by clicking **OK**.

- c. At HIC CONTROL PANEL dialog, select the first active CMI in Alpha Sector. When CMI CONTROL PANEL: ALPHA SECTOR, CMI [x] is displayed, verify that the correct software data is shown for the CMI in the *Configuration* box and that CMI is operating by checking the status of *Transceiver Parameters*.
- d. Repeat above steps for all operating HICs. When complete, notify the NOCC that download is complete and system is fully restored.

4.8 RESET

4.8.1 HIC Reset

The HIC RESET CONTROL dialog (Figure 3-47) permits selection of which set of parameters are used by the HIC after either a power-on reset or a soft reset. Note that by selecting **OK**, a soft reset is actually performed. The preferred recovery state after a HIC power interruption is Last Value. Therefore, if a HIC is reset to Defaults, it is important to (1) save any subsequent attenuator changes and (2) reset the CMI to Last Value, to ensure the proper power-up reset values for any subsequent unattended power interruption and recovery. Table 4-3 lists the HIC default reset values.

- a. At the HIC CONTROL PANEL dialog, click **Reset** and observe that HIC RESET CONTROL dialog appears.
- b. At *Choose Values To Use On Reset*, select either Defaults or Last Value.
- c. Click **OK** to return to HIC CONTROL PANEL dialog.

NOTE

After a reset to default values, the HIC will come up with the Downstream Power Output, Reference Tone, and Control Tone disabled. This condition will cause a DS Power Range Error alarm and a HIC Reset alarm.

Table 4-3. HIC Default Reset Values

Default Attenuator Values		Default Frequencies	
Alpha Upstream Primary	22 dB	Downstream	Ch. 62
Alpha Upstream Diversity	22 dB	Alpha Upstream Primary	6 MHz
Beta Upstream Primary	22 dB	Alpha Upstream Diversity	8 MHz
Beta Upstream Diversity	22 dB	Beta Upstream Primary	10 MHz
Gamma Upstream Primary	22 dB	Beta Upstream Diversity	12 MHz
Gamma Upstream Diversity	22 dB	Gamma Upstream Primary	14 MHz
Alpha Downstream	22 dB	Gamma Upstream Diversity	16 MHz
Beta Downstream	22 dB	PCS Channel	25
Gamma Downstream	22 dB	Default Modes	
Reference & Control	20 dB	DS Output	Enabled
		Reference Tone	Enabled
		Control Tone	Enabled

4.8.2 CMI Reset

The CMI RESET CONTROL dialog (Figure 3-59) permits selection of which set of parameters are used by the CMI after either a power-on reset or a soft reset. Note that by selecting OK, a soft reset is actually performed. The preferred recovery state after a CMI power interruption is Last Value. Therefore, if a CMI is reset to Defaults, it is important to (1) save any subsequent attenuator changes and (2) reset the CMI to Last Value, to ensure the proper power-up reset values for any subsequent unattended power interruption and recovery. Table 4-4 lists the CMI default reset values.

- a. At the CMI CONTROL PANEL dialog, click Reset and observe that CMI RESET CONTROL dialog appears.
- b. At *Choose Values To Use On Reset*, select either Defaults or Last Value.
- c. Click OK to perform soft reset and return to CMI CONTROL PANEL dialog.

NOTE

For proper system operation, the US Autogain and DS Autogain must be Disabled prior to resetting the CMI. After the reset has occurred and the CMI Upstream attenuators reflect the new values (either default or last values), then the CMI UPSTREAM POWER dialog must be selected, the attenuator values changed if desired, and the OK button selected; regardless of whether the attenuators were changed or not. This must be performed prior to re-activating autogain to ensure that the upstream attenuators maintain the new (reset) value.

Table 4-4. CMI Default Reset Values

Default Attenuator Values	
Upstream Power-Primary Attenuation	4.0 dB
Upstream Power-Diversity Attenuation	4.0 dB
Upstream Power-Combined Attenuation	44 dB
Upstream Power-Control Attenuation	20 dB
Downstream Power-Downstream Attenuation	54.0 dB
Default Transceiver States	
Transmitter	Disabled
Primary Receiver	Disabled
Diversity Receiver	Disabled

SECTION 5 MAINTENANCE AND TROUBLESHOOTING

5.1 SCHEDULED MAINTENANCE

5.1.1 HECU Computer Dust Filter

The dust filter should be cleaned and/or replaced periodically to ensure that the computer has adequate air flow for ventilation; frequency depends on the HECU operating environment. Service the dust filter as follows:

- a. Loosen captive screws that secure protective panel to computer front panel.
- b. Remove dust filter retaining guard from protective panel.
- c. Lift dust filter away from protective panel.
- d. Gently wash dust filter with mild soapy water, rinse clean and let dry. If dust filter is torn or damaged, obtain similar filter stock and cut out a replacement dust filter.
- e. Position dust filter in protective panel and secure dust filter with dust filter retaining guard.
- f. Position protective panel over the computer front panel, ensuring that 3.5-inch disk drive fits through cutout in protective panel. Tighten captive screws.

5.1.2 HIC Dust Filter

The dust filter should be cleaned and/or replaced periodically to ensure that the HIC has adequate air flow for ventilation; frequency depends on the HIC operating environment. Refer to Figure 5-1 for the following service procedure:

- a. Position a small screwdriver near key (1) between filter holder (2) and filter guard (3).
- b. Gently twist screwdriver to spread outer edge of filter holder (2) moving key (1) so that filter guard (3) is able to slip away from filter holder (2).
- c. Remove filter guard (3) from filter holder (2).
- d. Separate dust filter (4) from filter holder (2).
- e. Gently wash dust filter (4) with mild soapy water, rinse clean and let dry. If dust filter is torn or damaged, obtain similar filter stock and cut out a replacement dust filter.
- f. Position dust filter (4) in filter holder (2), and secure dust filter (4) with filter guard (3). Ensure the key (1) fits over filter guard (3).

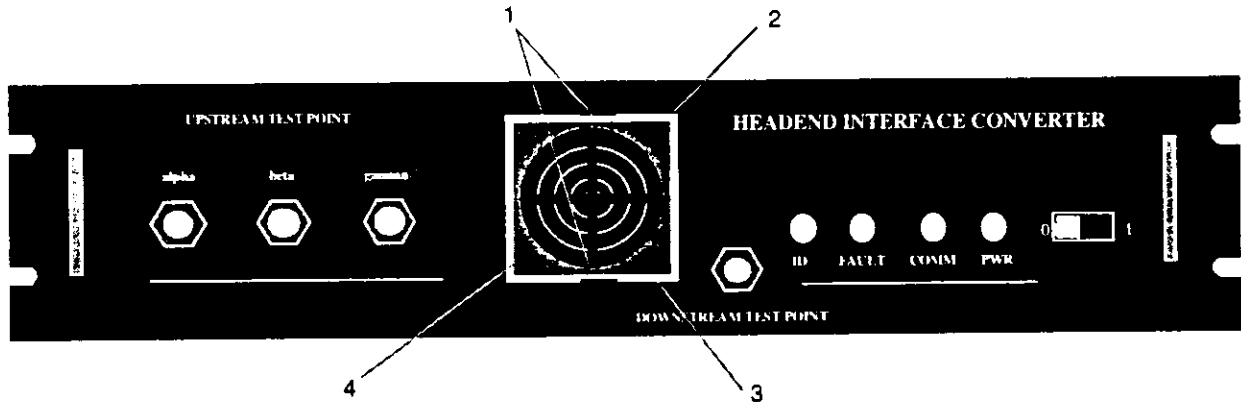

Figure 5-1. HIC Dust Filter

5.1.3 HIC BTS/CATV Connectors

ALL HIC BTS and CATV interface connections should be checked periodically to ensure that they are tight. Poor connections can cause additional signal loss, external interference or degradation of signal quality.

5.2 INSTALLATION OF OPTIONAL INTERNAL POWER SUPPLY

After initial installation, if circumstances change such that an external +24V power source is no longer available to the HEE racks, an optional internal +24V Power Supply, part number 8303743G1, may be installed in the primary and/or expansion racks. Paragraphs 5.2.1 and 5.2.2 give the installation instructions.

5.2.1 Rack Modification for +24V Power Supply Installation

Table 5-1 lists the parts required for the rack conversion.

Table 5-1. Power Supply Assembly

Item	Part Number	Quantity
24 Vdc Power Supply	8303743G1	1
Cable Assembly +24 Vdc Pwr Supply Out	8331058G1	1
Cable Assembly Power Supply (AC In)	8303740G1	1
Filler Panel	FP19-1.75 Black	1

- a. Remove and store the two uppermost blank panels located on the front of the equipment rack.

NOTE

The blank panels, angle brackets, and adjustable clamps should be retained at the installation site. The parts will be needed to reconvert the rack for +24V external power input. The angle brackets will be needed for the two previously unavailable HIC positions.

- b. Using a 3/8-inch wrench, remove and store the top pair of rack angle brackets.

- c. Remove and store the four adjustable clamps located within the vertical channels.
- d. Loosen the four bolts holding the second pair of angle brackets sufficiently to move the brackets.
- e. Align the top of the loosened brackets to the top of the highest remaining blank panel.
- f. Level the brackets using a tape measure, ensuring the distance from the front of the bracket to the next lowest bracket is the same as the rear.
- g. Tighten the bolts on the two brackets.
- h. Add the FP19-1.75B Black filler panel to the rack at the location just below the ISOBAR® Surge Suppressor.
- i. Secure the panel using two 10-32 x 0.50 mounting bolts and washers.

5.2.2 +24V Power Supply Installation (8303743G1)

- a. Loosen the two screws and washers that secure Plexiglas protector over power input terminal board.
- b. Connect Power Supply Input Cable 8303740G1 to the terminal block located at the rear of the power supply as follows:
 - Black wire to the Line AC input (L1) of the terminal block.
 - White wire to the Neutral AC input (L2) of the terminal block.
 - Green wire to the GND input of the terminal block.
- c. Install Plexiglas protector over power input terminal board and secure with the two screws and washers.
- d. Loosen the two screws and washers that secure Plexiglas protector over V1 (+) and (-) terminals.
- e. Connect Power Supply Output Cable 8331058G1 to the V1 (+) and (-) terminals using the provided 1/4 inch hardware. Verify the polarity of the wires before connecting.
- f. Install Plexiglas protector over V1 (+) and (-) input terminal board and secure with the two screws and washers.
- g. Position and install the +24V Power Supply into the rack on the angle brackets just below the ISOBAR® Surge Suppressor. Adjust the angle brackets if necessary, and tighten the bolts securing the brackets.
- h. Secure the +24V Power Supply to the rack using four 10-32 x 0.50 screws and washers.
- i. Plug the 3-prong Power Supply Input Cable connector into one of the white ISOBAR® Surge Suppressors (75 dB) outlets.

5.3 PRIMARY/EXPANSION RACK ASSEMBLY/DISASSEMBLY INSTRUCTIONS

5.3.1 Surge Suppressor Replacement Procedure

This procedure contains instructions for removing a defective ISOBAR® Surge Suppressor and installing a replacement.

WARNING

The voltages and current levels present in the rack are potentially lethal. This procedure requires work inside the rack. Use extreme caution to avoid coming into contact with the 115 Vac at the Prime Power Panel or the +24V on the 24 VDC bus bar. Whenever possible, disconnect the 115 Vac and +24V power inputs to the rack.

CAUTION

Removal of +24V input to HICs will cause all HICs to be inoperative during this procedure.

- a. Set the 115 Vac power switch to OFF (located at top of rack on the ISOBAR® Surge Suppressor).
- b. Disconnect 115 Vac ISOBAR® power cable from power source.
- c. Loosen and remove the four bolts and washers that secure the surge suppressor to the rack.
- d. Gently pull the surge suppressor forward to gain access to its rear outlets. (Assemblies requiring 115 Vac are installed with at least a six-inch service loop on the ac power cords to aid in surge suppressor replacement).
- e. Disconnect the individual 115 Vac power cables from the surge suppressor.
- f. Guide the surge suppressor power cable over the rack cable bundles and out through the front of the rack.
- g. Package and return defective surge suppressor to the seller for disposition.
- h. Guide the replacement ISOBAR® Surge Suppressor power cable from the front of the rack, over the cable bundles, and out of the rear of the rack.
- i. With the surge suppressor unsecured, connect the 115 Vac power cables of the individual assemblies to the surge suppressor rear outlets.
 - Connect the +24V Power Supply power cable (if applicable) to a white outlet. Connect all other cables to a dark colored outlet.
 - Ensure that each assembly power cord has at least a six-inch service loop to aid in future surge suppressor replacement without removing installed HICs.
- j. Position and secure replacement surge suppressor using four mounting bolts and washers.
- k. Set the +115 Vac switch to ON at the rack ISOBAR® Surge Suppressor.
- l. Return rack to normal operation.

5.3.2 Headend Control Unit (HECU) Replacement Procedure

Normally, the HECU will not be replaced as a unit. The replacement procedures for the HECU consists of instructions for replacing defective HECU components. The major HECU components that may require replacement are:

- Computer
- Monitor
- Keyboard
- Mouse

NOTE

Individual components of the HECU have a two (2)-year warranty. Any attempt to repair and/or break the seal to gain access to the internal subassemblies of a HECU component will void the warranty for the component. During the warranty period, a suspected defective HECU component should be returned to the seller for replacement or repair.

5.3.2.1 *Computer Replacement Procedure*

This procedure contains instructions for removing a defective HECU computer and installing a replacement unit.

NOTE

During computer replacement, the HIC/CMI system will continue normal operation, but any HIC or CMI alarms will not be detected and reported by the HECU. If the HECU watchdog timer is connected to a remote monitoring site, that site should be notified before performing this procedure.

Individual components of the HECU have a two-year warranty. Any attempt to repair and/or break the seal to gain access to the internal subassemblies of a HECU component will void the warranty for the component. During the warranty period, a suspected defective HECU component should be returned to the seller for replacement or repair.

- a. Prior to exiting the HECU operating program, if possible, save the current configuration.
 - 1) At HEADEND CONTROL PANEL dialog, select **Configuration/Save** option on menu bar.
 - 2) After selecting **Save** command, wait approximately 30 seconds for configuration files to be saved to **c:\hec\db** directory.
 - 3) Make a Database Backup File per paragraph 4.7.1.2.

- b. Shut down HECU operating program (see Section 4), and set computer power switch to OFF.

WARNING

The voltages and current levels present in the rack are potentially lethal. This procedure requires work inside the rack. Use extreme caution to avoid coming into contact with the +24V at the Prime Power Panel or on the 24 VDC bus bar.

- b. At the Computer rear panel (Figure 5-2), disconnect all cables from the rear of the chassis.
- c. At the front of the rack, loosen and remove four screws that secure computer to rack.
- d. Gently slide computer out from rack and set aside for shipment to repair facility.
- e. At the front of the replacement computer, remove the hardware from the bracket mounting holes on the left and right sides.
- f. Using removed hardware, attach the two replacement brackets provided with the replacement computer to the chassis and tighten.
- g. Slide replacement computer into front of rack on rack angle rails.
- h. Secure replacement computer to rack with four mounting screws and washers.
- i. At the computer rear panel (Figure 5-2), connect the following:
 - 115 Vac power cable to AC input connector
 - Monitor cable to Video connector
 - Mouse cable to Mouse connector
 - Keyboard cable to Keyboard connector
 - Watchdog timer cable to WDT connector
 - HIC communication cable to RS-485 connector
 - NOCC Interface Connectors (If Applicable)
- j. Ensure HECU Computer is turned on and the power indicator is lit.
- k. Restore configuration from Backup copy per paragraph 4.7.1.3. If no backup was made, all devices must be individually re-acquired.

NOTE

If the HECU watchdog timer is connected to a remote monitoring site, that site should be notified after completing this procedure.

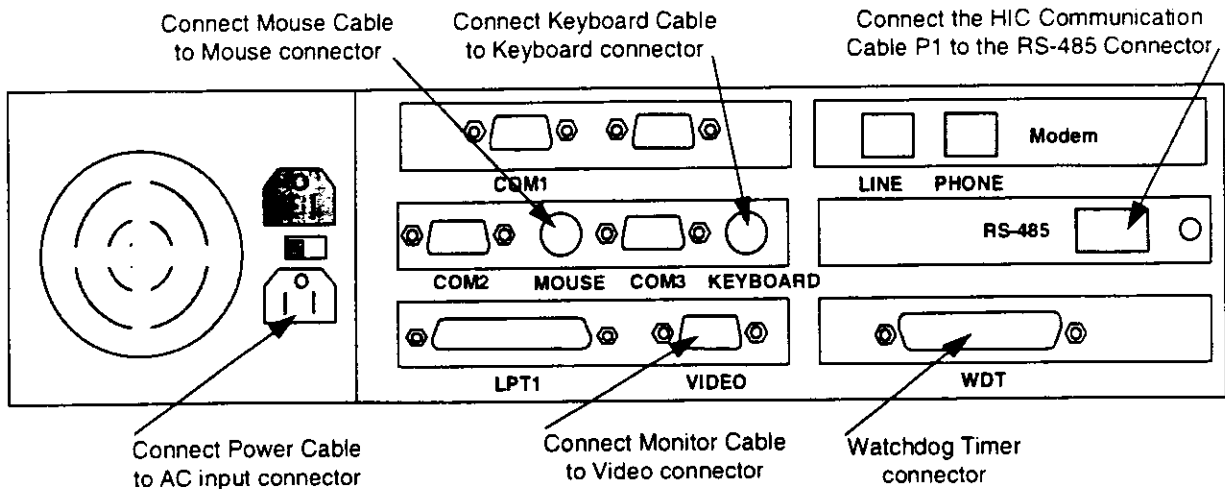

Figure 5-2. HECU Computer Rear View

5.3.2.2 Monitor Replacement Procedure

This procedure contains instructions for removing a defective HECU monitor and installing a replacement unit.

NOTE

During monitor replacement, the HIC/CMI system will continue normal operation, but any HIC or CMI alarms will not be detected and reported by the HECU. If the HECU watchdog timer is connected to a remote monitoring site, that site should be notified before performing this procedure.

Individual components of the HECU have a two (2)-year warranty. Any attempt to repair and/or break the seal to gain access to the internal subassemblies of a HECU component will void the warranty for the component. During the warranty period, a suspected defective HECU component should be returned to the seller for replacement or repair.

- a. Without shutting down the HECU Software, Set the monitor and HECU computer power switches to OFF.

WARNING

The voltages and current levels present in the rack are potentially lethal. This procedure requires work inside the rack. Use extreme caution to avoid coming into contact with the +24V at the Prime Power Panel or on the 24 VDC bus bar.

- b. Set the monitor power switch to OFF.
- c. At the monitor rear panel, disconnect:

- 115 Vac power cable from Monitor connector
 - Monitor cable from Computer VIDEO connector
- d. At the front of the rack, loosen and remove eight screws that secure monitor to rack.
 - e. Gently slide monitor out of rack and set aside for shipment to repair facility.
 - f. While supporting front and back of the replacement monitor, carefully insert the monitor into front of the rack.
 - g. Secure monitor to rack using eight mounting screws and washers.
 - h. Connect monitor video cable to the Video connector on the rear of computer.
 - i. Using long tie wraps, bundle any excess monitor cable.
 - j. Connect the monitor power cable to the monitor ac input connector.
 - k. Turn on Monitor and HECU Computer and wait for them to sequence through initialization routines.
 - l. The HECU program will automatically restart with the HICs and CMIs at their last state.

NOTE

If the HECU watchdog timer is connected to a remote monitoring site, that site should be notified after completing this procedure.

5.3.2.3 Keyboard Tray Replacement Procedure.

This procedure contains instructions for removing a defective keyboard and installing a replacement unit. The replacement keyboard is provided with the replacement Keyboard Tray, and the entire tray is replaced. The keyboard is unique in size and should not be replaced separately. Refer to Figure 5-3 for the tray replacement procedure.

WARNING

The voltages and current levels present in the rack are potentially lethal. This procedure requires work inside the rack. Use extreme caution to avoid coming into contact with the +24V at the Prime Power Panel or on the 24 VDC bus bar.

NOTE

During keyboard replacement, the HIC/CMI system will continue normal operation, but any HIC or CMI alarms will not be detected and reported by the HECU. If the HECU watchdog timer is connected to a remote monitoring site, that site should be notified before performing this procedure.

NOTE

Individual components of the HECU have a two-year warranty. Any attempt to repair and/or break the seal to gain access to the internal subassemblies of a HECU component will void the warranty for the component. During the warranty period, a suspected defective HECU component should be returned to the seller for replacement or repair.

- a. Without shutting down the HECU Software, set computer power switch to OFF.
- b. At rear of rack, remove all tie wraps securing keyboard and mouse cables.
- c. Disconnect mouse cable from computer and keyboard cable from adapter cable.
- d. At front of rack, pull keyboard tray fully forward until tray locks.
- e. Remove mouse from tray.
- f. Press locking tab and pull tray forward to disengage tray from rack.
- g. Detach Keyboard Tray from slide rails by removing five 10-32 brass screws on each side.
- h. Attach right slide rail to the right side of replacement keyboard tray using five of the 10-32 brass-plated screws.
- i. Repeat step *h* for the left side of replacement keyboard tray.
- j. Insert keyboard tray into rack mounting rails. Slide tray until it locks.
- k. Set replacement mouse on mousepad. Pass cable for mouse through opening in pocket of keyboard tray. Leave 12 inches of cable between mouse and pocket opening.
- l. Secure both mouse cable and the keyboard cable to the cable tie mount on rear of left slide, using a short cable tie.
- m. Slide the tray into the rack until it reaches the end
- n. Ensure that the keyboard tray slides freely without excessive resistance. Adjust the slides if necessary.
- o. Secure both mouse and keyboard cables along the length of the cable retractor using six short cable ties. Do not stretch out keyboard cable coils.
- p. Connect keyboard cable to adapter cable; connect keyboard adapter and mouse cables to computer rear panel.
- q. Turn on computer and wait for it to sequence through initialization routines.
- r. The HECU program will automatically restart with HICs and CMIs at their last state.

NOTE

If the HECU watchdog timer is connected to a remote monitoring site, that site should be notified after completing this procedure.

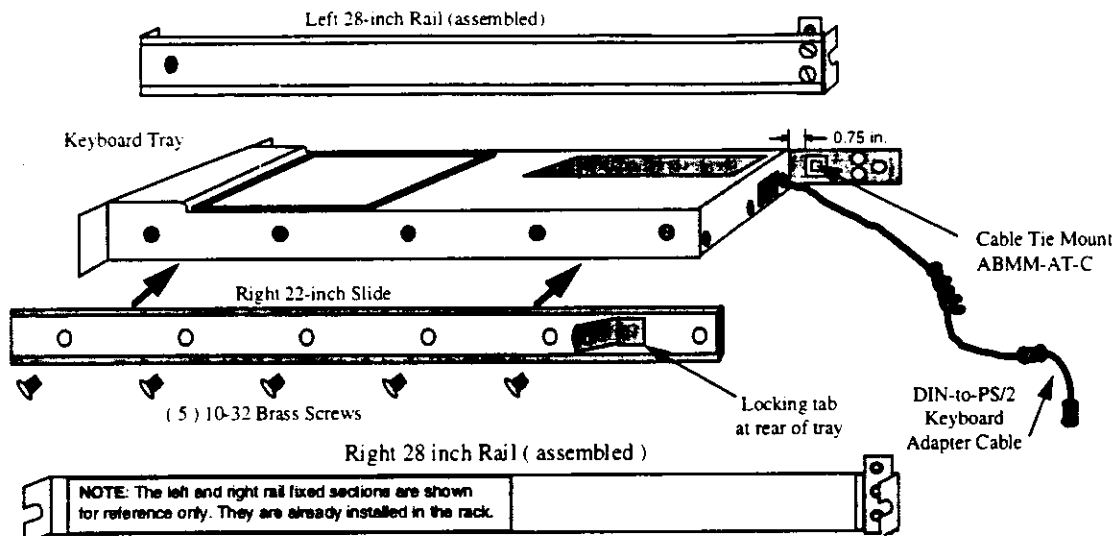

Figure 5-3. Keyboard Tray Replacement

5.3.2.4 Mouse Replacement Procedure

This procedure contains instructions for removing a defective HECU mouse and installing a replacement unit.

WARNING

The voltages and current levels present in the rack are potentially lethal. This procedure requires work inside the rack. Use extreme caution to avoid coming into contact with the +24V at the Prime Power Panel or on the 24 VDC bus bar.

NOTE

During Mouse replacement, the HIC/CMI system will continue normal operation, but any HIC or CMI alarms will not be detected and reported by the HECU. If the HECU watchdog timer is connected to a remote monitoring site, that site should be notified before performing this procedure.

Individual components of the HECU have a two-year warranty. Any attempt to repair and/or break the seal to gain access to the internal subassemblies of a HECU component will void the warranty for the component. During the warranty period, a suspected defective HECU component should be returned to the seller for replacement or repair.

- a. Without shutting down the HECU Software, set computer power switch to OFF.
- b. At rear of rack, remove all tie wraps securing mouse cable.
- c. At the computer rear panel, disconnect cable from mouse connector.

- d. With the keyboard tray extended, route mouse cable out through opening in the pocket of the keyboard tray.
- e. Set replacement mouse on mousepad. Pass cable for mouse through opening in pocket of keyboard tray. Leave 12 inches of cable between mouse and pocket opening.
- f. Secure both mouse cable and the keyboard cable to the cable tie mount on rear of left slide, using a short cable tie.
- g. Secure both mouse and keyboard cables along the length of the cable retractor using six short cable ties. Do not stretch out keyboard cable coils.
- h. Connect the mouse cable to computer rear panel connector.
- i. Turn on computer and wait for it to sequence through initialization routines.
- j. The HECU program will automatically restart with the HICs and CMIs at their last state.

NOTE

If the HECU watchdog timer is connected to a remote monitoring site, that site should be notified after completing this procedure.

5.3.3 Headend Interface Converter (HIC) Replacement Procedures

The following paragraph provides a procedure for replacing a defective HIC. Normally, the HIC is replaced as a complete assembly. However, procedures are also provided for field replacement of two internal HIC components—Fan and Power Supply—after the expiration of the 2-year warranty.

NOTE

The HIC has a two-year warranty. Any attempt to repair and/or break the seal to gain access to the internal components of a HIC assembly will void the HIC warranty. During the warranty period, a suspected defective HIC should be returned to the seller for replacement or repair.

5.3.3.1 HIC Replacement Procedure

This procedure contains instructions for replacing a defective HIC and installing a replacement unit. Refer to Figure 5-4 for the following procedure.

WARNING

The voltages and current levels present in the rack are potentially lethal. This procedure requires work inside the rack. Use extreme caution to avoid coming into contact with the +24V at the Prime Power Panel or on the 24 VDC bus bar. Whenever possible, disconnect the 115 Vac and +24V power inputs to the rack.

ESD CAUTION

The HIC contains a circuit card assembly that is sensitive to Electrostatic Discharge (ESD) damage. Whenever handling the HIC, use ESD precautionary procedures to minimize the risk of permanent ESD damage to circuit card components. Low relative humidity level increases the potential for damage to ESD-sensitive devices.

- a. Delete HIC to be replaced per paragraph 4.3.1.3.
- b. On HIC to be replaced, set front panel PWR switch to **0** (off).
- c. Disconnect all rear panel cables from HIC, and mark locations as needed.
- d. Remove four screws from front panel that secure HIC to rack.
- e. Remove the HIC power connection. Loosen and remove the wing nut and washers from the HIC ground stud, then remove ground connections.
- f. Pull HIC forward until free of rack.
- g. Install replacement HIC into rack by sliding on angle brackets.
- h. Secure HIC using screws and washers that were previously removed.
- i. Connect the green ground wire of Power Cable 8332632G1 to HIC by sliding ring terminal onto the HIC PE ground stud. Slide ring terminal of additional ground cable 8331052G1 onto HIC PE ground stud. Secure with washers and wing nut.
- j. Connect HIC power cable to HIC.
- k. Connect all other previously disconnected cables to replacement HIC rear panel.
- l. Set power switch of new HIC to **1** (on).
- m. Activate (acquire) new HIC per paragraph 4.3.1.1.

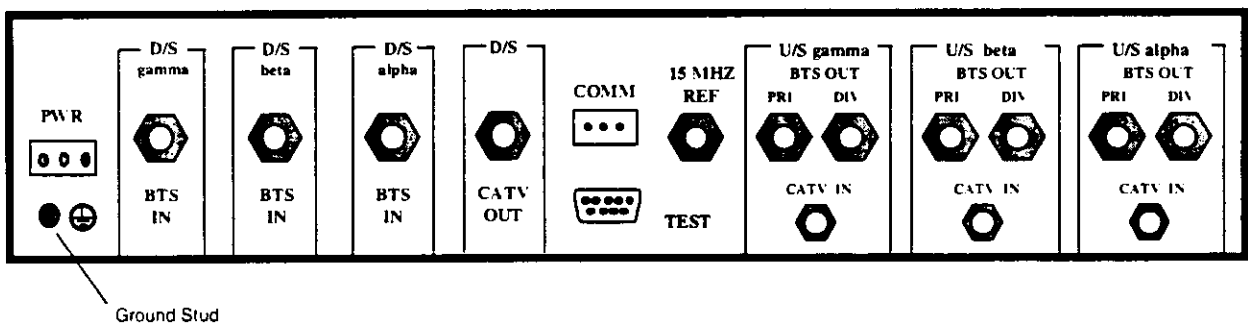

Figure 5-4. HIC Rear Panel

5.3.3.2 HIC Fan Replacement Procedure

This procedure contains instructions for replacing the HIC fan. Performing this procedure will void the 2-year HIC warranty and therefore should only be done after expiration of the warranty. The replacement procedure requires installing the connector to the fan using the parts provided with the replacement fan. The parts required are listed in Table 5-2.

WARNING

The voltages and current levels present in the rack are potentially lethal. This procedure requires work inside the rack. Use extreme caution to avoid coming into contact with the +24V at the Prime Power Panel or on the 24 VDC bus bar. Whenever possible, disconnect the 115 Vac and +24V power inputs to the rack.

 **ESD CAUTION**

The HIC contains a circuit card assembly that is sensitive to Electrostatic Discharge (ESD) damage. Whenever handling the HIC, use ESD precautionary procedures to minimize the risk of permanent ESD damage to circuit card components. Low relative humidity level increases the potential for damage to ESD-sensitive devices.

Table 5-2. Fan Replacement Parts

Item	Part No	Qty
Fan	031157	1
Contact	48234-000	3
Housing	65039-034	1

- a. Delete HIC to be repaired per paragraph 4.3.1.3.
- b. Set HIC front panel PWR switch to 0 (off) and remove HIC from rack per instructions in paragraph 5.3.3.1.
- c. While wearing a wrist strap connected to ground, place the HIC on a static-safe work bench.
- d. Loosen and remove six screws from top cover and six screws from bottom cover.
- e. Disconnect fan power cable from HIC.
- f. At HIC front panel, loosen and remove four screws, washers, and nuts that secure dust filter and fan to HIC unit.
- g. Cut wires to desired length (6–7 in.) on replacement fan.
- h. Strip about 3/8 inch of insulation from each wire.
- i. Crimp contact pins 48234-000 on to replacement fan wires.
- j. Insert replacement fan wires and spare contact pin in housing 65039-034. Ensure that replacement fan red wire is pin 1 and black wire is pin 2.
- k. Position and align replacement fan and dust filter to HIC front panel. Ensure that fan is oriented for proper air flow (intake in front) and that dust filter key is oriented for top and bottom (see Figure 5-1).
- l. Insert screws through front panel dust filter and fan. Secure with nuts and washers.

- m. Connect fan power cable to HIC connector.
- n. Install top cover and secure with six screws.
- o. Install bottom cover with notch cutout over downstream test point and secure with six screws.
- p. Reinstall HIC in rack per instructions in paragraph 5.3.3.1.
- q. Set power switch of repaired HIC to 1 (on).
- r. Activate (acquire) repaired HIC per paragraph 4.3.1.1.

5.3.3.3 HIC Power Supply Replacement Procedure

This procedure contains instructions for replacing a defective HIC Power Supply PS1 and installing a replacement unit. Performing this procedure will void the 2-year HIC warranty and therefore should only be done after expiration of the warranty.

WARNING

The voltages and current levels present in the rack are potentially lethal. This procedure requires work inside the rack. Use extreme caution to avoid coming into contact with the +24V at the Prime Power Panel or on the 24 VDC bus bar. Whenever possible, disconnect the 115 Vac and +24V power inputs to the rack.

ESD CAUTION

The HIC contains a circuit card assembly that is sensitive to Electrostatic Discharge (ESD) damage. Whenever handling the HIC, use ESD precautionary procedures to minimize the risk of permanent ESD damage to circuit card components. Low relative humidity level increases the potential for damage to ESD-sensitive devices.

NOTE

Individual components of the HIC have a two-year warranty. Any attempt to repair and/or break the seal to gain access to the internal subassemblies of a HIC component will void the warranty for the component. During the warranty period, a suspected defective HIC component should be returned to the seller for replacement or repair.

- a. Set the front panel PWR switch to 0 (off) and remove HIC from rack per instructions in paragraph 5.3.3.1.
- b. While wearing a wrist strap connected to ground, place the HIC on a static safe work bench.
- c. Loosen and remove six screws from top cover and six screws from bottom cover.

- d. At HIC power supply, loosen — but do not remove — six screws.
- e. At power supply heatsink, remove six nuts, six flat washers and six lock washers.
- f. Lift heatsink from power supply.
- g. Gently lift and disconnect power supply from circuit board connector. Ensure six screws, six flat washers, and six plastic washers remain attached to circuit board.
- h. Align and install replacement power supply over the six screws. (Plastic washers should remain between power supply and circuit board.)
- i. Push with firm even pressure to connect replacement power supply to circuit board.
- j. Install heatsink on power supply.
- k. Install flat washer, lock washer, and nut on each screw to secure power supply/heatsink to circuit board.
- l. Tighten all six screws and nuts.
- m. Install top cover and secure with six screws.
- n. Install bottom cover with notch cutout over downstream test point and secure with six screws.
- o. Reinstall HIC in rack per instructions in paragraph 5.3.3.1.
- p. Set power switch of repaired HIC to 1 (on).
- q. Activate (acquire) repaired HIC per paragraph 4.3.1.1.

5.3.4 15 MHz Distribution Assembly Replacement Procedure

This procedure contains instructions for removing a defective 15 MHz Distribution Assembly and installing a replacement assembly.

WARNING

The voltages and current levels present in the rack are potentially lethal. This procedure requires work inside the rack. Use extreme caution to avoid coming into contact with the +24V at the Prime Power Panel or on the 24 VDC bus bar.

NOTE

Removal of 15-MHz input from HICs will cause all Phase-Locked Loops (PLLs) to lose lock; the HICs will be inoperative during this procedure.

- a. Without shutting down the HECU Software, set the HECU Computer power switch to OFF.
- b. Turn off the +24V circuit breaker at the rack rear power panel.

- c. Disconnect the 15 MHz Distribution Assembly +24V power cable from the 24 VDC bus bar.
- d. Mark and disconnect RF input cable connected to J1 of the 15 MHz Distribution Assembly.
- e. Disconnect all remaining RF output cables (quantity varies between installations) connected to the 15 MHz Distribution Assembly.
- f. Loosen and remove the four bolts and washers that secure the 15 MHz Distribution Assembly to the rack.
- g. Package and return defective 15 MHz Distribution Assembly to the seller for disposition.
- h. Position and secure replacement 15 MHz Distribution Assembly directly behind the Monitor using four mounting bolts and washers.
- i. Connect marked RF input cable to J1 of the 15 MHz Distribution Assembly.
- j. Connect all previously disconnected RF output cables (quantity varies between installations) to the 15 MHz Distribution Assembly.
- k. Connect the 15 MHz Distribution Assembly +24V power cable to the 24 VDC bus bar.
- l. Set the +24V circuit breaker to ON at the rack rear power panel.
- m. Set the +115 Vac switch to ON at the rack ISOBAR Surge Suppressor.
- n. Set the HECU Computer power switch to ON.
- o. Repeat the following Steps for each of the acquired HICs in the rack.
 - Observe the PLL Status of the HIC, and ensure all PLLs are Locked. In normal operation, NO PLLs should be unlocked.
 - Select Comm Stats and observe that HIC COMMUNICATIONS STATISTICS Dialog appears.
 - Click Update Stats to update current data, ensure data updates.
 - Click OK to return to HIC CONTROL PANEL Dialog.

5.3.5 Optional +24V Power Supply Replacement Procedure

Racks that require an internal +24V supply have the optional +24V Power Supply, part 8303743G1, installed in HIC1 and HIC2 positions in the rack. This procedure contains instructions for removing a defective +24V Power Supply and installing a replacement power supply.

WARNING

The voltages and current levels present in the rack are potentially lethal. This procedure requires work inside the rack. Use extreme caution to avoid coming into contact with the +24V at the Prime Power Panel or on the 24 VDC bus bar. Whenever possible, disconnect the 115 Vac and +24V power inputs to the rack.

CAUTION

Removal of +24V input to HICs will cause all HICs to be inoperative during this procedure.

5.3.5.1 Optional +24V Power Supply Removal

- a. Turn off +24V Power Supply circuit breaker CB1 at power supply front panel and observe that DS1 indicator goes out.
- b. At rear of rack, set +24 VDC BUSBAR POWER circuit breaker to OFF.
- c. Set 115 Vac power switch to OFF (located at top of rack on the ISOBAR® Surge Suppressor).and disconnect 115 Vac ISOBAR® power cable from power source.
- d. At the power supply rear panel, remove the two screws and washers that secure the Plexiglas protector over the V1 terminals and set aside.
- e. Loosen and remove the two nuts and washers that secure the power supply output wires to the V1 terminals.
- f. At the power supply rear panel, remove the two screws and washers that secure the Plexiglas protector over the 115 Vac terminals (L1, L2, and ground) and set aside.
- g. Loosen and remove the three nuts and washers that secure the 115 Vac input wires to the L1 (black), L2 (white), and ground (green) power supply input terminals.
- h. Loosen and remove the four bolts and washers that secure the +24V Power Supply to the rack.
- i. Remove defective +24V Power Supply from rack.
- j. Package and return defective +24V Power Supply to the seller for disposition.

5.3.5.2 Optional +24V Power Supply Replacement

- a. Set front panel PWR switch to 0 (off) on all HICs in Rack.
- b. Position and secure replacement +24V Power Supply using four mounting bolts and washers.
- c. Install wires to the + and - V1 terminals and secure with the two nuts and washers.
- d. Install Plexiglas protector over the V1 terminals and secure with the two screws and washers previously set aside.
- e. Install 115 Vac input wires to the L1 (black), L2 (white), and ground (green) power supply input terminals and secure with the nuts and washers.
- f. Install Plexiglas protector over the 115 Vac input terminals and secure with the two screws and washers previously set aside.
- g. Connect the +24V Power Supply power cable (if applicable) to a white outlet.
- h. Secure replacement +24V Power Supply to the rack with the four bolts and washers.
- i. Set the +115 Vac switch to ON at the rack ISOBAR Surge Suppressor.

- j. Turn on the +24V Power Supply and observe that DS1 indicator comes on.
- k. Adjust the front panel V1 ADJ for +24.0 +/-0.5 V reading on the front panel VOLTAGE meter.
- l. Set the +24V Power Supply circuit breaker CB1 to ON at the Prime Power panel.
- m. Set the front panel PWR switch to 1 (on) on all the HICs in the Rack.

5.3.6 Installing and Interconnecting Headend Expansion Rack

For installing and/or interconnecting the Headend Expansion Rack, refer to the installation instructions contained in the Implementation Manual for Headend Equipment (Primary/Expansion) Rack and Cable Microcell Integrator, Document Number 8337147.

5.4 CMI ASSEMBLY DISASSEMBLY/ASSEMBLY INSTRUCTIONS

The CMI Assembly can either be replaced as a unit or repaired by replacing defective components. Figure 5-6 shows the location of the replaceable components in the CMI Assembly:

- Power Extractor
- Transceiver
- Power Amplifier
- Power Supply
- Duosil Gasket
- DC Harness

5.4.1 CMI Access

5.4.1.1 Opening the Assembly

WARNING

Potentially dangerous High Voltage exists on the AC power cable to the CMI Assembly that could cause bodily injury or even death. During a line surge or fault condition, High Voltage also could be present on the antenna connectors. Use extreme care and required safety precautions while working on the CMI.

The CMI hinged cover (road side) contains the Power Supply and therefore is **heavy**. If a CMI must be opened in the installed position, always support the cover with one hand when releasing the last captive screw to avoid equipment damage and/or personal injury.

ESD CAUTION

The CMI contains circuit card assemblies that are sensitive to Electrostatic Discharge (ESD) damage. Whenever handling the CMI, use ESD precautionary procedures to minimize the risk of permanent ESD damage to circuit card components. Low relative humidity level increases the potential for damage to ESD-sensitive devices.

- a. Approach the target CMI from the road side, and position maintenance bucket for best access to the eight captive bolts that secure the CMI cover.
- b. Using a 1/2-inch socket wrench, loosen the eight bolts securing the CMI cover in the order shown in the figure below.

5.4.1.2 Closing the Assembly

CAUTION

When closing the CMI Assembly, ensure that all internal wiring is clear of the housing seal before securing captive screws to avoid possible equipment damage.

NOTE

To restore the watertight seal on a CMI Assembly, the captive bolts must be torqued to 140–145 in-lb, in the proper sequence.

Place the CMI Assembly on any firm surface. Carefully close the cover, ensuring that all internal wiring is clear of the housing seal. Torque the eight captive bolts to 140–145 in-lb, in the sequence shown in Figure 5-5.

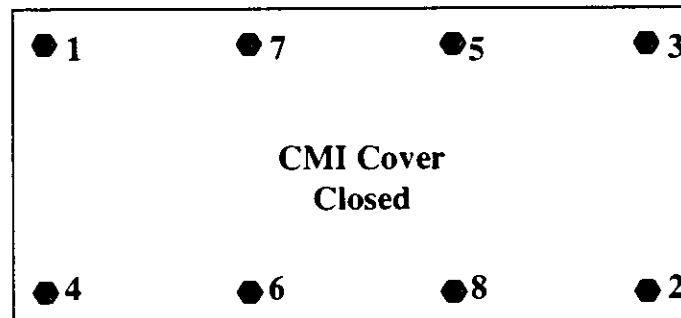

Figure 5-5. CMI Bolt Tightening Sequence

WARNING

If you are unsure whether the CMI transmitter is active, maintain a minimum distance of **8 inches** from the transmit antenna until the AC power has been disconnected from the CMI Power Supply.

NOTE

Individual active components of the CMI have a two (2)-year warranty. Any attempt to repair and/or break the seal to gain access to the internal subassemblies of a CMI component will void the warranty for the component. During the warranty period, a suspected defective CMI component should be returned to the seller for replacement or repair.

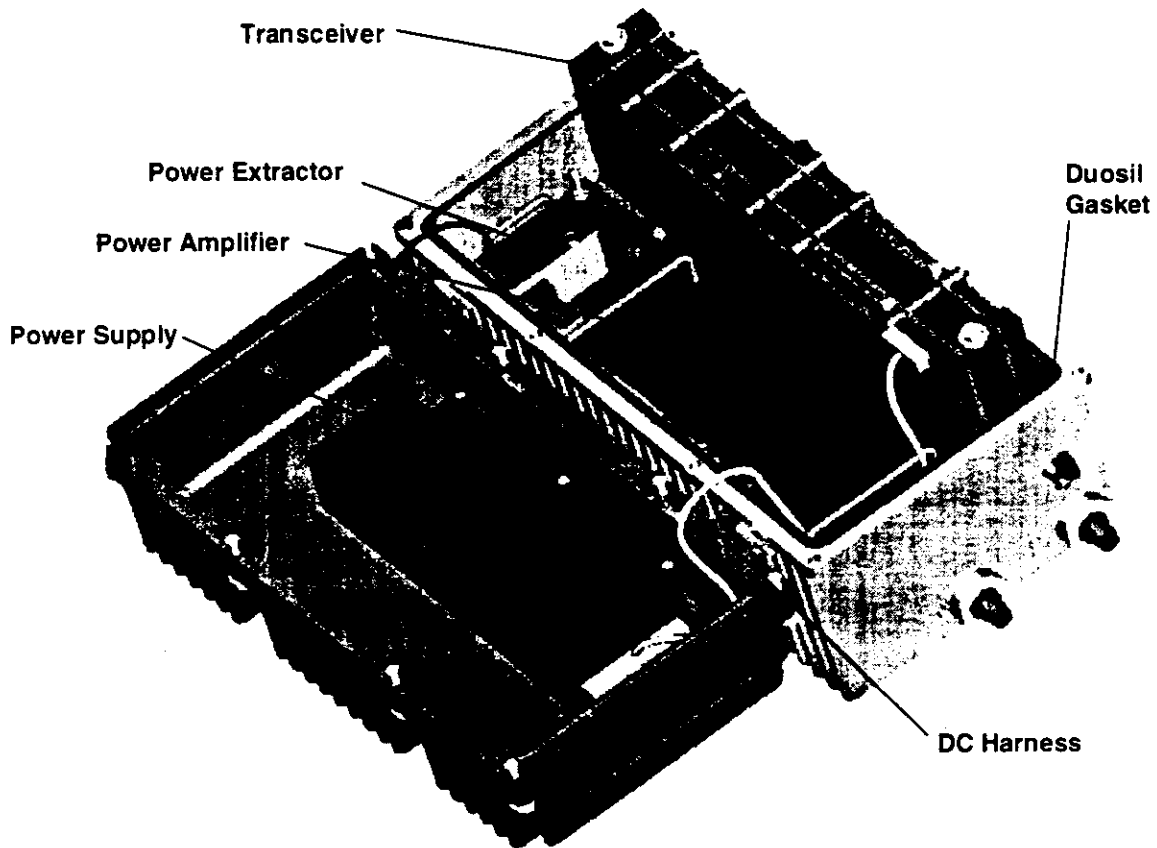

Figure 5-6. CMI Assembly Location Diagram

5.4.2 Power Extractor Replacement Procedure

Figure 5-6 shows the Power Extractor location in the CMI Assembly. Figure 5-7 shows the location of items used in the replacement of the Power Extractor in the CMI.

WARNING

Potentially dangerous High Voltage exists on the Power Extractor and Power Supply of the CMI Assembly that could cause bodily injury or even death. Use extreme care and required safety precautions while working on the CMI.

The CMI hinged cover (road side) contains the power supply and therefore is heavy. When opening the CMI for repair, always support the cover with one hand when releasing the last captive bolt to avoid equipment damage or possible bodily injury.

- a. To access components, loosen eight captive bolts that secure CMI hinged cover; support cover while loosening last bolt.
- b. Locate Power Extractor (Figure 5-6) in the CMI.

- c. Note position of AC power selector switch, either FWD/REV or ALT/FWD, and set the switch to the OFF position.
- d. Loosen captive screw that secures Power Extractor to CMI chassis.

CAUTION

When lifting the Power Extractor, use care to avoid straining the cable between the Power Extractor and the Power Supply.

- d. Carefully lift Power Extractor away from CMI chassis.
- e. Disconnect Power Extractor AC connector (Figure 5-7) from Power Supply connector.
- f. Disconnect Power Extractor +5VDC line from CMI wiring harness.
- g. Confirm that replacement Power Extractor is same configuration as the one being replaced: Serial number format is 979T*mm*2*cxxxx*, where *mm* is month of manufacture and *c* is either 1 if single port or 2 if dual port.
- h. Note UP ATTEN, DN ATTEN and EQUALIZER values installed in existing Power Extractor, and ensure that same values are installed in replacement Power Extractor.
- i. Remove pads and equalizer from the defective Power Extractor, and set Power Extractor aside for shipment to the repair facility.
- j. With power extractor AC selector switch set to OFF connect replacement Power Extractor AC cable to Power Supply AC connector jack.
- k. Connect replacement Power Extractor +5VDC line to CMI wiring harness.
- l. Carefully align and insert replacement Power Extractor in CMI chassis and tighten captive screw to secure.
- m. Set AC power selector switch to the original position noted in step c.
- n. Verify that the Power Supply green LED is lit.

CAUTION

Before securing captive screws on the CMI Assembly housing, ensure that all internal wiring is clear of the housing seal to avoid possible equipment damage.

NOTE

To maintain the watertight seal on the CMI Assembly, the captive screws must be torqued to 140–145 in-lb.

- m. Close CMI cover per paragraph 5.4.1.2.

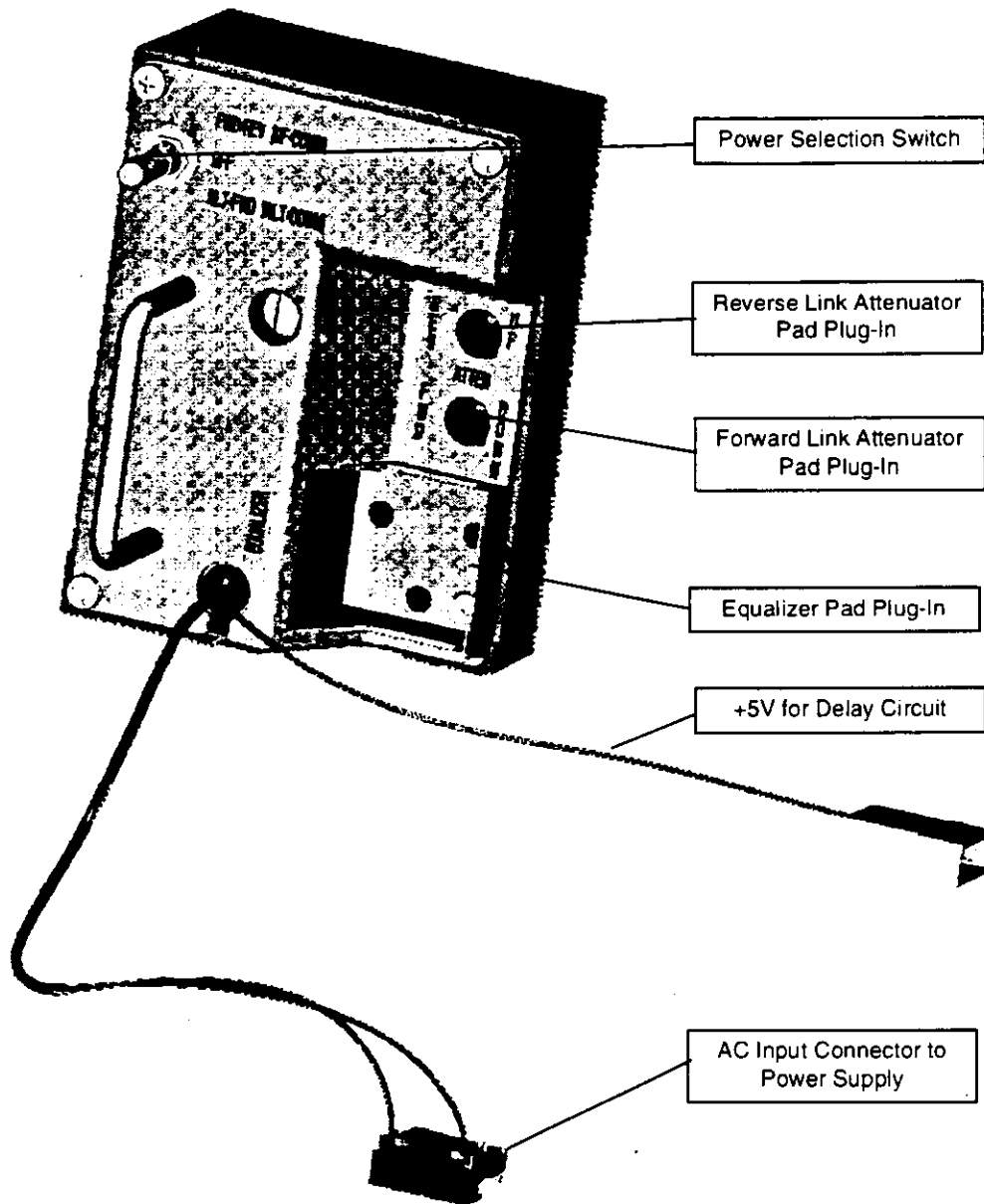

Figure 5-7. Power Extractor Location Diagram

5.4.3 Transceiver Replacement Procedure

Figure 5-6 shows the Transceiver location in the CMI Assembly. Figure 5-8 shows the location of items used in the replacement of the Transceiver in the CMI.

WARNING

Potentially dangerous High Voltage exists on the CMI Assembly that could cause bodily injury or even death. Use extreme care and required safety precautions while working on the CMI.

- a. Loosen eight captive bolts that secure CMI cover to access components.

- b. Note Power Extractor switch position, then set to OFF. Confirm that green LED on Power Supply is no longer lit.
- c. Locate Transceiver (Figure 5-6) in the CMI.
- d. Disconnect CMI wiring harness from Transceiver connector (Figure 5-8).
- e. Loosen two bolts that secure Transceiver to CMI chassis and lift Transceiver away from CMI chassis.
- f. Set aside defective Transceiver for shipment to repair facility.
- g. Align replacement Transceiver in CMI chassis and torque two bolts to 120 in-lb.
- h. Connect wiring harness to replacement Transceiver connector.
- i. Set Power Extractor switch back to original position.
- j. Verify that the Power Supply green LED and Transceiver PS LED are lit.

CAUTION

Before securing captive screws on the CMI Assembly housing, ensure that all internal wiring is clear of the housing seal to avoid possible equipment damage.

NOTE

To maintain the watertight seal on the CMI Assembly, the captive screws must be torqued to 140–145 in-lb.

- k. Close CMI per paragraph 5.4.1.2.

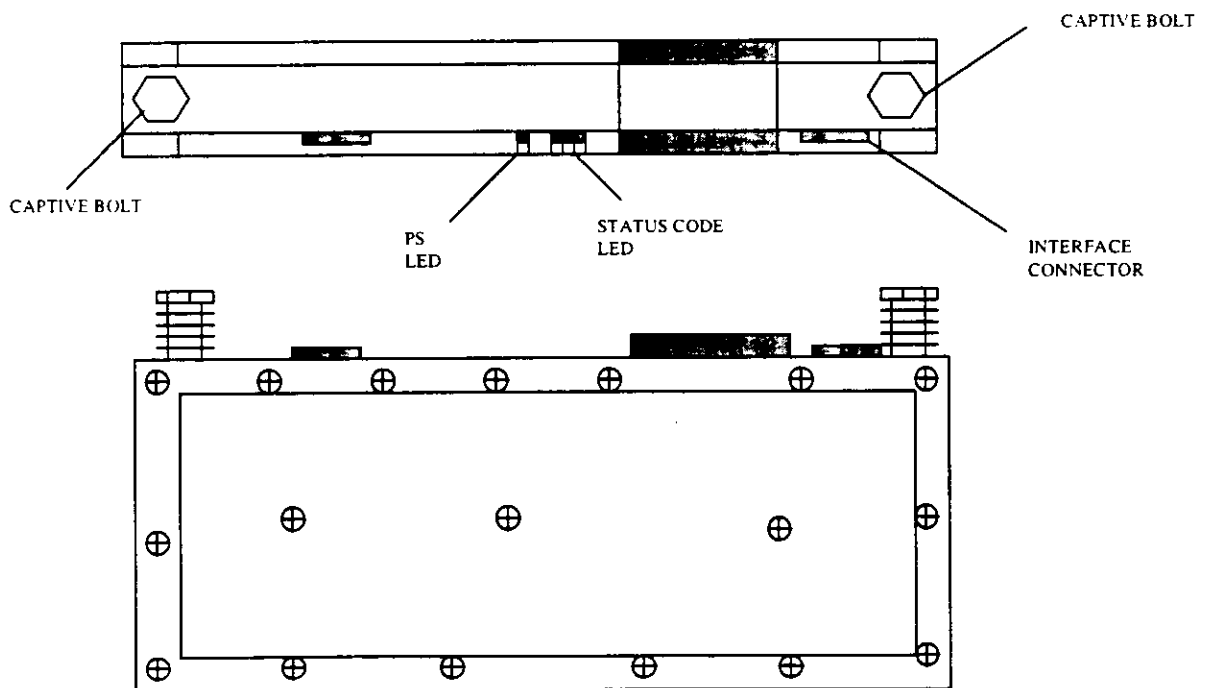

Figure 5-8. Transceiver Location Diagram

5.4.4 Power Amplifier Replacement Procedure

Figure 5-6 shows the Power Amplifier location in the CMI Assembly. Figure 5-9 shows the location of items used in the replacement of the Power Amplifier in the CMI.

WARNING

Potentially dangerous High Voltage exists on the AC power cable to the CMI Assembly that could cause bodily injury or even death. Use extreme care and required safety precautions while working on the CMI and handling the AC power cable.

- a. Loosen eight captive bolts that secure CMI cover to access components.
- b. Note Power Extractor switch position, then set to OFF. Confirm that green LED on Power Supply is no longer lit.
- c. Locate Power Amplifier (Figure 5-6) in the CMI.
- d. Loosen six bolts (Figure 5-9) that secure Power Amplifier to CMI chassis.
- e. Using handles, lift Power Amplifier Module away from CMI chassis.
- f. Set aside defective Power Amplifier for shipment to the repair facility.
- g. Align replacement Power Amplifier in CMI chassis and tighten six bolts.
- h. Set Power Extractor switch back to original position.
- i. Verify that the Power Supply green LED and Transceiver PS LED are lit.

CAUTION

When closing the CMI Assembly, ensure that all internal wiring is clear of the housing seal before securing captive screws to avoid possible equipment damage.

NOTE

To maintain the watertight seal on the CMI Assembly, the captive screws must be torqued to 140–145 in.-lb.

- j. Close CMI per paragraph 5.4.1.2.

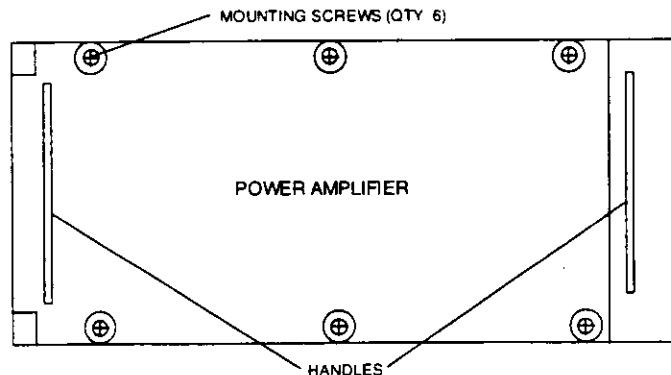

Figure 5-9. Power Amplifier Location Diagram

5.4.5 Power Supply Replacement Procedure

Figure 5-6 shows the Power Supply location in the CMI Assembly. Figure 5-10 shows the discrete parts required to replace the Power Supply in the CMI.

WARNING

Potentially dangerous High Voltage exists on the AC power cable to the CMI Assembly that could cause bodily injury or even death. Use extreme care and required safety precautions while working on the CMI and handling the AC power cable.

- a. Loosen eight captive bolts that secure CMI cover to access components.
- b. Note Power Extractor switch position, then set to OFF. Confirm that green LED on Power Supply is no longer lit.
- c. Disconnect Power Extractor AC connector (Figure 5-7) from Power Supply connector.
- d. Locate Power Supply (Figure 5-6) in the CMI.
- e. Loosen six bolts (Figure 5-10) that secure Power Supply to CMI cover.
- f. Gently lift Power Supply away from cover for access to connectors.
- g. Disconnect DC power cable from Power Supply DC connector.
- h. Set aside defective Power Supply for shipment to the repair facility.
- i. Connect DC power cable to replacement Power Supply DC connector.
- j. Align replacement Power Supply in CMI cover and tighten six bolts.
- k. Connect Power Extractor cable to replacement Power Supply.
- l. Set Power Extractor switch back to original position.
- m. Verify that the Power Supply green LED.

CAUTION

Before securing captive screws on the CMI Assembly housing, ensure that all internal wiring is clear of the housing seal to avoid possible equipment damage.

NOTE

To maintain the watertight seal on the CMI Assembly, the captive screws must be torqued to 145 in-lb.

- n. Close CMI per paragraph 5.4.1.2.

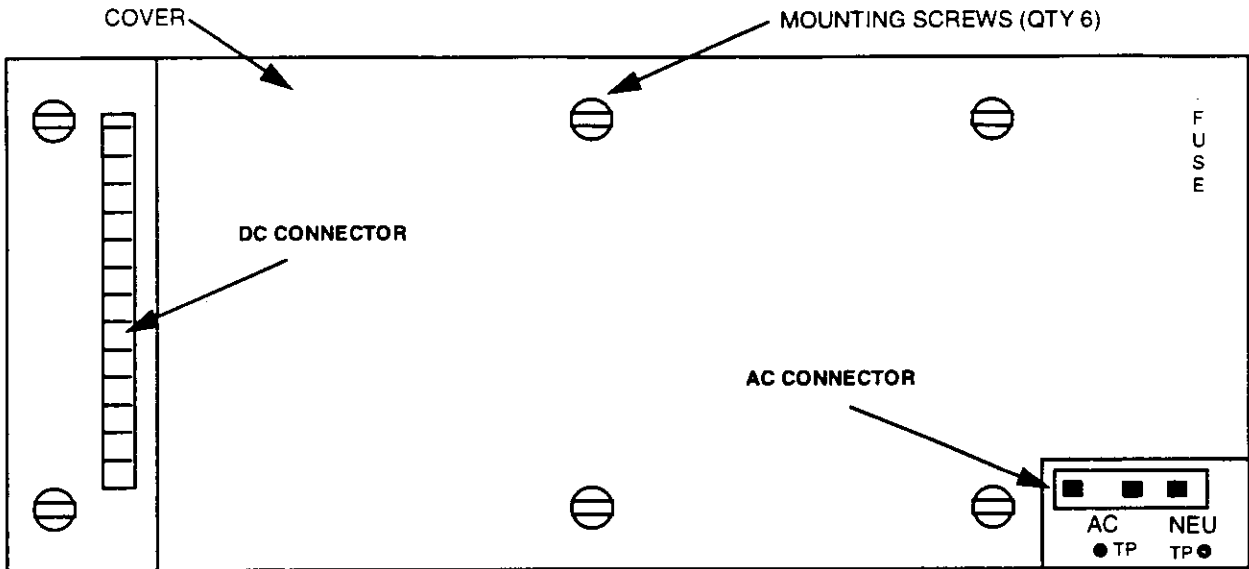

Figure 5-10. Power Supply Assembly Location Diagram

5.4.6 Duosil Gasket Replacement Procedure

As shown in Figure 5-11, the CMI uses a Duosil gasket, part number 8303696P1, for the combination weather seal and EMI gasket. In the event the Duosil gasket is damaged or worn, the affected CMI Assembly must be replaced so that its Duosil gasket can be replaced at the designated repair facility.

NOTE

The Duosil gasket cannot be replaced on site. The gasket is secured in the CMI Assembly with conductive adhesive (silver-filled silicon RTV) that requires a minimum of 2 hours of curing time for handling. A full cure is obtained in 24 hours.

- a. Loosen eight captive bolts that secure CMI cover and open cover of the CMI Assembly.
- b. Remove defective Duosil gasket from the CMI Assembly.
- c. Clean CMI gasket channel of any adhesive residue using trichloroethane or equivalent solvent.
- d. Wipe CMI gasket channel with acetone or methyl ethyl ketone (MEK) and let dry.
- e. Wipe replacement Duosil gasket with isopropanol alcohol moistened cloth.
- f. Apply bead of conductive adhesive in CMI gasket channel approximately every three inches.

NOTE

Steps *g* and *h* must be complete within 3-4 minutes after conductive adhesive has been applied.

- g. Orient and fit replacement Duosil gasket, part number 8303696P1, with elastomer seal facing outside and EMI mesh facing inside, in CMI gasket channel.
- h. Push Duosil gasket firmly into the CMI gasket channel.
- i. Let adhesive cure for 24 hours before closing CMI cover.

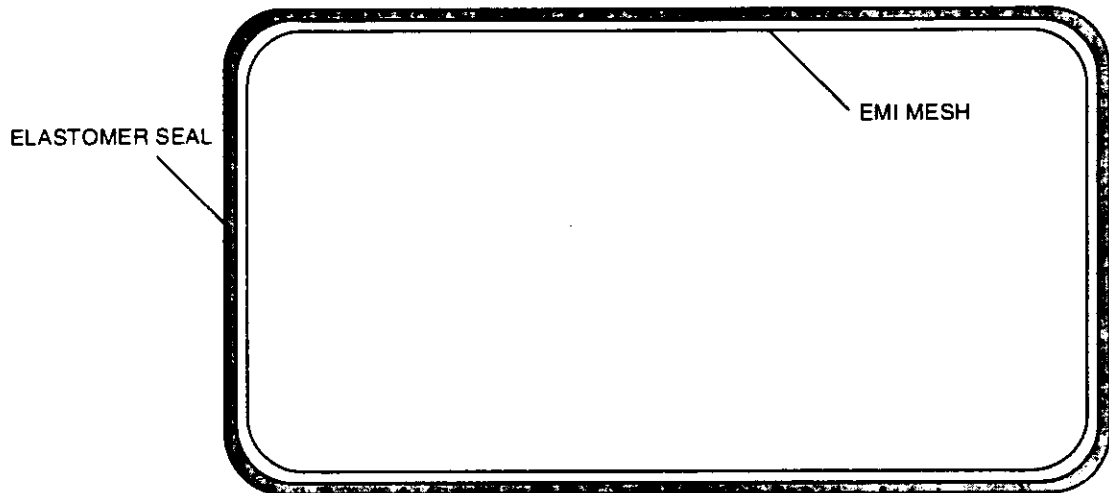

Figure 5-11. Duosil Gasket Replacement

5.4.7 DC Harness Replacement

The following procedure is provided for replacing a damaged or defective DC Harness. This procedure applies both to part number 8303777G1 and 8334693G1. Refer to Figure 5-12.

- a. Open CMI assembly cover per paragraph 5.4.1.1.
- b. Note Power Extractor switch position, then set to OFF position.
- c. Using a narrow tip, long shaft screw driver, loosen two screws holding 15-pin connector (1) to connector plate assembly in the base of CMI chassis, adjacent to Power Amplifier.
- d. Using wire cutters, clip two plastic tie wraps holding harness in place.
- e. Release connector (2) on 5VDC leg of harness from mating connector of power extractor cable and release from adhesive tie-down pad.
- f. Grasp release pin on the 16-pin white plastic Transceiver DC Receptacle (3) and remove input connector.
- g. Carefully rock 15-pin connector (1) with the screw driver and then slowly apply pressure and remove the leg of the harness until clear of the connector and free of the chassis.
- h. Carefully remove red 50-pin output connector (4) at right side of power supply by grasping at both ends and rocking it clear of pins.

- i. Verify that existing pressure-sensitive tie-down clips (5, 6) are secure. If not, remove them and clean surface area with the alcohol pad. When dry, affix new pads as needed (ABM2S-AT-C0, or equivalent).
- j. Position tie wraps (PLT1M-C, or equivalent) as follows: In cover (roadside), orient from top to bottom (5); in chassis, orient from right to left (6), as 15-pin leg of the harness runs vertical to the connector plate.
- k. Manually form new DC harness assembly to outline shape shown (7). Pre-shaping is required to correctly route harness from CMI cover to CMI chassis.
- l. Connect red 50-pin connector (4) to output pins of CMI Power Supply assembly located in CMI cover, routing cable to chassis. Loosely secure with tie wrap to hold in place.
- m. Maintaining the harness form, connect 15-pin connector (1) to connector plate assembly. Use a long shaft screw driver to seat connector flush to plate surface and then secure two hold-down screws. Loosely secure harness leg with tie wrap.
- n. Install white 16-pin connector (3) into Transceiver receptacle with release pin at top.
- o. Route new 5VDC lead through tie-down. Use tie wraps to hold the leads in place; *do not tighten* tie wraps at this time. Ensure that there is enough slack in harness for future removal and replacement of Power Amplifier.
- p. Connect 5VDC leg of harness (2) to mating connector of power extractor cable.
- q. Apply power to CMI Power Supply by selecting appropriate position on Power Extractor switch, either FWD/REV or ALT/FWD. Verify that Transceiver LEDs are lit.
 - 1) If Transceiver LEDs do not light, set Power Extractor switch back to OFF position, and check DC power connections to Power Supply and Transceiver.
 - 2) Set Power Extractor switch to appropriate "on" position. If Transceiver LEDs are still not lit, set Power Extractor switch to OFF, check Power Supply fuse and replace if needed.
 - 3) Again set Power Extractor switch to appropriate "on" position. If Transceiver LEDs are still not lit, measure the DC outputs at Power Supply test points per paragraph 5.5.3.3.2. If any DC voltage is missing or out of tolerance, replace power supply.
- r. Upon successful installation of new DC harness, use needle nose pliers to secure DC wire harness cable ties. When tight, use wire cutters to trim ties flush to pads.
- s. After cable ties are secure, re-verify that Power Extractor switch is in correct operating position.
- t. Close CMI assembly per 5.4.1.2.

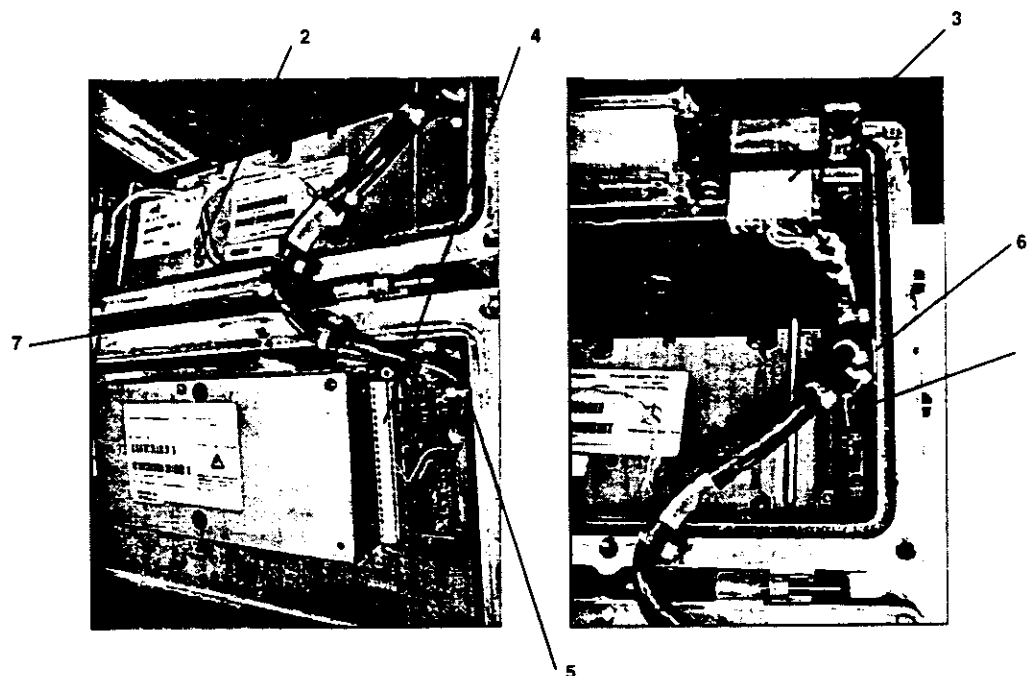

Figure 5-12. CMI Harness Replacement Location Diagram

5.4.8 Replacement of Entire CMI Assembly

For installing any replacement CMI Assembly, refer to the installation instructions contained in the Implementation Manual for Headend Equipment (Primary/Expansion) Rack and Cable Microcell Integrator, Document Number 8337147.

WARNING

If you are unsure whether the CMI transmitter is active, maintain a minimum distance of **8 inches** from the transmit antenna until the AC power has been disconnected from the CMI Power Supply.

5.5 TROUBLESHOOTING

Troubleshooting the PCS-Over-Cable System V1.85 hardware consists of:

- Using the HIC and CMI alarm messages, displayed at the HECU monitor, as an aid to fault isolating to the defective unit.
- Performing step-by-step procedures to fault isolate defective components that are not covered by the alarm messages.

5.5.1 Upstream and Downstream System Power Levels

Troubleshooting often requires measurement of RF signal levels using a spectrum analyzer, so Figure 5-13 is provided for power level reference. The figure shows RF signal levels at the input and output of the major assemblies for both Upstream and Downstream signal flow. RF signal levels are expressed both in terms of power (dBm) and voltage (dBmV). Values enclosed in boxes are specified requirements while those outside of the boxes are calculated or interpolated from specified requirements.

5.5.2 **Alarms**

In general, the HECU is not directly responsible for reconfiguring devices with alarms to put them into a "safe" state. Instead, this processing is handled by the HICs and CMIs themselves to the extent defined by the user through HECU-based software controls. The user is able to select for which types of HIC alarms and for which types of CMI alarms automatic error handling and reporting is performed by the respective devices.

5.5.2.1 **Alarm Displays**

The HECU displays show graphical representations of the HIC/CMI network being controlled. The HECU-level HEADEND CONTROL PANEL dialog displays the racks with color-coded icons representing the status of each HIC in position. Similarly, the HIC CONTROL PANEL dialog displays the status of the CMIs in each sector for a given HIC with color-coded icons. The icons periodically blink if the device they represent is currently in an alarmed state and the alarm has not been acknowledged. The color code used to indicate HIC and CMI status is:

- Gray No Device Present
- Green: Device active with no alarms
- Red: Critical Alarm, a failure that affects loss of many subscribers; e.g., no response from a HIC
- Orange: Major Alarm, a failure that causes loss of service to a small number of subscribers; e.g., no response from a CMI
- Magenta: Out of Service Alarm, a failure that may affect subscribers; e.g., an autogain validation check failure will cause an out-of-service alarm.
- Blue: Minor Alarm, a failure that does not immediately, directly affect subscribers; e.g., a CMI upstream temperature warning
- Yellow: Caution (Managed Device Has Alarm). For example, if a CMI has an alarm, the icon for the HIC that manages that CMI will display in yellow on the HEADEND CONTROL PANEL dialog.

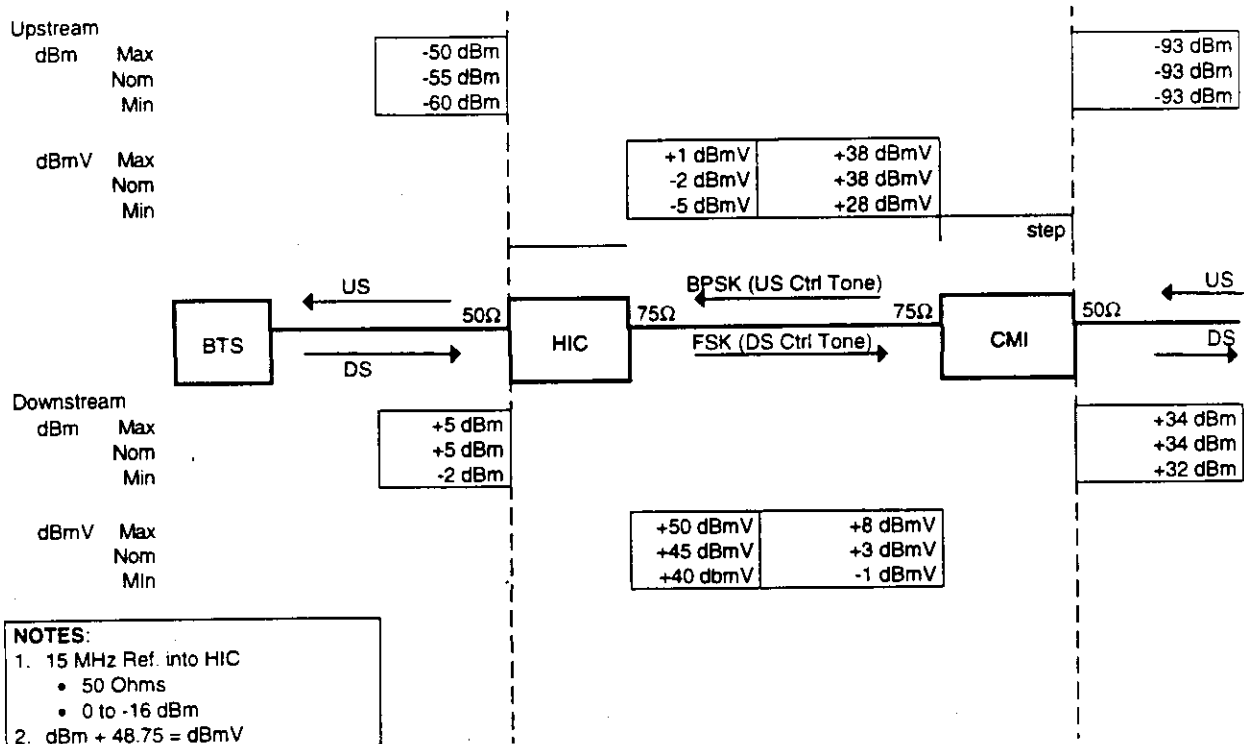

Figure 5-13. PCS-Over-Cable RF Power Levels at 65% Pole

5.5.2.2 Software Fault Detection

HICs and CMIs perform continuous self-test during operation to detect faults and determine whether each detected fault should be reported as an alarm. Each HIC continuously polls its CMIs for alarm status, and the HECU polls its HICs at user-defined intervals for both HIC and CMI alarm status. Alarms can be generated in several different ways:

- **Failure of a HIC to respond to a HECU status poll message** - The HECU keeps a record of all status poll messages sent to the HICs and check-marks them upon successful completion of the message. If no response is received to the status poll message, the HECU resends the message a user-selectable number of times. If no response is received after all retry messages have been sent, a potential alarm will be generated and sent to the HECU alarm processing module for disposition.
- **Fault indications in a returned status poll message** - Upon receipt of a successful poll message, the HECU checks to see if the HIC has indicated any alarms. If alarms are indicated, the HIC will determine which devices are tagged as having problems (alarm status bits set), and then the HECU will send a message to the HIC in question to get further information on the problem that caused the alarm. One of these messages will be generated for each device that is reported to have an alarm. The alarms that the HIC reports via these messages are prioritized based on urgency. Only the highest priority existing alarm will be reported by the HIC. A potential alarm will then be generated based on this information and sent to the HECU alarm processing function for disposition.
- **Error message returned by a CMI in response to a command** - If the HECU sends a message to a CMI (or all CMIs) to change parameters and the command fails, an alarm

message will be generated by the HIC that controls the faulty CMI(s). This message will contain information as to which CMI(s) failed and some indication of what caused the failure. This information will be used to construct a potential alarm to be passed on to the alarm processing function.

- Performance parameters out of range - The HECU can discover a potential alarm by monitoring performance data being collected from a given device, if data collection for that device is enabled (autostatistics). Upon receipt of the data, the HECU can compare the reported value of a parameter to a user-set operating range. If the parameter falls outside this range, the HECU generates a potential alarm and passes it to the alarm processing function for disposition.

The HIC and CMI will remain in alarmed states even after reporting the alarm to the HECU, either until the HECU acknowledges that alarm or it gets a higher priority alarm. The exception to this is for watchdog time-out or reset alarms, in which cases the CMI or HIC clears its alarm state after reporting to the HECU.

5.5.2.3 Alarm Message Prioritization and Status Polling

Alarms are first processed at the level where they occur, then reported on up the chain. The CMI continuously performs self-test and generates an alarm when it detects a fault. The alarms in the CMI are prioritized, so if there is more than one alarm pending, only the highest priority alarm will be reported. The HIC continuously polls its CMIs for alarm status. Each CMI sends a message reporting the status of its alarm bits to the HIC in response to the CMI alarm status request.

In addition to collecting the CMI alarm status, the HIC also performs continuous self-test and generates an alarm when it detects a fault of higher priority than any existing alarm. As with the CMI, the HIC alarms are prioritized, so if there is more than one alarm pending, only the highest priority alarm will be reported. The HIC and the CMI alarm status is then reported to the HECU in response to the status request in a message containing the status of the alarm bits in the HIC and all its associated CMIs. The HECU polls each HIC to collect alarm status at user-defined intervals.

If there is an alarm set in the HIC, the HECU requests the detailed alarm information from the HIC via the HIC Report Alarm message. Likewise, the detailed alarm information from the CMI is requested using the CMI Report Alarm message.

5.5.2.4 Alarm Information and Management

5.5.2.4.1 Alarm Information Displays

There are two types of active alarm information displays available from the **Alarms** menu on the HEADEND CONTROL PANEL dialog:

- **Show Unacknowledged Alarms** - lists all unacknowledged alarms
- **Show Open Alarms** - lists alarms for all devices that are in an alarmed state

From the list of alarms in these alarm displays, the user can select individual alarms and view more information on them. The alarms displayed in the lists contain information as to which device the alarm is associated with and are color-coded to indicate the alarm severity as described in paragraph 5.5.2.1.

5.5.2.4.2 Alarm Management

Alarm management addresses how and when the alarms are logged, displayed, acknowledged and cleared. Upon initial determination that a new alarm is present, the system adds that alarm to the active alarm list, to the unacknowledged alarm list, and to the alarm history log. At this time the icon depicting that device is set to blink periodically. In addition to the blinking icon, an audible alarm sounds periodically. The user has the option to disable the audible alarm.

In order to acknowledge an alarm, the operator selects **Alarms/Show Unacknowledged Alarms** from the HEADEND CONTROL PANEL dialog menu bar; the UNACKNOWLEDGED ALARMS dialog is displayed. After selecting (highlighting) one or more alarms, the operator clicks on Acknowledge. Upon acknowledgment, the alarm(s) remain active but the icons stop flashing and the audible alarm ceases. The alarm(s) also are removed from the unacknowledged alarm list, and the disposition field for the alarm in the alarm history log will be changed to "acknowledged."

In order to clear an alarm, the operator selects **Alarms/Show Open Alarms** from the HEADEND CONTROL PANEL dialog menu bar; the OPEN ALARMS dialog is displayed. After selecting one or more alarms, the operator clicks on Close. The system responds with a query message to be sure that clearing (closing) the alarm(s) is the desired action. Note that the authorized User or Super-User can clear an alarm even though the condition causing the alarm may still exist. In this case a new alarm would be generated the next time the alarmed device is polled. Upon being cleared, the disposition field for the alarm is changed to "cleared" in the alarm history log and a date/time stamp for the clearing event is added.

If the user deletes an alarmed device from the system, the alarm entries in the unacknowledged and open alarm lists corresponding to the device are removed. Refer to Section 4 for alarm display and review procedures.

5.5.2.5 HIC Alarm Messages

Table 5-3 provides a list of primary alarm messages associated with the HIC. The alarm messages indicate a fault exists in the HIC operation. In most cases, the reporting HIC is the most probable faulty component. In several cases, subalarms are provided with the primary alarm to indicate the functional area within the HIC that is defective.

Table 5-3. HIC Alarm Messages

Alarm: <i>PLL(s) Out of Lock</i>	Fault: HIC	Recovery: See Table 5-5, 5.5.3.1.3
Description		
<p>The HIC acts differently depending upon which loop goes out of lock: <i>PLL #1 to PLL #6, Upstream Channel Select Loops</i> - The HIC tries to retune the PLL that is out of lock, and reports the alarm to the HECU. <i>PLL #7, Upstream PCS Frequency</i> - The HIC tries to retune, and reports the alarm to the HECU. <i>PLL #8, BPSK Demodulator</i> - The HIC reports the alarm to the HECU. <i>PLL #9, Downstream PCS Frequency</i> - The HIC tries to retune, and reports the alarm to the HECU. Then it waits the PLL settle time to see if the PLL locks up. If the PLL still is out of lock, the HIC turns off the reference tone and downstream CDMA signals. This causes all the CMLs to lose lock and shut off their power amplifier (PA) output and primary/diversity receive paths. <i>PLL #10 TO PLL #13, Downstream 2nd IF</i> - Same HIC action as for PLL #9. <i>PLL #14, FSK Tone</i> - Same HIC action as for PLL #9. <i>PLL #15, Reference Tone</i> - Same HIC action as for PLL #9.</p>		
Possible Causes		
<p>BTS: No 15 MHz output Low 15 MHz Reference Power level PCS HE: (all PLLs) Bad cable, connector, or Distribution Amplifier HIC: (1 or 2 PLLs unlocked)</p>		
Alarm: <i>HIC Temperature Alarm</i>	Fault: HIC	Recovery: Check cooling fan & air filter
Description		
<p>If the CCA temperature exceeds a preset threshold (70°C), the HIC will report the alarm to the HECU and turn off the reference tone and downstream CDMA signals. This causes all the CMLs to lose lock and shut off their PA output and primary/ diversity receive paths. Related Alarm: HIC Temperature Warning</p>		
Possible Causes		
<ul style="list-style-type: none"> • Temp. in HIC exceeds 70° C • Cooling fan not working • Air filter needs cleaning 		
Alarm: <i>Watchdog Time-Out</i>	Fault: HIC	Recovery: N/A - Advisory alarm
Description		
<p>If the HIC did not write to the watchdog timer for a set length of time, The HIC reinitializes, using the same code as for an initial power-up. Related Alarms: HIC Reset, HIC Didn't Answer Status Poll</p>		
Possible Causes		
<p>HIC was in an unknown state and re-initialized</p>		

Table 5-3. HIC Alarm Messages (Continued)

Alarm: <i>Device Reset</i>	Fault: HIC	Recovery: N/A - Advisory alarm
Description		
The HIC will reinitialize, using the same code as for an initial power-up. Related Alarm: Watchdog Time-Out		
Possible Causes		
<ul style="list-style-type: none"> • Operator performed a soft reset. • Power was cycled on the HIC Power outage and power restored		
Alarm: <i>HIC Temperature Warning</i>	Fault: HIC	Recovery: Check cooling fan & air filter
Description		
If the HIC CCA temperature exceeds 60°C, the HIC reports the alarm to the HECU. Related Alarm: Temperature Alarm		
Possible Causes		
<ul style="list-style-type: none"> • Temp. in HIC exceeds 60° C • Cooling fan not working • Air filter needs cleaning 		
Alarm: <i>Alpha/Beta/Gamma DS CDMA Input Power Out of Range</i>	Fault: HIC	Recovery: Determine HIC CDMA input via GUI; measure HIC CDMA output.(See Table 5-10, Table 5-11)
Description		
The HIC's measured CDMA input power from the BTS is low. The HIC reports the alarm to the HECU.		
Possible Causes		
Input CDMA power to HIC is low. <ul style="list-style-type: none"> • BTS was re-initialized, or cell sector not functional (no CDMA output) • HIC/BTS interface not connected, or high loss in cable/connector Related Symptom: GUI shows dashed lines for HIC CDMA input power on the sector that is alarming.		
Alarm: <i>HIC Didn't Answer Status Poll</i>	Fault: HIC	Recovery: Cycle power. Restore RS-485 connection
Description		
HECU sends the alarm after failure of the user-defined number of retries. Related Alarm: Reset HIC		
Possible Causes		
<ul style="list-style-type: none"> • HIC was in an unknown state and re-initialized • Power turned OFF on HIC • RS-485 not connected (or bad connection) 		

Table 5-3. HIC Alarm Messages (Continued)

Alarm: <i>DS Power Range Error</i>	Fault: HIC	Recovery: Check HIC input levels; check HIC attenuator settings (see Table 5-5)
Description		
The combined broadband output power of the HIC is too low.		
Possible Causes		
<ul style="list-style-type: none"> • Reference and/or Control tone is disabled. • CDMA Output disabled. • DS Attenuators too high (CDMA, Reference, Control) 		
Alarm: <i>Flash Write Failure</i>	Fault: HIC	Recovery:
Description		
Failed to write to Flash memory.		
Possible Causes		
Alarm: <i>Flash Checksum Failure</i>	Fault: HIC	Recovery:
Description		
Possible Causes		

5.5.2.6 CMI Alarm Messages

Table 5-4 provides a list of primary alarm messages associated with the CMI. The alarm messages indicate a fault exists in the CMI functional operation. Unlike the HIC, internal CMI components are replaced to repair the defective CMI. Table 5-4 lists the most probable faulty component within the CMI. Similarly, CMI subalarms are provided with the primary alarm to indicate the functional area within the CMI component that is defective.

Table 5-4. CMI Alarm Messages

Alarm: <i>CMI Not Responding</i>	Fault: CMI; Cable plant; HE	Recovery: CMI soft reset; Power On Reset (See Figure 5-21)
Description		
<p>This alarm is generated at the HIC level when a CMI does not respond to a pre-defined number of consecutive autostatistics or autogain messages.</p> <p>The HIC generates an alarm for that CMI and when the HECU polls the HIC for alarm information, the HIC sends the alarm to the HECU. The HIC still attempts to send autostatistics and autogain messages to the CMI, but it sets a field telling the CMI that the CMI is not responding.</p> <p>The CMI keeps count of how many consecutive messages with this field set it receives. If that count exceeds the defined number, the CMI forces a self reset with its PA and receive channels off. The CMI then generates a NO_RESPONSE_ERROR condition that is reported to the HIC.</p> <p>If the HIC receives the NO_RESPONSE_ERROR condition from the CMI, the HIC tries to reactivate the CMI to the last active state.</p>		
Possible Causes		
<p>CMI - XCVR in an unknown state</p> <p>Cable Plant - DS or U/S link problem (node, line amp, equalizer, etc.)</p> <p style="padding-left: 20px;">- Excessive CATV plant noise</p> <p>Cable HE - combiner/splitter problem between HIC and headend</p> <p style="padding-left: 20px;">- U/S/DS laser not functional</p>		
Alarm: <i>EEPROM Checksum Failure</i>	Fault: XCVR	Recovery: Re-download code to CMI
Description		
<p>If the calculated checksum does not match the stored checksum, the CMI generates an alarm and reports to the HIC when the CMI is polled. The CMI then turns off its PA output and primary/ diversity receive paths. The HIC reports the alarm to the HECU.</p>		
Possible Causes		
CMI - XCVR software corrupted		
Alarm: <i>Waiting In EEPROM</i>	Fault: XCVR	Recovery: CMI soft reset
Description		
<p>This alarm is generated by the CMI when the code download flag is set, but no code is received.</p>		
Possible Causes		
<ul style="list-style-type: none"> • CMI is waiting for EEPROM code to be downloaded • CMI download button was selected 		
Alarm: <i>EEPROM Write Failure</i>	Fault: XCVR	Recovery: Try to write to EEPROM again
Description		
<p>During CMI download, if a byte is not written correctly to the EEPROM, the CMI generates this alarm, and reports it to the HIC.</p>		
Possible Causes		
<ul style="list-style-type: none"> • Number of writes to EEPROM exceeded (10,000 maximum) • EEPROM problem 		

Table 5-4. CMI Alarm Messages (Continued)

Alarm: <i>PLLs Out of Lock</i>	Fault: XCVR	Recovery: See Table 5-15
Description		
If one or more PLLs are unlocked, the CMI generates an alarm and reports it to the HIC. The CMI then tries to retune the appropriate PLL. If it does not lock, the CMI turns off its PA output and primary/diversity receive channels. The HIC reports the alarm to the HECU.		
Possible Causes		
<ul style="list-style-type: none"> • Low reference/control tone at CMI input (out of range) • DS link in cable plant broken • HIC lost reference from BTS (CMIs are referenced from HIC) 		
Alarm: <i>No Response Error</i>	Fault: Cable Plant; XCVR; PE	Recovery: N/A - Advisory Alarm
Description		
The CMI will generate this alarm if it receives a set number of CMI NOT RESPONDING messages from the HIC.		
Related Alarms: CMI Not Responding, CMI Reset (communications restored)		
Possible Causes		
CMI sends message due to high No. of time-outs, caused by poor communication link, usually (but not necessarily) prior to resetting itself		
Alarm: <i>Downstream Power Out Exceeds Limit</i>	Fault: CATV plant; PA; XCVR	Recovery: See Table 5-14
Description		
If the CMI XCVR downstream output power exceeds a preset threshold (-20 dBm), the CMI turns off the PA and the primary and diversity receive channels. It then registers this alarm, CMI reports it to the HIC.		
Possible Causes		
<ul style="list-style-type: none"> • DS attenuator set too low • Low PA Gain • Intermittent Transceiver DS Gain with DS AGC 		
Alarm: <i>Communications Time-out</i>	Fault: XCVR; PE; PS; Cable Plant	Recovery:
Description		
If the Transceiver has autostats or autogain on and has not received a message from the HIC in about 15 minutes, the CMI turns off the power amplifier and the primary and diversity receive channels. It then registers this alarm, and the next time the HIC requests status, the CMI reports this alarm. The HIC sets the appropriate alarm bit, and reactivates the CMI to the state saved in EEPROM.		
Possible Causes		
Intermittent communications between CMI/HIC		

Table 5-4. CMI Alarm Messages (Continued)

Alarm: <i>Power Amp Temperature Alarm</i>	Fault: Power Amp	Recovery:
Description		
If the CMI PA temperature exceeds a preset threshold (85°C), the CMI turns off the PA and the primary and diversity receive channels. It then registers this alarm, and the next time the HIC requests status, the CMI reports this alarm.		
Possible Causes		
Power Amplifier is too hot.		
Alarm: <i>Upstream Temperature Alarm</i>	Fault: XCVR	Recovery: Check Upstream CCA Temp at CMI CONTROL PANEL
Description		
If the CMI upstream temperature exceeds a preset threshold (85°C), the CMI turns off the PA and the primary and diversity receive channels. It then registers this alarm, and the next time the HIC requests status, the CMI reports this alarm.		
Possible Causes		
U/S CCA in the transceiver too hot.		
Alarm: <i>Downstream Temperature Alarm</i>	Fault: XCVR	Recovery: Check Downstream CCA Temp at CMI CONTROL PANEL
Description		
If the CMI downstream temperature exceeds a preset threshold (85°C), the CMI turns off the PA and the primary and diversity receive channels. It then registers this alarm, and the next time the HIC requests status, the CMI reports this alarm.		
Possible Causes		
D/S CCA in the transceiver too hot.		
Alarm: <i>Upstream Power Out Exceeds Limit</i>	Fault: XCVR	Recovery: See Table 5-18
Description		
If the CMI upstream power exceeds a user-defined threshold the CMI adds attenuation to both the upstream primary and diversity paths, and maintains the added attenuation as long as the condition exists. The CMI registers this alarm, and the next time the HIC requests status, the CMI reports this alarm.		
Possible Causes		
CMI U/S power out has exceeded user-defined threshold		
Alarm: <i>Watchdog Time-Out</i>	Fault: XCVR	Recovery: N/A- -Advisory Alarm
Description		
If the CMI does not update its internal watchdog register, the CMI resets all its parameters to the previous state. The attenuator values will be the default, either from the ROM or the EEPROM. The CMI registers and reports this alarm to the HIC. The HIC sets the appropriate alarm bit.		
Possible Causes		
XCVR in an unknown state		

Table 5-4. CMI Alarm Messages (Continued)

Alarm: <i>CMI Reset</i>	Fault: XCVR	Recovery: N/A - Advisory Alarm
Description		
<ul style="list-style-type: none"> • If the CMI resets for any reason, it will report this alarm to the HIC. The CMI resets all its parameters to the previous state. The attenuator values will be the default, either from the ROM or the EEPROM. The CMI registers and reports this alarm to the HIC. The HIC sets the appropriate alarm. 		
Related Alarms: CMI Not Responding, No Response Error, Watchdog Time-out		
Possible Causes		
<ul style="list-style-type: none"> • Manual reset via GUI • Communications time-out • Power cycled on CMI or temporary power outage and power was restored to CMI 		
Alarm: <i>Power Amp Temperature Warning</i>	Fault: Power Amp	Recovery: N/A - Advisory Alarm
Description		
If the Power Amp temperature exceeds a preset temperature threshold (70°C), the CMI reports this alarm.		
Possible Causes		
The PA is operating too hot		
Alarm: <i>Downstream Temperature Warning</i>	Fault: XCVR	Recovery: N/A - Advisory Alarm
Description		
If the downstream temperature exceeds a preset temperature threshold (70°C), the CMI reports this alarm.		
Possible Causes		
The DS CCA is operating too hot		
Alarm: <i>Upstream Temperature Warning</i>	Fault: XCVR	Recovery: N/A - Advisory Alarm
Description		
If the upstream temperature exceeds a preset temperature threshold (70°C), the CMI reports this alarm.		
Possible Causes		
The U/S CCA is operating too hot		
Alarm: <i>Cold Start Error</i>	Fault: CMI; PA	Recovery:
Description		
If the CMI temperature is lower than a preset temperature threshold (-20°C) when the Power Amp is activated, the CMI reports this alarm and then waits until the temperature rises above the cold temperature threshold to turn on the Power Amp.		
Possible Causes		
CMI internal temperature is < -20° C at Power Amplifier power on		

Table 5-4. CMI Alarm Messages (Continued)

Alarm: <i>Upstream Continuity Alarm</i>	Fault: CMI; Cable Plant	Recovery: Check the Upstream for particular sector and node for the CMI alarming (see Table 5-18).
Description		
<ul style="list-style-type: none"> • The CMI US Continuity Alarm is Enable/Disable selectable in the CMI Alarms dialog only when the Upstream Autogain is Enabled. • The alarm threshold is based on the signal from any one CMI not exceeding the combined noise level of all CMIs by the value of the "Ingress Threshold" set in the HIC Upstream Power dialog. • The Upstream Autogain in any CMI is suspended for any autogain cycle in which the Upstream Autogain in the HIC fails to detect sufficient signal to reliably operate in either the Primary or the Diversity channel of the CMI. • The alarm is activated for a CMI if the Upstream autogain control in the HIC fails nine consecutive times to detect sufficient signal to reliably operate in either the CMI Primary or the Diversity channel. 		
Possible Causes		
The HIC cannot find either the primary and diversity gain tones of the particular CMI. Possible excessive U/S ingress or noise on the CATV link.		
Alarm: <i>Out Of Service Alarm</i>	Fault: CMI	Recovery: Re-enable DS AGC, US AGC, Autostats, Receivers, or PA.
Description		
The CMI detects that some user defined conditions have been met. Typically, the alarm will be generated if the PA, primary receive, diversity receive, autogain or autostats have become disabled.		
Possible Causes		
CMI parameters are disabled.		

5.5.3 Manual Check and Fault Isolation Procedures

The manual check and fault isolation procedures aid the maintenance personnel in determining the cause of the fault. The procedures are performed in the active state to allow for voltage and RF signal measurements. The check and fault isolation procedures consists of:

- Primary/Expansion rack procedures to check power distribution components (Surge Suppressor and +24V Power Supply), HECU (Computer, Monitor, and Mouse), 15 MHz Distribution Assembly using commercial test equipment.
- HIC procedures to check and fault isolate to a defective fan, Power Supply, or complete HIC. These procedures are used along with the alarm messages to determine the fault.
- CMI procedures to check and fault isolate to a defective component within the CMI. Similar to the HIC procedures, these procedures are used along with the alarm messages to determine the fault.

5.5.3.1 Primary/Expansion Rack Check and Fault Isolation Procedure

The following procedures are used to locate defective components not covered by the individual alarm messages. The procedures check the rack operation in a specific sequence and are performed with the rack energized. The components checked are:

- Surge Suppressor
- +24V Power Supply, if installed
- 15 MHz Distribution Assembly

WARNING

The following procedures require working inside an energized rack. The voltages and current levels present in the rack are potentially lethal. Use extreme caution to avoid coming into contact with the +24V at the Prime Power Panel or on the 24 VDC bus bar.

5.5.3.1.1 Rack Power Check Procedure

This procedure provides instructions for checking that the rack power components are not defective. The components checked are:

- Surge Suppressor
- +24V Power Supply, if installed
- a. Ensure Surge Suppressor switch is ON and observe power indicator is lit. If power indicator is lit, proceed to step *b* for installed +24V Power Supply or step *c* for using external +24V. If power indicator is not lit:
 - 1) Ensure Surge Suppressor is connected to 115 Vac.
 - 2) Ensure Surge Suppressor circuit breaker is not tripped.
 - 3) If power indicator is still not lit, Surge Suppressor is probably defective.
- b. If installed, ensure +24V Power Supply power switch is ON, DS1 indicator is lit, and meter indicates +24V on front panel.
 - 2) If DS1 indicator is lit and meter indicates +24V, proceed to paragraph 5.5.3.1.2 for HECU check Procedure.
 - 3) If DS1 indicator is not lit and +24V is not observed on meter, ensure Power Supply is connected to Surge Suppressor 115 Vac rear outlet.
 - 4) Ensure Power Supply circuit breaker is not tripped.
 - 5) If one or all indications are incorrect, Power Supply is probably defective.
- c. Ensure +24 VDC BUSBAR POWER circuit breaker is ON.

5.5.3.1.2 HECU Check Procedure

This procedure provides instructions for checking that the HECU components are not defective. The components checked are:

- Computer
- Keyboard
- Monitor
- Mouse

5.5.3.1.2.1 Computer Check Procedure

- a. Ensure Surge Suppressor switch is ON and observe power indicator is lit.
- b. Ensure the HECU Computer is plugged into a dark colored outlet.
- c. Ensure HECU Computer is turned on and the power indicator is lit. If the power indicator is not lit, the Computer is probably defective.
- d. Ensure Computer sequences through the software routines and does not hang-up. If Computer hangs-up, the computer is probably defective.

5.5.3.1.2.2 Monitor Check Procedure

- a. Ensure +24 VDC BUSBAR POWER circuit breaker is ON.
- b. Ensure HECU Computer and Monitor are turned on and each respective power indicator is lit. If Monitor power indicator is not lit, Monitor is probably defective.
- c. Reset computer and observe that monitor displays computer self-test sequence. If monitor remains blank, monitor is probably defective.

5.5.3.1.2.3 Keyboard Check Procedure

- a. Without shutting down HECU Software, set computer power switch to OFF, and make sure the Keyboard is plugged into back of computer. Turn computer back on, and wait for computer to sequence through initialization routines.
- b. If the Keyboard still does not work properly, replace Keyboard.

5.5.3.1.2.4 Mouse Check Procedure

- a. Move mouse and ensure cursor arrow moves on screen. If cursor does not move, then mouse may be defective or the computer needs to reinitialize mouse driver.
- b. Without shutting down HECU software, set computer power switch to OFF, and ensure mouse is plugged into back of computer. Turn computer back on, and wait for computer to sequence through initialization routines.
- c. Try to move mouse again. If cursor moves, it is working properly. If cursor still does not move, replace mouse.

5.5.3.1.3 15 MHz Reference Check Procedure

This procedure provides instructions for checking the 15 MHz Distribution Assembly installed in the rack. The assembly has 16 identical output ports that are either terminated, connected to a HIC, or connected to expansion rack. This procedure assumes the 15 MHz signal is available from the BTS.

WARNING

The voltages and current levels present in the rack are potentially lethal. This procedure requires work inside the rack. Use extreme caution to avoid coming into contact with the +24V at the Prime Power Panel or on the 24 VDC bus bar.

NOTE

Removal of 15-MHz input from HICs will cause all Phase-Locked Loops (PLLs) to lose lock; the HICs will be functionally inoperative during this procedure.

- a. Disconnect 15 MHz signal input from distribution assembly and measure signal level using spectrum analyzer. Verify that the level is between 0 and -16 dBm. Note level for subsequent measurements.
- b. Reconnect 15 MHz signal input to distribution assembly.
- c. Disconnect termination or HIC cable from distribution assembly output port.
- d. Connect spectrum analyzer to distribution output port and observe 15 MHz signal level is approximately same level noted in step a (0 dB gain). If gain is incorrect, 15 MHz Distribution Assembly is defective.
- e. Reconnect termination or HIC cable to distribution assembly port.
- f. Repeat steps c through e for 15 MHz Distribution Assembly remaining ports.

5.5.3.2 HIC Checkout and Fault Isolation Procedures

The following procedure is used to locate defective components not covered by the individual alarm messages. The procedures check the HIC operation in a specific sequence. The components checked are:

- HIC
- Fan
- Power Supply

5.5.3.2.1 HIC Checkout Procedure

- a. If installed, ensure the +24V Power Supply switch is ON, DS1 indicator is lit, and meter indicates +24V on front panel.
- b. Ensure HIC switch is 1 (ON) and PWR indicator is lit.
- c. Confirm that fan is running, with air blowing into HIC.
- d. If the fan does not run and PWR indicator does not light, but +24V is connected to HIC, HIC fuses may be defective and HIC must be replaced.
- e. At HEADEND CONTROL PANEL dialog, activate (acquire) HIC for normal operation in alpha, beta and gamma sectors. If HIC cannot be acquired, verify that correct Neuron® ID is being used and that Communications cable is connected between HECU and HIC.
- f. Observe HIC LED indicators to confirm that:
 - ID is off. Lit indicators occur for approximately one (1) second when the ADD_HIC_MSG is sent to the HIC.
 - FAULT is off. A lit indicator indicates an enabled alarm fault or download condition. A flashing indicator indicates a Watch Dog Reset.
 - COMM flashes (toggles) on and off in response to data messages. (Only if CMIs are attached and Autogain or Autostats is active on at least one CMI.)

- If all LED indicators are lit and HIC cannot be acquired or communications cannot be established, HIC must be replaced.
- g. Connect a spectrum analyzer to the DOWNSTREAM TEST POINT and ensure there are Reference and Control tones at 52 MHz and 52.5 MHz.
 - h. With CDMA Power applied from the BTS, Observe 450–750 MHz CDMA signal at DOWNSTREAM TEST POINT. Ensure the CDMA signal is at the proper frequency for the channel selected. Refer to fault isolation procedures later in this section for required signal levels.
 - i. At HIC CONTROL PANEL dialog, click Get Status to update HIC status windows. Observe that all status windows update and that message queue number on HECU display increases, and then decreases, as it processes messages.
 - j. Select View Info and verify that HIC Administrative Data indicates the correct version numbers. If not, download correct version of HIC software. (See Chapter 4)
 - k. Observe the PLL Status of the HIC, and ensure all PLLs are Locked. In normal operation, no PLLs should be unlocked.
 - l. Select Comm Stats and observe that HIC COMMUNICATIONS STATISTICS dialog appears.
 - m. Click Update Stats to update current data, and confirm that data changes. Ensure that Neuron® and demodulator time-outs are less than 10% of messages.
 - n. Click OK to return to HIC CONTROL PANEL Dialog.
 - o. If HIC is suspected of being defective, perform HIC troubleshooting using procedures below before making the determination to replace the HIC.

5.5.3.2.2 HIC Fan Checkout Procedure

- a. If installed, ensure that +24V Power Supply switch is ON, DS1 indicator is lit, and meter indicates +24V on front panel.
- b. Ensure HIC switch is 1 (ON) and PWR indicator is lit.
- c. Confirm that fan is running, with air blowing into HIC.
- d. If PWR indicator is lit but fan is not running, fan is probably defective. Proceed to the HIC Fan Replacement Procedure, para. 5.3.3.2.

5.5.3.2.3 HIC Power Supply Quick Checkout Procedure

This procedure is performed whenever the HIC Power Supply is suspected of being defective or has been replaced.

- a. If installed, ensure +24V Power Supply switch is ON, DS1 indicator is lit, and meter indicates +24V on front panel.
- b. Ensure HIC switch is 1 (ON). Confirm fan is running and PWR indicator is lit.
- c. If PWR indicator is not lit but fan is running, the Power Supply is probably defective. If within warranty period, return HIC for repair. Otherwise, proceed to paragraph 5.5.3.2.4 for confirmation.

5.5.3.2.4 HIC Power Supply Detailed Checkout Procedure

This procedure is performed to confirm a defective HIC Power Supply. This procedure will void the 2-year warranty and therefore should only be done after the expiration of the warranty.

⚡ ESD CAUTION

The HIC contains a circuit card assembly that is sensitive to Electrostatic Discharge (ESD) damage. Whenever handling the HIC, use ESD precautionary procedures to minimize the risk of permanent ESD damage to circuit card components. Low relative humidity level increases the potential for damage to ESD-sensitive devices.

- a. Remove HIC from rack per paragraph 5.3.3.1.
- b. While wearing a wrist strap connected to ground, place the HIC on a static safe work bench.
- c. Loosen and remove six screws that secures bottom cover to HIC.

CAUTION

To prevent damage to the HIC, ensure +24V is connected to pin 1 and +24V return is connected to pin 2 of the PWR connector. Reversing the +24V lines will blow the soldered fuses on the circuit board.

- c. Connect external +24V power source to HIC rear panel PWR connector
- d. Set HIC switch to position 1 (ON).
- e. Confirm that fan is running. (Fan running indicates the fuses are good and +24V power is connected properly. If both fan and PWR indicator are not operating, replace HIC.)
- f. Confirm that PWR indicator is lit. (If PWR indicator is not lit, Power Supply is probably defective.)

NOTE

Do not connect meter to chassis ground, the Power Supply dc return lines are isolated from chassis ground.

- g. On bottom side of HIC, measure voltages between the following power supply pins (Figure 5-14):
 - Pin 1 (+24V) and Pin 2 (+24V return) for +24 +/-3V
 - Pin 4 (+15V) and Pin 5 (+15V return) for +15.00 +/-0.15V
 - Pin 6 (+8V) and Pin 7 (+8V return) for +8.00 +/-0.08V
 - Pin 8 (+5V) and Pin 9 (+5V return) for +5.00 +/-0.05V
 - Pin 10 (-15V) and Pin 11 (-15V return) for -15.00 +/-0.15V

- h. Set HIC switch to position 0 (OFF) and disconnect +24V power source from HIC rear panel PWR connector.

NOTE

Individual components of the HECU have a two-year warranty. Any attempt to repair and/or break the seal to gain access to the internal subassemblies of a HECU component will void the warranty for the component. During the warranty period, a suspected defective HECU component should be returned to the seller for replacement or repair.

- i. If Supply is defective, replace the supply and recheck voltages before installing covers on HIC.
- j. Using six screws, secure bottom cover to HIC.
- k. Install and connect repaired HIC in rack per paragraph 5.3.3.1.

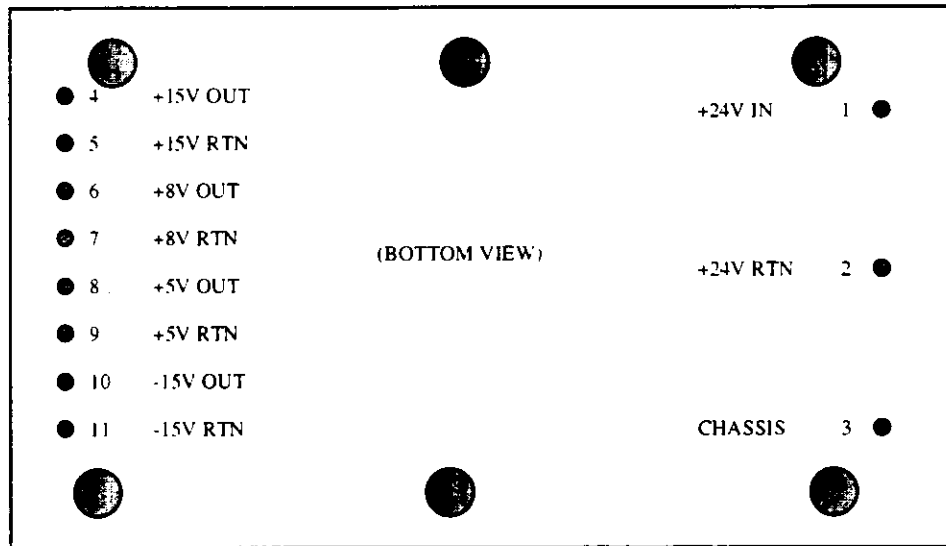

Figure 5-14. HIC Power Supply Pin Orientation

5.5.3.2.5 HIC Fault Isolation Procedures

HIC fault isolation procedures are provided in the tables below, as follows:

NOCC/HECU Operator Checks for HIC Alarms	Table 5-5
HIC Downstream Reference and Control Tones Output	Table 5-6
HIC Downstream CDMA Signals	Table 5-7
BPSK Tone Levels	Table 5-8
CMI Upstream Primary and Diversity Pedestal Measurement	Table 5-9
HIC Downstream CDMA Input Power	Table 5-10
HIC Upstream CDMA Output Power	Table 5-11

Table 5-5. NOCC/HECU Operator Checks for HIC Alarms

PLL(s) Out of Lock

Step	Normal Indication	Abnormal Indication
At HIC CONTROL PANEL, note number of PLLs unlocked; select <i>View Status</i> for details.	All PLLs Locked.	If all PLLs unlocked, probable defective 15 MHz output from BTS, or defective 15 MHz cable connection between BTS and HIC. If only some PLLs unlocked, probable defective HIC, or low 15 MHz reference level.

Alpha/Beta/Gamma DS CDMA Power Out of Range

Step	Normal Indication	Abnormal Indication
1. At the HIC CONTROL PANEL, check Alpha/Beta/Gamma DS CDMA Power (HIC CDMA input power from the BTS).	CDMA Power (dBm): Unloaded -9 to -2 65% Pole -2 to +5 Open alarm and review details. Note the power reading. Clear alarm and see if it alarms again. If border line, call Cell tech to adjust power out of Cell.	Power level is out of range in any sector, or there is no power reading (dashed lines displayed). Go to next step
2. Check status of Cell associated with the alarming HIC.	Alpha/Beta/Gamma face of cell is normal and the cell is providing CDMA output to the associated HIC. Go to next step.	Probable defective BTS CDMA output. Cell Alpha/Beta/Gamma face is not functional

Downstream Power Range Error

Step	Normal Indication	Abnormal Indication
1. At HEADEND CONTROL PANEL, select Alarms/Show Open Alarms and review details of this alarm; note reported output power level.	DS Output Power (dBmV) Unloaded +33 to +44 65% Pole +40 to +50 If normal, go to next step.	If output power is low, check DS CDMA Power level input to the HIC(see Table 5-11). Otherwise, continue with next step.
2. At the HIC CONTROL PANEL, note status of the following: • DS ATTN • DS Output • Reference Tone • Control Tone	DS ATTN: 0 to 44 dB DS Output: Enable Reference Tone Enable Control Tone Enable If all indications are normal, go to next step.	If DS Output and/or Ref/Ctrl Tones are disabled, select related <i>Control</i> button and re-enable. Go to next step.
3. Observe alarms for recurrence of this alarm.	Alarm does not recur. Problem solved	Check DS CDMA Power (see above); if input levels are within range, probable defective HIC.

Table 5-6. HIC Downstream Reference and Control Tones Output

Step	Normal Indication	Abnormal Indication
1. At HIC CONTROL PANEL, ensure that <i>Reference Tone</i> and <i>Control Tone</i> are enabled.		
2. Connect spectrum analyzer to Downstream Test Point (75 Ω).		
3. Set spectrum analyzer as follows and measure power level: <ul style="list-style-type: none"> • Center Freq. 52 MHz • 10 dB/div • Span 10 MHz 	See Figure 5-15.	
4. Peak Search or Marker to 52.5 MHz and measure power level.		
5. Determine if HIC output power levels are within range. (Measurements at test point are 20 dB down.)	Ref/Ctrl Tones at test point Max. +30 dBmV Min. +20 dBmV (adj. values for 20 dB test port attenuation) If both tones are in range, go to next step.	If either tone is less than +20 dBmV, adjust Ref/Ctrl attenuation. If attenuation cannot be adjusted to bring tone levels in range, replace HIC.
6. Using spectrum analyzer, measure Ref and Ctrl tone levels (52 and 52.5 MHz) at headend from DS laser test port.		
7. Set spectrum analyzer Center Freq. to CATV Channel 2 and measure level at laser test port.		
8. Compare Ref/Ctrl tone levels with Channel 2 level.	Both Ref and Ctrl tones are 15 dB \pm 5 dB below Channel 2 level. Go to DS CDMA Signals procedure (Table 5-7).	If one or both tones is less than or greater than 15 dB \pm 5 dB below Channel 2 level, adjust Ref/Ctrl attenuation. If HIC levels are within range, then adjustment needs to be made between HIC and HE DS laser.

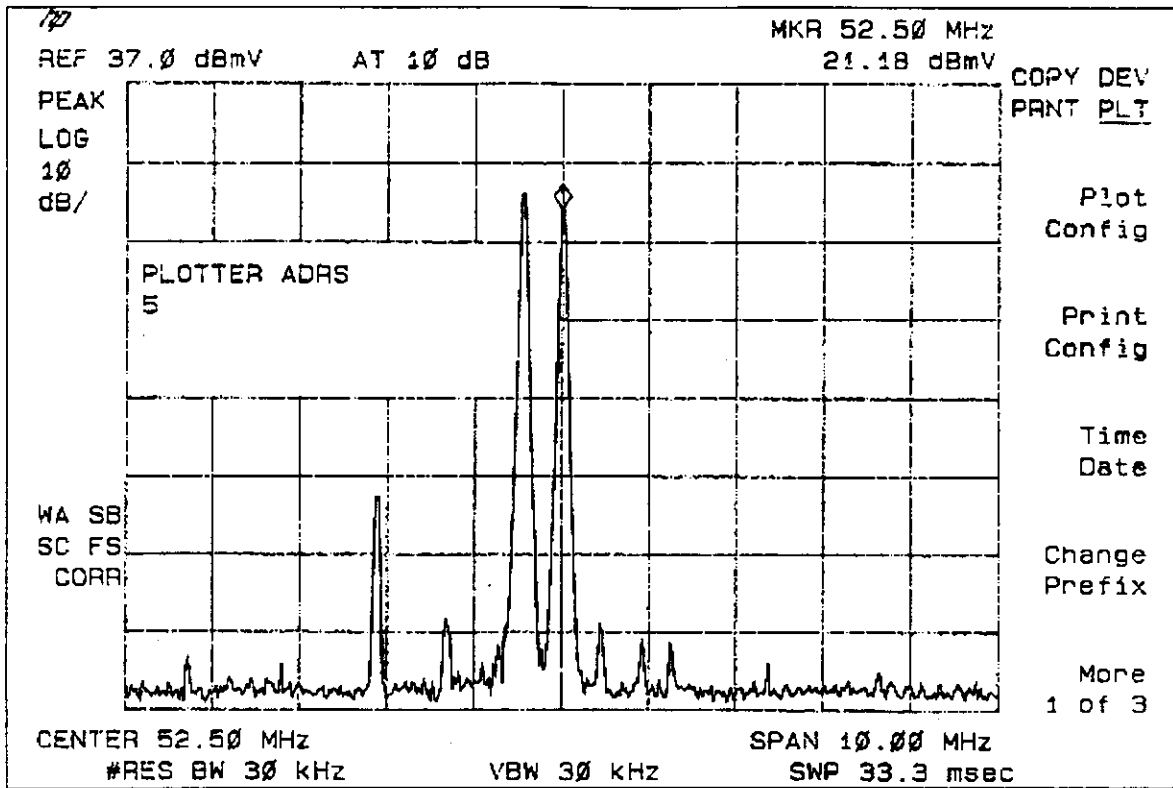

Figure 5-15. HIC Downstream Reference and Control Tones

Table 5-7. HIC Downstream CDMA Signals

Step	Normal Indication	Abnormal Indication
1. At HIC CONTROL PANEL, ensure that <i>DS Output</i> is enabled.		
2. Connect spectrum analyzer to HIC Downstream Test Port (75 Ω).		
3. Set spectrum analyzer as follows and measure power level: <ul style="list-style-type: none"> • Center Freq: DS CDMA Channel (e.g. CATV Ch. 77 ≈ 541.15 MHz) • 2 dB/division • Span 6 MHz • Resolution BW 1.25 MHz (or 30 kHz) 		
4. Adjust Span and/or center frequency so that DS CDMA pedestals for all three sectors can be seen.	See Figure 5-16.	
5. Enable Video Avg and set for 100-sample averages.		

Table 5-7. HIC Downstream CDMA Signals (Continued)

Step	Normal Indication	Abnormal Indication																		
6. For each DS CDMA sector, set display line at top of pedestal and measure power level at line.	All three DS CDMA sector pedestals should be balanced within 1 dB. Go to next step.	All DS CDMA sector pedestals are not present or balanced. go to step 11.																		
7. Determine if CDMA power levels are within range.	<p>Single CDMA carrier, 1.25 MHz Resolution Bandwidth (RBW)</p> <table border="0"> <tr> <td></td> <td style="text-align: center;"><u>65% Pole</u></td> <td style="text-align: center;"><u>Pilot Only</u></td> </tr> <tr> <td>Max.</td> <td style="text-align: center;">+30 dBmV</td> <td style="text-align: center;">+23 dBmV</td> </tr> <tr> <td>Min.</td> <td style="text-align: center;">+20 dBmV</td> <td style="text-align: center;">+13 dBmV</td> </tr> </table> <p>Single CDMA carrier, 30 kHz RBW</p> <table border="0"> <tr> <td></td> <td style="text-align: center;"><u>65% Pole</u></td> <td style="text-align: center;"><u>Pilot Only</u></td> </tr> <tr> <td>Max.</td> <td style="text-align: center;">+14 dBmV</td> <td style="text-align: center;">+7 dBmV</td> </tr> <tr> <td>Min.</td> <td style="text-align: center;">+4 dBmV</td> <td style="text-align: center;">-3 dBmV</td> </tr> </table> <p>If all levels are within range, go to next step.</p>		<u>65% Pole</u>	<u>Pilot Only</u>	Max.	+30 dBmV	+23 dBmV	Min.	+20 dBmV	+13 dBmV		<u>65% Pole</u>	<u>Pilot Only</u>	Max.	+14 dBmV	+7 dBmV	Min.	+4 dBmV	-3 dBmV	If any level is not within range, go to step 11.
	<u>65% Pole</u>	<u>Pilot Only</u>																		
Max.	+30 dBmV	+23 dBmV																		
Min.	+20 dBmV	+13 dBmV																		
	<u>65% Pole</u>	<u>Pilot Only</u>																		
Max.	+14 dBmV	+7 dBmV																		
Min.	+4 dBmV	-3 dBmV																		
8. Using spectrum analyzer, measure DS CDMA levels at headend from DS laser test port. Record level.	Measurements show no unexpected loss between the HIC output and CATV HE DS laser.	Measurements show unexpected loss between the HIC output and CATV HE DS laser. Check RF cable connections between HIC output and CATV HE DS laser input to isolate fault																		
9. Set spectrum analyzer Center Freq. to CATV Video carrier adjacent to CDMA channel and measure level at laser test port.																				
10. Compare CDMA levels with adjacent video reference level.	CDMA levels measured in 1.25 MHz RBW are 15 dB down from adjacent video reference carrier. Problem is downstream of CATV input.	CDMA levels measured in a 1.25 MHz RBW are not 15 dB down from video reference. Adjust HIC DS CDMA attenuation while maintaining appropriate HIC output levels (refer to step 7).																		
11. Measure HIC input levels from BTS. **NOTE: Measurement of DS CDMA input power to the HIC will disrupt service since the DS input cable needs to be disconnected (unless there is an external coupler in line to take DS measurements).	<p>HIC DS input levels are within the range:</p> <p>CDMA Carrier, 1.25 MHz RBW</p> <table border="0"> <tr> <td></td> <td style="text-align: center;"><u>65% Pole</u></td> <td style="text-align: center;"><u>Pilot Only</u></td> </tr> <tr> <td>Max:</td> <td style="text-align: center;">+5.0 dBm</td> <td style="text-align: center;">-2.0 dBm</td> </tr> <tr> <td>Min:</td> <td style="text-align: center;">-2.0 dBm</td> <td style="text-align: center;">-9.0 dBm</td> </tr> </table> <p>CDMA Carrier, 30 kHz RBW</p> <table border="0"> <tr> <td></td> <td style="text-align: center;"><u>65% Pole</u></td> <td style="text-align: center;"><u>Pilot Only</u></td> </tr> <tr> <td>Max:</td> <td style="text-align: center;">-12.7 dBm</td> <td style="text-align: center;">-19.7 dBm</td> </tr> <tr> <td>Min:</td> <td style="text-align: center;">-19.7 dBm</td> <td style="text-align: center;">-26.7 dBm</td> </tr> </table> <ul style="list-style-type: none"> • Adjust HIC CDMA DS attenuation (output of HIC) in conjunction with steps 8 thru 10 above. • If attenuation cannot be adjusted successfully, replace HIC. 		<u>65% Pole</u>	<u>Pilot Only</u>	Max:	+5.0 dBm	-2.0 dBm	Min:	-2.0 dBm	-9.0 dBm		<u>65% Pole</u>	<u>Pilot Only</u>	Max:	-12.7 dBm	-19.7 dBm	Min:	-19.7 dBm	-26.7 dBm	HIC DS input levels are not within range: Call for headend technician to adjust BTS output levels and proceed, starting with step 2 above.
	<u>65% Pole</u>	<u>Pilot Only</u>																		
Max:	+5.0 dBm	-2.0 dBm																		
Min:	-2.0 dBm	-9.0 dBm																		
	<u>65% Pole</u>	<u>Pilot Only</u>																		
Max:	-12.7 dBm	-19.7 dBm																		
Min:	-19.7 dBm	-26.7 dBm																		

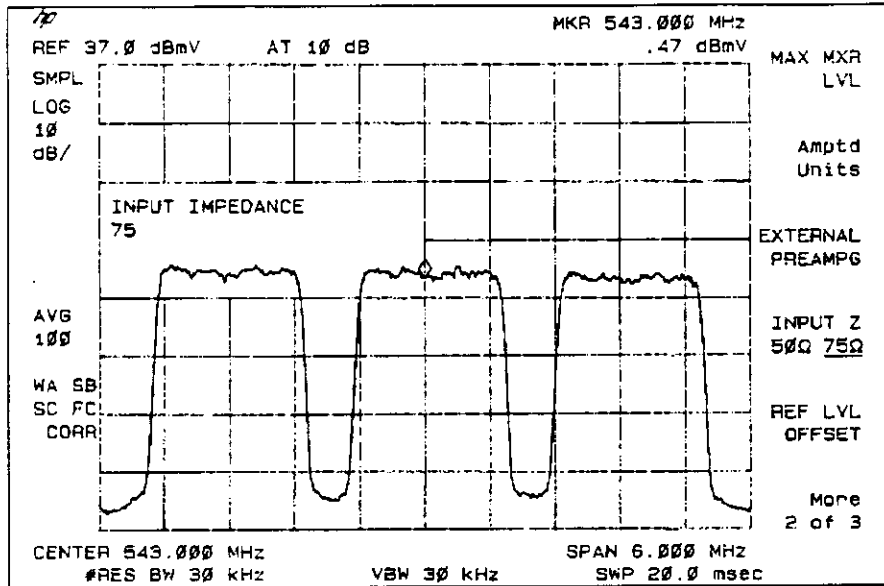

Figure 5-16. HIC Downstream CDMA Pedestals

Table 5-8. BPSK Tone Levels

Step	Normal Indication	Abnormal Indication
1. Connect Spectrum Analyzer to UPSTREAM TEST POINT (20 dB down) of HIC for sector of interest.		
2. Set the Spectrum Analyzer as follows: <ul style="list-style-type: none"> • Center Frequency (CF): Mid-frequency between Upstream Primary and Diversity pedestals CF. • Span: 6 MHz; 30 kHz RBW • Scale: 10 dB/div (2 dB/div for CMI Upstream Pedestal Measurement) • Units: dBmV (75 Ω) 		
3. Set the Spectrum Analyzer display line to -22 dBmV and measure the U/S BPSK levels.	BPSK tones for all CMIs on sector should measure -22 dBmV. Note: There is one BPSK modulation at a time for each CMI on the sector.	One or more of the BPSK tone levels is not equal to -22 dBmV. Go to next step.
4. Adjust CMI Upstream Control Attenuator for CMI in question. <ul style="list-style-type: none"> • Select CMI Group Control for sector in question. • Disable Autostats, US Autogain and DS Autogain on all CMIs on the sector • Select each CMI and select <u>Get Status</u> on CMI CONTROL PANEL: BPSK tone for selected CMI can be seen on Spectrum Analyzer. • Select <u>Upstream Power Control</u> at CMI CONTROL PANEL and adjust Control Tone ATTN until the BPSK level is -22 dBmV. • Select <u>CMI Group Control</u> and re-enable Autostats, US Autogain, and DS Autogain for all CMIs on sector. 	See Figure 5-17.	

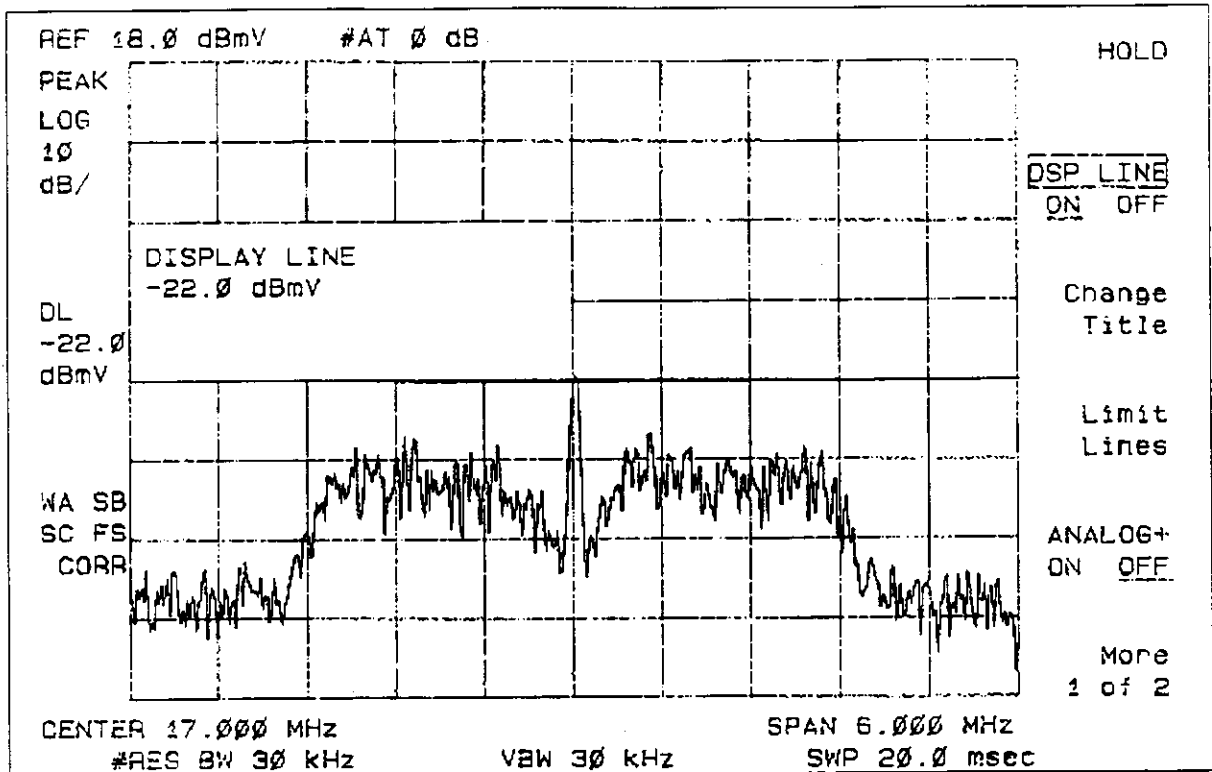

Figure 5-17. HIC Upstream BPSK Level Measurement

Table 5-9. CMI Upstream Primary and Diversity Pedestal Measurement

Step	Normal Indication	Abnormal Indication
1. Connect Spectrum Analyzer to UPSTREAM TEST POINT (20 dB down) of HIC for sector of interest.		
2. Set the Spectrum Analyzer as follows:		
<ul style="list-style-type: none"> Center Frequency (CF): Mid-frequency between Upstream Primary and Diversity pedestals CF. Span: 6 MHz; 30 kHz RBW Scale: 10 dB/div (2 dB/div for CMI Upstream Pedestal Measurement) Units: dBmV (75 Ω) 		
3. Determine the Upstream Video Carrier level for the sector. **Note: Usually determined by measuring the Upstream status monitor level or known Upstream video carrier level.		
4. Determine the CMI Upstream pedestal setpoint for the sector. Refer to SETTING CMI REVERSE LINK SIGNAL LEVEL SETPOINT, par. 4.4.	Approximately 38 dB down from the Upstream video carrier level for a single CMI at NO LOAD (no traffic)	
5. Measure the Upstream Primary and Diversity Pedestals for the CMI in question and adjust as necessary. Refer to SETTING CMI REVERSE LINK SIGNAL LEVEL SETPOINT, par. 4.4.		

Table 5-10. HIC Downstream CDMA Input Power

Step	Normal Indication	Abnormal Indication																		
<p>1. Set up Spectrum Analyzer as follows:</p> <ul style="list-style-type: none"> • Center Freq: S PCS Channel Frequency (PCS Ch. 250 = 1931.25 MHz) U/S PCS Channel Frequency (PCS Ch. 250 = 1851.25 MHz) • Span: 6 MHz; 30 kHz RBW (16.1 dB correction for 30 kHz) • Scale: 2 dB/division • 50 Ω input impedance • Units: dBm • Video Averaging: 100 averages 																				
<p>2. At the HIC CONTROL PANEL, check Alpha/Beta/Gamma DS CDMA Power (HIC CDMA input power from the BTS).</p>	<p>CDMA Power (dBm):</p> <table border="0"> <tr> <td>Unloaded</td> <td>-9 to</td> <td>-2</td> </tr> <tr> <td>65% Pole</td> <td>-2 to</td> <td>+5</td> </tr> </table> <p>Open alarm and review details. Note the power reading. Clear alarm and see if it alarms again. If border line call Cell tech to adjust power out of the Cell.</p>	Unloaded	-9 to	-2	65% Pole	-2 to	+5	<p>Power level is out of range in any sector, or there is no power reading (dashed lines displayed).. Go to next step</p>												
Unloaded	-9 to	-2																		
65% Pole	-2 to	+5																		
<p>3. Disconnect DS CDMA input cable from HIC for sector to be measured and connect it to spectrum analyzer input (50 Ω)</p>																				
<p>4. Measure HIC input levels from BTS. Set SA center frequency for the DS PCS Channel Freq. **Note: Measurement of DS CDMA input power to the HIC will disrupt service since the DS input cable needs to be disconnected (unless there is an external coupler in line to take DS measurements).</p>	<p>HIC DS input levels are within the range:</p> <ul style="list-style-type: none"> • Single CDMA Carrier, 1.25 MHz RBW <table border="0"> <tr> <td></td> <td><u>65% Pole</u></td> <td><u>Pilot Only</u></td> </tr> <tr> <td>Max:</td> <td>+5.0 dBm</td> <td>-2.0 dBm</td> </tr> <tr> <td>Min:</td> <td>-2.0 dBm</td> <td>-9.0 dBm</td> </tr> </table> • Single CDMA Carrier, 30 kHz RBW <table border="0"> <tr> <td></td> <td><u>65% Pole</u></td> <td><u>Pilot Only</u></td> </tr> <tr> <td>Max:</td> <td>-12.7 dBm</td> <td>-19.7 dBm</td> </tr> <tr> <td>Min:</td> <td>-19.7 dBm</td> <td>-26.7 dBm</td> </tr> </table> • Repeat as necessary to measure other sectors. 		<u>65% Pole</u>	<u>Pilot Only</u>	Max:	+5.0 dBm	-2.0 dBm	Min:	-2.0 dBm	-9.0 dBm		<u>65% Pole</u>	<u>Pilot Only</u>	Max:	-12.7 dBm	-19.7 dBm	Min:	-19.7 dBm	-26.7 dBm	<p>HIC DS input levels are not within range: Call for headend technician to adjust BTS output levels and re-measure.</p>
	<u>65% Pole</u>	<u>Pilot Only</u>																		
Max:	+5.0 dBm	-2.0 dBm																		
Min:	-2.0 dBm	-9.0 dBm																		
	<u>65% Pole</u>	<u>Pilot Only</u>																		
Max:	-12.7 dBm	-19.7 dBm																		
Min:	-19.7 dBm	-26.7 dBm																		

Table 5-11. HIC Upstream CDMA Output Power

Step	Normal Indication	Abnormal Indication									
<p>1. Set up the Spectrum Analyzer as follows:</p> <ul style="list-style-type: none"> • Center Freq: DS PCS Channel Frequency (PCS Ch. 250 = 1931.25 MHz) U/S PCS Channel Frequency (PCS Ch. 250 = 1851.25 MHz) • Span: 6 MHz; 30 kHz RBW (16.1 dB correction for 30 kHz) • Scale: 2 dB/division • 50 Ω input impedance • Units: dBm • Video Averaging: 100 averages 											
<p>2. Disconnect HIC U/S Primary/Diversity output cable from HIC for sector to be measured.</p>											
<p>3. Connect spectrum analyzer to HIC U/S Primary/Diversity output terminal using a 50 ohm connector; set spectrum analyzer center frequency to U/S PCS Channel Freq.</p>											
<p>4. Turn on video averaging and set the display line to the average power level of the U/S pedestal.</p>	<p>See Figure 5-18.</p>										
<p>5. Determine if U/S output level is within range.</p>	<p>Assuming CMI U/S levels are balanced: Single CDMA carrier, 30 kHz RBW</p> <table border="0" style="margin-left: 20px;"> <tr> <td></td> <td style="text-align: center;"><u>65% Pole</u></td> <td style="text-align: center;"><u>Unloaded</u></td> </tr> <tr> <td>Max</td> <td style="text-align: center;">-67.8 dBm</td> <td style="text-align: center;">-72.8 dBm</td> </tr> <tr> <td>Min</td> <td style="text-align: center;">-77.8 dBm</td> <td style="text-align: center;">-82.8 dBm</td> </tr> </table> <ul style="list-style-type: none"> • For each sector, the primary and diversity U/S levels out of the HIC should be balanced. 		<u>65% Pole</u>	<u>Unloaded</u>	Max	-67.8 dBm	-72.8 dBm	Min	-77.8 dBm	-82.8 dBm	<p>The levels are not within the specified range. If level needs to be adjusted, change the HIC U/S Attenuator for the sector being measured.</p> <p>The HIC U/S primary and diversity pedestals are not balanced for the sector. Replace the HIC.</p>
	<u>65% Pole</u>	<u>Unloaded</u>									
Max	-67.8 dBm	-72.8 dBm									
Min	-77.8 dBm	-82.8 dBm									

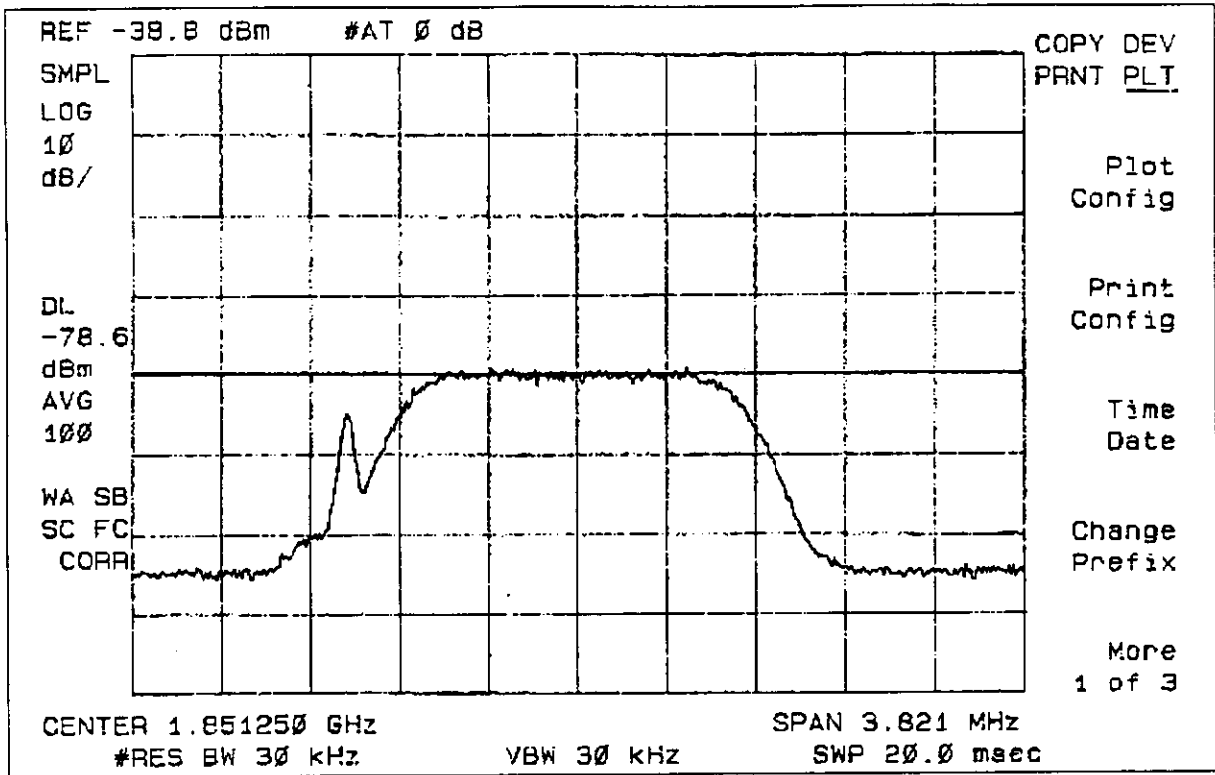

Figure 5-18. HIC Upstream Output with Video Averaging

5.5.3.3 CMI Check and Fault Isolation Procedure

The following procedures provide test measurement instructions to aid in fault isolation to a defective component in the CMI along with the various error messages that will be displayed on the HECU monitor. Figure 5-19 is a simplified functional diagram that supports the procedural instructions.

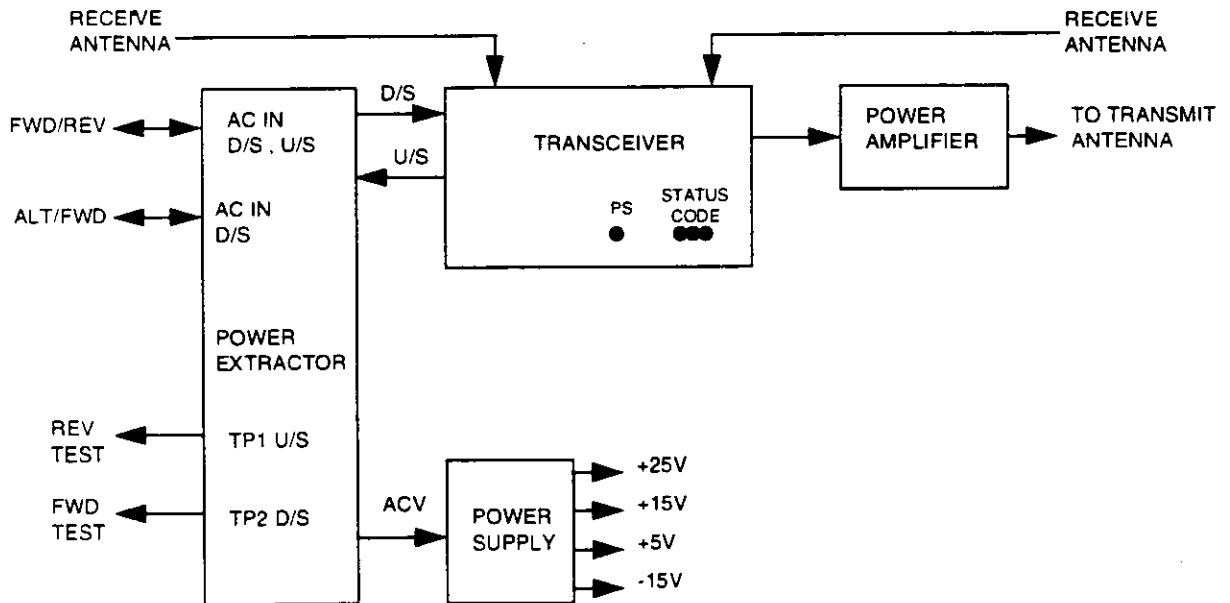

Figure 5-19. Simplified CMI Functional Diagram

5.5.3.3.1 CMI Component Access Procedure

This procedure provides instructions for gaining access to the internal CMI replaceable components. Figure 5-6 shows the location of each component. Subsequent fault isolation procedures are performed with the AC power connected to the CMI.

WARNING

Potentially dangerous High Voltage exists on the AC power cable to the CMI Assembly that could cause bodily injury or even death. Use extreme care and required safety precautions while working on the CMI.

ESD CAUTION

The CMI contains circuit card assemblies that are sensitive to Electrostatic Discharge (ESD) damage. Whenever handling the CMI, use ESD precautionary procedures to minimize the risk of permanent ESD damage to circuit card components. Low relative humidity level increases the potential for damage to ESD-sensitive devices.

- a. Loosen eight captive bolts that secure CMI cover to gain access to internal CMI replaceable components.
- b. Follow standard maintenance practices for personnel and equipment safety. Internal replaceable components are identified as ESD sensitive. Always wear wrist strap for servicing the CMI Assembly.
- c. Proceed to individual CMI measurement procedures for aid in fault isolation to the defective CMI component.
- d. Ensure appropriate HIC and CMI are active.

5.5.3.3.2 CMI Voltage Test Point Measurements Procedure

This procedure provides test measurement instructions for measuring the CMI AC and DC test points. Figure 5-20 shows the location of the measurement test points on the CMI Power Supply.

WARNING

Potentially dangerous High Voltage exists on the AC power cable to the CMI Assembly that could cause bodily injury or even death. Use extreme care and required safety precautions while working on the CMI.

- a. Ensure CMI Assembly is open to gain access to AC and DC test points on Power Supply.
- b. Using a multimeter, measure voltage between AC and RTN test points for 45–90 Vac (Quasi square wave). If voltage is incorrect, check AC voltage input to CMI and/or Power Extractor is probably defective. If voltage is missing, check Power Extractor and Power Supply input connector (Figure 5-10) for proper configuration setup for the CMI location.

- c. Using a multimeter, measure voltage between following test points:
 - +25V and RTN for +25.0 +/- 0.9V
 - +15V and RTN for +15.0 +/- 0.6V
 - -15V and RTN for -15.0 +/- 0.6V
 - +5V and RTN for +5.0 +/- 0.1V.
- d. If all voltages are missing, check fuse on Power Supply or ac input connector for proper configuration.
- e. If any voltage is incorrect or missing, Power Supply is probably defective.
- f. Replace defective component and return CMI to normal operation.

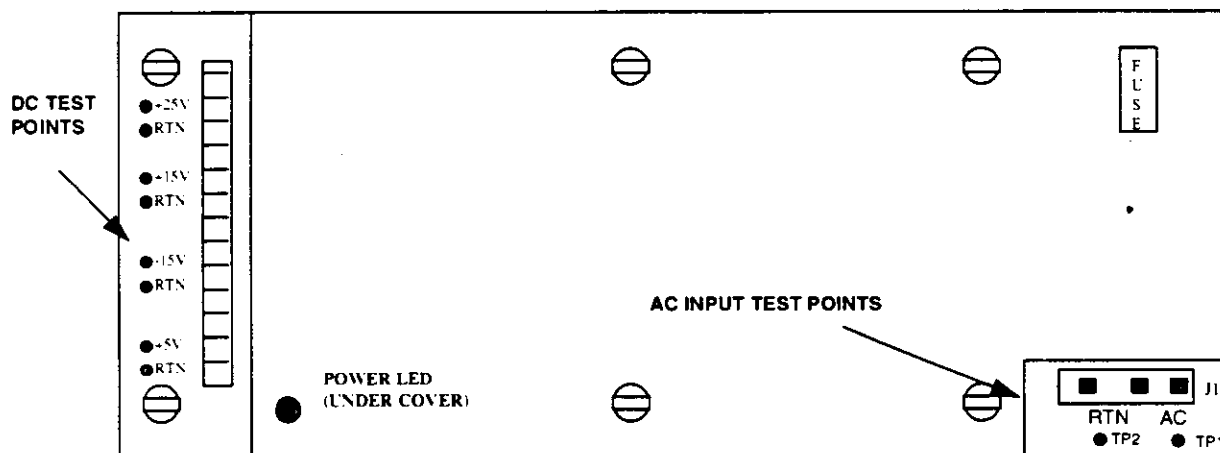

Figure 5-20. Power Supply Measurement Test Points

5.5.3.3.3 ***CMI Transceiver Module LED Indicators***

This procedure provides a truth table for interpreting the CMI Transceiver Module LED indicators in association with the CMI Alarm Messages.

WARNING

Potentially dangerous High Voltage exists on the AC power cable to the CMI Assembly that could cause bodily injury or even death. Use extreme care and required safety precautions while working on the CMI.

ESD CAUTION

The CMI contains circuit card assemblies that are sensitive to Electrostatic Discharge (ESD) damage. Whenever handling the CMI, use ESD precautionary procedures to minimize the risk of permanent ESD damage to circuit card components. Low relative humidity level increases the potential for damage to ESD-sensitive devices.

- a. Ensure CMI Assembly is open to gain access to LED indicators on Transceiver Module.
- b. Observe PS and STATUS CODE indicators on Transceiver Module light.
- c. If all four indicators are off, +5V is missing on Downstream CCA and/or Transceiver Module is defective. Ensure Power Supply is functioning properly per paragraph 5.6.3.3.2
- d. If PS indicator is lit, +5V is operating on Downstream CCA.
- e. Observe STATUS CODE indicators are not lit. If STATUS CODE indicators are lit per truth table (Table 5-12), proceed to Table 5-4 for CMI alarms.

Table 5-12. CMI Transceiver Module LED Indicator Truth Table

DS1	DS2	DS3	CMI ALARMS
off	off	off	None
on	off	off	Checksum Error
on	off	off	Waiting in Download
on	off	off	EEPROM Write Failure
off	on	off	PLLs Out of Lock
on	on	off	No Response Error
on	on	off	Communications Time Out
off	off	on	Power Amplifier Temperature Alarm
off	off	on	Upstream Temperature Alarm
off	off	on	Downstream Temperature Alarm
on	off	on	Downstream Output Power Out of Range
off	on	on	Upstream Power Out of Range
on	on	on	Power Amplifier Failure
on	on	on	Watchdog Reset
on	on	on	Reset
on	on	on	Upstream Frequency Mismatch
on	on	on	Power Amplifier Temperature Warning
on	on	on	Downstream Temperature Warning
on	on	on	Upstream Temperature Warning
on	on	on	Cold Start Alarm

5.5.3.3.4 CMI Upstream/Downstream Signal Input

This procedure provides measurement instructions for observing the presence of the Upstream and Downstream signals at the CMI Power Extractor. The measurement is not intended to be used as an absolute test measurement but is used to detect a possibility of catastrophic failure.

WARNING

Potentially dangerous High Voltage exists on the AC power cable to the CMI Assembly that could cause bodily injury or even death. Use extreme care and required safety precautions while working on the CMI.

- a. Remove DNTEST test point CATV plug from the CMI.
- b. Insert a Long Reach Test Point Adapter through access hole to mate with Power Extractor test point.
- c. Connect Type F test cable between the Long Reach Test Point Adapter and spectrum analyzer.
- d. Observe that Downstream signal at DNTEST test point is present (nominal -17 dBmV). If Downstream signal is missing and/or excessively low, Power Extractor, Cable Plant or HIC is probably defective.
- e. Remove the Long Reach Test Point Adapter from DNTEST test point, install and torque the CATV plug 35–40 in.-lb. in DNTEST port on the CMI.
- f. Remove UPTEST test point CATV plug from the CMI.
- g. Insert a Long Reach Test Point Adapter through access hole to mate with Power Extractor test point.
- h. Connect Type F test cable between the Long Reach Test Point Adapter and spectrum analyzer.
- i. Observe that Upstream signal at UPTEST test point is present (approximately +30 dBmV). If Upstream signal is missing and/or excessive low, Power Extractor or Transceiver Module is probably defective.
- j. Remove the Long Reach Test Point Adapter from UPTEST test point, install and torque the CATV plug 35-40 in.-lb. in UPTEST port on the CMI.

5.5.3.3.5 CMI Fault Isolation Procedures

CMI fault isolation procedures are provided in the figure and tables below, as follows:

Operator Fault Isolation Procedure for <i>CMI Not Responding</i>	Figure 5-21
Forward Link Continuity Test Procedure	Table 5-13
Cable Tilt Test Procedure	Table 5-14
Forward Link Reference and Control Tones Test Procedure	Table 5-15
CMI Power Configuration Procedure	Table 5-16
Reverse Link Test Procedure	Table 5-18

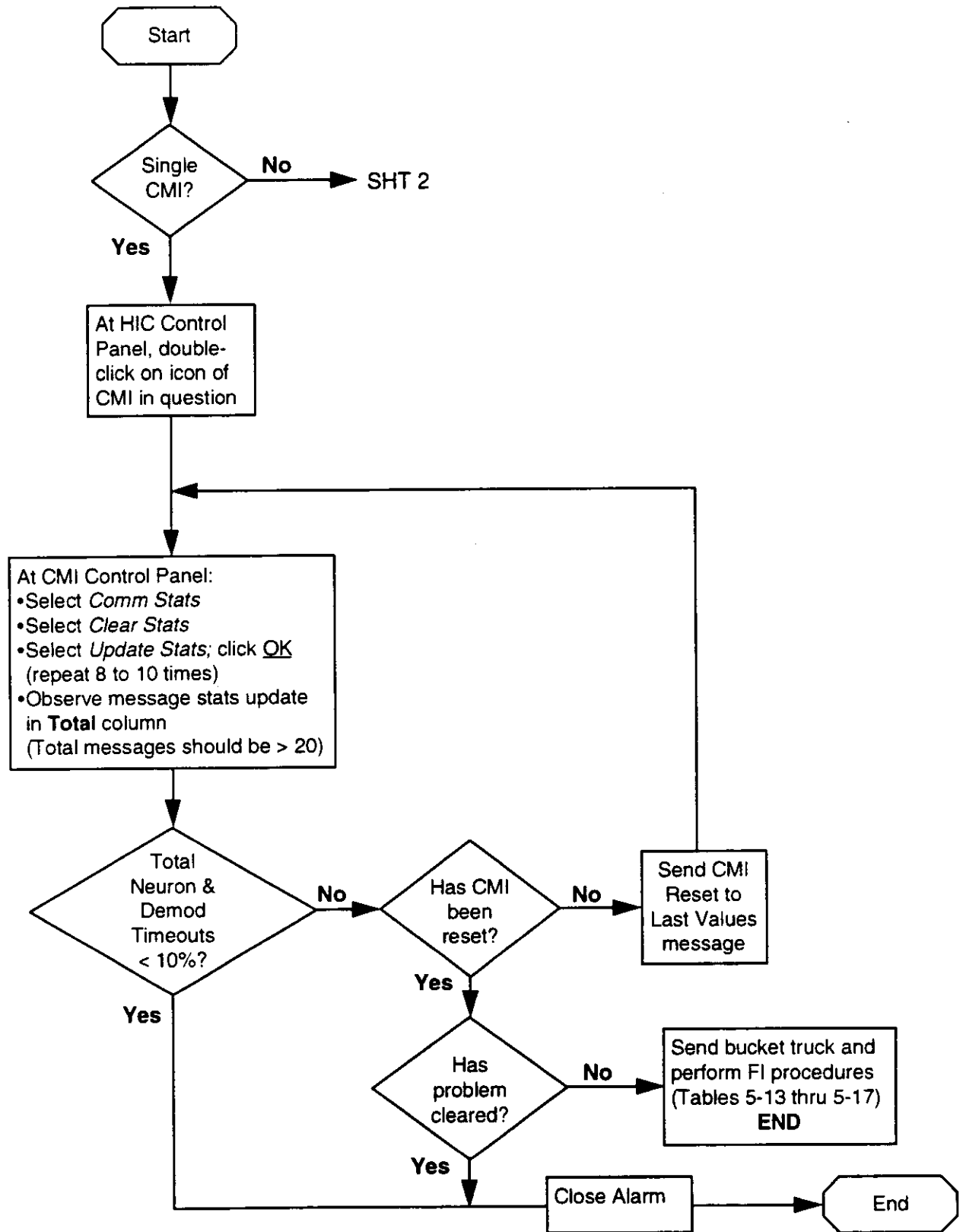

Figure 5-21. Operator Fault Isolation Procedure for CMI Not Responding Alarm

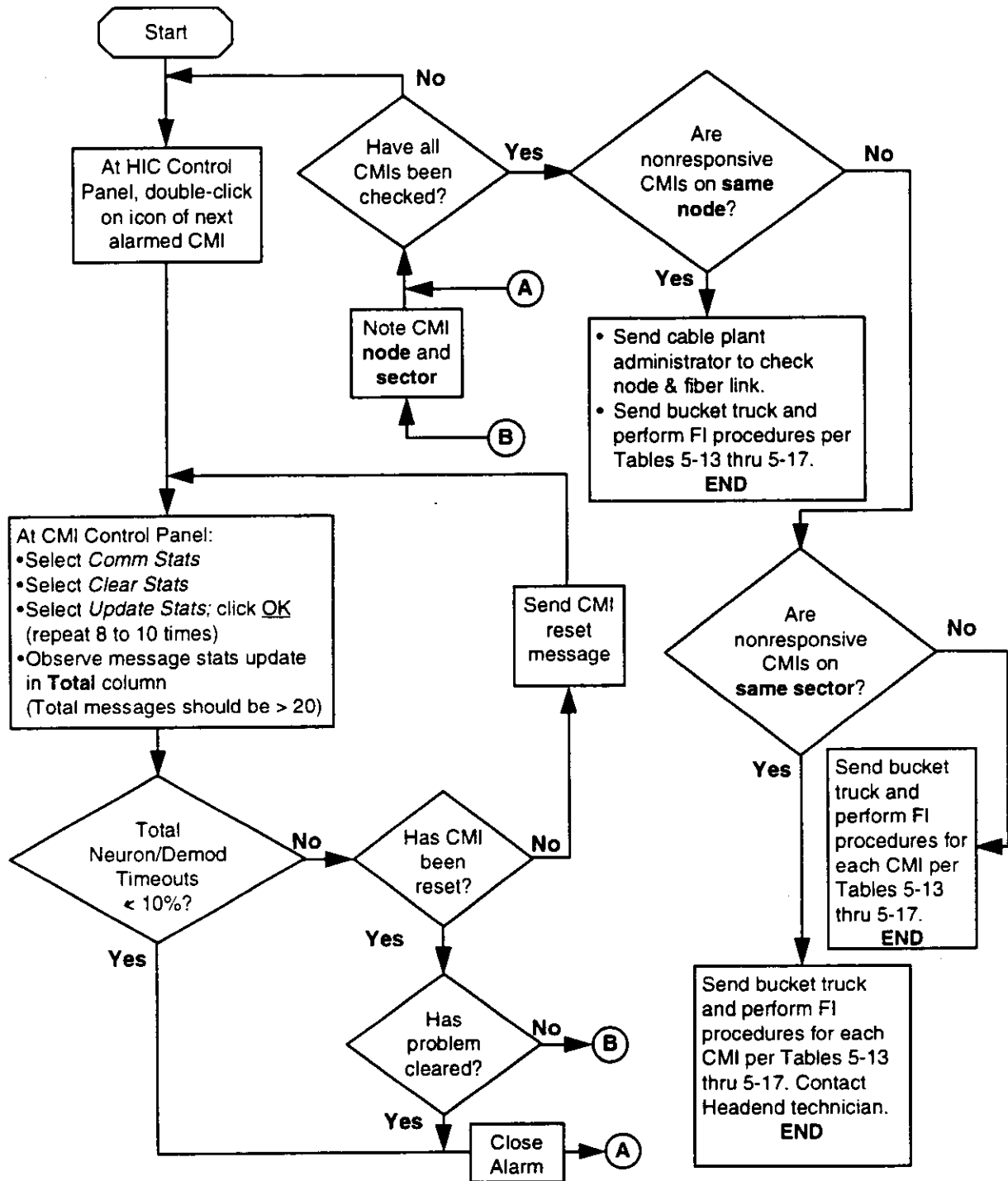

Figure 5-16. Operator Fault Isolation Procedure for CMI Not Responding Alarm (Sheet 2)

Table 5-13. Forward Link Continuity Test Procedure

Step	Normal Indication	Abnormal Indication
1. Open CMI assembly per par. 5.5.3.3.1.		
2. Observe LED on Power Supply.	LED is lit: Go to step 3.	LED is not lit: Check Power Supply voltage test points per para. 5.6.3.3.2 and Figure 5-22 to isolate fault between Power Supply, Power Extractor, and KS port connections.
3. Observe green PS LED on Transceiver.	LED is lit. Go to step 4.	LED is not lit: Check voltages at harness connector per Figure 5-22 to isolate fault between harness and Transceiver.
4. Observe status LEDs on Transceiver when CMI Reset message is sent from HECU.	LEDs blink several times then remain steady (ON or OFF): There is FWD Link Continuity - Go to next procedure and check the cable tilt at the CMI.	LEDs do not blink: There is FWD Link discontinuity - Perform Forward Link Reference and Control Tones Test Procedure (Table 5-15).

Table 5-14. Cable Tilt Test Procedure

NOTE

Measurement of CDMA signals in a 30 kHz RBW are 16.1 dB lower than when measured in a 1.25-MHz RBW. Ensure actual values are compared using the proper compensation for RBW.

Step	Normal Indication	Abnormal Indication								
1. Connect meter to FWDTEST port (20 dB down) per par. 5.5.3.3.4.										
2. Measure and record level of the adjacent CDMA video carrier at FWDTEST port.	<table border="0"> <tr> <td><u>Level (dBmV)</u></td> <td><u>Max</u></td> <td><u>Nom</u></td> <td><u>Min</u></td> </tr> <tr> <td></td> <td>-6</td> <td>-7</td> <td>-15</td> </tr> </table> <p>Go to next step.</p>	<u>Level (dBmV)</u>	<u>Max</u>	<u>Nom</u>	<u>Min</u>		-6	-7	-15	If adjacent CDMA video carrier level is less than -15 dBmV, contact cable plant administrator for increase in DS power level at CATV high end frequencies.
<u>Level (dBmV)</u>	<u>Max</u>	<u>Nom</u>	<u>Min</u>							
	-6	-7	-15							
3. Set meter to measure Channel 2. Measure and record level at FWDTEST port.	<table border="0"> <tr> <td><u>Level (dBmV)</u></td> <td><u>Max</u></td> <td><u>Nom</u></td> <td><u>Min</u></td> </tr> <tr> <td></td> <td>-6</td> <td>-7</td> <td>-15</td> </tr> </table>	<u>Level (dBmV)</u>	<u>Max</u>	<u>Nom</u>	<u>Min</u>		-6	-7	-15	If Channel 2 level is less than -15 dBmV, contact cable plant administrator for increase in FWD power level.
<u>Level (dBmV)</u>	<u>Max</u>	<u>Nom</u>	<u>Min</u>							
	-6	-7	-15							
4. Determine Cable Tilt: <i>CH 2 level - (Adjacent CDMA Channel level)</i>	Cable Tilt = 0 ± 5 dB Continue with Procedure 2.3.	If Channel 2 level is more than 5 dB higher than Channel 76, the CDMA power level will be out of range. Adjust the equalizer in the Power Extractor to correct for negative tilt. If adjacent CDMA video carrier level is more than 5 dB higher than Channel 2 level, contact cable plant administrator.								

Table 5-15. Forward Link Reference and Control Tones Test Procedure

Step	Normal Indication	Abnormal Indication								
1. Connect meter to FWDTEST port (20 dB down) per par. 5.5.3.3.4.										
2. Set meter to measure 52.5 MHz. Measure and record level at FWDTEST port.										
3. Determine if Reference tone input level at the CMI is within specification (15 dB down from Channel 2)	<table border="1"> <thead> <tr> <th>Level (dBmV)</th> <th>Max</th> <th>Nom</th> <th>Min</th> </tr> </thead> <tbody> <tr> <td></td> <td>-21</td> <td>-26</td> <td>-30</td> </tr> </tbody> </table> <p>If the values measured are between -21 and -30 dBmV continue with Procedure 2.</p>	Level (dBmV)	Max	Nom	Min		-21	-26	-30	<p>If the value measured in step 3 is more than -21 or less than -30 dBmV, the level is out of spec.</p> <p>If level is <i>too high</i>, change pad on Power Extractor to bring input to nominal level.</p> <p>If level is <i>too low</i>, change pad on Power Extractor to bring input to nominal level; contact cable plant administrator to make adjustment if power level is still too low after pad change.</p> <p>See examples below.</p>
Level (dBmV)	Max	Nom	Min							
	-21	-26	-30							

Examples of Power Extractor pad changes to correct input level of Reference/Control Tone	
<p>Example 1: Level is too high</p> <p>Measured level (DS test port): -15 dBmV Current DS/FWD Pad 5 dB Max. spec. level -21 dBmV Nominal spec. level -26 dBmV Measured - nominal level = 11 dB</p> <p>Solution: Replace 5 dB pad with an increase of 11 dB which equals a 16 dB pad.</p>	<p>Example 2: Level is too low</p> <p>Measured level (DS test port): -31 dBmV Current DS/FWD Pad 0 dB Min. spec. level -30 dBmV Nominal spec. level -26 dBmV Measured - nominal level = -7 dB</p> <p>Solution: Request increased input level from cable plant administrator.</p>

Table 5-16. CMI Power Configuration Procedure

Step	Normal Indication	Abnormal Indication
1. Check power supply LED and transceiver PS LED	<p>XCVR PS LED = ON (green) PS LED = ON (green)</p> <p>CMI power configuration OK. Go to Step 4</p>	<p><i>PS ON/XCVR OFF:</i> problem with DC power - check power supply DC voltage (step 3) Probable Power Supply Harness or XCVR fault</p> <p><i>PS OFF/XCVR OFF:</i> problem with AC power - probable incorrect PE configuration, cable power supply, or CMI/Cable KS port connection fault.</p> <p>Go to next step.</p>
2. Set PE switch to OFF then to proper setting for CATV power configuration: FWD/REV or ALT/FWD.	<p>The Power Extractor type and the position of the PE switch correspond with external coaxial cable and power configuration. Go to next step.</p>	<p>Incorrect Power Extractor for the external cable configuration being used or the PE switch is in the wrong position. Change to correct setting(s). Go to next step.</p>

Table 5-17. CMI Power Configuration Procedure (Continued)

Step	Normal Indication	Abnormal Indication
3. Check Power Supply DC voltage levels per par. 5.5.3.3.2.	If all voltages are within tolerance, probable defective Transceiver.	If all voltages are missing, check Power Supply fuse. If any voltage is incorrect or missing, probable defective Power Supply.
4. Check Power Supply AC voltage level per par. 5.5.3.3.2.	45–90 Vac (60 Vac nominal). Go to next step.	Check AC input to Power Supply. If voltage is within tolerance, probable mechanical damage to connector, or defective Power Supply. If voltage is out of tolerance, probable defective Power Extractor, or low cable plant voltage.

Table 5-18. Reverse Link Test Procedure

NOTE

Measurement of CDMA signals in a 30 kHz RBW are 16.1 dB lower than when measured in a 1.25 MHz RBW. Ensure actual values are compared using the proper compensation for RBW.

Step	Normal Indication	Abnormal Indication
1. Using a signal generator, inject an upstream CATV carrier tone into the REVTEST port. Configure the signal generator to the following: Center frequency: CMI U/S Primary or Diversity pedestal frequency Output Power: +30 dBmV	Carrier should be seen at corresponding HIC U/S test port. Continuity.; problem is internal to CMI. Go to next step.	No carrier seen at corresponding HIC U/S test port. No continuity. Check cable plant components.
2. Open CMI assembly per par. 5.5.3.3.1.		
3. Replace Power Extractor using new U/S and D/S pads with same values.	CMI operates normally. Go to next step.	CMI upstream output still out of spec or absent. Replace Transceiver.
4. Reinstall original Power Extractor with new pads.	CMI operates normally. Bad pad; problem solved.	CMI upstream output still out of spec or absent. Replace Power Extractor.

5.5.3.4 **Upstream Checkout Procedures Using PING**

The PING function, initiated from the CMI CONTROL PANEL dialog, provides the capability of checking upstream (reverse) path functionality between HICs and their attached CMIs. The following paragraphs provide two checkout procedures, one for verifying upstream continuity and the other to determine the quality of the CMI tone that is used for upstream autogain control.

NOTE

To avoid any unpredictable performance conditions, it is imperative that once the PING CMI GUI has been opened, the operator does not select any other GUI control except for those controls within the PING CMI GUI (Test Signal ON, Test Signal Off, Send or Exit).

5.5.3.4.1 **Verifying Upstream Continuity**

NOTE

This procedure assumes that the CMIs have all been properly integrated and the Upstream pedestal levels balanced.

- a. At HECU CONTROL PANEL dialog, select **Alarms/CMI Out Of Service Control** from menu.
- b. At CMI OUT OF SERVICE dialog, select Out Of Service Indicator OFF to disable all Out Of Service alarms, then click OK.
- c. At HECU CONTROL PANEL dialog, select the first HIC to be examined.
- d. Connect Spectrum Analyzer to the appropriate sector UPSTREAM TEST POINT on front panel of selected HIC.
- e. Set up Spectrum Analyzer as follows:
 - Center Frequency - midpoint of appropriate Sector Primary & Diversity Upstream Frequencies
 - Frequency Span - 4 MHz. (See Notes below)
 - Resolution Bandwidth - 30 kHz
 - Input - 75 Ohms.
 - Amplitude Units - dBmV, scale - 1 dB per div.
 - Input Attenuator - 0 dB.
 - Select BW and turn on Vid Avg, set for 100 samples average
 - Adjust Reference Level so that pedestal level is near mid screen.

NOTE

Increase the Frequency Span if the separation between Primary & Diversity is greater than 2 MHz.

NOTE

For proper system operation, each Primary US Pedestal frequency must be set at least 2 MHz away from (normally below), and not greater than 4.75 MHz away from, the related Diversity US Pedestal frequency.

- f. At HIC CONTROL PANEL dialog, select Sector and CMI to be Pinged.
- g. At CMI CONTROL PANEL dialog, select Ping.
- h. At the PING CMI dialog, select Test Signal ON and then Send.
- i. Observe Primary and Diversity pedestals on the Analyzer.
 - If US continuity from selected CMI back to HIC is OK, the PING function will be visible as a pair of tones, one in each pedestal.
 - Ping tones are placed on the left (lower frequency) side of pedestals so as to be distinguishable from CMI autogain tones which, when enabled, appear on the right (upper frequency) side of pedestals.
- j. At PING CMI Dialog, select Exit.
- k. At HECU CONTROL PANEL dialog, select **Alarms/CMI Out Of Service Control** from menu.
- l. At the CMI OUT OF SERVICE dialog, select Out Of Service Indicator ON and select all desired alarms, then click OK.

5.5.3.4.2 Determining CMI Tone Quality for Upstream Autogain Control

This procedure is provided to allow the user to the capability of determining whether existing active CMIs will operate properly when the Upstream Autogain is enabled. The CMI contains a circuit that generates an upstream tone required for Upstream Autogain operation. Using the PING capability of HECU version 1.87, this tone generator can be individually activated in any CMI to determine the quality of the tone. This procedure is intended to be performed prior to activating the Upstream Autogain on previously installed CMIs with unknown gain tones, or as a troubleshooting procedure if the gain tones from any CMIs are suspected of having failed and are causing Upstream Autogain problems. See Caution and Notes below.

CAUTION

This procedure will disrupt service on the entire HIC.

NOTE

HECU Version 1.87 is required to enable the PING function.

This procedure assumes that the CMIs have all been properly integrated and the Upstream pedestal levels balanced.

- a. At HECU CONTROL PANEL dialog, select **Alarms/CMI Out Of Service Control** from menu.

- b. At CMI OUT OF SERVICE dialog, select Out Of Service Indicator OFF to disable all Out Of Service alarms, then click OK.
- c. At the HECU CONTROL PANEL dialog, select the first HIC to be examined.
- d. At HIC CONTROL PANEL dialog, select CMI Group Ctl and *disable* all functions except Alarms for the Sector(s) that will be examined, then select OK.
- e. At HIC CONTROL PANEL dialog, select Sector to be examined.
- f. Connect Spectrum Analyzer to the appropriate sector UPSTREAM TEST POINT on front panel of selected HIC.
- g. Set up Spectrum Analyzer as follows:
 - Center Frequency - midpoint of appropriate sector Primary & Diversity Upstream Frequencies
 - Frequency Span - 4 MHz. (See Notes below)
 - Resolution Bandwidth - 30 kHz
 - Input - 75 Ohms.
 - Amplitude Units - dBmV, scale - 1 dB per div.
 - Input Attenuator - 0 dB.
 - Enable Display Line and place it at mid screen
 - Select BW and turn on Vid Avg, set for 100 samples average

NOTE

Increase the Frequency Span if the separation between Primary & Diversity is greater than 2 MHz.

For proper system operation, each Primary U/S pedestal frequency must be set at least 2 MHz away from (normally below), and not greater than 4.75 MHz away from, the related Diversity U/S pedestal frequency.

- h. At HIC CONTROL PANEL dialog, select CMI to be examined.
- i. At CMI CONTROL PANEL dialog, select Ping.
- j. At the PING CMI dialog, select Test Signal ON and then Send.
- k. Observe the Primary and Diversity pedestals on the Analyzer.
 - If US continuity from selected CMI back to HIC is OK, PING function will be visible as a pair of tones, one in each pedestal.
 - Ping tones are placed on the left (lower frequency) side of the pedestals so as to be distinguishable from CMI autogain tones which, when enabled, appear on the right (upper frequency) side of the pedestals.
- l. Observe average levels of Primary and Diversity pedestals on Spectrum Analyzer. Adjust Analyzer REF Level as required. Record levels of both pedestals.
- m. Observe levels of Primary and Diversity tones on Spectrum Analyzer using Peak Search function. Record levels of both pedestals.

- n. Calculate pedestal-to-tone deltas for Primary and Diversity. Verify that deltas are between 14 dB and 24 dB.
- o. If either delta is outside minimum or maximum limit, CMI Transceiver should be replaced prior to enabling Upstream Autogain on the sector.
- p. At the PING CMI dialog, select Exit.
- q. At CMI CONTROL PANEL dialog, select OK to exit.
- r. Repeat steps *h* through *q* to complete examination of all CMIs in the sector.
- s. Repeat steps *e* through *r* to complete the examination of all sectors for selected HIC.
- t. At HIC CONTROL PANEL dialog, select CMI Group Ctl and *enable* all functions for all Sectors that have CMIs attached, then select OK.
- u. If additional HICs are to be examined, repeat steps *c* through *t* for each HIC.
- v. At HECU CONTROL PANEL dialog, select **Alarms/CMI Out Of Service Control** from menu.
- w. At the CMI OUT OF SERVICE dialog, select Out Of Service Indicator ON and select all desired alarms, then click OK.

5.6 WIRING DATA

CMI wiring data is provided in Figure 5-22 as an aid for troubleshooting and repair.

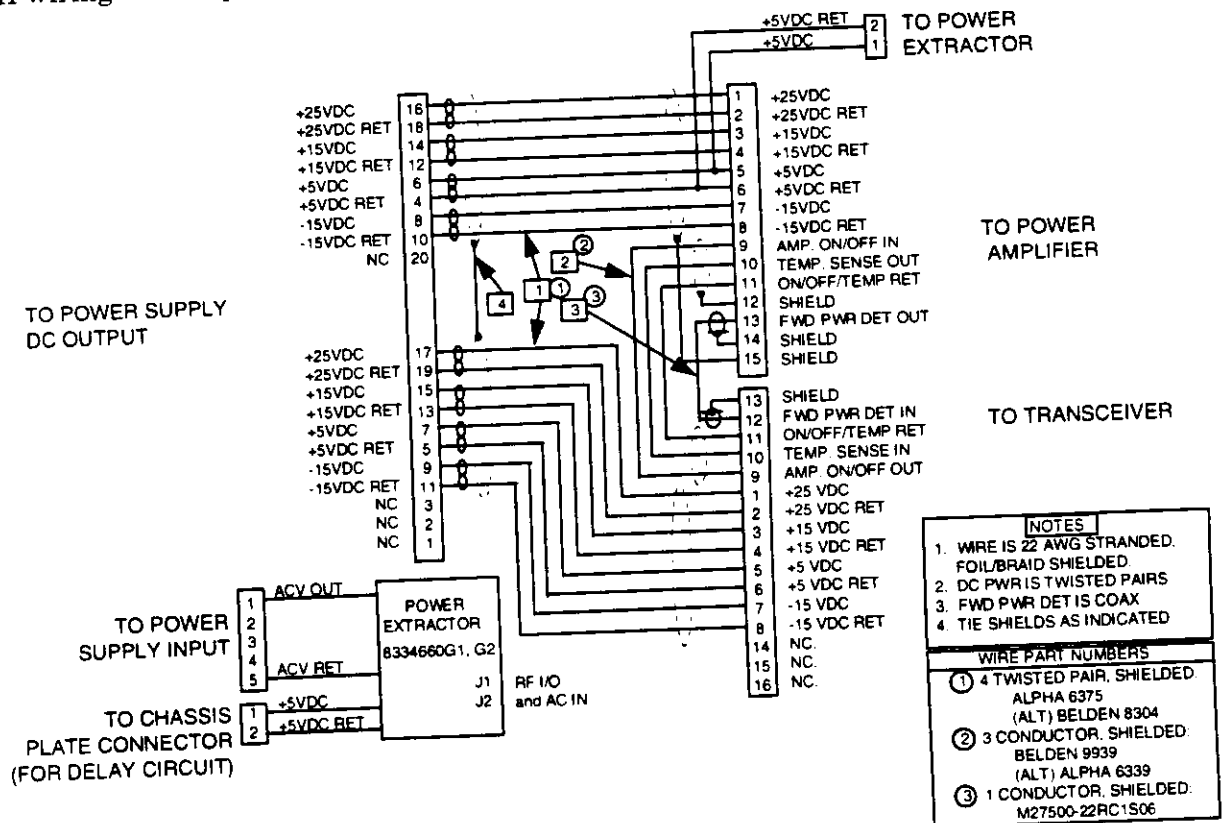

Figure 5-22. CMI Wiring Harness Diagram

