

BLUEBOX(BB-100)



The Bluetooth® word mark and logos are registered trademarks owned by Bluetooth SIG, Inc. and any use of such marks by SANGEAN ELECTRONICS INC. is under license.

Important Safety Instructions

1. Read these instructions.
2. Keep these instructions.
3. Heed all warnings
4. Follow all instructions
5. Do not use this apparatus near water.
6. Clean only with dry cloth.
7. Do not block any ventilation openings. Install in accordance with the instructions.
8. Do not install near any heat sources such as radiators, heat registers, stoves or other apparatus (including amplifiers) that produce heat.
9. Do not defect the safety purpose of the polarized or grounding type plug. A polarized plug has two blades with one wider than the other. A grounding type plug has two blades and a third grounding prong. The wide blade or the third prong are provided for your safety. If the provided plug does not fit into your outlet, consult an electrician for replacement of the obsolete outlet
 - USA version only.
10. Protect the power cord from being walked on or pinched particularly at plug, convenience receptacles, and the point where they exit from the apparatus.
11. Only use attachments/accessories specified by the manufacturer.
12. Use only with the cart, stand, tripod, bracket, or table specified by the manufacturer, or sold with the apparatus. When a cart is used, use caution when moving the cart/apparatus combination to avoid injury from tip-over.
13. Unplug this apparatus during lightning storms or when unused for long periods of time.
14. Refer all servicing to qualified service personnel. Servicing is

required when the apparatus has been damaged in any way, such as power-supply cord or plug is damaged, liquid has been spilled or objects have fallen into the apparatus, the apparatus has been exposed to rain or moisture, does not operate normally, or has been dropped.

15. To reduce the risk of fire or electric shock, Do not expose this appliance to Rain or Moisture.

16. The Shock Hazard Marking and Associated Graphical Symbol is provided on the bottom panel of unit.

17. Apparatus shall not be exposed to dripping or splashing and no objects filled with liquids, shall be placed on the apparatus.

18. For outdoors use, to avoid electric shock, use battery only during a raining day or the weather is wet.

For United States:



Cautions to the user

The changes or modifications not expressly approved by the party responsible for compliance could void the user's authority to operate the equipment.

RF exposure statements

IMPORTANT NOTE:

To comply with the FCC RF exposure compliance requirements, the antenna(s) used for this transmitter must be installed to provide a separation distance of at least 20cm (8 inches) from all persons and must not be co-located or operating in conjunction with any other antenna or transmitter. No change to the antenna or the device is permitted. Any change to the antenna or the device could result in the device exceeding the RF exposure requirements and void user's authority to operate the device.

Note:

This equipment has been tested and found to comply with the limits for a Class B digital device, pursuant to part 15 of the FCC Rules.

These limits are designed to provide reasonable protection against harmful interference in a residential installation. This equipment generates, uses and can radiate radio frequency energy and, if not installed and used in accordance with the instructions, may cause harmful interference to radio communications. However, there is no guaranty that interference will not occur in a particular installation. If this equipment does cause harmful interference to radio or television reception, which can be determined by turning the equipment off and on, the user is encouraged to try to correct the interference by one or more of the following measures:

- Reorient or relocate the receiving antenna.
- Increase the separation between the equipment and receiver.
- Connect the equipment into an outlet on a circuit different from that to which the receiver is connected.
- Consult the dealer or an experienced radio/TV technician for help.

CAUTION: These servicing instructions are for use by qualified service personnel only. To reduce the risk of the electric shock, do not perform any servicing other than that contained in the operating instructions unless you are qualified to so.

Controls

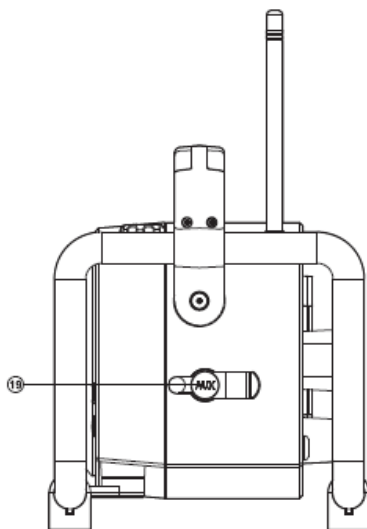
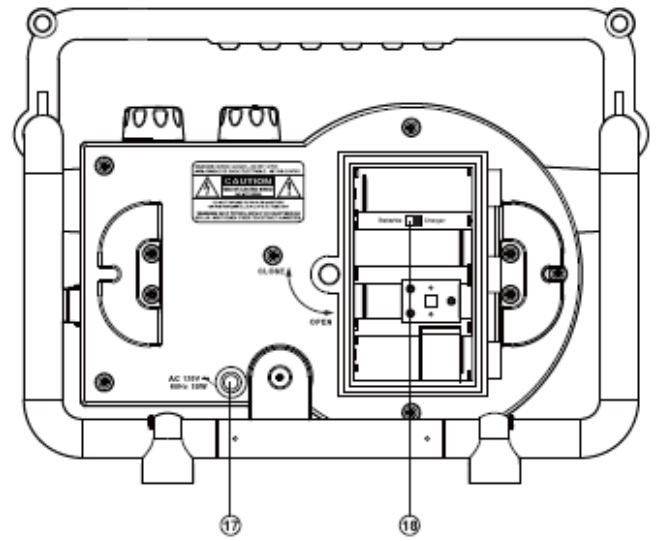
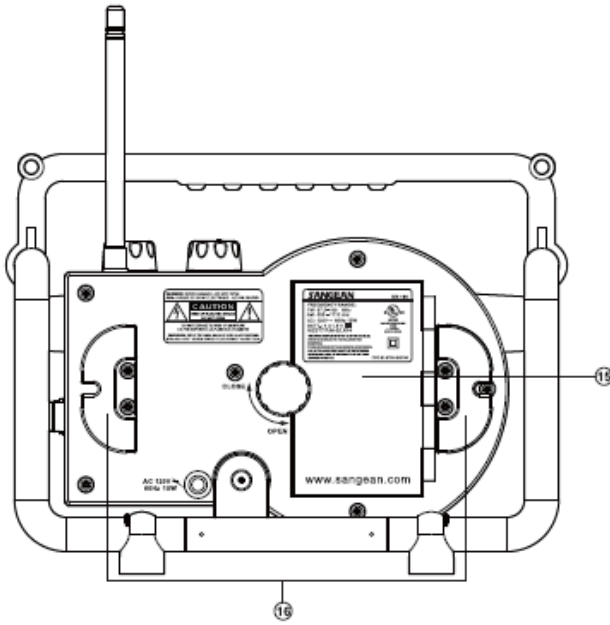
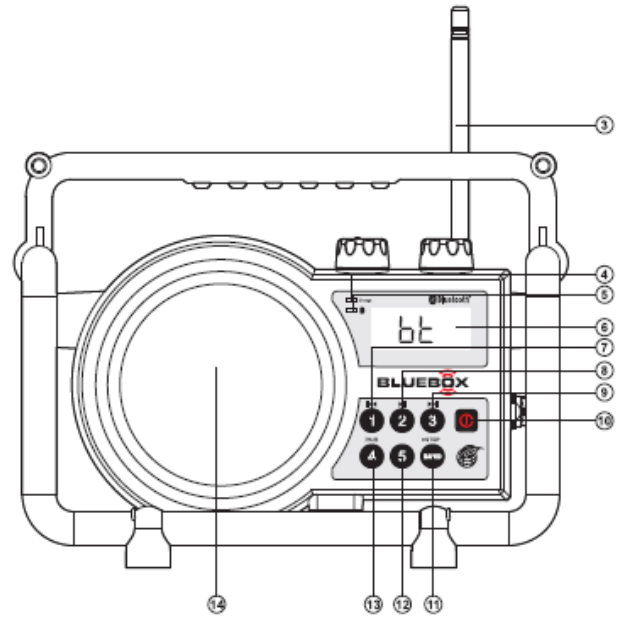
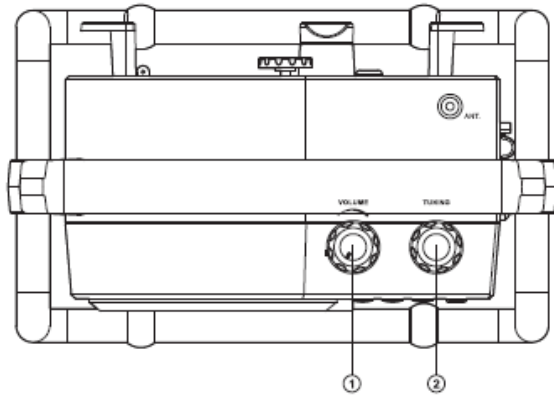

1. Volume Control knob
2. Tuning Control knob
3. FM antenna
4. Charge LED indicator
5. Bluetooth status indicator
6. LCD display
7. Preset 1/ Rewind button
8. Preset 2/ Play/Pause button
9. Preset 3/ Fast-forward button
10. Power button
11. Band/Step button
12. Preset 5
13. Preset 4/ Bluetooth pairing button
14. Speaker
15. Battery Compartment
16. AC power cord storage
17. AC power cord
18. Rechargeable battery (Charger)/Normal battery (Batteries) Switch
19. Aux In socket

LCD Display

- A. Band Indicator
- B. Frequency
- C. Preset Stations
- D. Low Battery Indicator

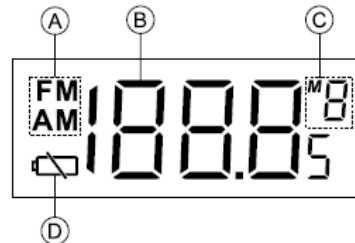

Power the radio

1. Installing the batteries, first turn battery cover fixture anti-clockwise to loosen and **open** the battery cover.

Note:

Before you insert the batteries, if you use non-rechargeable batteries, make sure the Charger/Batteries switch which located inside the battery compartment is switched to Batteries position.

If you use rechargeable batteries, make sure to switch Charger/Batteries switch to Charger position.

2. Insert 4 X C size (UM-2) battery into the compartment. Ensure

the battery is inserted in accordance with the diagram shown. Close the battery cover and fasten the fixture by turning clockwise. If the radio is not to be used for any extended period of time, it is recommended that the battery is removed from the radio. Reduced power, distortion and a “stuttering sound” or low battery sign  is flashing on the display are all signs that the batteries need replacing or recharged. (see below charge the batteries)

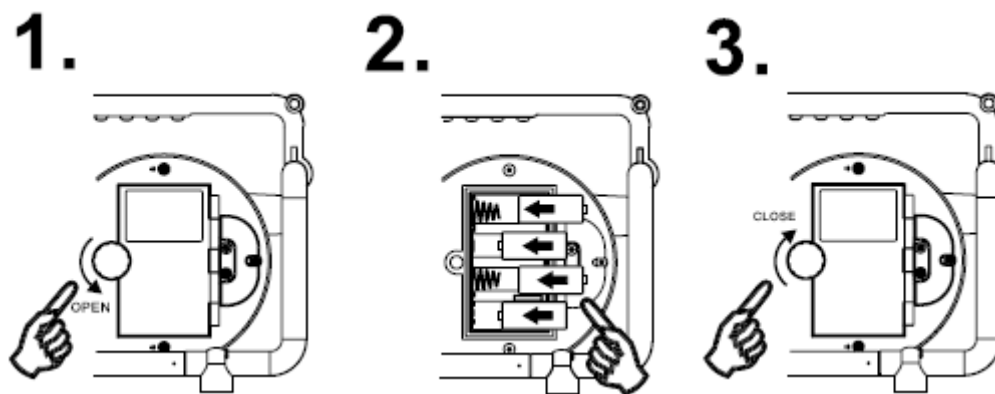

3. AC Operation

Before plug the AC power cord into the AC socket, be sure the voltage is correct. If you have batteries in the radio and connect the AC power cord into the AC socket, the batteries will automatically be disconnected.

AC power cord storage is designed to store the cord when the radio is not in use.

Charge the batteries

Reduced power, distortion and a “stuttering sound” or low battery

sign  is flashing on the display are all signs that the batteries need recharged if you use rechargeable batteries to power the radio.

Note:

The radio can be charged only when the radio is off.

Connect the AC power cord into the AC socket to charge the batteries.

Make sure the battery type switch is set to Charger position.

When the battery charge indicator LED flashes red, this indicates the batteries are charging. Charging time takes approx. **6-10 hours** depending on capacity the rechargeable batteries in use. **When the batteries are fully charged, the**

charge LED will be steady on red color.

IMPORTANT INFORMATION ON CHARGING AND USING RECHARGEABLE BATTERIES

1. Recharge the batteries in any case at least every 2 months.
2. Make sure the Battery Select switch next the battery compartment is set to the “CHARGER” position.
3. Put the batteries in the compartment whilst paying attention to the correct polarity of the batteries (+ and -).
4. First use: Charge new batteries in one continuous, uninterrupted, charge until they are full. This first charge may take longer than normal. For longer battery life it is advised to always recharge in one continuous, uninterrupted charge until batteries are full and to not recharge again whilst the batteries are still full.
5. New batteries will only reach their full capacity after some time of use (several charge – discharge cycles).
6. Leave the complete group of batteries in place inside the radio and do not use these batteries or a few of them for other purposes. This will result in a mix of (fully) charged and (partly) empty batteries. This can seriously damage the batteries and radio when recharged.
7. It is advised to only charge batteries at room temperatures between 5 degrees C – 35 degrees C. In lower or higher temperatures full charge cannot be achieved.
8. Depending on the capacity of the batteries, charging from “empty” to “full” can take several hours, even up to 10 hours or more.
9. Do not charge batteries when the radio is hot or exposed to heat or heat sources.
10. It is advised to clean the metal contacts of the batteries and of the charger inside the radio e.g. with a contact-spray from time to time.
11. Do not use a mix of old and new rechargeable batteries.
12. Do not use a mix of rechargeable and non-rechargeable batteries.
13. Do not use a mix of full and empty rechargeable batteries.
14. Do not use batteries that have a different mAh capacity.

15. Do not use damaged, deformed or leaking batteries.
16. Battery level indication is an approximate indication only and can vary with battery type used.
17. Batteries can become hot during charging.
18. In cold conditions the capacity of batteries will be much lower than when used at normal room temperature
19. Batteries (even when supplied with the radio), as being consumables, do not fall under the warranty conditions of the radio.
20. It is advised to use Perfectpro rechargeable batteries as the radio and its charger were developed for use with these batteries.
21. Batteries should not be disposed of by incineration and with household waste.
22. Disposable batteries should be taken to a suitable recycling centre if possible.

Manual Tuning

1. Press the Power button to turn on the radio.
2. **Select the required frequency band by pressing the Band/Step button.**
3. Be sure to screw in the rubber FM antenna properly to get best reception. For AM band, rotate the radio to get best signal.
4. Rotate the Tuning Control knob will change the frequency in the following increments
FM: 50 or 100 kHz
AM: 9 or 10 kHz
5. Rotate the Volume Control knob to get required sound level.
6. To turn off the radio, press the Power button. Display will show OFF.

Memory presets stations

Storing stations in preset memories, please follow below steps.

There are 5 memory presets each for FM and AM radio.

1. Press the Power button to turn on the radio.
2. **Tune to required station as previously described.**
3. Press and hold down the required preset button until the radio beeps. The preset number **(e.g M1)** will appear in the display and the station will be stored under chosen preset button.

4. Repeat this procedure for the remaining presets.
5. Stations stored in preset memories can be over written by following above procedures.

Recall stations from preset memories

1. Press the Power button to turn on the radio.
2. Select the required frequency band by pressing the Band/Step button.
3. Momentarily press the required Preset button, the preset number and station frequency will appear in the display.

Display backlight

When radio is switched on, press any button except Power button will illuminate the LCD display for approx. 10 seconds.

Software version/Setting tuning step

Software version

The software display cannot be altered and is just for your reference.

1. When the radio is switched off, press and hold the Band/Step button 3 seconds until software version 'PXX' shown on the display.

Setting tuning step

Tuning step in some countries are different from where you purchase the radio. If you buy the radio in Europe and intend to use in Northern America or some Latin American countries, you may have to adjust tuning step so the radio may continue to serve you well.

1. After the software version is shown on the display, continue pressing and holding the Band/Step button until FM tuning step option appears and flashes on the display. Then rotate the Tuning control knob to select 50 kHz or 100 kHz for FM radio. Press the Band/Step button to confirm the selection. Now the AM tuning step option appears and flashes on the display
2. Rotate the Tuning control knob to select 9 kHz or 10 kHz for AM radio. Press the Band/Step button to confirm the setting. The tuning step setting is completed.

Note:

Adjusting the AM tuning step will erase your preset stations stored in the radio. The AM memory presets will revert to factory default.

Listening music via Bluetooth streaming

You need to pair your Bluetooth device with your BB-100 before you can auto-link to play/stream Bluetooth music through your BB-100. Pairing creates a 'bond' so two devices can recognize each other.

Pairing and playing your Bluetooth device for the first time

1. Press the Power button to turn on the radio. Press the Band/Step button to select Bluetooth(bt) function. The "bt" will show on the display. The Bluetooth status indicator on the radio will flash a fast blue to show the radio is discoverable.



2. Activate Bluetooth on your device according to the device's user manual to link to the radio. Locate the Bluetooth device list and select the device named "BB-100" (With some Smartphone's that are equipped with earlier versions than BT2.1 Bluetooth device, you may need to input the pass code "0000").

3. Once connected, there will be a confirmation tone sound. The Bluetooth status indicator will turn a solid blue. You can simply select and play any music from your source device. The volume control can be adjusted from your source device, or directly from the radio. To disconnect with your Bluetooth device, Press and hold the Bluetooth pairing button for 2 seconds. To reconnect to your Bluetooth device, press and release this button again.

4. Use the controls on your Bluetooth-enabled device or on the radio to play/pause and navigate tracks.

Note:

1) If 2 Bluetooth devices are pairing for the first time, both must search for your radio, it will show its availability on both devices. However, if one device links with this unit first, then the other Bluetooth device will not be found on the list.

2) If you take your source device out of range, the connection will be temporarily disconnected to your radio. Your radio will automatically reconnect if the source device is brought back in range. Be aware that during the period of disconnection, no other Bluetooth device can pair or link with your radio.

3) If "BB-100" shows in your Bluetooth device list but your device cannot connect with it, please delete the item from your list and pair the device with the radio again following the steps described previously.

4) The effective operation range between the system and the paired device is approximately 10 meters (30 feet). Any obstacle between the system and the device can reduce the operational range.

- 5) Bluetooth connectivity performance may vary depending on the connected Bluetooth devices. Please refer to the Bluetooth capabilities of your device before connecting to your radio. All features may not be supported on some paired Bluetooth devices.
- 6) With some mobile phones, making/receiving calls, text messages, e-mails or any other activities unrelated to audio streaming may mute the Bluetooth audio streaming or even temporarily disconnect from your device. Such behavior is a function of the connected device and does not indicate a fault with your **BB-100**.

Playing audio files in Bluetooth mode

When you have successfully connected your radio with the chosen Bluetooth device you can start to play your music using the controls on your connected Bluetooth device.

1. Once playing has started adjust the volume to the required setting using the Volume control on your radio or on your enabled Bluetooth device.
2. Use the controls on your device to play/pause and navigate tracks.

Alternatively, control the playback using Play/Pause ( (2) , Next track ( (3) ,

Previous track buttons ( (1)) on the radio.

3. Press and hold the Fast-forward or Rewind button to move through the current track. **Press and release the button again when the desired point is reached.**

Note:

Not all player applications or devices may respond to all of these controls.

Playing a previously-paired Bluetooth source device

The **BB-100** can memorize up to **2** paired Bluetooth source devices, when the memory exceeds this amount, the earliest pairing device will be over written from the device.

If your Bluetooth source device already paired with the **BB-100** previously, the unit will memorize your Bluetooth source device and will attempt to reconnect with a Bluetooth source device in the memory that was last connected. If the last connected Bluetooth source device is not available, the

BB-100 will try to connect to the second last Bluetooth source device.

Disconnecting your Bluetooth device

1. Press and hold the Bluetooth pairing button for 2 seconds on the radio to disconnect with your Bluetooth device or turn off Bluetooth function on your Bluetooth device to disable the connection. You will hear a beep and the Bluetooth status indicator on the radio will flash a fast blue to show the radio is discoverable again for pairing.
2. You can also press the Band/Step button to select any mode other than Bluetooth mode to disable the connection.

Reset the radio

If your radio fails to operate correctly or some digits on the display are missing or incomplete, please carry out the following procedure.

1. Make sure your radio is switched off.
2. Press and hold the Preset button 5 and Band/Step button at the same time for more than 2 seconds, the "dEF" symbol will appear and flash. Continue holding down these two buttons jointly until all the icons show on the display. All saved preset stations and Bluetooth memory will be cleared and the radio will revert to factory default settings.

Aux In socket

The Aux In socket is to connect audio source (like MP3 player or CD walkman) to listen the audio program via the speaker.

Remove the rubber cover, connect the audio source with a 3.5 mm audio connector wire, rotate the Volume Control knob to play the audio program.

Note:

You need to plug in 3.5 mm audio connector wire in order to change to the Aux in band.

Specifications

Frequency Coverage

FM: 87.50 – 108 MHz

AM: 520 – 1710 kHz (10 kHz)

522 - 1710 kHz (9 kHz)

AC Power

AC 120V/60Hz/10W

Batteries: 4 x C Size/UM-2/LR14 (recommend to use 4000mAh)

Output Power

2 Watt 10% T.H.D. @ 100 Hz @ DC battery 6V

4.5 Watt 10% T.H.D. @ 100 Hz @ AC 120V

Bluetooth

Bluetooth specification	Bluetooth® Ver 4.1
Profile Support	A2DP, AVRCP1.4
Bluetooth Audio CODEC	SBC
Transmitting Power	Power Class 2
Line of sight range	10 meters/30 feet

Sagean reserves the right to amend the specification without notice.



If at any time in the future you should need to dispose of this product please note that: Waste electrical products should not be disposed of with household waste. Please recycle where facilities exist. Check with your Local Authority or retailer for recycling advice. (Waste Electrical and Electronic Equipment Directive)