



AIRTRONICS[®]
Get The Advantage[™]



M1X OPERATING MANUAL

2.4GHz Digital High Response System

INTRODUCTION

We appreciate your purchase of the new Airtronics M11X FHSS 2.4GHz radio control system. This operating manual is intended to acquaint you with the many unique features of your state of the art M11X FHSS 2.4GHz radio control system. Please read this operating manual carefully so that you may obtain maximum success and enjoyment from the operation of your new M11X FHSS 2.4GHz radio control system.

The M11X FHSS 2.4GHz radio control system has been designed for the utmost in comfort and precise control of all types of model cars and boats. We wish you the best of success and fun with your new purchase.

SAFETY

- Be certain to read this operating manual in its entirety.
- 'Safety First' for yourself, for others, and for your equipment.
- Observe all the rules of the field, track, or lake where you operate your radio control equipment.
- If at any time during the operation of your model, should you feel or observe erratic operation or abnormality, end your operation as quickly and safely as possible. DO NOT operate your model again until you are certain the problem has been corrected. TAKE NO CHANCES.
- Your model can cause serious damage or injury, so please use caution and courtesy at all times.
- Do not expose the radio control system to water or excessive moisture.
- Please waterproof the receiver and servos by placing them in a water-tight radio box when operating R/C boat models.
- If you have little to no experience operating R/C models, we strongly recommend you seek the assistance of experienced modelers or your local hobby shop for guidance.
- The low voltage alarm will sound when the transmitter battery voltage drops to ~6.7 volts. If this occurs, stop using the transmitter as soon as possible, then recharge the transmitter battery.

This radio control system operates on the 2.4GHz frequency band. The 2.4GHz connection is determined by the transmitter and receiver pair, therefore, unlike ordinary crystal systems, your model can be used without frequency control.

Additional 2.4GHz receivers can be purchased and paired with the included 2.4GHz transmitter through the pairing operation. Please note that due to differences in the implementation of 2.4GHz technology among different manufacturers, only Airtronics brand 2.4GHz FHSS receivers are compatible with your radio control system. Please see your Airtronics dealer for more information.

FCC COMPLIANCE STATEMENT

This equipment has been tested and found to comply with the limits for a Class B digital device, pursuant to Part 15 of the FCC Rules. These limits are designed to provide reasonable protection against harmful interference in a residential installation. This equipment generates, uses, and can radiate radio frequency energy and, if not installed and used in accordance with the instructions, may cause harmful interference to radio communications. However, there is no guarantee that interference will not occur in a particular installation.

If this equipment does cause harmful interference to radio or television reception, which can be determined by turning the equipment off and on, the user is encouraged to try to correct the interference by one or more of the following measures:

- Reorient or relocate the receiving antenna.
- Increase the separation between the equipment and the receiver.
- Connect the equipment into an outlet on a circuit different from that to which the receiver is connected.
- Consult the dealer or an experienced technician for help.

This device complies with Part 15 of the FCC Rules and with RSS-210 of Industry Canada. Operation is subject to the following two conditions:

- 1) This device may not cause harmful interference, and
- 2) This device must accept any interference received, including interference that may cause undesired operation.

WARNING: Changes or modifications made to this equipment not expressly approved by Airtronics may void the FCC authorization to operate this equipment.

RF Exposure Statement

This transmitter has been tested and meets the FCC RF exposure guidelines when used with the Airtronics accessories supplied or designated for this product, and provided at least 20 cm separation between the antenna the user's body is maintained. Use of other accessories may not ensure compliance with FCC RF exposure guidelines.

FEATURES AND SPECIFICATIONS

SYSTEM FEATURES

- 2.4GHz FHSS Transmitter and Receiver
- Large LCD Display
- Left or Right Hand Grip
- Digital Trim
- Key-Lock
- Display Switch
- Adjustable Handle
- Adjustable Steering Wheel Tension
- 3 Page Programming
- Timer Vibration
- Battery Monitor
- User Naming
- Assignable Digital Trims
- Assignable Switches
- Audio Sound Levels
- White or Blue Back Light Display
- Servo Monitor
- Tweak
- 2 C-Mixes
- Brake Mixing
- Throttle Hold
- Starting Position
- Servo Reversing
- Lap, Interval and Down Timers
- Sub Trim
- 30 Model Memory
- Model Copy
- Model Naming
- Model Select
- Traction Control
- Anti Lock Braking
- Servo Speed
- ARC Steering and Throttle
- Expo Steering and Throttle
- End Point Adjustment
- Dual Rate Steering
- Selectable Monitor Display
- Rubber Stands
- LCD Cover
- 1 Dial Knob
- Grip Switch
- 2 or 4 Channel Selectable

SYSTEM SPECIFICATIONS

Transmitter

Model:
Output Power:
Output Voltage: 6.5v - 9.0v
Power Supply:
Weight:
Frequency:

Receiver

Model:
Frequency:
Power Supply:
Weight:
Dimensions:
Fail Safe Limit:

Optional Items

Recommended Servos (Available From Your Local Airtronics Dealer)

Airtronics 94771M ERG-WZ Digital High-Speed Metal Gear Ball Bearing Servo



Torque: 82oz/in (5.9kg/cm @ 4.8v)
103oz/in (7.4kg/cm @ 6.0v)

Speed: 0.13 sec/60° @ 4.8v
0.10 sec/60° @ 6.0v

Dimensions: 1.54 x 0.79 x 1.47in (39.1 x 20.1 x 37.3mm)

Weight: 1.98oz (56gr)

Airtronics 94772M ERG-WG Digital High-Speed Precision Metal Gear Ball Bearing Servo



Torque: 67oz/in (4.8kg/cm @ 4.8v)
83oz/in (6.0kg/cm @ 6.0v)

Speed: 0.11 sec/60° @ 4.8v
0.09 sec/60° @ 6.0v

Dimensions: 1.54 x 0.79 x 1.47in (39.1 x 20.1 x 37.3mm)

Weight: 1.98oz (56gr)

Airtronics 94773M ERG-WX Digital High-Torque Metal Gear Ball Bearing Servo



Torque: 156oz/in (11.2kg/cm @ 4.8v)
194oz/in (14.0kg/cm @ 6.0v)

Speed: 0.15 sec/60° @ 4.8v
0.12 sec/60° @ 6.0v

Dimensions: 1.54 x 0.79 x 1.47in (39.1 x 20.1 x 37.3mm)

Weight: 2.01oz (57gr)



Both analog and digital servos will work with your M11X FHSS 2.4GHz radio control system, however, to get the most out of your experience, we recommend the use of digital servos.

DRIVING POSITION ADJUSTMENTS

Every effort has been made to provide optimum transmitter weight and balance on your M11X FHSS 2.4GHz radio control system. The wheel and trigger are placed on the same axis, permitting you to focus on steering and throttle control. The driving position and steering/throttle tension are adjustable to maximize driving precision.

STEERING WHEEL TENSION

The steering wheel spring tension can be adjusted using a 1.5 mm hex wrench as shown at right. To increase steering wheel spring tension tighten the hex screw (turn clockwise). To decrease steering wheel spring tension loosen the hex screw (turn counter-clockwise).

! The spring tension is factory set at the lowest (softest) position.

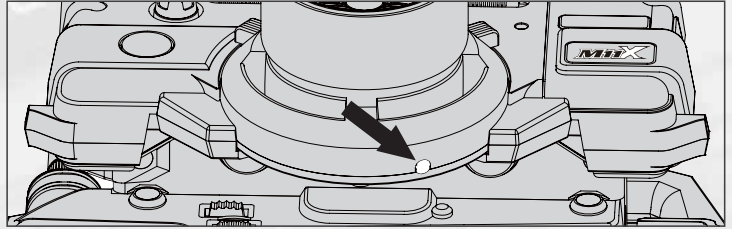

DRIVING POSITION

The driving position height can be adjusted to change the balance (feel) of the transmitter in your hand.

! The transmitter ships with the grip bracket in the lower height position.

- 1) Remove the M4 socket-head cap screws on each side of the transmitter using a 3mm hex wrench.
- 2) Detach the grip downward from the upper transmitter unit. Be careful to avoid damaging the lead wires that are connected on both units.
- 3) There are four phillips head screws holding each side of the grip bracket. Remove the screws and reset the bracket screw hole at the lower screw hole. This sets the bracket to the higher height position.
- 4) After resetting the driving position, retighten the grip bracket screws, then align the upper transmitter unit and reinstall it using the two M4 socket-head cap screws.

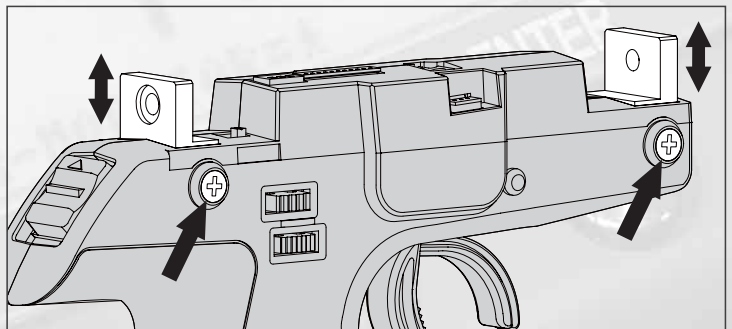
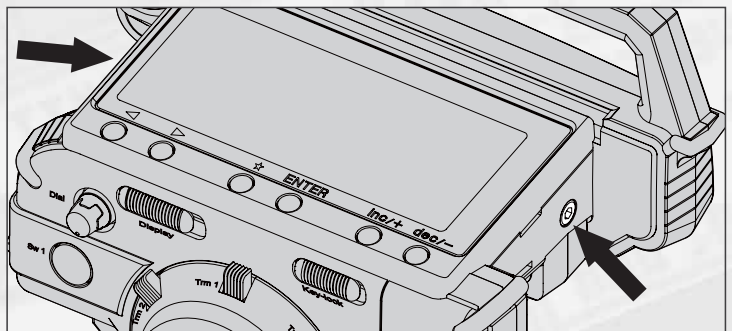

THROTTLE TRIGGER TENSION

The throttle trigger spring tension can be adjusted to suit your taste.

! The spring tension is factory set at the lowest (softest) position.

- 1) Remove the M4 socket-head cap screws on each side of the transmitter using a 3mm hex wrench.
- 2) Detach the grip downward from the upper transmitter unit. Be careful to avoid damaging the lead wires that are connected on both units.
- 3) Adjust the throttle trigger spring tension using a 1.5 mm hex wrench as shown at right. To increase throttle trigger spring tension tighten the hex screw (turn clockwise). To decrease throttle trigger spring tension loosen the hex screw (turn counter-clockwise).
- 4) After resetting the throttle trigger spring tension, align the upper transmitter unit and reinstall it using the two M4 socket-head cap screws.

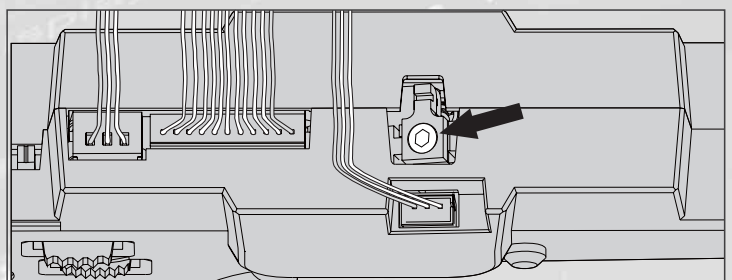
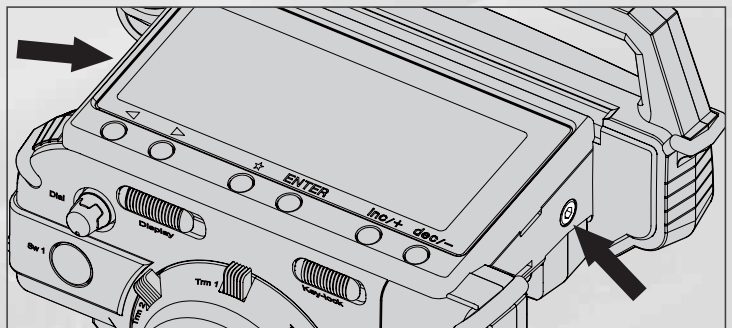

DRIVING POSITION ADJUSTMENTS

TRIM RING POSITION

The position of the digital trim ring can be repositioned to better suit your taste. Five different positions are available.



Trm 1 is factory set at the top center position.

- 1) Remove the M4 socket-head cap screws on each side of the transmitter using a 3mm hex wrench.
- 2) Detach the grip downward from the upper transmitter unit. Be careful to avoid damaging the lead wires that are connected on both units.
- 3) Remove the three M2.6 socket-head cap screws from the backside of the trim ring (i.e. behind the steering wheel as shown on the photo) using a 2mm hex wrench.
- 4) Rotate the trim ring to the desired position. The trim ring can be positioned in one of five different positions. Set the trim ring at the desired position, then retighten the three M2.6 socket-head cap screws.
- 5) After resetting the trimmer position, attach the upper transmitter unit back into place. Tighten using a 3mm hex wrench and two (2) 4mm hex socket head cap screws per side.

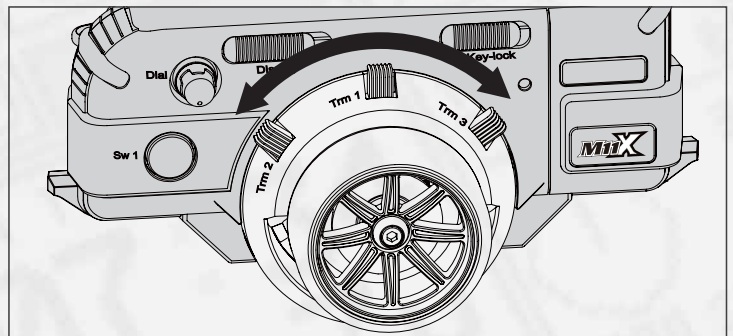
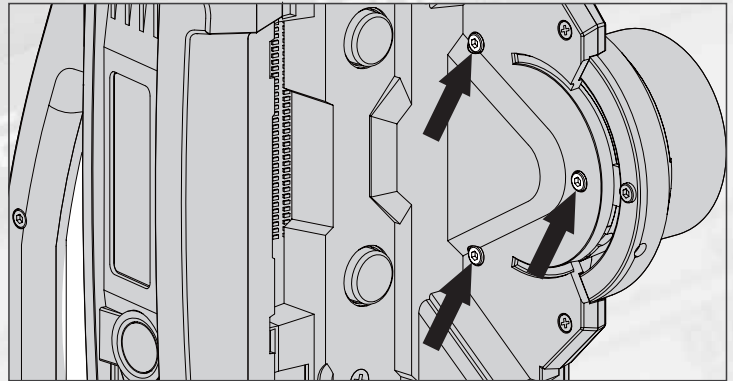

STEERING WHEEL POSITION

The steering wheel position can be changed from the right side to the left side to accommodate left-handed users.



The transmitter ships with the steering wheel on the right side of the transmitter for right-handed users.

- 1) Remove the M4 socket-head cap screws on each side of the transmitter using a 3mm hex wrench.
- 2) Detach the grip downward from the upper transmitter unit. Be careful to avoid damaging the lead wires that are connected on both units.
- 3) Set the Left/Right selector switch to 'L' located above Trm 4 and Trm 5.
- 4) Rotate the grip by 180 degrees.
- 5) After rotating the grip, align the upper transmitter unit and reinstall it using the two M4 socket-head cap screws.

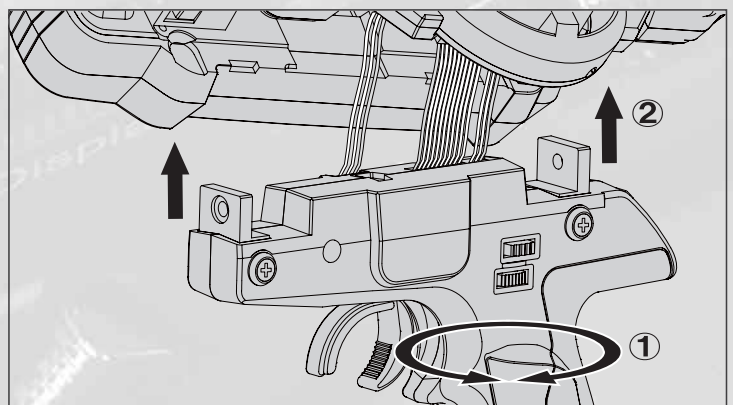
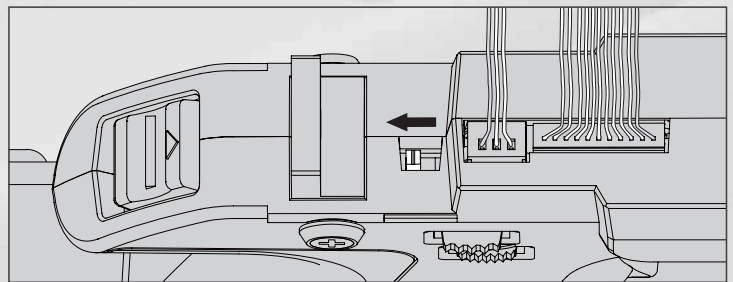
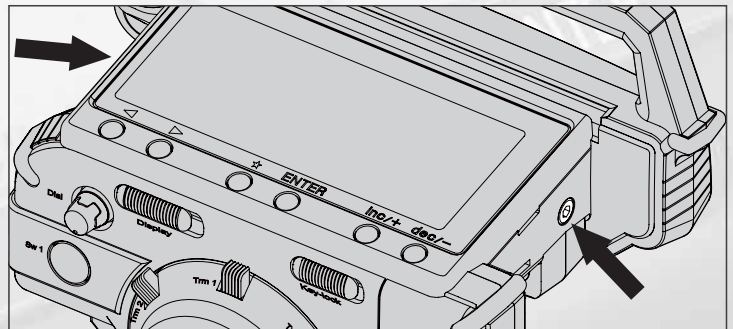

FEATURES AND CONTROLS

Use the diagrams below and on the next page to familiarize yourself with the different features and controls of your new M11X FHSS 2.4GHz radio control system transmitter and RX-451 receiver.

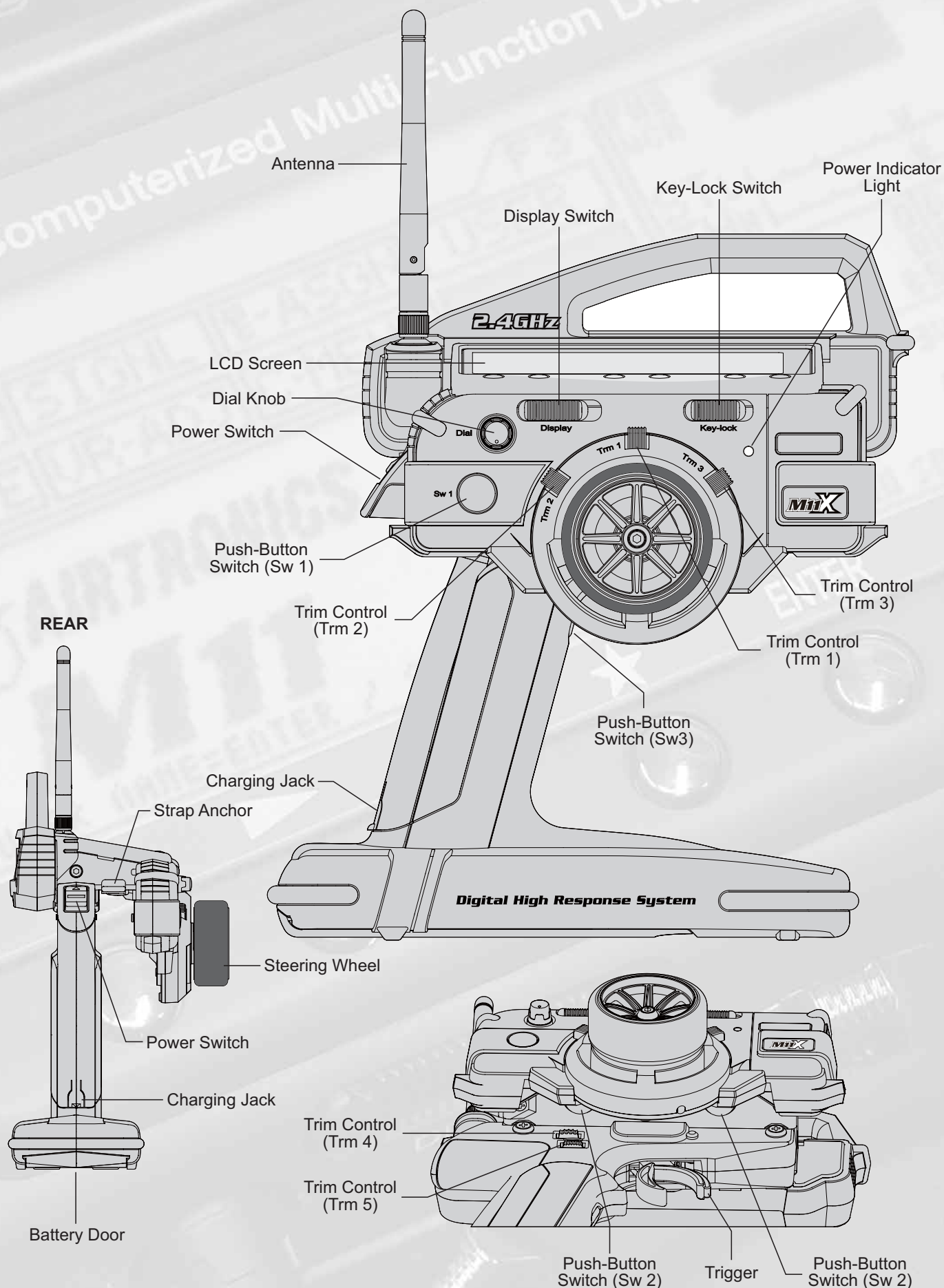

FEATURES AND CONTROLS

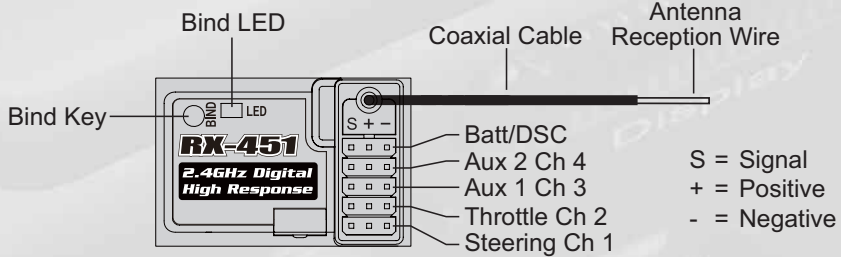
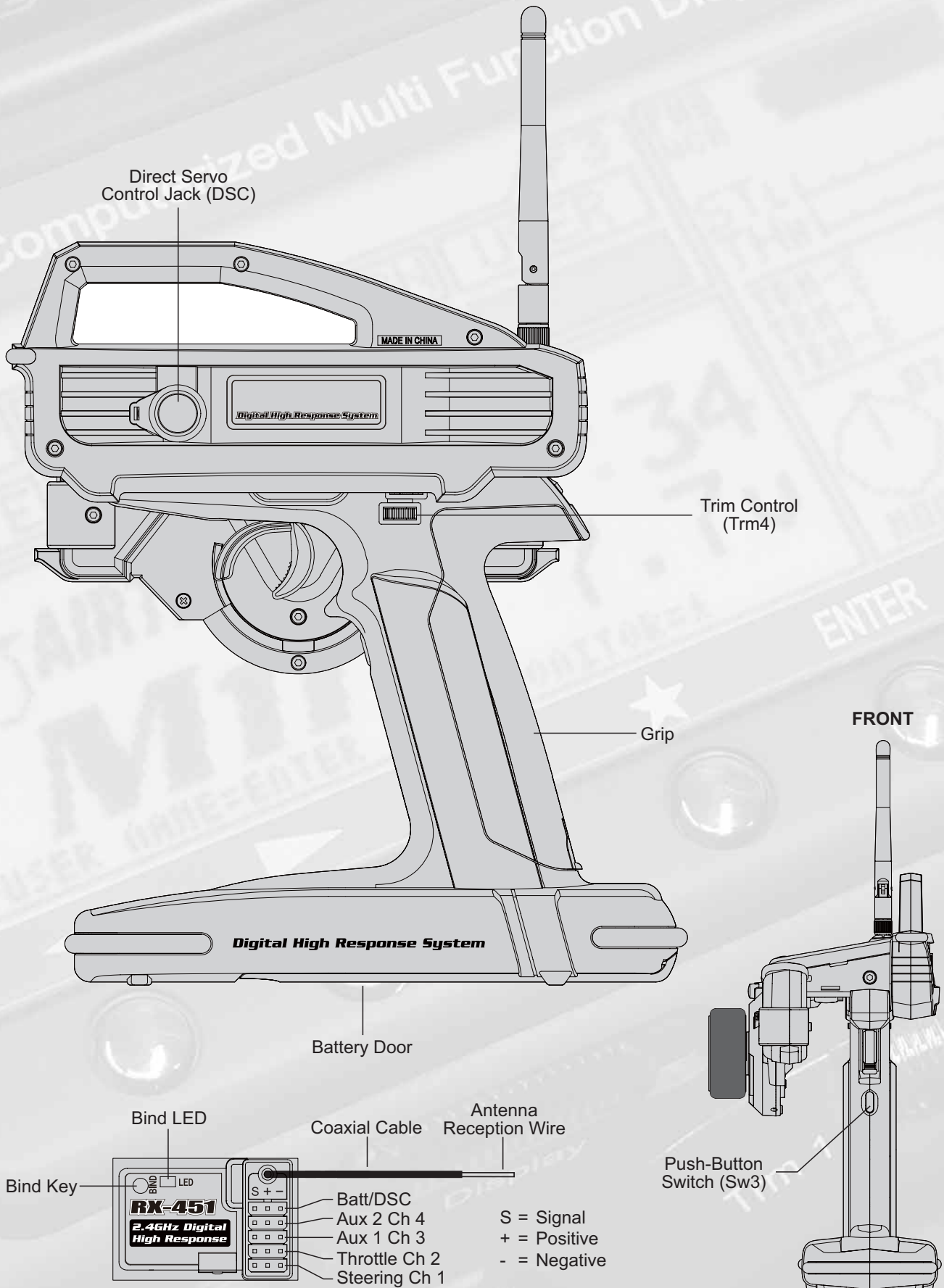

For more information about the terms used to describe the M11X FHSS 2.4GHz radio control system features, please refer to the glossary in the back of this operating manual.

USAGE PRECAUTIONS

Please observe the following receiver precautions when installing and using your new Airtronics M11X FHSS 2.4GHz radio control system.

2.4GHZ FREQUENCY BAND PRECAUTIONS

- The 2.4GHz frequency band may be used by other devices, or other devices in the immediate area may cause interference on the same frequency band. Always before use, conduct a bench test to ensure that the servos operate properly. Also, conduct checks with the transmitter as distant as possible from your model.
- The response speed of the receiver can be affected if used where multiple 2.4GHz radio controllers are being use, therefore, carefully check the area before use. Also, if response seems slow during use, stop your model immediately and stop use.
- If the 2.4GHz frequency band is saturated (too many radio controllers on at once), as a safety precaution, the radio control system may not bind. This ensures that your radio control system does not get hit by interference. Once the frequencies have been cleared, or the saturation level has dropped, your radio control system should be able to bind without any problems.

TRANSMITTER PRECAUTIONS

- Turn the transmitter ON first and then turn ON the receiver. After using your model, turn the receiver OFF first, then turn the transmitter OFF. It can be dangerous if you activate the components in reverse order as the servos may start up inadvertently.
- Before use, double-check that the transmitter and receiver batteries are sufficiently charged.
- Never touch the transmitter antenna during use. Doing so may cause loss of transmitter output, making it impossible to control your model.
- The transmitter's antenna is delicate. Handle it with care.
- Before use, the transmitter antenna should be moved in the fully upright position. After use, to prevent the chance of damaging the antenna, the antenna should be moved into the horizontal stowed position.
- Do not press the Bind Key during use. The radio signal is interrupted while the Bind key is pressed. It may also require a short time to restore the signal after releasing the Bind key, which can be dangerous.

RECEIVER PRECAUTIONS

- The receiver antenna consists of a coaxial cable and a reception wire (the thin tip at the end of the coaxial cable). When you mount the receiver antenna, do not bend the reception wire. Reception performance decreases if the reception wire is bent.
- The antenna wire is delicate, therefore, handle with care. Do not pull on the antenna wire with force. Do not cut or extend the antenna wire.
- The coaxial cable (the thicker portion or the antenna) can be bend into gentle curves, however, do not bend the coaxial cable accutely, or repeatedly bend it, or the antenna core can be damaged.
- The antenna wire should be installed into a vertical plastic tube per your particular model's assembly instructions. Keep the receiver antenna away from motors, battery, and ESC.
- There is a danger of runaway operation if connectors shake loose during use. Make sure that the receiver, servo(s), and switch connectors are securely fitted.
- The receiver is susceptible to vibration, shock, and moisture. Take appropriate measures to protect against vibration and moisture. Failure to take appropriate measures could result in runaway operation or damage to the receiver.
- When installing the receiver, avoid contact with any carbon or metal chassis components.
- Contact between metal parts mounted on a model can result in electrical noise, which can adversely effect receiver performance and possibly result in runaway operation or damage to your model.
- With electric-powered models, be sure to fit the motor with a noise suppression capacitor. Without a noise suppression capacitor, excessive electrical noise generation can cause runaway operation and/or result in damage to your model.
- Use rubber anti-vibration absorbers with servos. Direct transmission of engine vibration to servos can cause servo failure and possibly result in runaway operation with damag to your model vehicle.
- The manufacturer disclaims all responsibility for damages resulting from use of components other than genuine Airtronics components.

LCD MENU KEYS

The Airtronics M11X FHSS 2.4GHz radio control system features 6 keys for menu operation. This section summarizes the functions of each of the 6 menu keys in addition to describing the main display areas of the LCD screen when the transmitter is turned on.

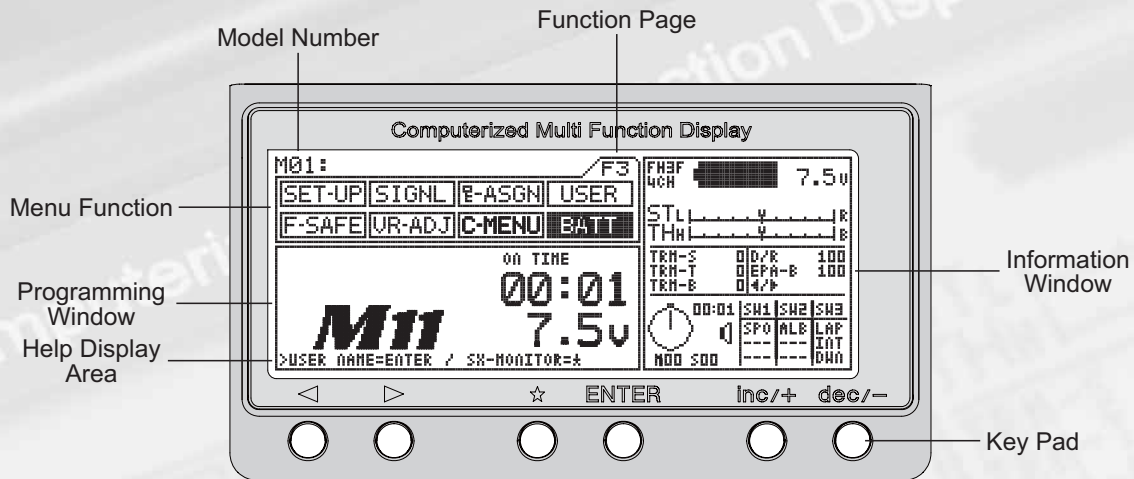

! A plastic cover is included that snaps over the LCD screen and key pad to protect it during travel or storage.

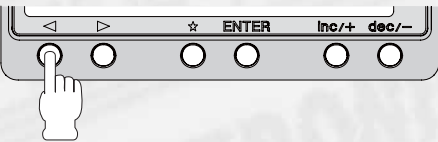
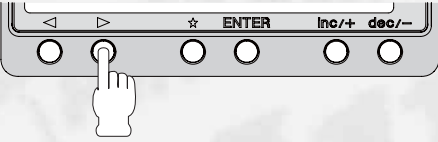
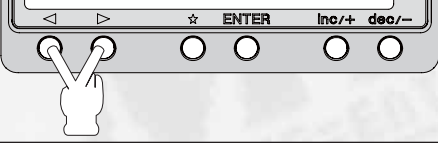
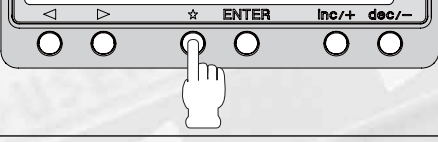
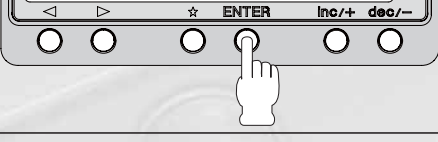
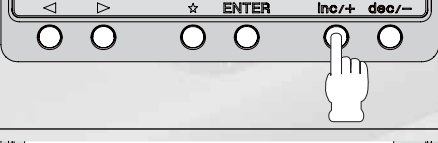
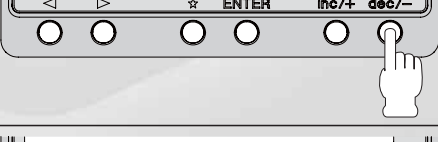
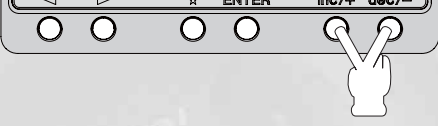
KEY	NAME	FUNCTION
	Function Select Key - Left	Moves the Menu Function cursor left (backward) to the previous menu function.
	Function Select Key - Right	Moves the Menu Function cursor right (forward) to the next menu function.
	Function Page Select Key Sequence	Pressing both keys will scroll through the Function Pages in order - F1, F2, and F3. The Menu Function The Cursor will highlight the first function on that page.
	★ Scroll Key	Moves the Menu Key backward in the Programming Area. Also used in the Help Display Area.
	Enter Key	Moves the Menu Key forward in the Programming Area. Also used in the Help Display Area.
	INC/+ Key (Increase)	Increases number values in the Programming Area. Also scrolls up the Selection List.
	DEC/- Key (Decrease)	Decreases number values in the Programming Area. Also scrolls down the Selection List.
	INC/+ and DEC/- (Reset)	Pressing both keys will Reset the selection to the Factory Default Setting.

FUNCTION PAGES

The functions of the M11X FHSS 2.4GHz radio control system span three pages, F1 to F3. Pressing the < and > function keys at the same time displays each of the three function pages in succession - F1, F2, F3...F1, etc. Pressing either the < or > function keys separately scrolls through the individual functions assigned to the function page you're currently viewing.

 When you press either of the 6 menu keys, the LCD back-lighting will automatically turn on. If no menu key is pressed, the LCD back-lighting will turn off after approximately 10 seconds to conserve battery power.

All of the functions listed below are detailed in their own separate sections throughout this operating manual.

Function Menu F1 consists of the following individual functions:

- Dual Rate
- End Point Adjustment
- Exponential
- Adjustable Rate Control
- Steering Speed
- Anti-Lock Braking
- Traction Control
- Model

Menu Function
Programming Area
Help Display Area

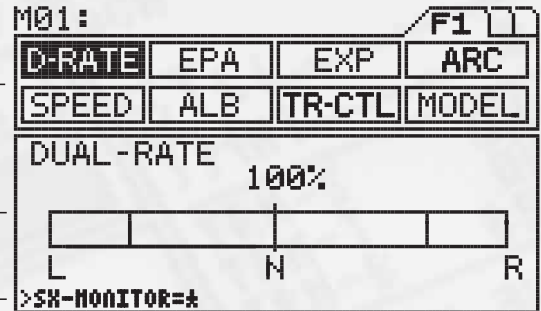

Function Menu F2 consists of the following individual functions:

- Sub-Trim
- Timer
- Servo Reversing
- Start Position
- Throttle Hold
- Brake Mixing
- Compensation Mixing
- Servo Monitor



Function Menu F3 consists of the following individual functions:

- Transmitter Setup
- Audio Signal Sound
- Switch/Trim Assignment
- User Name
- Fail-Safe Setup
- VR-Adjustment Menu
- Customer Menu
- Battery Display Menu

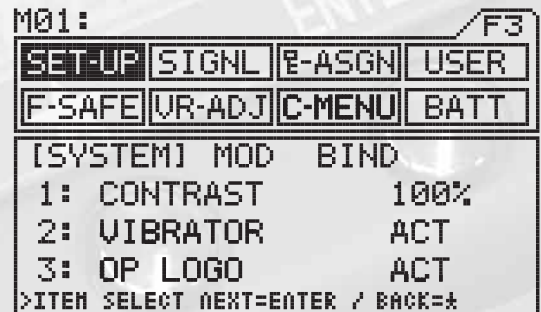

The constant display area described below is provided on the right side of the screen. This makes it possible to determine, at a glance, the current setting status of various functions from any menu screen.

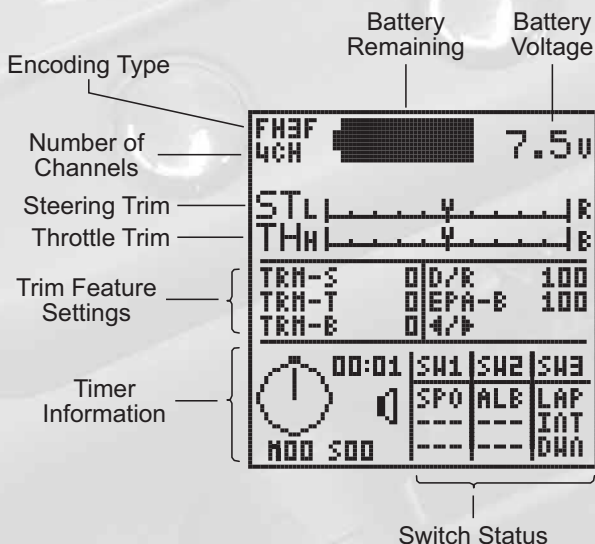

Pressing the ★ key quickly switches between the information screen and the servo monitor screen.



Dual Rate, Brake EPA, and 3CH Settings

BATTERY AND OPERATING TIMER

SET-UP	SIGNL	E-ASGN	USER
F-SAFE	UR-ADJ	C-MENU	BATT

Function Page 3 (BATT)

TRANSMITTER BATTERY VOLTAGE

The transmitter battery voltage is displayed on two different areas of the LCD screen. Transmitter battery voltage is displayed in the information window and in the battery menu window. Transmitter battery voltage is displayed in decimal value in increments of 0.1 volts.

Programming Window

Logo Screen

Battery Voltage*

Information Window

Battery Voltage

*Will start blinking if battery voltage reaches 6.7 volts.

When the transmitter battery voltage drops to 6.7 volts, the transmitter will start beeping and vibrating (if the vibration feature is enabled), and will continue every 30 seconds. When this happens, promptly stop operation and charge or replace the transmitter batteries. Continuing to use the transmitter after the low voltage alarm sounds can result in loss of control of your model.

User Screen

In the BATT menu you can press the ENTER key to switch between the Logo screen and the User screen.

OPERATING TIMER

The operating timer is a count-up timer that records the time the transmitter has been turned on in hours and minutes. This timer can be reset to 00:00 by pressing both the (INC/+) (DEC/-) keys at the same time. Resetting the operating timer after you have charged or replaced the transmitter battery will give you the amount of time the current battery has been in use.

Operation Timer

Operation Timer

Computerized Multi Function Display



AIRTRONICS[®]
Get The Advantage[™]

Airtronics is Distributed Exclusively in North America by:

Global Hobby Distributors
18480 Bandilier Circle
Fountain Valley, CA 92708

Telephone: (714) 963-0329
Fax: (714) 962-6452
Email: service@globalhobby.net

<http://www.airtronics.net>