

## SYSTEM MENU OVERVIEW

SYSTEM

To access the various SYSTEM Programming Menus, turn the transmitter ON, then press the SELECT switch to highlight the SYSTEM menu. Press the ENTER key to open the SYSTEM menu.

Scroll UP or DOWN to highlight the desired Programming Menu, then press the ENTER key to open that menu.

⚠ Depending on the Car Type chosen, some Function Programming Value Names may differ from those shown in this section.

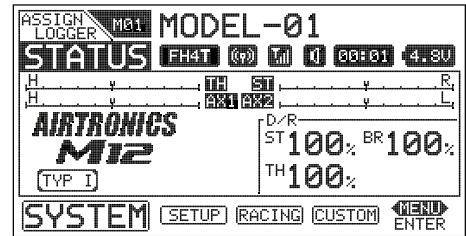

The following Programming Menus are available within the SYSTEM menu:

MENU	MENU DESCRIPTION	PAGE #
TYPE	Choose Car Type Templates From Normal to Crawler	PG. 24
MODEL	Model Select, Model Name, Model Copy, Model Clear and Model Sort	PG. 25
DMS	Direct Model Select - Use to Quickly Select Your Favorite Models	PG. 29
BIND	Bind, Choose Modulation Type, Safety Link Number and Servo Operating Mode	PG. 30
SERVO	Use the Servo Monitor to View Servo Travel Digitally	PG. 32
ASSIGN	Assign Functions to the Switches, Rotary Dial and Auxiliary Lever	PG. 33
BUZZER	Turn Audible Key Tones and Alarms ON and OFF and Control Their Pitch and Volume	PG. 38
VIBRATOR	Turn Vibrating Alerts and Alarms ON and OFF	PG. 39
LCD	Adjust the Contrast, Brightness and Display Mode of the LCD Screen	PG. 40
AUX TYPE	Choose the Operating Mode of the Two Auxiliary Channels	PG. 41
TRIM TYPE	Choose the Desired Servo Trim Type - Either Parallel or Centered	PG. 43
TH TYPE	Choose the Desired Throttle Bias Type	PG. 43
VR ADJUST	Calibrate Steering, Throttle and Auxiliary Lever Controls	PG. 44
BATT	Specify Transmitter Battery Low Voltage Alert and Limit Alarms	PG. 46
LOG SETUP	Program TELEMETRY Screen and Telemetry Recording Options	PG. 48
BOOT MENU	Change Transmitter Start-Up Behavior	PG. 56
USER NAME	Change the Name Displayed Above the M12S Logo on the STATUS Screen	PG. 56
PC-LINK	Save Telemetry Logs, Save and Load Model Programming and Update Firmware	PG. 58
INFORMATION	View Transmitter Firmware Version and On-Time Information	PG. 61

## TYPE MENU (CAR TYPE TEMPLATES)

SYSTEM

The Type function allows you to quickly set up the transmitter's Mixing options based on the type of Model you're driving. Common templates for Car or Truck and Crawler Car Types are provided. For example, if your Crawler features separate Front and Rear Steering servos, choosing one of the Crawler Car Types will automatically program the transmitter for Four Wheel Steering.

The TYPE menu will also display what receiver channels to plug the servos into since this will vary depending on the Car Type chosen. This takes the guess-work out of setting up your Model.

**WARNING:** TYPE menu selections are designed to be used when setting up a new Model and should be done prior to making any programming changes to your Model. When the Type function is used to change the Car Type, all Programming Data (including custom Programming Data) for the current Model will be RESET!

### Choosing a Car Type:

- 1) From within the SYSTEM menu, scroll UP or DOWN to highlight the TYPE menu.

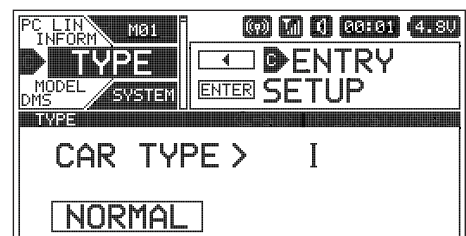

## TYPE MENU (CAR TYPE TEMPLATES)

SYSTEM

### Choosing a Car Type, Continued:

- Press the ENTER key to open the TYPE menu. The cursor will default to CAR TYPE > I.
- Press the ENTER key, then scroll UP or DOWN to Select the desired Car Type as shown in the table below. The TYPE Menu Programming Display shows the Car Type (Normal or Crawler) and which servos should be plugged into what receiver channel slots. For example, CAR TYPE > VII is a Normal Car Type that might be used for a 1:5 scale off-road gas buggy that uses two Steering servos and a separate second Brake servo. In this example, the Left Steering servo should be plugged into channel 3, the Throttle/first Brake servo should be plugged into channel 2 and the second Brake servo should be plugged into channel 4.
- Press the ENTER key. MODEL DATA CLEAR? NO/YES will be displayed.
- Scroll UP or DOWN to highlight YES, then press the ENTER key. EXECUTING will be displayed and the current Model Programming Data will be reset with the Selected Car Type options.

⚠ If you want to go back and change the Car Type or you don't want to create the new Car Type for any reason, choose NO or press the BACK key prior to EXECUTING.

⚠ Your particular Model may not require the use of all four channels, even though each Car Type template may show them. In this case, those channels will simply go unused.

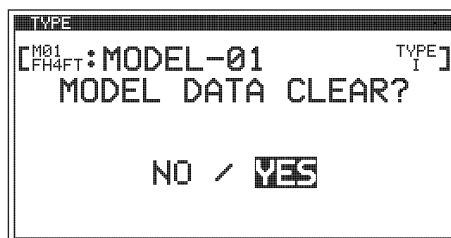
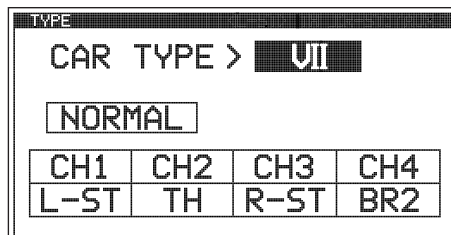
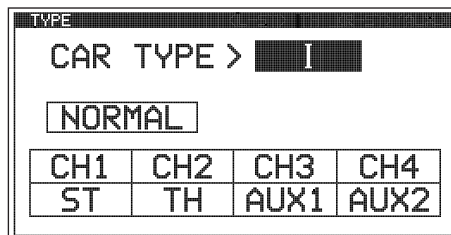

TYPE CH	TYP I	TYP II	TYP III	TYP IV	TYP V	TYP VI	TYP VII	TYP VIII	TYP IX	TYP X
CH 1	ST	ST	ST	ST	L-ST	L-ST	L-ST	F/ST	ST	F/ST
CH 2	TH+BR	TH	TH+BR	TH	TH+BR	TH	TH+BR	TH+BR	F/TH+BR	F/TH+BR
CH 3	AUX1	BR	BR2	BR	R-ST	R-ST	R-ST	R/ST	R/TH+BR	R/ST
CH 4	AUX2	AUX	AUX	BR2	AUX	BR	BR2	AUX	AUX	R/TH+BR

ST=Steering • TH=Throttle • BR=Brake • BR2=Brake 2 • R-ST=Right • L-ST=Left • R/ST or R/TH=Rear • F/ST or F/TH=Front

## MODEL MENU (SELECT, NAME, COPY, CLEAR AND SORT)

SYSTEM

The MODEL menu allows you to Select different Models, Name your saved Models, Copy Programming Data from one Model to another Model, Clear Programming Data from one or more Models and Sort your saved Models into a Custom list, using the Model Select, Model Name, Model Copy, Model Clear and Model Sort functions. This allows you to use the transmitter with different Models and quickly and easily Select the Programming Data for each of them. Programming Data for up to 50 different Models can be stored in the transmitter's memory.

### Model Select

The Model Select function allows you to load the Programming Data for the particular Model you wish to drive. The MODEL SELECT menu displays the currently Selected Model, along with a list of available Models that can be Selected. The current Modulation Type and Car Type of each Model is also displayed. The transmitter can store Programming Data for up to 50 different Models.

### Selecting a Model:

- From within the SYSTEM menu, scroll UP or DOWN to highlight the MODEL menu.

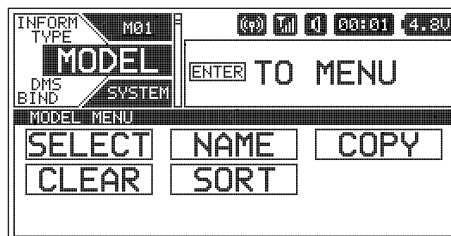

## MODEL MENU (SELECT, NAME, COPY, CLEAR AND SORT)

SYSTEM

### Selecting a Model, Continued:

2) Press the ENTER key to open the MODEL menu. The SELECT menu will be highlighted and the currently Selected Model will be displayed in brackets at the top of the Model Select List.

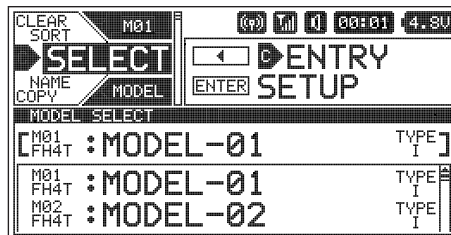

3) Press the ENTER key to open the SELECT menu, then scroll UP or DOWN within the Model Select List to highlight the Model you would like to load Programming Data for.

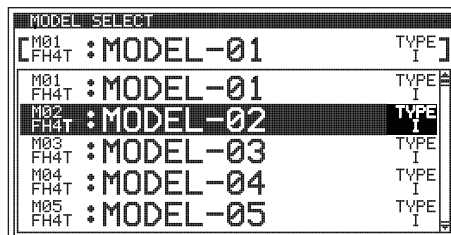

4) Press the ENTER key. MODEL SELECT OK? NO/YES will be displayed. Scroll UP or DOWN to highlight YES, then press the ENTER key.

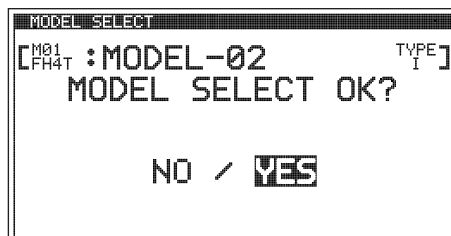

 If you want to go back and change Models or you don't want to Select a different Model for any reason, choose NO or press the BACK key prior to EXECUTING.

5) EXECUTED will be displayed and the Model that you just Selected will be displayed in brackets above the Model Select List.

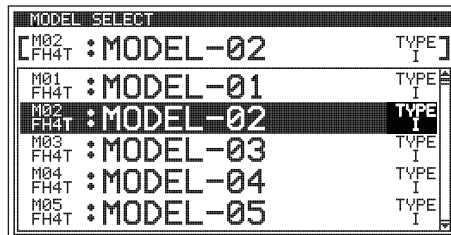

 When a Model is Selected, the Programming Data for that Model will be loaded immediately.

### Model Name

The Model Name function allows you to name each of the 50 individual Models. This makes it easy to keep track of multiple Models. The Model Name can consist of up to 14 letters, numbers or symbols. Choose from capital letters, Lower case letters, numbers and various symbols. A Model must be Selected before a Model Name can be entered or modified. In the default configuration, M01:MODEL-1 is Selected. To enter a Model Name for another Model, that Model must first be Selected using the Model Select function.

### Entering a Model Name:

1) From within the SYSTEM menu, scroll UP or DOWN to highlight the MODEL menu.

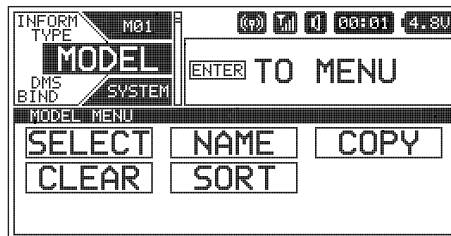

2) Press the ENTER key to open the MODEL menu, then scroll UP or DOWN to highlight the NAME menu.

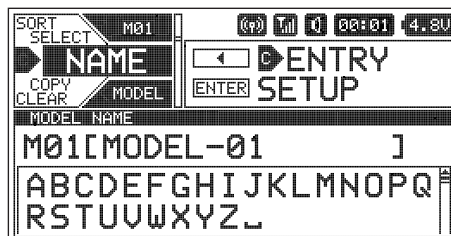

## MODEL MENU (SELECT, NAME, COPY, CLEAR AND SORT)

SYSTEM

### Entering a Model Name, Continued...

- Press the ENTER key to open the NAME menu. The underscore will be positioned under the first character in the Model Name.
- Press the SELECT switch RIGHT or LEFT or scroll UP or DOWN to move the underscore under the character you want to change, then press the ENTER key.
- Scroll UP or DOWN and press the SELECT switch RIGHT or LEFT to highlight a character in the Character List. Press the ENTER key to Select the highlighted character. That character will be displayed in the Model Name and the underscore will advance to the next space.
- Repeat step 5 to enter the rest of the characters. Up to 14 characters can be entered. If desired, press the BACK key to re-gain control of the underscore, then use the SELECT switch or scroll UP or DOWN to move the underscore RIGHT or LEFT. To add a space (or spaces) in your Model Name, use the  character.

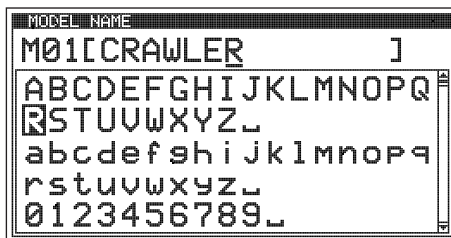
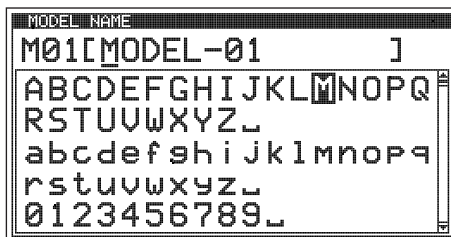



### Deleting a Character:

- Press the SELECT switch RIGHT or LEFT or scroll UP or DOWN to move the underscore under the character in your Model Name you want to delete.
- Press the ENTER key, then scroll UP or DOWN and press the SELECT switch RIGHT or LEFT to highlight the  character in the Character List. Press the ENTER key. The character in your Model Name will be deleted and the underscore will advance to the next space.

 If you can't move the underscore, press the BACK key to re-gain control of the underscore.

### Deleting a Model Name:

- Press the SELECT switch RIGHT or LEFT or scroll UP or DOWN to move the underscore under the first character in your Model Name.
- Press the ENTER key, then scroll UP or DOWN and press the SELECT switch RIGHT or LEFT to highlight the  character in the Character List. Continuously press the ENTER key to delete each character in your Model Name.

 If you can't move the underscore, press the BACK key to re-gain control of the underscore.

### Model Copy

The Model Copy function allows you to copy the Programming Data FROM the currently Selected Model TO another Model. For example, if you have two Models that are similar, you can copy the Programming Data from the first Model to the second Model to use as a base to start fine-tuning the programming for the second Model. Make sure that prior to using the Model Copy function, you first Select and load the desired Model you want to copy Programming Data FROM, using the Model Select function.

### Copying Model Programming Data:

- From within the SYSTEM menu, scroll UP or DOWN to highlight the MODEL menu.

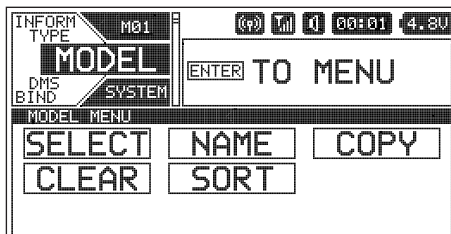

- Press the ENTER key to open the MODEL menu, then scroll UP or DOWN to highlight the COPY menu.

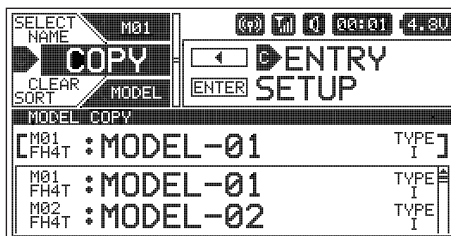

## MODEL MENU (SELECT, NAME, COPY, CLEAR AND SORT)

SYSTEM

### Copying Model Programming Data, Continued...

- Press the ENTER key to open the COPY menu. The currently Selected Model will be displayed in brackets above the Model Copy List.
- Scroll UP or DOWN within the Model Copy List to highlight the Model you would like to copy the current Model's Programming Data TO.
- Press the ENTER key. MODEL COPY OK? NO/YES will be displayed. Scroll UP or DOWN to highlight YES, then press the ENTER key.

 All Model-specific Programming Data, including the Model Name will be copied to the highlighted Model. If you want to go back and change Models or you don't want to Copy the Programming Data for any reason, choose NO or press the BACK key prior to EXECUTING.

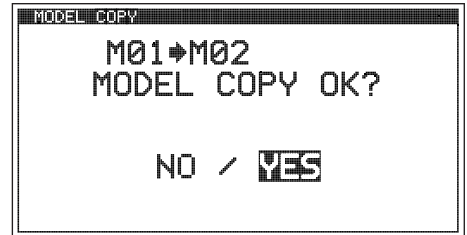
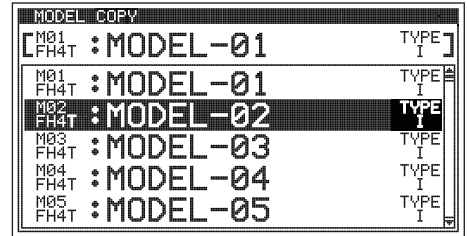

- EXECUTED will be displayed and the Model you just copied Programming Data TO will be highlighted in brackets and the top of the Model Copy List.

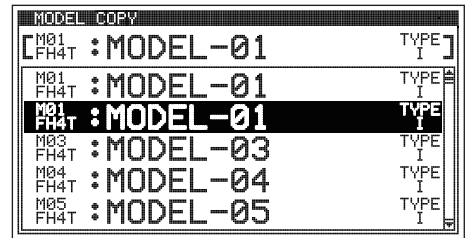

### Model Clear

The Model Clear function allows you to reset Model-specific Programming Data for the currently Selected Model back to the Factory Default settings. Make sure that prior to using the Model Clear function, you first Select and load the desired Model you want to clear the Programming Data for, using the Model Select function.

 When the Model Clear function is EXECUTED, all custom Programming Data for the currently Selected Model will be lost and reset to the Factory Default settings!

### Clearing Model Programming Data:

- From within the SYSTEM menu, scroll UP or DOWN to highlight the MODEL menu.
- Press the ENTER key to open the MODEL menu, then scroll UP or DOWN to highlight the CLEAR menu. The currently Selected Model will be displayed.

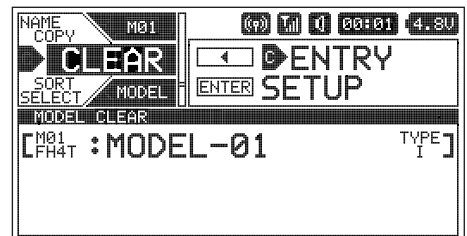
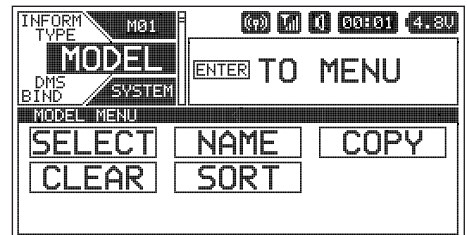

- Press the ENTER key. MODEL CLEAR OK? NO/YES will be displayed. Scroll UP or DOWN to highlight YES, then press the ENTER key. EXECUTED will be displayed and all Programming Data for the currently Selected Model will be reset to the Factory Default settings.

 If you want to go back and change Models or you don't want to Clear the Programming Data for any reason, choose NO or press the BACK key prior to EXECUTING.

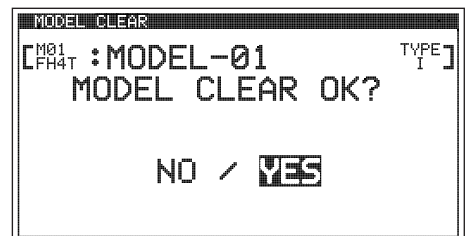

## MODEL MENU (SELECT, NAME, COPY, CLEAR AND SORT)

SYSTEM

### Model Sort

The Model Sort function allows you to change how your Models are displayed in the Model Select List by allowing you to swap the currently Selected Model with other Models. For example, you might want to Sort your Models so that your most frequently used Models are at the top of the Model Select List, or you might want to Sort your Models by type, such as crawlers, on-road, etc.

#### Sorting Models:

- 1) From within the SYSTEM menu, scroll UP or DOWN to highlight the MODEL menu.

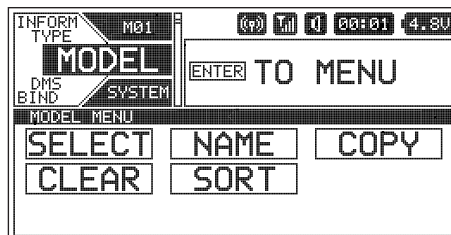

- 2) Press the ENTER key to open the MODEL menu, then scroll UP or DOWN to highlight the SORT menu.

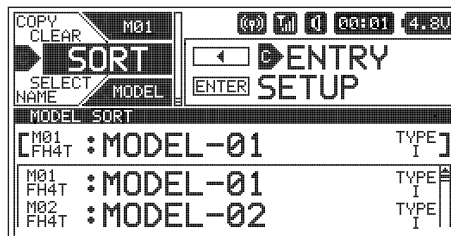

- 3) Press the ENTER key to open the SORT menu. The currently Selected Model will be displayed in brackets above the Model Sort List and the first Model in the Model Sort List will be highlighted.

- 4) Scroll UP or DOWN within the Model Sort List to highlight the Model you would like to swap the currently Selected Model with and move to the top of the Model Sort List. For example, the currently Selected Model is M01. Highlight M02 to swap M01 with M02 and move it to the top of Model Sort List.

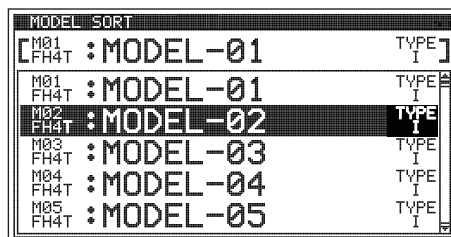

- 5) Press the ENTER key. MODEL SORT OK? NO/YES will be displayed. Scroll UP or DOWN to highlight YES, then press the ENTER key.

 If you want to go back and choose a different Model or you don't want to Sort the Selected Model for any reason, choose NO or press the BACK key prior to EXECUTING.

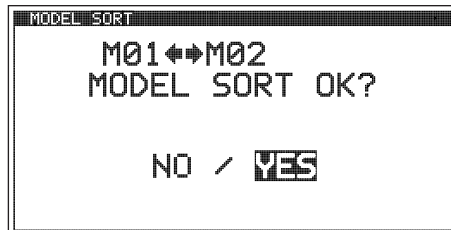

- 6) EXECUTED will be displayed and the Model you highlighted (i.e. M02) will be swapped with the currently Selected Model and moved to the top of the Model Sort List.

- 7) Repeat steps 4 through 6 to continue Sorting Models by swapping with the currently Selected Model. To swap with a different Model, you must Select that desired Model using the Model Select function first. For more information, see the Model Select section on pages 25 ~ 26.

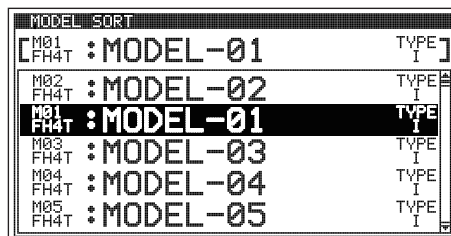

## DMS MENU (DIRECT MODEL SELECT)

SYSTEM

The DMS function allows you to choose up to three different Models that can be Selected when turning the transmitter ON. Simply press a key while turning the transmitter ON and the Programming Data for your favorite Model will load automatically.

#### Using the Direct Model Select Function:

- 1) Turn the transmitter turned OFF.
- 2) Press and HOLD the SELECT switch Right or Left, or press and HOLD the BACK key while turning the transmitter ON. The Model Programming Data associated with either of those key presses will automatically load.



## DMS MENU (DIRECT MODEL SELECT)

SYSTEM

### Changing Direct Model Select Models:

1) From within the SYSTEM menu, scroll UP or DOWN to highlight the DMS menu.

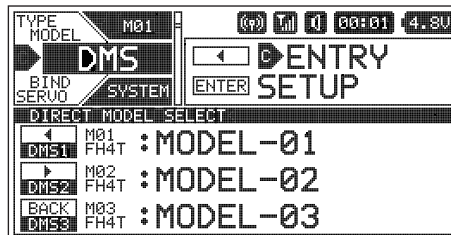

2) Press the ENTER key to open the DMS menu, then scroll UP or DOWN to highlight the Model Name adjacent to the DMS number you would like to change.

SELECT switch LEFT controls DMS1, SELECT switch RIGHT controls DMS2 and the BACK key controls DMS3.

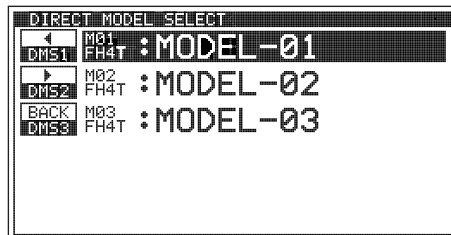

3) Press the ENTER key, then scroll UP or DOWN to choose the Model Name you want to be controlled by that particular Direct Model Select switch.

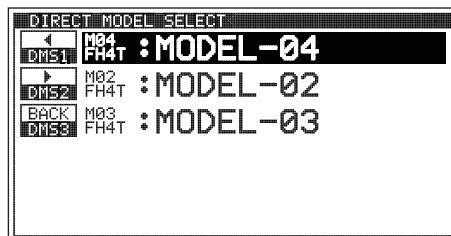

4) Repeat step 3 to Assign any other desired Models to the remaining Direct Model Select Switches.

## BIND MENU (BINDING, MODULATION TYPE, SAFETY LINK AND SERVO MODE)

SYSTEM

The BIND menu allows you to change the transmitter's Modulation Type, turn the Telemetry function ON and OFF, Assign a Safety Link Number to your Model, change the Servo Operating Mode and Bind the transmitter and receiver pair. All settings are Model-specific, so you can have different settings to suit different Models.

**!** The Modulation Type and Safety Link Number must be chosen prior to Binding the transmitter and receiver. If these options are changed after Binding, you will need to re-Bind the transmitter and receiver pair.

Make sure the Modulation Type you choose matches the Modulation Type of the receiver you're using!

### Changing the Modulation Type:

The Modulation Type function allows you to choose the transmitter Modulation Type. The Modulation Type should be changed to match the receiver you're using. For example, if you use an Airtronics 2.4GHz FH3 surface receiver with your transmitter, you would need to change the Modulation Type to FH3. The Modulation Type should be chosen prior to Binding the transmitter and receiver pair.

1) From within the SYSTEM menu, scroll UP or DOWN to highlight the BIND menu.

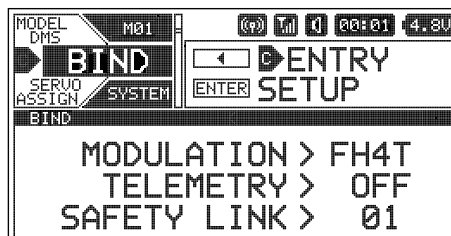

2) Press the ENTER key to open the BIND menu. MODULATION > FH4T will be highlighted.

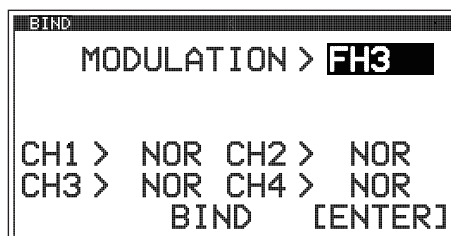

3) Press the ENTER key, then scroll UP or DOWN to Select the desired Modulation Type.

### Changing the Modulation Type, Continued...

- 4) Press the ENTER key. SET TO FH3? (or the Modulation Type you Selected) NO/YES will be displayed. Scroll UP or DOWN to highlight YES, then press the ENTER key.

 If you want to go back and change the Modulation Type or if you don't want to change the Modulation Type for any reason, choose NO or press the BACK key.

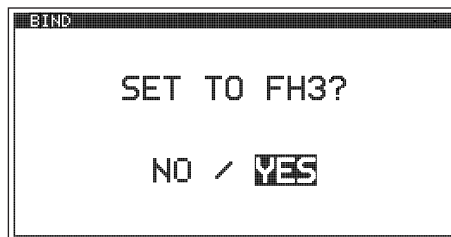

The following Modulation Type options are available:

- FH2** - Select this Modulation Type when using Airtronics 2.4GHz FH2 surface receivers.
- FH3** - Select this Modulation Type when using Airtronics 2.4GHz FH3 surface receivers.
- FH3F** - This Modulation Type is NOT used in North America.
- FH4T (Default)** - Select this Modulation Type when using Airtronics 2.4GHz FH4 or FH4T surface receivers.
- FH4FT** - This Modulation Type is NOT used in North America.

**IMPORTANT:** Not all BIND menu functions are supported by all Modulation Types. Only supported functions will be displayed once a Modulation Type is chosen. For example, the FH3 Modulation Type does not support Telemetry.

### Turning the Telemetry Function ON and OFF:

- 1) From within the BIND menu, scroll down to highlight TELEMETRY > ON.
- 2) Press the ENTER key, then scroll UP or DOWN to choose the desired Telemetry value, either ON or OFF.

TELEMETRY setting range is ON or OFF. The default setting is OFF.

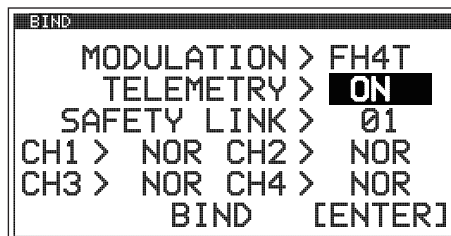

### Changing the Safety Link Number:

The Safety Link function is used to program a unique code to each receiver/Model pair, preventing the transmitter from controlling a Model that it's not currently programmed for. This helps prevent a runaway Model should you accidentally choose the wrong Programming Data for the intended Model.

 The Safety Link Number should be chosen prior to Binding the transmitter and receiver pair. To make it easier to keep track of what Safety Link Number goes to what Model, we suggest making the Safety Link Number the same as the Model Number.

- 1) From within the BIND menu, scroll down to highlight SAFETY LINK > 01.
- 2) Press the ENTER key, then scroll UP or DOWN to highlight the desired Safety Link Number.

SAFETY LINK setting range is 01 to 50. The default setting is 01.

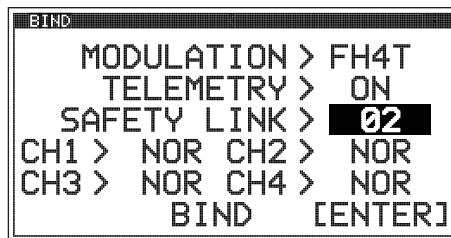

- 3) Press the ENTER key. SET TO LINK No.02? (or the Safety Link Number you Selected) NO/YES will be displayed. Scroll UP or DOWN to highlight YES, then press the ENTER key.

 If you want to go back and change the Safety Link Number or if you don't want to change the Safety Link Number for any reason, choose NO or press the BACK key.

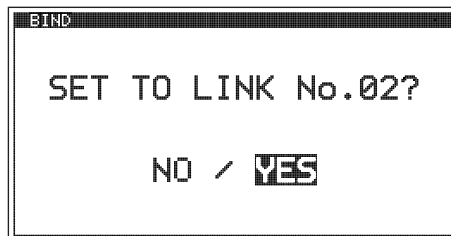

### Changing the Servo Operating Mode:

The Servo Operating Mode function is used to optimize the radio control system to suit the type of servos you're using in your Model. For example, using the SHR setting with Digital servos will Increase the servo's response time, even above the manufacturer's stated specification. If you're using Airtronics SRG Digital servos, you can use the SSR setting for the fastest response time. The combination of using Digital servos and using the correct Servo Operating Mode value results in the ultimate feel and response, making you feel more in control of your Model than ever.



## BIND MENU (BINDING, MODULATION TYPE, SAFETY LINK AND SERVO MODE)

SYSTEM

### Changing the Servo Operating Mode, Continued...

- 1) From within the BIND menu, scroll down to highlight the desired channel you would like to change the Servo Operating Mode for.
- 2) Press the ENTER key, then scroll UP or DOWN to choose the desired Servo Operating Mode value for that channel.
- 3) Press the ENTER key, then repeat steps 1 and 2 to choose the Servo Operating Mode for any desired remaining channels.

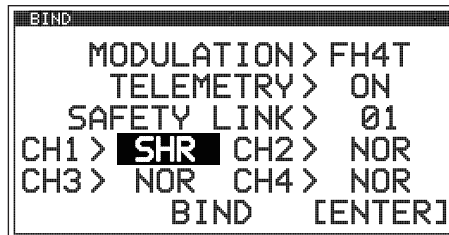
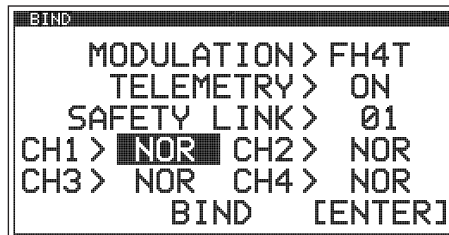

SERVO OPERATING MODE setting range is NOR, SHR and SSR. The default setting is NOR. SSR Operating Mode is not supported when FH3 or FH3F Modulation Type is Selected.

### IMPORTANT INFORMATION ABOUT SERVO OPERATING MODE VALUES:

If you're using Analog servos in your Model, DO NOT use SHR or SSR Servo Operating Mode values for those channels. Use the NOR (Normal) Servo Operating Mode with Analog servos. Using SHR or SSR Servo Operating Mode values with Analog servos can result in poor performance or even damage to the servos or the receiver!

Not all ESCs are compatible with SHR or SSR Servo Operating Modes. If your ESC does not operate correctly, change the Servo Operating Mode to NOR (Normal) for that channel (or channels).

SHR and SSR Servo Operating Modes should only be used with Digital servos. While the SHR Servo Operating Mode can be used with any brand of Digital servo, the SSR Servo Operating Mode should ONLY be used with Airtronics SRG Digital servos.

### Binding the Transmitter and Receiver:

To Bind the transmitter and receiver, please see the *Transmitter and Receiver Binding* section on page 23. Prior to Binding the transmitter and receiver, make sure to choose the desired Modulation Type and Safety Link Number.

## SERVO MENU (SERVO MONITOR)

SYSTEM

The Servo Monitor displays the output levels of the four different channels in bar graph form, allowing you to monitor servo operation in a virtual manner. This is helpful to see servo movement when the controls are moved, and it allows you to visualize what is occurring with servo movements when you apply different Mixing values, exponential, etc. When used in conjunction with the DISPLAY key, the Servo Monitor allows you to see servo movement virtually and make programming changes without the transmitter actually transmitting a signal.

 The channel names displayed will vary based on the Car Type Selected in the TYPE menu. Depending on the current servo reversing settings, the bar graphs may not move the same direction as the transmitter controls. This is normal.

### Using the Servo Monitor:

- 1) From within the SYSTEM menu, scroll UP or DOWN to highlight the SERVO menu.
- 2) Press the ENTER key to open and view the full screen Servo Monitor. The hash marks represent the current channel output positions.

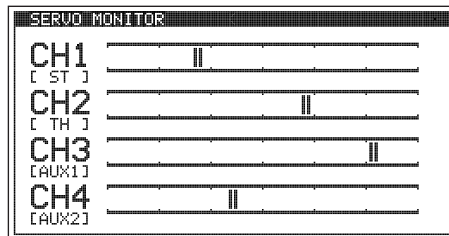
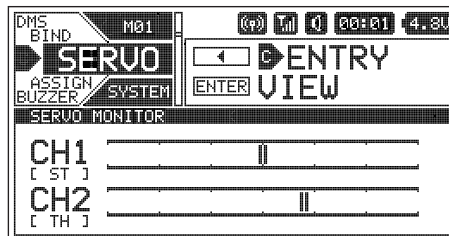

## ASSIGN MENU (SWITCH, DIAL AND LEVER FUNCTION ASSIGNMENTS)

SYSTEM

The ASSIGN menu allows you to Assign different functions to each of the three Push-Button Switches, the five Trim Switches, the Auxiliary Dial and the Auxiliary Lever. Each of the three Push-Button Switches can have up to two functions Assigned to it and the ON/OFF behavior can be changed. In addition, the Direction of Travel and the Trim Resolution of the five Trim Switches and the Auxiliary Dial can be changed.

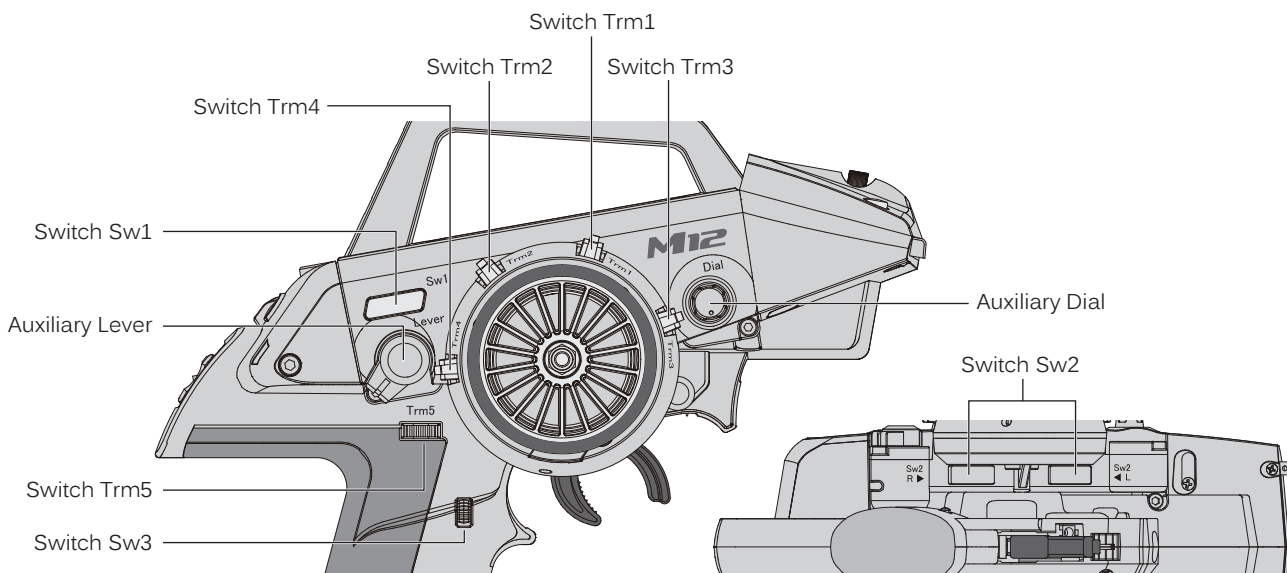

### Push-Button Switch Function Assignments

The Switch Assignments function allows you to Assign various functions to the three Push-Button Switches Sw1, Sw2 and Sw3. This allows you to use the Push-Button Switches to turn functions ON and OFF while you're driving. Up to two different functions can be Assigned to each switch and the ON and OFF behavior of each switch can be changed to either PUSH or TOGGLE to suit the programmed function and your specific requirements.

 Push-Button Switch functions vary based on the Car Type Selected in the TYPE menu. For more information, see the table on the next page.

### Changing the Push-Button Switch Function Assignments:

1) From within the SYSTEM menu, scroll UP or DOWN to highlight the ASSIGN menu.

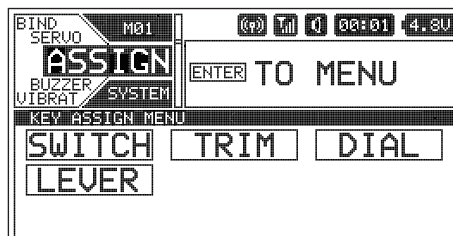

2) Press the ENTER key to open the ASSIGN menu. The SWITCH menu will be highlighted.

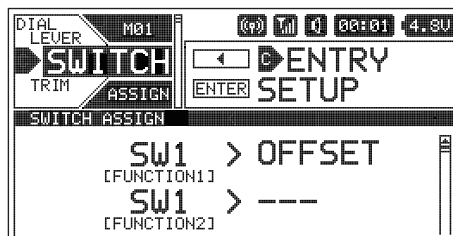

3) Press the ENTER key to open the SWITCH menu. SW1 [FUNCTION 1] > OFFSET will be highlighted.

4) Scroll UP or DOWN to highlight the Switch Number and Function you would like to change. Choose from SW1 [FUNCTION 1 or 2], SW2 [FUNCTION 1 or 2] or SW3 [FUNCTION 1 or 2].

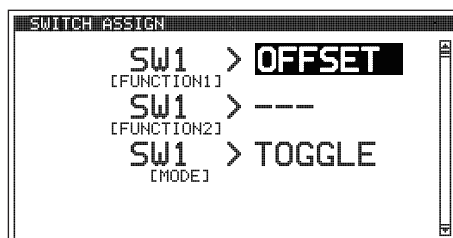

## ASSIGN MENU (SWITCH, DIAL AND LEVER FUNCTION ASSIGNMENTS)

SYSTEM

### Changing the Push-Button Switch Function Assignments, Continued....

- Press the ENTER key, then scroll UP or DOWN to choose the desired function for the Switch and Function Number you highlighted. A list of functions that can be Assigned to the Push-Button Switches are shown in the table below.
- Press the ENTER key, then repeat steps 4 and 5 to any other desired Push-Button Switch Function Assignments.

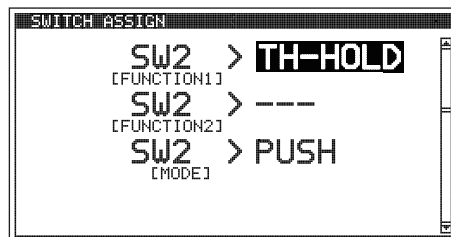

**!** Although two different functions can be Assigned to the same Push-Button Switch, those functions cannot be controlled independently. AUX may control different functions depending on the Car Type.

TYPE SW	TYP I	TYP II	TYP III	TYP IV	TYP V	TYP VI	TYP VII	TYP VIII	TYP IX	TYP X
	---	---	---	---	---	---	---	---	---	---
Sw2*	ALB	ALB	ALB	ALB	ALB	ALB	ALB	ALB	ALB	ALB
Sw1*	OFFSET	OFFSET	OFFSET	OFFSET	OFFSET	OFFSET	OFFSET	OFFSET	OFFSET	OFFSET
	AUX1	AUX	AUX	LAP	AUX	LAP	LAP	AUX	AUX	LAP
	AUX2	LAP	LAP	INT1	LAP	INT1	INT1	LAP	LAP	INT1
Sw3*	LAP	INT1	INT1	INT2	INT1	INT2	INT2	INT1	INT1	INT2
Sw3*	INT1	INT2	INT2	TH-HOLD	INT2	TH-HOLD	TH-HOLD	INT2	INT2	
	INT2	TH-HOLD	TH-HOLD		TH-HOLD					
	TH-HOLD									

\*Indicates default function for Selected Car Type.

### Changing the Switch Mode:

The ON and OFF behavior of each Push-Button Switch can be changed to suit the programmed function and your specific requirements. The following Switch Modes are available:

**TOGGLE** - When Selected, press the Push-Button Switch to turn the function ON and press the Push-Button Switch a second time to turn the function OFF.

**PUSH** - When Selected, press and HOLD the Push-Button Switch to turn the function ON. Release the Push-Button Switch to turn the function OFF.

- From within the SWITCH menu, scroll UP or DOWN to highlight the Switch Number [MODE] you would like to change. Choose from SW1 [MODE], SW2 [MODE] or SW3 [MODE].

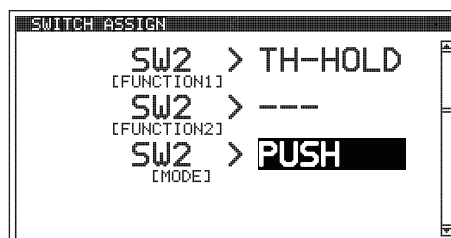

- Press the ENTER key, then scroll UP or DOWN to change the desired Switch Mode value. Choose from either TOGGLE or PUSH.

MODE setting range is PUSH and TOGGLE. The default setting for SW1 is TOGGLE and for SW2 and SW3 is PUSH.

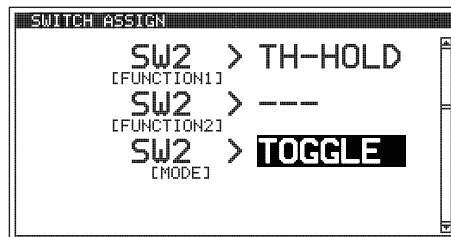

- Repeat step 2 to change any other desired Switch Mode values.

### Trim Switch Function Assignments

The Trim Assignments function allows you to Assign a multitude of different functions to the five Trim Switches Trm1, Trm2, Trm3, Trm4 and Trm5. This allows you to use the Trim Switches to control those functions while you're driving. In addition, the Trim Resolution (Step value) and the Direction of Travel (REV) of each Trim Switch can be changed.

**!** For a complete list of functions that can be Assigned to the Trim Switches, see the Trim Switch Auxiliary Dial and Auxiliary Lever Functions tables on page 100.

## ASSIGN MENU (SWITCH, DIAL AND LEVER FUNCTION ASSIGNMENTS)

SYSTEM

### Changing the Trim Switch Function Assignments:

- 1) From within the SYSTEM menu, scroll UP or DOWN to highlight the ASSIGN menu.

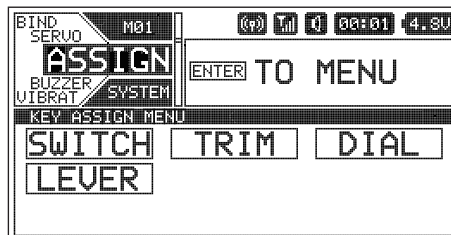

- 2) Press the ENTER key to open the ASSIGN menu, then scroll UP or DOWN to highlight the TRIM menu.

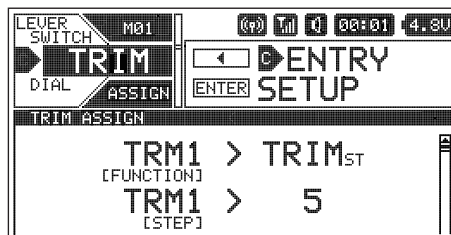

- 3) Press the ENTER key to open the TRIM menu. TRM1 [FUNCTION] > TRIM<sub>ST</sub> will be highlighted.

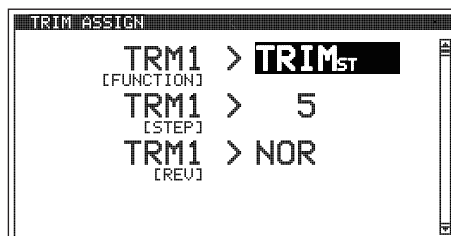

- 4) Scroll UP or DOWN to highlight the Trim Switch Number you would like to change. Choose from TRM1, TRM2, TRM3, TRM4 or TRM5.

- 5) Press the ENTER key, then scroll UP or DOWN to choose the desired function for the Trim Switch Number you highlighted. A complete list of functions that can be Assigned to the Trim Switches are shown in the tables on page 100.

- 6) Press the ENTER key, then repeat steps 4 and 5 to any other desired Trim Switch Function Assignments.

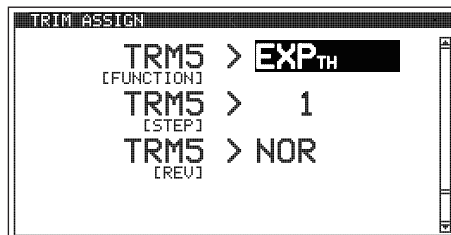

### Changing the Trim Switch Step Value:

The Step function allows you to adjust how far a servo travels or a function moves when a Trim Switch is pressed. You can Increase the Trim Resolution by Decreasing the Step value, so that the amount of travel is less when you press the Trim Switches. This makes it possible to fine-tune travel extremely accurately. Alternately, you could Decrease the Trim Resolution by Increasing the Step value, so that the amount of travel is more when you press the Trim Switches. This may not be as accurate, but it allows you to command large amounts of travel or function movement at a time.

- 1) From within the TRIM menu, scroll UP or DOWN to highlight the Trim Switch Number [STEP] you would like to change. Choose from TRM1 [STEP], TRM2 [STEP], TRM3 [STEP], TRM4 [STEP] or TRM5 [STEP].

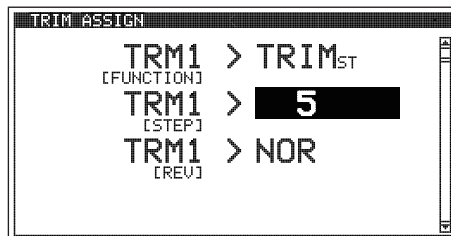

- 2) Press the ENTER key, then scroll UP or DOWN to change the desired Trim Switch Step value.

STEP setting range is 0 to 100. The default setting is 1 or 5 depending on the Trim Switch Number. The Step value is a percentage of travel.

- 3) Repeat step 2 to change any other desired Trim Step values.

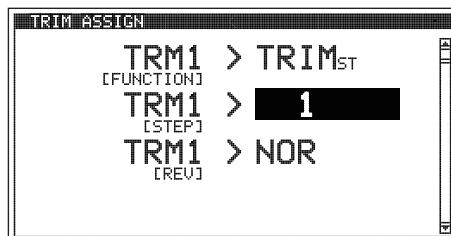

## ASSIGN MENU (SWITCH, DIAL AND LEVER FUNCTION ASSIGNMENTS)

SYSTEM

### Changing the Trim Switch Direction of Travel:

The direction that the Trim Switches move the servos or function values can be changed from Normal to Reverse. In Normal mode, the Trim Switches will move the servos toward the High Side or Increase function values when the Trim Switches are pushed Forward. In Reverse mode, the Trim Switches will move the servos toward the Low Side or Decrease function values when the Trim Switches are pushed Forward.

- 1) From within the TRIM menu, scroll UP or DOWN to highlight the Trim Switch Number [REV] you would like to change. Choose from TRM1 [REV], TRM2 [REV], TRM3 [REV], TRM4 [REV] or TRM5 [REV].

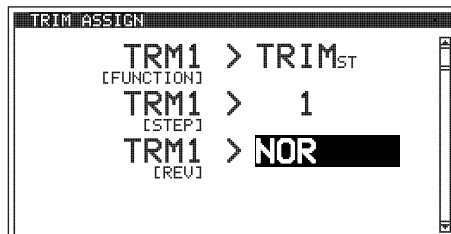

- 2) Press the ENTER key, then scroll UP or DOWN to change the desired Trim Switch Reverse value.

REV setting range is NOR and REV. The default setting is NOR.

- 3) Repeat step 2 to change any other desired Trim Switch Reverse values.

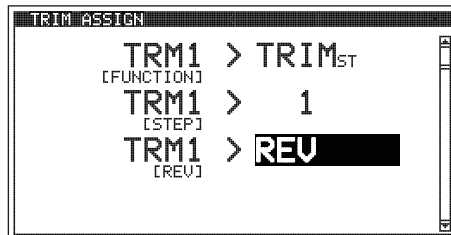

### Auxiliary Dial Function Assignments

The Dial Assignments function allows you to Assign a multitude of different functions to the Auxiliary Dial. This allows you to use the Auxiliary Dial to control those functions while you're driving. The Auxiliary Dial can control either of the two Auxiliary channels or it can control a function, such as Steering Dual Rate or Steering Exponential. In addition, the Trim Resolution (Step value) and the Direction of Travel (REV) of the Auxiliary Dial can be changed.

### Changing the Auxiliary Dial Function Assignment:

- 1) From within the SYSTEM menu, scroll UP or DOWN to highlight the ASSIGN menu.

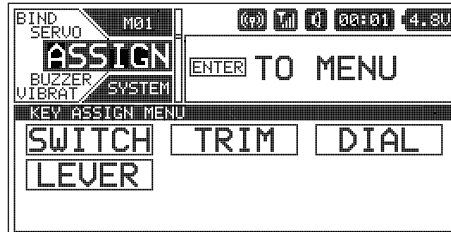

- 2) Press the ENTER key to open the ASSIGN menu, then scroll UP or DOWN to highlight the DIAL menu.

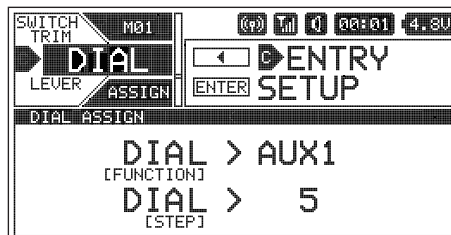

- 3) Press the ENTER key to open the DIAL menu. DIAL [FUNCTION] > AUX1 will be highlighted.
- 4) Press the ENTER key, then scroll UP or DOWN to choose the desired function you want to Assign to the Auxiliary Dial. A complete list of functions that can be Assigned to the Auxiliary Dial is shown in the table on page 100.

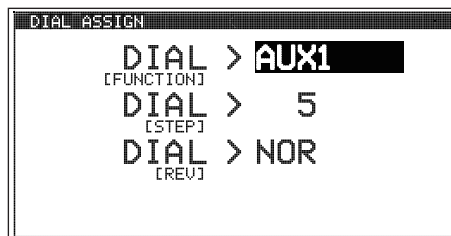

### Changing the Auxiliary Dial Step Value:

The Step function allows you to adjust how far a servo travels or a function moves when the Auxiliary Dial is turned. You can Increase the Trim Resolution by Decreasing the Step value, so that the amount of travel is less when you turn the Auxiliary Dial. This makes it possible to fine-tune servo travel or function movement extremely accurately. Alternately, you could Decrease the Trim Resolution by Increasing the Step value, so that the amount of travel is more when you turn the Auxiliary Dial. This may not be as accurate, but it allows you to command large amounts of servo travel or function movement at a time.

## ASSIGN MENU (SWITCH, DIAL AND LEVER FUNCTION ASSIGNMENTS)

SYSTEM

### Changing the Auxiliary Dial Step Value, Continued:

- 1) From within the DIAL menu, scroll UP or DOWN to highlight DIAL [STEP] > 5.
- 2) Press the ENTER key, then scroll UP or DOWN to choose the desired Auxiliary Dial Step value.



STEP setting range is 1 to 100. The default setting is 5. The Step value is a percentage of travel.

### Changing the Auxiliary Dial Direction of Travel:

The direction that the Auxiliary Dial moves the servo or function value can be changed from Normal to Reverse. In Normal mode, the Auxiliary Dial will move the servo toward the High Side or Increase a function value when the Auxiliary Dial is turned clockwise. In Reverse mode, the Auxiliary Dial will move the servo toward the Low Side or Decrease a function value when the Auxiliary Dial is turned counter-clockwise.

- 1) From within the DIAL menu, scroll UP or DOWN to highlight DIAL [REV] > NOR.
- 2) Press the ENTER key, then scroll UP or DOWN to choose the desired Auxiliary Dial Reverse value.

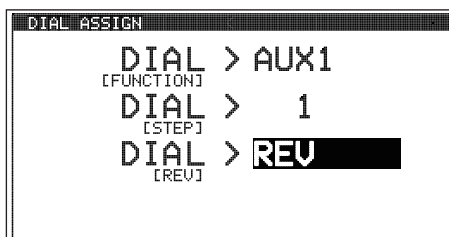

REV setting range is NOR and REV. The default setting is NOR.

### Auxiliary Lever Function Assignments

The Lever Assignments function allows you to Assign various functions to the Auxiliary Lever. This allows you to use the Auxiliary Lever to control those functions while you're driving. The Auxiliary Lever can control either of the two Auxiliary channels or it can control a function, such as Steering Dual Rate or Steering Exponential.

Changing the High and Low Tweak values determines the amount of travel and direction.

### Changing the Auxiliary Lever Function Assignment:

- 1) From within the SYSTEM menu, scroll UP or DOWN to highlight the ASSIGN menu.

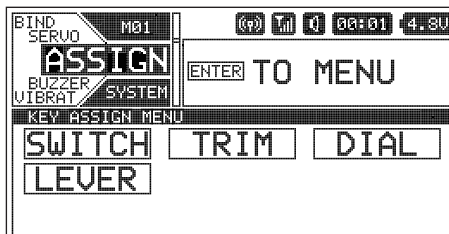

- 2) Press the ENTER key to open the ASSIGN menu, then scroll UP or DOWN to highlight the LEVER menu.

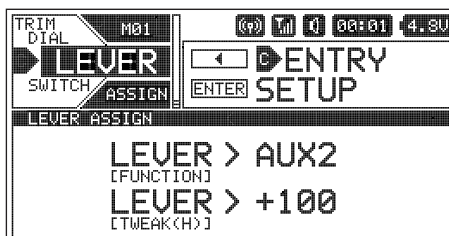

- 3) Press the ENTER key to open the LEVER menu. LEVER [FUNCTION] > AUX2 will be highlighted.
- 4) Press the ENTER key, then scroll UP or DOWN to choose the desired function you want to Assign to the Auxiliary Lever. A complete list of functions that can be Assigned to the Auxiliary Lever are shown in the tables on page 100.

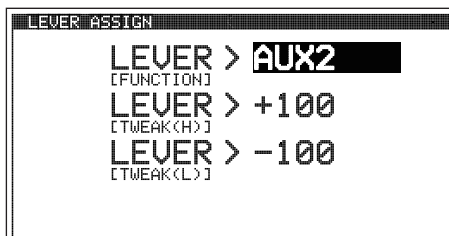



## ASSIGN MENU (SWITCH, DIAL AND LEVER FUNCTION ASSIGNMENTS)

SYSTEM

### Changing the Auxiliary Lever High and Low Tweak Values:

The High and Low Tweak values both determine how far and in which direction the Auxiliary Lever controls the function Assigned to it when the Auxiliary Lever is moved Up and Down, regardless if the Auxiliary Lever is controlling a servo, such as Auxiliary Channel 2 or a function parameter, such as Steering Trim. For example, if you Assign AUX2 to the Auxiliary Lever and adjust the Tweak values to +50 and -50, the Auxiliary 2 servo will be centered when the Auxiliary Lever is centered and will travel 50% in one direction when the Auxiliary Lever is moved Up and travel 50% in the other direction when the Auxiliary Lever is moved Down. Alternately, if you Assign TRIMst to the Auxiliary Lever and adjust the Tweak values to +50 and -50, the Auxiliary Lever will control Steering Trim from 0% to 50%.

- 1) From within the LEVER menu, scroll UP or DOWN to highlight LEVER [TWEAK (H)] > +100.
- 2) Press the ENTER key, then scroll UP or DOWN to choose the desired High Side Tweak value. Increasing the Tweak value will Increase travel in the High Side direction and Decreasing the Tweak value will Decrease travel in the High Side direction. Using a Negative value will change the direction of travel.

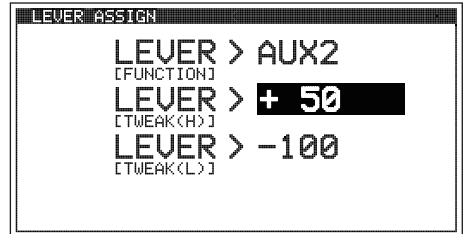

TWEAK (H) setting range is -100 to +100. The default setting is +100.

- 3) Scroll DOWN to highlight LEVER [TWEAK (L)] > -100.
- 4) Press the ENTER key, then scroll UP or DOWN to choose the desired Low Side Tweak value. Decreasing the Tweak value will Increase travel in the Low Side direction and Increasing the Tweak value will Decrease travel in the Low Side direction. Using a Positive value will change the direction of travel.

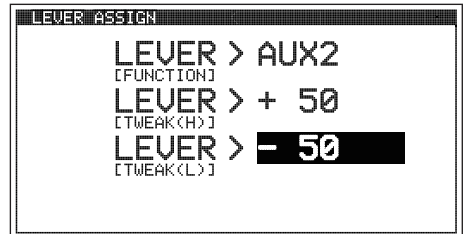

TWEAK (L) setting range is -100 to +100. The default setting is -100.

## BUZZER MENU (AUDIBLE KEY TONES AND ALARMS)

SYSTEM

The Buzzer function allows you to change the Tone and Volume of many of the audible sounds that the transmitter makes. This ranges from sounds that are made when you press Trim and Push-Button Switches, scroll UP or DOWN or press the ENTER key, Lap and Interval Timer alarms, Telemetry alarms, transmitter Voltage Limit alarm and more.

The Volume can be Increased or Decreased (or Muted) and the Tones can be changed to suit your preference. In addition, many of the Tones can be set separately for the first half and the second half of a Tone, making it easier to differentiate between the two halves.

The following is a list of the functions that the Tone and Volume can be adjusted for:

FUNCTION	DESCRIPTION
CLICK	Controls Key Press Tones, Such as ENTER, BACK, SELECT and All Push-Button Switches
TRIM	Controls All Trim Switch Key Press Tones
CENTER	Controls the Trim Switch, Auxiliary Dial and Auxiliary Lever Neutral Point Indicator Tones
MULTI	Controls the Push-Button Rotary Dial scroll UP and Scroll DOWN Tones*
TIMER SW	Controls the Lap Timer Start and Stop Tones*
INT1 TIMER	Controls the First Interval Timer Start and Stop Tones
INT2 TIMER	Controls the Second Interval Timer Start and Stop Tones
LAP-PRE	Controls the Lap Timer Pre-Alarm Tone
LAP GOAL	Controls the Lap Timer Goal Alarm Tone
OFFSET	Controls the Offset Function Alarm Tone
TELEMETRY	Controls the Various Telemetry System Alarms*
LIMIT	Controls the Transmitter Limit Voltage Alarm*

\*Only TONE1 (first half) changes affected. No affect on TONE2 (second half) changes.

## BUZZER MENU (AUDIBLE KEY TONES AND ALARMS)

SYSTEM

### Changing the Audible Tones:

- From within the SYSTEM menu, scroll UP or DOWN to highlight the BUZZER menu.
- Press the ENTER key to open the BUZZER menu. CLICK [TONE1] > 1 will be highlighted.
- Scroll UP or DOWN to highlight the Function Tone Number you would like to change.
- Press the ENTER key, then scroll UP or DOWN to choose the desired Tone value for either [TONE1] and/or [TONE2]. Increasing the Tone value will Increase the Tone of the Selected function and Decreasing the Tone value will Decrease the Tone of the Selected function.

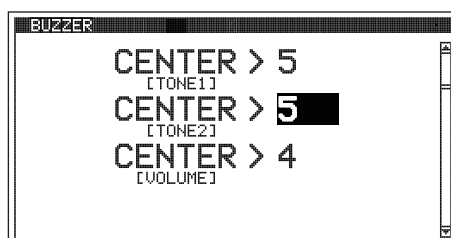
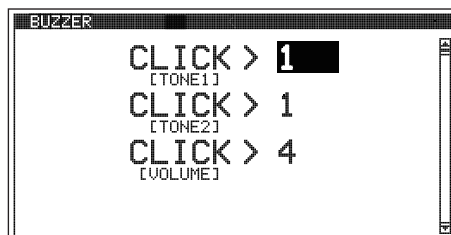
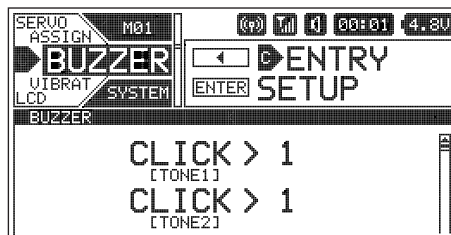

TONE1 and TONE2 setting range is 1 to 7. The default setting is 1. TONE1 changes the first half Tone and TONE2 changes the second half Tone.

- Press the ENTER key, then repeat steps 3 and 4 to change the Audible Tones for any other desired functions.

### Changing the Volume:

- From within the BUZZER menu, Scroll UP or DOWN to highlight the Function Volume Number you would like to change.
- Press the ENTER key, then scroll UP or DOWN to choose the desired Volume value. Increasing the Volume value will Increase the Volume of the Selected function and Decreasing the Volume value will Decrease the Volume of the Selected function. Choosing OFF will Mute the Selected function.

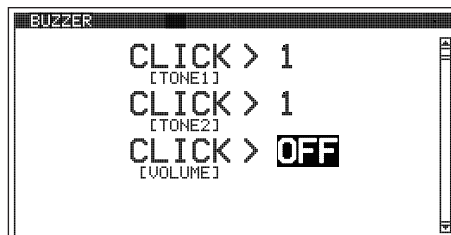
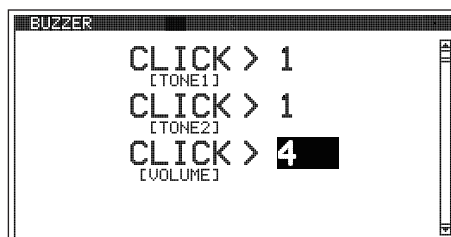

VOLUME setting range is OFF to 5. The default setting is 4.

- Press the ENTER key, then repeat steps 1 and 2 to change the Volume value for any other desired functions.

## VIBRATOR MENU (VIBRATION ALERTS AND ALARMS)

SYSTEM

The Vibrator function makes the transmitter vibrate like a cell phone to make you aware of different alerts and alarms that you might encounter during use. For example, you can program the transmitter to vibrate when the an Interval Timer starts or stops or when you reach a Lap Timer Goal Time. You can also program the transmitter to vibrate when the transmitter reaches the programmed Voltage Alert value or when the transmitter is turned ON and more. The Vibrate function is particularly useful if you've Muted any of these related audible alerts and alarms. The Vibrate function can also be used along with these related audible alerts and alarms to provide a level of tactile feedback while you're driving.

## VIBRATOR MENU (VIBRATION ALERTS AND ALARMS)

SYSTEM

### Turning Vibration Functions ON and OFF:

- 1) From within the SYSTEM menu, scroll UP or DOWN to highlight the VIBRATOR menu.
- 2) Press the ENTER key to open the VIBRATOR menu. POWER > OFF will be highlighted.
- 3) Scroll UP or DOWN to highlight the function you would like to change the Vibration value for.
- 4) Press the ENTER key, then scroll UP or DOWN to choose the desired Vibration value, either ON or OFF.

VIBRATOR setting range is OFF to ON. The default setting for all functions is OFF.

- 5) Press the ENTER key, repeat steps 3 and 4 to change the Vibration value for any other desired functions.

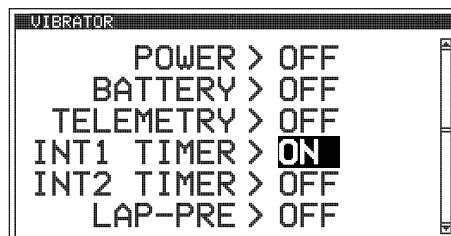
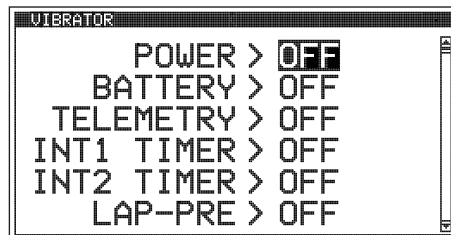
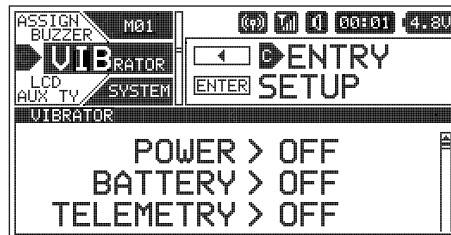

The following is a list Vibration Functions that can be turned ON or OFF:

FUNCTION	DESCRIPTION
POWER	Vibrates When the Transmitter is Turned ON
BATTERY	Vibrates to Indicate When the Transmitter Reaches the Programmed Voltage Alert Value
TELEMETRY	Vibrates to Indicate Telemetry System Alarms
INT1 TIMER	Vibrates to Indicate When the First Interval Timer Starts and Stops
INT2 TIMER	Vibrates to Indicate When the Second Interval Timer Starts and Stops
LAP-PRE	Vibrates to Indicate When the Lap Timer Pre-Alarm Time is Reached
LAP GOAL	Vibrates to Indicate When the Lap Timer Goal Time is Reached

## LCD MENU (DISPLAY OPTIONS)

SYSTEM

The LCD menu allows you change the contrast of the LCD, the brightness of the LCD Backlight, the Backlight Mode and the Backlight On-Time. Changing the Contrast and Brightness settings can make it easier to view the LCD in different lighting conditions and changing the Backlight Mode and Backlight On-Time affects how the Backlight is turned ON and how long the Backlight stays ON.

**IMPORTANT:** Increasing the brightness of the LCD Backlight and/or leaving the LCD Backlight ON at all times will increase battery consumption. In addition, Decreasing the Contrast value near the Lower limit can result in the LCD text becoming difficult to read. Be careful not to set the Contrast value too low.

### Changing the LCD Contrast:

- 1) From within the SYSTEM menu, scroll UP or DOWN to highlight the LCD menu.

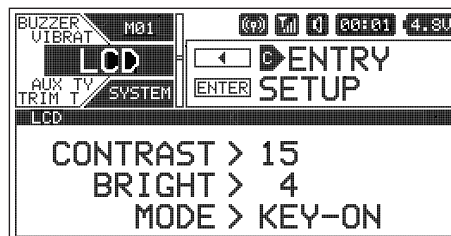

## LCD MENU (DISPLAY OPTIONS)

SYSTEM

### Changing the LCD Contrast, Continued...

2) Press the ENTER key to open the LCD menu. CONTRAST > 15 will be highlighted.

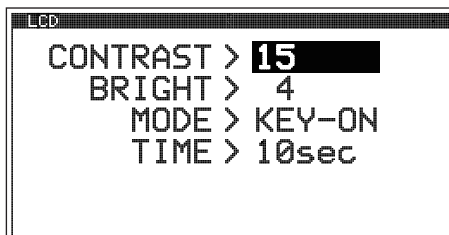

3) Press the ENTER key, then scroll UP or DOWN to choose the desired Contrast value. Increasing the Contrast value will Increase the contrast of the LCD and Decreasing the Contrast value will Decrease the contrast of the LCD.

CONTRAST setting range is 10 to 20. The default setting is 15.



### Changing the LCD Backlight Brightness:

- 1) From within the LCD menu, scroll UP or DOWN to highlight BRIGHT > 4.
- 2) Press the ENTER key, then scroll UP or DOWN to choose the desired Brightness value. Increasing the Brightness value increases the brightness of the LCD Backlight and Decreasing the Brightness value decreases the brightness of the LCD Backlight.

BRIGHT setting range is 1 to 5. The default setting is 4.



### Changing the LCD Backlight Mode:

- 1) From within the LCD menu, scroll UP or DOWN to highlight MODE > KEY-ON.
- 2) Press the ENTER key, then scroll UP or DOWN to choose the desired LCD Mode value. Choose from OFF, KEY-ON or ALWAYS. When set to OFF, the LCD Backlight will be turned OFF. When set to KEY-ON, the LCD Backlight will turn ON when a key-press is made. When set to ALWAYS, the LCD Backlight will stay ON at all times

MODE setting range is OFF, KEY-ON and ALWAYS. The default setting is KEY-ON.

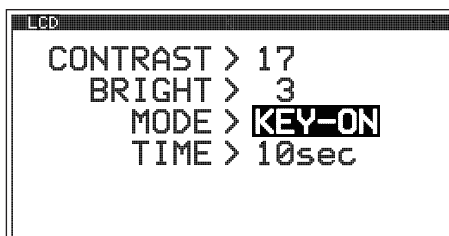

### Changing the LCD Backlight On-Time:

- 1) From within the LCD menu, scroll UP or DOWN to highlight TIME > 10sec.
- 2) Press the ENTER key, then scroll UP or DOWN to choose the desired LCD Time value. The Time value (in seconds) determines how long the LCD Backlight will stay ON before turning OFF automatically. This helps save battery power.

TIME setting range is 1 to 30 seconds. The default setting is 10 seconds.



## AUX TYPE MENU (AUXILIARY CHANNEL OPERATING MODE)

SYSTEM

The Auxiliary Type function allows you choose the Operating Mode for Auxiliary 1 and Auxiliary 2, making it possible to change the way these two Auxiliary channels function.

 This section details how to change the Operating Mode of the two Auxiliary channels. For details about programming and using each of the Auxiliary functions, see the *POINT AUX 1 Menu* section on pages 64 ~ 65, the *POINT AUX 2 Menu* section on pages 65 ~ 66 or the *CODEAX1 and CODEAX2 Menu* section on page 93.

## AUX TYPE MENU (AUXILIARY CHANNEL OPERATING MODE)

SYSTEM

The Operating Mode of Auxiliary 1 and Auxiliary 2 can be changed to suit your specific requirements. The following Operating Modes are available:

**NOR** - When Selected, the Auxiliary channel(s) operate as Normal proportional linear channels, like the Throttle or Steering channels.

**POINT** - When Selected, up to six Point positions can be programmed along the entire length of servo travel. You are then able to cycle back and forth through those Point positions. This option is ideal if your Model requires a three or more position switch to operate a feature. This mode is not proportional. It's a 'Stepping' mode.

**CODE** - This option is for use with future connected products, such as an ESC, whose Programming Parameters can be changed directly via the transmitter. For example, you might be able to change the connected ESC's Driving Modes directly using the Auxiliary Dial to suit different conditions while you're driving.

 Depending on the Car Type Selected in TYPE menu, Auxiliary 2 options may not be available. This is normal.

### Changing the Auxiliary Channel Operating Mode:

- 1) From within the SYSTEM menu, scroll UP or DOWN to highlight the AUX TYPE menu.
- 2) Press the ENTER key to open the AUX TYPE menu. AUX1 > NOR will be highlighted.
- 3) Scroll UP or DOWN to choose which Auxiliary Channel you want to change the Operating Mode for, either AUX1 or AUX2.
- 4) Press the ENTER key, then scroll UP or DOWN to choose the desired Auxiliary 1 or Auxiliary 2 Operating Mode.

AUX1 and AUX2 setting range is NOR, POINT and CODE. The default setting for both AUX1 and AUX2 is NOR.

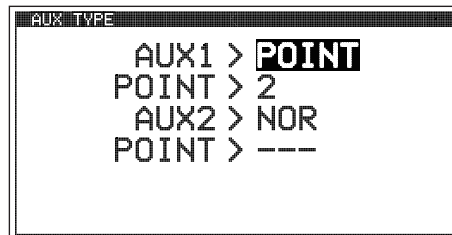
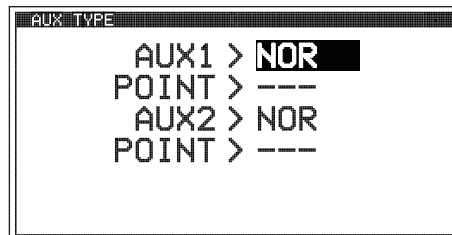
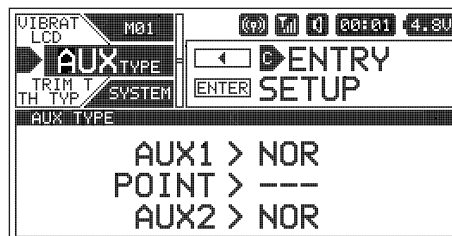

### Changing the Number of Points Value:

After changing the Auxiliary 1 or Auxiliary 2 Operating Mode to POINT, you are able to change the number of points you want the servo to travel through. For example, if you want to be able to cycle your servo from 0 to 20 to 40 to 60 degrees and back again, choose POINT > 4.

 When AUX1 and AUX2 values are set to NOR or CODE, POINT options cannot be programmed.

- 1) After choosing the POINT option, scroll UP or DOWN to the desired POINT value, either AUX1 POINT or AUX2 POINT.
- 2) Press the ENTER key, then scroll UP or DOWN to choose the desired number of Point positions to program.

POINT setting range is 2 to 6. The default setting is 2.

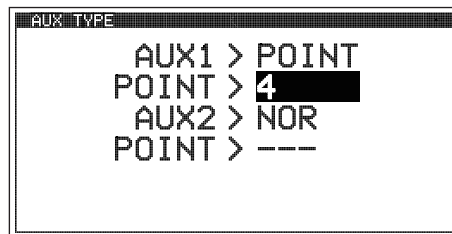

**IMPORTANT:** When set to POINT, please observe the following: We recommend using either the Auxiliary Dial or one of the Trim Switches to operate the Auxiliary channel. The Auxiliary Lever is not suitable for use in this situation. In addition, the Step value for the Auxiliary Dial and/or Trim Switch should be set to 1, otherwise the transmitter won't cycle properly through the programmed Points.

## TRIM TYPE MENU (SERVO TRIM TYPE)

SYSTEM

The Trim Type function allows you choose the way servo Trim and servo End Point Adjustments interact with each other. When you apply Trim to a servo, the Neutral Point of the servo shifts toward the High Side or the Low Side. When you do this, the servo travels less in one direction and more in the other direction because the servo End Points are stationary. In order to balance the servo travel, you would need to manually readjust the servo End Points. Using the Trim Type function allows you to make the servo End Points shift toward the High Side or the Low Side when you apply Trim. This maintains balanced servo travel without the need to manually readjust the servo End Points.

 The Trim Type function does not effect servo Sub-Trim. It only effects servo Trim that's input using the Trim Switches, Auxiliary Dial or Auxiliary Lever. Servo Sub-Trim, which is different, always uses Parallel Trim.

Two Trim Types are available:

**CENTER** - When Selected, servo End Points are stationary. In order to balance servo travel, you would need to manually readjust the servo End Points, if desired.

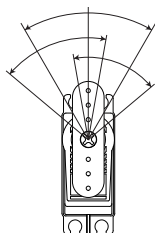

**PARALLEL** - When Selected, servo End Points shift toward the High Side or the Low Side automatically when you apply Trim. This maintains balanced servo travel without the need to manually readjust the servo End Points.

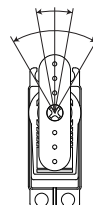

### Changing the Trim Type:

- From within the SYSTEM menu, scroll UP or DOWN to highlight the TRIM TYPE menu.
- Press the ENTER key to open the TRIM TYPE menu. ST > CENT will be highlighted.
- Scroll UP or DOWN to highlight the desired channel you would like to change the Trim Type value for. Choose from either ST (Steering), TH (Throttle), AUX1 (Auxiliary 1) or AUX2 (Auxiliary 2).
- Press the ENTER key, then scroll UP or DOWN to choose the desired Trim Type value for that channel.
- Press the ENTER key, then repeat steps 3 and 4 to change the Trim Type value for any other desired channels.

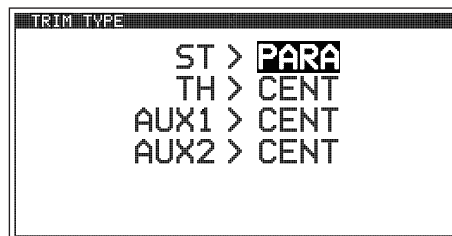
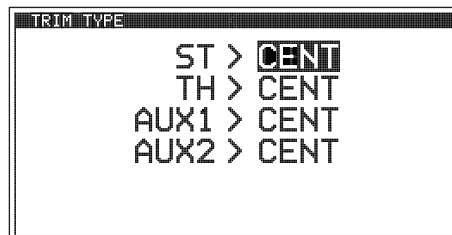
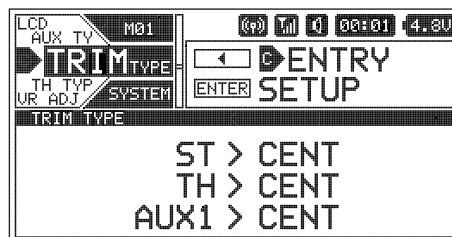

TRIM TYPE setting range is CENT and PARA. The default setting for all channels is CENT.

## TH TYPE MENU (THROTTLE BIAS RATIO)

SYSTEM

The Throttle Type function allows you to change the ratio between Throttle High Side servo travel and Throttle Brake Side servo travel. In the default configuration, the Throttle Type is set to F70:B30. This Throttle Type shifts the Throttle Neutral Point toward the Brake Side, resulting in more servo travel toward the High Side and less servo travel toward the Brake Side.

Some users may prefer the ratio between Throttle High Side servo travel and Throttle Brake Side servo travel to be balanced (F50:B50) so that servo travel is equal. The F70:B30 Throttle Type is most common for general use and racing, while the F50:B50 Throttle Type is most common for Rock Crawling.



## TH TYPE MENU (THROTTLE BIAS RATIO)

SYSTEM

Two Throttle Types are available:

**F70:B30** - When Selected, the Throttle Neutral Point is shifted toward the Brake Side which provides more High Side servo travel and less Brake Side servo travel. This is most common for general use and racing.

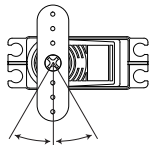
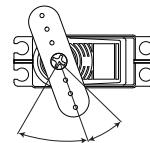

**F50:B50** - When Selected, the Throttle Neutral Point is centered, which provides the same amount of High Side and Brake Side servo travel. This is most common for Rock Crawling.

### Changing the Throttle Type:

- 1) From within the SYSTEM menu, scroll UP or DOWN to highlight the TH TYPE menu.

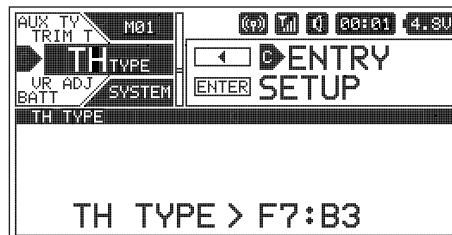

- 2) Press the ENTER key to open the TH TYPE menu. TH TYPE > F7:B3 will be highlighted.

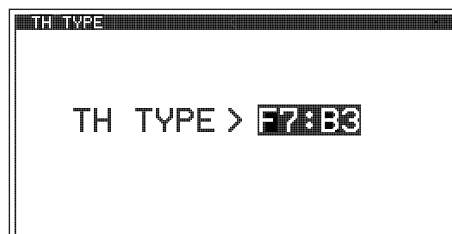

- 3) Press the ENTER key, then scroll UP or DOWN to choose the desired Throttle Type value.

TH TYPE setting range is F7:B3 and F5:B5. The default setting is F7:B3.



- 4) Press the ENTER key. Either Set to F70:B30? NO/YES will be displayed or Set to F50:B50? NO/YES will be displayed. Scroll UP or DOWN to highlight YES, then press the ENTER key.

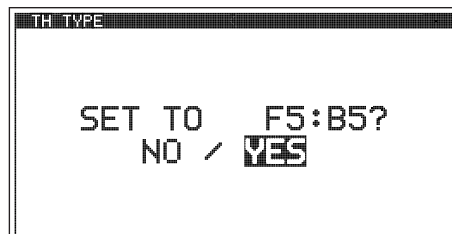

If you want to go back and change the Throttle Type or if you don't want to change the Throttle Type for any reason, choose NO or press the BACK key.

## VR ADJUST MENU (VARIABLE RATE ADJUSTMENT)

SYSTEM

The Variable Rate Adjustment function allows you to calibrate the operation of the Steering Wheel, Throttle Trigger and Auxiliary Lever End Points and Neutral positions. Over time, it's possible that the End Points and/or Neutral positions of these controls may change slightly or you may purposely limit the travel of the Steering Wheel to suit the best feel of the Steering Wheel and your driving style. Being able to calibrate these controls ensures precise operation at all times and in all conditions.

In addition to being able to store custom Variable Rate Adjustment values, you are also able to reset the Variable Rate Adjustment values back to the Factory Default values.

We recommend using the Variable Rate Adjustment function as part of a periodic maintenance schedule or after adjusting the Steering Wheel travel as described in the *Steering Wheel Travel Adjustment* section on page 12.

**IMPORTANT:** After using the Variable Rate Adjustment function, you should double-check the End Point Adjustments of each saved Model. If the End Points have moved, they will need to be readjusted using the End Point Adjustment function.

## VR ADJUST MENU (VARIABLE RATE ADJUSTMENT)

SYSTEM

 The steps required to calibrate the operation of the Steering Wheel, Throttle Trigger and Auxiliary Lever are the same. The example shown in this section details calibrating the Steering Wheel.

Two Variable Rate Adjustment Options are available:

**FACTORY** - When Selected, control End Points and Neutral positions are set to the original Factory Default calibration values. This option should be used if there is a problem with the User calibration values or you want to restore the Factory Default calibration values.

**USER** - When Selected, the user manually calibrates the control End Points and Neutral positions. This option should be used in most all cases as part of a maintenance schedule or if you've limited or otherwise adjusted the travel of the Steering Wheel.

### Calibrating the Steering, Throttle and Auxiliary Lever Controls:

- From within the SYSTEM menu, scroll UP or DOWN to highlight the VR ADJUST menu.

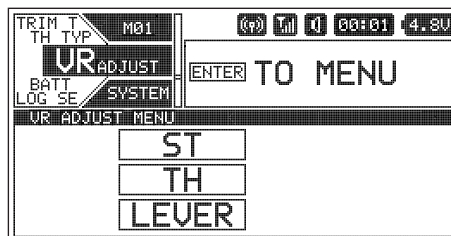

- Press the ENTER key to open the VR ADJUST menu. The ST (Steering) menu will be highlighted.

 If you want to calibrate a different control, scroll UP or DOWN to highlight the control menu option you would like to calibrate, either TH (Throttle) or LEVER (Auxiliary Lever).

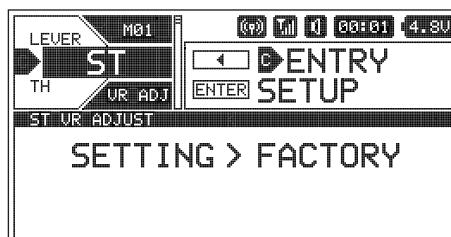

- Press the ENTER key to open the ST VR ADJUST menu (or the TH VR ADJUST menu or the LEVER VR ADJUST menu, depending on your selection in step 2). SETTING > FACTORY will be highlighted.



- Press the ENTER key, then scroll UP to highlight SETTING > USER. Calibration value information specific to the control you're calibrating will be displayed. If you're calibrating the Steering Wheel, NEUT >, LEFT and RIGHT values will be displayed. If you're calibrating the Throttle Trigger, NEUT >, HIGH and BRAKE values will be displayed and if you're calibrating the Auxiliary Lever, NEUT >, HIGH and LOW values will be displayed.

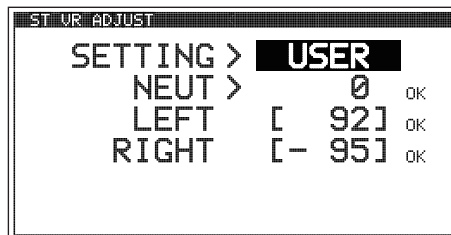

**IMPORTANT:** When completing the steps below, do not complete the steps out of order or the calibration process may not work correctly.

- To calibrate the control's Neutral Point, scroll DOWN to highlight NEUT > 0. Depending on the current state of calibration, a value other than 0 may be displayed.

- With the Steering Wheel (or Throttle Trigger or Auxiliary Lever) centered, press the ENTER key. NEUT > 0 OK will be displayed.

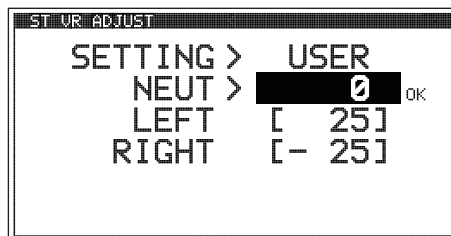

## VR ADJUST MENU (VARIABLE RATE ADJUSTMENT)

SYSTEM

### Calibrating the Steering, Throttle and Auxiliary Lever Controls, Continued....

- 7) Slowly move the Steering Wheel( or Throttle Trigger or Auxiliary Lever) all the way in one direction. Allow the control to return to Neutral, then slowly move the Steering Wheel, Throttle Trigger or Auxiliary Lever all the way in the opposite direction. A series of values and ADJUST OK? NO/YES will be displayed.

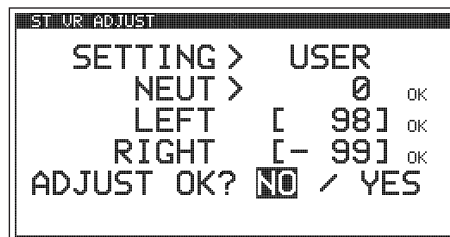

- 8) Scroll UP or DOWN to highlight YES, then press the ENTER key. After the calibration process completes, NEUT > 0 will be highlighted.

 If you want to go back and repeat the calibration process or if you don't want to finish the calibration process for any reason, choose NO or press the BACK key.

- 9) Press the BACK key to return to the VR ADJUST menu and repeat steps 2 through 7 to calibrate the remaining controls.

### Resetting the Steering, Throttle and Auxiliary Lever Calibration Values:

The calibration values can be reset to the Factory Default values quickly and easily should you require it.

- 1) From within the VR ADJUST menu, scroll UP or DOWN to highlight the control menu option you would like to reset the calibration values for, either ST (Steering), TH (Throttle) or LEVER (Auxiliary Lever).

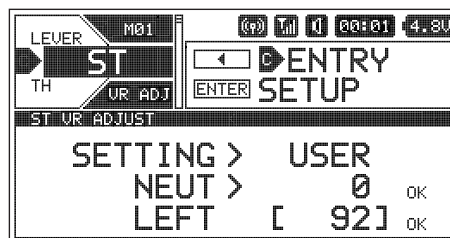

- 2) Press the ENTER key. SETTING > USER will be highlighted.

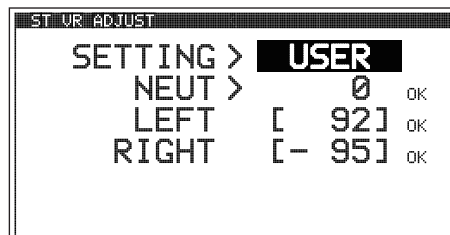

- 3) Press the ENTER key, then scroll DOWN to choose the SETTING > FACTORY option.
- 4) Press the ENTER key. The calibration values for that control will be reset to the Factory Default values.
- 5) Press the BACK key to return to the VR ADJUST menu and repeat steps 1 through 5 to reset the desired remaining controls.

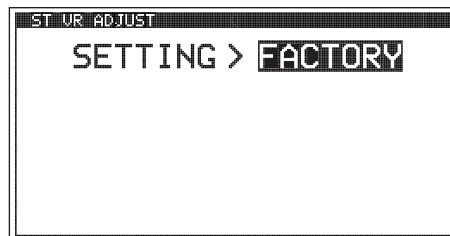

## BATT MENU (LOW VOLTAGE ALERT AND LIMIT ALARMS)

SYSTEM

The BATT menu allows to specify the voltage at which the Low Voltage Alert and Low Voltage Limit alarms will sound. This allows you to choose custom Low Voltage values to match the type of transmitter battery you're using. For example, if you're using a 2S Li-Po battery pack, you can set the Low Voltage Alert alarm and the Low Voltage Limit alarm voltage values to suit.

The tables below show the different Low Voltage Alert and Low Voltage Limit values we recommend using:

BATTERY TYPE	ALERT VALUE	LIMIT VALUE
4 Cell Alkaline	4.6 Volts	4.4 Volts
6 Cell Ni-CD/Ni-MH	7.0 Volts	6.6 Volts

BATTERY TYPE	ALERT VALUE	LIMIT VALUE
2S Li-Po	7.2 Volts	6.8 Volts
2S Li-Fe/A123	6.3 Volts	5.8 Volts

 To ensure the safety of your transmitter battery, we suggest using the Low Voltage Alert and Low Voltage Limit values shown in the tables above. We don't suggest using values Lower than recommended.