

TABLE OF CONTENTS

This equipment has been tested in accordance with the requirements contained in the appropriate Commission regulations. To the best of our knowledge, these tests were performed using measurement procedures consistent with industry or Commission standards and demonstrate that the equipment complies with the appropriate standards. Each unit manufactured, imported or marketed, as defined in the Commission's regulations, will conform to the sample(s) tested within the variations that can be expected due to quality production and testing on a statistical basis.

We further certify that the necessary measurements were made by Kansai Electronic Industry Development Center, Ikoma Emission Measurement Station, 10830, Takayama-Cho, Ikoma-City, Nara, 630-01 Japan.

SECTION I INTRODUCTION

Page #			
5	RDS8000 Radio Control System	13	Precautions on using the 2.4 GHz band
5	2.4 GHz system	13	General precautions for use
5	RDS8000 Transmitter/Receiver Specifications	13	Precautions for use: Transmitter/Receiver
6	Academy of Model Aeronautics	15	Trainer System
6	FCC Compliance Statement	16	Using the RDS8000 Micro-Processor
6	Initial Preparation	16	Pairing (Binding)
7	RDS8000 Transmitter Features	18	Failsafe
8	Transmitter Features and functions	18	Range Check Mode
9	Airborne System Connections	19	Bar Graph Voltage Indicator
9	NiCd Battery Charging	20	AERO Features Description
10	Airborne Components	21	HELI Features Description
10	Connectors		
10	Audio Low Voltage Alarm		
11	Transmitter Battery Removal		
11	Throttle High Warning		
11	Transmitter Stick Length Adjustment		
12	Transmitter Stick Tension Adjustment		

SECTION II AIRPLANE

22	Implementation of Control Function	45	Flaperons
22	Servo Reversing	47	Alarms
23	Control Centering	48	Delta (Elevons)
24	Data Reset	49	Aileron to Rudder Mix
25	Model Select	50	V-Tail (Rudder to Elevator Mix)
26	Stop Watch	51	Throttle to Elevator Mix
27	Integral Timer	52	Compensation Mixers (C-Mix)
28	Naming Your Model	54	Elev-Flap Mixing
29	Exponential	55	Rud-Aileron Mixing
32	Data Copy	55	Rud-Elevator Mixing
34	Switch Reverse	56	Flap-Elevator Mixing
35	Click	56	Spoileron
36	Throttle Cut	57	Aileron Differential
37	RDS8000 Transmitter - Aircraft	58	Landing Differential
38	Aircraft Menu Structure	59	Crow Left Aileron
39	Programming for Aircraft (Model Type)	59	Crow Right Aileron
41	Dual Rate	60	Option Menu Screen
42	End Point Adjustments	61	Trim Step
43	Landing Gear End Points	61	Basic Menu
44	Trim Memory	62	Dual Elevator Mixing
44	3-Position Flap Switch	62	AUX-1 and AUX-2

RDS8000 RADIO CONTROL SYSTEM

SECTION III HELICOPTER

Page

63	RDS8000 Transmitter - Helicopter
9	Airborne System Connections
62	Helicopter Menu Structure
65	Programming for Helicopter (Type)
67	Pitch Curves
70	Throttle Curves
72	Revolution Mixing
73	Gyro Adjustment
74	Trim Memory
29	Exponential
74	Dual Rate
75	Dynamic Trim Memory (DTM)
76	Swash Plate Type (CCPM)
77	Changing Flight Mode 1 and 2 Switch Locations
22	Implementation of Control Function
22	Servo Reversing
23	Control Centering
24	Data Reset
25	Model Selection
26	Stop Watch
27	Integral Timer
28	Naming Your Model
29	Exponential
32	Data Copy
34	Switch Reverse
35	Click
36	Throttle Cut
42	End Point Adjustment
44	Trim Memory
47	Alarms (Throttle High and Flight Mode Only)
52	Compensation Mixers (C-Mix)
60	Option Menu
61	Trim Step
61	Basic Menu

APPENDIX I

78	RDS8000 Aircraft and Helicopter Setup pages
----	---

Thank you for selecting the Airtronics RDS8000 Radio System. In designing the RDS8000 we have made every effort to provide you with a radio that will allow you to extract the maximum performance from your powered aircraft, sailplane, or helicopter, while at the same time simplifying the task of setting up and adjusting your model. These instructions are written in great detail to help you understand all of the RDS8000 capabilities. **Because of the many features of the RDS8000, this manual is quite long. Don't be intimidated!** To actually use the system, you may only need to read the INTRODUCTION section, the Common Functions section, and study the section that applies to your type of aircraft. Each type of aircraft, i.e., fixed wing and helicopter has its own self-contained section describing each applicable feature and its implementation. However, helicopter flyers may find it advantageous to read all sections of the manual to become more acquainted with the operation of the RDS8000 unit. Note that the labels for fixed wing switch functions are in red letters and helicopter switch functions are in Blue letters.

Again, we appreciate your selection of an Airtronics Radio Control System and wish you many hours of flying enjoyment.

2.4 GHz system

This radio controller operates in the 2.4 GHz band. The 2.4 GHz connection is determined by the transmitter and receiver pair, therefore, unlike ordinary crystal systems, the aircraft can be flown without frequency control.

Also, a separate 2.4 GHz receiver can be purchased and paired with the included 2.4 GHz transmitter through a pairing operation.

RDS8000 Transmitter Specifications:

Transmitter Type:	8 Channel, Dual Stick with proprietary Microprocessor
Dimensions:	W: 7.5" X H: 8.0" X D: 2.5"
Weight:	1 lb. 11 oz
Power Output:	90 m Watts
Frequencies:	2.4 GHz
Power Supply:	9.6 Volt, NiCd
Current Drain:	180 MA
Temperature Range:	0 to160 degrees F
Pulse Width:	1.5 ms (nominal)
Model Memory:	10

RDS8000 Receiver Specifications:

Receiver Type:	92824Z 8 Channel, FHSS, "Z" Connectors
Dimensions:	L: 1.85", W: 1.08", H: 0.61"
Weight:	0.53 oz
Receiver Power Supply:	Four Cell, 4.8 Volt

The Academy of Model Aeronautics (AMA) is a national organization representing modelers in the United States. We urge you to examine the benefits of membership, including liability protection in the event of certain injuries. The Academy has adopted simple and sane rules which are especially pertinent for radio controlled flight as the OFFICIAL AMA NATIONAL MODEL AIRCRAFT SAFETY CODE, which we have partially reprinted below:

I will not fly my model aircraft in sanctioned events, airshows or model flying demonstrations until it has been proven to be airworthy by having been previously, successfully flight tested.

I will not fly my model higher than approximately 400 feet within 3 miles of an airport without notifying the airport operator. I will give the right-of-way and avoid flying in the proximity of full-scale aircraft. Where necessary, an observer shall be utilized to supervise flying to avoid having models fly in the proximity of full-scale aircraft. Where established, I will abide by the safety rules for the flying site I use, and I will not willfully and deliberately fly my models in a careless, reckless and/or dangerous manner.

I will have completed a successful radio equipment ground range check before the first flight of a new or repaired model.

I will not fly my model aircraft in the presence of spectators until I become a qualified flyer, unless assisted by and experienced helper.

I will perform my initial turn after take off away from the pit or spectator areas, unless beyond my control.

FCC COMPLIANCE STATEMENT

This equipment has been tested and found to comply with the limits for a Class B digital device, pursuant to Part 15 of the FCC Rules.

These limits are designed to provide reasonable protection against harmful interference in a residential installation. This equipment generates, uses and can radiate radio frequency energy and, if not installed and used in accordance with the instructions, may cause harmful interference to radio communications. However, there is no guarantee that interference will not occur in a particular installation.

If this equipment does cause harmful interference to radio or television reception, which can be determined by turning the equipment off and on, the user is encouraged to try to correct the interference by one or more of the following measures:

Reorient or relocate the receiving antenna.

Increase the separation between the equipment and receiver.

Connect the equipment into an outlet on a circuit different from that to which the receiver is connected.

Consult the dealer or an experienced technician for help.

This device complies with Part 15 of the FCC Rules and with RSS-210 of Industry Canada. Operation is subject to the following two conditions:

1. this device may not cause harmful interference, and

2. this device must accept any interference received, including interference that may cause undesired operation.

Warning: Changes or modifications not expressly approved by the party responsible for compliance could void the user's authority to operate the equipment.

RF Exposure Statement

This transmitter has been tested and meets the FCC RF exposure guidelines when used with the Airtronics accessories supplied or designated for this product, and provided at least 20 cm separation between the antenna and the user's body is maintained. Use of other accessories may not ensure compliance with FCC RF exposure guidelines.

INITIAL PREPARATION

PACKAGING:

The packaging of your Airtronics RDS8000 Radio Control System has been especially designed for the safe transportation and storage of the radio's components. After unpacking your radio, DO NOT DISCARD THE PACKAGING MATERIALS! You should set the packaging aside for use if you ever need to send your radio in for service, or to store your radio in case you do not plan to use it for an extended period of time.

The RDS8000 computer radio control system is designed for the use by power model, sailplane, and helicopter pilots who demand a quality product. The RDS8000 is packed with all of the capabilities that the beginner as well as the more advanced modelers demand for all three types of flying. It has the features available to get the most out of any type of model.

Program Features for all types of models (BASIC turned ON)

10-Model Memory
Stop Watch
Digital Trims
Servo Reversing on all channels
Dual Rate on Elevator and Aileron channels
(Plus Rudder on Helicopter)
Large Liquid Crystal Display (LCD)
End-Point Adjustment on all channels

Model Type selection
Center Adjustment on all channels
Data Reset
LCD Transmitter Voltage Meter
High-Capacity Transmitter NiCd Batteries
Adjustable Stick Tension and Length
Low Battery, High Throttle and Power Alarms

Aircraft Advanced Features (BASIC turned OFF)

All of the features listed under the program with the BASIC turned ON are also included in this Advanced Features section.

Exponential
Trim Memory
Trim Authority (STEP) for digital trims
Model Naming (3 Letters)
Low Battery Alarm
Integral System Timer
Data Copy
Flaperon Mix
Spoileron Mix
Elevon Mix
V-Tail Mix
Throttle Cut
"Click" Audio Tones
Dual Elevator Mix
Aileron Differential

Landing Differential
Crow
Dual Rate Alarm
Menu Options
Flap to Elevator Mix
Throttle to Elevator Mix
Rudder to Aileron Mix
Aileron to Rudder Mix
Rudder to Elevator Mix
Elevator to Flap Mix
Switch Reversing
2 Compensation Mixers
Delta Mix

Helicopter Features (BASIC)

Stop Watch
Servo Reversing
Dual Rate Elev, Ail and Rud
Servo Centering
End Point Adjustment
Throttle Curve (5 Point) in all Flight modes
Revo Mix (3 Point) in all Flight Modes
4 Flight Modes
Gyro Sensitivity Adjustment in all Flight Modes
Pitch Curve (5 Point) in all Flight Modes
Model Select
Model Type
Data Reset
Basic ON

Helicopter Features (Advanced) includes Basic

Exponential
Throttle Cut
Model Naming (3 Letters)
2 Compensation Mixers
Integral System Timer
Trim Step
Switch Reversing
Data Copy
"Click" Audio Tones
Dynamic Trim Memory
Swash Plate Type
Basic OFF
Option Menu

TRANSMITTER FEATURES AND FUNCTIONS

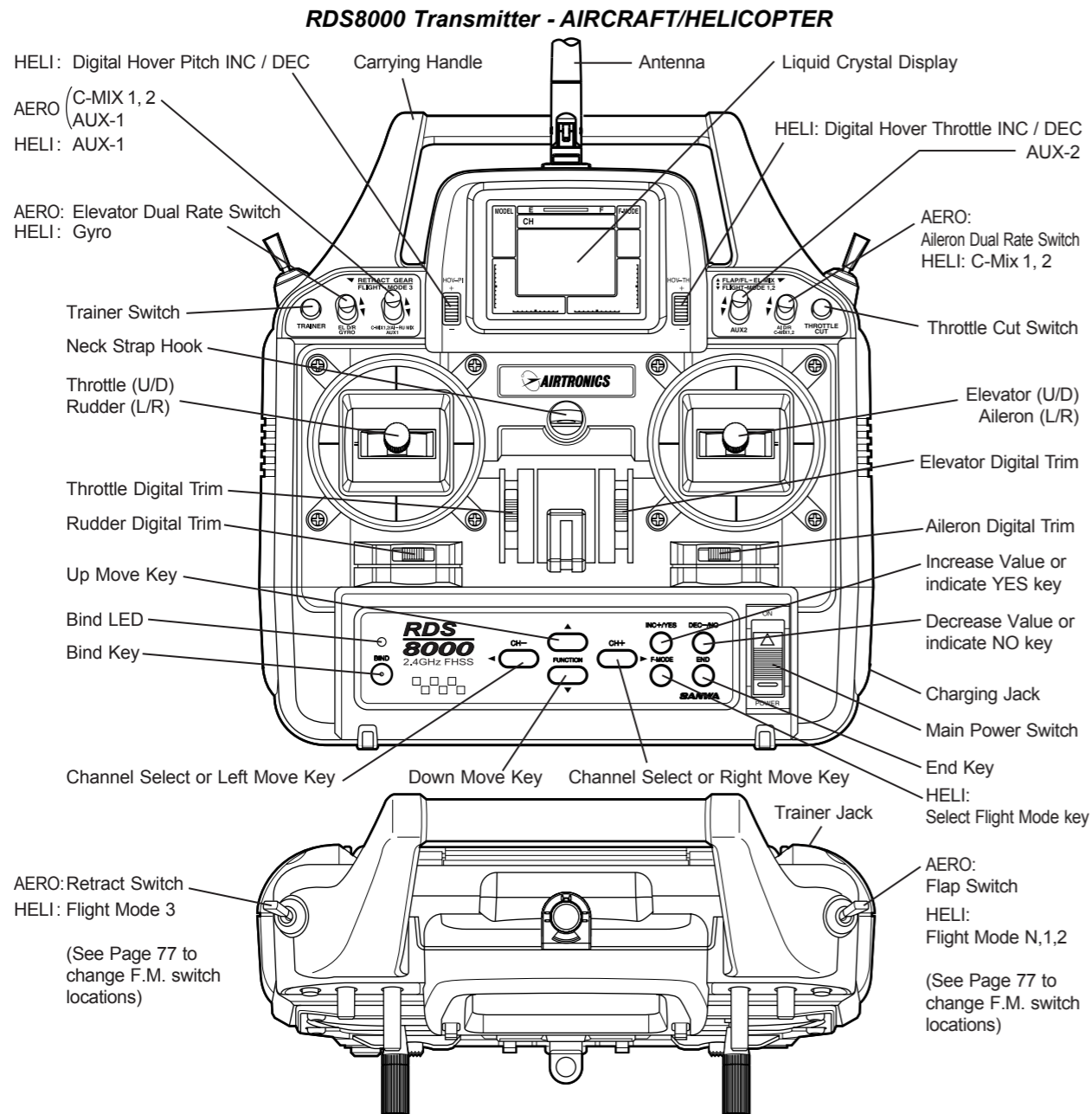

92824Z Receiver Channel Assignments		
Receiver Slot Number	AERO	HELI
1	Elevator	Elevator (F/A) Cyclic
2	Aileron	Aileron (L/R) Cyclic
3	Throttle	Throttle
4	Rudder	Rudder (Tail Rotor)
5	Gear	Gyro
6	Flap or 2nd Aileron Servo	Collective Pitch
7	AUX 1	AUX 1
8/B	AUX 2 / Battery	AUX 2 / Battery

AIRBORNE SYSTEM CONNECTIONS

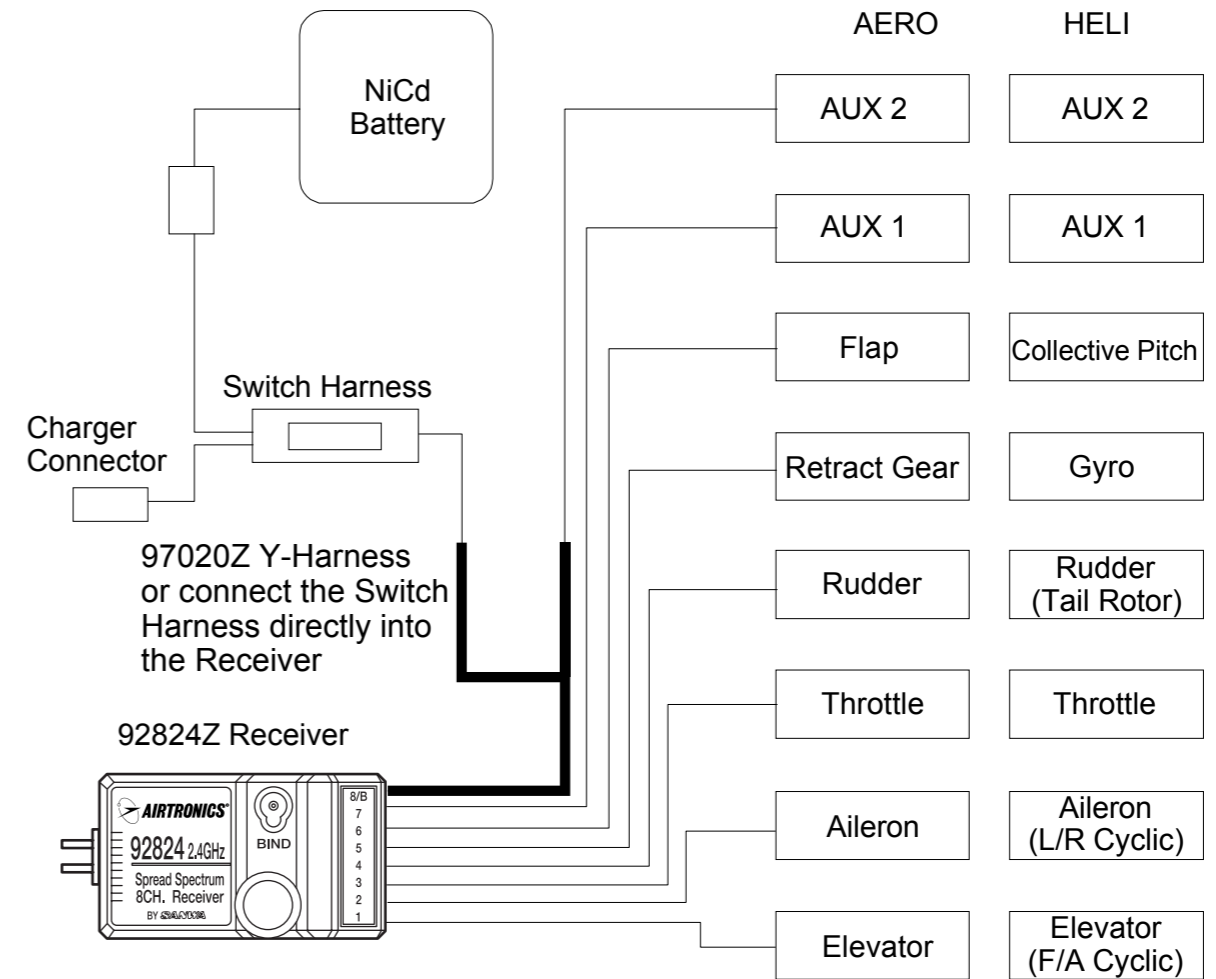

The above diagram shows how to connect the components of your RDS8000 system together. At this point your objective is to get the system operating on your workbench. Once connected you must then refer to the corresponding diagram for your system, i.e., either AERO or HELI showing the transmitter control stick function.

NiCd BATTERY CHARGING INFORMATION:

In order to protect the charging circuit in your RDS8000 transmitter, a diode has been installed to protect it from some of the high discharge rate "cycler's" on the market. We recommend that you charge the transmitter battery (while installed) with the supplied ATX charger, Part # 95033Z.

Should you wish to "cycle" or discharge the transmitter battery, you must first remove it from the transmitter. This allows you to bypass the protective diode.

The following two Airtronics service items will allow you to "cycle" your RDS8000 transmitter battery. See your local dealer for these items.

(1) #99704 Transmitter Charging Plug with Cable for use with your cycling device (black wire w/white tracer is positive).

(1) #97051 Transmitter Battery Cycling Adapter Cable.

Above items will also work with Airtronics Quasar, Radiant, Vanguard, VG Series and all RD Series transmitter batteries.

AIRBORNE COMPONENTS

While your system's batteries are charging, you can familiarize yourself with the airborne portion of your radio. The airborne portion of the radio refers to any components which are mounted in your plane or helicopter and carried aloft when you fly. The airborne components consist of the receiver, which receives the signals from the transmitter, decodes them, and relays the commands to the servos; the servos which are simply electronically controlled motors used to move the surfaces of the plane; the NiCd battery pack which provides power for the receiver and servos to operate; and the switch harness which allows you to turn the airborne package on and off.

CONNECTORS

Your RDS8000 unit is equipped with the newer universal AIRTRONICS "Z" connectors which are color coded blue, and are electrically compatible with the receivers of other radio control system manufacturers. The connectors are rugged but should be handled with care. Note that these connectors are not compatible with older AIRTRONICS R/C equipment unless Adapter p/n 99399Z is used!

"Z" CONNECTOR

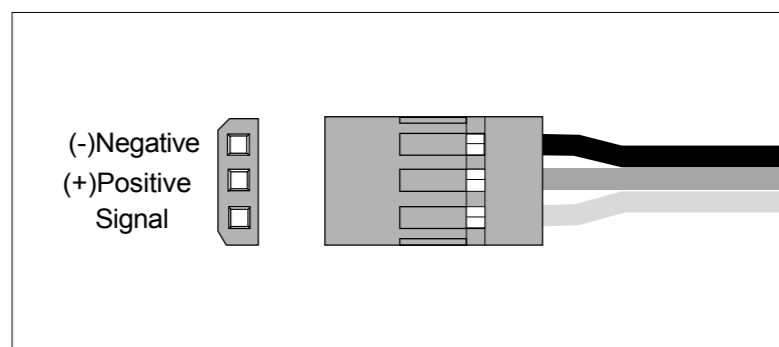

AUDIO LOW VOLTAGE ALARM

Your RDS8000 transmitter is equipped with an Audio Alarm which will sound whenever the transmitter batteries drop below 9.5 volts during transmitter operation. If the alarm sounds while you are flying, land immediately and don't operate the transmitter until it has been charged for 12 hours. The transmitter should normally operate 120 to 150 minutes before the alarm sounds. If the alarm sounds even after the batteries have been on charge for the required time it indicates that there is a problem with either the battery pack or the transmitter, and you should contact AIRTRONICS about service.

TRANSMITTER BATTERY REMOVAL

The NiCd battery in your RDS8000 transmitter can easily be removed and replaced with a fully charged pack to extend operating time. Additional packs are sold separately as an accessory item under the Airtronics part number 95010 (600Mah), 95090 (700Mah) or 95052 (1100Mah) battery packs. To remove the pack, push down on the two ears of the battery door located on the rear of the transmitter. The door can then be removed and the NiCd battery pack can now be removed and unplugged. Reverse the procedure to install a new pack.

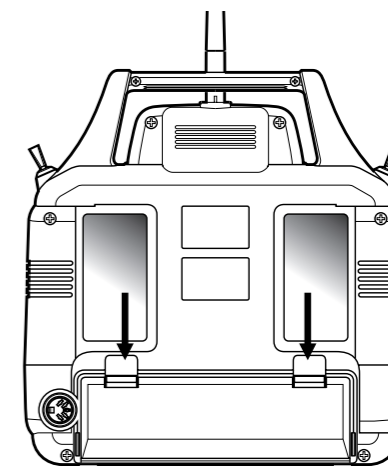
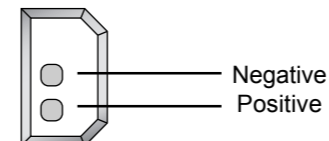

CAUTION:
Observe the correct polarity when plugging in the NiCd battery pack. If incorrect, damage to the transmitter will occur!

THROTTLE HIGH WARNING

The RDS8000 has a built in warning feature that will not allow you to use the transmitter if the throttle stick is not in the lowest position when you turn on the transmitter. If the throttle stick is not in the low position, when you turn it on, you will hear a continuous beeping sound and the display will read TH-HI! Pull the throttle stick down to the full low position. The normal menu will then be displayed and you can operate and/or program the transmitter.

TRANSMITTER STICK LENGTH ADJUSTMENT

The sticks in your RDS8000 transmitter are adjustable in length and spring tension to allow you to tailor their feel to your personal preference. To adjust stick length, hold Part B with your fingers and unscrew Part A counterclockwise to loosen the two pieces. Now screw Part A in or out to the desired position and lock it in place by screwing Part B against it. It is best to leave at least four threads inside Part A when screwed out to its longest length for the best mechanical security. Do not over tighten when you screw the two parts together.

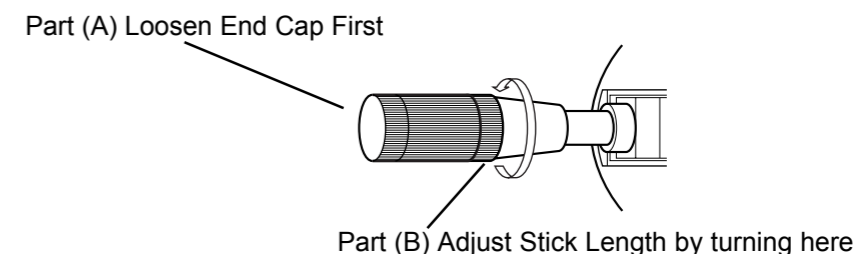

TRANSMITTER STICK TENSION ADJUSTMENT

To adjust the spring tension of the transmitter sticks you need to remove the back of the transmitter case. First remove the antenna and the NiCd battery pack from the transmitter. Now remove the eight screws that hold the case back in place, four in the main case, two in the LCD back cover and two on the handle. Once the screws are removed swing the back of the case away from the transmitter being careful of the trainer plug wiring.

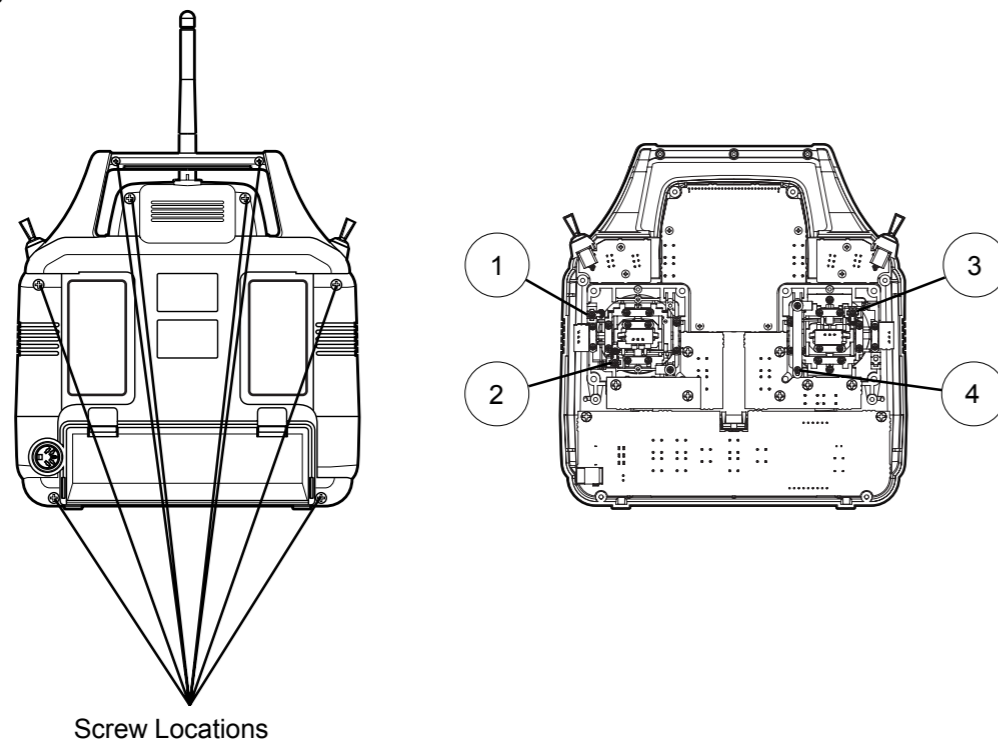

There are four locations for the stick tension adjustment screws installed because the stick controlling the throttle is ratcheted and has no tension adjustment. The #1 and #3 screws adjust the tension for the vertical motion of each stick. The #2 and #4 screws adjust the tension for the horizontal motion of each stick. To make the tension adjustment use a small phillips type screwdriver to turn the adjustment screws. Turning the screw clockwise will increase the stick tension, turning it counterclockwise will decrease the tension. Once you have completed your stick adjustments, replace the case back and install the NiCd battery pack and antenna. Be careful to line the battery charging port pins when replacing the back cover.

WARNING:

Any other modifications made to the transmitter other than adjusting stick tension will void any and all warranties covered by Airtronics Inc.

Precautions on using the 2.4 GHz band

1. The 2.4 GHz band may be used by other devices, or other devices in the immediate area may cause interference on the same band. Always before takeoff, conduct a bench test to make sure the servos operate properly. Also, conduct checks with the transmitter as distant as possible from the aircraft. Safety is best ensured by having an assistant carry the aircraft as far away as possible for checks.
2. Do not fly aircraft in the vicinity of areas in which wireless LANs are being used. Also, do not operate the transmitter anywhere near cell phones or other devices that generate radio waves, etc. This can have adverse effects such as shortening the coverage distance of the aircraft.
3. The response speed of the receiver can be affected if used where multiple 2.4 GHz radio controllers are being used, therefore carefully check the area before takeoff. Also, if response seems slow while flying, land immediately and stop flying.
4. Observe any applicable laws and regulations on fly zones when using the 2.4 GHz radio controller.
5. Unlike frequency bands used with earlier radio controllers, reception with this 2.4 GHz radio controller is adversely affected by large obstructions and concrete or steel structures between the aircraft and transmitter. Also, wire mesh and similar barriers can adversely affect operation. Keep this in mind in order to fly the aircraft safely.

General precautions for use

1. Turn the transmitter ON first and then the receiver to fly the aircraft. When finished flying, turn the receiver OFF first and then the transmitter. It is very dangerous to activate the components in reverse order as the servo may start up inadvertently.
2. Before flying the aircraft, check that the batteries to the transmitter and receiver are sufficiently charged.

Precautions for use: Transmitter

1. Never touch the transmitter antenna while flying the aircraft. Doing so may cause loss of transmitter output, making it impossible to operate the aircraft.
Keep the antenna of the transmitter perpendicular to the ground as best possible.



2. The transmitter's antenna is delicate. Handle with care.
3. Do not press the BIND key while flying the aircraft. The radio signal is interrupted while the BIND and trainer keys are pressed. It may also require time to restore the signal after releasing the keys, which can be dangerous.

Precautions for use: Receiver handling and mounting on aircraft

1. The receiver has 2 antenna wires. The thin section at the tip is the antenna reception wire, therefore mount the antenna to the aircraft without bending the reception wire. Reception performance decreases if the reception wire is bent.

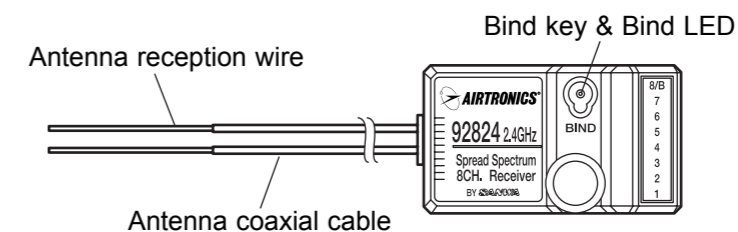

2. The receiver antenna wires are delicate, therefore handle with care. In particular, do not pull on them with force or push them into the case.
3. Do not cut or extend the receiver antenna wires.
4. The thick portion of the receiver's antenna is the coaxial cable. Do not use the unit with this part of the antenna bent acutely. In addition, do not repeatedly bend this part to an acute angle because this can cause the antenna core to break. When mounting on the aircraft, bend it as gently as possible for usage.
5. Mount the receiver antenna wires on a wood or plastic nonconductive part of the aircraft and bend so that the two wires are 90° apart.
 - *This is extremely important in ensuring that the aircraft receives control signals no matter what its posture, attitude or heading.

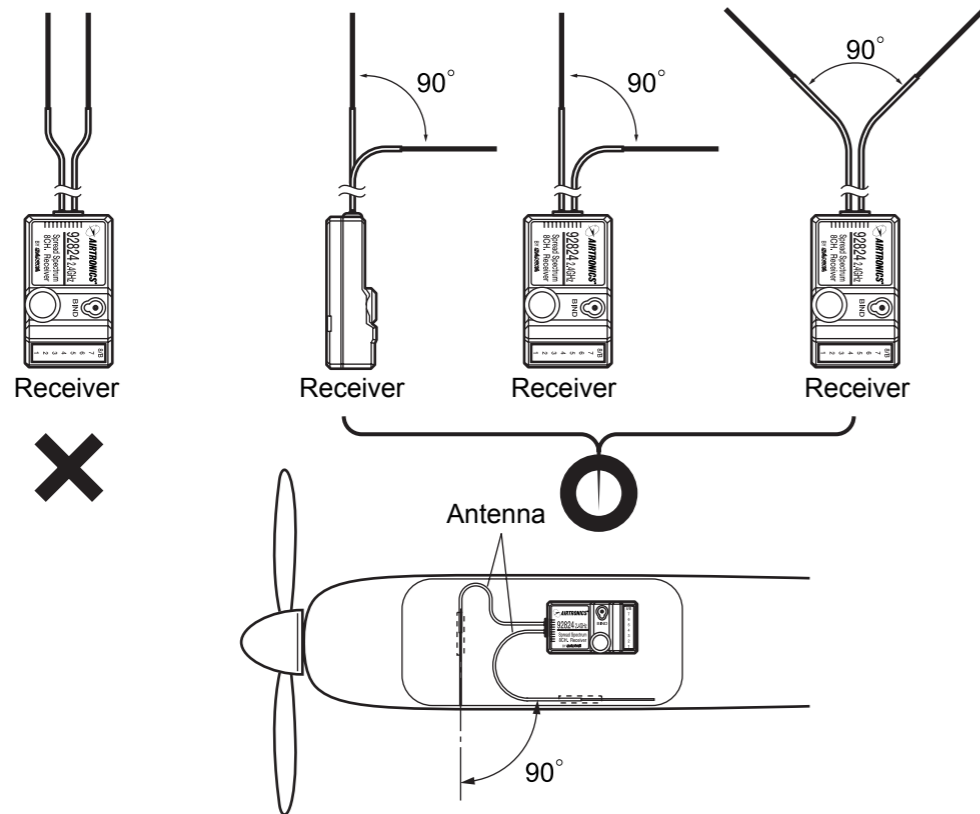

6. Protect the antenna reception wires with a plastic pipe (i.e., antenna pipe for car radio controller, etc.) when mounting the receiver on the aircraft.

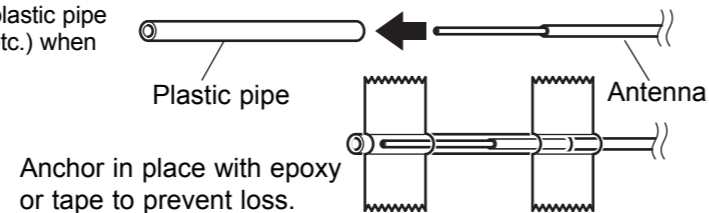

7. Prevent the antenna reception wires from contacting conductive parts when mounting the receiver on the aircraft. Glider bodies and helicopter frames may contain conductive parts, therefore check carefully.
8. If mounting the receiver on an aircraft made of conductive material and the antenna reception wires are surrounded by conductive materials, mount the receiver so that the reception wires extend outside of the aircraft body. Reception can be blocked if the reception wires are shielded.
9. Mount the receiver and antenna so that they are a safe distance from ESCs (Electronic Speed Controller), motors and engines. All such components generate noise and may adversely affect reception.
10. Location of the receiver and antenna reception wires may alter performance. If this happens, try repositioning the receiver and antenna reception wires, ensuring the aforementioned mounting requirements are satisfied. Once having done so, check that the aircraft and servos operate properly before taking off.

TRAINER SYSTEM

The Trainer system in the RDS8000 transmitter allows you to connect any two Airtronics RD series transmitters together for the purpose of training a new pilot. You can also connect the RDS8000 to either VG 400, VG 600, RD6000, RD8000 Radiant or Vanguard PPM unit. The Trainer cord to use is the ATX Part # 97100. **The RDS8000 is NOT compatible with Stylus, Infinity 660 or Quasar units.**

In actual use, one of the two transmitters will serve as the Master and the second transmitter will serve as the Trainer. The Master transmitter is held by the instructing pilot, AND IS THE TRANSMITTER THAT MUST MATCH THE RECEIVER FREQUENCY INSTALLED IN THE MODEL! The trainer transmitter is held by the learning pilot, and does not need to be on the same frequency as the model. The frequency of the Trainer transmitter is unimportant because the switch of the trainer transmitter is NOT turned on during instructional flying. Normally during training, the instructor takes the model off and flies it to a reasonable altitude. While the Master/Trainer switch on the Instructor's transmitter is left in its OFF position, the Master transmitter will have full control of the model. When the instructor is ready to begin training, he presses and holds the spring-loaded switch on his transmitter which transfers control to the student.

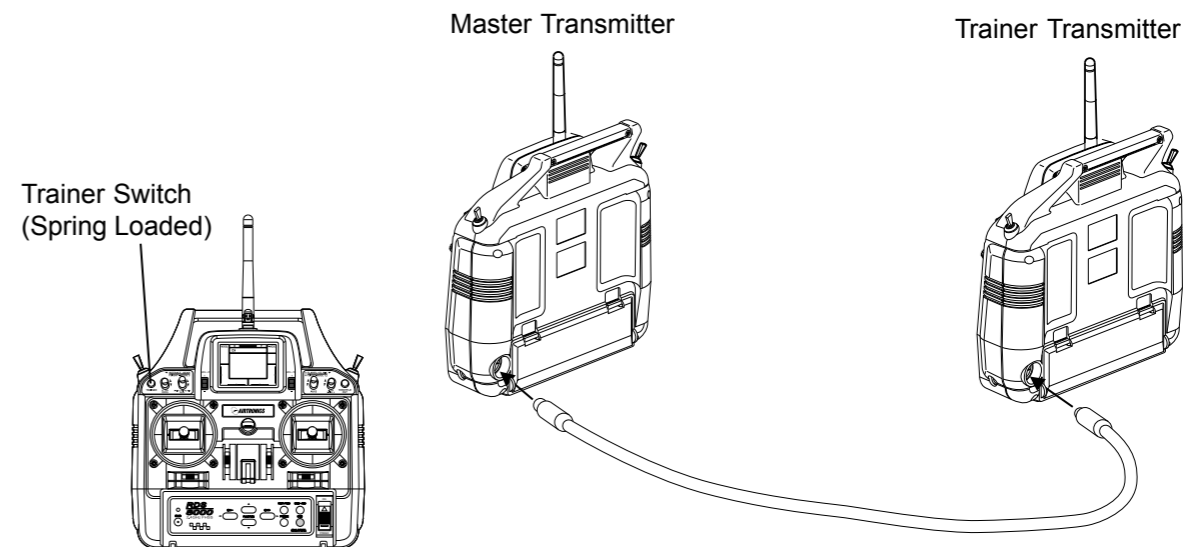

As long as the instructor holds his Trainer switch in the ON position, the model will respond to the commands of the Trainer transmitter sticks allowing the student to fly the model. It is not necessary for the student to hold the trainer switch on the Trainer transmitter.

When the instructor ceases training, or if he feels that the student is in a situation that endangers the model, the instructor can release the spring-loaded switch and control of the model will immediately return to the Master transmitter. To use the Trainer system, you must plug the appropriate Trainer cable into the back of both the Master and the Trainer transmitters. Turn on the Master transmitter and the Model. The cable will energize the encoder section of the Trainer transmitter. Once you have verified that both the Master and the Trainer transmitters will control the model with the spring-loaded switch in the appropriate position you are ready to start training.

To check this, press and release the trainer button on the master radio, while observing the control surfaces and throttle position. Make sure nothing wiggles. Adjust servo direction and trim until nothing wiggles when the button is pressed and released. With the sticks at full deflection (full left aileron, for instance) also press and release the trainer button to ensure that none of the surfaces or throttle wiggles.

NOTE:

Both transmitters must be programmed identically for the trainer system to function properly. All servos must operate in the same direction, centering, end points, and other settings such as type of Modulation must be identical.

USING THE RDS8000 MICROPROCESSOR

Airtronics has invested a large amount of design effort to ensure that the powerful capabilities of the RDS8000 are as simple as possible to use. This manual has been written to offer the user complete instructions for either fixed-wing aircraft or helicopter models. The manual is divided into three sections: Introduction, Aircraft (both powered and sailplane), and Helicopters. You only need to read the introduction section and the one that applies to your type of model. In most cases, all the setup programming is accomplished through the use of the input keys on the RDS8000 transmitter. The function(s) of these are shown below.

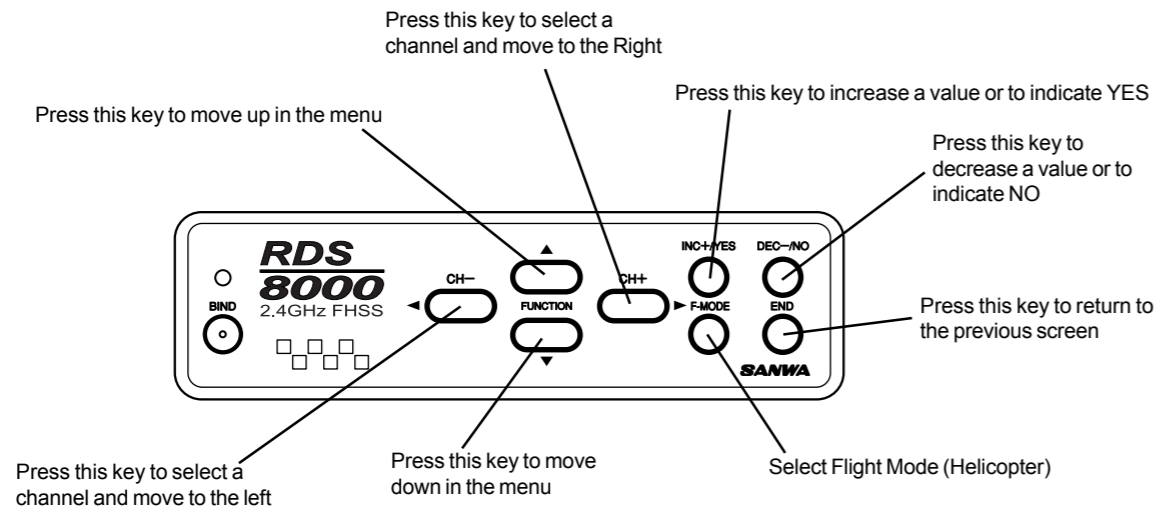

NOTE:

Pressing the INC+/YES and DEC-/NO keys simultaneously will clear a setting and return it to the default value.

Pairing (Binding)

When new, it is necessary to pair the transmitter and receiver to prevent interference with radio controllers operated by other people. This operation is referred to as "pairing" or "Binding". Once paired, the setting is remembered even after power is shut OFF, therefore the operation usually does not have to be redone. However, under some circumstances, the receiver may not operate after turning the transmitter and receiver ON. In such case, perform the pairing operation again.

Pairing the transmitter and receiver

1. Drop the throttle stick of the transmitter to LOW. In HELI mode, turn the flight mode of the Flight Mode switches to Normal (N).

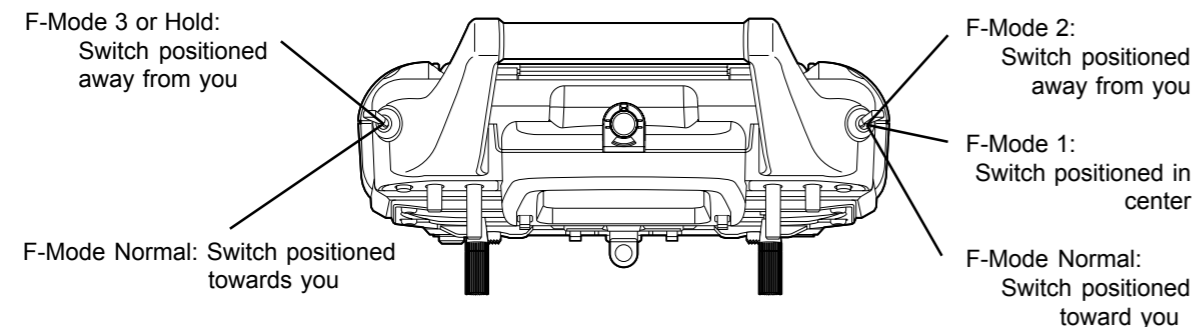

2. Turn ON power to the transmitter. The BIND LED of the transmitter lights.

*If an alarm sounds and the LED does not light, the throttle sticks and Flight Mode switches are incorrectly positioned. Repeat the setting procedure starting from Step 1.

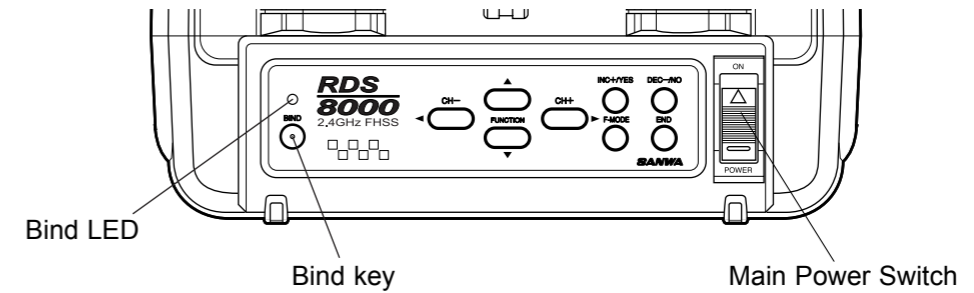

3. While holding down the BIND key on the receiver, turn the receiver ON. The BIND LED will flash slowly. When the BIND LED flashes slowly, let go of the receiver's BIND key.

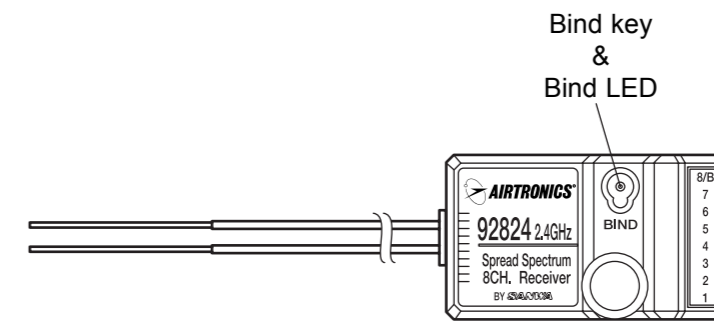

4. While the BIND LED on the receiver is flashing slowly, press the BIND key on the transmitter. The BIND LED on the receiver starts flashing rapidly and soon after lights solidly. This indicates that pairing was successful.

*Unless the BIND key on the transmitter is pressed within 10 seconds, the BIND LED on the receiver will automatically time out and stop flashing. If this occurs, you simply need to repeat steps 3 and 4.

Failsafe

Failsafe sets the servo to a predetermined position in the event the signal from the transmitter is interrupted for some reason and the aircraft cannot be controlled.

Set failsafe to a position that is conceivably safe should control be lost during flight, such as to drop the throttle to LOW.

Failsafe is not factory-set and, the servo is free (not powered) if the signal is interrupted.

To clear your programmed failsafe settings and restore the factory defaults, pair the transmitter and receiver once more.

IMPORTANT NOTE:

Pairing the transmitter and receiver clears your failsafe settings! So, only re-pair if necessary and then remember to re-establish your desired failsafe settings.

*When the signal is restored, normal control returns.

Setting is available only for CH1 through CH4. (CH5 through CH8 cannot be set.) Also, the failsafe setting is applied to all settings in a given channel; channel settings cannot be individually set.

Setting the failsafe

1. Drop the throttle sticks of the transmitter to LOW. When using in HELI mode, turn the flight mode of the Flight Mode switches to Normal (N).
2. Turn the transmitter power ON. The BIND LED of the transmitter lights up.
 - *If an alarm sounds and the LED does not light, the throttle sticks and Flight Mode switches are incorrectly positioned. Repeat the setting procedure starting from Step 1.
3. Turn the receiver power ON. The LEDs of the transmitter and receiver light up. At this point, try moving the transmitter's sticks to see if the servo is operating. If it does not appear to be operating, repeat the BIND procedure.
4. Move the transmitter sticks to the desired failsafe position. While holding the sticks in those positions, press and hold the BIND key of the receiver. Soon after, the BIND LEDs of the receiver start flashing slowly, then flash rapidly and ultimately stay lit. This indicates that the failsafe was set successfully.
 - *Press and hold the BIND key of the receiver until the receiver's BIND LEDs stay lit.
5. Turn the transmitter power switch OFF to interrupt the transmission signal and check whether the servos have come into the set position. This check is for safety purposes, therefore perform before takeoff.
 - *To change failsafe settings, repeat steps 1-4.

Range Check Mode

The controller has a Range Check Mode function, which lowers the transmitter's output level to check radio signal reception. Use this function to check radio signal reception on the ground, prior to flight. To check reception, put the controller in Range Check Mode, walk about 30 paces away from the aircraft, and check to make sure the servo moves without problem.

How to transmit to Range Check Mode and check range

1. Drop the throttle sticks of the transmitter to the end of the low side. When using in HELI mode, turn the flight mode of the Flight Mode switches to Normal (N).
2. While pressing the transmitter's BIND key, turn the transmitter power ON.
 - *If you hear a warning signal, correct the positions of the throttle sticks and Flight Mode switches, and repeat the setting procedure starting with Step 1.

3. The transmitters BIND LED will blink steadily. Continue holding the BIND button in for approximately 5 seconds until the LED goes out and then let go of the BIND button. If the LED then resumes a steady blinking, the transition to Range Check Mode was successful.
 4. Immediately turn the receiver ON, walk about 30 paces from the aircraft (approximately 90 feet) and, with help from another person, check to make sure the servos move without problem.
 - If there is a problem with servos movement, try moving while maintaining the same distance from the aircraft, and check again to make sure the servos moves without problem.
 - If there is still a problem with servos movement, check to make sure there are no problems with servos connector connections and so on. Do not fly the aircraft until you have solved the problem.
 - * Range Check Mode automatically turns off in about 3 minutes, and the system changes to Normal Mode.
 - Be sure to check servos movement while checking that the transmitter's LED is blinking. If the LED has changed to constantly lit status while checking servos movement, turn the transmitter power OFF. Repeat the process from step 1, then go into Range Check Mode.
 - * In this case, it is not necessary to turn the receiver OFF.
- * Caution! Do not fly the aircraft while in Range Check Mode. You will be unable to control the aircraft once it has flown a certain distance.

Mode	Transmitter LED status
Range Check Mode (Low transmission output)	Steadily blinking
Normal Mode (Normal transmission output)	Constantly lit up

BAR GRAPH VOLTAGE INDICATOR

As a convenience, the RDS8000 transmitter provides a transmitter battery Bar Graph voltage indicator at the top of the Liquid Crystal Display labeled "E" and "F". The "F" symbol indicates FULL and the "E" indicates EMPTY. You can consider it similar to a gas gauge. The Bar Graph indicator is in addition to the normal battery voltage that is displayed on the main screen when you select AERO or HELI by pushing the END key twice. When the Bar Graph reads less than half you should not fly until you recharge the transmitter. (9.2V.)

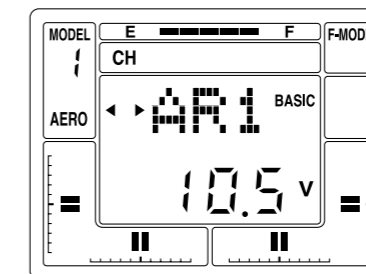

RDS8000 AERO FEATURES

FEATURES	DESCRIPTION
STW (Stopwatch)	Used as a stopwatch or to countdown to a preset time.
REV (Reverse)	Reverses the servo operating direction.
D/R (Dual Rate)	Adjusts servo throw. Available on Elev and Ail.
CNT (Center)	Changes servo neutral position.
TRM (Trim)	The LCD provides an indicator of the value, as well as the direction of the trim.
EXP (Exponential)	Changes the linear movement of the servo to the relation of the stick movement. Can be set Positive or Negative.
EPA (End Point Adjustment)	Limits the total movement of a servo in each direction.
M-SL (Model Select)	Select models 1 to 10.
TYP (Type of Model)	Model Type Aircraft or Helicopter.
INT (Integral Timer)	Used to show how long the transmitter has been in use. Can be reset to zero.
RST (Reset)	Clears all setup data in any model to factory default settings.
CLK (Click)	A beep sound can be heard every time you press a transmitter key. Options Active or Inoperative.
NAM (Name)	You can use up to 3 characters to name your model.
SW-R (Switch Reverse)	You can reverse the default direction of all control switches.
CPY (Copy)	Copy one model to another.
FLAPE (Flaperons)	Activates 2 channels to be used for Ailerons.
DELTA (Elevons)	Ailerons operate as ailerons and as well as Elevators. Used for flying wings.
V-TAIL (Rudder and Elevator)	Used for V-Tail models.
D/R-A (Dual Rate Alarm)	Alerts you when a Dual Rate switch is on. Options On or Off.

FEATURES	DESCRIPTION
T-CUT (Throttle Cut)	You can set the point where the throttle can be cut using the throttle cut-off button.
C-MIX (Compensation Mixing)	Ability to mix a master channel to another slave channel with a C-Mix Switch.
E>F (Elevator to Flap Mixing)	Ability to mix Elevator to Flap.
R>A (Rudder to Aileron Mixing)	Ability to mix Rudder to Ailerons.
R>E (Ruder to Elevator Mixing)	Ability to mix Ruder to Elevator.
F>E (Flap to Elevator Mixing)	Ability to mix Flap to Elevator.
SPOIR (Spoilers)	For sailplanes. Both ailerons will act as spoilers as the throttle stick is used.
AI-DIF (Aileron Differential)	Changes the total amount of throw up and down to both aileron servos independently to help stop any adverse yaw.
L-DIF (Landing Differential)	Allows Aileron control to remain effective when Crow or Spoilers are used (Sailplane).
CR:LA (Crow Left Aileron) CR:RA (Crow Right Aileron)	Crow is used to slow the sailplane down. Ailerons go up when flaps go down. Left and Right Ailerons are adjustable.
OPT (Option Menu)	Advanced program allows you to turn off or on function displays.
Step (Trim Step)	Sets the amount of movement a servo will move with one beep of the trim.
BASIC (ON/OFF)	Turn Basic menu on or off.
D-EL (DUAL ELEVATOR)	Activates 2 channels to be used for dual elevator servos. Ch 1 left servo Ch 7 Right servo

RDS8000 HELI FEATURES

FEATURES	DESCRIPTION
STW (Stopwatch)	Used as a stopwatch or to countdown to a preset time.
REV (Reverse)	Reverses the servo operating direction.
D/R (Dual Rate)	Adjusts servo throw. On Elev, Ail and (Rud in HELI Mode) Used to provide a switchable high and low servo throw. This can be used to provide more surface movement for 3D aerobatics, and lower amount for precision flight, for example.
CNT (Center)	Changes servo neutral position.
TRM (Trim)	The LCD provides an indicator of the value, as well as the direction of the trim.
EXP (Exponential)	Changes the linear movement of the servo to the relation of the stick movement. Can be set Positive or Negative.
EPA (End Point Adjustment)	Limits the total movement of a servo in each direction.
M-SL (Model Select)	Select models 1 to 10.
TYP (Type of Model)	Model Type Aircraft or Helicopter.
INT (Integral Timer)	Used to show how long the transmitter has been in use. Can be reset to zero.
RST (Reset)	Clears all setup data in any model to factory default settings.
CLK (Click)	A beep sound can be heard every time you press a transmitter key. Options Active or Inoperative.
NAM (Name)	You can use up to 3 characters to name your model.
SW-R (Switch Reverse)	You can reverse the default direction of all control switches.
CPY (Copy)	Copy one model to another.
T-CUT (Throttle Cut)	You can set the point where the throttle can be cut using the throttle cut off button.
DTM (Dynamic Trim Memory)	Memorizes trims in each flight mode.
GYR (Gyro)	Gyro sensitivity for each flight mode.
CV-P# (Throttle Curve)	To setup a curve in all flight modes.
CV-P# (Pitch Curve)	To setup a curve in all flight modes.
RV (Revolution Mixing)	Tail rotor offset mixing.
C-MIX (Compensation Mixing)	Ability to mix a master channel to another slave channel with a C-MIX switch.
STEP (Trim Step)	Sets the amount of movement a servo will move with one beep of the trim.
SWH (Cyclic Type)	5 Cyclic Options (Normal, CP3F, CP3B, CP4F, CP4B).
BASIC (ON/OFF)	Basic menu ON or Off.
OPT (Option Menu)	Advanced program allows you to turn off or on function displays.

SECTION II COMMON FUNCTIONS

The following functions are common and applicable to both Aircraft and Helicopter programming. The Liquid Crystal Display shows an AERO model selected. However, a similar screen will be displayed when a Helicopter type model is selected.

NOTE: Switches labeled with red lettering are for aircraft and blue lettering is used for helicopter.

IMPLEMENTATION OF CONTROL FUNCTIONS

In this section you will learn how to implement the control functions and tailor the servo movement and centering for each control. Pressing the END key on the front panel several times will bring you to the following screen, i.e., the initial screen that indicates the current model type and number, and the transmitter NiCd battery pack voltage.

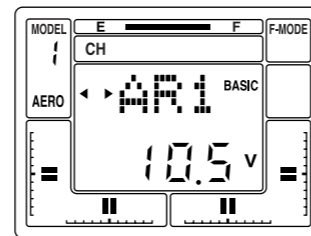
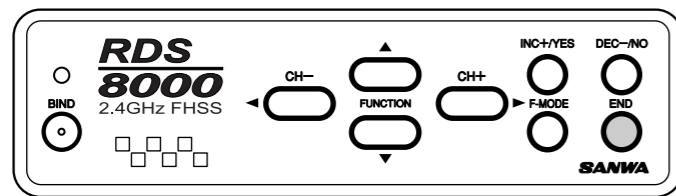

Press the (CH +) key to obtain the STW screen. The Elevator channel will appear on the upper part of the screen. The model number and AERO will be present on the left side and the stop watch will indicate zero since no time has been programmed.

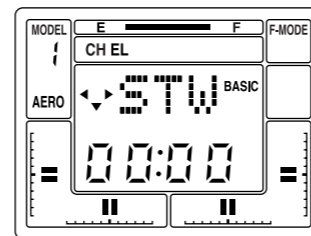
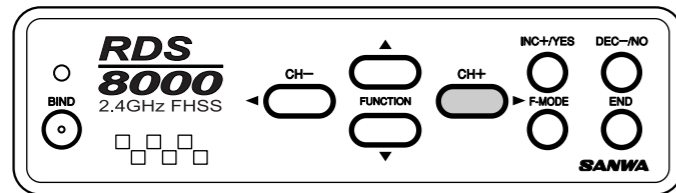

REV (SERVO REVERSING)

The RDS8000 allows you to electronically REVERSE the direction of rotation for each of the servos in use. This allows you to hook up your control linkages and pushrods in the most mechanical desirable manner without regard to the direction of servo movement. After installing your linkages, check to see if any of the servos move in the wrong direction when you move the controls. If so proceed as follows for reversing the elevator channel. Reverse for all other channels is done the same way.

Press the FUNCTION down key to arrive at the following screen:

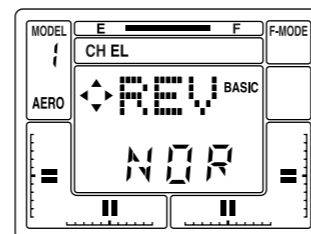
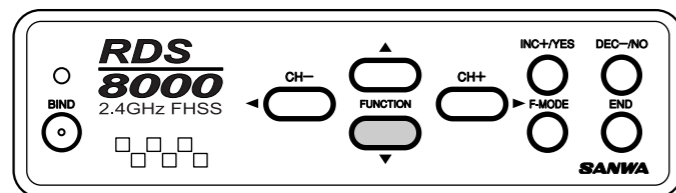

Move the control stick for the elevator function. If the Elevator servo moves in the wrong direction, press the INC +/YES key to change the direction. Move the cursor to the channel whose direction you wish to change (one of the following: EL, AL, TH, RU, G, P/F, 7 or 8) and set REV function.

CNT (CONTROL CENTERING)

Your RDS8000 allows you to fine-tune the CENTER or neutral position of the servos. After hooking up your controls and mechanically centering all linkages to the approximate positions, press the FUNCTION down key to arrive at the following screen for the Elevator control.

(Note that the Aileron, Throttle, Rudder, Flap, AUX-1 and AUX-2 centering operates in the same manner when you select that channel on the upper part of the screen. You can move across to the CNT function of each channel as well as some of the other functions by pressing the (CH+) key.

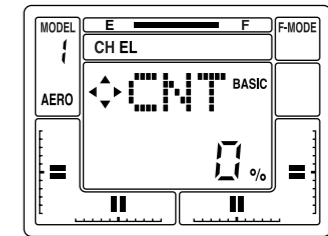
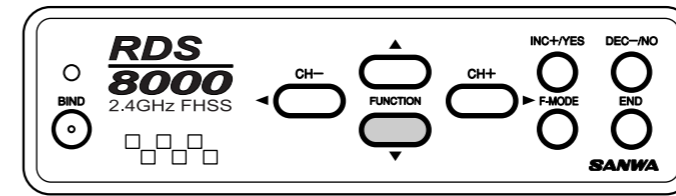

By pressing the INC+/YES or DEC-/NO keys you can vary the value from 0 to + or - 100%. Default is 0%.

IMPORTANT NOTE:

It is desirable to adjust the control linkages as close as possible to the correct center positions, then use the CNT (CENTER) commands to "Fine-tune" the exact position of the control surface when the transmitter control is in neutral.

Using a large amount of electronic centering adjustments will decrease the total throw available for that channel. In particular, centering adjustments greater than + or - 50% will tend to make the extreme stick position on one end less responsive!

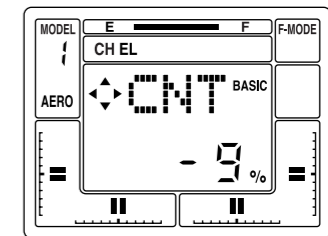
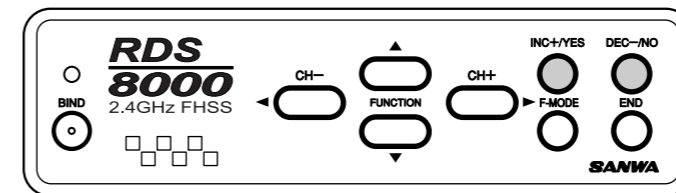

RST (DATA RESET)

If you want to "UNDO" all of your programmed parameters at one time, you can use the RST function. However, be certain that is what you want to do, since this function will reset all settings to the factory default settings. The RST function will only affect the specific model that you have selected. All other models in memory are unaffected by the RST function.

Press the END key to select the initial AR 1 screen that indicates the Transmitter NiCd pack battery voltage. Now, press the CH + to access the STW (Stopwatch) screen. This screen allows you to move up and down as well as left and right on the screen in the RDS8000 program.

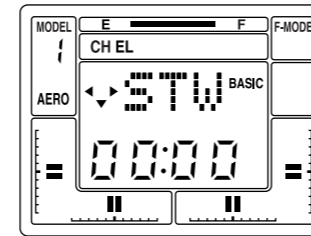
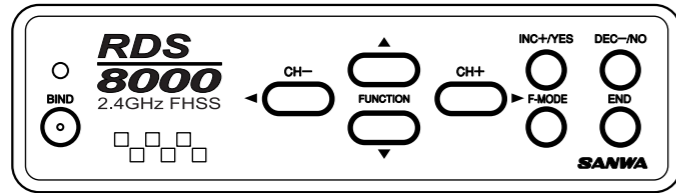
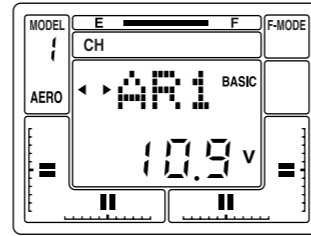
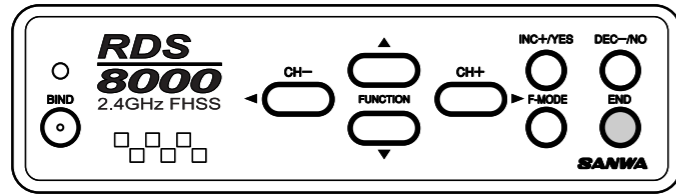

Press the CH + key several times to move across the CH indicator portion of the screen until it reads "etc". Now, press the FUNCTION down key three times to move down in the menu until you reach the RST (Data Reset) screen.

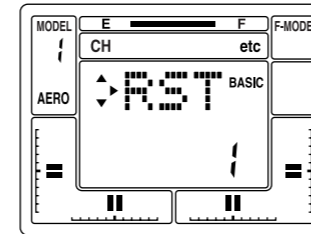
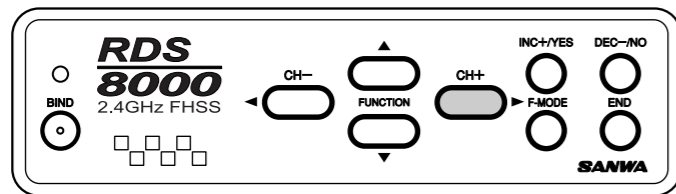

First, press the INC+/YES or DEC-/NO key to select the model you would like to reset. To reset all data for this model to default settings press the (CH +) key and the screen will flash YES. Now, press the INC +/YES key and the screen will indicate OK! All parameters on this specific model number have now been reset to default values. Press the END key twice to return to the STW screen.

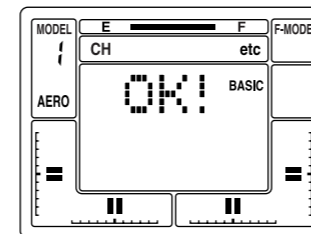
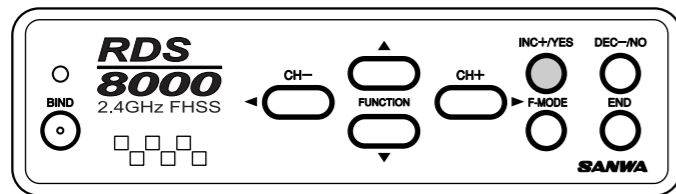

HOW TO SELECT MODEL SET-UPS: M-SL (Model Select)

The RDS8000 has built in memory to store ten model setups in any combination of model types. To use or modify one of the model setups you first must select M-SL in the "etc" menu. Assume that you want to select a second model. To do so, press the END key to bring up the initial screen that indicates transmitter voltage and model number.

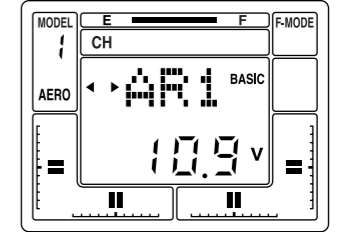
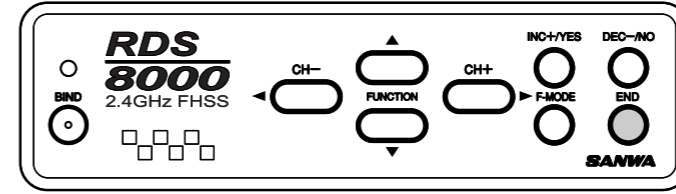

Press the (CH +) key to scroll to "etc". Use the FUNCTION down key to select MSL. Next press the INC +/YES key and the screen will flash MSL to indicate you can select a second model. Press the INC +/YES key again to select the next or following model such as AR2.

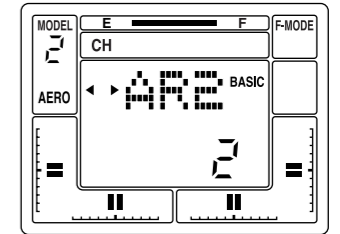
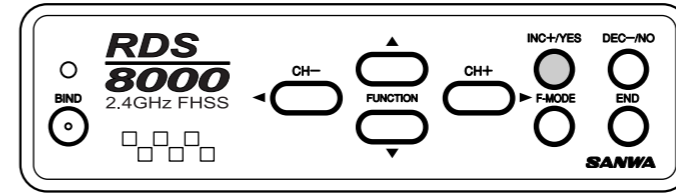

Press the END key three times to return to the initial screen which will show the model number and the transmitter battery voltage reading.

NOTE: if the model type is incorrect, i.e., HELI rather than AERO, continue with the model selection procedure. The model type can then be selected on the TYP screen.

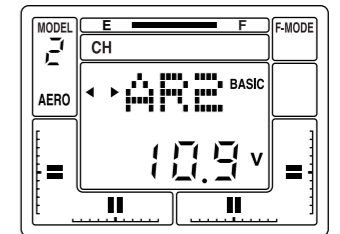
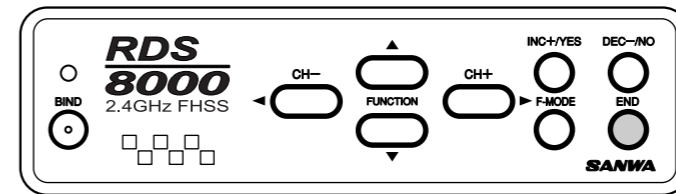

TYP (MODEL TYPE)

To select the type of model you wish to program, press the (CH+) key to scroll to "etc". Next press the FUNCTION key to select TYP. Now press the (CH+) key to select the next model type, either HELI or AERO. The screen will flash YES with the type of model indicated on the LCD display. To confirm your selection, press the INC+/YES key and the screen will indicate OK!

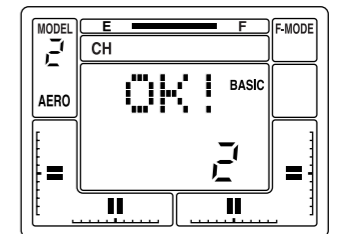
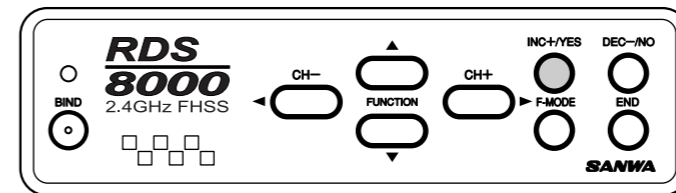

Press the END key three times to return to the initial screen that will then show your model number/type and transmitter battery voltage.

STW (STOPWATCH)

The RDS8000 offers a built-in timer and allows the pilot to use the stopwatch function in either elapsed time or countdown mode.

NOTE: To program a time, you must be in the BASIC OFF mode of operation. To use the stopwatch, press either the (CH -) or the (CH +) key to select "etc" on the Channel indicator display.

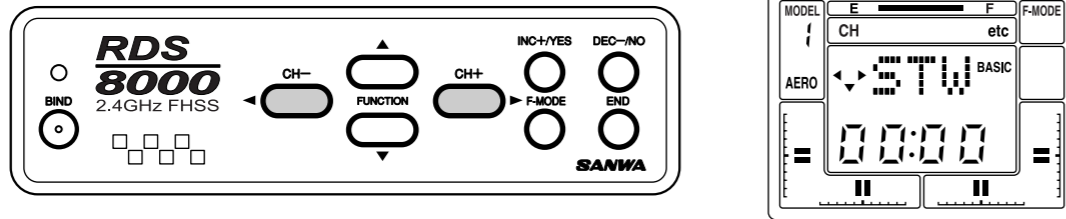

Now press the FUNCTION down key to scroll through the screens until you find the STW screen with the flashing indicator. This is where you set your stopwatch countdown time. The STW (set) screen is just above the INT screen as shown on the Menu Structure, page 38.

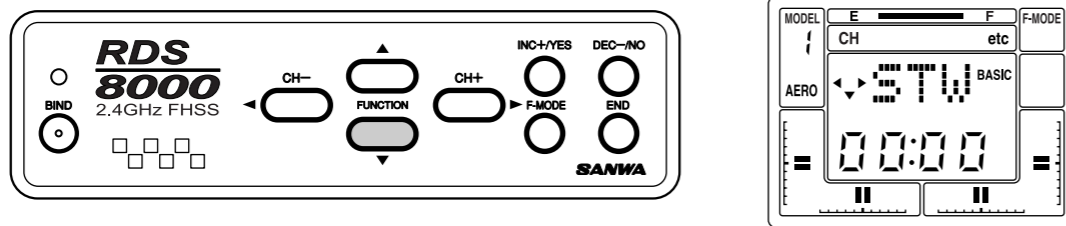

Use the INC +/YES key to set a value for the start of your count down. As an example set it at 10.00 minutes. The screen will look like the following illustration. If you want to decrease the time, use the DEC - /NO key. If you want to clear the time, press the INC +/YES and the DEC - /NO keys simultaneously.

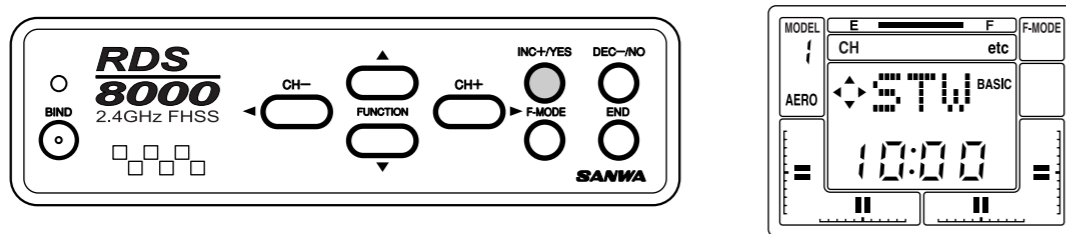

You can now start the stopwatch from any channel-indicator screen that displays the STW screen and the programmed time. Press the INC+/YES key to start or stop the countdown. When the time reaches 10 seconds, a tone will be heard every second as it counts down to zero. When the timer reaches zero, a steady tone will be heard and it will start counting up. Press the INC+/YES key and DEC-/NO key simultaneously to reset the timer to your previously-programmed time.

INT (INTEGRAL TIMER)

The Integral Timer function of the RDS8000 is activated each time the transmitter power switch is turned on, and counts up to 99 hours and 59 seconds at all times when the transmitter is turned on. This indicates how many hours of actual use you RDS8000 transmitter has operated. You may reset the timer to zero at certain intervals, for instance, each time you charge the transmitter NiCd battery pack.

The INT (Integral Timer) function is located in the "etc" column of the menu, directly below STW (set). Use the FUNCTION down key to access the INT screen. Note that it will have some indication of how long the transmitter has been operating. It may look like the following screen, but with a different time shown. The time will show a change for each elapsed second and minute. If you want to reset the Integral Timer to Zero, press the INC +/YES and the DEC -/NO keys simultaneously.

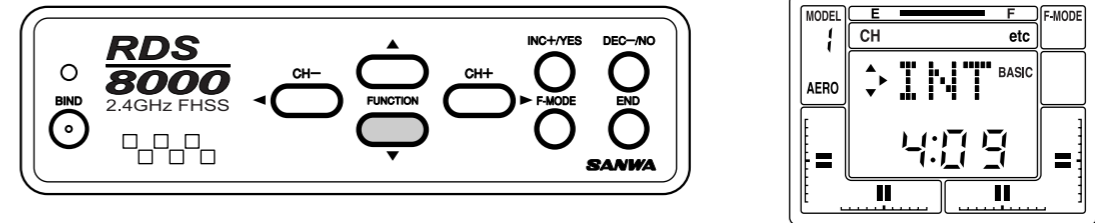

You can display the Integral Timer function instead of the STW (stop watch) function on all Channel screens. While you are in the INT screen, press the (CH +) key to obtain the following screen.

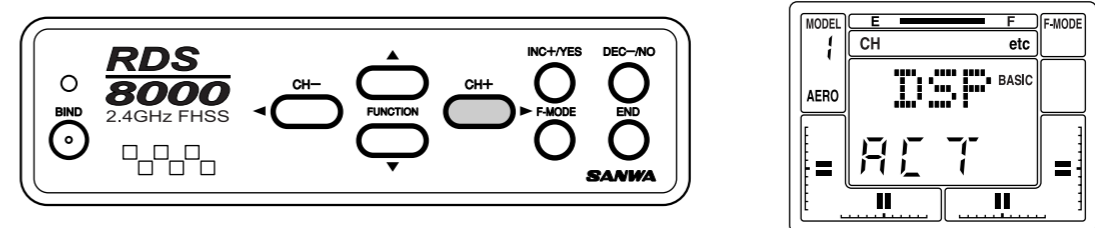

Press the INC +/YES key and the bottom line of the screen will change from INH (inhibit) to read ACT (active). You can press either the DEC -/NO key or the INC +/YES key to change it back to INH. Most pilots prefer to have the Stopwatch function displayed on all Channel screens, rather than the Integral Timer, therefore, they leave the Integral Timer DSP at INH (inhibit). Press the END key twice to get back to the top of the "etc" menu column.

NAM (NAMING YOUR MODEL)

The RDS8000 provides the capability to designate each of the 10 models you have programmed by use of a 3 digit name. Use the (CH +) key to select the “etc” screen. Press the FUNCTION down key twice to select the NAM screen.

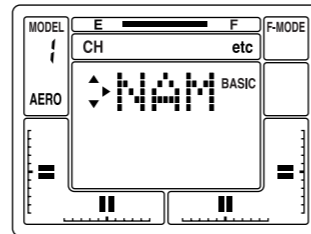
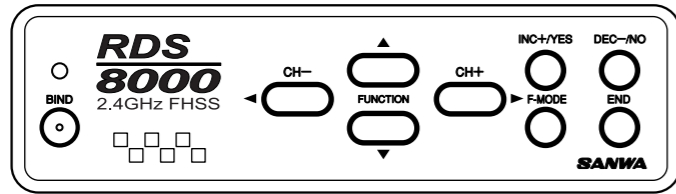

Now press the (CH +) key to select the screen for model number one. The first character will flash to indicate you can change that letter.

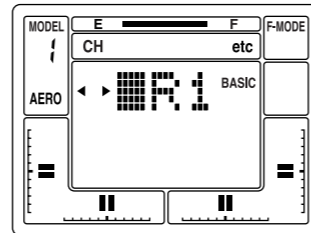
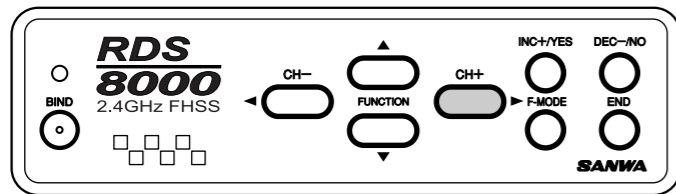

Press the INC +/YES key to scroll through the letters of the alphabet and make a change in the first letter. You may use any combination of LETTERS (upper and lower case), NUMBERS, Colon (:), Dash (-), Character, or blank space to designate a model. When you have finished the first letter or number, press the (CH +) key to move to the next letter and set it in a similar manner. The DEC -/NO key can also be used to change a letter or number in the opposite direction. Press both the INC + /YES and DEC -/NO keys simultaneously to return to the default setting of AR 1. Once you have named the model, press the END key twice to return to the “etc” column heading.

EXP (EXPONENTIAL)

The RDS8000 allows the pilot to choose two settings for Exponential throw for each of Elevator, Aileron (and Rudder in helicopter mode).

Exponential throw is primarily used to “soften” or decrease the sensitivity of a control stick around the neutral point. With Exponential disabled, a servo will move in proportion to the amount of control stick deflection, i.e., 50% stick deflection will result in 50% servo travel; 75% stick deflection will result in 75% servo travel.

Exponential settings DO NOT change the amount of travel available at 100% stick deflection, but rather it changes the amount of the servo travel at stick deflections less than 100%. The first 25% of stick deflection may be set to result in only 10% of total servo, throw making the control less sensitive around neutral. See the following illustrations.

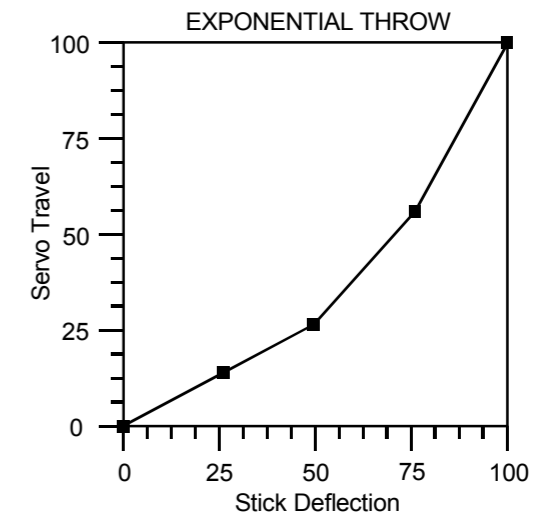
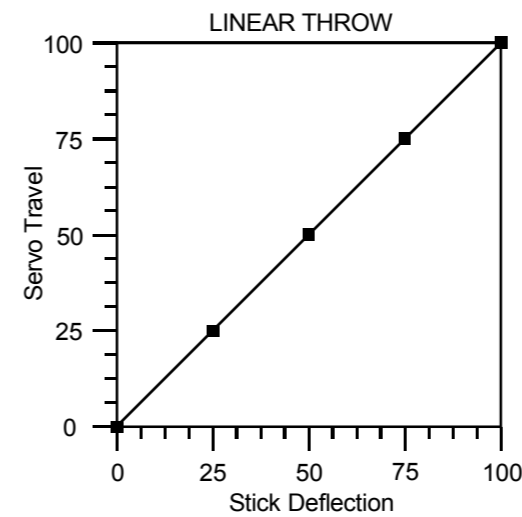

If you have not used Exponential functions before, you will want to start with a small amount of Exponential (10 to 20%) to determine whether you like this sort of control response. Exponential is most useful where strong control response is desired at extreme stick positions but softer response to small stick movement is desired in order to make very accurate small corrections to the flight path.

The switch positions for Exponential #1 and Exponential #2 correspond to the Dual Rate switch positions of Elevator and Aileron. Exponential #1 is with the Dual Rate switch in the down i., (Off) position. Exponential #2 is with the Dual Rate switch UP (ON) position. (Note however that you can leave the Dual Rate adjustments for Elevator and Aileron set at 100% which is no rate, so that switching a Dual Rate switch ON will activate Exponential only.

NOTE: Setting the Exponential with a positive number will make servo movement soft in the neutral area of the stick movement. Setting the Exponential with a negative number will make servo movement faster in the neutral area and softer at the end of the stick travel.

As an example, to set Exponential for elevator, access "EL" in the Channel area by using the (CH+) key.

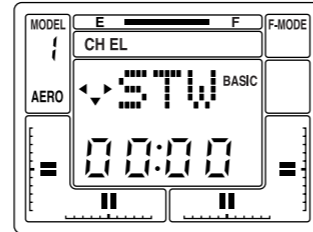
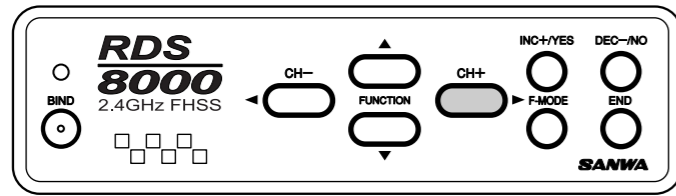

Now press the FUNCTION down key to select the EXP display for the Elevator Channel as shown below.

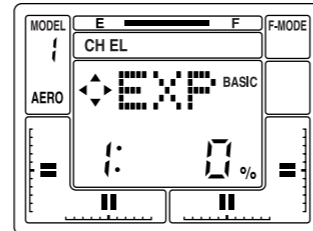
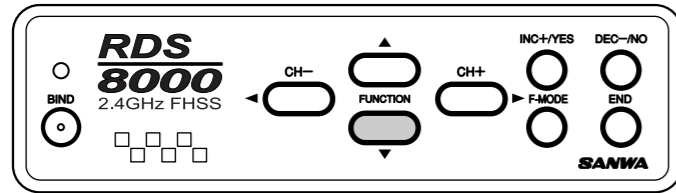

This screen shows you the present Exponential status of the elevator channel and when a Dual Rate Exponential switch is set to ON position, the Exponential setting for that control function. The possible range for Exponential settings is from -100% to +100%. Note that 0% is linear. A negative value will speed up the response and it will make the stick movement more sensitive around the neutral position.

To set an Exponential rate in this example, turn the Dual Rate switch for Elevator to the ON upward position. Note that the display changes to Exponential #2. You can set the value for the Elevator channel Exponential. Press the INC+/Yes key to set a positive value of Exponential function as indicated below.

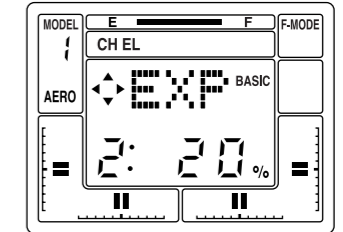
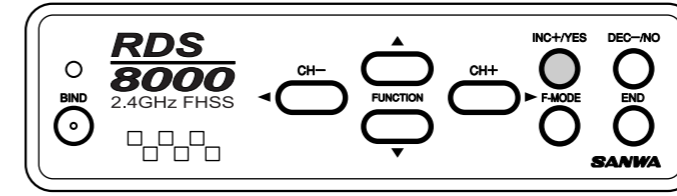

In the above example, we set Exponential #2 to be 20% of the maximum for the Elevator channel. This is a good starting point for determining the suitability of Exponential throw for your aircraft and flying style.

You can actually have two different Exponential settings if you desire. One for switch position #1 and another for switch position #2. However, when you first start using Exponential throw, it is usually best to leave the switch #1 position at 0% which is linear throw.

In general, large amounts of Exponential are useful only where very large control-surface deflection is required at extreme throw, while very small amounts of control response are necessary for smaller control stick inputs. One example where large Exponential settings may be useful is the highly maneuverable "Competition FUN FLY" style model. For most sport and aerobatic models, an Exponential setting from +10% to +25% will give the desired "softness" around neutral.

CAUTION: Proceed with care when setting Exponential functions to ensure that you will have adequate control deflection available in any possible switch position. Setting Exponential to a very high or 100% setting will require very large stick movements to achieve small control responses. Always make sure that you are aware of the present status of any rate assignments that you have selected! For the most flexibility in setting up an aircraft model to your liking, study the available options for Dual Rates, End Point Adjustments, and Exponential. The combinations of these options allows several possible set-ups. The Exponential for the Aileron Channel is set in the same manner as for the Elevator. The AI D/R switch located above the right stick assembly is used when setting the Exponential Throw.

CPY (DATA COPY)

A valuable feature of the RDS8000 is the Data Copy Function. With this function, the entire set of control parameters for one aircraft can be 'copied' from one model set-up into another. For instance, if you have your aircraft program in Model #1 and nothing in Model #3, you can copy the Model #1 program into Model #3 with the copy function.

Having copied your control set-up, you can now use MSL (Model Select) to access the Model #3 program and then make control changes to that set-up. This allows you to experiment with different control options without changing your original parameters (in this example Model #1).

To use the CPY (copy) function, select "etc" on the Channel indicator using either the (CH -) or (CH +) key. Note that you must be on the STW screen to move horizontally across the screen to "etc".

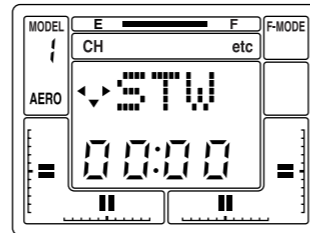
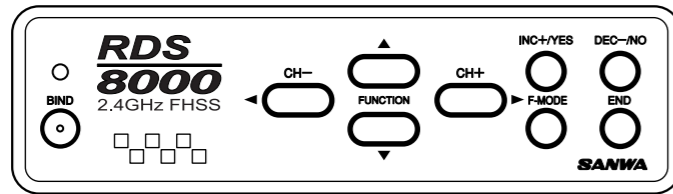

Press the FUNCTION down key to select the CPY (copy) Function.

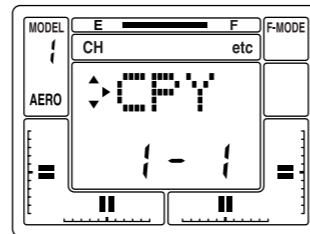
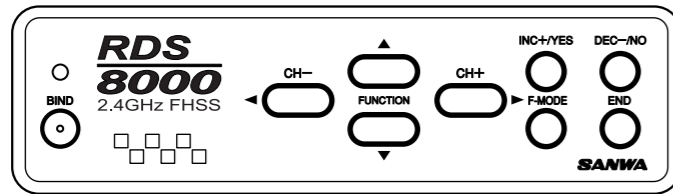

For this example, assume you want to copy the set-up of Model #1 (which you selected), to Model #3. The first number on the screen indicates the model number you are copying. The second number indicates the destination model. Press the INC +/YES key to change the destination to indicate Model #3. Note that one of the small triangles is blinking which indicates there is another screen associated with this function.

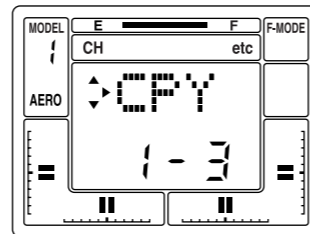
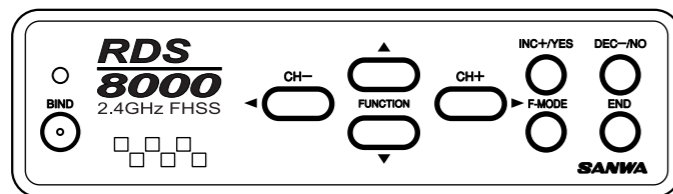

On the previous screen, the destination has been set to Model #3. MAKE CERTAIN that the current model setup is not one you wish to save, because when you copy the Model #1 set-up into Model #3, all data that was in Model #3 is replaced with the Model #1 data! At this point Model #3 data is still intact, so if you wish to change the destination for the copied data, do so before proceeding.

Having selected both the data source (Model #1) and the desired destination (in this example Model #3), you can now proceed to confirm the copy function.

Press the CH + > key to access the next screen as shown below. The "YES" will be blinking.

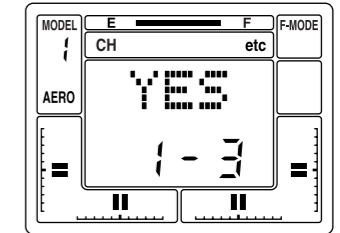
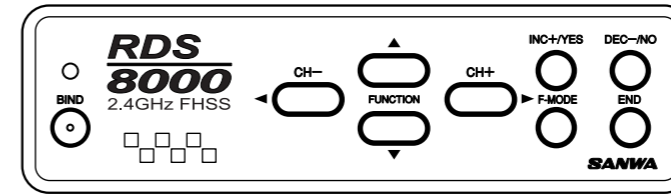

Press the INC +/YES key to confirm your data copy function. The screen will change to the following screen to inform you that the process has been completed, and that Model #1 and Model #3 now have the same data.

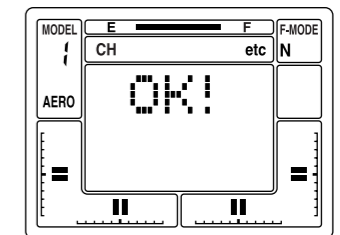
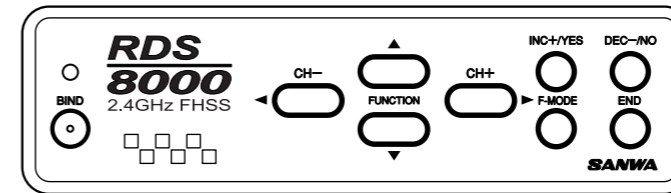

Press the END key to return to the CPY select screen.

SW-R (SWITCH REVERSE)

The SW-R Function allows you to reverse the action of the six toggle switches located on your RDS8000 transmitter. The default of the SW-R Function is the NOR (normal) position. CAUTION! The switch reversal function is not individually selective. If you change it from NOR (normal) to REV (reverse), all switches will be reversed in their action!

To access the SW-R Function, select "etc" on the Channel indicator using either the (CH -) or the (CH +) key. Note that you must be on the STW screen to move horizontally across the screen to "etc".

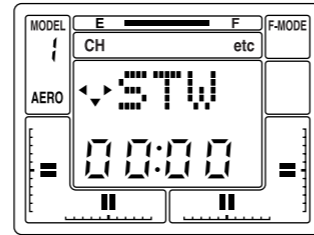
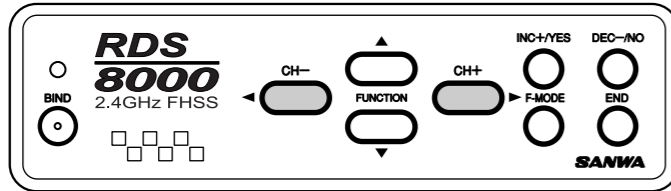

Press the FUNCTION down key to scroll down to the SW-R (switch reverse) screen.

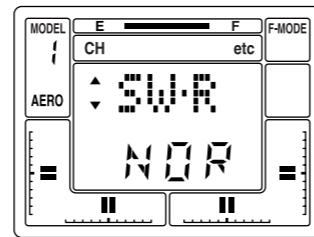
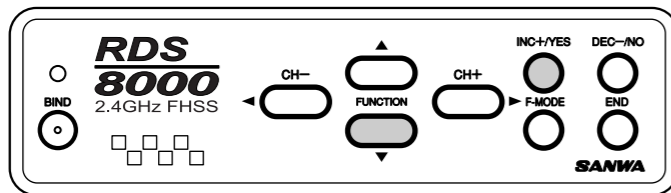

Now, press the INC +/YES or the DEC -/NO key to change the indication from NOR to REV. All switches on the transmitter are now reversed in their function. Press END to return to the STW screen.

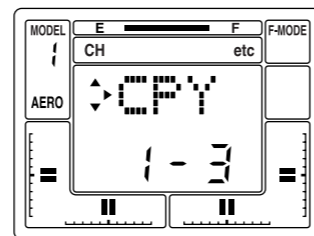
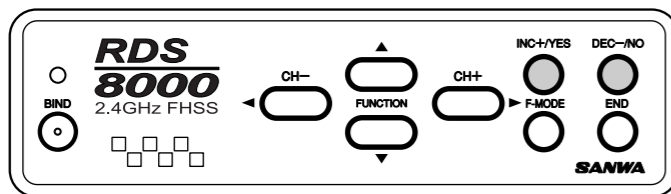

NOTE: NOR (normal) default (switch off) position: For top toggle switches is the up position and all four slide switches on the front of the transmitter are down or pulled towards you. Using the SW-R feature will change the default off position: To toggle switches down and all four slide switches pushed forward or up position as default off.

CLK (CLICK)

The RDS8000 transmitter is factory-set to emit an audio tone ("Click") whenever the programming keys are pressed, when values are changed, and when the stop watch function is started, stopped or reaches the final ten seconds of countdown.

It is possible to disable the "Click" or audio tone, using software settings. When disabled, ONLY the stopwatch count-down emit cause an audio tone.

To set or disable the "Click" function, select "etc" on the Channel indicator using either the (CH -) or the (CH +) key.

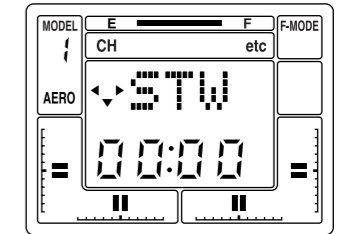
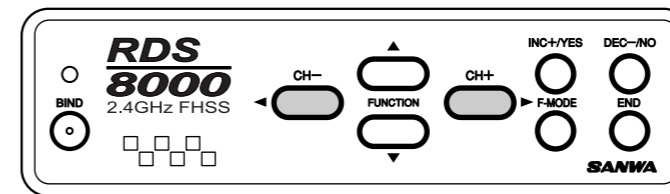

Press the FUNCTION down key to access the CLK (CLICK) screen.

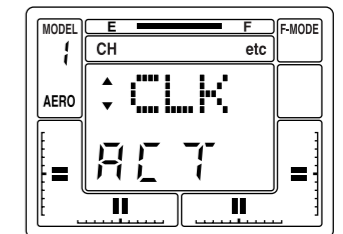
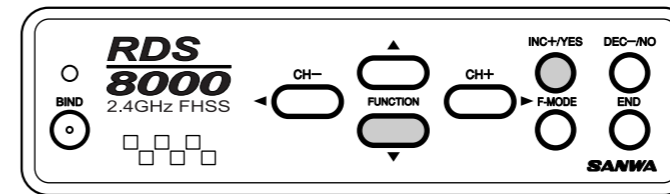

Press the INC +/YES key to change the indication from ACT to INH, to disable the Click function. (pressing either the INC +/YES or the DEC -/NO key will toggle the function between "INH and "ACT" settings

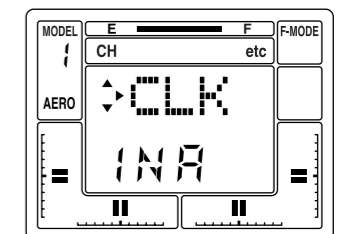
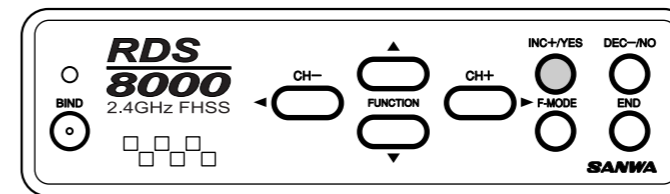

Press the END key to return to the STW screen.

T-CUT (THROTTLE-CUT)

Another useful function provided by the RDS8000 for engine-powered models is T-CUT, (Throttle Cut). Normally you set your throttle stick in the extreme low position and use EPA and the digital trim to obtain a steady engine idle speed. However, to stop the engine at the end of the flight you would have to use the throttle digital trim and later re-trim for proper idle. The T-CUT function eliminates that by providing a button that overrides the throttle stick low position and drives the throttle servo to a lower position, stopping the engine. The throttle stick must be in the low position for the throttle cut to function.

In order to use T-CUT, press either the (CH -) or the (CH +) key to select TH on the Channel indicator.

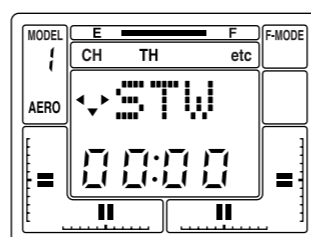
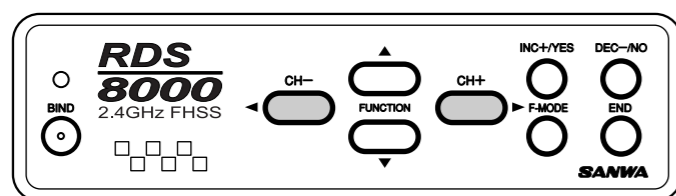

Next, press the FUNCTION down key several times to obtain the following screen.

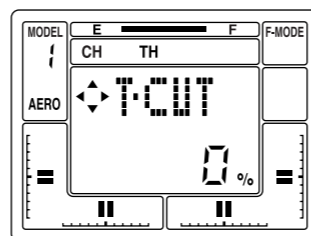
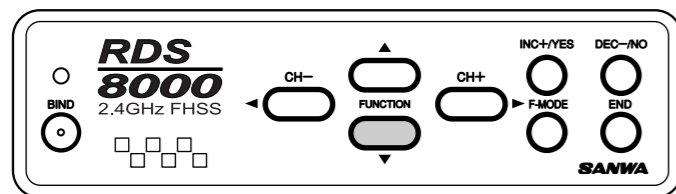

Press the DEC -/NO key to set a value of -100%. Place the throttle stick in the extreme low position. Press and hold down the Throttle Cut button located above the elevator/aileron stick assembly. The throttle servo will then rotate further to close the carburetor and stop the engine.

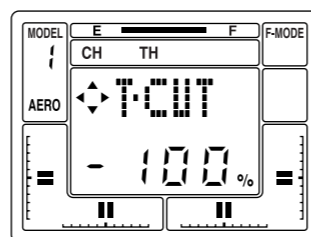
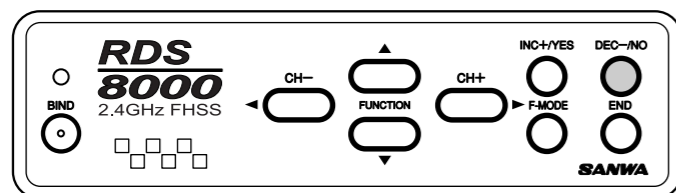

RDS8000 Transmitter - AIRCRAFT

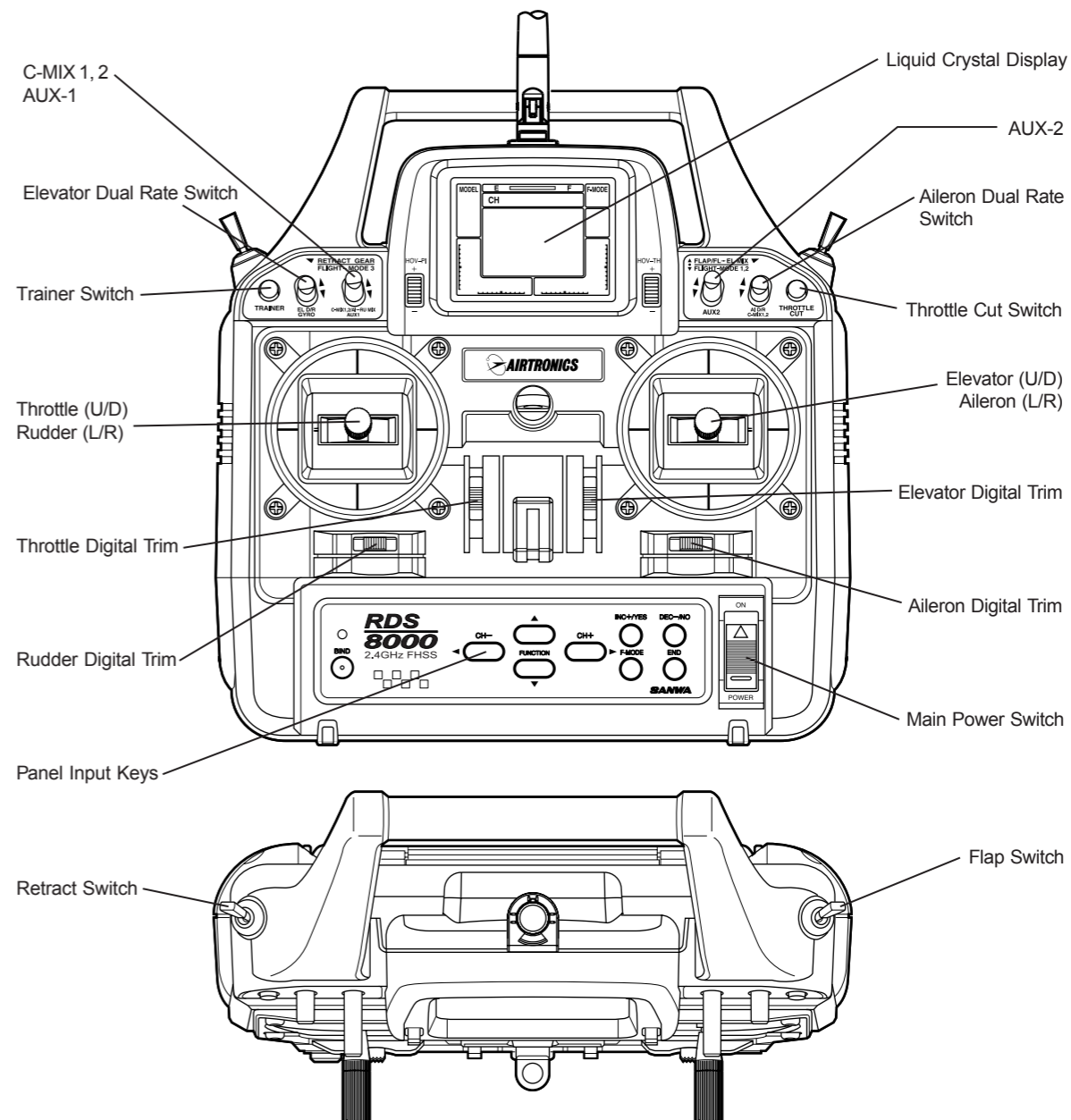

92824Z Receiver Channel Assignments

Receiver Slot Number	Plug in Servo For:
1	Elevator
2	Aileron
3	Throttle
4	Rudder
5	Gear
6	Flap or 2nd Aileron Servo
7	AUX 1
8/B	AUX 2 / Battery

AIRCRAFT BASIC MENU STRUCTURE

(Rx Channel)	CH	EL	AL	TH	RU	G	P/F	7	8	etc
		STW	STW	STW	STW	STW	STW	STW	STW	STW
		REV	REV	REV	REV	REV	REV	REV	REV	M-SL
		D/R	D/R	CNT	CNT	EPA	CNT	CNT	CNT	TYP
		CNT	CNT	EPA	EPA		EPA	EPA	EPA	RST
		EPA	EPA							BASIC

AIRCRAFT ADVANCED MENU STRUCTURE

(Rx Channel)	CH	EL	AL	TH	RU	G	P/F	7	8	etc
		STW	STW	STW	STW	STW	STW	STW	STW	STW
		TRM	TRM	TRM	TRM	REV	TRM	REV	REV	M-SL
		REV	REV	REV	REV	EPA	REV	CNT	CNT	NAM
		D/R	D/R	CNT	CNT		CNT	EPA	EPA	MAS1
		EXP	EXP	EPA	EPA		EPA			SLV1
		CNT	CNT	T>E	R>A		F>E			E>E1
		EPA	EPA	T-Cut	R>E					MAS2
		E>F	A>R							SLV2
										E>E2
										STW
										INT
										STEP
										TYP
										SW-R
										CPY
										RST
										CLK
										Flape
										Spoir
										Delta
										V-Tail
										D-EL
										AI-DIF
										L-DIF
										CR:LA
										CR:RA
										D/R-A
										BASIC
										OPT

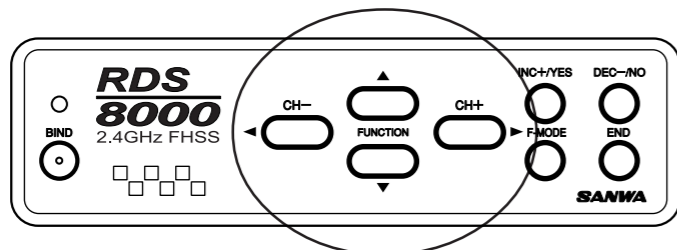

Use the four center buttons in the function panel to navigate through the menu's. (UP / DOWN / LEFT / RIGHT)

PROGRAMMING FOR AIRCRAFT

INITIAL SET-UP OF TYP (MODEL TYPE)

The RDS8000 transmitter is factory-programmed for fixed-wing aircraft models and helicopter models as follows:

- Model #1 is setup AERO
- Model #2 is setup HELI
- Model #3 is setup AERO
- Model #4 is setup HELI
- Model #5 is setup AERO
- Model #6 is setup HELI
- Model #7 is setup AERO
- Model #8 is setup HELI
- Model #9 is setup AERO
- Model #10 is setup HELI

If you fly only fixed wing model aircraft, you can change models 2, 4, 6, 8 and 10 to aircraft.

Turn the transmitter power ON and press the END key until you come to the default main screen. This screen will show AR1 as the aircraft type, and the NiCd battery voltage.

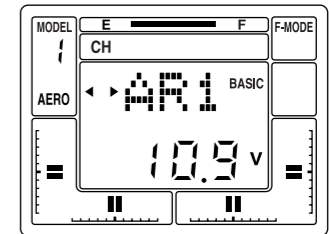
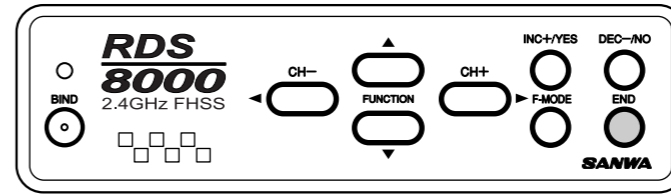

Press the (CH+) key to scroll across the CH (channel) indicator on the screen to "etc".

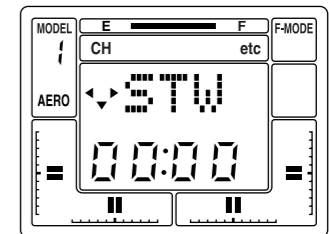
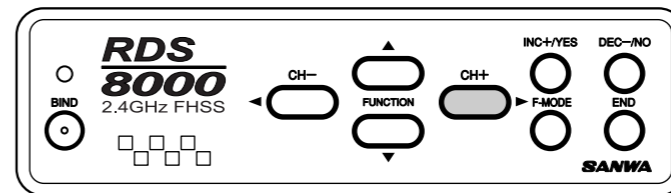

Press the FUNCTION down Key once to access the MSL (model select) screen.

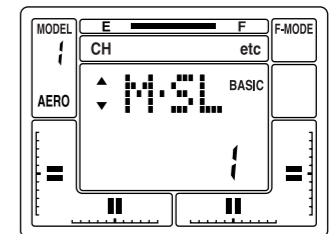
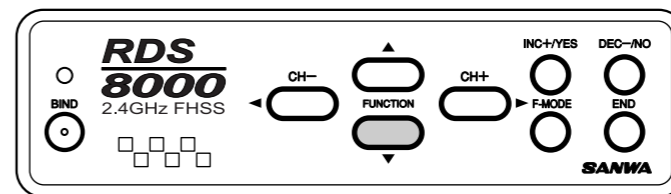

Press the INC+YES key until the screen reads HL2 (HELI model 2). Now press the END key. The screen will show model number two, which is a helicopter setup. However, since you are a fixed wing aircraft pilot, you want all of the transmitter setups to be fixed wing aircraft, the TYP (type) of aircraft must be changed from HELI to AERO.

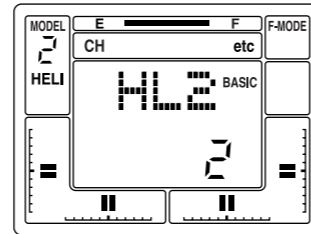
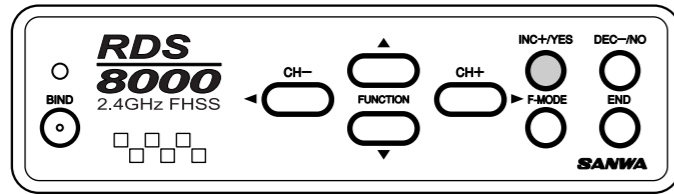

TYP (Type of Model)

To change the type of model, press the FUNCTION down key to select the TYP (model type) screen.

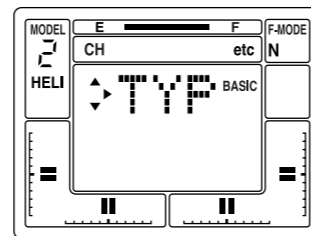
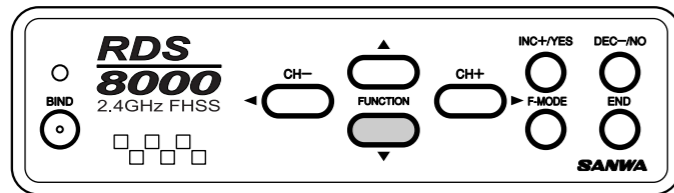

Note that one of the small triangular indicators will be blinking to show that you should press the (CH+) key. Therefore, press the (CH+) key and the screen will change to AERO with a flashing YES.

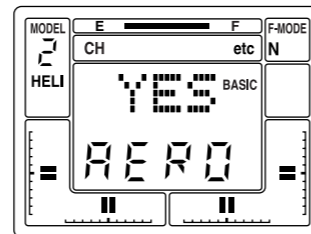
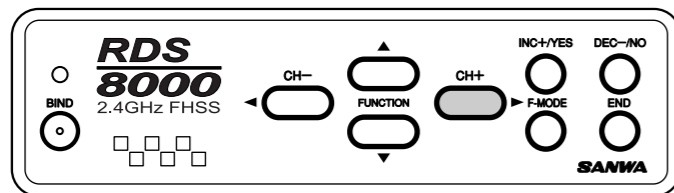

To confirm the change of aircraft type, press the INC+/YES key. The screen will then change to read OK! As shown on screen below to indicate the model type has been changed to AERO for model #2. Press the END key twice to return to the STW screen. The same procedure as above can be used to change model #4, 6, 8 and 10 from HELI to AERO.

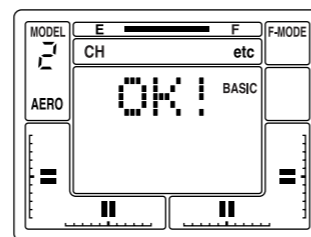
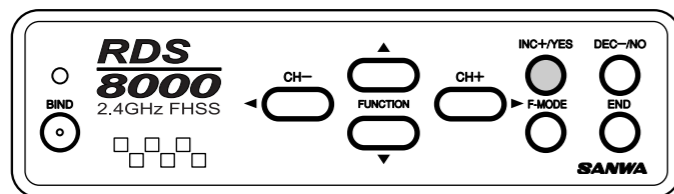

D/R (DUAL RATE)

Dual Rate adjustments, when operating your RDS8000 transmitter in the AERO mode, permits you to switch from your "standard" control deflection to a reduced amount of throw by simply flipping a switch. The actual speed of the signal processing and servo movement are not affected by the Dual Rate settings, only the amount of total throw available. Note when operating the Helicopter mode, Dual Rates for Elevator, Aileron and Rudder are set for each Flight Mode.

The RDS8000 allows Dual Rate settings for Aileron and Elevator. To access the Dual Rate setting for Elevator when you are on the STW or REV screen, press the FUNCTION down key to reach this screen.

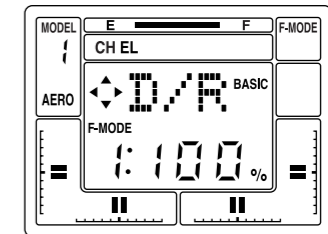
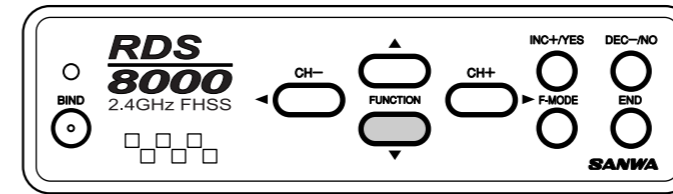

The screen tells you the present rate status, and when a Dual Rate is set to the ON position, the alternate rate for that control function that is presently set in the program. We are showing an example for the Elevator channel, however, all of the other channels are set in the same way.

The Dual Rate setting can be varied from 0 to 150%. Default for Dual Rate 1 is 100%. We recommend you leave it at that setting and only change the setting for Dual Rate 2. i.e., The convention for Dual Rate reduced-throw is the switch in the UP position to Turn ON Dual Rate. When you do so, note that the Screen will appear as follows. Press the INC +/YES or DEC -/NO key to increase or decrease the value. An initial setting of 50% is a good starting point and you can tailor it later following a test flight.

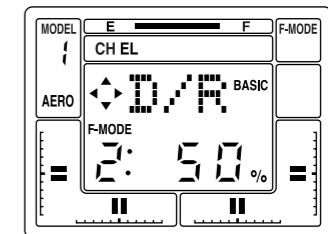
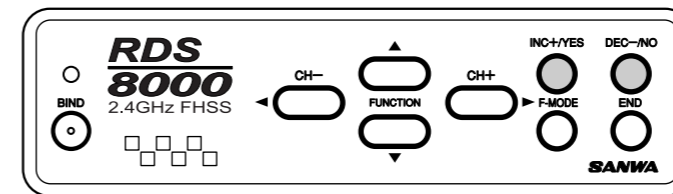

The Dual Rate switch for Aileron is located above the right stick assembly and is labeled AI D/R. Aileron Dual Rates are programmed in the same manner as the Elevator Dual Rates. To set it for Aileron, place the AI D/R switch in the upper position and use the DEC -/NO key to reduce the value shown on the screen to something less than 100%.

The RDS8000 permits you to set Dual Rate for the four distinct Flight Modes, e.g., Normal, 1, 2 and 3 for each helicopter. See page 67, PITCH Curves (FLIGHT MODES), for the description of the available Flight Modes. Dual Rate in a specific Flight Mode is set by first selecting D/R for Elevator, Aileron or Rudder. Press the F-MODE key to scroll through Flight Mode N, 1, 2 or 3 and set the value for Dual Rate. The Dual Rate can be varied from 0 to 150% The default value is 100% for all Dual Rates.

CAUTION: Prior to take off, check the position of both Dual Rate switches to make sure they are in the position you want!