

SANWA

USER MANUAL

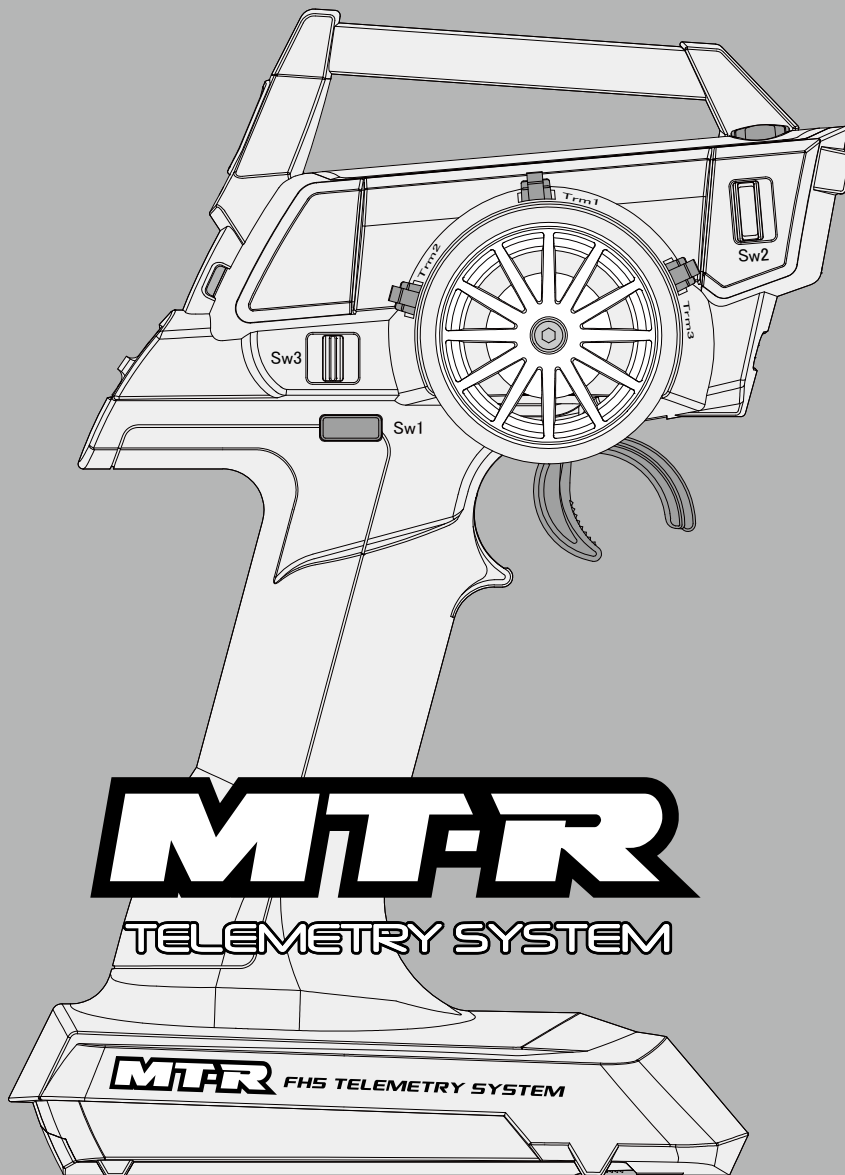

MTR

TELEMETRY SYSTEM

MTR FHS TELEMETRY SYSTEM

Safe Handling and Precautions

To use your purchased R/C System properly and safely, please read this instruction carefully and make sure to follow the precautions. Improper use of the product or negligence of following safety precautions can cause trouble to others or harm to the user.

■ For safety, please make sure to follow each of the precautions below.

Warning

Precautions for Installation and Operation

- When turning the power switch of R/C System on, please turn on in order of 1. Transmitter → 2. Receiver. And when turning the power switch off, please do so in order of 1. Receiver → 2. Transmitter.

☆ If you reverse the order of the switches, it causes sudden high rotation of the engine and the motor and it's extremely dangerous.

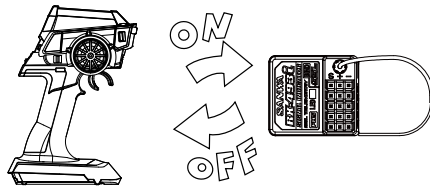

- Please use electrical noise countermeasure on the body of your car.
- ☆ If metals rub against each other, it causes electrical noise which may lead to abnormal performance. Please be sure that all screws and nuts are not loose.
- ☆ Nitro or gas engine and electric motor can cause noise also. Please use a noise countermeasure such as a plug with resistor or noise killer condenser.
- Please make sure to run a performance check (signalreception test) of R/C System before operation. When it moves abnormally or it doesn't move, please don't operate. Even if the test result on a desk is normal, please be cautious when operating for the first time especially, since the radio wave arrival distance varies depending on the installation method of the receiver, how the antenna is set, the direction of the transmitter antenna is facing and geography.
- Never operate on a rainy day.
- ☆ The interior of the transmitter is built with sensitive electronic parts. If water runs on the surface of the case and enters inside, it can cause abnormal performance or malfunction and it can be dangerous.
- ☆ If the receiver or a servo sinks in the water, immediately collect it and dry the interior. When the interior is dry, please submit it to the Sanwa Service for inspection even if it performs normally.

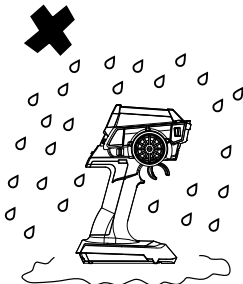

- The receiver is a precise instrument. Please do not add a strong impact or vibration.
- ☆ Use a thick sponge to prevent vibrations. Install the receiver as far as possible from the speed controller, motor and the battery.
- When installing the receiver on a metallic chassis or a carbon chassis, use three layers of double adhesive tape pieces to keep the receiver from touching the chassis.
- When there is a radio disturbance, change the installation location of the receiver or change from a vertical placement to a horizontal placement or vice versa.
- Don't place a motor cord or a battery cord close to the receiver since it can cause abnormal performance.
- Keep the antenna of the receiver out as much as possible. And keep it straight and stretched. Don't cut the extra length of the line or bend it.
- ☆ It's dangerous when the antenna is short since the range of travelling becomes narrow.
- ☆ Never cut the antenna.

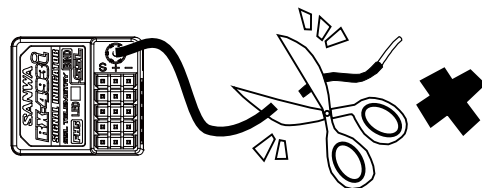

- Don't place the antenna close to a motor cord or a battery cord.
- Using a conductive piano wire on a metallic chassis or carbon chassis can cause abnormal performance from electrical noise. Don't place a piano wire close to the chassis.

Warning

Careful When Driving

When operating an RC car, please make sure to follow the following notes and avoid giving trouble to others.

- Maintain the body of the car (boat) in a perfect condition and check the safety.
- Do not operate an RC car in a crowd or on a public road.
- Make sure to disconnect the connector of the power battery and remove the power battery from the car after operation.
- When operating simultaneously with other RC users, make sure to have a control staff and follow the instruction of the control staff.
- Try not to interfere with other people's operation.
- Be sure to apply for a radio control insurance.
- For application to apply a radio control insurance, inquire a radio control operator registration agency.
- Be sure to install a "muffler (sound absorber)" with a silencing effect on an engine car.
- Don't start engine early in the morning.
- Please make sure to clean the location used for operation before you leave.

Caution

About Usage

- Do not use this RC system for other than model use.
- Since this product is manufactured for models based on the Radio Law in each country, it cannot be used in countries other than your original place of purchase.

Caution

Daily Care

- When the exhaust of the engine or fuel is on the radio, wipe it with a soft, dry cloth. When it gets dirty, please wipe it with a tightly squeezed clean soft cloth impregnated with water or neutral detergent. Thinner, benzene, alcohol, motor cleaner, brake cleaner, etc. may cause surface finish to deteriorate or degenerate, so please do not use.

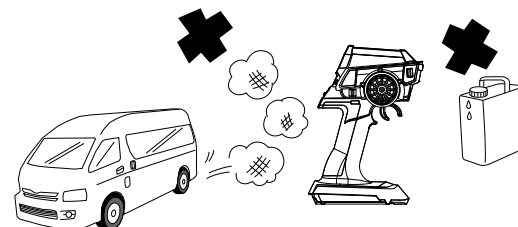

Caution

Handling Transmitter

- Please do not hit, drop or cause strong shocks. In addition, if you touch the transmitter, receiver, servo, FET speed controller, etc. with hands applied with tire traction agent, it will cause breakdown or case deformation.

Caution

About Storage

- Do not store in following places.
 - ☆ Extremely hot place or extremely cold place.
 - ☆ A place that is exposed to direct sunlight for a long time. Especially if you leave it in a place where direct sunlight hits like in a closed car window, the interior temperature becomes 80 0 C or more depending on the season, so please be careful as it may cause deformation or breakdown.
 - ☆ A place with high humidity, poor ventilation.
 - ☆ A place with considerable vibrations.
 - ☆ Places with high dust places subjected to steam or hot air.
 - ☆ A place that gets exhaust gas from an engine or a place near the fuel tank.

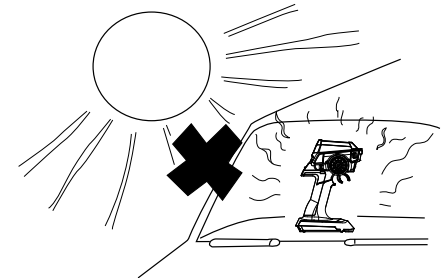

Meaning of the mark

- ! **Caution** Things you are expected to do to prevent accidents and injuries.
- ! **Warning** Things that you should follow in order to prevent break down.

Safe Handling and Precautions

INDEX



Warning Note Precautions for Safe Use

- 2.4 GHz frequency band is not only used for radio control. This frequency band is shared with ISM (Industry, Science and Medical) band. It can be affected by microwave ovens, wireless LAN, digital cordless telephones, audio equipment, Bluetooth of game machines or cell phones and short-range communication such as VICS. Also, be cautious about being affected by amateur radio and premises radio stations for moving body identification since this frequency band is used for them as well. When a harmful radio frequency interference is done to an existing radio station, stop the transmission of the radio frequency immediately and take a measure to avoid the interference.
- For RC circuit, minimize the use of equipment that can affect 2.4 GHz systems and make sure to check the safety beforehand. Also, follow the instruction of the facility manager.
- When operating the models behind a building or a steel tower, blocking the direction of radio wave transmission can cause reduction of operation response or loss of control. Always operate within the range you can visually check.
- Don't grab the transmitter antenna. Doing so can be dangerous since it can weaken the radio signal output and narrow the range of operation.
- Don't attach any metal parts around the antenna of the transmitter.
- If you have the transmitter's antenna extremely close to a servo or speed controller other than the receiver, it can cause malfunction but it is an influence of a strong high frequency output and it is not abnormal.
- The receiver is a precise instrument. Don't subject it to strong impact or vibrations. Use a thick sponge to prevent vibrations.
- Keep the antenna wire of the receiver out as much as possible. And keep it straight and stretched. Don't cut the extra length of the antenna line or bend it.
- Keep the antenna wire of the receiver out as much as possible. And keep it straight and stretched. Don't cut the extra length of the antenna line or bend it.
- Don't place the antenna wire of the receiver close to a electrical noise source like a motor wire or a battery wire.
- When installing the receiver on a metallic chassis or a carbon chassis, use layers of double adhesive tape pieces to keep the receiver from touching the chassis as much as possible.

■ Structure and the Standard of the Set	5
● Structure of The Set (5)	
● Set Specification (5)	
■ Before Using	6-7
● Adjusting Tension of The Steering and Throttle (6)	
● Adjusting The Adjustable Trigger (7)	
● About The Power Source, Bind (7)	
■ Names of Each Part of The Transmitter	8
■ Connections and Installation of Receiver	9,10
● About Receiver, And How to Handling The Antenna (9)	
● About Connection Setup (10)	
■ Before Driving A RC Car	13-16
● How To Place Servo Horn (13)	
● How To Set Reverse [REV] (13)	
● How To Set Sub Trim [SUB-T] (14)	
● Sub Trim and Trim Differences (14)	
● How To Set End Point Adjustment [EPA] (15)	
● How To Set Dual Rate [D/R] (16)	
■ How To Use Each Feature	11,12,17-52
● About Key Operation (11)	
● About the Display Panel (12)	
● About the Menu Structure (17)	
● Setting [SETTING] (18-34)	
· Dual Rates [D/R] (18)	
· Speed [SPEED] (19)	
· Curve [CURVE] (20)	
· Fail Safe [F/S] (21)	
· Base [BASE] (22-24)	
· Reverse [REV] (22)	
· Sub Trim [SUB-T] (22)	
· End Point Adjustment [EPA] (23-24)	
· Function [FUNC] (25-28)	
· Trim [TRIM] (25)	
· Anti-Lock Brake [ALB] (26)	
· Offset [OFFSET] (27)	
· Throttle Type [TH TYPE] (28)	
● AUX [AUX] (29-34)	
· Step AUX [STEP AUX] (29)	
· Point AUX [POINT AUX] (30)	
· 4 Wheel Steering [4WS] (31)	
· Motor On Axle [MOA] (32)	
· AUX Mixing [AUX-MIX] (33)	
· Code AUX [CODE AUX] (34)	
● Model [MODEL] (35-38)	
· Model Select [MODEL SELECT] (35)	
· Model Name [MODEL NAME] (36)	
· Model Copy [MODEL COPY] (37)	
· Model Clear [MODEL CLEAR] (38)	
● Timer [TIMER] (39-40)	
· Lap Timer [LAP TIMER] (39)	
· Interval Timer [INT TIMER] (40)	
· Down Timer [DOWN TIMER] (40)	
● Telemetry [TELEMETRY] (41-42)	
· Logger [LOGGER] (41)	
· Alert Setting [ALERT SETTING] (42)	
· Telemetry Setting [TELEMETRY SETTING] (42)	
● System [SYSTEM] (43-48)	
· Bind [BIND] (43-44)	
· Key Assign Switch [KEY ASSIGN SW] (45)	
· Key Assign Trim [KEY ASSIGN TRIM] (46)	
· Buzzer [BUZZER] (47)	
· Battery [BATTERY] (47)	
· LCD [LCD] (48)	
· Calibration [CALIBRATION] (48)	
● Setup Wizard (49-50)	
● About Quick Setup Wizard (51-52)	
■ Assign Function List	53
■ Transmitter LED Indication List	54
■ Index	55
■ When this happens...	56
■ Service and Support	57
■ FCC Compliance Statement	58

Structure and the Standard of the Set

STRUCTURE OF THE SET

	MT-R RX-493i PC (Primary Component)
<A> Transmitter	MT-R (TX-4101)
 Receiver	RX-493i
<C> Servo	—
<D> Accesories	Brake Trigger +1/+2 x each 1 Receiver Dust Cover x1 Bind Plug x1 Antenna Pipe x1 User Manual x1

●Please check items before use

SET SPECIFICATION

<A> Transmitter	
Product No.	MT-R (TX-4101)
Output Display	Digital display (Power Source Voltage Display)
Modulation	2.4 GHz Spread Spectrum System
Power Source	AA BATT x4 (Corresponding VOLT: DC4.8 - 7.4 V)
Weight	366 g

 Receiver	
Product No.	RX-493i
Modulation	2.4GHz Spread Spectrum System
Size	26.0x23.2x14.0mm
Power Source	DC3.7~7.4V
Weight	6.2 g

*Be careful with the input voltage.
If voltage above allowable voltage is inputted, the transmitter will be damaged.

Before Using

ADJUSTING THE STEERING AND THROTTLE TENSION

MT-R can adjust the tension of the steering/throttle trigger to match operation of the steering/throttle to the user's preference.

Adjusting the Steering Tension

By inserting a hex wrench driver (1.5mm) to the place where the arrow is pointing at in the illustration on the right and turning, you can adjust the tension of the steering spring.

*The spring tension is the softest at the time when the product is shipped out from the factory. As you tighten with a hexagon wrench driver (1.5mm), the spring tension will be hardened.

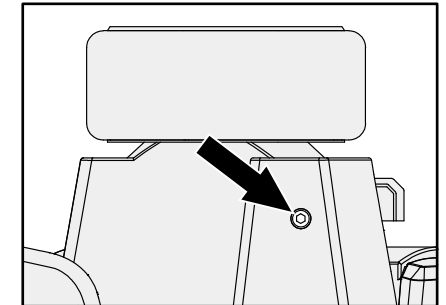

Adjusting the Throttle Trigger Tension

By inserting a hex wrench driver (1.5mm) to the place where the arrow is pointing at in the illustration on the right and turning, you can adjust the tension of the throttle spring.

*Please do CALIBRATION when changing steering and throttle tension. (p.48)

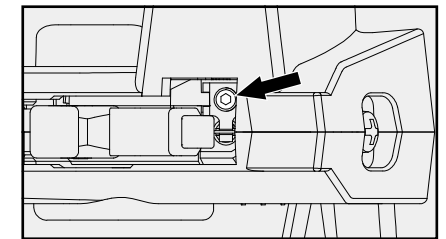

ADJUSTING THE ADJUSTABLE TRIGGER

MT-R can adjust the throttle trigger position fitting to the user's hand size.

Adjusting the trigger position

Loosen the fixing screws of the trigger on the back of the transmitter. Then, adjust the adjusting screw of the trigger position on the back of the transmitter to set the trigger at the position of your preference. When you turn the adjusting screw of the trigger position clockwise, the trigger position gauge moves to the direction A. By turning it counter clockwise, the trigger position gauge moves to the direction B.

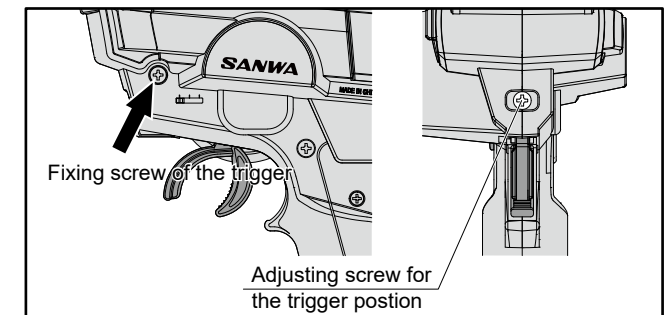

*The range of the trigger movement is 7mm. If you turn the screw forcefully beyond the range, it can cause malfunction. Once you set the trigger position, tighten the fixing screw and adjusting the trigger is done.

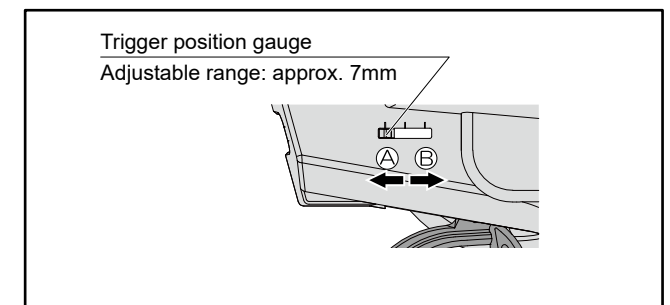

*Be careful with the direction of turning the screw because the trigger position is set at the furthest point of the A side at the factory.

*Setting Advice
Please fit trigger position to your finger naturally. It would be smoother to operate braking.

Before Using

ADJUSTING THE ADJUSTABLE TRIGGER

Adjusting the brake trigger

You can adjust brake trigger position according to your fingers by replacing the included brake trigger.

Standard Size, +1 Size, +2 Size is included.

- 1) Remove the brake trigger fixing screw.
- 2) Select Brake Trigger according to your fingers.
- 3) Fix the brake trigger by the screw.

*Setting Advice

If you feel much gaps between a finger with trigger, please change brake trigger to +1 or +2.

After changing the brake trigger size, please check the differences while driving.

Combination of trigger position and brake trigger adjustment would give optimum operation by fitting to personal hand.

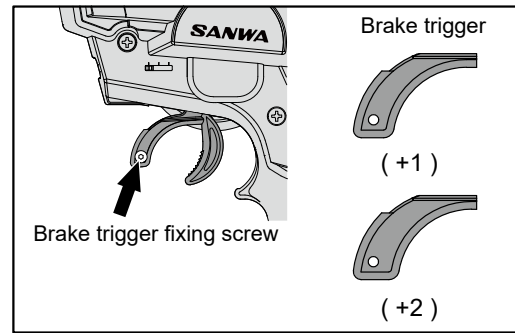

ABOUT THE POWER SOURCE

HOW TO PLACE THE TRANSMITTER BATTERIES

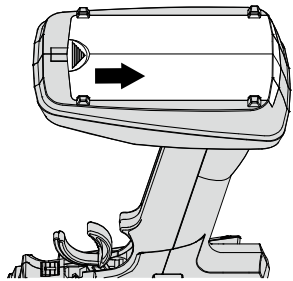

<1>Open the battery compartment cover by sliding the cover to the direction of the arrow while pressing it lightly.

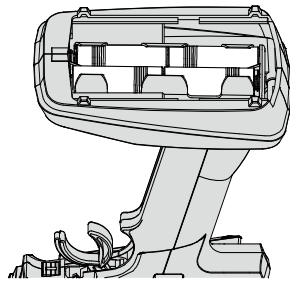

<2>Place 4 size AA batteries. Make sure to observe correct polarities.

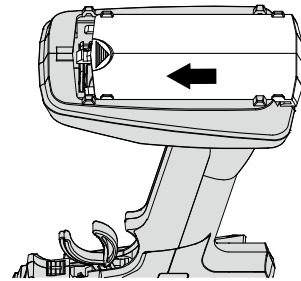

<3>Align the convex part of the battery compartment cover and the groove of the battery compartment, slide the cover to the direction of the arrow and close tightly.

ABOUT BIND

● About Bind

Each MT-R transmitter has own ID number for transmission. Receiver memorizes the ID number to bind.

After binding, the transmitter can work with the receiver and the antenna are installed.

- BINDING is not done at the factory. Please make sure to complete BINDING before use.
- When the receiver is new, make sure to complete BINDING for the transmitter and the new receiver.
- Make sure to use the set of the transmitter and the receiver that completed BINDING.

*About details of bind, please refer p.43-44 in this manual.

Name of Each Part of Transmitter

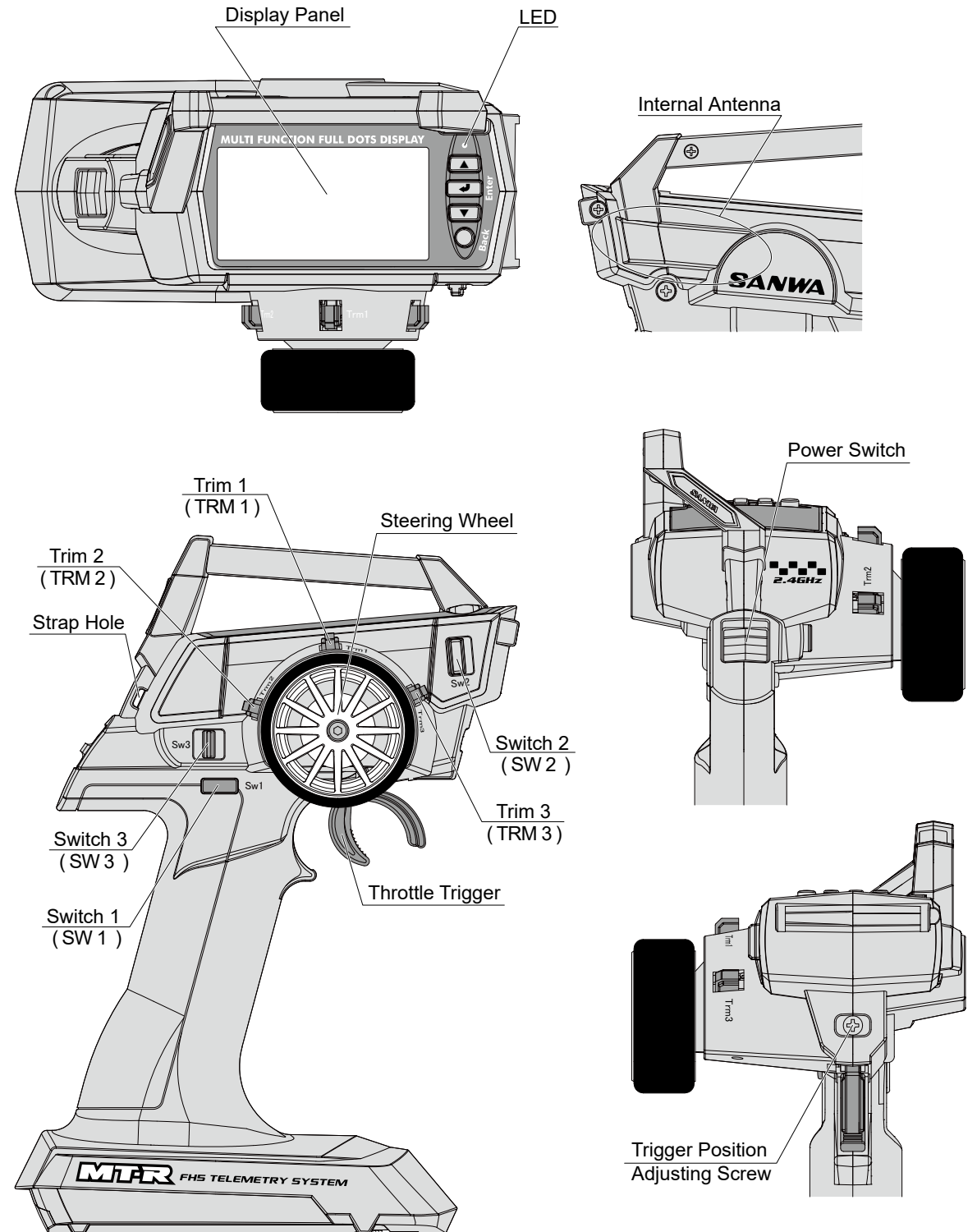

Name of Each Part of Transmitter

Connections and Installation of Receiver

ABOUT THE RECEIVER

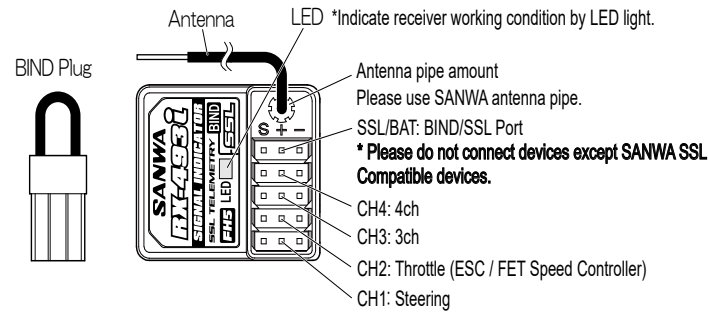

Indication of Receiver Working Condition by LED light

Connected	Blue light On *When binding with 2 transmitter, blue light flash at 2 sec intervals.
NOT Connected	—
In BIND Setting	Blue light flashing Blue light blinking
Battery Fail Safe Working	Blue and red light on
Receiver is not connected in Battery Fail Safe working	Red light on

● RX-493i

RX-493i can evaluate received signal strength and packet delivery ratio from transmitter.

*MT-R cannot check received signal strength and packet delivery ratio.

RX-493i can store 2 transmitter ID Number. It is able to combine using individual transmitter which is different setting in endurance race .

If you bind with 2 different transmitter, the receiver store the different transmitter and can operate by transmitters without re-bind.

*CANNOT operate by the 2 different transmitter at the same time. 2 ID store system is only compatible with M17, MT-5, or MT-R.

Throttle neutral position or operation quantities might be different each transmitter. Please adjust each transmitter setting to fit chassis linkage.

When setting SSL compatible devices by MT-R CODE AUX function, please connect SSL compatible device to SSL port.

MUST set fail-safe setting on each transmitter.

Please set same RF mode and response mode as 1st transmitter when you bind 2nd transmitter. If it was different mode, cannot bind with 2 transmitters.

*If 2nd transmitter was different RF node and response mode from 1st transmitter, 1st transmitter ID No. is deleted and only write 2nd transmitter.

*If you bound 3rd transmitter, 1st transmitter ID No. will be deleted.

*When using first time, please bind with receiver. (p.43)

ABOUT HANDLING THE ANTENNA

- Reception distance may vary depending on the location where the receiver and the antenna are installed.
- To protect the reception part (3 cm from the top) of the antenna, make sure to place the antenna in the antenna pipe as shown in the right illustration so that the top of the antenna is not exposed outside of the antenna pipe.
- Don't bend the antenna reception part or the antenna coaxial cable because breaking can occur inside.
- Don't pull the coaxial cable forcefully. It may damage the receiver interior.
- Install the antenna on an RC car so that the antenna reception part is in as high place as possible.
- Don't cut or bind the antenna reception part or the antenna coaxial cable since the receiver sensitivity might decrease.
- Keep the receiver antenna away from the motor and the ESC / FET Speed Controller (including cables) and raise it straight.

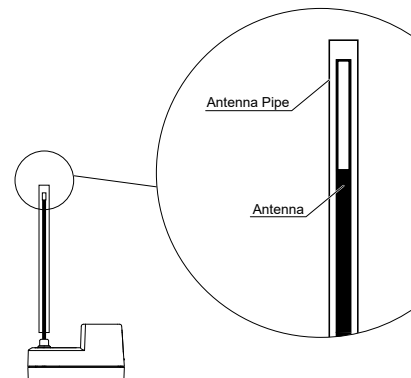

ABOUT CONNECTION SETUP

Please refer the below picture for receiver and servo connection

●Connection example in case of using in EP car

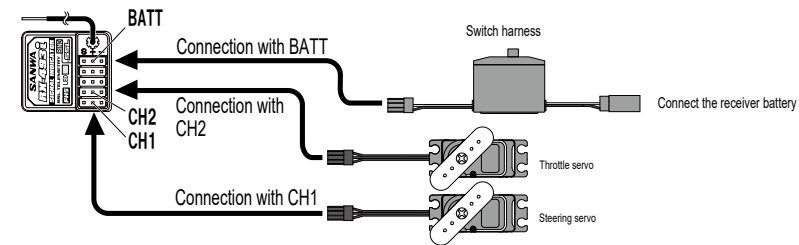
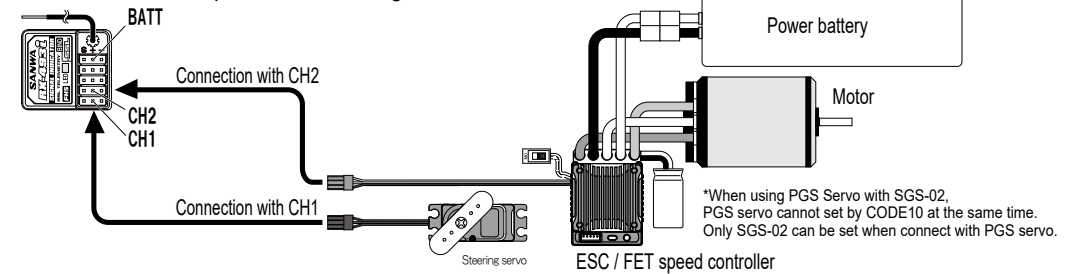

■Case of connecting PGS servo and SUPER VORTEX Gen2/PRO/SUPER VORTEX Stock to SSL port

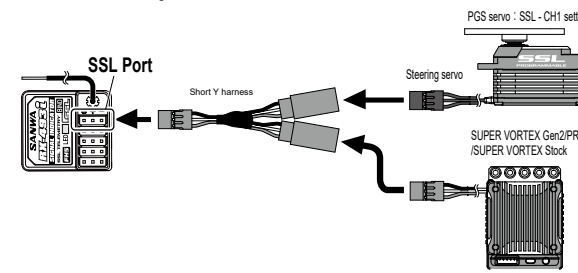

- Set AUX TYPE of the transmitter for both AUX1, AUX2 to CODE 10.
- AUX1 CODE10: Setting of SUPER VORTEX Gen2 / PRO /SUPER VORTEX Stock can be from the transmitter.
- AUX2 CODE10: Setting of each of the parameters of PGS II servo can be from transmitter.
- Note)In SUPER VORTEX Gen2 / PRO, do not assign function to CODE 10 of AUX2 by code assign of PROGRAM BOX Gen2. It interferes with CODE 10 of AUX2 of PGS servo and suitable setting cannot be done.
- Note)Set SSL-CH of PGS servo to [1]. (Factory setting of PGS servo is [1].)
- Note)CODE of AUX2 is used for SUPER VORTEX ZERO / SUPER VORTEX TYPE-D / SUPER VORTEX SPORT. It interferes with CODE 10 of AUX2 of PGS servo and suitable setting cannot be done. Therefore, it cannot be used along with SSL of PGS servo.
- Note)When Connecting PGS servo with SGS-02 cannot change setting at the same time. When using SGS-02, Gain connector connect to SSL port.
- *Please DO NOT connect another devices except SANWA SSL compatible products. About setting and connection, please refer manuals of SSL compatible product.

■Case of connecting PGS servo to 2 SSL ports

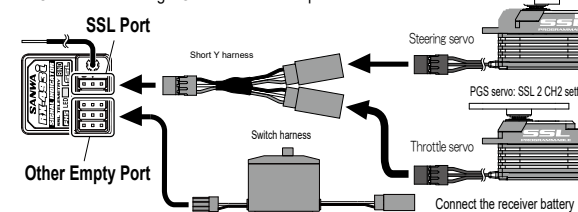

- Set AUX TYPE of AUX2 of the transmitter to CODE 10.
- AUX2 CODE10: Setting of each of the parameters of PGS servo can be done from the transmitter.
- Note)Set SSL-CH of PGS servo used in steering servo to [1].
- Set SSL-CH of PGS servo used in throttle servo to [2]. (Factory setting of PGS servo is [1].)
- Note)In case of setting each parameter by the function of CODE10 of AUX2, setting of PGS servo of SSL-port set by CODE1 of AUX2 can be directly changed from the transmitter. PGS servo not specified by CODE1 of AUX2 works on the parameters saved inside.

*Please, refer on our Website about any other examples. <http://www.sanwa-denshi.co.jp>

! Note

- If the connector is disconnected due to a vibration during operation, it can cause runaway. Connect the connector of the receiver, servos and switches securely.
 - Because the receiver is susceptible to vibration, impact and water, make sure to take measures for vibration-proof and waterproof. Negligence of taking these measures can cause runaway.
 - When installing the receiver, keep the receiver away from a carbon chassis and metallic chassis.
 - If metal parts installed on an RC car touch each other, it can cause noise that affects reception performance and it can cause runaway.
 - Make sure to install a noise killer condenser on the brush motor for electric RC cars. Without a noise killer condenser, it can cause noise and runaway.
 - For R/C System parts such as the transmitter, receiver, servos, ESC (FET Speed Controller) and transmitter battery, use genuine SANWA products.
- *When combining products other than genuine SANWA products, modifying, adjusting or exchanging parts is done at a place other than SANWA, we do not take any responsibility.

How to Use Each Feature

ABOUT KEY OPERATION

- The user can set up and make a calling easily with each key.

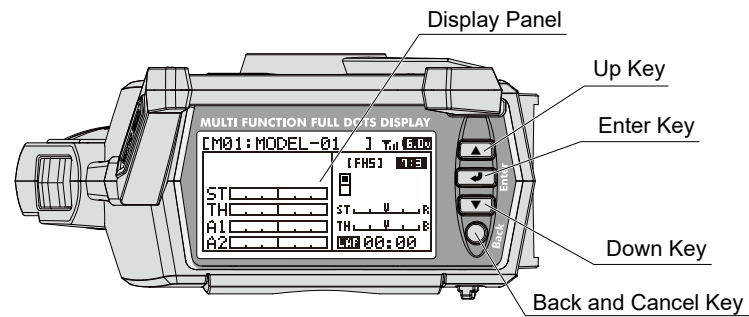

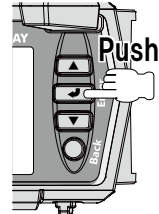
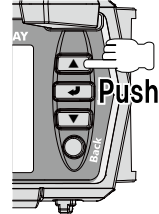
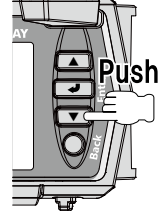
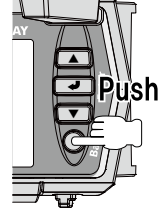
Key Operation	Names	Performance
	Enter	<ul style="list-style-type: none"> Moves to the setup screen from the top screen. Selects a feature and item to set. *By long pressing the Enter, the setting goes back to default.
	Up	<ul style="list-style-type: none"> The cursor moves upward. The set value increases.
	Down	<ul style="list-style-type: none"> Moves the cursor downward. The set value decreases.
	Back / Cancel	<ul style="list-style-type: none"> Goes back to one step before. Cancels the setting.

ABOUT DISPLAY PANEL

- Each feature of MT-R can be selected directly by each key.
- You can set up each channel feature separately.
- As you turn the power switch on, the top screen launches after the boost screen is displayed (when the boot setting is on). When changing each setting, select the menu by enter operation.

Top Menu

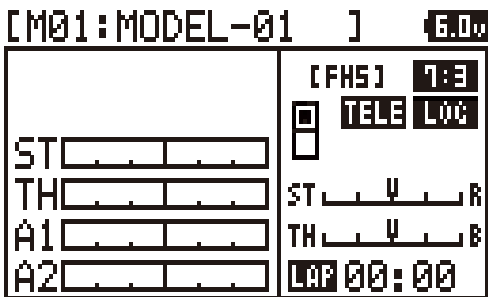

Telemetry Menu

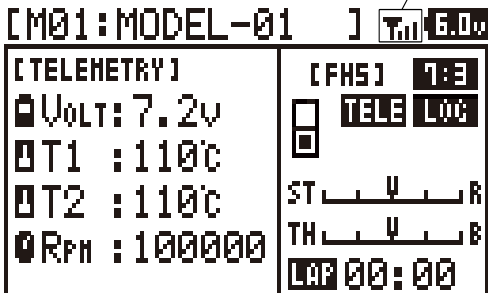

Menu Window

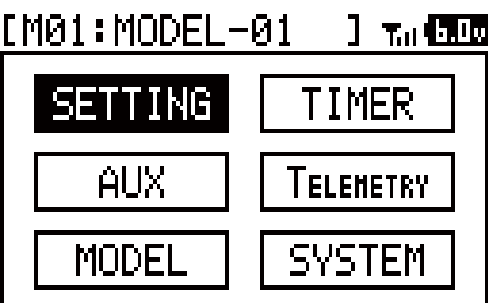

Antenna mark will be shown while using telemetry

↑ BACK
↓ ENTER

When using RX-491/492/493/493i and SUPER VORTEX Series/PGS Servo Series/SGS-02, Turn telemetry function on, then display telemetry data from receiver.

Before Driving A Car

HOW TO PLACE SERVO ARM

- Power the servo will be returned neutral position.
- Turn on binded receiver and transmitter before taking on servo horn.
- Be sure about transmitter Trim and Sub Trim are no setting (value is 0).
In case Trim and Sub Trim did not set 0, please set 0 for these setting.
- Please place servo arm on center position such as the below picture.
*Servo horn angle may not be 90 degree due to RC car type.
Please place servo horn to follow instruction manual of RC car.

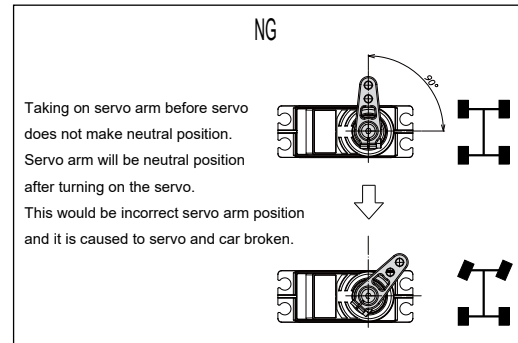
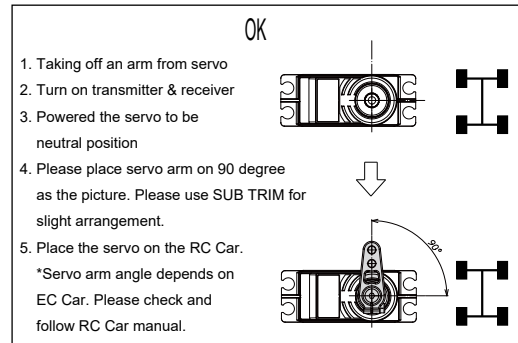

HOW TO SET REVERSE [REV]

- Please check steering operation and tire direction are same after tacking on servo arm.
- Please set REVERSE in case steering operation and tire direction are different. About REVERSE setting please refer p.22 in this manual.

REV Setting Requirement

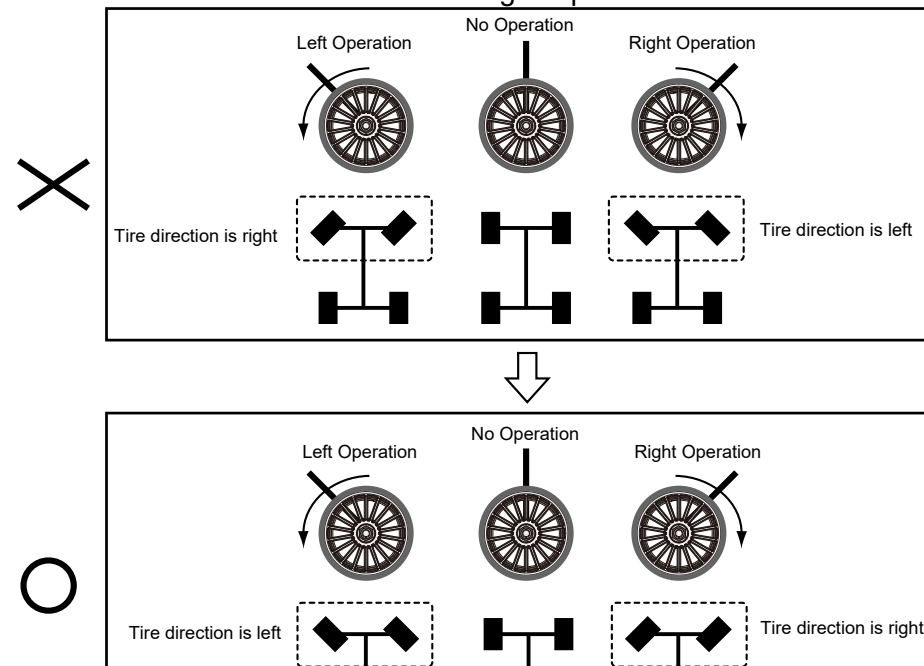

HOW TO SET SUB TRIM [SUB-T]

- In case servo cannot place correctly as 90 degree or RC Car manual instruction, please arrange neutral position by SUB TRIM setting. About SUB TRIM setting, please refer p.22 on this manual.

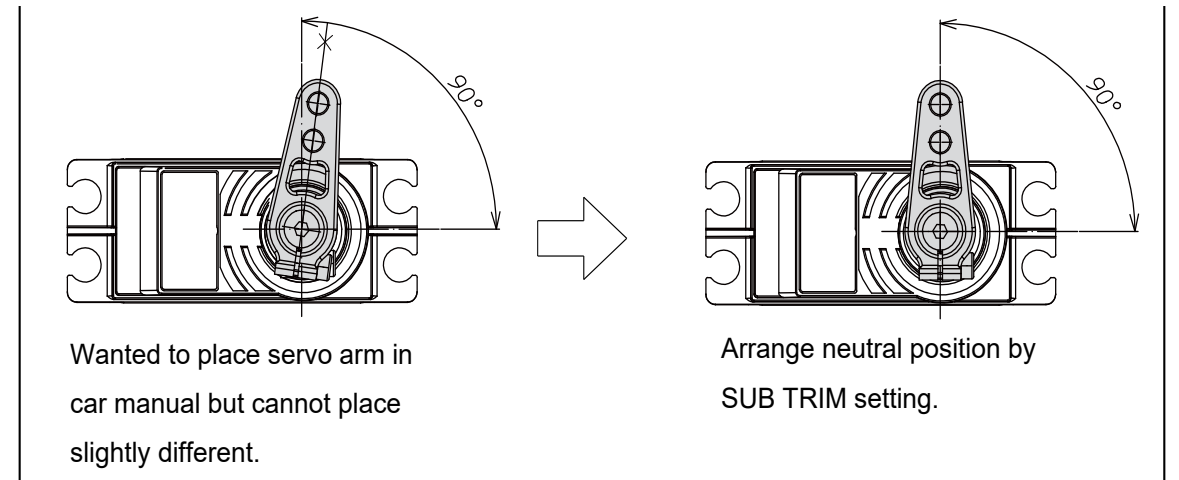

SUB TRIM AND TRIM DIFFERENCES

- SUB TRIM is for neutral position and mainly used on the pit as taking on servo horn. TRIM is for driving arrangement and mainly used while driving such as below picture. Please refer p.22 in this manual.

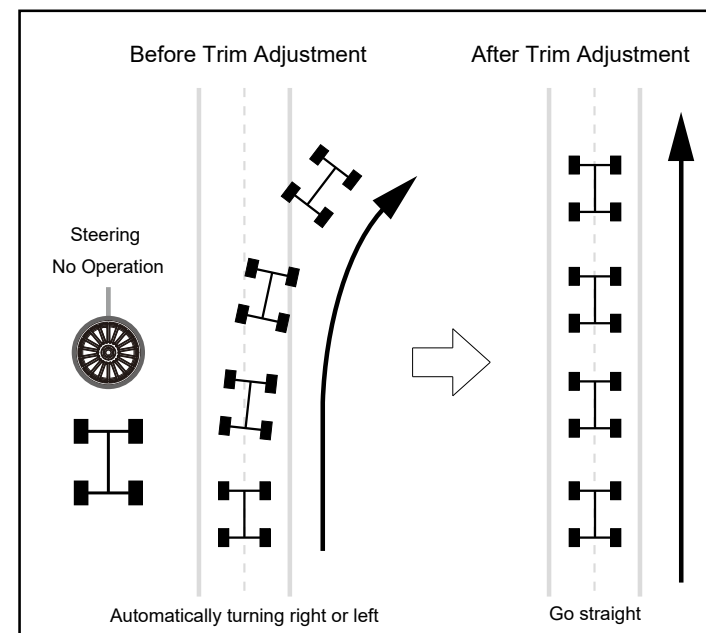

*RC car did not go straight as accident. TRIM is used for direction arrangement.

Before Driving A Car

HOW TO SET END POINT ADJUSTMENT [EPA]

- Adjust right and left maximum steering angle are same after setting SUB TRIM.
- *In case of not setting EPA, right and left cornering are different as the below picture. This may be caused to servo broken. Please refer p.23 in this manual.

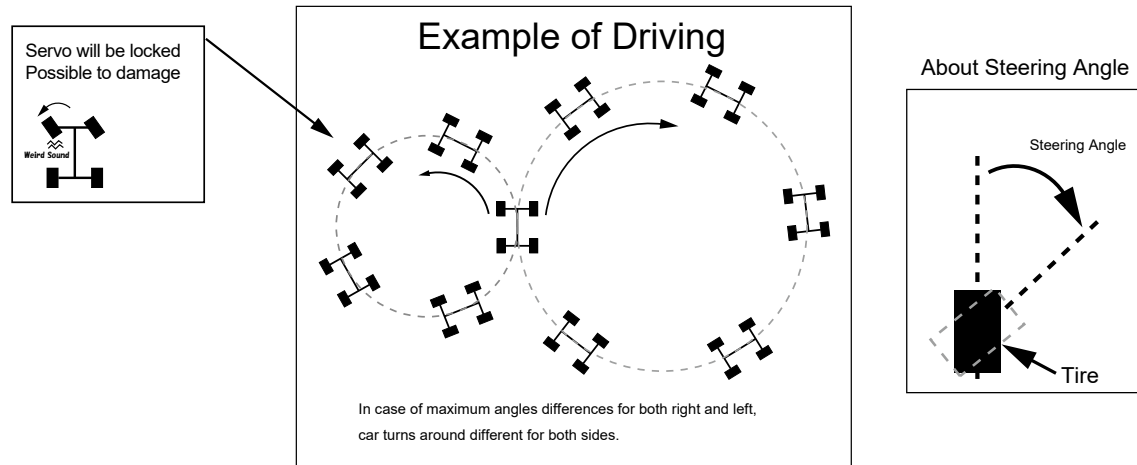

*Please arrange EPA setting as the below picture and make sure same maximum steering angles for both right and left.

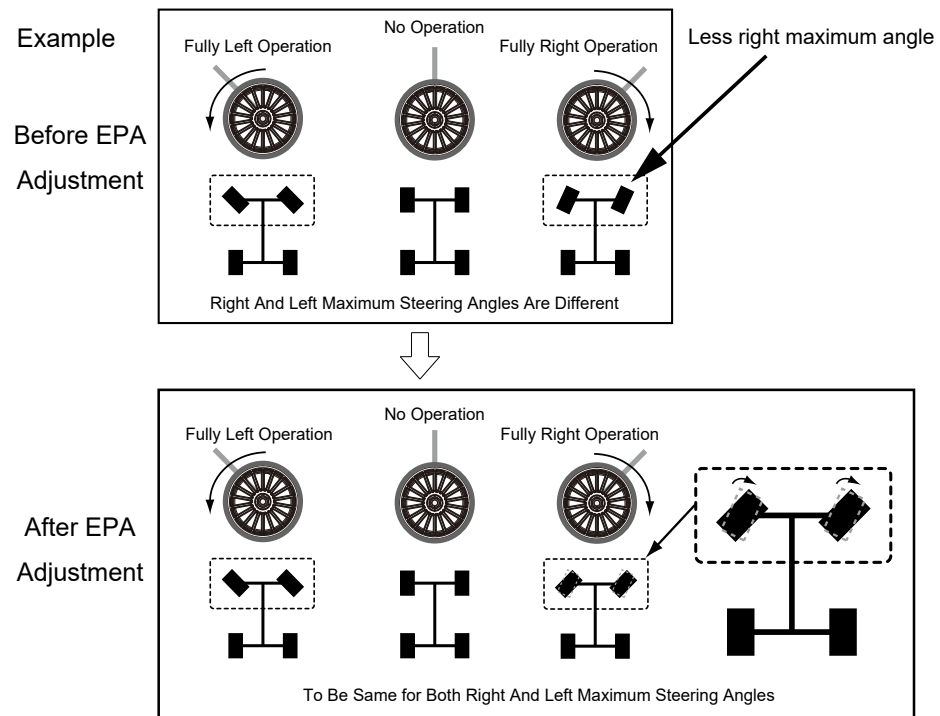

HOW TO SET DUAL RATE [D/R]

- About Steering Operation
- In case RC car is too much cornering and difficult to drive, DUAL RATE(D/R) adjust maximum steering angle.
- EPA adjust each left and right maximum steering angle.
- D/R adjust both left and right maximum steering angle at the same time and same ratio.
- Please refer p.18 on this manual.

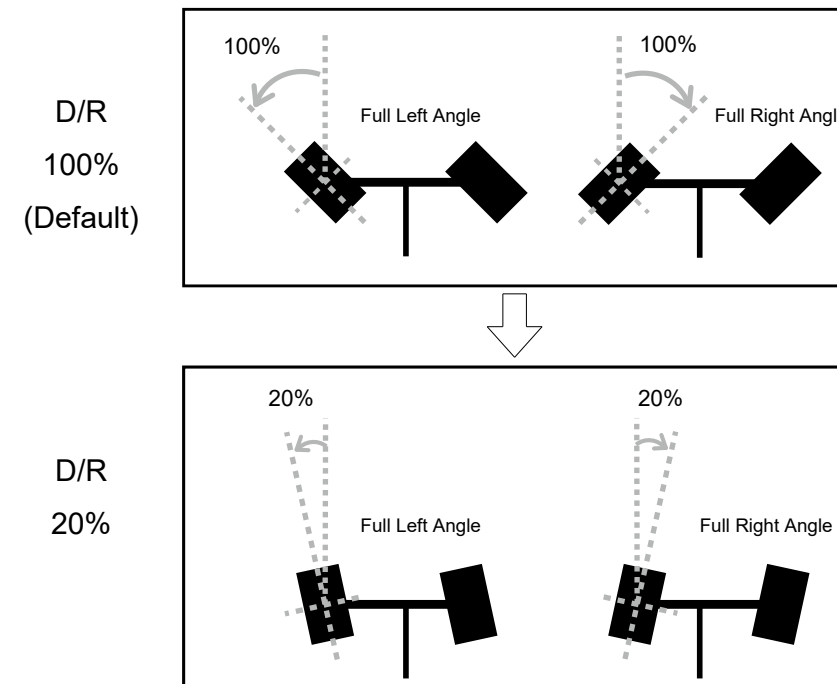

How to Use Each Feature

ABOUT THE MENU STRUCTURE

- The user can set up features and do model memory call easily by using each key.
- The Menu consists of Setting, AUX, Model, Timer, Telemetry and System Menu, and related features are included in each menu.

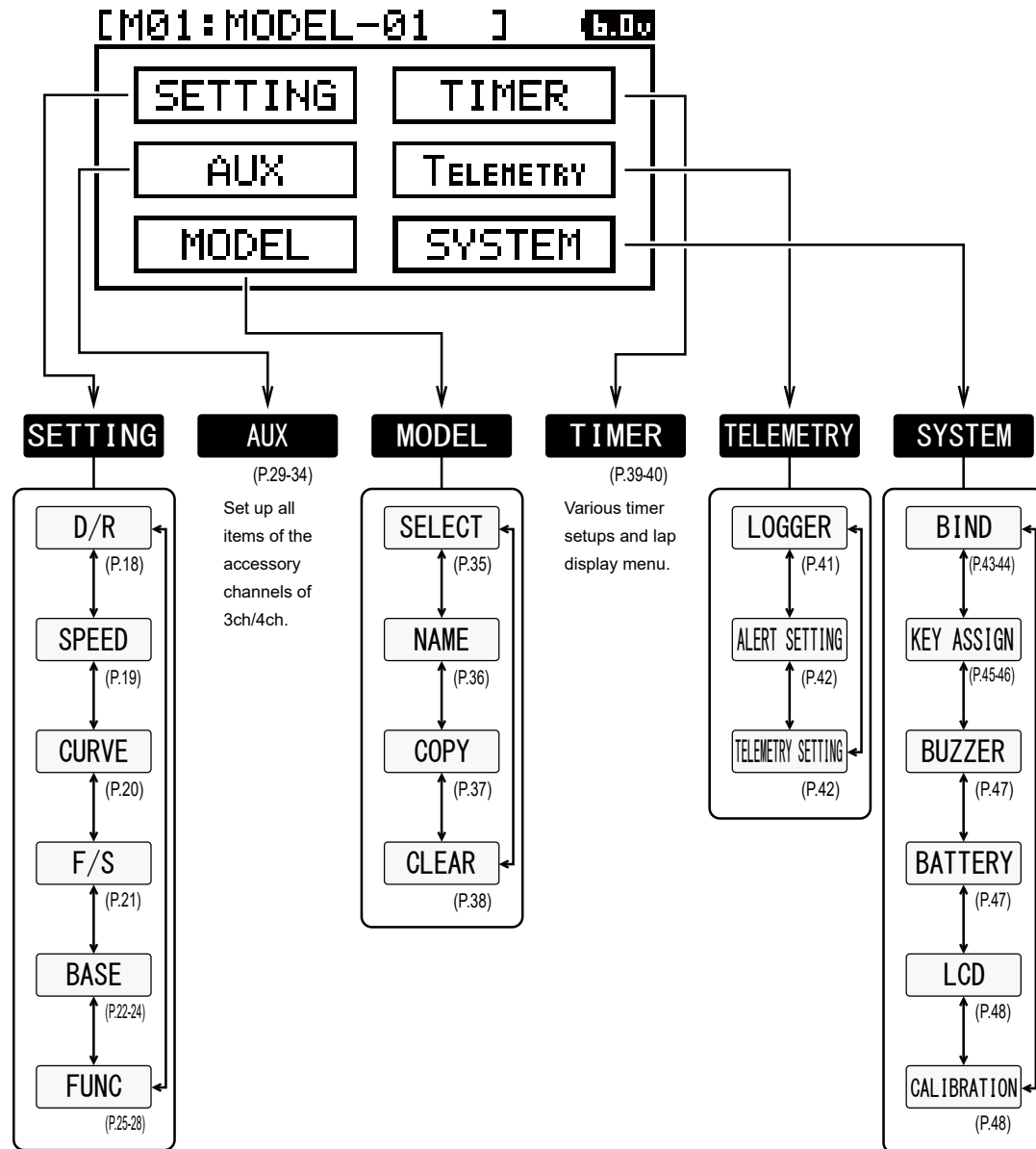

DUAL RATE [D/R]

SETTING

- You can adjust steering angle when operating the steering wheel and throttle trigger to their peak. Please adjust the steering angle to fit RC car and surface condition when driving.
*You can adjust steering for both right and left at the same time and throttle separately for high and brake sides. You can also adjust the brake side more precisely than adjusting with EPA.
- Don't increase the setting rate of dual rates (D/R) from the condition in which the linkage locks by operating the steering wheel and throttle trigger.
- You can also adjust more precisely by adjusting dual rates of the throttle side.
*A1 and A2 cannot be set even moving to D/R on A1 and A2 page.

- 1) Select features [ST/TH/BR] to adjust with the up and down key.
- 2) Determine the feature to adjust with the Enter key. Adjust the value of DUAL RATE by up and down key.
- 3) During operation, the steering dual rates can be adjusted with Trim 3. It's possible to assign other features to Trim 3 with the key assign trim feature (P. 46).

*When cancelling a selected feature, operate the Back key.
*Depending on car types, dual rate is not assigned to TRIM3.

- Setting Range:
ST/TH: 0%~100%
BR: 0%~120%
- Default:
ST/TH/BR: 100%

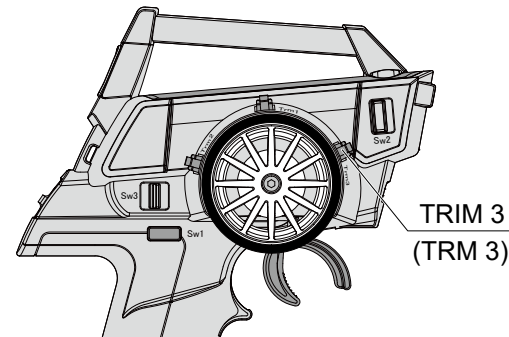

*Make sure that the servos do not lock to make clicking sound!

Note) The same for throttle.

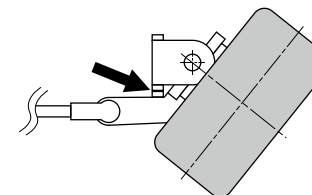

! Note • If the linkage is locked for a long period, it can cause the servo motor breakage.

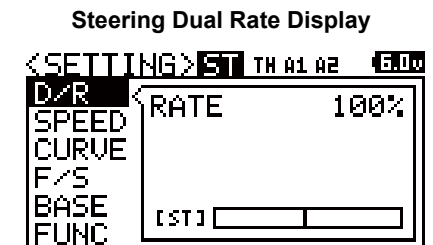

↓ ENTER

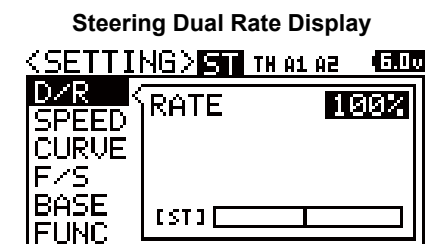

SUPPLEMENT

- Adjust the end point of the steering/throttle linkage before adjusting dual rates (P. 23, 24).

How to Use Each Feature

SPEED

SETTING

- Features to control the speed of the servos used for steering and throttle. By setting, the RC car is not affected even when doing a sudden operation. On the steering side, smooth corner work becomes possible and on the throttle side, stable rising from a corner by throttle work with saved power.
- *When setting AUX TYPE to [CODE], adjusting the speed feature of the AUX channel does not affect the performance.
- *When setting the speed of the AUX channel, do so using steering/throttle as a reference.

[ST] STEERING SPEED

- A feature to delay the speed of the steering servos against the steering operation. You can set speed for steering forward and returning individually. For steering operation slower than setting, the speed feature does not work.

- 1) [ST (Steering)] with up and down key.
- 2) Setting on the forward side [FORWARD]
Select [FORWARD] with the Enter key and adjust the setting value by up and down key.

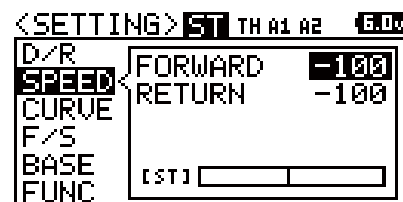
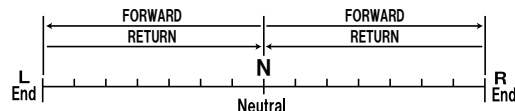

- 3) Setting on the Return side [RETURN]
Select [RETURN] with the Enter key and adjust the setting value with by up and down key.

- Setting Range: 0~-100
- Default: 0

- 3) Setting on the Return side [RETURN]
Select [RETURN] with the Enter key and adjust the setting value with by up and down key.

- Setting Range: 0~-100
- Default: 0

*Adjust during actual operation. When not using the features or when a setting value cannot be determined even after adjustment, set the value to 0% (linear).

SUPPLEMENT

- For driving an RC car, steering operation that suits the movement of the RC car is important and excessive operation is not recommended. Steering speed can minimize unnecessary operation and enables smooth cornering.
- When steering speed and steering curve are combined, the effect is doubled.

[TH] THROTTLE SPEED

- A feature to slow down the performance speed of the throttle servos and delay the response of the speed controller against throttle operation. You can set speed for entering throttle (Forward) and returning (Return) individually. The speed feature does not work with throttle operation slower than the setting.

*Setting is only for High side and Brake side cannot be set.

- 1) Select [TH (Throttle)] with up and down key.
- 2) Setting on the forward side [FORWARD]
Select [FORWARD] with the Enter key and adjust the setting value by up and down key.

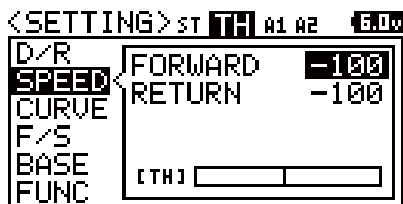
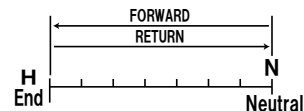

- 3) Setting on the Return side (RETURN)
Select [RETURN] with the Enter key and adjust the setting value by up and down key.

- Setting Range: 0~-100
- Default: 0

- 3) Setting on the Return side (RETURN)
Select [RETURN] with the Enter key and adjust the setting value by up and down key.

- Setting Range: 0~-100
- Default: 0

*Adjust during actual operation. When not using the features or when a setting value cannot be determined even after adjustment, set the value to 0% (linear).

SUPPLEMENT

- For driving an RC car, throttle operation that suits the movement of the RC car is important and excessive operation is not recommended. Throttle SPEED can minimize unnecessary operation and enables smooth performance.
- When throttle SPEED and throttle CURVE are combined, the effect is doubled.

CURVE

SETTING

- Curve changes servo work rate by steering and throttle position. It responds quickly when the set value is on plus (+) side whereas it responds mildly when the set value is on minus (-) side.
- MT-R has adjustable rate controller (ARC) of linear position.
- *If the AUX type is set to [CODE], curve does not work.
- *Please adjust curve setting on AUX channel to refer steering and throttle.

Adjustable rate controller (ARC)

Position at where operation is variable can be changed by adjusting the setting of POINT.

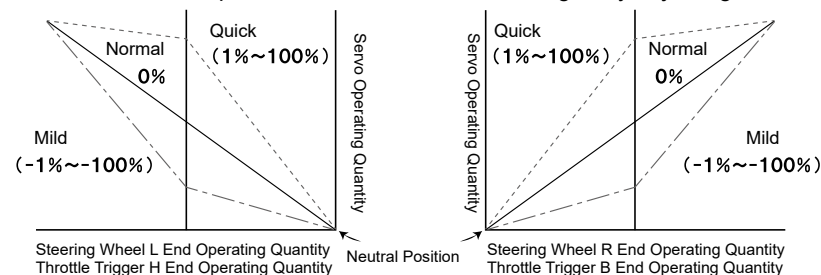

[ST] STEERING CURVE

- You can change the steering feature from Mild to Linear and to Quick.
- If you find your RC car oversteering, change the setting to the minus side and if you find understeering, change to the plus side. Steering Adjustable Rate Control is a simultaneous setting for L and R.

- 1) Select ST with up and down key.
- 2) Setting Rate [RATE]
Select [RATE] and adjust the setting value with up and down key.

- Setting Range: -100~100%
- Default: 0%

- 3) Setting Point [POINT]
Select [POINT] and adjust the setting value with up and down key.

- Setting Range: 5~95%
- Default: 50%

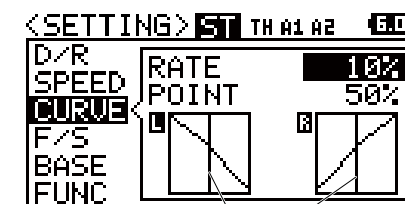

Point Setting Position

[TH] THROTTLE CURVE

- You can change the throttle feature from Mild to Linear and to Quick.
- In general, when operating on a slippery road or if you find over powering, change the setting to the minus side. When operating on a high-grip road or if you find lack of power in the power unit, change to the plus side. You can set the High side and the brake side separately.
- *Selection of the High side and the brake side is done by trigger operation.

- 1) Select TH with up and down key.
- 2) Setting Rate [RATE]
Select [RATE] with with up and down key.
Adjust the setting value.

- Setting Range: -100~100%
- Default: 0%

- 3) Setting Point [POINT]
Select [POINT] with up and down key.
Adjust the setting value.

- Setting Range: 5~95%
- Default: 50%

*When cancelling a selected feature, use the Back button.

Select H/B by Throttle Trigger

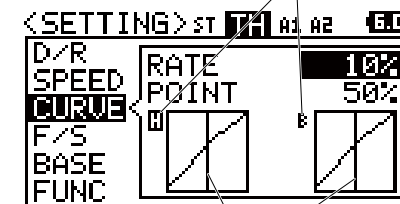

Point Setting Position

1. If you feel slippy while driving drift car, please set High side point 20 to 30% and Rate -15 to -30%. It can be more smooth and getting traction easily. *Please arrange ideal point and rate values while driving.

2. In case of using motor of stock class, please set High side point 20 to 30% and Rate 15 to 30%. It would give quick throttle timing and get more car acceleration.

How to Use Each Feature

FAIL SAFE [F/S]

SETTING

- Fail Safe Operation is a feature to keep the servos in a predetermined position for each channel in the event that the receiver cannot receive a signal from the transmitter. A feature to keep the servos in a predetermined position for the servo of the throttle channel (2ch) in the event that the battery voltage on the receiver side of an engine RC car goes below the set voltage is Battery Fail Safe Operation.
 - Battery Fail Safe Operation cannot be set when the throttle channel (2ch) is set to FREE/HOLD (*Battery Fail Safe Operation works only for the throttle channel).
- *Don't use Battery Fail Safe Operation for electric RC cars.

1) Select F/S with up and down key and select a channel to set fail safe operation (ST/TH/A1/A2).

2) Enter the set channel and operate by up and down key.

The fail safe mode setting changes in order of
FREE→FS→HOLD.

- Setting Range: FREE/FS(-100~100%)/HOLD
- Default: FREE

FREE (Free Mode)

When the receiver cannot receive the signal from the transmitter, the signal output to the servo stops and the servo will be free.

FS (Fail Safe Mode)

When the receiver cannot receive the signal from the transmitter, the servo will be held in the set position.

HOLD(Hold Mode)

The last position before the signal from the transmitter to the receiver is lost will be held.

*When the receiver can receive the signal from the transmitter again, each mode of FREE/HOLD/FS is automatically released.

3) Setting the Fail Safe (FS)

Move to the position where the Fail Safe Operation is used. When the position is determined, holding the Enter key to set the position when the Fail Safe Operation works.

*For safety, we recommend setting the throttle channel on the brake side when setting the Fail Safe.

4) Setting the Battery Fail Safe Operation

After setting the throttle channel position, move the cursor to [B-F/S] to set the voltage.

- Setting Range: OFF, 3.5v ~7.4v

*The Battery Fail Safe Operation is a feature to activate Fail Safe Operation when the receiver battery voltage belows to the set voltage on a Nitro car.

Don't use the Battery Fail Safe feature on electric RC cars.

5) Checking the Fail Safe Operation

Turn off the power of the transmitter while the Fail Safe Operation is set and check if the servo moves to the position where the Fail Safe Operation is set.

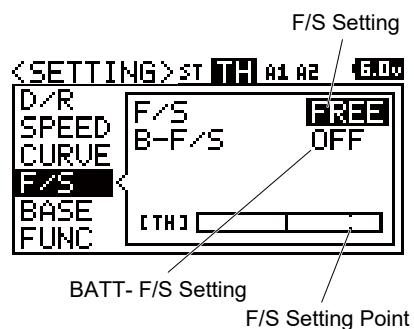
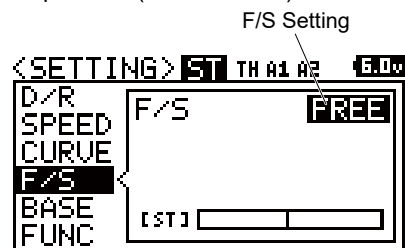

IMPORTANT

- About the Fail Safe Operation
When the Fail Safe feature is on, check the setting of the Fail Safe before operating. Don't change the setting of the Fail Safe during operation.

BASE

SETTING

- Base sets multiple functions all at once such as the Reverse that determines the direction of the servo of each channel, the speed controller according to a specific RC car, the Sub Trim that adjusts the neutral position, and the End Point Adjustment [EPA].

REVERSE [REV]

- This is used when operation and the movement of the servo are reversed while operating Steering/throttle/AUX1/AUX2.

1) Select BASE with up and down key

Select a channel to set (ST/TH/A1/A2).

2) Enter with the channel to be set by using up and down key.

The Reverse setting will be changed.

*When cancelling a selected feature, use the back key.

- Setting Range: NOR/REV

- Default: NOR

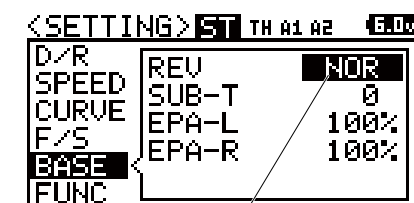

REV Setting

SUB TRIM [SUB-T]

- Using the Sub Trim feature, correct the neutral (center) of Steering/Throttle/A1/A2 so that Trim can be used from the center position. When installing a servo on to an RC car, center the servo with Sub Trim first before adjusting End Point Adjustment.

1) Before using, center (0) each main trim.

2) Select SUB-T with up and down key

Select a channel (ST/TH/A1/A2) to adjust Sub Trim.

3) Set the channel by Enter key.

4) Install the servo horn (servo saver horn) as close to centered as possible.

*For installation position of the servo horn, follow a car product instruction.

5) Adjust the center by using up and down key.

- Setting Range: L150~R150(ST)

H150~B150(TH)

H150~L150(AUX1, AUX2)

- Default: 0

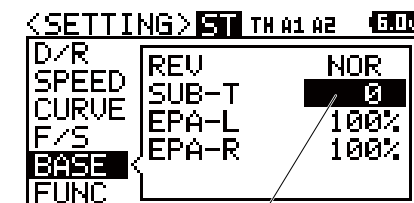

Setting SUB-T

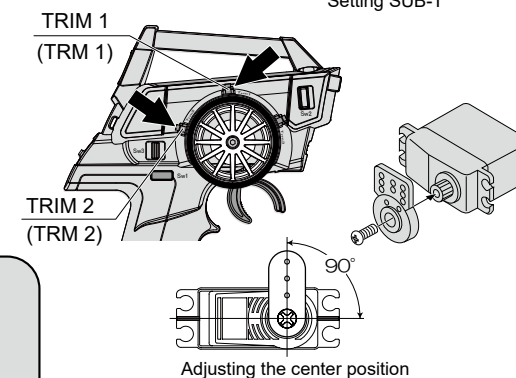

Adjusting the center position

Note

When installing the servo horn onto your servo, fix the servo horn as close to the center as possible and center it with Sub Trim. If Sub Trim and the transmitter main trim are off to one side, it causes dead band (the range the servo does not move) to the steering wheel and the throttle trigger.

About Trim and Sub Trim

Trim is a feature for adjusting the neutral (center) position of the servo. When your model does not run straight after installing the steering servo onto the model, Trim adjusts the main trim of the steering. Also, the neutral position of the carburetor on RC cars needs neutral adjustment of the throttle servo along with linkage adjustment after installing the servo. Neutral position adjustment is necessary not only after installing the servo but for changes that happen during running such as tire wears and chassis twist. MT-R Trim features two types of Trim including Center Trim that adjusts only the neutral position without changing the end of the operating angle and Parallel Trim that moves the end of the operating angle and the neutral position simultaneously. Sub Trim that adjusts the neutral (center) position before fixing the servo horn is Parallel Trim and the main trim is Center Trim.

- Center Trim (Main Trim)

Even if you move the neutral position with Trim, the end of the operation angle does not move.



- Parallel Trim (Sub Trim)

When you move the neutral position with Trim, the end of the operation angle also moves. When Sub Trim is adjusted after linkage is completed, readjustment of End Point Adjustment (EPA) will be necessary.

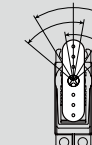

How to Use Each Feature

BASE

SETTING

- Base sets multiple functions all at once such as the Reverse that determines the direction of the servo of each channel, the speed controller according to a specific RC car, the Sub Trim that adjusts the neutral position, and the End Point Adjustment [EPA].

END POINT ADJUSTMENT [EPA]

- EPA setting can adjust left and right steering servo range for steering operation, high and brake throttle working range for throttle trigger operation, and the servo working range for AUX1, AUX2 (3ch, 4ch).

[ST-EPA] STEERING END POINT ADJUSTMENT

- Due to linkage, suspension balance and the difference of the tire diameter, left and right cornering radius can be different. In case of this, this feature adjusts the servo working range of left and right so that left and right cornering radius can be the same.

- 1) Before adjusting Steering End Point Adjustment (ST-EPA), make a neutral adjustment of the servo (P.22). Neutral adjustment is to align the center position with Sub Trim by turning the power on and installing the servo horn in the approximate center position.

- 2) Select either of [EPA-L/EPA-R] with up and down key. Determine with the Enter.

- 3) Adjust the working range with up and down key.

*When the cursor is on either of EPA-L/EPA-R, it is also possible to move the cursor by steering operation.

- Setting Range: L/R 0%~150%
- Default: L/R 100%

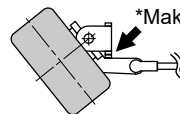

*Make sure the servos do not lock to make clicking sound

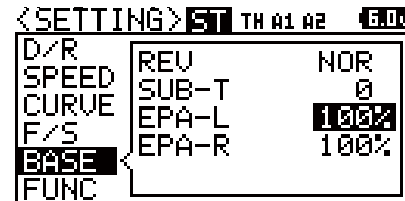

Note • If the linkage is locked for a long period, it can cause the servo breakage.

[TH-EPA] THROTTLE END POINT ADJUSTMENT

- It adjusts the High Point of FET Speed Controller, Brake Point, carburetor of engine and the brake working range.

- 1) For a nitro car, make a neutral adjustment of the servo (P.20) before adjusting the Throttle End Point Adjustment (TH-EPA).

Neutral adjustment is to align the center position with Sub Trim by turning the power on and installing the servo horn in the approximate center position.

- 2) Select [TH/Throttle] with up and down key.

- 3) Select either of [EPA-H/EPA-B] with up and down key. Determine with the Enter.

- 4) Adjust the operating quantity with up and down key. When adjusting ESC / FET Speed Controller, normally set both the high side and the brake side to 100% and set neutral, high point and brake point on the ESC / FET Speed Controller side (Setting method is different depending on the ESC / FET Speed Controller).

*When the cursor is on either of EPA-H/EPA-B, it is also possible to move the cursor by trigger operation.

- Setting Range: H/B 0%~150%
- Default: H/B 100%

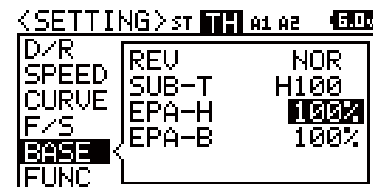

*Make sure the servos do not lock to make clicking sound

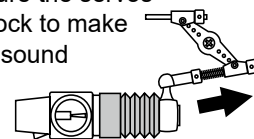

Note • When EPA setting value is too large on the fully open side of the carburetor and the brake side for throttle linkage, the servo is locked and it can cause the motor malfunction and runaway.

[AUX1-EPA]

AUX1 • END POINT ADJUSTMENT

- You can use AUX1 for functions of accessories and adjust the maximum steering angle with EPA. Since you can set H/L separately, precise adjustment is possible.

*When setting AUX1 to [CODE5/CODE10] in AUX TYPE, the operation will not be reflected even by adjusting EPA.

- 1) Before adjusting AUX1 End Point Adjustment (A1-EPA), make a neutral adjustment of the servo (P. 22). Neutral adjustment is to align the center position with SubTrim by turning the power on and installing the servo horn in the approximate center position.

- 2) Select [AUX1] with up and down key.

- 3) Select either of [EPA-H/EPA-L] with up and down key. Determine with the Enter.

- 4) Adjust the working range with up and down key.

- Setting Range: H/L 0%~150%
- Default: H/L 100%

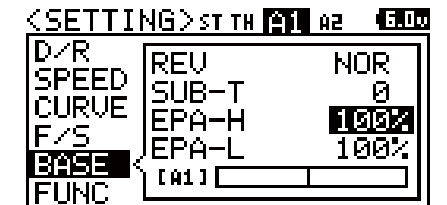

[AUX2-EPA]

AUX2 • END POINT ADJUSTMENT

- You can use AUX2 for functions of accessories and adjust the maximum steering angle with EPA. Since you can set H/L separately, precise adjustment is possible.

*When setting AUX2 to [CODE5/CODE10] in AUX TYPE, the operation will not be reflected even by adjusting EPA.

- 1) Before adjusting AUX2 End Point Adjustment (AUX2-EPA), make a neutral adjustment of the servo (P. 22). Neutral adjustment is to align the center position with Sub Trim by turning the power on and installing the servo horn in the approximate center position.

- 2) Select [AUX2] with up and down key.

- 4) Select either of [EPA-H/EPA-L] with up and down key. Determine with the Enter.

- 3) Adjust the working range with up and down key.

- Setting Range: H/L 0%~150%
- Default: H/L 100%

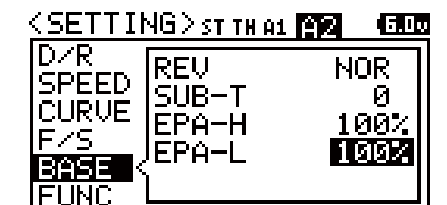

How to Use Each Feature

FUNCTION [FUNC]

SETTING

- Function can set trim, ALB (Anti-Lock Brake), OFFSET, and TH TYPE (Throttle Type) on each channel.

TRIM

- Correct neutral (center) of each channel (ST/TH/A1/A2) with Trim.
- As default, steering is set for Trim 1 (TRM1), and throttle for Trim 2 (TRM2).

- 1) Select a channel (ST/TH/AUX1/AUX2) for adjusting Trim with up and down key.
- 2) Determine with Enter operation and adjust with up and down key.

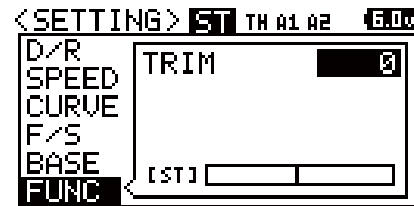

- Setting Range:
 - ST:L100~R100
 - TH:H100~B100
 - AUX1:H100~L100
 - AUX2:H100~L100

- Default: ALL : 0

*Make an adjustment with TRM1 (ST) and TRM2 (TH) during operation. You can change the Trim lever position with the Key Assignments Trim feature (P. 46).

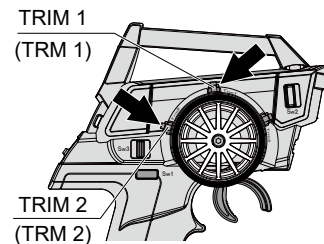

IMPORTANT

• About Trim

- Trim is a feature to adjust the neutral (center) position of the servos. After installing the steering servo onto a car, you can adjust with Trim when the car does not move straightly. Neutral position adjustment is necessary not only after installing the servo but for changes that happen during running such as tire wears and chassis twist.
- It's Sub Trim that adjusts the center position when adjusting linkage (P. 22)



Note

- If Trim and Sub Trim are off to one side, it causes dead band (the range the servo does not move) to the steering wheel and the throttle trigger. When installing the servo horn, fix the servo horn as close to the center as possible and center it with Sub Trim.

ANTI-LOCK BRAKE [ALB]

- Anti-Lock Brake enables stable braking on a low grip road.
- Because of the stable braking, you can drive ideal cornering lines as intended.

- 1) Select [ALB] with up and down key.
- 2) The menu changes to ALB setup menu with the enter operation.
- 3) Setting Stroke (STROKE)
 - Set Stroke of ALB with up and down key. Stroke is the width of repeated actions at the time of braking.
 - Setting Range: OFF, 0%~100%
 - Default: OFF *ALB does not work when it is off.
- 4) Setting Point (POINT)
 - Set Point of ALB with up and down key. Point is the position where ALB starts acting when operating the brake.
 - Setting Range: 5%~100%
 - Default: 80%

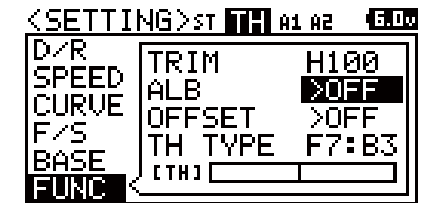

ENTER ↓ ↑ BACK

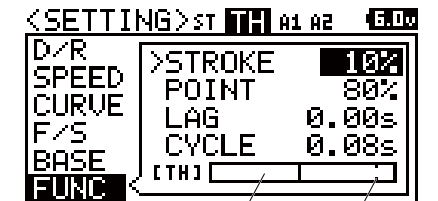

Trigger indicator

Point Position

[ALB will be worked when trigger operation is right side (Brake side)]

- 5) Setting Lag (LAG)
 - Set Lag of ALB with up and down key. Lag is a setting of time lag from the time when operating to the point to the time when ALB starts acting.
 - Setting Range: 0.00s~1.00s
 - Default: 0.00s
- 6) Setting Cycle (CYCLE)
 - Set a cycle of ALB with up and down key. Cycle is a frequency setting of repeated actions for braking.
 - Setting Range: 0.01s~1.00s
 - Default: 0.03s

*While Anti-Lock Brake working, transmitter LED will be high-speed flashing.

*LED flashing time and way of flashing are same in any setting values.

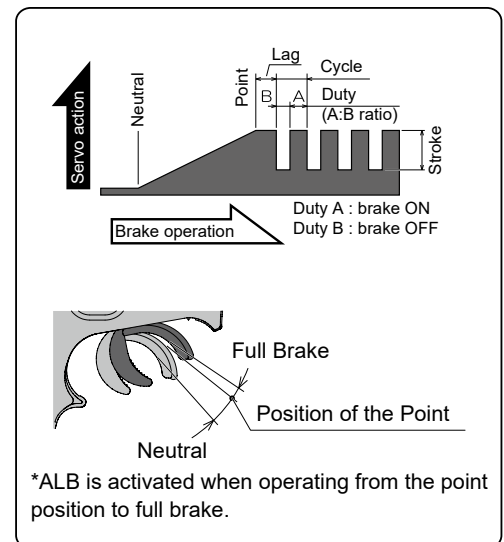

SUPPLEMENT

- Activate the brake rather strongly not to the extent that the tires of your RC car lose their grips (not to slip) and adjust so that Anti-Lock Brake is activated just before the tires are locked and slide.
- If you set ALB using a speed controller with a back on an RC car, you may not able to operate back movement. When using a back movement, turn ALB off.

How to Use Each Feature

FUNCTION [FUNC]

SETTING

- Function can set trim, ALB (Anti-Lock Brake), OFFSET, and TH TYPE (Throttle Type) on each channel.

OFF SET

- By moving the position of the throttle neutral at the time of starting a nitro RC car engine, it improves the start-up performance of the engine.
- You can fix at a position where idling speed is increased so that the engine will not stop during refueling your nitro RC car.
- By operating the switch that has been set, you can stop the engine of your RC boat.
- You can use various power sources with Offset feature.
- ON/OFF of the Offset can be assigned to the switch.

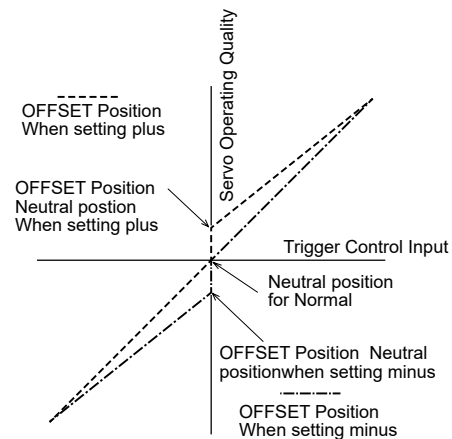

- 1) Select [OFFSET] with up and down key.
- 2) Determine with enter operation.
It will change to OFFSET Setting menu.
- 3) Setting Offset [OFFSET]
Set ON/OFF of the Offset feature with up and down key.
 - Setting Range: ON/OFF
 - Default: OFF
- 4) Setting Position [POS]
Set Position of the Offset with up and down key.
 - Setting Range: H100%~B100%
 - Default: 0%

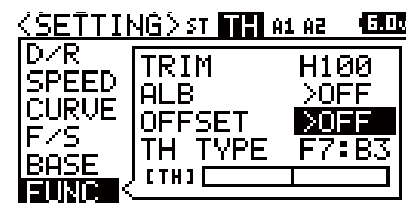

ENTER ↓ ↑ BACK

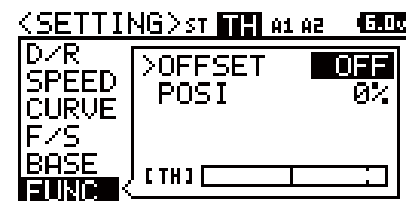

THROTTLE TYPE [TH TYPE]

- You can move the neutrals position of the throttle and set the operating ratio of the forward side and the brake (backward) side to either 7:3 or 5:5.

*Set the throttle type according to the speed controller to be used.

- 1) Select [TH TYPE] with up and down key.
- 2) Determine with enter operation.
It will change to TH TYPE Setting menu.
- 3) Setting the Throttle Type
Set the Throttle Type with up and down key.
 - Setting Range: F7:B3 / F5:B5
 - Default: F7:B3

*When changing TH TYPE, the screen changes to the confirmation screen and a message is displayed.
Operate following the message.

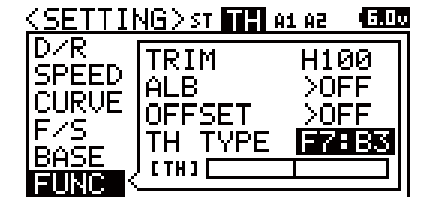

ENTER ↓ ↑ BACK

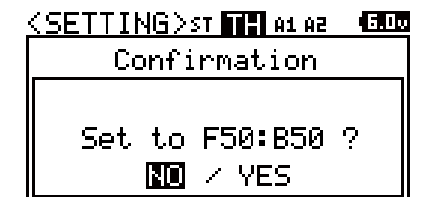

- NO →Cancel to Change Throttle Type
- YES →Confirm to Change Throttle Type

How to Use Each Feature

AUX

AUX

- AUX menu sets the performance of AUX1 and AUX2 (3ch, 4ch). You can choose from STEP AUX (STEP), POINT AUX (POINT), 4WS (4-Wheel Steering: Coordinate Phase, Opposite Phase). MOA (Motor On Axle), AUX-MIX (AUX Mixing: ST → AUX/TH-AUX) and CODE-AUX.

STEP AUX

- Setting Step AUX allows you to set the operating quantity by operating assigned Trim or a switch.
- By factory default, the AUX feature is set to the Step AUX.

- 1) Select [AUX] with up and down key.
- 2) Determine with enter operation.
It will change to CH Setting menu.
- 3) Setting Step AUX (STEP AUX)
Determine [CH] to activate with the enter.
Set the position of the motion with up and down key.

*Operating range also can be set by EPA (End Point Adjustment, P.24).

- Setting Range: H100% ~L100%
- Default: 0%

- 4) Mode Setting (MODE)
Determine with enter, and set working step values to the used method.

- Setting Range: 1/2/5/10/20/25/50/100
- Default: 5

SET can be AUX TYPE and MODE setting and shortcut of the key assign function.
*Assign the features to Trim and switch with Key Assignments according to the used method.

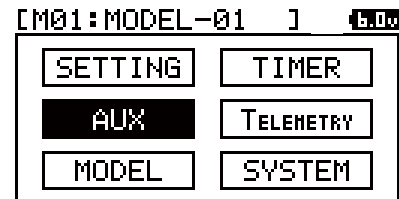
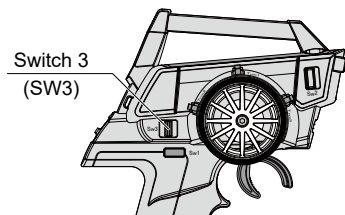

ENTER ↓ ↑ BACK

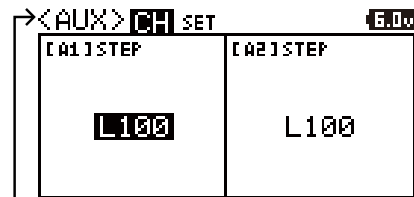

Switch CH to SET with up and down key.
Select CH with enter.

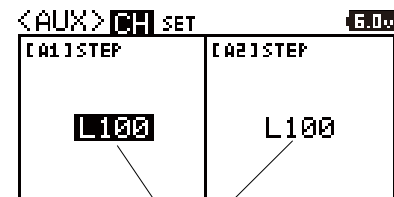

AUX1 Setting AUX2 Setting

Operation Position

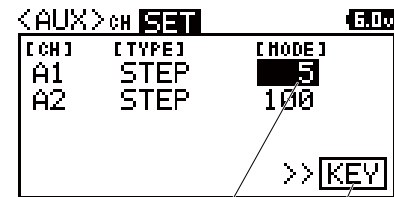

STEP Setting Shortcut for Key Assign

POINT AUX

- By setting Point AUX and assigning the movement of AUX1/AUX2 (3ch, 4ch) to the switch and Trim, you can move the servo to Point1, Point2, and Point3 position. The Point that moved can be set with EPA (End Point Adjustment). Adjust the Point position according to the usage.

*Point number is 3 point cannot change.

- 1) Select [AUX] with up and down key.
- 2) Change [SET] menu with enter.
*Switch CH to SET with up and down key.
- 3) Type Setting (POINT)
Select [POINT] on AUX TYPE with up and down key.
- 4) Point and setting values
Select A1 or A2 you want to set and enter.
Select 1, 2, or 3 you want to set and enter.
Set values with up and down key.

*AUX1 and AUX2 can be set AUX TYPE separately.

*Operating range also can be set by EPA (End Point Adjustment, P.24).

*Assign on SW3 or trim according to the used method.

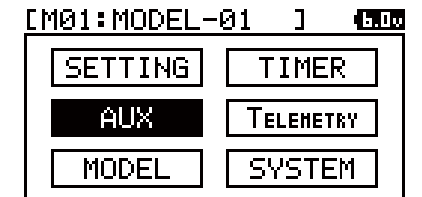

ENTER ↓ ↑ BACK

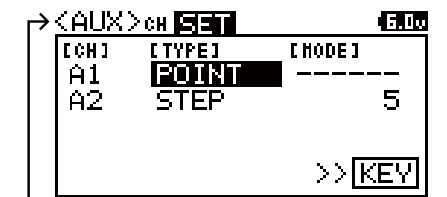

Switch CH to SET with up and down key.
Select SET with enter.

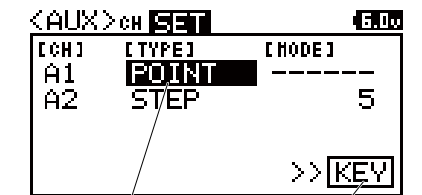

Switch Type Shortcut for Key Assign

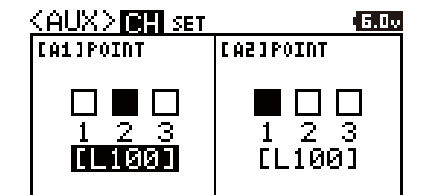
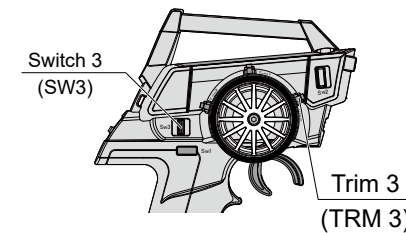

How to Use Each Feature

AUX

AUX

- AUX menu sets the performance of AUX1 and AUX2 (3ch, 4ch). You can choose from STEP AUX (STEP), POINT AUX (POINT), 4WS (4-Wheel Steering: Coordinate Phase, Opposite Phase). MOA (Motor On Axle), AUX-MIX (AUX Mixing: ST → AUX/TH-AUX) and CODE-AUX.

4-WHEEL STEERING [4WS]

- With the operation of assigned Trim or Switch, control the motion of the 4 Wheel Steering.

- 1) Select [AUX] with up and down key.
- 2) Change [SET] menu with enter.
*Switch CH to SET with up and down key.
- 2) Type setting (4WS)
Select [4WS] on AUX TYPE setting with up and down key.
- 4) Mode setting
Set 4WS working mode to used method.

- Setting Range: 2 mode / 3 mode/ 4 mode
- Default: 4 mode

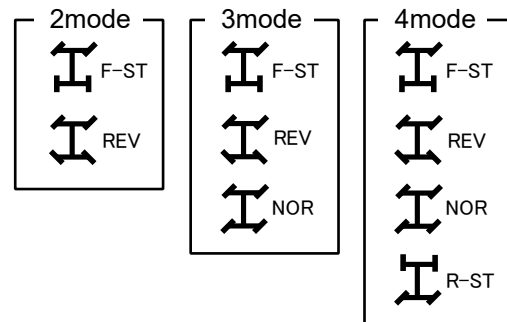

*Please refer the above picture for working mode.

- 5) Working mode setting
Enter working mode setting and change the mode with up and down key.
*In case of changing mode while driving, please assign workig mode on trim or switch.

- Setting range: F-ST / REV / NOR / R-ST

- * Switch working mode by mode setting on SET.
- * Rear steering servo will work on AUX 1 or AUX channel by setting 4WS.
- *Operating range can be set by EPA (End Point Adjustment, P.24).

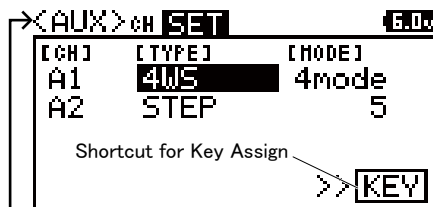
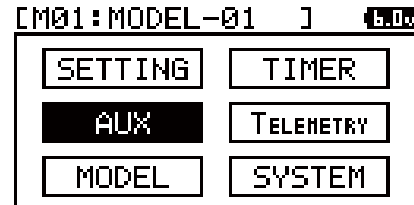

Switch CH to SET with up and down key.
Select SET with enter.

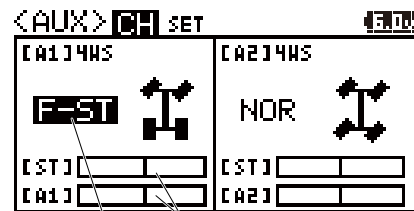

Servo Monitor
Switch Working Mode

Steering Working Image

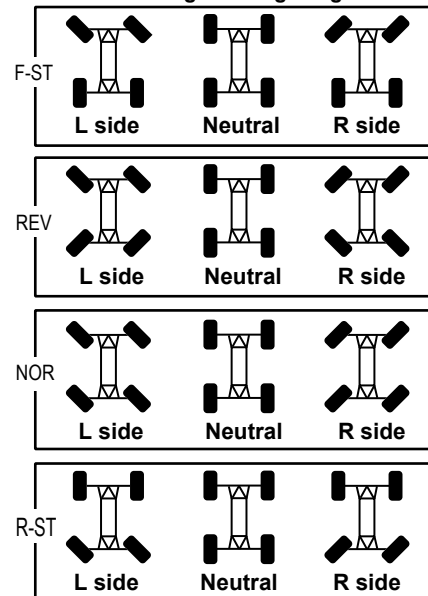

FRONT-REAR WHEEL SEPARATE DRIVE [MOA]

- By setting Motor On Axle (MOA), you can adjust the drive ratio of front and rear wheels of a front-rear dual motor car.

- 1) Select [AUX] with up and down key.
- 2) Change [SET] menu with enter.
- 3) TYPE setting (MOA)
Select [MOA] on AUX TYPE setting with up and down key.
- 4) MODE setting
Set MOA drive ratio to the used method.

Setting Range: 1/2/5/10/20/25/50/100
Default: 10

*Connect the speed controller for controlling the rear motor to the channel (AUX1/AUX2) that is set to MOA.

*When using, assign the features to switch or trim or operate with up and down key.

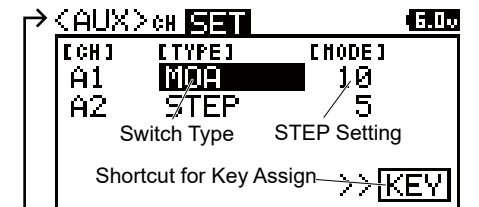
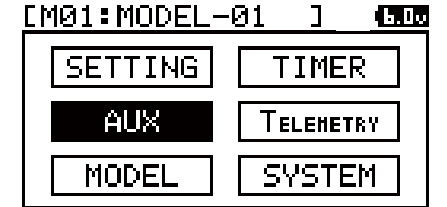

Switch CH to SET with up and down key.
Select SET with enter.

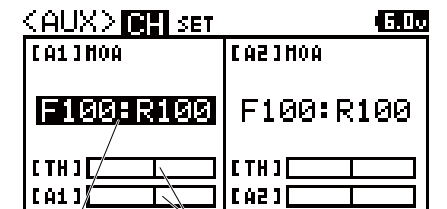

Servo Monitor
Front-Rear Drive Ratio

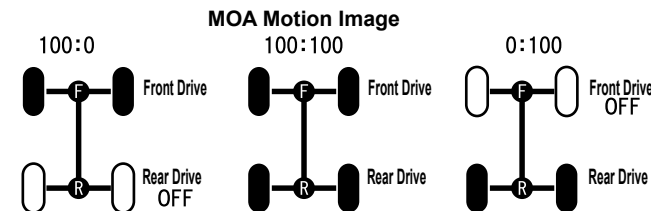

*By changing the ratio, you can adjust the gear ratio of front-rear.

How to Use Each Feature

AUX

AUX

- AUX menu sets the performance of AUX1 and AUX2 (3ch, 4ch). You can choose from STEP AUX (STEP), POINT AUX (POINT), 4WS (4-Wheel Steering: Coordinate Phase, Opposite Phase). MOA (Motor On Axle), AUX-MIX (AUX Mixing: ST → AUX/TH-AUX) and CODE-AUX.

AUX MIXING [AUX MIX]

- Setting AUX Mixing allows you to mix from the steering to AUX and from the throttle to AUX.

1) Select [AUX] with enter.

2) Change [SET] menu with enter.

*Switch CH to SET with up and down key.

3) TYPE setting (AUX-MIX)

Select [AUX-MIX] on AUX TYPE setting with up and down key.

4) MODE Setting

Set mixing mode to the used method.

○Setting Range: ST-mix / TH-mix

○Default: ST-mix

*ST-mix is mixed from the steering to AUX.

TH-mix is mixed from the throttle to AUX.

5) Mixing rate setting

Set mixing rate with up and down key.

○Setting Range: 0%~100%

○Default: 100%

*Assign the features of the Mixing Rate to Trim or the switch with Key Assignments, or operate with up and down key.

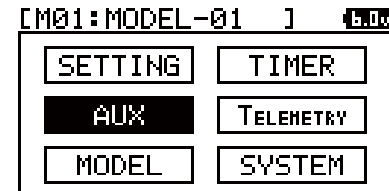

Switch CH to SET with up and down key.
Select SET with enter.

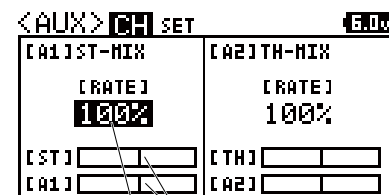

Servo Monitor
Mixing Rate Setting

CODE AUX

- Code AUX (CODE AUX) is a feature to perform code communication by assigning a setting value to each code of CODE1-CODE10.

It is an extension feature to change the setting of speed controller (SUPER VORTEX series/ SV-D2), PGS servo series, and the Gyro System (SGS-01C/SGS01D/SGS-02) that are compatible to CODE AUX.

- You can set 2 types of Code AUX1 and CODE AUX2.

*Please set response mode [SHR] on A1 and A2 when binding with a receiver. (p.43).

*In case of using CODE AUX, please do NOT connect servos on receiver CH3 and CH4 port.

1) Select [AUX] with up and down key.

2) Change [SET] setting menu with enter.

*Switch CH to SET with up and down key.

3) Type Setting (CODE AUX)

Select [CODE] on AUX TYPE setting with up and down key.

*CODE is only compatible with CODE10 products.

*MT-R is not compatible with CODE5 products such as

SV-ZERO, SV-SPORT, SV-TYPE D, SGS-01, and SGS-01D.

4) Mode setting

Display function name for CODE10 products by setting mode for compatible product.

○Setting Range: CODE/SV-G/D(only AUX1)

CODE/PGS/SGS-02 (only AUX2)

○Default: CODE

5) CODE AUX setting

Select CODE with enter you want.

Set value with up and down key.

*In case of setting CODE on AUX TYPE, CODE AUX setting condition will display on top screen as below pictures.

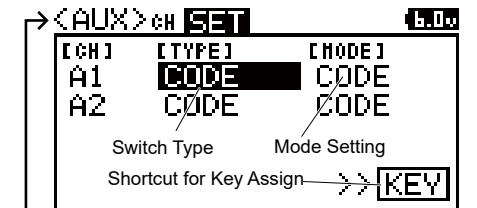
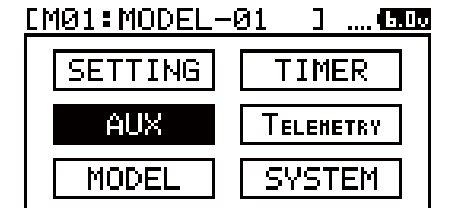

Switch CH to SET with up and down key.
Select SET with enter.

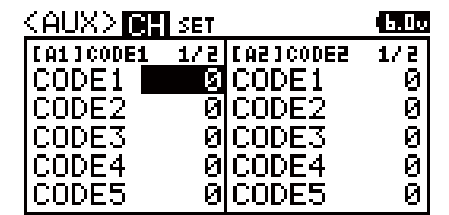

When Mode Setting is CODE 10

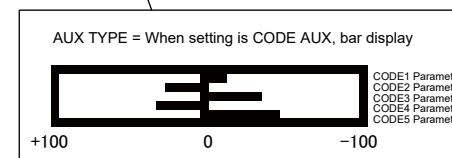
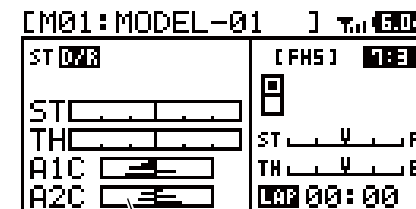

*CODE6~10 is not displayed on top display.
Please check display on the AUX menu.

How to Use Each Feature

MODEL MENU

MODEL

- You can set the features about Model Select, Model Name, Model Copy and Model Clear.
- Installed with high capacity EEPROM and it can memorize data for 20 models of M01 ~ M20.

MODEL SELECT

- You can call model data of memorized M01 ~ M20 easily.

- Select [MODEL] with up and down key. Determine with enter.
- Setting Model Select (MODEL SELECT) Select [MODEL SELECT] with up and down key. Determine with enter.
- Selecting Model Select Model to call with up and down key.
- Setting Range: M01 ~M20
- When moving the cursor to the model to call and Enter is being operated, a message is displayed on the screen. Follow the display to operate and select a model.

1. Model Display

2. Model Select

3. Confirmation

Model for Change

Select model you want to use

Confirm model you want to use

No: Back to 2.
Yes: Change Model and Back to 2.

MODEL NAME

- You can register a model name with up to 10 characters of alphabets, numbers, symbols, and Japanese Katakana for each model.

- Select [MODEL] with up and down key. Determine with the Enter operation.
- Setting Model Name [MODEL NAME] Select [MODEL NAME] with up and down key. Determine with the Enter operation.
- Setting Model Name Move the cursor "_____" with up and down key to the position to input texts. Once the position is determined, press the Enter key to determine the cursor position. "_____" is flashing when moving, and is turning on when determined.
- Select texts to enter with up and down key. Once the texts to enter are determined, enter with the Enter key.
 - Setting Range: A~Z, a~z, 0~9, Symbols, Space, Japanese Katakana, Little Katakana.
- Repeat 3) and 4), and enter texts.

Cursor for select word

Cursor position for select word (When moving cursor, the line will be flashed)

Alphabet lower cases

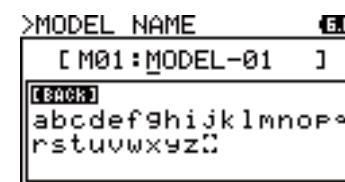

Number and Symbols

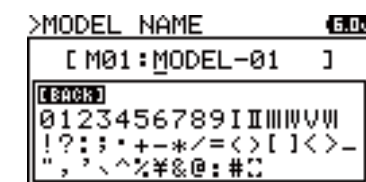

Japanese Katakana



Japanese Little Katakana



SUPPLEMENT

MT-R has a feature of Direct Model Select. When turning the power switch of the transmitter on while pressing the Back/Cancel button, it starts from the MODEL SELECT screen so that you can easily call a model to use.

How to Use Each Feature

MODEL MENU

MODEL

- You can set the features about Model Select, Model Name, Model Copy and Model Clear.
- Installed with high capacity EEPROM and it can memorize data for 20 models of M01 ~ M20.

MODEL COPY

- You can copy a selected model data to another model.

- 1) Select [MODEL] with up and down key
Determine with the Enter operation.
- 2) Setting Model Copy [MODEL COPY]
Select [MODEL COPY] with up and down key.
Determine with the Enter operation.
- 3) Selection of a Copy Destination Model
Select a Copy Destination Model with up and down key.
*Model for copy is model date is current using model.
- 4) When Enter is being operated a message is displayed on the screen. Follow the display to operate and complete Model Copy.

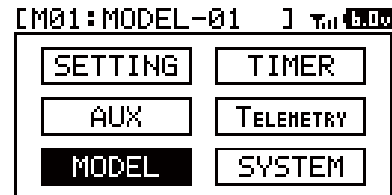

ENTER ↓ ↑ BACK

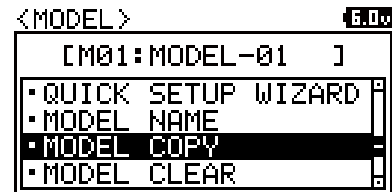

ENTER ↓ ↑ BACK

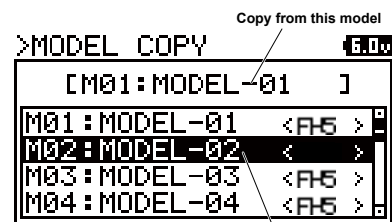

1. Select Copy Model

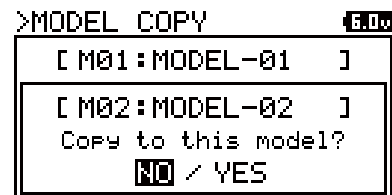

2. Confirm to Copy

NO: Back to 1.
YES: Move to 3.

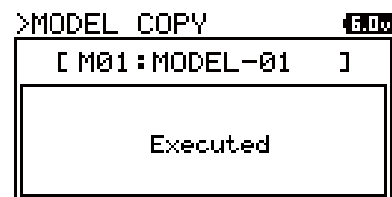

3. Executed

Back to 1. after completed

MODEL CLEAR

- A feature to clear (initialize) the setting data of Models.

- 1) Select [MODEL] with up and down key.
Determine with the Enter operation.
- 2) Setting Model Clear [MODEL CLEAR]
Select [MODEL CLEAR] with up and down key.
Determine with the Enter operation.
- 3) When Enter is being operated, a message is displayed on the screen. Follow the display to operate and complete Model Clear.

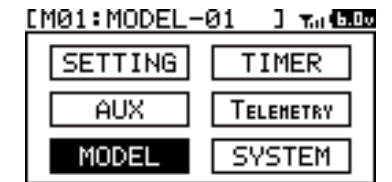

ENTER ↓ ↑ BACK

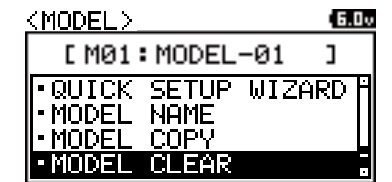

ENTER ↓ ↑ BACK

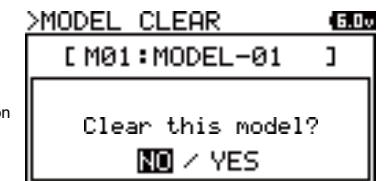

1. Confirmation

NO: Back to Model Display
YES: Move to 2.

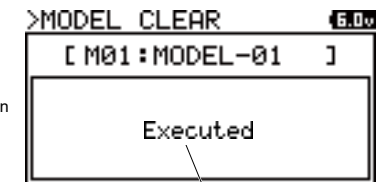

2. Clear Completion

After flashing twice,
Back to model display

How to Use Each Feature

TIMER MENU

TIMER

- It has three timer features including Lap Timer, Interval Timer and Down Timer.
- When selecting a timer and operate the up and down key, you can toggle between the timer screen and the setting screen.

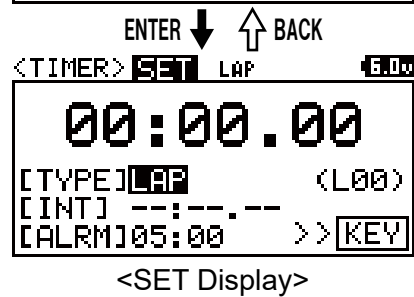
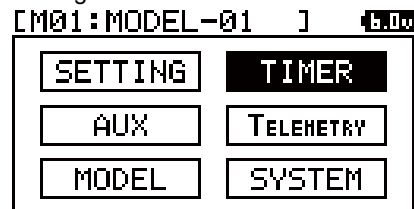

UP Key
Down Key

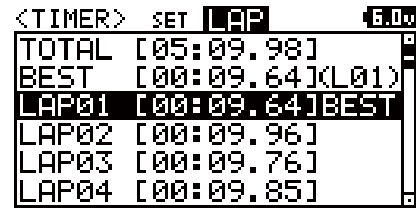

- Lap display can be checked measured lap time.
- Select Lap with up and down key during stopping lap timer.
- *The fastest lap in the measured lap time will be shown [BEST].

INTERVAL TIME [INT TIMER]

- It activates the alarm at the time set at the beginning of running and uses it as the guideline for the lap time.

- 1) Select [TIMER] with up and down key. Determine with the Enter operation.
- 2) Change [SET] menu with enter.
*Switch SET to LAP with up and down key.
- 3) Setting the Type [TYPE]
Select [INT] with up and down key. Determine with enter.
- 4) Setting Interval (INTERVAL)
Set the Interval Timer.
○ Setting Range: 00:00.01 ~ 99:59.99
○ Default: 00:00.00
*Interval timer will not work for 00:00.00.

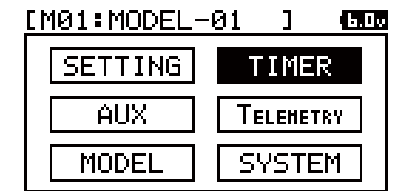

ENTER ↓ ↑ BACK

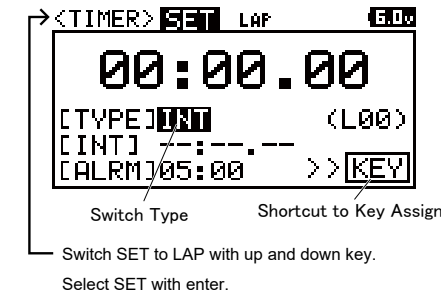

- 5) As the default, timer swith is set on SW1.
Holding SW1 will standby timer.
Then when push SW1 again or operating throttle, timer will be started.
- 6) After starting timer, lap timer will be reset when pushing SW1.
- 7) Completing measuring
By holding SW1, measuring will be completed.
After finished goal time, pushing SW1 will be lap timer reset.
*When turning the power switch off while the timer is activated, the timer will be reset.
*When the timer is set to SW1, the timer will be in the standby mode by holding the switch even on a screen other than the TIMER setting screen.

LAP TIMER

- You can measure and record each lap up to 99 laps (works for all models).
- Pre Alarm (PRE-ALM) is installed and the alarm goes off before the goal.

- 1) Select [TIMER] with up and down key. Determine with the Enter operation.
- 2) Change [SET] menu with enter.
*Switch SET to LAP with up and down key.
- 3) TYPE setting
Change [LAP] on TYPE setting with up and down key.
Determine with enter.

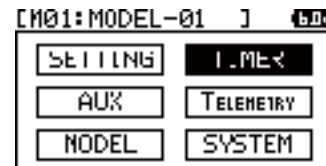

ENTER ↓ ↑ BACK

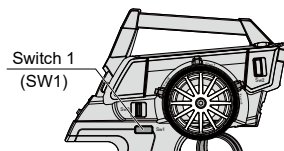
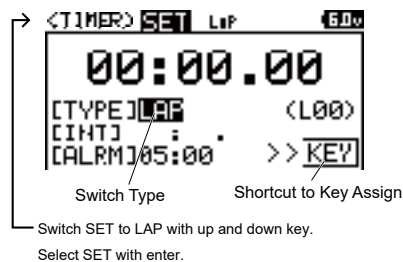

- 4) Goal Time setting
Set goal time [ALRM] with up and down key.
○ Setting Range: 00:01 ~ 99:59 (unit: 00:01 each)
○ Default: 05:00
- 5) As the default, timer swith is set on SW1.
Holding SW1 will standby timer.
Then when push SW1 again or operating throttle, timer will be started.
- 6) After starting timer, lap time is recorded when pushing SW1.
After pushing SW1, the switch will not work while 3 seconds.
- 7) Completing measuring
By holding SW1, measuring will be completed.
Or pushing SW1 after finished goal time will complete measuring.

*When turning the power switch off while the timer is activated, the timer will be reset.

*When the timer is set to SW1, the timer will be in the standby mode by holding the switch even on a screen other than the TIMER setting screen.

DOWN TIMER

- It can be for calculating running time of an electric RC car and the fuel consumption of an engine RC car.
- You can set for per second up to 99 : 59.
- When the timer switches to Up Timer after Down Timer ends, you can check lap time after the end.

- 1) Select [TIMER] with up and down key. Determine with the Enter operation.
- 2) Change [SET] menu with enter.
*Switch SET to LAP with up and down key.
- 3) Setting the Type [TYPE]
Select [DOWN] with up and down key. Determine with enter.

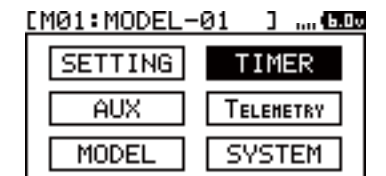

ENTER ↓ ↑ BACK

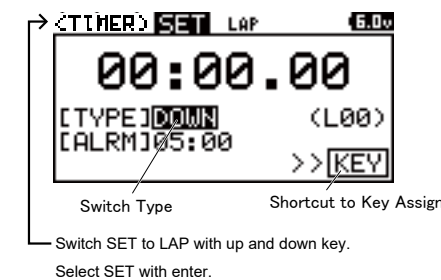

- 4) Set the Interval Timer.
○ Setting Range: 00:01 ~ 99:59
○ Default: 05:00
*Down timer will work as up timer for 00:00.
- 5) As the default, timer swith is set on SW1.
Holding SW1 will standby timer.
Then when push SW1 again or operating throttle, timer will be started.
- 6) After starting timer, down timer will be reset when pushing SW1.
- 7) Completing measuring
By holding SW1, measuring will be completed.
*When turning the power switch off while the timer is activated, the timer will be reset.
*When the timer is set to SW1, the timer will be in the standbymode by holding the switch even on a screen other than the setting screen.

How to Use Each Feature

TELEMETRY MENU

TELEMETRY

- A menu for setting Telemetry-related LOGGER, ALERT SETTING, TELEMETRY SETTING.
- To use the Telemetry, you can check with a compatible device such as SUPER VORTEX series.
- With Telemetry, you can check the data of 2 line of temperature, battery voltage and number of rotations with the transmitter.

•LOGGER:Check 2 line of temperature, battery voltage and number of rotations

•ALERT SETTING:Alert by setting temperature and battery voltage

•TELEMETRY SETTING:Various settings of Telemetry features

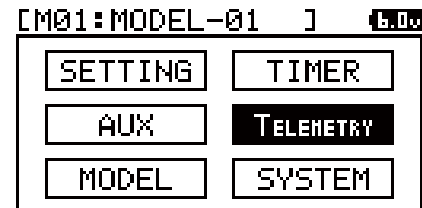

LOGGER

- Transmitter enables to record 2 temperatures (T1/T2) as battery, engine, and motor receiver voltage, engine or motor rotation number (PRM) with compatible receiver and Super Vortex series.
- Record (Log) setting can be set LOG STEP on the TELEMETRY SETTING (p.42). Log data interval is 0.1 ~ 45.9 seconds.
- Record (Log) can be 120 STEP (Min 12 seconds ~ Max 90 minutes).
- Logger working can be started by holding enter on each [LOGGER] display (T1/T2/VOLT/RPM) or assigned switch.

- 1) Select [TELEMETRY] with up and down key. Determine with enter.
- 2) Select [LOGGER] with up and down key. Determine with enter.
- 3) Select data for display [T1/T2/VOLT/RPM] with up and down key. Determine with enter. Check log data with up and down key.

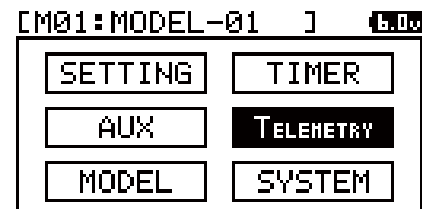

ENTER ↓ ↑ BACK

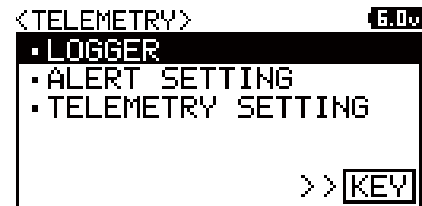

ENTER ↓ ↑ BACK

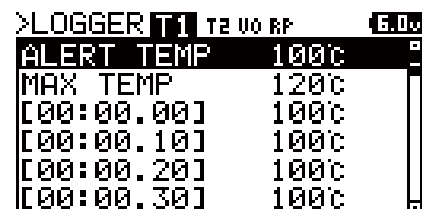

ALERT SETTING

- Alert setting is alerting by setting temperature and voltage. Also, transmitter blue LED will flash by setting telemetry data.

- 1) Select [TELEMETRY] with up and down key. Determine with enter.
- 2) Select [ALERT SETTING] with up and down key. Determine with enter.
- 3) T1 ALERT SETTING
Select [T1 ALERT] with up and down key. Determine with enter.
 - Setting Range: 0~150°C(32~302°F)
 - Default: 100°C(212°F)
- 4) T2 ALERT SETTING
Select [T2 ALERT] with up and down key. Determine with enter.
 - Setting Range: 0~150°C(32~302°F)
 - Default: 100°C(212°F)
- 5) VOLT ALERT Setting
Select [VOLT ALERT] with up and down key. Determine with enter.
 - Setting Range: 3.0V ~ 9.0V
 - Default: 3.8V
- 5) HOLD TIME Setting
*Sudden throttle work might be caused to instant voltage drop and it might lead unnecessary alert. In this situation, the HOLD TIME setting can make time to prevent from the unnecessary alert and provide stable alert for the unusual situation.
 - Setting Range: 0.0~5.0 sec
 - Default: 1.0 sec

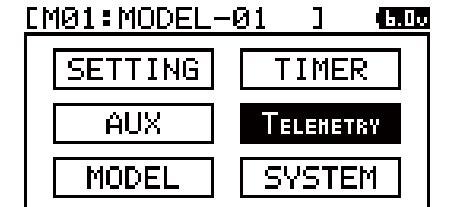

ENTER ↓ ↑ BACK

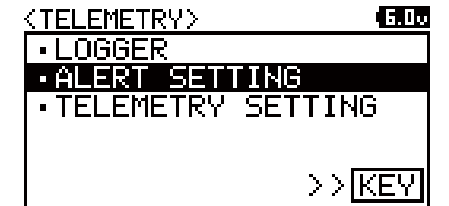

ENTER ↓ ↑ BACK

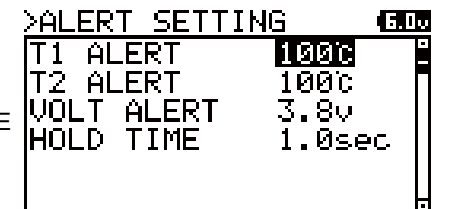

TELEMETRY SETTING

- Set each feature of Telemetry.
- 1) Select [TELEMETRY] with up and down key. Determine with enter.
 - 2) Select [ALERT SETTING] with up and down key. Determine with enter.
 - 3) TELEMETRY ON/OFF SETTING
Select [ON/OFF] with up and down key. Determine with enter.
 - Setting Range: ON/OFF
 - Default: ON
 - 4) LOG STEP SETTING
Select [LOG STEP] with up and down key. Determine with enter.
 - Setting Range: 00.1 ~ 45.9s
 - Default: 00.1s
 - 5) T1/T2 UNIT SETTING (Temperature unit setting)
Select [T1/T2 UNIT] with up and down key. Determine with enter.
 - Setting Range: °C/°F
 - Default: °C
 - 6) RPM RATIO SETTING
*When setting RATIO RPM sensor in the subtracted position, you can display the number of rotations of the motor and engine after back calculation with RATIO setting.
 - Setting Range: 00.001~64.999
 - Default: 01.000

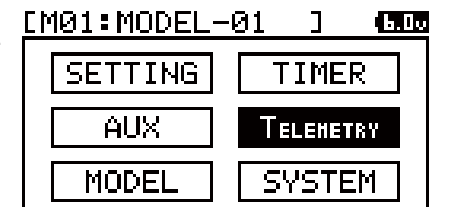

ENTER ↓ ↑ BACK

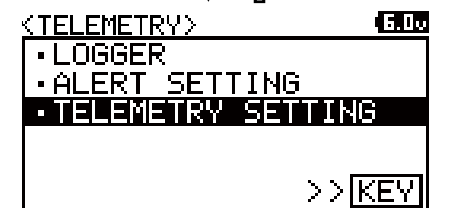

ENTER ↓ ↑ BACK

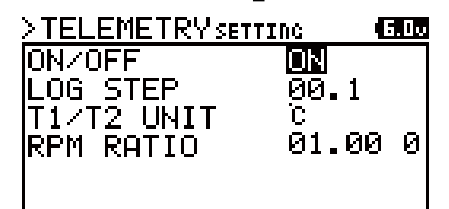

How to Use Each Feature

SYSTEM MENU

SYSTEM

- A feature for setting system of the transmitter, such as Bind, Key Assignments (KEY ASSIGN), Buzzer, Battery, LCD and CALIBRATION.

BIND

- Select the output system that suits the receiver, set a mode for the servo (analog/digital) and the speed controller to be used and bind the transmitter with the receiver. When using first time, please bind with receiver.

*MT-R does not bind with RX-493i of the factory.

- 1) Select [SYSTEM] with the up and down key. Determine with the Enter operation.

- 2) Select [BIND] with up and down. Determine with the Enter operation.

- 3) Setting RF MODE (Signal output system)

- Output System

• FH5

RX-491, RX-492, RX-493, RX-493i

*FH4, FH3, FH-E, DS mode receivers are not compatible.

- 4) Setting Channel Mode

Set the response mode for each channel with up and down key.

• You can set the response mode for each channel.

- Setting Range: NOR (Normal)

SHR (High Response)

SSR (Super Response)

SUR (Ultra Response)

- Default: NOR

[M01:MODEL-01] 6.0v

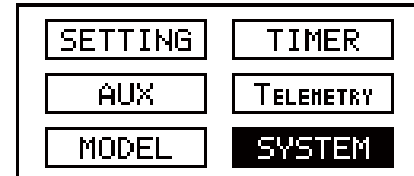

ENTER ↓ ↑ BACK

<SYSTEM> 6.0v

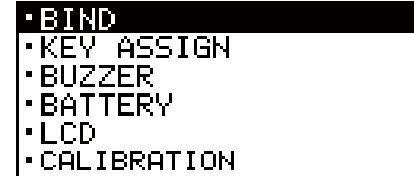

ENTER ↓ ↑ BACK

<BIND> 6.0v

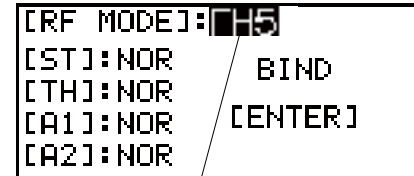

Output System

<BIND> 6.0v

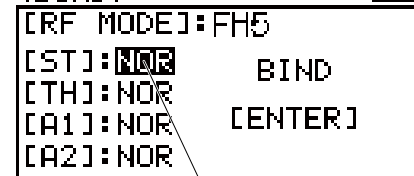

Response Mode

- 7) Setting BIND

- What is BIND: Each of MT-R transmitters has its own unique ID (solid identification) number. BIND is to let the receiver memorize the ID number. Operation will be possible only between the transmitter and the receiver that completed Binding.

- 1) When setting in the BIND menu is done, set BIND with up, down, and enter key.

- 2) Move the cursor to [ENTER] in the BIND menu and operate Enter. The transmitter now is ready for BIND operation.

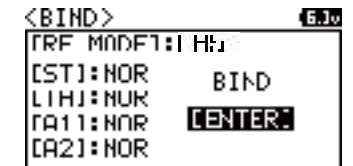
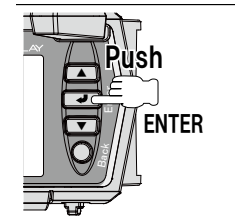

ENTER ↓

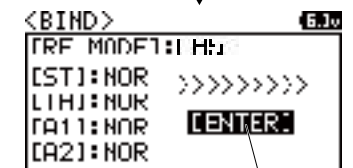

Status of the Receiver LED Flashing

- 3) Turn on the receiver with inserting Bind Plug in BIND/SSL port.

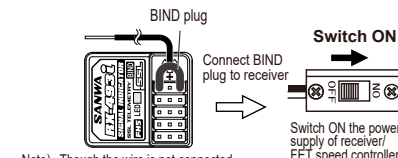

Note) Though the wire is not connected to the above-mentioned receiver, keep the servo and FET speed controller (excluding motor), battery in connected state.

- 4) When BINDING is done properly, the LED of the receiver starts flashing slowly at first then it flashes in high speed.

When the LED of the receiver flashes in high speed, operate the Enter key of the transmitter to complete BINDING.

Then, please take off the Bind Plug from the receiver.

When BINDING is done properly, the LED of the receiver is lit.

When the LED of the receiver is lit, please check the bind completion by using servo operation.

*When BINDING cannot be done properly, restart from step 2).

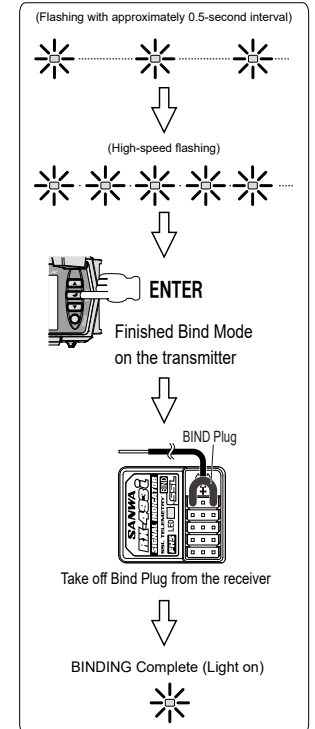

IMPORTANT

- Note that, in SHR/SSR/SUR mode, an analog servo will not work. If you mistakenly use an analog servo in SHR/SSR/SUR mode, it will not operate normally and the servo will be broken. Do not use an analog servo in SHR/SSR/SUR mode. For digital servo (SRG, ERB ERS series, Digital ERG series), it can work for either mode of NOR/SHR.
- SSR mode works only for PGS, SRG servo, SUPER VORTEX series, HV-12 STOCK SPECIAL and HV-01.
- SUR mode works for only PGS servo, SUPER VORTEX Gen2 / PRO / SV-D2.
- In SHR/SSR mode, BL/RACER, BL/FORCE, F2000, F2200, F3000, F3300, SBL-01, 02 and 03CL do not work.
- BL-SIGMA, SV-08, HV-10, HV-12 and F2500 work in NOR/SHR mode.

Note

- BINDING is not done at the factory. Please make sure to complete BINDING before use.
- When the receiver is new, make sure to complete BINDING for the transmitter and the new receiver.
- Make sure to use the set of the transmitter and the receiver that completed BINDING.
- When changing the setting in the BIND menu after BINDING, repeat BINDING.
- When changing the setting of the mode (NOR/SHR/SSR/SUR) after BINDING, repeat BINDING. If you do not re-BIND, setting changes will not be reflected.

How to Use Each Feature

SYSTEM MENU

SYSTEM

- A feature for setting system of the transmitter, such as Bind, Key Assignments (KEY ASSIGN), Buzzer, Battery, LCD and CALIBRATION.
- Switch and Trim position

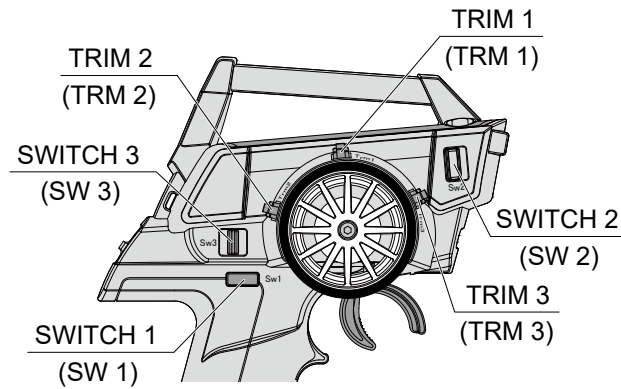

Features assigned to the Switch and Trim at the factory
 TR1: Steering Trim(TRM-ST)
 TR2: Throttle Trim(TRM-TH)
 TR3: Dual Rate ST(D/R-ST)
 SW1: TIMER
 SW2: AUX1
 SW3: AUX2

KEY ASSIGN SWITCH

- You can assign features to the switches (SW1, SW2, SW3) of the transmitter and toggle ON/OFF of the features during operation.

- 1) Select [SYSTEM] with up and down key.
Determine with the Enter operation.
- 2) Select [KEY ASSIGN] with up and down key.
Determine with the Enter operation.
- 3) Setting the Switch (SW1/SW2/SW3)
Operate the Enter with [SW] and set the feature to assign to the switch with up and down key.

- Setting Range:

Switch	Assignable Futures
SW1	OFF, ASIST-ST, D/R-ST, D/R-TH, D/R-BR, CUR-ST, CUR-TH, SPD-ST, SPD-TH, ALB, OFFSET, AUX1, AUX2, TIMER, TE-CLR, LOGGER

Switch	Assignable Futures
SW2	OFF, ASIST-ST, D/R-ST, D/R-TH, D/R-BR, CUR-ST, CUR-TH, SPD-ST, SPD-TH, ALB, OFFSET, AUX1, AUX2

Switch	Assignable Futures
SW3	OFF, D/R-ST, D/R-TH, D/R-BR, CU-R-ST, CU-R-TH, CU-R-BR, SP-ST-F, SP-ST-R, SP-TH-F, SP-TH-R, ALB-ST, ALB-LG, ALB-CY, OFFSET, AUX1(CD1~10), AUX2(CD1~10)

- Default : SW1: TIMER SW2: OFF SW3: OFF

*BY Setting [ASSIST-ST] onto SW1 and SW2, you can turn ON/OFF the feature of D/R, SPEED and CURVE that can be set onto the steering.

4) Setting Mode

It sets the switch performance but there are cases that you cannot set depending on the feature to assign.

- Setting Range

TOGGLE (Switching between ON/OFF when pressed every time)
 PUSH (ON is worked when switch is only pressed)

[M01:MODEL-01] Trm 6.00



ENTER ↓ ↑ BACK

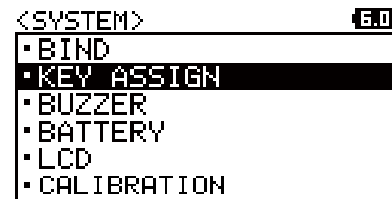

ENTER ↓ ↑ BACK

>KEY ASSIGN SW TRM 6.00

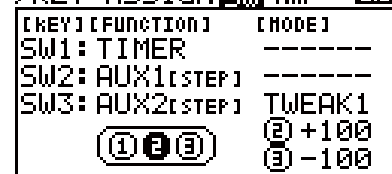

About MODE Setting for SW3

	①	②	③
TWEAK1	Neutral	P1	P2
TWEAK2	P1	Neutral	P2

P1/P2 can be changed freely.

KEY ASSIGN TRIM

- You can change the setting value of each feature with Trim1 - Trim3.
- You can also change the setting of the variation change in one time of Trim operation with the STEP setting and the direction of the action with the REV setting.

- 1) Select [SYSTEM] with up and down key.
Determine with the Enter operation.
 - 2) Select [KEY ASSIGN] with up and down key.
Determine with the Enter operation.
 - 3) Setting Trim (TRM1/TRM2/TRM3)
Select [TRIM] with enter. Change the setting and set a feature to assign with up and down key.
- Setting Range:

[KEY]	[FUNCTION]	[STEP]	[REV]
TR1	TRM-ST	5	NOR
TR2	TRM-TH	5	NOR
TR3	D/R-ST	1	NOR

Switch	Assignable Futures
TRIM1	OFF, TRIM-ST, TRM-TH, TRIM-A1, TRIM-A2, D/R-ST, D/R-TH, D/R-BR, CU-R-ST, CU-R-TH, CU-R-BR,
TRIM2	SP-ST-F, SP-ST-R, SP-TH-F, SP-TH-R, ALB-PO, ALB-ST, ALB-LG, ALB-CY, OFFSET,
TRIM3	AUX1(CD1~10), AUX2(CD1~10)

- Default: TR1:TRM-ST
TR2:TRM-TH
TR3:D/R-ST

4) Setting Step

Set the variation of the movement by one-time Trim operation.

Select [STEP] with up and down key. Determine with the Enter operation and set the variation.

- Setting Range: 1~100
- Default: 5

5) Setting the Direction of Action

Set the direction of action when operating Trim. Select [REV] with up and down key.

Determine with the Enter operation and set the direction of action.

- Setting Range: NOR/REV
- Default: NOR

How to Use Each Feature

SYSTEM MENU

SYSTEM

BUZZER

- You can set operating sounds of key operation, Trim and Switch and the buzzer tones.
- You can set 5 steps of the volume and 7 types of tones.

- Select [SYSTEM] with up and down key. Determine with the Enter operation.
 - Select [BUZZER] with up and down key. Determine with the Enter operation.
 - Setting Tone and Volume
You can switch between Tone (scales) and Volume (Sound Volume) with up and down key. Select an item to change setting to adjust.
- Setting Range: VOLUME OFF~5
TONE 1~7
 - Default: VOLUME 4
TONE 1

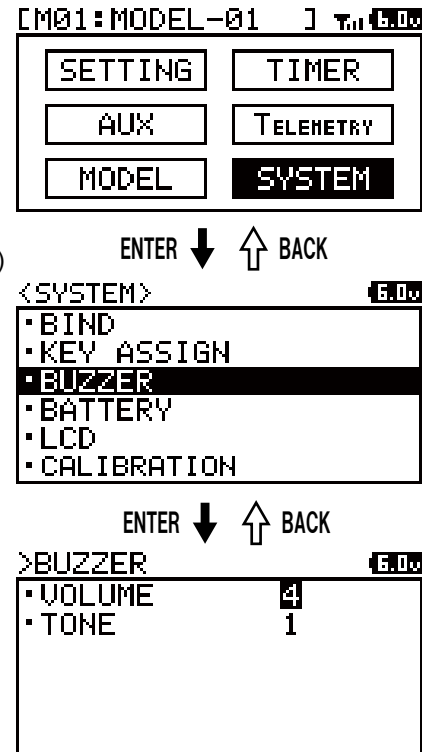

BATTERY

- You can change the voltage setting of the battery alarm of the transmitter.
- By selecting Type [DRYx4 (Batteries)/Ni-MH x4 (Nickel Metal Hydride)/Li-Fe x2 (Lithium Ferrite) /Li-Po x2 (Lithium Polymer),CUSTOM], you can set the alarm easily.
*When selecting CUSTOM with the Type, you can set ALERT VOLT that sets voltage to make Alarm go off and LIMIT VOLT of the lower limite voltage.

- Select [SYSTEM] with up and down key. Determine with the Enter operation.
 - Select [BATTERY] with up and down key. Determine with the Enter operation.
 - Setting TYPE
Set TYPE for the battery to be used with up and down key.
- Setting Range: DRY x4 (AA x4)
Ni-MH x2 (Nickel Metal Hydride)
Li-Po x2 (Lithium Polymer)
Li-Fe x2 (Lithium Ferrite)
CUSTOM: ALERT VOLT:4.1 ~ 9.0v
: LIMIT VOLT:4.0 ~ 9.0v
 - Default: DRYx4 (AA x4)

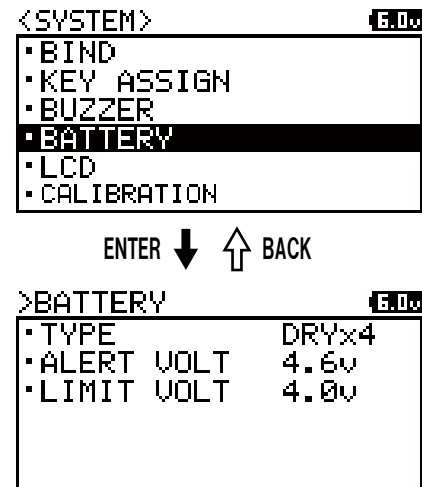

LCD

- You can set LCD contrast (intensity) and lighting mode of Back Light.
- Select [SYSTEM] with up and down key. Determine with the Enter operation.
 - Select [LCD] with up and down key. Determine with the Enter operation.
 - Set LCD contrast (intensity), lighting mode of Back Light, and language.

- Setting Items: CONTRAST (Intensity of Display)
LIGHTS-MODE (Backlight Lighting Mode)
LIGHT-TIME (Backlight Lighting Time)
- Setting Range: CONTRAST:0~30
LIGHT-MODE:OFF /KEY-ON /ALWAYS
LIGHT-TIME:1~30sec
- Default: CONTRAST:15
LIGHT-MODE:KEY-ON
LIGHT-TIME:10sec

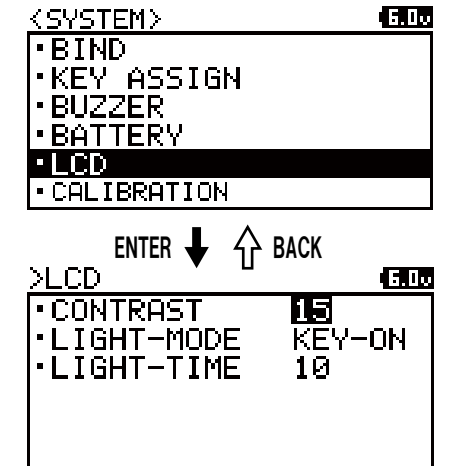

CALIBRATION

- Due to wearing and tearing of the internal mechanical elements over the usage time, the neutral position and the operation angle might become off. In such case, you can correct the neutral positions and the operation angle of the steering and the throttle.

- Select [SYSTEM] with up and down key. Determine with the Enter operation.
 - Select [CALIBRATION] with up and down key. Determine with the Enter operation.
 - Select a channel to calibrate with up and down key. Determine with the Enter operation.
 - When selecting [STEERING], operate the Enter with the steering wheel in neutral, then operate the steering wheel fully to left and right.
 - When entering the range, [OK] is displayed. Operate following the display.
 - When calibration is done, [Executed] is displayed.
- *If the throttle side also needs calibration, refer to the steering to set.



SUPPLEMENT

- Steering did not work correctly even if you did calibration. Please contact with our distributor in your country.

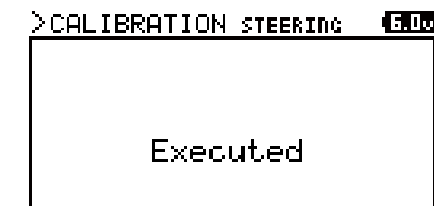

Completed Calibration

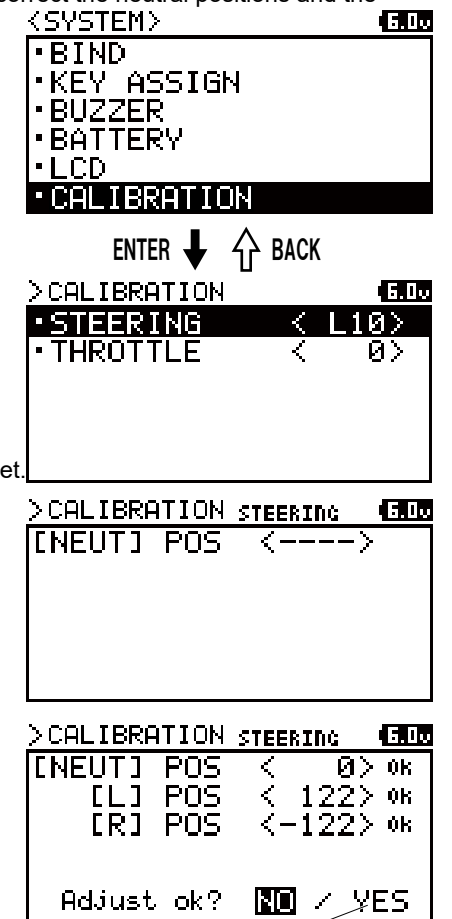

← YES

Select YES if calibration is OK

How to Use Each Feature

QUICK SETUP WIZARD

- Quick Setup Wizard function is easily to set up when you set up new RC car.
- Setup Wizard is following start menu→model select→type select→model initialize→RF mode select→response mode select→bind→base setting.

1) Turn the power switch on with holding enter key.

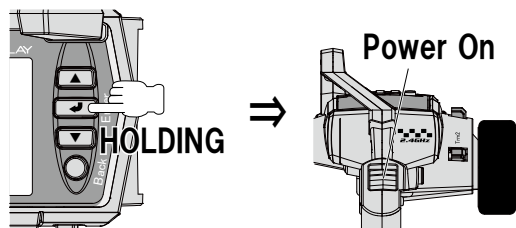

2) Quick Setup screen is displayed. Setup Wizard will be started with Enter.

3) Switch model select, and select model with up and down key. Determined car type with enter.

4) When the screen is changed to Car Type selection screen, select a Car Type using Multi-Selector. When a Car Type is selected, set with Enter.

Setting up Type

○ Setting Range:

- EP CAR STANDARD
- EP CAR DRIFT
- EP CAR (PGS)
- EP CAR (SV-G2P)
- EP CAR (SV-D2)
- GP CAR STANDARD
- 1/5 GP CAR DUAL BR1
- 1/5 GP CAR DUAL BR2
- CRAWLER 4WS/MOA

○ Default:

- EP CAR STANDARD

*Channel operation of each type will be as follows.

TYPE Lists

TYPE CH	EP CAR STANDARD	EP CAR (DRIFT)	EP CAR (PGS)	EP CAR (SV-G2P)	EP CAR (SV-D2)	GP CAR STANDARD	1/5 GP DUAL-BR1	1/5 GP DUAL-BR2	CRAWLER 4WS/MOA
CH1	STEERING	STEERING	STEERING	STEERING	STEERING	STEERING	STEERING 1	STEERING	STEERING F
CH2	ESC	ESC	ESC	ESC	ESC	THROTTLE /BRAKE	THROTTLE /BRAKE R	THROTTLE	ESC F
CH3	AUX1	AUX1	CODE1	CODE1	CODE1	AUX1	STEERING 2	BRAKE R	STEERING R
CH4	AUX2	AUX2	CODE2	CODE2	CODE2	CODE2	BRAKE F	BRAKE F	ESC R

*Select a type to be used according to an R/C.

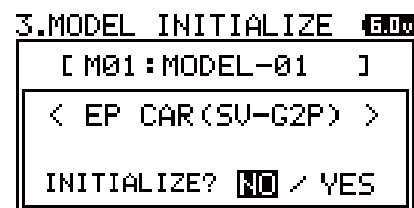
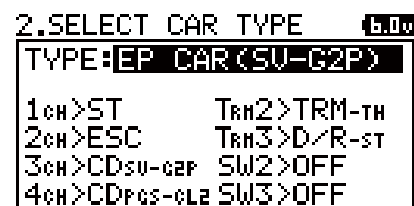
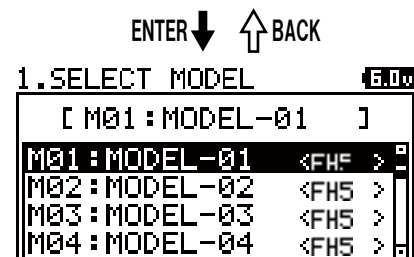

5) When deciding the car type using Enter, the screen changes to Initialization (Model Initialization) screen. Do initialization following the message.

6) When initializing (Initializing Model) is completed, the screen changes to RF Mode Selection Screen. MT-R is only compatible FH5 RF mode.

○ Default: FH5

• Compatible Receivers: FH5

RX-491, RX-492, RX-492i RX-493, RX-493i

7) Once RF Mode for the receiver is determined, the screen changes to the Response Mode screen. Set Response Mode according to the servos and the equipment to be used.

Set with up and down key and finalize with the Enter key.

○ Setting Range: NOR (Normal / Analog Servo)

SHR (High Response / Digital Servo)

SSR (Super Response / SRG Servo)

SUR (Ultra Response / PGS Servo)

○ Default: NOR (Normal / Analog Servo)

8) When Response Mode setting is completed, the screen changes to BIND Set up Screen. Follow the screen message and start Binding.

9) When Binding (BIND) is done, the screen changes to the Base Set Up screen. Complete setting for each channel (refer to p.43).

10) When Base setting is done, Set Up Wizard will end. If you press the Enter button, the screen changes to the Top screen.

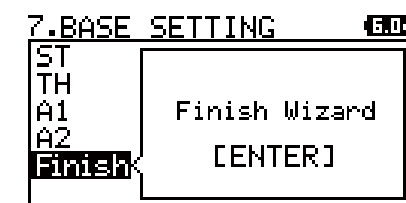
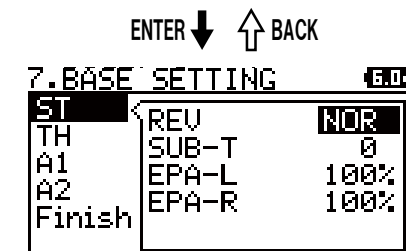
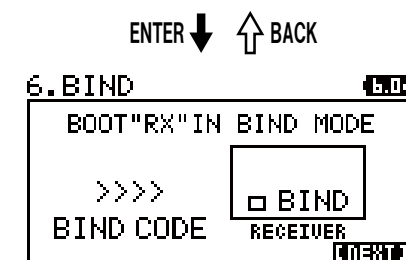
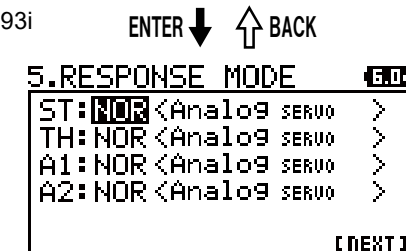
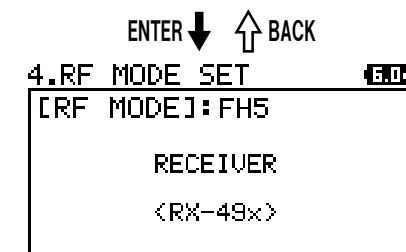

IMPORTANT

- Please note that the analog servos do not work in SHR/SSR/SUR modes. If you mistakenly use the analog servos in SHR/SSR/SUR modes, it does not work normally and the servos will be broken. Never use analog servos in SHR/SSR/SUR modes. For digital servos (SRG, ERB, ERS Series and Digital ERG Series), either NOR or SHR mode works.
- SSR mode works only for PGS, SRG Servos, SUPER VORTEX/SV-PLUS series, HV-12, STOCK SPECIAL and HV-01.
- SUR mode works only for PGS servo, SUPER VORTEX Gen2 / PRO / SV-D2.
- With SHR/SSR/SUR mode, BL-RACER, BL-FORCE, F2000, F2200, F3000, F3300, SBL-01 02 and 03CL do not work. Make sure to use them in NOR mode.
- BL-SIGMA, SV-08, HV-10, HV-12 and F2500 work in NOR/SHR modes.
- Please read user manual of using speed controller.

How to Use Each Feature

ABOUT QUICK SETUP WIZARD

- Quick Setup Wizard function is easily to set up when you set up new RC car.
- Setup Wizard is following start menu→model select→type select→model initialize→RF mode select→response mode select→bind→base setting.

① EP CAR STANDARD

For Standard Electric RC Car Setting

1CH : ST (Steering)	SW1 : TIMER	TR1 : TRM-ST
2CH : ESC (Speed Controller)	SW2 : OFF	TR2 : TRM-TH
3CH : AUX1	SW3 : OFF	TR3 : D/R-ST
4CH : AUX2		

② EP CAR DRIFT

For Drift Car Setting

Pushing TRM3 can change AUX(3CH) setting.

*Connected Gyro in receiver 3CH can be set.

1CH : ST (Steering)	SW1 : TIMER	TR1 : TRM-ST
2CH : ESC (Speed Controller)	SW2 : OFF	TR2 : TRM-TH
3CH : AUX1	SW3 : OFF	TR3 : AUX1
4CH : AUX2		

③ EP CAR (PGS)

For Electric Car setting with PGS servo series for steering.

Connected PGS servo to receiver SSL port can be set by AUX CODE 10 in AUX menu.

1CH : ST (Steering)	SW1 : TIMER	TR1 : TRM-ST
2CH : ESC (Speed Controller)	SW2 : OFF	TR2 : TRM-TH
3CH : AUX1	SW3 : OFF	TR3 : D/R-ST
4CH : CODE (PGS)		

④ EP CAR (SV-G2P)

For Electric Car setting with PGS servo series for steering and SUPER VORTEX Gen2, Gen2 PRO, and SV-D2 for throttle.

Connected PGS servo and the speed controller to receiver SSL port can be set by AUX CODE 10 in AUX menu.

1CH : ST (Steering)	SW1 : TIMER	TR1 : TRM-ST
2CH : ESC (Speed Controller)	SW2 : OFF	TR2 : TRM-TH
3CH : CODE (SV-G/D)	SW3 : OFF	TR3 : D/R-ST
4CH : CODE (PGS)		

⑤ EP CAR (SV-D2)

For Drift Car setting with SUPER VOLTEX Gen2, Gen2 PRO, SV-D2 and SGS-02 for Gyro.

Connected the speed controller and gyro to receiver SSL port can be set by AUX CODE 10 in AUX menu.

⑥ GP CAR STANDARD

For Standard Nitro Car setting

Assigned to turn on and off OFFSET function to SW2.

In case of using PGS servo series for steering and throttle, connected the PGS servo to receiver SSL port can be set by AUX CODE 10 which can set device by transmitter.

1CH : ST (Steering)	SW1 : TIMER	TR1 : TRM-ST
2CH : TH/BR (Throttle/Brake)	SW2 : OFFSET	TR2 : TRM-TH
3CH : AUX1	SW3 : OFF	TR3 : D/R-ST
4CH : CODE (PGS)		

⑦ 1/5GP DUAL -BR1

1CH & 3CH for steering, and 2CH & 4CH for throttle and brake setting

Assigned 2CH brake servo working can be set by TRM2.

Assigned 4CH brake servo working can be set by TRM3.

1CH : ST1 (Steering)	SW1 : TIMER	TR1 : TRM-ST
2CH : TH/BR (Throttle/Brake)	SW2 : OFFSET	TR2 : D/R-BR
3CH : ST2 (Steering)	SW3 : OFF	TR3 : AUX2
4CH : BR (Brake)		

⑧ 1/5GP DUAL-BR2

1CH for steering, 2CH for throttle, and 3CH & 4CH for brake setting

Assigned 3CH brake servo working can be set by TRM2.

Assigned 4CH brake servo working can be set by TRM3.

2CH / 3CH brake servo mixing rate can be set by AUX menu.

2CH / 4CH throttle and brake mixing rate can be also set by AUX menu.

1CH : ST1 (Steering)	SW1 : TIMER	TR1 : TRM-ST
2CH : TH (Throttle)	SW2 : OFFSET	TR2 : AUX1
3CH : BR1 (Brake)	SW3 : OFF	TR3 : AUX2
4CH : BR2 (Brake)		

⑨ CRAWLER 4WS/MOA

1CH & 3CH for steering, and 2CH & 4CH for speed controller setting

4WS mode can be changed by TRM3. [F-ST]⇔[REV]⇔[NOR]⇔[R-ST]

MOA-RATE can be changed by TRM2. [F100:R0]⇔[F100:R100]⇔[F0:R100]

Detailed MOA setting and 4WS setting can be changed by AUX menu.

1CH : ST1 (Steering)	SW1 : TIMER	TR1 : TRM-ST
2CH : ESC1(Speed Controller)	SW2 : OFF	TR2 : AUX2
3CH : ST2 (Steering)	SW3 : OFF	TR3 : AUX1
4CH : ESC2 (Speed Controller)		

Assign Function List

Transmitter LED Indication List

Display Name	Function Name	TRIM	SW1	SW2	SW3
OFF	——(NO FUNCTION)	○	○	○	○
TRIM-ST	Steering Trim	○	—	—	—
TRIM-TH	Throttle Trim	○	—	—	—
TRIM-A1	AUX1 Trim	○	—	—	—
TRIM-A2	AUX2 Trim	○	—	—	—
D/R-ST	Steering Dual Rate	○	○	○	○
D/R-TH	Throttle Dual Rate	○	○	○	○
D/R-BR	Brake Dual Rate	○	○	○	○
CUR-ST	Steering Curve	—	○	○	—
CUR-TH	Throttle Curve	—	○	○	—
CU-R-ST	Steering Curve Rate	○	—	—	○
CU-R-TH	Throttle Curve Rate	○	—	—	○
CU-R-BR	Brake Curve Rate	○	—	—	○
SPD-ST	Steering Speed	—	○	○	—
SPD-TH	Throttle Speed	—	○	○	—
SP-ST-F	Steering Speed Forward	○	—	—	○
SP-ST-R	Steering Speed Return	○	—	—	○
SP-TH-F	Throttle Speed Forward	○	—	—	○
SP-TH-R	Throttle Speed Return	○	—	—	○
ALB	Anti-Lock Brake	—	○	○	—
ALB-PO	Anti-Lock Brake Point	○	—	—	—
ALB-ST	Anti-Lock Brake Stroke	○	—	—	○
ALB-LG	Anti-Lock Brake Lag	○	—	—	○
ALB-CY	Anti-Lock Brake Cycle	○	—	—	○
OFFSET	OFFSET	○	○	○	○
AUX1	AUX1	○	○	○	○
AUX1(CODE1)	AUX1(CODE 1)	○	—	—	○
AUX1(CODE10)	AUX1(CODE10)				
AUX2	AUX2	○	○	○	○
AUX2(CODE1)	AUX2(CODE1)	○	—	—	○
AUX2(CODE10)	AUX2(CODE10)				
ASIST-ST	Steering Drive Assist	—	○	○	—
TIMER	Timer	—	○	—	—
TE-CLR	Telemetry Max Clear	—	○	—	—
LOGGER	Log Clear & Start	—	○	—	—

Settable...「○」 Unsettable...「—」

LED Condition	Working Condition
Light on	Normal Operation (While Transmitter Output)
High-speed Flashing	ALB Working
Medium-speed Flashing	Battery Alarm Working
Flashing	Logger Working
Twice Flashing	OFFSET Working
	Telemetry Working
	POWER ON Alarm Working
High-speed Flashing	Battery (LIMIT) Alarm Working
	Over Voltage Alarm Working
Low-speed Flashing	BIND Command Sending

INDEX

A	
ALERT SETTING	P.42
Anti-Lock Brake [ALB]	P.26
AUX	P.29-34
AUX Mixing [AUX-MIX]	P.33
B	
BASE	P.22-24
BATTERY	P.47
BIND	P.43-44
BUZZER	P.47
C	
CALIBRATION	P.48
CODE AUX	P.34
Curve [CURVE]	P.20
D	
DOWN TIMER	P.40
Dual Rates [D/R]	P.18
E	
End Point Adjustment [EPA]	P.23-24
F	
Fail Safe [F/S]	P.21
4-Wheel Steering [4WS]	P.31
Function [FUNC]	P.25-28
I	
Interval Timer [INT TIMER]	P.40
K	
Key Assignments Switch [KEY ASSIGN SW]	P.45
Key Assignments Trim [KEY ASSIGN TRIM]	P.46
L	
LAP TIMER	P.39
LCD	P.48
M	
MODEL	P.35-38
MODEL CLEAR	P.38
MODEL COPY	P.37
MODEL NAME	P.36
MODEL SELECT	P.35
Motor On Axel [MOA]	P.32
O	
Offset	P.27
P	
POINT AUX	P.30
Q	
QUICK SETUP Wizard	P.49-50
R	
Reverse [REV]	P.22
S	
SETTING	P.18-34
SPEED	P.19
STEP AUX	P.29
SUB TRIM	P.22
SYSTEM	P.43-48
T	
TELEMETRY SETTING	P.42
TIMER	P.39-40
TRIM	P.25

When this happens

Symptom	Cause	Measure
There is no power.	Batteries are consumed. Batteries are placed improperly.	Replace with new batteries or recharged batteries. Reinstall the batteries as the polarity is indicated.
Power is cut off occasionally.	Bad connection of connectors.	Bring to Sanwa Service
Insufficient length	Batteries are consumed.	Replace with new batteries or recharged batteries. If the problem cannot be solved, please contact Sanwa Service
Alarm does not stop.	Battery voltage of the transmitter is drained.	Replace with new batteries or recharged batteries.
There is no click sound when pressing the key.	Volume of the BUZZER feature is OFF (0).	Check BUZZER feature (P.47).
The servo speed is slow.	SPEED feature is set to minus.	Check SPEED feature (P.19).
	Battery voltage of the receiver is decreasing.	Replace with new batteries or recharged batteries.
	Linkage of the car body side is heavy.	Check if the Linkage of the car body side moves lightly.
Steering angles of left and right are different even when they are aligned.	Trim neutral is not aligned.	Align Trim and reset EPA. (P.23, 25)
When operating, the servos will not work on both ends	Steering angle settings of D/R and EPA are too large.	Set either value to below 100%. (P. 18, 23, 24)
Servo did not work even if pushing trim	Trim working range is maximized on one side.	Please reset servo horn and trim center. (P.22)

Service and Support

This is warranted against manufacturer defects in materials and workmanship, at the original date of purchase. This warranty does not cover components worn by use or damage caused by improper voltage, tempering, modification, misuse, abuse, improper wiring, reverse polarity, moisture or using outside its intended scope of use.

Terms of this warranty can vary by region. Please read the warranty card included with your radio control system for specific warranty information.

If you have any questions or concerns, we're here to help. If you encounter a problem with your radio control system, first check the Troubleshooting Guide on Page 56.

If you require further help that cannot be solved using The Troubleshooting Guide, or if you have technical questions, please contact SANWA service center in your region.

For a complete list of distributors in your region, please visit www.sanwa-denshi.com/rc/distributors.html.

For Service In North America:
Serpent America
5121 NW 79 Ave. Unit 03,
Doral, Florida 33166 USA
Telephone: (305)-677-3253
Fax: (305)-675-0415
Email: info@serpentamerica.com

Factory Service:
Sanwa Electronic Instrument CO., LTD.
1-2-50 Yoshita-Honmachi
Higashiosaka, Osaka, 578-0982 Japan
Telephone: 81-729-62-1277
Fax: 81-729-64-2831
Email: rcintl@sanwa-denshi.co.jp

Product features and specifications can vary by region. Not all products are legal for use in all regions.

 Please note that products purchased outside of North America cannot be serviced under warranty by Serpent America. In some cases, we can make repairs for products purchased outside of North America, however, applicable repair costs and shipping charges will be applicable. For warranty claims outside North America, please contact the service center in your region.

FCC COMPLIANCE STATEMENT

This equipment has been tested and found to comply with the limits for a Class B digital device, pursuant to Part 15 of the FCC Rules. These limits are designed to provide reasonable protection against harmful interference in a residential installation. This equipment generates, uses, and can radiate radio frequency energy and, if not installed and used in accordance with the operating instructions, may cause harmful

interference to radio communications. However, there is no guarantee that interference will not occur in a particular installation. If this equipment does cause harmful interference to radio or television reception, which can be determined by turning the equipment OFF and ON, the user is encouraged to try to correct

the interference by one or more of the following measures:

- Reorient or relocate the receiving antenna.
- Increase the separation between the equipment and the receiver.
- Connect the equipment into an outlet on a circuit different from that to which the receiver is connected.
- Consult the dealer or an experienced technician for help.

This device complies with Part 15 of the FCC Rules. Operation is subject to the following two conditions:

- 1) This device may not cause harmful interference, and...
- 2) This device must accept any interference received, including interference that may cause undesired operation.

 Changes or modifications made to this equipment not expressly approved by SANWA may void the FCC authorization to operate this equipment.

RF Exposure Statement:

This transmitter has been tested and meets the FCC RF exposure guidelines when used with the SANWA accessories supplied or designated for this product, and provided at least 20cm separation between the antenna the user's body is maintained. Use of other accessories may not ensure compliance with FCC RF exposure guidelines.



SANWA ELECTRONIC INSTRUMENT CO., LTD.

**1-2-50 Yoshita-Honmachi
Higashiosaka, Osaka, 578-0982 Japan**

**Telephone: 81-729-62-1277
Facsimile: 81-729-64-2831
Email: general@sanwa-denshi.co.jp**

Features and Specifications are Subject to Change Without Notice.
All contents © 2022 Sanwa Electronic Instrument Co., LTD
All Rights Reserved. Revision 1 6.30.2022