

## Step 7-

### Close and lock track.

- Turn knob, at end of each load bar, in direction of orange arrow until the word "LOCK" appears.
- Lock load bar with key.



## Step 8-

### Check your installation. Be certain:

- Daisy dials are tightened completely against wheel tray and upright bracket. Retighten daisy dial against upright bracket after first two hours of initial use.
- Upright clamp is firmly grasping each bike and is in the closed position.
- Wheel straps are used on both front and rear tires.
- Accessory tracks are closed and locked.
- Load is evenly distributed on load bars. For maximum weight limitations, follow recommendations of vehicle manufacturer.
- The entire system including attachment of load bars to the vehicle is stable and secure. Walk around vehicle to check each attachment clip. Refer to attachment clip instructions for correct clip positioning and proper installation.

## Cautions

- 1) All requirements for compatibility/ fit as stated in the current Saris Vehicle/ Carrier Compatibility Guide must be followed.
- 2) Check your installation as recommended. Because vehicles and conditions vary, it is your responsibility to insure the safe and proper use of this product. Improper attachment or misuse may result in damage to your carrier, bicycles, vehicle, or vehicles traveling behind you.
- 3) Use only Saris clips and accessories.
- 4) When in use, remember carrier is installed!
  - a) Be aware of low overhead clearances.
  - b) Do not go through automatic car wash with carrier installed.
  - c) Occasionally check attachment of carrier and load.
- 5) Open vehicle doors before removing carrier; failure to do so could damage doors.
- 6) Replace any part at first sign of fatigue or wear.

## Warning and Disclaimer

This carrier has been designed to carry accessories on specific vehicles. Before installation, user must read and follow current Vehicle/ Carrier Compatibility Guide (available through Saris dealer) recommendations and enclosed instructions. Fit recommendations are based on vehicle's standard features; optional features may affect the fit recommendations. User must attach carrier correctly to the vehicle, check its attachment before each use, and inspect carrier parts for wear. Carrier's attachment to the vehicle is critical and beyond the control of the manufacturer. Manufacturer and seller expressly disclaim any and all liability for personal injury, property damage or loss, whether direct, indirect, or incidental, resulting from the incorrect attachment, improper use, inadequate maintenance, or neglect of this carrier.

## Warranty

We warrant this product to the first consumer to be free from defect in material and workmanship for a period of two years from date of purchase. (Please retain your sales slip for your records.) Any product or part thereof found to be defective within that period will be replaced without charge provided that: (1) the product was not misused; (2) no alterations or modifications were made; (3) its failure resulted from a defect in material or workmanship and not from normal wear expected in the use of the product; (4) the product or part is delivered, freight prepaid, to Graber Products. Manufacturer's only obligation shall be to replace such products or parts proved to be defective.

**SARIS**  
a special products division of **GRABER**

5253 Verona Rd.  
Madison, WI 53711  
800-783-7257  
www.sarisproducts.com

Made in U.S.A.  
911-IS 11/99 Revison B

Worldwide patents  
issued and pending.

# UPRIGHT MOUNT Bicycle Carrier Model #911

Please READ and FOLLOW all instructions carefully!

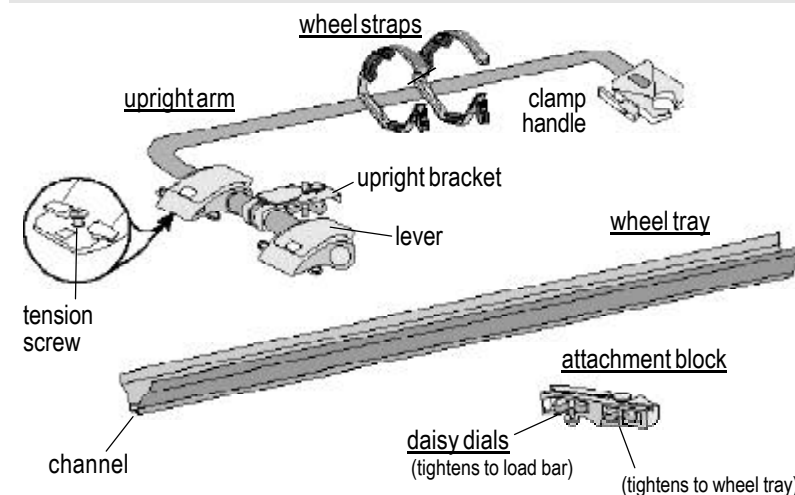

**The Saris Upright Mount Accessory can support bikes with a tire size between 12-1/2 and 27 inches.**

## Step 1-

### Check load bar placement.

Use of the upright mount requires that your load bar spacing be between 16" (minimum) and 36" (maximum).

Refer to **available load bar spacing** in clip set instructions.

If your **available load bar spacing is:**

- less than or equal to 36 inches, place load bars following all recommendations in your clip set instructions.
- greater than 36 inches, place load bars 36" anywhere along the length of your vehicle.



## Step 2-

### Open accessory tracks.

Turn knob 1/2 turn toward gray arrow (loosening rack slightly) until the word "LOCK" is upside down.

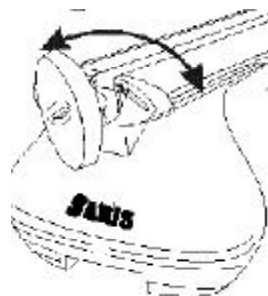

### Note:

For upright clamp locking capabilities, Lock Plug Kits are available through your local Saris dealer. To complete a single key locking system, purchase the Lock Plug item number identical to the number on your Saris load bar key. Insert Lock Plug per instructions before mounting upright arm to load bar.

## Step 3-

### Slide components into tracks.

#### A) Upright Arm

- Lift levers of upright arm.
- Align tabs with load bar accessory track.
- Slide component into track.
- Close levers.

**Note:** Adjustment of lever tension is preset. If component will not slide into track, loosen tension screw between tabs. If component still slides when lever is closed, tighten tension screw.



#### B) Attachment Block

- Position curved side of block down against load bar with wheel tray dial toward opposite load bar.
- Align bolt head with accessory track.
- Slide block into track.

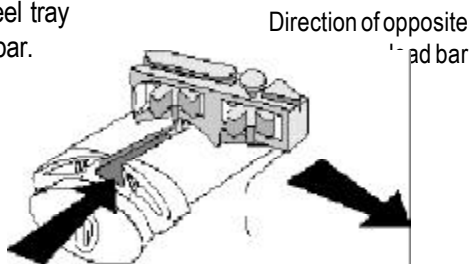

#### C) Wheel Tray

- Loosen daisy dial attached to upright bracket.
- Align attachment block and upright bracket.
- Slide tray channel from back to front (along block to upright bracket).  
**Note:** Slide tray forward enough to overhang load bar approximately 12-14 inches.
- Tighten upright bracket daisy dial against wheel tray. **Note:** Retighten daisy dial after the first two hours of initial use.

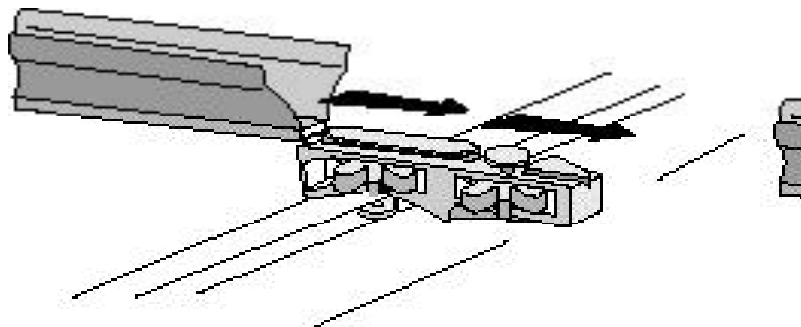

## STEP 4-

### Tighten all parts.

- Adjust and straighten all components.
- Close levers to hold upright arm in place.
- Secure attachment block to load bar and attachment block to wheel tray by turning daisy dials in direction of arrows.

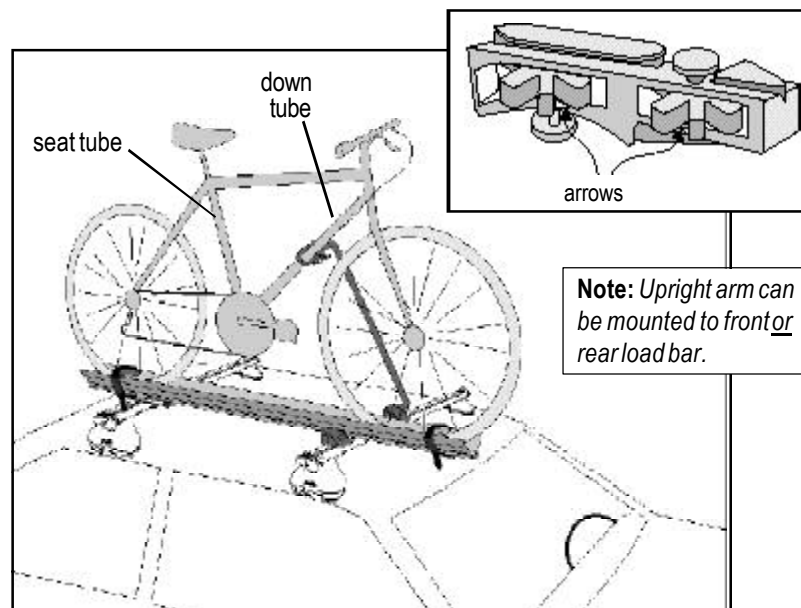

## Step 5-

### Mount additional accessories.

- Distribute bikes evenly along load bars.
- To carry 3 or more bikes, it may be necessary to alternate direction bikes face. To do so, reverse entire setup such that bikes face the opposite direction.
- Balance load evenly.

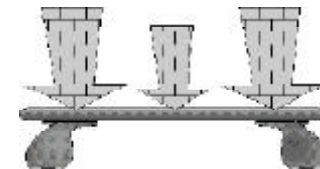

## Step 6-

### Load bikes.

- Lift bike and place tires in wheel tray. (Bikes can face either direction.)
- Open upright clamp, fasten around seat tube with arm next to rear tire or down tube with arm next to front tire (avoiding cables).
- Rotate clamp handle enclosing clamp around bike tube (A) and close handle (B). Clamp should firmly grasp bike tube.
- Align tab of wheel straps with wheel tray channel and slide into place. Secure both tires. Center shim over narrow tires and remove shim for wide tires. Thread strap through buckle and snap buckle down to secure.
- **Note:** When not in use, buckle straps firmly or remove to prevent loss.

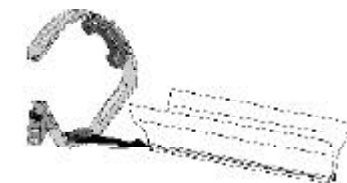
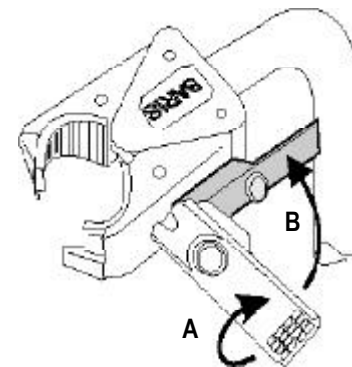

Instructions continued on back...