

**SATELLINE-M3-TR3
AND -TR4
TRANSCEIVER MODULES
INTEGRATION GUIDE**

v.1.6

IMPORTANT NOTICE

All rights to this manual are owned solely by Satel Oy (referred to in this user guide as Satel). All rights reserved. The copying of this manual (without the written permission from the owner) by printing, copying, recording or by any other means, or the full or partial translation of the manual to any other language, including all programming languages, using any electrical, mechanical, magnetic, optical, manual or other methods or devices is forbidden.

Satel reserves the right to change the technical specifications or functions of its products, or to discontinue the manufacture of any of its products or to discontinue the support of any of its products, without any written announcement and urges its customers to ensure, that the information at their disposal is valid.

Satel software and programs are delivered "as is". The manufacturer does not grant any kind of warranty including guarantees on suitability and applicability to a certain application. Under no circumstances is the manufacturer or the developer of a program responsible for any possible damages caused by the use of a program. The names of the programs as well as all copyrights relating to the programs are the sole property of Satel. Any transfer, licensing to a third party, leasing, renting, transportation, copying, editing, translating, modifying into another programming language or reverse engineering for any intent is forbidden without the written consent of SATEL.

SATEL PRODUCTS HAVE NOT BEEN DESIGNED, INTENDED NOR INSPECTED TO BE USED IN ANY LIFE SUPPORT RELATED DEVICE OR SYSTEM RELATED FUNCTION NOR AS A PART OF ANY OTHER CRITICAL SYSTEM AND ARE GRANTED NO FUNCTIONAL WARRANTY IF THEY ARE USED IN ANY OF THE APPLICATIONS MENTIONED.

Salo, FINLAND 2015

Copyright: 2015 Satel Oy

No part of this document may be reproduced, transmitted or stored in a retrieval system in any form or by any means without the prior written permission of Satel Oy. This document is provided in confidence and must not be distributed to third parties without the express permission of Satel Oy.

RESTRICTIONS ON USE

SATELLINE-M3-TR3 and –TR4 radio transceiver modules have been designed to operate on 403-473 MHz, the exact use of which differs from one region and/or country to another. The user of a radio transceiver module must take care that the said device is not operated without the permission of the local authorities on frequencies other than those specifically reserved and intended for use without a specific permit.

SATELLINE-M3-TR3 and –TR4 are allowed to be used in the following countries, either on license free channels or on channels where the operation requires a license. More detailed information is available at the local frequency management authority.

Countries: AT, BE, BG, CA, CH, CY, CZ, DE, DK, EE, ES, FI, FR, GB, GR, HU, IE, IS, IT, LT, LU, LV, MT, NL, NO, PL, PT, RU, RO, SE, SI, SK, US

WARNING! Users of SATELLINE-M3-TR3 and –TR4 radio transceiver modules in North America should be aware, that due to the allocation of the frequency band 406.0 – 406.1 MHz for government use only, the use of radio transceiver module on this frequency band without a proper permit is strictly forbidden.

WARNING - RF Exposure

To comply with FCC and IC RF exposure compliance requirements, maximum antenna gain is 14 dBi and separation distance of at least 1 meter must be maintained between the antenna of this device and all persons. This device must not be co-located or operating in conjunction with any other antenna or transmitter.

Host product labeling requirements

SATELLINE-M3-TR3 and –TR4 is intended to be integrated into a host device. Therefore the SATELLINE-M3-TR3 and –TR4 product related FCC ID and IC ID must be visible in the host device chassis:

FCC ID: MRBSATEL-TA23
IC ID: 2422A-SATELTA23

This integration guide applies to the combination of Firmware version/Hardware version listed in the table below. See www.satel.com for the newest firmware and Integration Guide version.

| Firmware version | Hardware version | Note! |
|------------------|------------------|------------------|
| 07.22.2.0.2.4 | SPL0020d,6 | Since 12.08.2013 |
| 07.22.2.0.3.2 | SPL0020d,7 | 01.10.2013 |

PRODUCT CONFORMITY

Hereby, Satel Oy declares that SATELLINE-M3-TR3 and –TR4 radio transceiver modules are in compliance with the essential requirements (radio performance, electromagnetic compatibility and electrical safety) and other relevant provisions of Directive 1999/5/EC. Therefore the equipment is labeled with the following CE-marking. The notification sign informs user that the operating frequency range of the device is not harmonized throughout the market area, and the local spectrum authority should be contacted before the usage of the radio module.



WARRANTY AND SAFETY INSTRUCTIONS

Read these safety instructions carefully before using the product:

-Warranty will be void, if the product is used in any way that is in contradiction with the instructions given in this manual

-The radio transceiver module is only to be operated at frequencies allocated by local authorities, and without exceeding the given maximum allowed output power ratings. SATEL and its distributors are not responsible, if any products manufactured by it are used in unlawful ways.

-The devices mentioned in this manual are to be used only according to the instructions described in this manual. Faultless and safe operation of the devices can be guaranteed only if the transport, storage, operation and handling of the device are appropriate. This also applies to the maintenance of the products.

TABLE OF CONTENTS

| | |
|--|-----------|
| IMPORTANT NOTICE | 1 |
| RESTRICTIONS ON USE | 2 |
| PRODUCT CONFORMITY..... | 3 |
| WARRANTY AND SAFETY INSTRUCTIONS | 4 |
| TABLE OF CONTENTS | 5 |
| 1 INTRODUCTION | 7 |
| 1.1 Terms and abbreviations | 7 |
| 1.2 Description of the product | 7 |
| 1.3 DTE connector | 8 |
| 1.4 Pin order of the DTE connector..... | 9 |
| 1.5 Antenna interface..... | 10 |
| 2 MECHANICAL CONSIDERATIONS..... | 11 |
| 2.1 Fixing device to host..... | 11 |
| 2.2 Host board instructions for mounting pegs | 11 |
| 3 CHANGING PARAMETERS USING SL COMMANDS | 12 |
| 3.1 SL Commands | 12 |
| 3.2 SL Command Mode..... | 12 |
| 4 OPERATING MODES..... | 14 |
| 4.1 Safe mode..... | 14 |
| 4.2 Power up / power down scenarios | 14 |
| 4.3 Sleep Mode | 15 |
| 4.4 Power Save Mode | 15 |

| | |
|---|-----------|
| 4.5 Restart | 16 |
| 5 TIME PARAMETERS FOR STARTUP AND SHUTDOWN SEQUENCES | 17 |
| 5.1 Startup sequence | 18 |
| 5.2 Shutdown sequence | 18 |
| 5.3 Stat pin | 19 |
| 5.4 Service pin | 19 |
| 6 TECHNICAL SPECIFICATIONS | 20 |
| 6.1 Absolute maximum ratings (* | 22 |
| 6.2 DC electrical specifications | 22 |
| 7 DEFAULT DELIVERY VALUES | 23 |
| 8 CONSIDERATIONS | 24 |
| 8.1 EMI Interferers | 24 |
| 8.2 Electrostatic discharge | 25 |
| 8.3 Using the device in unmanned high reliability applications | 25 |
| 9 APPENDIX | 26 |
| 9.1 SL COMMANDS | 26 |
| 10 VERSION HISTORY | 32 |

1 INTRODUCTION

Satel Oy is a Finnish electronics and Telecommunications Company specializing in the design and manufacture of wireless data communication products. Satel designs, manufactures and sells radio modems intended for use in applications ranging from data transfer to alarm relay systems. End users of Satel products include both public organizations and private individuals.

Satel Oy is the leading European manufacturer of radio modems. Satel radio modems have been certified in most European countries and also in many non-European countries.

This document is the integration guide for the SATELLINE-M3-TR3 and –TR4 radio transceiver modules. It is intended to describe how to use these modules and how to integrate those into a host device.

1.1 Terms and abbreviations

| Abbreviation | Description |
|--------------|---|
| CTS | Clear To Send, handshaking signal used in asynchronous communication. |
| DTE | Data Terminal Equipment (typically computer, terminal...) |
| ESD | Electrostatic discharge |
| RD | Receive Data |
| TD | Transmit Data |
| RTS | Ready To Send, handshaking signal used in asynchronous communication. |
| RAM | Random Access Memory |
| LDO | Low dropout regulator |
| UHF | Ultra High Frequency |
| RF | Radio Frequency |
| FPGA | Field-programmable gate array |
| CPU | Central processing unit |

1.2 Description of the product

The SATELLINE-M3-TR3 and –TR4 are a UHF radio transceiver modules, that transmits and receives data from UHF transmissions made by SATELLINE-3AS family and similar transmitters. The module is designed to be as compact and power efficient as possible. It has been developed to be especially suitable for integration into battery powered and space constrained host applications benefiting from UHF communications.

The module transmits and receives data via the Air interface (Ant. Connector, RF), modulates and demodulates, encodes and decodes the data and sends the received data payload to the DTE port. The DTE interface is used to provide power to the module and communicate with the module.

1.3 DTE connector

The DTE connector is a 20-pin pass-through connector. This connector allows the pin to enter the connector from the bottom side and protrude thru the module PCB to the top side, allowing flexible mounting heights with various pin lengths.

Entry from bottom of device, see picture below.

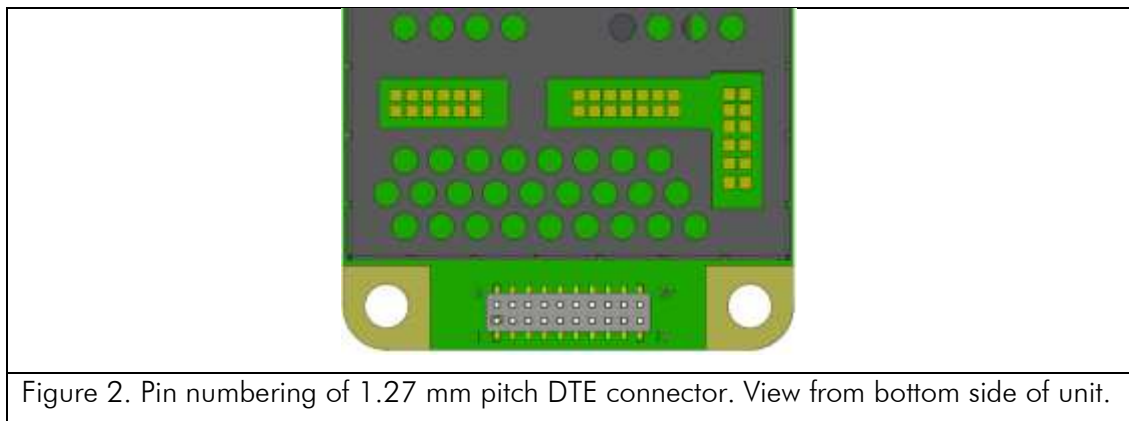
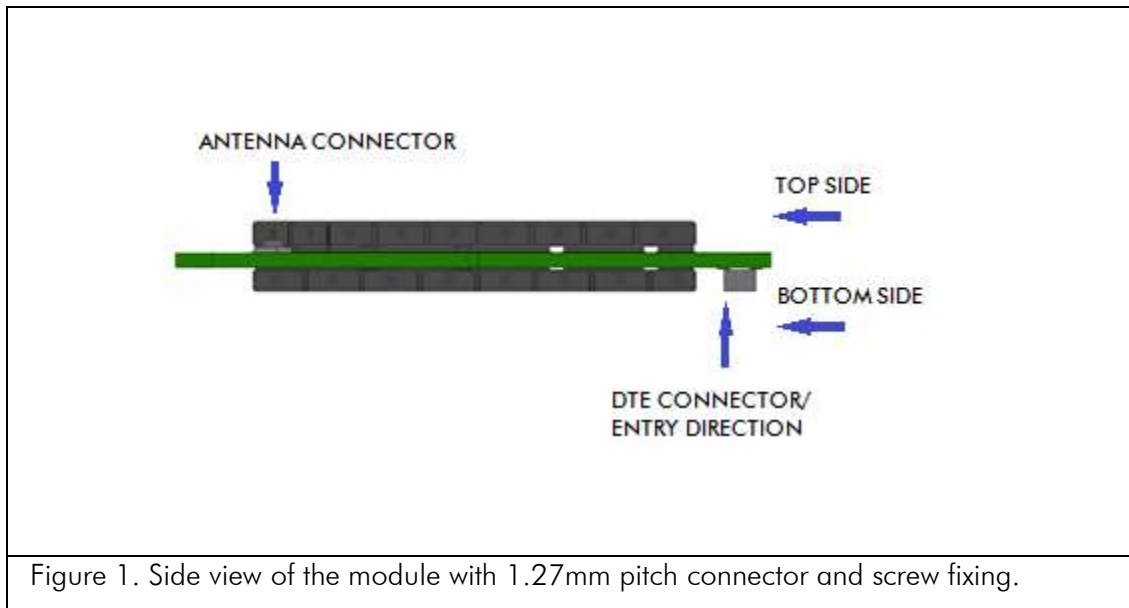

1.4 Pin order of the DTE connector

Direction **IN** is data from DTE (Data Terminal Equipment) to the radio transceiver module.
Direction **OUT** is data from the radio module to the DTE.

| Pin No. | Signal name | Type | Direction | Pin State | Description |
|---------|-------------|-------|-----------|--------------------|--|
| 1,2 | VCC_IN | POWER | IN | External Voltage | 4.0V DC input |
| 3,4 | GND | GND | - | External Ground | Ground reference for power and signals |
| 5 | VCC_IO | POWER | IN | External Voltage | Device IO driver input DC voltage. Voltage= 1.8 ... 3.3 V |
| 6 | ENA_MOD | IO | IN | Internal Pull Down | Enable module by pulling HIGH. >1.2 V= Module power is ON, <0.2 V= Module power is OFF |
| 7 | RD1 | CMOS | OUT | Output Driver | Receive data. Data received by module is output on this pin. Driving this pin is prohibited. |
| 8 | CTS1 | CMOS | OUT | Output Driver | Clear To Send. Module signals when it is ready to receive data. Driving this pin is prohibited. |
| 9 | TD1 | CMOS | IN | Internal Pull Up | Transmit Data. Data from DTE to module shall be sent on this pin. Pull LOW or drive LOW or HIGH. |
| 10 | RTS1 | CMOS | IN | Internal Pull Up | Ready to send. DTE can use this pin to signal when it is ready to receive data from module. Pull LOW or drive LOW or HIGH. |
| 11 | GPIO1 | CMOS | IN | Internal Pull Down | Unconnected. |
| 12 | GPIO2 | CMOS | IN | Internal Pull Down | |
| 13 | GPIO3 | CMOS | IN | Internal Pull Down | |
| 14 | GPIO4 | CMOS | IN | Internal Pull Down | |

| | | | | | |
|----|-----------------------------|------|-----|--------------------|--|
| 15 | STAT | CMOS | OUT | Output Driver | Status signal. "1" when device is OK and working normally. Various toggle sequences for other state indications. See separate section of manual. Can drive LED directly. 10mA output drive capability. Driving this pin is prohibited. |
| 16 | GPIO5 | CMOS | IN | Internal Pull Down | Unconnected |
| 17 | $\overline{\text{SERVICE}}$ | | IN | Internal Pull Up | Input for service access. Internally pulled high. Pull LOW / drive LOW to set UART1 (RD1, TD1) into known state. See separate section of manual. |
| 18 | GPIO6 | CMOS | IN | Internal Pull Down | Unconnected. |
| 19 | GPIO7 | CMOS | IN | Internal Pull Down | Unconnected. |
| 20 | GPIO8 | CMOS | IN | Internal Pull Down | Unconnected. |

1.5 Antenna interface

The antenna interface is a 50 Ω coaxial connector. Matching networks are not included on the module and should be placed in the host application if the antenna is not 50 Ω . The HIROSE U.FL compatible connector is located on the TOP side of the board.

NOTE! The used connector has gold plated contacts - whereas a standard HIROSE U-FL has silver plated contacts.

If silver - gold joints are not allowed in your product, use gold plated cable-connector to mate to this device.

2 MECHANICAL CONSIDERATIONS

2.1 Fixing device to host

The radio transceiver module can be mounted on to the host by using spacers and screws. Max. screw diameter is 3mm.

2.2 Host board instructions for mounting pegs

In figure below is SATELLINE-M3-TR3 with dimensions as millimeters.

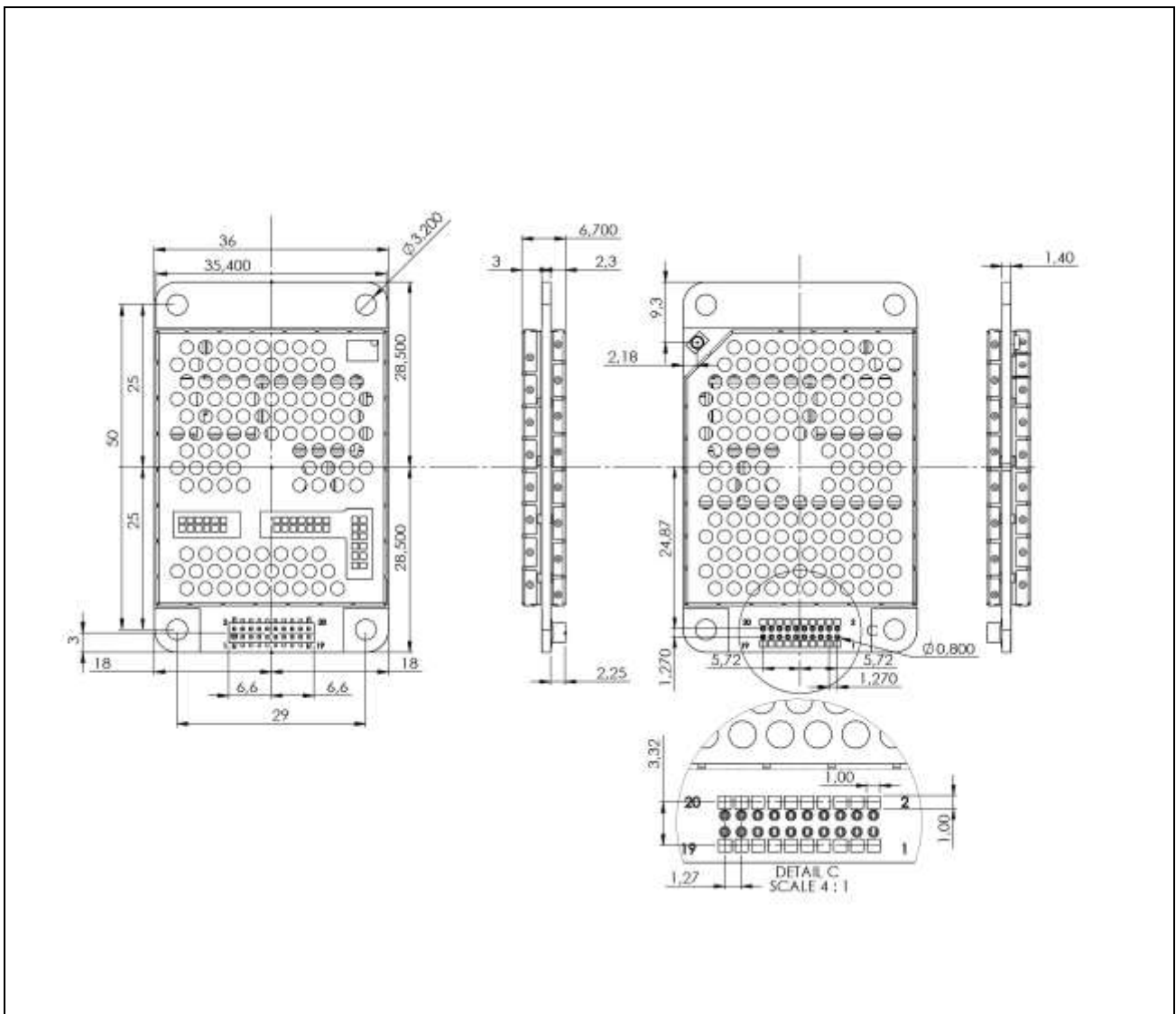

Figure 3. The physical dimensions and the holes in millimeters.

3 CHANGING PARAMETERS USING SL COMMANDS

The controlling terminal device can change the configuration settings of the module. This is accomplished with the help of SL commands. SL commands can be used to change e.g. the frequency or addresses. It is also possible to ask the radio transceiver module to show current settings which are in use.

3.1 SL Commands

An SL command is a continuous string of characters, which is separated from other data by pauses which are equal or greater than time defined by Pause length parameter (default=3 characters) in the set-up. No extra characters are allowed at the end of an SL command.

Serial interface settings are the same as in data transfer. SL command is properly recognised also in the case when the command string is terminated by <CR> (=ASCII character no. 13, Carriage Return, 0x0d) or <CR><LF> (<LF> = ASCII char. no. 10, Line Feed, 0x0a). If multiple SL commands are sent to the module, the next command can be given after receiving the response ("Ok" or "Error") of the proceeding command. In addition, it is recommended to implement a timeout to the terminal software for recovering the case when no response is received from the radio module.

The transceiver module will acknowledge all commands by returning an "OK" (command carried out or accepted) or the requested value, or an "ERROR" (command not carried out or interpreted as erroneous) message.

The SL commands are listed in appendix, pages 26.

3.2 SL Command Mode

The SL commands have always been enabled in the previous products like M3-R3. When the SL commands are enabled there are possibilities that the user data may start with the characters "SL" which is handled as the SL command. This has caused the firmware to go to the continuous SL command search mode and any data has not been sent or even an "ERROR" acknowledgment has been received. To avoid this kind behavior the user can disable the SL commands. The SL commands can be disabled or enabled using the "SL Command mode" parameter. The user can do this via the *SATEL Configuration Manager*, version v1.3.15 or newer.

By default the *SL Command mode* is set to **ON**. If the *SL Command mode* is set to **OFF** then the SL commands can be enabled or disabled using the following procedures:

To enable the SL Commands:

- Send three "+" characters via serial port so that there is at least three bytes delay between each character. The response is "OK", when successfully set.
<+> <at least three bytes pause> <+> <at least three bytes pause> <+>

To disable the SL Commands:

- Send three "-" characters via serial port so that there is at least three bytes delay between each character. The response is "OK", when successfully set.
<-> <at least three bytes pause> <-> <at least three bytes pause> <->

Note!

The "+ + +" and "- - -" procedures are not allowed to be used, when radio is transmitting or receiving data (i.e. the application data occupies the TD or RD lines of the radio).

4 OPERATING MODES

The radio transceiver module has the following modes of operation:

| Mode | Function | Description |
|--------------------------|-----------------|---|
| Ready to receive from RF | Search for sync | Module is searching for the start of a radio transmission from the RF signal. |
| | Receive data | The module has found a valid radio transmission and is receiving data. |
| TX | Transmit | The module transmits |
| Safe mode | | Mode is entered when a fault has been detected and the device has been Rebooted. In safe mode fault codes can be read from the module. |
| Sleep mode | Sleep1 | Will turn the module into a state where it will hold parts of the radio on, wakeup will take approx. 30 ms |
| Power Save mode | Power save | Automatic sleep/wake-up procedure where module sleeping time is dynamically adjusted to received data packets. Decreases the power consumption of complete receiving cycle approx. 30%. |

4.1 Safe mode

When a fault has been detected by the Firmware, the module is set to Safe mode. In this mode the module toggle's the Stat Pin in 250ms interval indicating an Error and reboots the device after 5s. Transmitting/Receiving is prohibited during malfunction. When connecting to the device with SATEL Configuration Manager the Error code is shown in pop up box. If the device does not recover after multiple reboots, please contact Satel Oy.

Satel Configuration Manager can be downloaded from website www.satel.com/downloads.

The version 1.3.15 or newer is compatible with SATELLINE-M3-TR3 and –TR4 radio transceiver modules.

4.2 Power up / power down scenarios

The transceiver module can be set in four (4) states, "ON", "OFF", "sleep1" and "Power Save". When power is applied to the module, the module switches to ON state when voltage in ENA_MOD pin is >1.2V.

The module can be shut down by driving ENA_MOD line to <0.2V.

In the "OFF" state current consumption is only that of leakage current from an LDO (0.34 mA). In this state all non-essential parts of the module are powered down and all settings / state information that are not stored in NVM are reset.

4.3 Sleep Mode

When being in sleep mode, the radio part of the module is switched off while the serial interface communication related parts remain powered on. The module will be automatically woken up after the CPU senses a state change in the TD1 pin. *Example:* The module is in Sleep1- mode. The module is woken up by sending a character or characters into the TD1 pin after which the module responses "OK". After "OK" the module is ready for normal communication.

To turn the module ON from sleep1 mode:

- 1) Issue a state change to TD1 (toggle pin (minimum pulse duration time 10 μ s) or issue a byte on the UART (for example 0x00))
- 2) Wait for "OK" -response from the module. The wake-up time is approx. 30 ms.
- 3) Start communicating normally

Module will remain powered ON until a new sleep command is issued.

4.4 Power Save Mode

The Power save mode performs an automatic, self-adjusting receiver wake-up/sleep cycle. It is designed for applications which base on one-way communication with relatively constant TX interval and, in which the data packet separation is > 200 ms.

When enabled, the unit makes the *transmission interval study* basing on four (4) successfully received data packets. The shortest time between transmitted packets is measured (t_{min}). Measured value is updated after each successfully received data packet, so that possible changes in the message length becomes noted.

Ensuring that the complete messages will be received even if there occur little variation in transmission interval, some safety margin (t_{marg}) is left into Ready to receive from RF mode time.

Safety margin is calculated by dividing the shortest time between transmitted packets (t_{min} , in ms) with 8 and by adding 60 ms to this result:

$$t_{marg} = \frac{t_{min}}{8} + 60 \text{ ms}$$

The length of the whole sleeping period (t_{sleep}) is calculated by decreasing the shortest time between transmitted packets (t_{min}) with safety margin (t_{marg}) and transmission time of the original message (t_{TX}):

$$t_{sleep} = t_{min} - t_{marg} - t_{TX}$$

Transmission interval study is started over always after 100 successful sleep/wake-up cycles and, if the expected receiving slot ($t_{RX\ slot}$) with enhanced overlap margin ($t_{overlap}$) has been missed. In latter case the package is considered to be lost.

$$t_{overlap} = t_{marg} + 100\ ms$$

$$t_{RX\ slot,\ min} = t_{min} - t_{marg}$$

$$t_{RX\ slot,\ max} = t_{min} + t_{overlap}$$

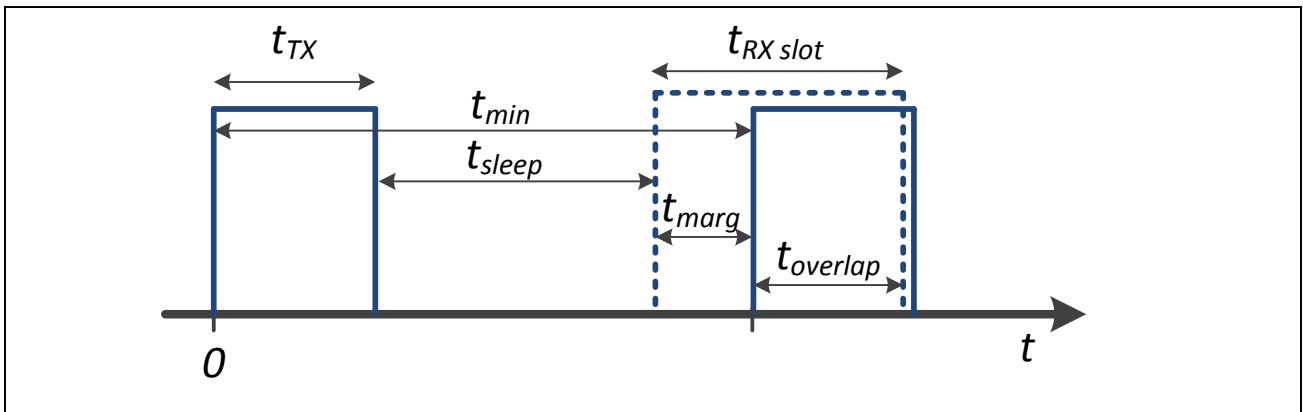

Figure 4. Power save mode timing factors.

E.g. In system with TX interval of 1 s, and with 300 ms (approx. 300B @ 9600 bps) transmission time:

$$t_{min} = 1000\ ms$$

$$t_{TX} = 300\ ms$$

$$t_{marg} = 125\ ms + 60\ ms = 185\ ms$$

$$t_{sleep} = 1000\ ms - (125\ ms + 60\ ms) - 300\ ms = 515\ ms$$

$$t_{RX\ slot,\ min} = 1000\ ms - 185\ ms = 815\ ms$$

$$t_{RX\ slot,\ max} = 1000\ ms + 285\ ms = 1285\ ms$$

4.5 Restart

After startup the module can be restarted by issuing a SL command, upon which the module will shut down all circuitry, and Reboot the CPU (see SL-list).

5 TIME PARAMETERS FOR STARTUP AND SHUTDOWN SEQUENCES

| Parameter | | Recom. Time * | Explanation |
|------------|-----------------------------|---------------|--|
| T_{vic} | Input capacitor charge time | $> 50\mu s$ | When voltage is applied to VCC_IN the filter capacitors inside the module are charged, creating a small current surge. If the feeding power supply is not very strong it is recommended to wait this time before rising ENA_MOD to minimize current surge. |
| T_{ioen} | IO module start time | $< 18ms$ | ENA_MOD enables the LDOs feeding the FPGA and CPU inside the module. It is recommended to apply VCC_IO voltage within 18ms after ENA_MOD is applied. |
| T_{iovs} | IO voltage startup time | $< 1ms$ | It is considered good design practice to KEEP all IO signals (except ENA_MOD) low or floating until the internal parts of the module have power and the IO voltage is stable. |
| T_{ior} | IO drive fall time | $< 300\mu s$ | It is considered good design practice to set all IO signals (except ENA_MOD) low or floating before starting to shut down the transceiver module. This way any latch up/brownout problems can be avoided. IO-pins are not internally driven after Tior. |
| T_{ldof} | LDO discharge time | $> 300\mu s$ | To avoid any possibility of reverse biasing of regulators inside the module, it is considered good design practice to use ENA_MOD to shut down the regulators before deactivating VCC_IN. |

Table. Startup and shutdown sequence parameters.

*) Recommendations:

The radio module is designed and tested for the minimum times mentioned in the table. The recommendations are there for those who want to do the very best possible startup and shutdown sequences.

5.1 Startup sequence

The following diagram will describe the startup sequence.

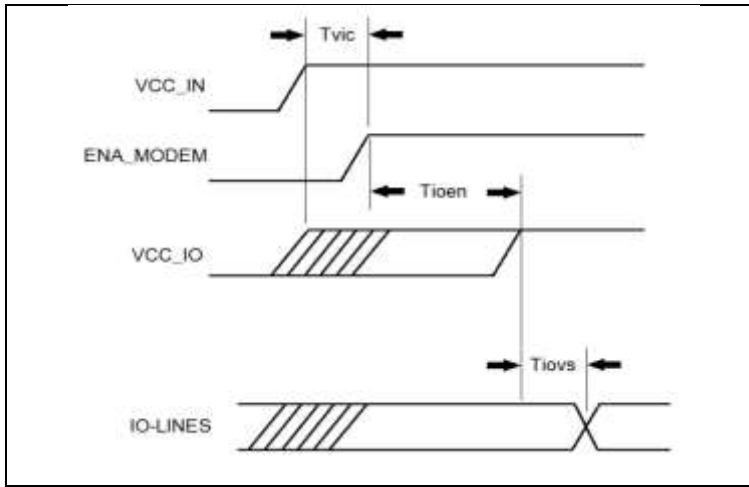

Figure 7. Startup sequence.

5.2 Shutdown sequence

The following diagram will describe the shutdown sequence.

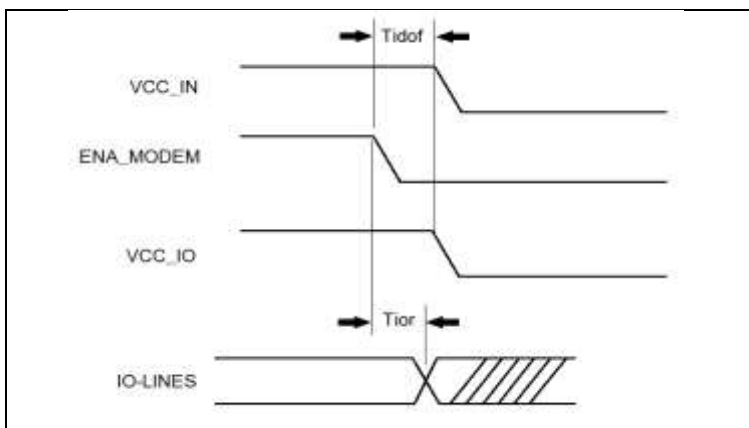

Figure 8. Shutdown sequence.

5.3 Stat pin

The STAT pin indicates the status of the device. It can be used to drive a LED using a series resistor. STAT pin drive capability is 10mA (loads the VCC_IO).
The STAT pin has the following behavior.

| Blink cycle | Mode |
|--|---|
| "1" - statically | module is operational "searching for a new frame" |
| "0" for the endurance of the received frame. | "0" when module is receiving data from air interface. In practical cases will toggle at the frequency of the data packets on the air interface. |
| "0" statically | Module is in sleep1 mode |
| The pin is toggled in transmission interval | Module is sending data Over the Air |
| Pin is toggled in 1s interval | Module has the connection to Configuration Manager program. |
| Pin is toggled in 500ms interval | SL Command mode. |
| Pin is toggled in 250ms interval | Module has detected a fault, fault codes can be read via Configuration Manager program. |

Table. Modes of STAT pin.

5.4 Service pin

The SERVICE pin is used to set the UART1 into a known state. Pulling this pin low will activate the service mode and set the UART1 into 38400, n, 8, 1. This is intended for service access of the module, to have a known serial port setting in order to access the module settings. The pin does not affect any permanent settings, nor does it change the mode of the module. Releasing/ driving the pin high will return serial port 1 into the configured state. When service pin is used the SL Commands are forced to be ON although they are OFF in settings.

6 TECHNICAL SPECIFICATIONS

SATELLINE-M3-TR3 and –TR4 complies with the following international standards:

EN 300 113-2

EN 301 489-1, -5

EN 60950-1

FCC CFR47 PART 90

| | RECEIVER | TRANSMITTER | Note! |
|--|--|-----------------------------|-----------------------------|
| Frequency Range | 403...473 MHz | | |
| Tuning range | 70 MHz | | |
| Minimum RF Frequency Step | 6.25 kHz | | |
| Channel Bandwidth | 12.5 kHz / 25 kHz | | Programmable |
| Frequency Stability | <1 kHz | | |
| Maximum Receiver Input Power without Damage | +14 dBm | | |
| Maximum Receiver Input Power without Transmission Errors | -10 dBm | | FEC ON |
| Sensitivity ^{1,2} | -112 dBm @25 kHz -116 dBm@12.5 kHz | | FEC ON |
| Blocking ^{1,2} | > 86 dB @ 25 kHz > 88 dB @ 12.5 kHz | | FEC ON |
| Intermodulation Attenuation ^{1,2} | > 61 dB @ 25 kHz > 61 @ 12.5 kHz | | FEC ON |
| CO-Channel Rejection ^{1,2} | > -11 dB @25 kHz > -10 dB @12.5 kHz | | FEC ON |
| Adjacent Channel Selectivity ^{1,2} | > 56 dB @ 25 kHz > 51 dB @ 12.5 kHz | | FEC ON |
| Spurious Rejection | > 67 dB | | FEC ON |
| Typical Power Consumption | 730 mW | | RX-mode |
| | SLEEP1: 215 mW | | RX-mode |
| | | 4.7 W @ 1 W RF out | TX-mode, Continuous, 50Ω |
| | | 3.3 W @ 500 mW RF out | TX-mode, Continuous, 50Ω |
| | | 2.8 W @ 100 mW RF out | TX-mode, Continuous, 50Ω |
| | 2.6 W @ 100 mW RF out | TX-mode, Continuous, 50Ω | |
| Transmitter Power (programmable) | | 0.01, 0.1, 0.2, 0.5, 1 W | TX-mode, 50Ω load |
| Communication Mode | Half-Duplex | | |
| Adjacent Channel Power | | acc. to EN 300 113-1v.1.7.1 | TX-mode |
| Transient Adjacent Channel Power | | acc. to EN 300 113-1v.1.7.1 | TX-mode |
| Carrier power stability | | < ±1.5 dB | |

| | DATA MODULE | |
|-----------------------------------|--|---|
| Timing | UART | |
| Electrical Interface | CMOS Inputs and outputs referred to IO Voltage processed by user (1.8-3.3V) RTS, CTS, RX, TX, +VCC, GND | |
| Interface Connector | 1.27 mm pitch socket | Samtec 20-pin through hole, CLP-110-02-L-D-K-TR |
| Data speed of Serial interface | 1200 – 115200 bps | |
| Data speed of Radio Air Interface | <u>4FSK FEC ON (TR3 and TR4):</u> 19200 bps (25 kHz) 9600 bps (12.5 kHz) <u>8FSK FEC OFF (TR4):</u> 28800 bps (25 kHz) 14400 bps (12.5 kHz) <u>8FSK FEC ON (TR4):</u> 19200 bps (25 kHz) 9600 bps (12.5 kHz) <u>16FSK FEC ON (TR4):</u> 28800 bps (25 kHz) 14400 bps (12.5 kHz) | |
| Air Interface Encryption | AES128 | Programmable |
| Data Format | Asynchronous data | |
| Modulation | 4FSK, GMSK (SATELLINE-M3-TR3) 4-, 8-, 16FSK, GMSK (SATELLINE-M3-TR4) | |

| | GENERAL | |
|--|---------------------------|--|
| Operating voltage | +4.0 VDC | min. ⁵ 4.0V, max. Nominal +5% |
| Maximum DC Ripple Voltage ³ | max. 9 mVpp | DC ≤ f ≤ 1 kHz |
| | max. 64 mVpp | 1 kHz < f ≤ 10 kHz |
| | mx. 517 mVpp | 10 kHz < f ≤ 100 kHz |
| | max. 2.035 Vpp | f > 100 kHz |
| Inrush Current, power turned ON ⁴ | < 12A, duration < 50 μs | RX-mode |
| Inrush Current, from RX to TX ⁴ | not detected | TX output power 1W |
| | < 150 mA, duration < 1 ms | TX output power 500 mW |
| | < 70 mA, duration < 1 ms | TX output power 200 mW |
| | < 30 mA, duration < 1 ms | TX output power 100 mW |
| Temperature Range | -20°C ... +55°C | Type Approval conditions |
| Temperature Ranges | -30°C ... +70°C | Functional |
| | -40°C ... + 80°C | Storage |
| Vibration ⁶ | ≤ 10g | 100Hz ≤ f _{vibration} ≤ 1,0 kHz |
| ESD | ± 10 kV | Antenna connector. Acc. to EN61000-4-2; 150pF/330Ω |
| | ± 8 kV | DTE connector. Acc. to EN61000-4-2; 150pF/330Ω |

| | | |
|-------------------|----------------------------------|-----------------------|
| Antenna Connector | 50Ω, HIROSE U.FL compatible | I-PEX 20279-001 -E-01 |
| Construction | PWB with sheet metal EMI shields | |
| Size L x W x T | 57 x 36 x 6.7 mm | |
| Weight | 18g | |

Test condition $V_{CC} = 4.0\text{ V}$ and $T_A = 25\text{ °C}$

¹ According to EN 300 113-1 V.1.7.1 measurement setup

² The measured average of a sample of 19 M3-TR3 modules

³ Higher values exceed the -36 dBm spurious limit at the antenna e.g. EN 300 113-1 requirement.

⁴ Measured using Agilent 1147B current probe and TTI TSX1820P DC power supply

⁵ If 1 W output power is wanted then 4.0 V is the minimum DC voltage

⁶ Functional operation is guaranteed in all directions xyz

6.1 Absolute maximum ratings (*)

Absolute maximum ratings for voltages on different pins are listed in the following table. Exceeding these values will cause permanent damage to the module.

| Parameter | Min | Max |
|---|--------|---------|
| Voltage at VCC_IN | -0.3 V | +5 V |
| Voltage at ENA_MOD | -0.3 V | +6 V |
| Voltage at VCC_IO | -0.5 V | 3.75 V |
| Voltage at digital inputs (except ENA_MOD) | -0.5 V | 3.75 V |
| Voltage at digital outputs (when no power is applied to unit) | -0.5 V | 3.75 V |
| Antenna port power | n.a. | +14 dBm |
| Antenna port DC voltage | -10V | +10V |

Table. Absolute maximum ratings of module. (* All voltages are referenced to GND)

6.2 DC electrical specifications

Over recommended operating conditions

| Parameter | Condition | Min | Max | Units |
|-------------------------------------|-----------------------------------|-------------------|-----------------|-------|
| VCC_IN | 4.0V is considered nominal | 4.0V ¹ | Nominal +5% | V |
| ENA_modem, Vlow | | 0.9 | VCC_IN | V |
| ENA_modem, Vhigh | | 0 | 0.4 | V |
| Logic input, Vlow | 1.8V < VCC_IO < 3.3V | -0.3 | < 0.35 * VCC_IO | V |
| Logic input, Vhigh | 1.8V < VCC_IO < 3.3V | 0.65 * VCC_IO | 3.6 | V |
| Logic output, Vlow | 1.8V < VCC_IO < 3.3V | - | 0.4 | V |
| Logic output, Vhigh | 1.8V < VCC_IO < 3.3V | VCC_IO - 0.4 | 3.6 | V |
| Logic output, max current | All logic output except STAT pin. | - | 4 | mA |
| Logic output, max current, STAT pin | | - | 12 | mA |

¹ Minimum voltage if the maximum TX output power (1W/50 Ω load) is wanted. Meets the ETSI requirements on given operating voltage range.

7 DEFAULT DELIVERY VALUES

| DEFAULT VALUES OF THE ADJUSTABLE SETTINGS (the user can change these settings later on) | | |
|---|-----------------|---|
| Setting | Default value | Range |
| Radio frequency | | |
| Operating TX and RX frequency | 438.000 MHz | 403 - 473 MHz |
| Channel Spacing | 12.5 kHz | 12.5 kHz or 25 kHz |
| Transmitter Output Power | 1 W | 100 mW, 200 mW, 500 mW and 1 W |
| Radio settings | | |
| Radio Compatibility | SATEL 3AS | SATEL 3AS PacCrest-4FSK PacCrest-GMSK PacCrest-FST TrimTalk450s(P) TrimTalk450s(T) |
| Addressing | | |
| RX Address | OFF | ON/OFF |
| TX Address | OFF | ON/OFF |
| Serial port | | |
| Data speed | 115200 bps | 1200 -115200 bps |
| Data bits | 8 | 8 |
| Parity bits | None | None, Even, Odd |
| Stop bits | 1 | 1 |
| Handshaking | | |
| CTS | TX Buffer State | Handshaking lines apply to the DATA-port Clear to send, TX Buffer State |
| RTS | Ignored | Ignored, Flow Control |
| Additional setup | | |
| Error Correction, FEC | OFF | ON/OFF |
| Error check | OFF | OFF, CRC8Partial, CRC8Full, CRC16Full |
| SL Command Mode | ON | ON/OFF |
| Repeater Mode | OFF | ON/OFF |
| TX Delay | 0 | 0 ... 65535 ms |
| Over-the-Air-Encryption | OFF | ON/OFF |
| Use Channel List | OFF | ON/OFF |
| Power Save Mode | OFF | ON/OFF |
| Add RSSI to Data | OFF | ON/OFF |

8 CONSIDERATIONS

8.1 EMI Interferers

The module is designed to be mounted inside a host device. The module is designed to withstand EMI even beyond type approval requirements. However, a small module which is integrated closely to modern high speed electronics is bound to receive some interference.

To make a working integration, consider the following: EMI can enter the module in four ways:

- 1) Via the antenna (radiation from enclosure enters the antenna)
- 2) Radiated disturbances to the coaxial cable
- 3) Radiation from other electronics / cabling directly to the module
- 4) Conducting through the DTE interface (power, control and data lines).

Because the module is shielded and the DTE interface is filtered, the usually worst method of disturbance is via the antenna port, which is easily overlooked in design. Keep in mind that the radio module has a sensitivity of approx. -115 dBm (depends on mode of operation and speed etc.). While the module has an approx. 10 dB S/N requirement, this constitutes, that any signal entering the radio antenna on receive frequency on a level of $< -125 \text{ dBm}$ ($-115\text{dBm}-10\text{dB}$), causes desensitization of the radio on that particular channel.

Example:

An interferer has a level of -100dBm on the frequency 421 MHz. The radio will show an approximate sensitivity of -90dB ($-100\text{dBm} + \text{S/N requirement } 10 \text{ dB}$) on 421 MHz.

Now consider that generic EMC requirements usually have pass/fail criteria of -57dBm (if normalized to the surface of the device). **So there is almost a 70dB gap between generic EMC requirements and co-existence requirements between a high sensitivity narrowband radios.**

To avoid problems of co-existence a good design should apply:

- 1) EMI shielding in enclosure – ambient air interface
- 2) careful layout
- 3) shielding of all digital high speed parts and cables
- 4) Have a clocking plan to avoid clock frequencies causing harmonics on the UHF band of interest.

Number one is to recognize this challenge and act upon it.

Satel R&D can help in this by participating in design review of the host device, aiming to catch problems early in the design phase.

8.2 Electrostatic discharge

As the module is intended to be embedded in a host application, in a typical use case, the antenna port is the only port of the module directly interface with a surface or contact area subjected to Electrostatic Discharge (ESD).

Thus, the antenna port is the only interface with high level ESD protection. The DTE port also features ESD protection diodes, but is not designed to withstand similar performance as expected from standalone units with enclosures.

Consequently, the module should be subject to ESD handling precautions that typically apply to ESD sensitive components. Proper ESD handling and packaging procedures must be applied throughout the processing, handling and operation of any application that incorporates this module.

The module fulfills the ESD values listed in the following table.

| Specification / Requirement | Contact discharge | Air discharge |
|--|-------------------|---------------|
| EN 61000-4-2 | | |
| Antenna interface | ±10kV | <±15kV |
| DTE interface | ±8kV | - |
| JEDEC JESD22-A114D (Human Body Model, Test conditions: 1.5 kΩ, 100 pF) | | |
| Module surface | ±1kV | n.a. |

Table. ESD ratings. Measured Acc. to EN 61000-4-2 specification.

8.3 Using the device in unmanned high reliability applications

The module features software and hardware watchdogs which are incorporated inside the CPU. While we believe that this is a reliable method of keeping the module in operational condition, there are parts of the module that can't be monitored for proper operation to 100%. For example the module chip has a firmware that resides in the chips RAM. The firmware can't be read back or reloaded, without interrupting reception. Hence the module can't reload this automatically by itself without causing breaks in communication.

To avoid the module from ending up in a state where for example the module chip firmware is corrupted for example by ionizing radiation, it is recommended that the controlling system implements some form of watchdog function for the module.

This can be done for example if the system knows that data should be received every second, and no data has been received for a minute – then do a module restart using the ENA_MOD pin or by issuing a restart command, or a cold boot by toggling VCC_IN low and high again.

9 APPENDIX

9.1 SL COMMANDS

| Category | Command | Description | Response |
|-------------|----------------------------|--|---|
| Addressing | SL#A? | Show all addresses (RX1, RX2, TX1, TX2) | "xxxx,yyyy,zzzz,vvvv" |
| Addressing | SL#A=xxxx, yyyy, zzzz,vvvv | Set RX/TX addresses (RX1, RX2, TX1, TX2) | "OK" or "ERROR" |
| Addressing | SL#I? | Get primary addresses (TX1, RX1) | "xxxx;yyyy" |
| Addressing | SL#I=xxxx | Set all addresses (RX1, RX2, TX1, TX2) to value xxxx [0000....ffff] | "OK" or "ERROR" |
| Addressing | SL#P? | Get primary transmit address (TX1) and primary receive address (RX1) | "xxxx;yyyy" |
| Addressing | SL#P=xxxx;yyyy | Set primary transmit address (TX1) to value xxx and primary receive address (RX1) to value yyyy [0000....ffff] | "OK" or "ERROR" |
| Addressing | SL#Q? | Get TX address mode | "0" = TX address OFF "1" = TX address ON |
| Addressing | SL#Q=x | Set TX address ON/OFF. Values of x are: "0" = TX address OFF "1" = TX address ON | "OK" or "ERROR" |
| Addressing | SL#R? | Get primary receive address (RX1) | "yyyy" |
| Addressing | SL#R=xxxx | Set receive addresses (RX1, RX2) to value xxxx [0000....ffff] | "OK" or "ERROR" |
| Addressing | SL#S? | Get secondary transmit address (TX2) and secondary receive address (RX2) | "xxxx;yyyy" |
| Addressing | SL#S=xxxx;yyyy | Set secondary transmit address (TX2) to value xxx and secondary receive address (RX2) to value yyyy [0000....ffff] | "OK" or "ERROR" |
| Addressing | SL#T? | Get primary transmit address (TX1) | "xxxx" |
| Addressing | SL#T=xxxx | Set transmit addresses (TX1, TX2) to value xxxx [0000....ffff] | "OK" or "ERROR" |
| Addressing | SL#W? | Get RX address mode | "0" = RX address OFF "1" = RX address ON |
| Addressing | SL#W=x | Set RX address ON/OFF. Values of x are: "0" = RX address OFF "1" = RX address ON | "OK" or "ERROR" |
| ChannelList | SL\$A=1 | Go to channel list default channel | "OK" or "ERROR" |

| | | | |
|-------------|---|--|--|
| ChannelList | SL\$C? | Get number of channels in channel list | decimal number |
| ChannelList | SL\$C=nn | Set number of channels in channel list. nn = 0...40, 0 clears the whole list | "OK" or "ERROR" |
| ChannelList | SL\$D? | Get channel list default channel number | decimal number |
| ChannelList | SL\$D=n | Set channel list default channel, n is channel number | "OK" or "ERROR" |
| ChannelList | SL\$E=1 | Search free channel Modem searches for next traffic-free channel. Listening time of traffic is about 2 seconds Modem shows next free channel by activating command again | "OK" followed by "channel n is free" Value of n is channel number of next free channel on channel list |
| ChannelList | SL\$F? | Get active channel number | decimal number |
| ChannelList | SL\$F=n | Set modem to channel number n in channel list | "OK" or "ERROR" |
| ChannelList | SL\$L?nn | Get channel info. Index nn=[0...(number of channels-1)] | Channel number, Frequency, Channel width, Tx Power For example: "CH 1, 430.150000 MHz, 25.0 kHz, 100 mW\OD" |
| ChannelList | SL\$L=laa,Nbbb bbb,Fccc.cccccc, Wdd.ddd,Peeee <CR> | I = Index field aa = 0...39 //Future reservation 0...255 N = Channel number field bbbbbb = -32767...32767 F = Tx/Rx Frequency field ccc.cccccc = Tx/Rx Frequency in MHz (only numbers or "." allowed, "," is not allowed) W = Channel spacing/width field dddd = 12.5, 20 or 25 (unit is kHz, trailing decimals are tolerated e.g. "25", "25.0", "25.00" and "25.000" are all valid) P = Transmitter power field eeeee = 0...35000 (modem rounds the value to the closest applicable) Note: 0 means "don't care" value for power. <CR> = Carriage return character | "OK" or "ERROR" |
| ChannelList | SL\$M? | Get status of channel list. 0 = Not in use, 1 = Channel list in use | "0" or "1" |
| ChannelList | SL\$M=n | Set status of channel list. 0 = Not in use, 1 = Channel list in use | "OK" |
| ChannelList | SL\$R? | Get listening time (seconds) of Search free channel function | decimal number |

| | | | |
|-------------|--------------|---|--|
| ChannelList | SL\$R=n | Set listening time (seconds) of Search free channel function | "OK" or "ERROR" |
| ChannelList | SL\$S=1 | Set channel scanning mode When activated, modem scans channels one by one and saves RSSI readings to memory | "OK" followed by channel/RSSI info For example: "OKCH 6 - 122 dBm, CH 22 -121 dBm, CH 10003 -122 dBm, " |
| DataPort | SL%B? | Get serial data parameters | baud rate, character length, parity, number of stop bits (for example "38400, 8, N, 1") |
| DataPort | SL%B=a,b,c,d | Set serial data port parameters. a= "115200", "57600", "38400", "19200", "9600", "4800", "2400" or "1200" (defines baud rate) b="8" (defines character length) c= "N", "O" or "E" (defines parity) d= "1" (defines number_of_stop bits) | "OK" or "ERROR" |
| Memory | SL**> | Save current settings as permanent settings | "OK" or "ERROR" |
| Memory | SL*R> | Restore settings to their factory set values | "OK" or "ERROR" |
| ModemInfo | SLIH? | Get radio HW info | "HW:nnnnn" |
| ModemInfo | SLIV? | Get modem "type" | Depending on variant, for example "M3-TR3" |
| ModemInfo | SL%1? | Get arbitrary data stored in memory location 1 | If empty data is stored, response = "Undefined", otherwise data and carriage return |
| ModemInfo | SL%1="data" | Set arbitrary data (max 25 characters) in memory location 1 | "OK" or "ERROR" |
| ModemInfo | SL%2? | Get arbitrary data stored in memory location 2 | If empty data is stored, response = "Undefined", otherwise data and carriage return |
| ModemInfo | SL%2="data" | Set arbitrary data (max 25 characters) in memory location 2 | "OK" or "ERROR" |
| ModemInfo | SL%3? | Get arbitrary data stored in memory location 3 | If empty data is stored, response = "Undefined", otherwise data and carriage return |
| ModemInfo | SL%3="data" | Set arbitrary data (max 25 characters) in memory location 3 | "OK" or "ERROR" |
| ModemInfo | SL%4? | Get arbitrary data stored in memory location 4 | If empty data is stored, response = "Undefined", otherwise data and carriage return |

| | | | |
|---------------|---------------------|---|--|
| ModemInfo | SL%4="data" | Set arbitrary data (max 25 characters) in memory location 4 | "OK" or "ERROR" |
| ModemInfo | SL%D? | Get Modem Type | Depends on model, for example "M3-TR3" |
| ModemInfo | SL%H? | Get logic hardware version | Hardware info |
| ModemInfo | SL%S? | Get Serial Number | Serial number of radio modem |
| ModemInfo | SL%V? | Get firmware revision information | For example "V07.22.2.3.0.2" |
| OperationMode | SL+S=x | Activate sleep mode "1" turn the modem into a state where it will hold serial interface parts of the module on, wakeup will take approx. 30ms "5" Turns ON Power save mode. "6" Turns OFF Power save mode. | "OK" or "ERROR" |
| RadioFreq | SL!D? | Get lower limit of frequency band 1 | "nnn.nnnnn MHz" |
| RadioFreq | SL!U? | Get upper limit of frequency band 1 | "nnn.nnnnn MHz" |
| RadioFreq | SL!W? | Get lower limit of frequency band 2 | "nnn.nnnnn MHz" |
| RadioFreq | SL!Y? | Get upper limit of frequency band 2 | "nnn.nnnnn MHz" |
| RadioFreq | SL&F? | Get active frequency | "nnn.nnnnn MHz" |
| RadioFreq | SL&F=nnn.nnnn n | Set active frequency to nnn.nnnnn MHz | "OK" or "ERROR" |
| RadioFreq | SL&FR? | Get Rx frequency | "nnn.nnnnn MHz" |
| RadioFreq | SL&FR=nnn.nnn nn | Set Rx frequency to nnn.nnnnn MHz | "OK" or "ERROR" |
| RadioFreq | SL&FT? | Get Tx frequency | "nnn.nnnnn MHz" |
| RadioFreq | SL&FT=nnn.nnn nn | Set Tx frequency to nnn.nnnnn MHz | "OK" or "ERROR" |
| RadioFreq | SL&W? | Get channel spacing/channel width | "25.0 kHz", "12.5 kHz" |
| RadioFreq | SL&W=xxxx | Set channel spacing. Value of xxxx is: "1250" for 12,5 kHz "2500" for 25 kHz Before using this command, make sure that active frequency matches new channel spacing | "OK" or "ERROR" |
| RadioProperty | SL%F? | Get status of Error correction (FEC) | "0" = FEC OFF , "1" = FEC ON |
| RadioProperty | SL%F=x | Set Error correction (FEC). Value of x is: "1" Set FEC ON "0" Set FEC OFF | "OK" or "ERROR" |

| | | | |
|---------------|------------|---|---|
| RadioProperty | SL%E? | Get status of Error check and Full CRC16 check modes | "0" Error check off "1" CRC8 Partial "2" CRC8 Full "3" CRC16 Full |
| RadioProperty | SL%E=x | Set Error check and Full CRC16 check modes. Value of x is: "0" Error check off "1" CRC8 Partial "2" CRC8 Full "3" CRC16 Full | "OK" or "ERROR" |
| RadioProperty | SL%R? | Get region code setting/status | 0,0 = Default, 1,1 = US, 1,2 = US & Illegal radio setting combination (TX is disabled) |
| RadioProperty | SL@D? | Get Tx delay (ms) | For example "0 ms" or "50 ms" |
| RadioProperty | SL@D=n | Set Tx delay (ms), n is [0...65535] | "OK" or "ERROR" |
| RadioProperty | SL@E? | Get supported radio compatibility modes. | List of numbers, separated by commas, showing the supported modes: 0=Satel3AS, 1=PacCrest 4FSK, 2=PacCrest GMSK, 3=TrimTalk, 4=TrimTalk Trimble, 5=PCC FST For example: "0,1" indicates that the modem supports Satel3AS and PacCrest 4FSK protocols. |
| RadioProperty | SL@F? | Get noise level of radio channel | "-xxx dBm" |
| RadioProperty | SL@M? | Get repeater function | "O" = Repeater OFF(character O) "R" = Repeater ON |
| RadioProperty | SL@M=x | Set repeater function. Values of x are: "O" = Repeater function OFF(character O) "R" = Repeater function ON | "OK" or "ERROR" |
| RadioProperty | SL@P? | Get transmitter output power | One of these values "100mW", "200mW", "500mW", "1000 mW" |
| RadioProperty | SL@P=nnnnn | Set RF output power (mW) For example "SL@P=100" sets 100 mW transmitter output power. "100" sets 100 mW transmitter output power. "200" sets 200 mW transmitter output power. "500" sets 500 mW transmitter output power. "1000" sets 1000 mW transmitter output power. | "OK" / "ERROR" |

| | | | |
|----------------|-----------|--|---|
| RadioProperty | SL@R? | Get RSSI (Received Signal Strength Indication) of last received message (dBm) | "-nnn dBm", nnn is a decimal value of field strength between -80 dBm and -118 dBm. Value is available 7 s after reception, after that the response is "<-118 dBm". SATELLINE-3AS Epic returns the stronger value of two transceivers. |
| Radio Property | SL@S? | Get radio compatibility mode | "0" = SATELLINE-3AS "1" = PacCrest-4FSK (Option1) "2" = PacCrest-GMSK (Option2) "3" = Trimtalk450s(P) (Option 3, RX fits PacCrest modems) "4" = Trimtalk450s(T) (Option 4, RX fits Trimble modems) "5" = PacCrest-FST (Option 5) |
| RadioProperty | SL@S=x | Set radio compatibility mode. Value of x is: 0 = SATELLINE-3AS 1 = PacCrest-4FSK (Option1) 2 = PacCrest-GMSK (Option2) 3 = Trimtalk450s(P) (Option 3, RX fits PacCrest modems) 4 = Trimtalk450s(T) (Option 4, RX fits Trimble modems) 5 = PacCrest-FST (Option5) 20 = 8FSK FEC OFF (TR4 only) 21 = 8FSK FEC ON (TR4 only) 22 = 16FSK FEC ON (TR4 only) | "OK" or "ERROR" |
| Reset | SL@X=n | Reset command. Values of n are: "9" Reset modem | "OK" or "ERROR", then modem resets required blocks. |
| Test | SL+P=xxxx | Get measured signal strength from remote modem i.e. SL "ping" Value of xxxx [0000...ffff] defines address of remote modem | "OK" followed by RSSI info from remote modem |

10 VERSION HISTORY

Version history:

| Version: | Date: | Remarks: |
|----------|------------|--|
| 0.1 | 15.05.2013 | First Draft. |
| 0.2 | 27.5.2013 | Modified by ML |
| 0.2 | 30.5.2013 | Reviewed by R&D |
| 0.3 | 3.6.2013 | Modified by ML |
| 0.3 | 11.6.2013 | Reviewed by JPu |
| 0.4 | 12.6.2013 | new draft version 0.4 by ML |
| 0.4 | 17.06.2013 | Reviewed by R&D |
| 0.4 | 17.06.2013 | Modified by ML |
| 0.4 | 18.06.2013 | Reviewed by R&D |
| 0.5 | 18.06.2013 | Modified by KSu |
| 0.6 | 19.06.2013 | Modified by ML |
| 0.7 | 23.08.2013 | Updated information in the table in paragraph 1.4 and specification tables, updated SL command response for SL!H? command. |
| 1.0 | 03.10.2013 | Added Power save mode description, updated Timing parameters table (in chapter 5). General modifications. |
| 1.1 | 01.11.2013 | Added RF Exposure warning and host device labeling requirements. |
| 1.2 | 09.01.2014 | Modified RF Exposure warning |
| 1.3 | 14.05.2014 | Measurement image updated |
| 1.5 | 07.05.2015 | Output power corrected, DoC added |
| 1.6 | 22.05.2015 | Added TR4 information |