

SATELLINE-M3-TR3
TRANSCEIVER MODULE
INTEGRATION GUIDE

v.1.2

IMPORTANT NOTICE

All rights to this manual are owned solely by SATEL OY (referred to in this user guide as SATEL). All rights reserved. The copying of this manual (without the written permission from the owner) by printing, copying, recording or by any other means, or the full or partial translation of the manual to any other language, including all programming languages, using any electrical, mechanical, magnetic, optical, manual or other methods or devices is forbidden.

SATEL reserves the right to change the technical specifications or functions of its products, or to discontinue the manufacture of any of its products or to discontinue the support of any of its products, without any written announcement and urges its customers to ensure, that the information at their disposal is valid.

SATEL software and programs are delivered "as is". The manufacturer does not grant any kind of warranty including guarantees on suitability and applicability to a certain application. Under no circumstances is the manufacturer or the developer of a program responsible for any possible damages caused by the use of a program. The names of the programs as well as all copyrights relating to the programs are the sole property of SATEL. Any transfer, licensing to a third party, leasing, renting, transportation, copying, editing, translating, modifying into another programming language or reverse engineering for any intent is forbidden without the written consent of SATEL.

SATEL PRODUCTS HAVE NOT BEEN DESIGNED, INTENDED NOR INSPECTED TO BE USED IN ANY LIFE SUPPORT RELATED DEVICE OR SYSTEM RELATED FUNCTION NOR AS A PART OF ANY OTHER CRITICAL SYSTEM AND ARE GRANTED NO FUNCTIONAL WARRANTY IF THEY ARE USED IN ANY OF THE APPLICATIONS MENTIONED.

Salo, FINLAND 2014

Copyright: 2014 SATEL Oy

No part of this document may be reproduced, transmitted or stored in a retrieval system in any form or by any means without the prior written permission of SATEL Oy. This document is provided in confidence and must not be distributed to third parties without the express permission of SATEL Oy.

RESTRICTIONS ON USE

SATELLINE-M3-TR3 radio transceiver module has been designed to operate on 403-473 MHz, the exact use of which differs from one region and/or country to another. The user of a radio transceiver module must take care that the said device is not operated without the permission of the local authorities on frequencies other than those specifically reserved and intended for use without a specific permit.

SATELLINE-M3-TR3 is allowed to be used in the following countries, either on license free channels or on channels where the operation requires a license. More detailed information is available at the local frequency management authority.

Countries: AT, BE, BG, CA, CH, CY, CZ, DE, DK, EE, ES, FI, FR, GB, GR, HU, IE, IS, IT, LT, LU, LV, MT, NL, NO, PL, PT, RU, RO, SE, SI, SK, US

WARNING! Users of SATELLINE-M3-TR3 radio transceiver modules in North America should be aware, that due to the allocation of the frequency band 406.0 – 406.1 MHz for government use only, the use of radio transceiver module on this frequency band without a proper permit is strictly forbidden.

WARNING - RF Exposure

To comply with FCC and IC RF exposure compliance requirements, maximum antenna gain is 14 dBi and separation distance of at least 1 meter must be maintained between the antenna of this device and all persons. This device must not be co-located or operating in conjunction with any other antenna or transmitter.

Host product labeling requirements

SATELLINE-M3-TR3 is intended to be integrated into a host device. Therefore the SATELLINE-M3-TR3 product related FCC ID and IC ID must be visible in the host device chassis:

FCC ID: MRBSATEL-TA23
IC ID: 2422A-SATELTA23

This integration guide applies to the combination of Firmware version/Hardware version listed in the table below. See www.satel.com for the newest firmware and Integration Guide version.

Firmware version	Hardware version	Note!
07.22.2.0.2.4	SPL0020d,6	Since 12.08.2013
07.22.2.0.3.2	SPL0020d,7	01.10.2013

PRODUCT CONFORMITY

Hereby, SATEL Oy declares that SATELLINE-M3-TR3 radio transceiver module is in compliance with the essential requirements (radio performance, electromagnetic compatibility and electrical safety) and other relevant provisions of Directive 1999/5/EC. Therefore the equipment is labeled with the following CE-marking. The notification sign informs user that the operating frequency range of the device is not harmonized throughout the market area, and the local spectrum authority should be contacted before the usage of the radio module.



WARRANTY AND SAFETY INSTRUCTIONS

Read these safety instructions carefully before using the product:

-Warranty will be void, if the product is used in any way that is in contradiction with the instructions given in this manual

-The radio transceiver module is only to be operated at frequencies allocated by local authorities, and without exceeding the given maximum allowed output power ratings. SATEL and its distributors are not responsible, if any products manufactured by it are used in unlawful ways.

-The devices mentioned in this manual are to be used only according to the instructions described in this manual. Faultless and safe operation of the devices can be guaranteed only if the transport, storage, operation and handling of the device are appropriate. This also applies to the maintenance of the products.

TABLE OF CONTENTS

IMPORTANT NOTICE	1
RESTRICTIONS ON USE	2
PRODUCT CONFORMITY	3
WARRANTY AND SAFETY INSTRUCTIONS	4
TABLE OF CONTENTS	5
1 INTRODUCTION	7
1.1 Terms and abbreviations	7
1.2 Description of the product	7
1.3 DTE connector	8
1.4 Pin order of the DTE connector	9
1.5 Antenna interface	10
2 MECHANICAL CONSIDERATIONS	11
2.1 Fixing device to host	11
2.2 Host board instructions for mounting pegs	11
3 CHANGING PARAMETERS USING SL COMMANDS	12
3.1 SL Commands	12
3.2 SL Command Mode	12
4 OPERATING MODES	14
4.1 Safe mode	14
4.2 Power up / power down scenarios	14
4.3 Sleep Mode	15

4.4	Power Save Mode	15
4.5	Restart	16
5	TIME PARAMETERS FOR STARTUP AND SHUTDOWN SEQUENCES	17
5.1	Startup sequence	18
5.2	Shutdown sequence	18
5.3	Stat pin	19
5.4	Service pin	19
6	TECHNICAL SPECIFICATIONS	20
6.1	Absolute maximum ratings (*	22
6.2	DC electrical specifications	22
7	DEFAULT DELIVERY VALUES	23
8	CONSIDERATIONS	24
8.1	EMI Interferers	24
8.2	Electrostatic discharge	25
8.3	Using the device in unmanned high reliability applications	25
9	APPENDIX	26
9.1	SL COMMANDS	26
10	VERSION HISTORY	32

1 INTRODUCTION

SATEL OY is a Finnish electronics and Telecommunications Company specializing in the design and manufacture of wireless data communication products. SATEL designs, manufactures and sells radio modems intended for use in applications ranging from data transfer to alarm relay systems. End users of SATEL products include both public organizations and private individuals.

SATEL OY is the leading European manufacturer of radio modems. SATEL radio modems have been certified in most European countries and also in many non-European countries.

This document is the integration guide for the SATELLINE-M3-TR3 radio transceiver module. It is intended to describe how to use the module and how to integrate it into a host device.

1.1 Terms and abbreviations

Abbreviation	Description
CTS	Clear To Send, handshaking signal used in asynchronous communication.
DTE	Data Terminal Equipment (typically computer, terminal...)
ESD	Electrostatic discharge
RD	Receive Data
TD	Transmit Data
RTS	Ready To Send, handshaking signal used in asynchronous communication.
RAM	Random Access Memory
LDO	Low dropout regulator
UHF	Ultra High Frequency
RF	Radio Frequency
FPGA	Field-programmable gate array
CPU	Central processing unit

1.2 Description of the product

The SATELLINE-M3-TR3 is a UHF radio transceiver module, which transmits and receives data from UHF transmissions made by SATELLINE-3AS family and similar transmitters. The module is designed to be as compact and power efficient as possible. It has been developed to be especially suitable for integration into battery powered and space constrained host applications benefiting from UHF communications.

The module transmits and receives data via the Air interface (Ant. Connector, RF), modulates and demodulates, encodes and decodes the data and sends the received data payload to the DTE port. The DTE interface is used to provide power to the module and communicate with the module.

1.3 DTE connector

The DTE connector is a 20-pin pass-through connector. This connector allows the pin to enter the connector from the bottom side and protrude thru the module PCB to the top side, allowing flexible mounting heights with various pin lengths.

Entry from bottom of device, see picture below.

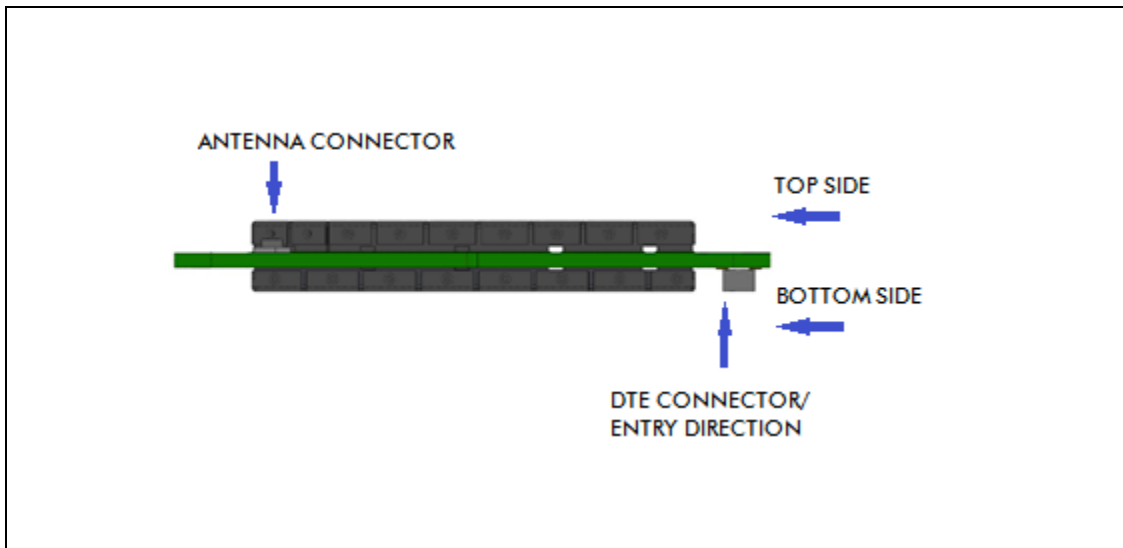

Figure 1. Side view of the module with 1.27mm pitch connector and screw fixing.

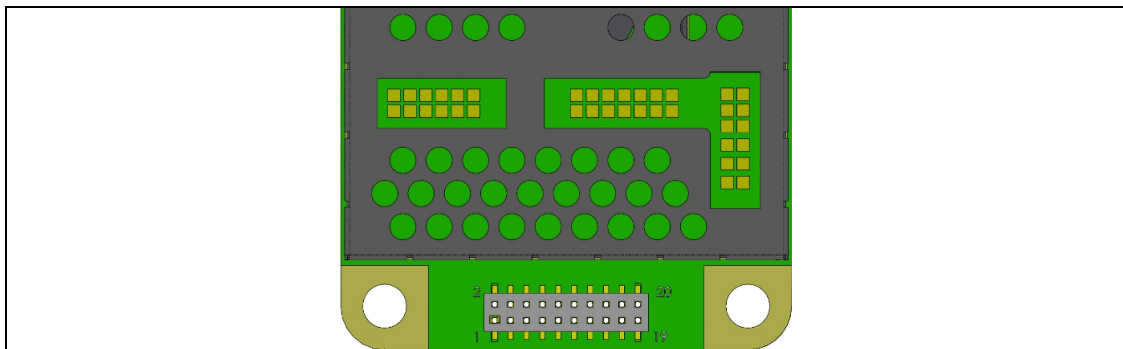

Figure 2. Pin numbering of 1.27 mm pitch DTE connector. View from bottom side of unit.

1.4 Pin order of the DTE connector

Direction **IN** is data from DTE (Data Terminal Equipment) to the radio transceiver module.
Direction **OUT** is data from the radio module to the DTE.

Pin No.	Signal name	Type	Direction	Pin State	Description
1,2	VCC_IN	POWER	IN	External Voltage	4.0V DC input
3,4	GND	GND	-	External Ground	Ground reference for power and signals
5	VCC_IO	POWER	IN	External Voltage	Device IO driver input DC voltage. Voltage= 1.8 ... 3.3 V
6	ENA_MOD	IO	IN	Internal Pull Down	Enable module by pulling HIGH. > 1.2 V= Module power is ON, <0.2 V= Module power is OFF
7	RD1	CMOS	OUT	Output Driver	Receive data. Data received by module is output on this pin. Driving this pin is prohibited.
8	CTS1	CMOS	OUT	Output Driver	Clear To Send. Module signals when it is ready to receive data. Driving this pin is prohibited.
9	TD1	CMOS	IN	Internal Pull Up	Transmit Data. Data from DTE to module shall be sent on this pin. Pull LOW or drive LOW or HIGH.
10	RTS1	CMOS	IN	Internal Pull Up	Ready to send. DTE can use this pin to signal when it is ready to receive data from module. Pull LOW or drive LOW or HIGH.
11	GPIO1	CMOS	IN	Internal Pull Down	Unconnected.
12	GPIO2	CMOS	IN	Internal Pull Down	
13	GPIO3	CMOS	IN	Internal Pull Down	
14	GPIO4	CMOS	IN	Internal Pull Down	

15	STAT	CMOS	OUT	Output Driver	Status signal. "1" when device is OK and working normally. Various toggle sequences for other state indications. See separate section of manual. Can drive LED directly. 10mA output drive capability. Driving this pin is prohibited.
16	GPIO5	CMOS	IN	Internal Pull Down	Unconnected
17	$\overline{\text{SERVICE}}$		IN	Internal Pull Up	Input for service access. Internally pulled high. Pull LOW / drive LOW to set UART1 (RD1, TD1) into known state. See separate section of manual.
18	GPIO6	CMOS	IN	Internal Pull Down	Unconnected.
19	GPIO7	CMOS	IN	Internal Pull Down	Unconnected.
20	GPIO8	CMOS	IN	Internal Pull Down	Unconnected.

1.5 Antenna interface

The antenna interface is a 50 Ω coaxial connector. Matching networks are not included on the module and should be placed in the host application if the antenna is not 50 Ω . The HIROSE U.FL compatible connector is located on the TOP side of the board.

NOTE! The used connector has gold plated contacts - whereas a standard HIROSE U-FL has silver plated contacts.

If silver - gold joints are not allowed in your product, use gold plated cable-connector to mate to this device.

2 MECHANICAL CONSIDERATIONS

2.1 Fixing device to host

The radio transceiver module can be mounted on to the host by using spacers and screws. Max. screw diameter is 3mm.

2.2 Host board instructions for mounting pegs

In figure below is SATELLINE-M3-TR3 with dimensions as millimeters.

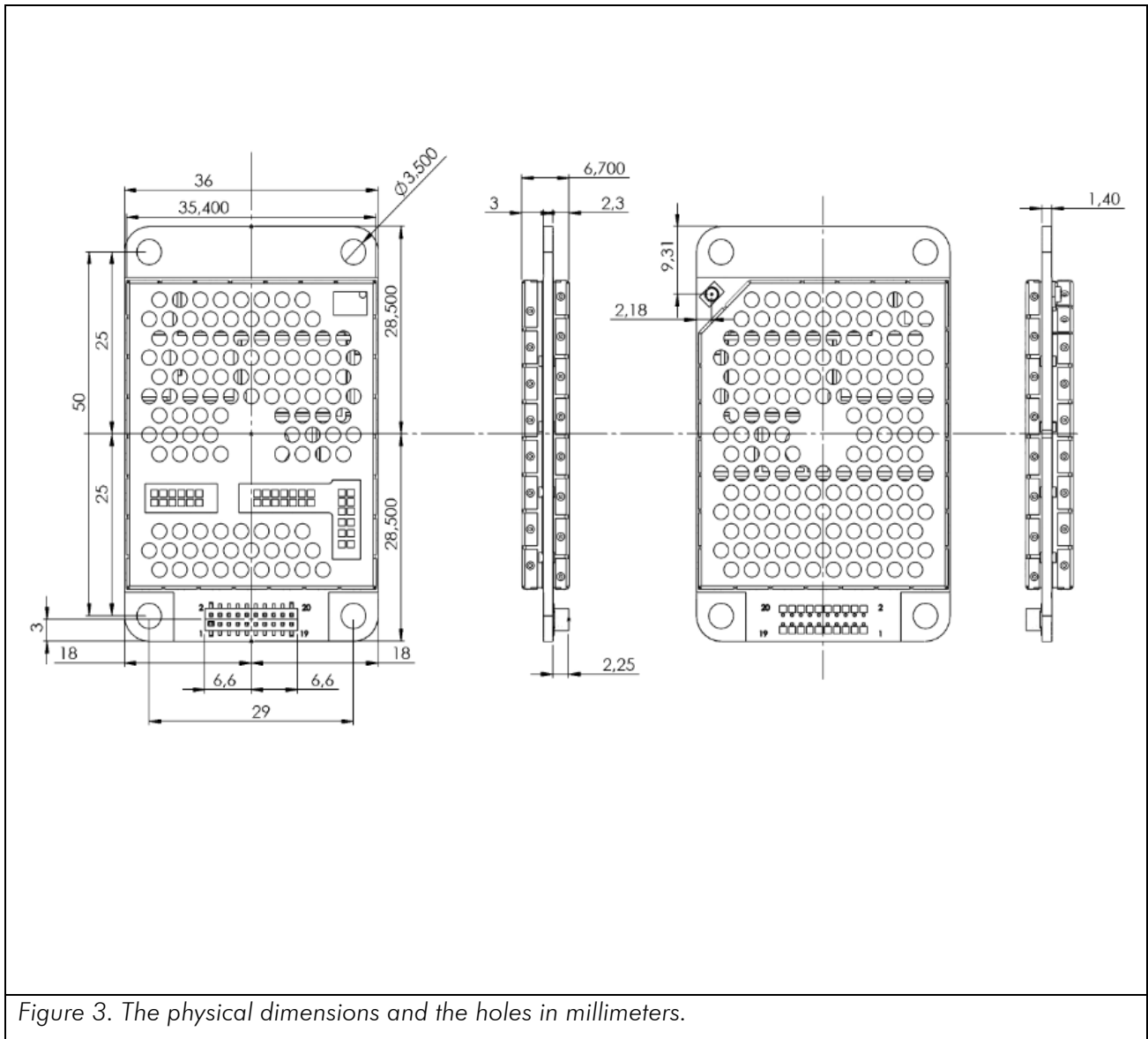

Figure 3. The physical dimensions and the holes in millimeters.

3 CHANGING PARAMETERS USING SL COMMANDS

The controlling terminal device can change the configuration settings of the module. This is accomplished with the help of SL commands. SL commands can be used to change e.g. the frequency or addresses. It is also possible to ask the radio transceiver module to show current settings which are in use.

3.1 SL Commands

An SL command is a continuous string of characters, which is separated from other data by pauses which are equal or greater than time defined by Pause length parameter (default=3 characters) in the set-up. No extra characters are allowed at the end of an SL command.

Serial interface settings are the same as in data transfer. SL command is properly recognised also in the case when the command string is terminated by <CR> (=ASCII character no. 13, Carriage Return, 0x0d) or <CR><LF> (<LF> = ASCII char. no. 10, Line Feed, 0x0a). If multiple SL commands are sent to the module, the next command can be given after receiving the response ("Ok" or "Error") of the proceeding command. In addition, it is recommended to implement a timeout to the terminal software for recovering the case when no response is received from the radio module.

The transceiver module will acknowledge all commands by returning an "OK" (command carried out or accepted) or the requested value, or an "ERROR" (command not carried out or interpreted as erroneous) message.

The SL commands are listed in appendix, pages 26.

3.2 SL Command Mode

The SL commands have always been enabled in the previous products like M3-R3. When the SL commands are enabled there are possibilities that the user data may start with the characters "SL" which is handled as the SL command. This has caused the firmware to go to the continuous SL command search mode and any data has not been sent or even an "ERROR" acknowledgment has been received. To avoid this kind behavior the user can disable the SL commands. The SL commands can be disabled or enabled using the "SL Command mode" parameter. The user can do this via the SATEL Configuration Manager, version v1.3.15 or newer.

By default the SL Command mode is set to **ON**. If the SL Command mode is set to **OFF** then the SL commands can be enabled or disabled using the following procedures:

To enable the SL Commands:

- Send three "+" characters via serial port so that there is at least three bytes delay between each character. The response is "OK", when successfully set.
<+><at least three bytes pause><+><at least three bytes pause><+>

To disable the SL Commands:

- Send three "-" characters via serial port so that there is at least three bytes delay between each character. The response is "OK", when successfully set.
<-><at least three bytes pause><-><at least three bytes pause><->

Note!

The "+ + +" and "- - -" procedures are not allowed to be used, when radio is transmitting or receiving data (i.e. the application data occupies the TD or RD lines of the radio).

4 OPERATING MODES

The radio transceiver module has the following modes of operation:

Mode	Function	Description
Ready to receive from RF	Search for sync	Module is searching for the start of a radio transmission from the RF signal.
	Receive data	The module has found a valid radio transmission and is receiving data.
TX	Transmit	The module transmits
Safe mode		Mode is entered when a fault has been detected and the device has been Rebooted. In safe mode fault codes can be read from the module.
Sleep mode	Sleep1	Will turn the module into a state where it will hold parts of the radio on, wakeup will take approx. 30 ms
Power Save mode	Power save	Automatic sleep/wake-up procedure where module sleeping time is dynamically adjusted to received data packets. Decreases the power consumption of complete receiving cycle approx. 30%.

4.1 Safe mode

When a fault has been detected by the Firmware, the module is set to Safe mode. In this mode the module toggle's the Stat Pin in 250ms interval indicating an Error and reboots the device after 5s. Transmitting/Receiving is prohibited during malfunction. When connecting to the device with SATEL Configuration Manager the Error code is shown in pop up box. If the device does not recover after multiple reboots, please contact SATEL Oy.

SATEL Configuration Manager can be downloaded from website www.satel.com/downloads.

The version 1.3.15 or newer is compatible with SATELLINE-M3-TR3 radio transceiver module.

4.2 Power up / power down scenarios

The transceiver module can be set in four (4) states, "ON", "OFF", "sleep1" and "Power Save". When power is applied to the module, the module switches to ON state when voltage in ENA_MOD pin is >1.2V.

The module can be shut down by driving ENA_MOD line to <0.2V.

In the "OFF" state current consumption is only that of leakage current from an LDO (0.34 mA). In this state all non-essential parts of the module are powered down and all settings / state information that are not stored in NVM are reset.

4.3 Sleep Mode

When being in sleep mode, the radio part of the module is switched off while the serial interface communication related parts remain powered on. The module will be automatically woken up after the CPU senses a state change in the TD1 pin. Example: The module is in Sleep1- mode. The module is woken up by sending a character or characters into the TD1 pin after which the module responses "OK". After "OK" the module is ready for normal communication.

To turn the module ON from sleep1 mode:

- 1) Issue a state change to TD1 (toggle pin (minimum pulse duration time 10 μ s) or issue a byte on the UART (for example 0x00))
- 2) Wait for "OK" -response from the module. The wake-up time is approx. 30 ms.
- 3) Start communicating normally

Module will remain powered ON until a new sleep command is issued.

4.4 Power Save Mode

The Power save mode performs an automatic, self-adjusting receiver wake-up/sleep cycle. It is designed for applications which base on one-way communication with relatively constant TX interval and, in which the data packet separation is > 200 ms.

When enabled, the unit makes the transmission interval study basing on four (4) successfully received data packets. The shortest time between transmitted packets is measured (t_{min}). Measured value is updated after each successfully received data packet, so that possible changes in the message length becomes noted.

Ensuring that the complete messages will be received even if there occur little variation in transmission interval, some safety margin (t_{marg}) is left into Ready to receive from RF mode time.

Safety margin is calculated by dividing the shortest time between transmitted packets (t_{min} , in ms) with 8 and by adding 60 ms to this result:

$$t_{min}8 + 60 \text{ ms}$$

The length of the whole sleeping period (t_{sleep}) is calculated by decreasing the shortest time between transmitted packets (t_{min}) with safety margin (t_{marg}) and transmission time of the original message (t_{TX}):

$$t_{sleep} = t_{min} - t_{marg} - t_{TX}$$

Transmission interval study is started over always after 100 successful sleep/wake-up cycles and, if the expected receiving slot ($t_{RX\ slot}$) with enhanced overlap margin ($t_{overlap}$) has been missed. In latter case the package is considered to be lost.

$$t_{overlap} = t_{marg} + 100\ ms$$

$$t_{RX\ slot,\ min} = t_{min} - t_{marg}$$

$$t_{RX\ slot,\ max} = t_{min} + t_{overlap}$$

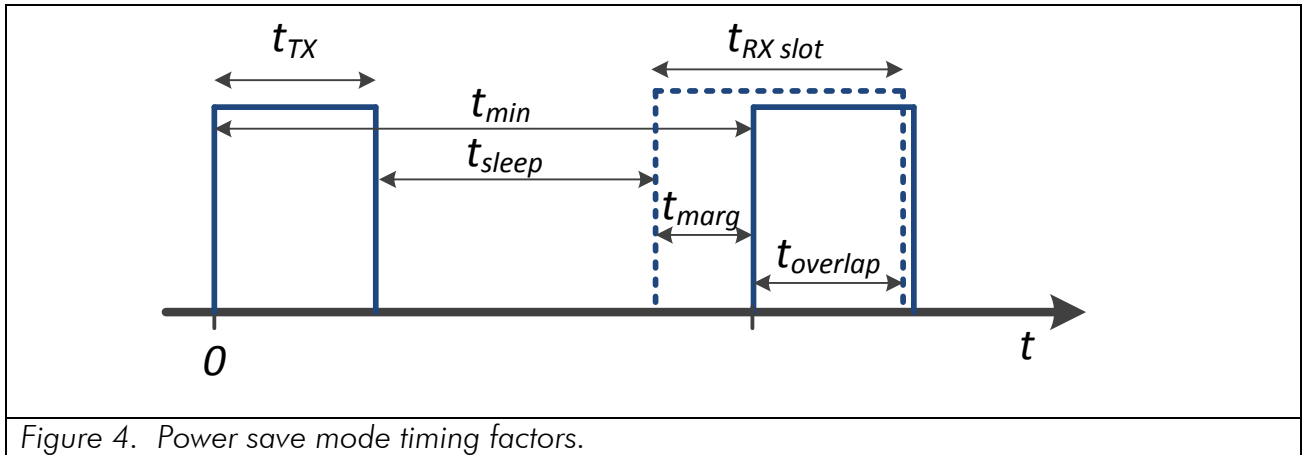

Figure 4. Power save mode timing factors.

E.g. In system with TX interval of 1 s, and with 300 ms (approx. 300B @ 9600 bps) transmission time:

$$t_{min} = 1000\ ms$$

$$t_{TX} = 300\ ms$$

$$t_{marg} = 125\ ms + 60\ ms = 185\ ms$$

$$t_{sleep} = 1000\ ms - (125\ ms + 60\ ms) - 300\ ms = 515\ ms$$

$$t_{RX\ slot,\ min} = 1000\ ms - 185\ ms = 815\ ms$$

$$t_{RX\ slot,\ max} = 1000\ ms + 285\ ms = 1285\ ms$$

4.5 Restart

After startup the module can be restarted by issuing a SL command, upon which the module will shut down all circuitry, and Reboot the CPU (see SL-list).

5 TIME PARAMETERS FOR STARTUP AND SHUTDOWN SEQUENCES

Parameter		Recom. Time	Explanation
T_{vic}	Input capacitor charge time	$> 50\mu s$	When voltage is applied to VCC_IN the filter capacitors inside the module are charged, creating a small current surge. If the feeding power supply is not very strong it is recommended to wait this time before rising ENA_MOD to minimize current surge.
T_{ioen}	IO module start time	$< 18ms$	ENA_MOD enables the LDOs feeding the FPGA and CPU inside the module. It is recommended to apply VCC_IO voltage within 18ms after ENA_MOD is applied.
T_{iovs}	IO voltage startup time	$< 1ms$	It is considered good design practice to KEEP all IO signals (except ENA_MOD) low or floating until the internal parts of the module have power and the IO voltage is stable.
T_{ior}	IO drive fall time	$< 300\mu s$	It is considered good design practice to set all IO signals (except ENA_MOD) low or floating before starting to shut down the transceiver module. This way any latch up/brownout problems can be avoided. IO-pins are not internally driven after Tior.
T_{ldof}	LDO discharge time	$> 300\mu s$	To avoid any possibility of reverse biasing of regulators inside the module, it is considered good design practice to use ENA_MOD to shut down the regulators before deactivating VCC_IN.

Table. Startup and shutdown sequence parameters.

*) Recommendations:

The radio module is designed and tested for the minimum times mentioned in the table. The recommendations are there for those who want to do the very best possible startup and shutdown sequences.

5.1 Startup sequence

The following diagram will describe the startup sequence.

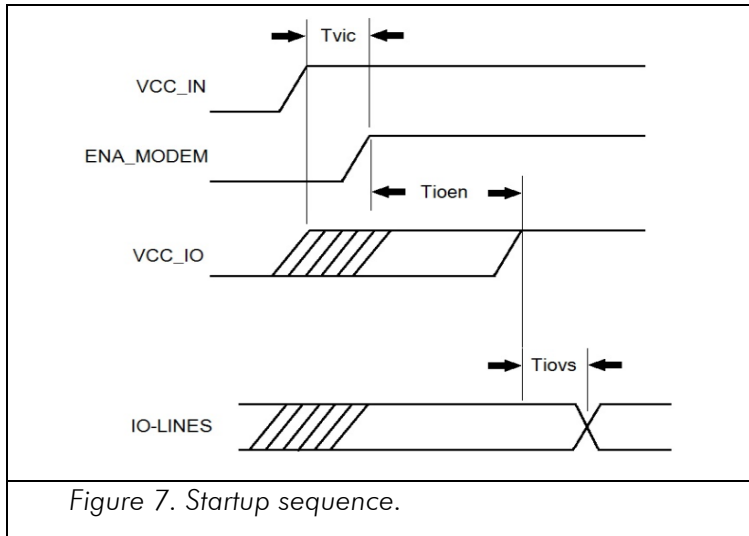

5.2 Shutdown sequence

The following diagram will describe the shutdown sequence.

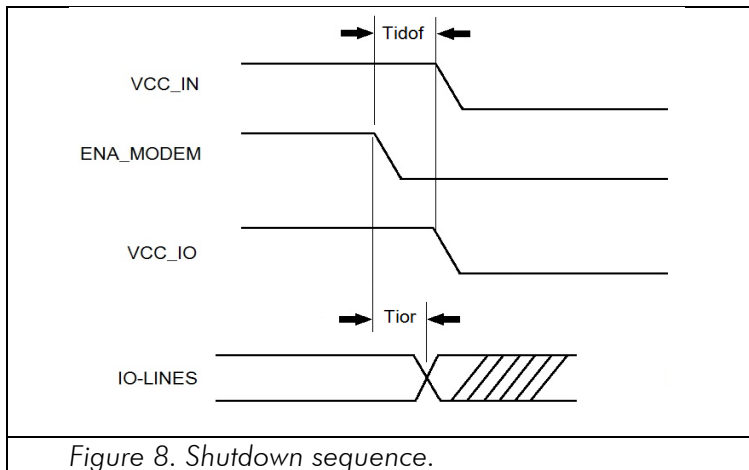

5.3 Stat pin

The STAT pin indicates the status of the device. It can be used to drive a LED using a series resistor. STAT pin drive capability is 10mA (loads the VCC_IO).
The STAT pin has the following behavior.

Blink cycle	Mode
"1" - statically	module is operational "searching for a new frame"
"0" for the endurance of the received frame.	"0" when module is receiving data from air interface. In practical cases will toggle at the frequency of the data packets on the air interface.
"0" statically	Module is in sleep mode
The pin is toggled in transmission interval	Module is sending data Over the Air
Pin is toggled in 1s interval	Module has the connection to Configuration Manager program.
Pin is toggled in 500ms interval	SL Command mode.
Pin is toggled in 250ms interval	Module has detected a fault, fault codes can be read via Configuration Manager program.

Table. Modes of STAT pin.

5.4 Service pin

The SERVICE pin is used to set the UART1 into a known state. Pulling this pin low will activate the service mode and set the UART1 into 38400, n, 8, 1. This is intended for service access of the module, to have a known serial port setting in order to access the module settings.

The pin does not affect any permanent settings, nor does it change the mode of the module. Releasing/ driving the pin high will return serial port 1 into the configured state.

When service pin is used the SL Commands are forced to be ON although they are OFF in settings.

6 TECHNICAL SPECIFICATIONS

SATELLINE-M3-TR3 complies with the following international standards:

EN 300 113-2, ANNEX A

EN 301 489-1

EN 60950-1

FCC CFR47 PART 90

	RECEIVER	TRANSMITTER	Note!
Frequency Range	403...473 MHz		
Tuning range	70 MHz		
Minimum RF Frequency Step	6.25 kHz		
Channel Bandwidth	12.5 kHz / 25 kHz		Programmable
Frequency Stability	<1 kHz		
Maximum Receiver Input Power without Damage	+14 dBm		
Maximum Receiver Input Power without Transmission Errors	-10 dBm		FEC ON
Sensitivity ^{1,2}	-113 dBm @ 25 kHz -116 dBm @ 12.5 kHz		FEC ON
Blocking ^{1,2}	> 86 dB @ 25 kHz > 88 dB @ 12.5 kHz		FEC ON
Intermodulation Attenuation ^{1,2}	> 61 dB @ 25 kHz > 61 @ 12.5 kHz		FEC ON
CO-Channel Rejection ^{1,2}	> -11 dB @ 25 kHz > -10 dB @ 12.5 kHz		FEC ON
Adjacent Channel Selectivity ^{1,2}	> 56 dB @ 25 kHz > 51 dB @ 12.5 kHz		FEC ON
Spurious Rejection	> 67 dB		FEC ON
Typical Power Consumption	730 mW		RX-mode
	SLEEP1: 215 mW		RX-mode
		4.7 W @ 1 W RF out	TX-mode, Continuous, 50Ω
		3.3 W @ 500 mW RF out	TX-mode, Continuous, 50Ω
		2.8 W @ 100 mW RF out	TX-mode, Continuous, 50Ω
		2.6 W @ 100 mW RF out	TX-mode, Continuous, 50Ω
Transmitter Power (programmable)		100 mW, 200 mW, 500 mW, 1 W	TX-mode, 50Ω load
Communication Mode	Half-Duplex		
Adjacent Channel Power		acc. to EN 300 113-1v.1.7.1	TX-mode

Transient Adjacent Channel Power		acc. to EN 300 113-1v.1.7.1	TX-mode
Carrier power stability		< ±1.5 dB	

DATA MODULE		
Timing	UART	
Electrical Interface	CMOS Inputs and outputs referred to IO Voltage processed by user (1.8-3.3V) RTS, CTS, RX, TX, +VCC, GND	
Interface Connector	1.27 mm pitch socket	Samtec 20-pin through hole, CLP-110-02-L-D-K-TR
Data speed of Serial interface	1200 – 115200 bps	
Data speed of Radio Air Interface	19200 bps (25 kHz channel bandwidth) 9600 bps (12.5 kHz channel bandwidth)	
Air Interface Encryption	AES128	Programmable
Data Format	Asynchronous data	
Modulation	4FSK, GMSK	

GENERAL		
Operating voltage	+4.0 VDC	min. ⁵ 4.0V, max. Nominal +5%
Maximum DC Ripple Voltage ³	max. 9 mVpp	DC ≤ f ≤ 1 kHz
	max. 64 mVpp	1 kHz < f ≤ 10 kHz
	mx. 517 mVpp	10 kHz < f ≤ 100 kHz
	max. 2.035 Vpp	f > 100 kHz
Inrush Current, power turned ON ⁴	< 12A, duration < 50 μs	RX-mode
Inrush Current, from RX to TX ⁴	not detected	TX output power 1W
	< 150 mA, duration < 1 ms	TX output power 500 mW
	< 70 mA, duration < 1 ms	TX output power 200 mW
	< 30 mA, duration < 1 ms	TX output power 100 mW
Temperature Range	-20°C ... +55°C	Type Approval conditions
Temperature Ranges	-30°C ... +70°C	Functional
	-40°C ... + 80°C	Storage
Vibration ⁶	≤ 10g	100Hz ≤ f _{vibration} ≤ 1,0 kHz
ESD	±10 kV	Antenna connector. Acc. to EN61000-4-2; 150pF/330Ω
	±8 kV	DTE connector. Acc. to EN61000-4-2; 150pF/330Ω
Antenna Connector	50Ω, HIROSE U.FL compatible	I-PEX 20279-001 -E-01
Construction	PWB with sheet metal EMI shields	
Size L x W x T	57 x 36 x 6.7 mm	
Weight	18g	

Test condition $V_{CC} = 4.0 V$ and $T_A = 25 °C$

¹ According to EN 300 113-1 V.1.7.1 measurement setup

² The measured average of a sample of 19 M3-TR3 modules

³ Higher values exceed the -36 dBm spurious limit at the antenna e.g. EN 300 113-1 requirement.

⁴ Measured using Agilent 1147B current probe and TTI TSX1820P DC power supply

⁵ If 1 W output power is wanted then 4.0 V is the minimum DC voltage

⁶ Functional operation is guaranteed in all directions xyz

6.1 Absolute maximum ratings (*)

Absolute maximum ratings for voltages on different pins are listed in the following table. Exceeding these values will cause permanent damage to the module.

Parameter	Min	Max
Voltage at VCC_IN	-0.3 V	+5 V
Voltage at ENA_MOD	-0.3 V	+6 V
Voltage at VCC_IO	-0.5 V	3.75 V
Voltage at digital inputs (except ENA_MOD)	-0.5 V	3.75 V
Voltage at digital outputs (when no power is applied to unit)	-0.5 V	3.75 V
Antenna port power	n.a.	+14 dBm
Antenna port DC voltage	-10V	+10V

Table. Absolute maximum ratings of module. (* All voltages are referenced to GND)

6.2 DC electrical specifications

Over recommended operating conditions

Parameter	Condition	Min	Max	Units
VCC_IN	4.0V is considered nominal	4.0V ¹	Nominal +5%	V
ENA_modem, Vlow		0.9	VCC_IN	V
ENA_modem, Vhigh		0	0.4	V
Logic input, Vlow	1.8V < VCC_IO < 3.3V	-0.3	< 0.35 * VCC_IO	V
Logic input, Vhigh	1.8V < VCC_IO < 3.3V	0.65 * VCC_IO	3.6	V
Logic output, Vlow	1.8V < VCC_IO < 3.3V	-	0.4	V
Logic output, Vhigh	1.8V < VCC_IO < 3.3V	VCC_IO - 0.4	3.6	V
Logic output, max current	All logic output except STAT pin.	-	4	mA
Logic output, max current, STAT pin		-	12	mA

¹ Minimum voltage if the maximum TX output power (1W/50 Ω load) is wanted. Meets the ETSI requirements on given operating voltage range.

7 DEFAULT DELIVERY VALUES

DEFAULT VALUES OF THE ADJUSTABLE SETTINGS (the user can change these settings later on)		
Setting	Default value	Range
Radio frequency		
Operating TX and RX frequency	438.000 MHz	403 - 473 MHz
Channel Spacing	12.5 kHz	12.5 kHz or 25 kHz
Transmitter Output Power	1 W	100 mW, 200 mW, 500 mW and 1 W
Radio settings		
Radio Compatibility	SATEL 3AS	SATEL 3AS PacCrest-4FSK PacCrest-GMSK PacCrest-FST TrimTalk450s(P) TrimTalk450s(T)
Addressing		
RX Address	OFF	ON/OFF
TX Address	OFF	ON/OFF
Serial port		
Data speed	115200 bps	1200 -115200 bps
Data bits	8	8
Parity bits	None	None, Even, Odd
Stop bits	1	1
Handshaking		Handshaking lines apply to the DATA-port
CTS	TX Buffer State	Clear to send, TX Buffer State
RTS	Ignored	Ignored, Flow Control
Additional setup		
Error Correction, FEC	OFF	ON/OFF
Error check	OFF	OFF, CRC8Partial, CRC8Full, CRC16Full
SL Command Mode	ON	ON/OFF
Repeater Mode	OFF	ON/OFF
TX Delay	0	0 ... 65535 ms
Over-the-Air-Encryption	OFF	ON/OFF
Use Channel List	OFF	ON/OFF
Power Save Mode	OFF	ON/OFF
Add RSSI to Data	OFF	ON/OFF

8 CONSIDERATIONS

8.1 EMI Interferers

The module is designed to be mounted inside a host device. The module is designed to withstand EMI even beyond type approval requirements. However, a small module which is integrated closely to modern high speed electronics is bound to receive some interference.

To make a working integration, consider the following: EMI can enter the module in four ways:

- 1) Via the antenna (radiation from enclosure enters the antenna)
- 2) Radiated disturbances to the coaxial cable
- 3) Radiation from other electronics / cabling directly to the module
- 4) Conducting through the DTE interface (power, control and data lines).

Because the module is shielded and the DTE interface is filtered, the usually worst method of disturbance is via the antenna port, which is easily overlooked in design. Keep in mind that the radio module has a sensitivity of approx. -115 dBm (depends on mode of operation and speed etc.). While the module has an approx. 10 dB S/N requirement, this constitutes, that any signal entering the radio antenna on receive frequency on a level of < -125 dBm (-115dBm-10dB), causes desensitization of the radio on that particular channel.

Example:

An interferer has a level of -100dBm on the frequency 421 MHz. The radio will show an approximate sensitivity of -90dB (-100dBm+S/N requirement 10 dB) on 421 MHz.

Now consider that generic EMC requirements usually have pass/fail criteria of -57dBm (if normalized to the surface of the device). **So there is almost a 70dB gap between generic EMC requirements and co-existence requirements between a high sensitivity narrowband radios.**

To avoid problems of co-existence a good design should apply:

- 1) EMI shielding in enclosure – ambient air interface
- 2) careful layout
- 3) shielding of all digital high speed parts and cables
- 4) Have a clocking plan to avoid clock frequencies causing harmonics on the UHF band of interest.

Number one is to recognize this challenge and act upon it.

SATEL R&D can help in this by participating in design review of the host device, aiming to catch problems early in the design phase.

8.2 Electrostatic discharge

As the module is intended to be embedded in a host application, in a typical use case, the antenna port is the only port of the module directly interface with a surface or contact area subjected to Electrostatic Discharge (ESD).

Thus, the antenna port is the only interface with high level ESD protection. The DTE port also features ESD protection diodes, but is not designed to withstand similar performance as expected from standalone units with enclosures.

Consequently, the module should be subject to ESD handling precautions that typically apply to ESD sensitive components. Proper ESD handling and packaging procedures must be applied throughout the processing, handling and operation of any application that incorporates this module.

The module fulfills the ESD values listed in the following table.

Specification / Requirement	Contact discharge	Air discharge
EN 61000-4-2		
Antenna interface	$\pm 10\text{kV}$	$< \pm 15\text{kV}$
DTE interface	$\pm 8\text{kV}$	-
JEDEC JESD22-A114D (Human Body Model, Test conditions: 1.5 k Ω , 100 pF)		
Module surface	$\pm 1\text{kV}$	n.a.

Table. ESD ratings. Measured Acc. to EN 61000-4-2 specification.

8.3 Using the device in unmanned high reliability applications

The module features software and hardware watchdogs which are incorporated inside the CPU. While we believe that this is a reliable method of keeping the module in operational condition, there are parts of the module that can't be monitored for proper operation to 100%. For example the module chip has a firmware that resides in the chips RAM. The firmware can't be read back or reloaded, without interrupting reception. Hence the module can't reload this automatically by itself without causing breaks in communication.

To avoid the module from ending up in a state where for example the module chip firmware is corrupted for example by ionizing radiation, it is recommended that the controlling system implements some form of watchdog function for the module.

This can be done for example if the system knows that data should be received every second, and no data has been received for a minute – then do a module restart using the ENA_MOD pin or by issuing a restart command, or a cold boot by toggling VCC_IN low and high again.

9 APPENDIX

9.1 SL COMMANDS

Category	Command	Description	Response
Addressing	SL#A?	Show all addresses (RX1, RX2, TX1, TX2)	"xxxx,yyyy,zzzz,vvvv"
Addressing	SL#A=xxxx, yyyy, zzzz,vvvv	Set RX/TX addresses (RX1, RX2, TX1, TX2)	"OK" or "ERROR"
Addressing	SL#I?	Get primary addresses (TX1, RX1)	"xxxx;yyyy"
Addressing	SL#I=xxxx	Set all addresses (RX1, RX2, TX1, TX2) to value xxxx [0000....ffff]	"OK" or "ERROR"
Addressing	SL#P?	Get primary transmit address (TX1) and primary receive address (RX1)	"xxxx;yyyy"
Addressing	SL#P=xxxx;yyyy	Set primary transmit address (TX1) to value xxxx and primary receive address (RX1) to value yyyy [0000....ffff]	"OK" or "ERROR"
Addressing	SL#Q?	Get TX address mode	"0" = TX address OFF "1" = TX address ON
Addressing	SL#Q=x	Set TX address ON/OFF. Values of x are: "0" = TX address OFF "1" = TX address ON	"OK" or "ERROR"
Addressing	SL#R?	Get primary receive address (RX1)	"yyyy"
Addressing	SL#R=xxxx	Set receive addresses (RX1, RX2) to value xxxx [0000....ffff]	"OK" or "ERROR"
Addressing	SL#S?	Get secondary transmit address (TX2) and secondary receive address (RX2)	"xxxx;yyyy"
Addressing	SL#S=xxxx;yyyy	Set secondary transmit address (TX2) to value xxxx and secondary receive address (RX2) to value yyyy [0000....ffff]	"OK" or "ERROR"
Addressing	SL#T?	Get primary transmit address (TX1)	"xxxx"
Addressing	SL#T=xxxx	Set transmit addresses (TX1, TX2) to value xxxx [0000....ffff]	"OK" or "ERROR"
Addressing	SL#W?	Get RX address mode	"0" = RX address OFF "1" = RX address ON
Addressing	SL#W=x	Set RX address ON/OFF. Values of x are: "0" = RX address OFF "1" = RX address ON	"OK" or "ERROR"
ChannelList	SL\$A=1	Go to channel list default channel	"OK" or "ERROR"

ChannelList	SL\$C?	Get number of channels in channel list	decimal number
ChannelList	SL\$C=nn	Set number of channels in channel list. nn = 0...40, 0 clears the whole list	"OK" or "ERROR"
ChannelList	SL\$D?	Get channel list default channel number	decimal number
ChannelList	SL\$D=n	Set channel list default channel, n is channel number	"OK" or "ERROR"
ChannelList	SL\$E=1	Search free channel Modem searches for next traffic-free channel. Listening time of traffic is about 2 seconds Modem shows next free channel by activating command again	"OK" followed by "channel n is free" Value of n is channel number of next free channel on channel list
ChannelList	SL\$F?	Get active channel number	decimal number
ChannelList	SL\$F=n	Set modem to channel number n in channel list	"OK" or "ERROR"
ChannelList	SL\$L?nn	Get channel info. Index nn=[0...(number of channels-1)]	Channel number, Frequency, Channel width, Tx Power For example: "CH 1, 430.150000 MHz, 25.0 kHz, 100 mW\0D"
ChannelList	SL\$L=laa,Nbbbb bb,Fccc.cccccc,W dd.ddd,Peeee< CR>	l = Index field aa = 0...39 //Future reservation 0...255 N = Channel number field bbbbbb = -32767...32767 F = Tx/Rx Frequency field ccc.cccccc = Tx/Rx Frequency in MHz (only numbers or "." allowed, "," is not allowed) W = Channel spacing/width field dddd = 12.5, 20 or 25 (unit is kHz, trailing decimals are tolerated e.g. "25", "25.0", "25.00" and "25.000" are all valid) P = Transmitter power field eeeee = 0...35000 (modem rounds the value to the closest applicable) Note: 0 means "don't care" value for power. <CR> = Carriage return character	"OK" or "ERROR"
ChannelList	SL\$M?	Get status of channel list. 0 = Not in use, 1 = Channel list in use	"0" or "1"
ChannelList	SL\$M=n	Set status of channel list. 0 = Not in use, 1 = Channel list in use	"OK"
ChannelList	SL\$R?	Get listening time (seconds) of Search free channel function	decimal number
ChannelList	SL\$R=n	Set listening time (seconds) of Search free channel function	"OK" or "ERROR"

ChannelList	SL\$S=1	Set channel scanning mode When activated, modem scans channels one by one and saves RSSI readings to memory	"OK" followed by channel/RSSI info For example: "OKCH 6 - 122 dBm, CH 22 -121 dBm, CH 10003 -122 dBm, "
DataPort	SL%B?	Get serial data parameters	baud rate, character length, parity, number of stop bits (for example "38400, 8, N, 1")
DataPort	SL%B=a,b,c,d	Set serial data port parameters. a= "115200", "57600", "38400", "19200", "9600", "4800", "2400" or "1200" (defines baud rate) b="8" (defines character length) c= "N", "O" or "E" (defines parity) d= "1" (defines number_of_stop bits)	"OK" or "ERROR"
Memory	SL**>	Save current settings as permanent settings	"OK" or "ERROR"
Memory	SL*R>	Restore settings to their factory set values	"OK" or "ERROR"
ModemInfo	SL!H?	Get radio HW info	"HW:nnnnn"
ModemInfo	SL!V?	Get modem "type"	Depending on variant, for example "M3-TR3"
ModemInfo	SL%1?	Get arbitrary data stored in memory location 1	If empty data is stored, response = "Undefined", otherwise data and carriage return
ModemInfo	SL%1="data"	Set arbitrary data (max 25 characters) in memory location 1	"OK" or "ERROR"
ModemInfo	SL%2?	Get arbitrary data stored in memory location 2	If empty data is stored, response = "Undefined", otherwise data and carriage return
ModemInfo	SL%2="data"	Set arbitrary data (max 25 characters) in memory location 2	"OK" or "ERROR"
ModemInfo	SL%3?	Get arbitrary data stored in memory location 3	If empty data is stored, response = "Undefined", otherwise data and carriage return
ModemInfo	SL%3="data"	Set arbitrary data (max 25 characters) in memory location 3	"OK" or "ERROR"
ModemInfo	SL%4?	Get arbitrary data stored in memory location 4	If empty data is stored, response = "Undefined", otherwise data and carriage return
ModemInfo	SL%4="data"	Set arbitrary data (max 25 characters) in memory location 4	"OK" or "ERROR"

ModemInfo	SL%D?	Get Modem Type	Depends on model, for example "M3-TR3"
ModemInfo	SL%H?	Get logic hardware version	Hardware info
ModemInfo	SL%S?	Get Serial Number	Serial number of radio modem
ModemInfo	SL%V?	Get firmware revision information	For example "V07.22.2.3.0.2"
OperationMode	SL+S=x	Activate sleep mode "1" turn the modem into a state where it will hold serial interface parts of the module on, wakeup will take approx. 30ms "5" Turns ON Power save mode. "6" Turns OFF Power save mode.	"OK" or "ERROR"
RadioFreq	SL!D?	Get lower limit of frequency band 1	"nnn.nnnnn MHz"
RadioFreq	SL!U?	Get upper limit of frequency band 1	"nnn.nnnnn MHz"
RadioFreq	SL!W?	Get lower limit of frequency band 2	"nnn.nnnnn MHz"
RadioFreq	SL!Y?	Get upper limit of frequency band 2	"nnn.nnnnn MHz"
RadioFreq	SL&F?	Get active frequency	"nnn.nnnnn MHz"
RadioFreq	SL&F=nnn.nnnnn	Set active frequency to nnn.nnnnn MHz	"OK" or "ERROR"
RadioFreq	SL&FR?	Get Rx frequency	"nnn.nnnnn MHz"
RadioFreq	SL&FR=nnn.nnnnn	Set Rx frequency to nnn.nnnnn MHz	"OK" or "ERROR"
RadioFreq	SL&FT?	Get Tx frequency	"nnn.nnnnn MHz"
RadioFreq	SL&FT=nnn.nnnnn	Set Tx frequency to nnn.nnnnn MHz	"OK" or "ERROR"
RadioFreq	SL&W?	Get channel spacing/channel width	"25.0 kHz", "12.5 kHz"
RadioFreq	SL&W=xxxx	Set channel spacing. Value of xxxx is: "1250" for 12,5 kHz "2500" for 25 kHz Before using this command, make sure that active frequency matches new channel spacing	"OK" or "ERROR"
RadioProperty	SL%F?	Get status of Error correction (FEC)	"0" = FEC OFF , "1" = FEC ON
RadioProperty	SL%F=x	Set Error correction (FEC). Value of x is: "1" Set FEC ON "0" Set FEC OFF	"OK" or "ERROR"
RadioProperty	SL%E?	Get status of Error check and Full CRC16 check modes	"0" Error check off "1" CRC8 Partial "2" CRC8 Full "3" CRC16 Full

RadioProperty	SL%E=x	Set Error check and Full CRC16 check modes. Value of x is: "0" Error check off "1" CRC8 Partial "2" CRC8 Full "3" CRC16 Full	"OK" or "ERROR"
RadioProperty	SL%R?	Get region code setting/status	0,0 = Default, 1,1 = US, 1,2 = US & Illegal radio setting combination (TX is disabled)
RadioProperty	SL@D?	Get Tx delay (ms)	For example "0 ms" or "50 ms"
RadioProperty	SL@D=n	Set Tx delay (ms), n is [0...65535]	"OK" or "ERROR"
RadioProperty	SL@E?	Get supported radio compatibility modes.	List of numbers, separated by commas, showing the supported modes: 0=Satel3AS, 1=PacCrest 4FSK, 2=PacCrest GMSK, 3=TrimTalk, 4=TrimTalk Trimble, 5=PCC FST For example: "0,1" indicates that the modem supports Satel3AS and PacCrest 4FSK protocols.
RadioProperty	SL@F?	Get noise level of radio channel	"-xxx dBm"
RadioProperty	SL@M?	Get repeater function	"O" = Repeater OFF(character O) "R" = Repeater ON
RadioProperty	SL@M=x	Set repeater function. Values of x are: "O" = Repeater function OFF(character O) "R" = Repeater function ON	"OK" or "ERROR"
RadioProperty	SL@P?	Get transmitter output power	One of these values "100mW", "200mW", "500mW", "1000 mW"
RadioProperty	SL@P=nnnn	Set RF output power (mW) For example "SL@P=100" sets 100 mW transmitter output power. "100" sets 100 mW transmitter output power. "200" sets 200 mW transmitter output power. "500" sets 500 mW transmitter output power. "1000" sets 1000 mW transmitter output power.	"OK" / "ERROR"

RadioProperty	SL@R?	Get RSSI (Received Signal Strength Indication) of last received message (dBm)	"-nnn dBm", nnn is a decimal value of field strength between -80 dBm and -118 dBm. Value is available 7 s after reception, after that the response is "<-118 dBm". SATELLINE-3AS Epic returns the stronger value of two transceivers.
Radio Property	SL@S?	Get radio compatibility mode	"0" = SATELLINE-3AS "1" = PacCrest-4FSK (Option1) "2" = PacCrest-GMSK (Option2) "3" = Trimtalk450s(P) (Option 3, RX fits PacCrest modems) "4" = Trimtalk450s(T) (Option 4, RX fits Trimble modems) "5" = PacCrest-FST (Option 5)
RadioProperty	SL@S=x	Set radio compatibility mode. Value of x is: 0 = SATELLINE-3AS 1 = PacCrest-4FSK (Option1) 2 = PacCrest-GMSK (Option2) 3 = Trimtalk450s(P) (Option 3, RX fits PacCrest modems) 4 = Trimtalk450s(T) (Option 4, RX fits Trimble modems) 5 = PacCrest-FST (Option5)	"OK" or "ERROR"
Reset	SL@X=n	Reset command. Values of n are: "9" Reset modem	"OK" or "ERROR", then modem resets required blocks.
Test	SL+P=xxxx	Get measured signal strength from remote modem i.e. SL "ping" Value of xxxx [0000...ffff] defines address of remote modem	"OK" followed by RSSI info from remote modem

10 VERSION HISTORY

Version history:

Version:	Date:	Remarks:
0.1	15.05.2013	First Draft.
0.2	27.5.2013	Modified by ML
0.2	30.5.2013	Reviewed by R&D
0.3	3.6.2013	Modified by ML
0.3	11.6.2013	Reviewed by JPu
0.4	12.6.2013	new draft version 0.4 by ML
0.4	17.06.2013	Reviewed by R&D
0.4	17.06.2013	Modified by ML
0.4	18.06.2013	Reviewed by R&D
0.5	18.06.2013	Modified by KSu
0.6	19.06.2013	Modified by ML
0.7	23.08.2013	Updated information in the table in paragraph 1.4 and specification tables, updated SL command response for SL!H? command.
1.0	03.10.2013	Added Power save mode description, updated Timing parameters table (in chapter 5). General modifications.
1.1	01.11.2013	Added RF Exposure warning and host device labeling requirements.
1.2	09.01.2014	Modified RF Exposure warning