



Quick Guide



Barcode Printer MB400

Thank you for your purchase of the SATO barcode printer MB400. Make sure to read this operation manual and keep it in a handy place.

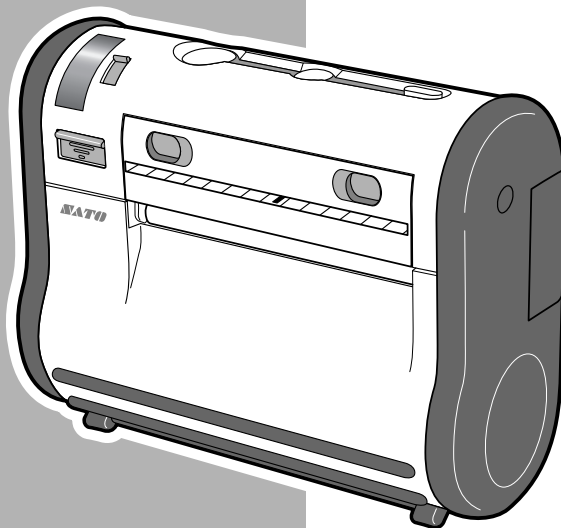



Introduction

Thank you for your purchase of the SATO barcode printer MB400.

This manual helps first time users understand the basics of the MB400 in a short period of time.

To get the most out of the functions of the MB400, make sure to read this manual carefully.

Warning!

1. This manual may not be reproduced whole or in part without prior consent from SATO.
2. The information in this manual is subject to change without notice.
3. Despite this manual has been created to be as accurate as possible, contact the shop or the dealer where you purchased this product if you find any errors or mistakes.



This device complies with Part 15 of the FCC Rules. Operation is subject to the following two conditions: (1) This device may not cause harmful interference, and (2) This device must accept any interference received, including interference that may cause undesired operation.



NOTE : This equipment has been tested and found to comply with the limits for a Class B digital device, pursuant to Part 15 of the FCC Rules.

These limits are designed to provide reasonable protection against harmful interference in a residential installation. This equipment generates use and can radiate radio frequency energy and, if not installed and used in accordance with instructions, may cause harmful interference to radio communications. However, there is no guarantee that interference will not occur in a particular installation. If this equipment does cause harmful interference to radio or television reception, which can be determined by turning the equipment off and on, the user is encouraged to try to correct the interference by one or more of the following measures:

- Reorient or relocate the receiving antenna.
- Increase the separation between the equipment and receiver.
- Connect the equipment into an outlet on a circuit different from that to which the receiver is connected.
- Consult the dealer or an experienced radio/TV technician for help.





Features of the MB400

With compact and lightweight body combined with high performances, this printer prints barcodes clearly on various types of thermal paper.

Excellent Printing Performance

Not only does this printer print barcodes clearly, but it can also enlarge and print various types of fonts and Kanji characters in a free layout.

Durable and Easy to Use

This printer is also superb in durability, as it has been designed with the premises of printing barcodes. Also, special consideration has been taken so that the printer can be easily cleaned everyday.

Dispenser Function

As a portable printer, this printer can easily print and dispense labels to enable the application of labels at site.





Preparation/Operation

Table of Contents

1. Safety Precautions	5
Markings and Symbols	5
Precautions in Use	11
2. Unpacking	12
3. Part Names	13
Name and Function of Operating Parts	15
4. Before Starting	16
Charging the Battery Pack	16
Installing and Removing the Battery Pack	18
Setting Labels	20





Safety Precautions

In this section, safety precautions about printer operation are explained to ensure proper care and usage. Make sure to read these carefully before using your printer.

Markings and Symbols

The following symbols or markings are used in this quick guide and on the printer so that you can properly use the printer, and to prevent any damage to property, harm or injury to yourself and others. Make sure to read their explanations carefully to familiarize yourself with their meanings.

Safety Precautions

	Warning	This symbol indicates information that, if ignored or applied incorrectly, creates the danger of death or serious personal injury.
	Caution	This symbol indicates information that, if ignored or applied incorrectly, creates the possibility of personal injury or property damage.



Symbol example

- The triangle (\triangle) indicates something you should take absolute care when doing. The cautions are indicated concretely within the symbol. The symbol on the left indicates caution with electric shock.
- A diagonal line within a circle ($\textcircled{/}$) indicates something you should not do. The symbol on the left indicates you should not try to take the unit apart.
- A black circle (\bullet) indicates something you need to do. The symbol on the left indicates you should unplug the unit from the wall outlet.





Safety Precautions



Warning



Liquids

Do not place any containers with water or chemicals, such as flower vases or cups, as well as small metallic objects near the printer. Continued use creates the danger of fire or electrical shock.

* If any of these should fall into the printer, immediately turn off the power and contact your nearest dealer or service center.



Foreign Matter

Do not drop or insert metallic or flammable objects into the openings on the printer (such as outlets for cables). Continued use creates the danger of fire or electrical shock.

* If any of these should fall into the printer, immediately turn off the power and contact your nearest dealer or service center.



Dropping and Damage

Do not use if the product has been dropped or damaged. Continued use creates the danger of fire and electrical shock.

* Should the printer ever fall or otherwise become damaged, immediately turn off the power and contact your nearest dealer or service center. Continued use creates the danger of fire or electrical shock.



Abnormal Conditions

Do not use the printer if it is emitting smoke or strange odors. Continued use creates the danger of fire and electrical shock.

* Immediately turn off the power and contact your nearest dealer or service center for repairs. Do not try to service the printer by yourself.

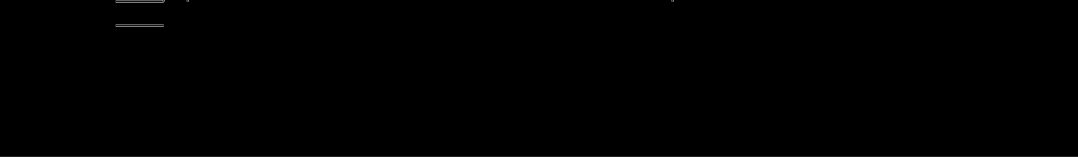

Warning



Disassembly

Never try to take the unit apart or modify it in any way. Doing so creates the danger of fire or electrical shock. Contact your nearest dealer or service center for repairs.



Battery Pack

Never try to take apart the battery pack or modify it in any way such as with a solder. Doing so creates the danger of heating, fire or explosion.



Never expose the battery to direct flame, throw it into fire, or take any actions that may lead to shorting. Doing so creates the danger of heating, fire or explosion.



Never charge the battery pack with any other battery charger except for the specified one. Doing so creates the danger of heating, fire or explosion.

Safety Precautions





Safety Precautions

Safety Precautions



Warning



AC Adapter / Battery Charger (Optional)

Use only the specified voltage. Using a different voltage may create the danger of fire or electrical shock.



Never use the battery charger with any other battery pack except for the specified one.
Doing so creates the danger of fire and electrical shock.



Never cut or damage the power cord. Also, never place heavy objects on, set fire to or pull the power cord.
Doing so creates the danger of fire and electrical shock.



Never use a damaged cord.
Doing so creates the danger of fire and electrical shock.
* Contact your nearest dealer or service center.



Never modify, excessively bend, twist, or pull the power cord.
Doing so creates the danger of fire or electrical shock.

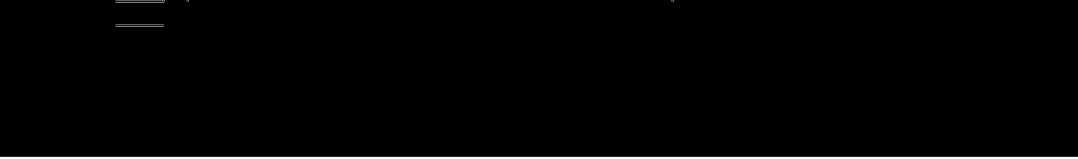

Warning

Location



Do not locate the printer in areas subjected to high humidity or dew.

Doing so creates the danger of electrical shock.

* If dew forms inside the printer, immediately turn off the power and do not use it until it has dried up.

Power



Never operate the power switch, replace the battery pack or unplug the AC adapter or battery charger with wet hands. Doing so creates the danger of electrical shock.

Thermal Head



The thermal head becomes very hot after printing. Make sure not touch it with bare hands.

Doing so creates the danger of injury, burns and electrical shock.

* Take care when replacing labels after printed and when cleaning to avoid burn.



Do not touch the edge of the thermal head with bare hands. Doing so may cause injury.

* Take care when replacing labels or cleaning to avoid injury.



Do not try to replace the thermal head by yourself.

Doing so creates the danger of injury, burns or electric shock.





Safety Precautions



Warning



Easy Cutter

This part contains a blade. Do not touch with your bare hands, as this may lead to injury.



Replacing the Battery Pack

Use only the specified battery pack.



When replacing the battery pack, make sure to install the pack with the poles (+) and (-) facing the correct direction. Incorrectly replacing the battery can rupture the battery and create injury and damage to surrounding areas due to leakage.



When disposing of old battery packs, make sure to contact your nearest dealer or service center.



Not using the printer for a long time

Remove the battery pack from the printer and unplug the AC adapter from the wall outlet.



Maintenance and Cleaning

For safety during maintenance and cleaning, make sure to remove the battery pack and the AC adapter from the printer.



Precautions in Use

Do not place the printer in locations exposed to direct sunlight or places of high temperatures. Especially on the dashboard inside a car during summer periods, as it can get very hot.

Use only the specified cable to connect to the external input terminal. When connecting external equipment via the external input terminal, make sure to use the specified cable for connection. If you have any questions, consult with your nearest dealer or service center.

Make sure to use the specified optional equipment. Using other equipment besides the ones specified may create damage.

Make sure to use the specified labels. Using other types of labels besides the ones specified may cause the print head failure or faulty printing.

Safety Precautions

Bluetooth specification.

FCC Caution:

Changes or modifications not expressly approved by the manufacturer for compliance could void the user's authority to operate the equipment.

IC(Industry Canada) Caution:

The term "IC:" before the radio certification number only signifies that Industry Canada technical specifications were met.

"Operation of this device is subject to the following two conditions:(1)this device may not cause interference,and (2)this device must accept any interference,including interference that may cause undesired operation of the device."

"The installer of this radio equipment must ensure that the antenna is located or pointed such that it does not emit RF field in excess of Health Canada limits for the general population;consult Safety Code 6,obtainable from Health Canada's website www.hc-sc.gc.ca/rpb"

CE Caution:

Hereby,SATO CORPORATION,declares that this MB400 is in compliance with the essential requirements and other relevant provisions of Directive 1999/5/EC.



If you want to get a copy of the original Declaration of Conformity of our products which relates the R&TTE,please contact to web address :www.barcodesato.com





Unpacking

Unpacking

After opening the box, make sure that all the printer's accessories are included. If there are any accessories missing, contact your nearest dealer or service center.

- ① **Printer**
- ② **Battery pack (standard or optional)**
- ③ **Shoulder belt**
- ④ **Quick guide**

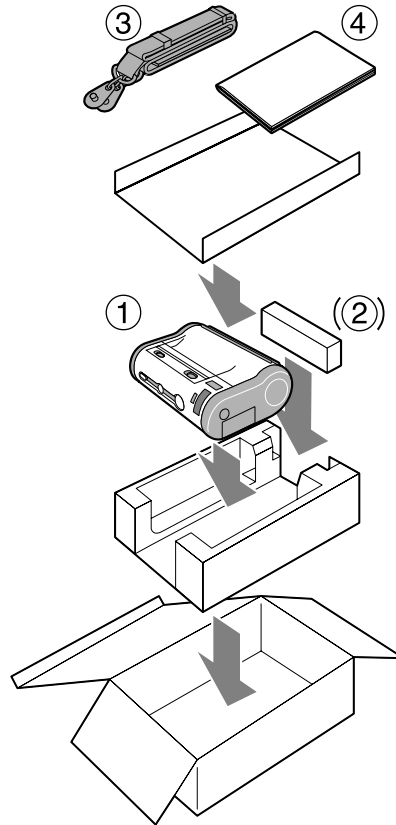

Other accessories



Cable lock
Attached to the interface connector.

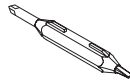

Adjustment driver
Located inside the printer (under the label feed area)



Part Names

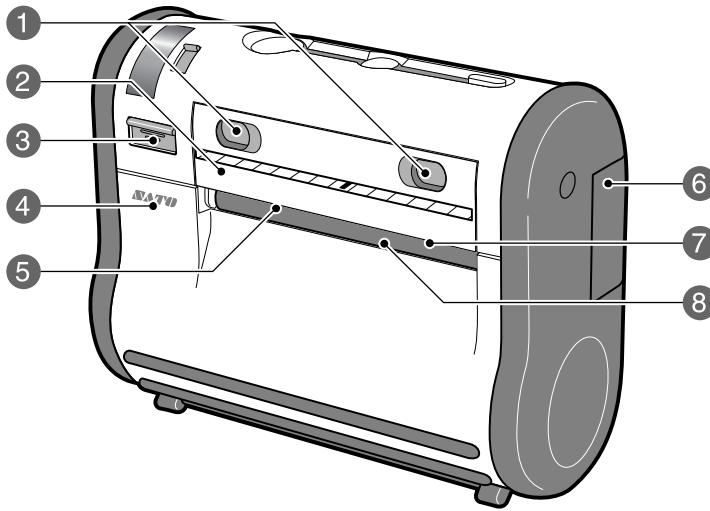

Part Names

- ① Dispense/Continuous switch lever**
For switching the print mode (dispense/continuous).
- ② Dispenser unit**
Moved when the Dispense mode is selected.
- ③ Front cover Open/Close lever**
For opening and closing the front cover
- ④ Front cover**
Opened for setting labels.

- ⑤ Easy cutter**
Used for cutting printed labels.
- ⑥ Battery cover**
The battery pack is inserted here.
- ⑦ Label ejection**
The printed label comes out from there.
* Varies depending on the print mode.
- ⑧ Platen roller**



Part Names

Part Names

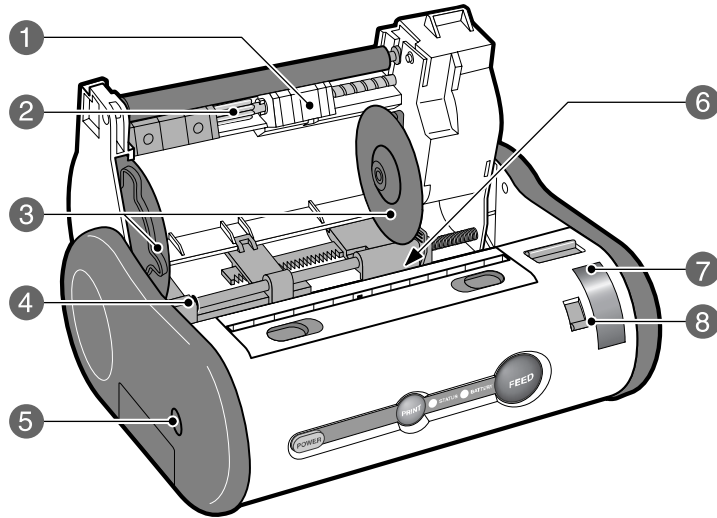

- ① Label sensor**
Position adjusted to the label size being used.
- ② Label sensor adjustment dial**
For adjusting the location of the label sensor.
- ③ Label guide**
Adjusted to the label size being used.
- ④ O ring**
For fixing the label guide.
- ⑤ Shoulder belt hook**
For attaching the shoulder belt used when hanging the printer on shoulder.
- ⑥ Adjustment driver**
(supplied accessory)
- ⑦ IrDA filter**
The IrDA receiving element is located inside.
- ⑧ IrDA adjustment lever**
Used for changing the angle of the IrDA receiving element.



● Operation part names

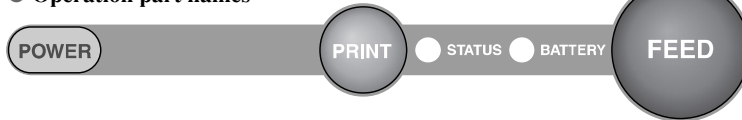

POWER key

For turning the power on and off.

PRINT key

For setting the printer to online or offline.

FEED key

For feeding labels.

STATUS LED indicator

Indicates the status of the printer.

Battery LED indicator

Indicates the status of the battery.

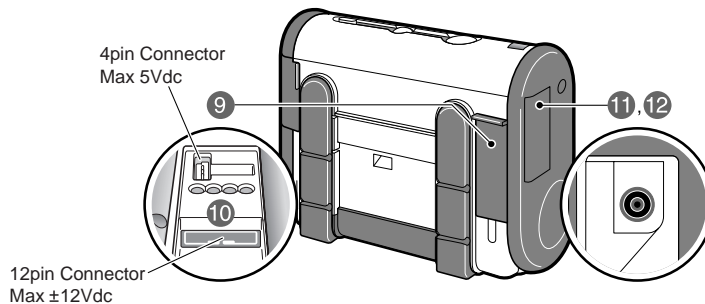

9 Interface cover

Cover for the interface connector. (The cable lock is included.)

10 Interface connector (RS-232C)

Used for connecting to a computer.
Signal: Low Level (-3V ~ -12V)
High Level (+3V ~ +12V)

11 DC input jack cover

For covering the DC input jack when not in use.

12 DC input jack

Used for connecting the AC adapter.
Used the UL Listed Class2 AC Adapter or I.T.E Power Supply marked "LPS" SATO'S Model APR400 (UL Listed I.T.E Power Supply, SAC, Model SA60-15) rated output 15Vdc, 3600mA.





Before Starting

Charging the Battery Pack

Before Starting

You can recharge the battery pack by inserting it into the battery charger (optional).

- 1 Plug one end of the AC adapter into the battery charger and the other end into the wall outlet.

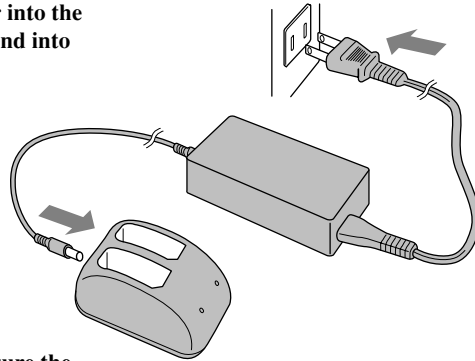

- 2 Insert the battery pack. Make sure the connector on the battery pack is facing down and insert it into the charger.
 - The CHARGE indicator will light in red when charging starts.
 - The CHARGE indicator will light in green when charging is complete (Fully charged).
- 3 When charging is complete, remove the battery pack from the charger.

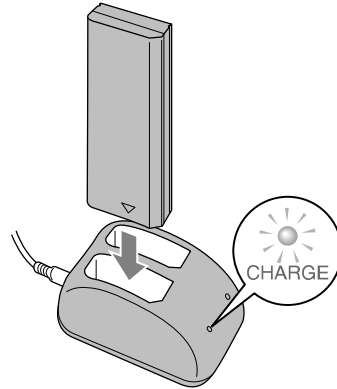

For Battery Charger: Model CHG400 is the specified battery charger for battery pack Model BAT400. Use the UL Listed class2 AC Adapter or Power Supply marked "LPS", SATO'S Model ACH400 (UL Listed I.T.E Power Supply, SAC, Model SA60-19), rated output 19Vdc, 3200mA.



Notice

- If the indicator on the charger does not light up, make sure that the battery pack is firmly attached to the charger. The battery may not charge, if not firmly attached.
 - If an already charged battery pack is inserted into the charger, the CHARGE indicator will turn red once (charging), however it will soon change to green (fully charged).
 - If charging a battery pack that has not been used for a long period, the indicator on the charger will flash for a while. This does not indicate an error, and you can continue charging as it is. If the indicator continues to flash for a long time while charging, replace the battery pack with a new one.
 - The battery pack can be charged up to 300 times (during use in regular temperatures). If the battery pack is fully charged but soon runs out, replace the battery pack with a new one.
- * Write down the date of purchase of the battery with a marker on the sticker attached to battery pack as a guideline of the number of times the battery can be recharged (the life of the battery). (For example: Date of purchase: Jun. 1st, 2002.)
- 
- The battery pack cannot be used when using the AC adapter.
If the AC adapter jack is plugged into the printer when using the battery, the power will be reset.
(If there is any remaining print data, it will be lost.)

Charging time

The duration of one battery pack from empty until fully charged is about 90 minutes. For two battery packs about 130 minutes.
(The charging time varies depending on the environment.)



Danger of explosion if battery is incorrectly replaced.

Replace only with the same or equivalent type recommended by the manufacturer's instructions.

Dispose of used batteries according to the manufacturer's instructions.





Before Starting

Installing and Removing the Battery Pack

Before Starting

- 1 Open the battery cover in the direction of the arrow.

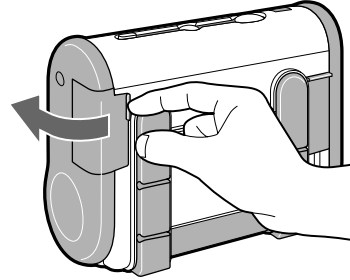

- 2 Insert the battery pack.

Insert the battery pack with the connector facing towards the end.

* Insert the battery all the way in until the lock clicks into place.

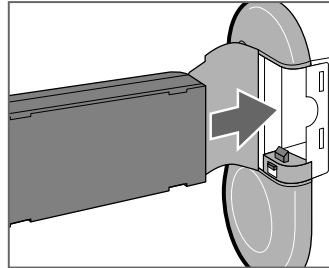

- 3 To remove the battery pack, press down release the lock. Then pull the battery pack out placing your finger into the notch



Take care not to drop the battery pack when removing it. The battery pack may be damaged if it is dropped.

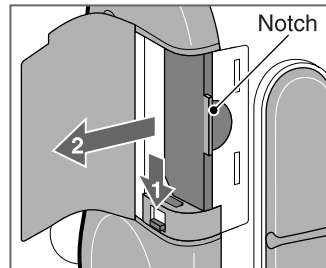



Battery Status

1. Battery near end

When the battery is getting low, the battery near end is detected and the BATTERY LED indicator lights up in orange. The keys can still be operated, however the battery should be recharged.

2. Low Battery Error

When the battery gets empty, a low battery error is detected and the BATTERY LED indicator lights up in red. The keys cannot be operated, and after 30 seconds the power automatically turns off. Make sure to recharge the battery.

Status	BATTERY LED indicator
Battery near end	Light (orange)
Low battery error	Light (red)

The BATTERY LED indicator does not light up during printing or an error, even if battery near end or low battery error has been detected.

Caution!

- Make sure to turn the power off when removing or replacing the battery pack.
- If you do not plan to use the printer for long period of time, make sure to remove the battery pack.
If not removed, the battery may get over discharged and may not be recharged.
- Do not store the battery in places of high temperature.
- BAT400 is the specified battery pack for the Barcode Printer MBXX series.
- Make sure to charge the battery with specified battery charger (Model CHG400).
- Danger of explosion if battery incorrectly replaced.
- Replace only with the same or equivalent type
- Dispose of used batteries according to the manufacturer's instructions.



Before Starting

Before Starting

Setting Labels ... The method of setting the labels may vary depending on the print mode.

[Continuous mode]

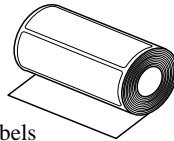

Labels

- 1 Press the cover Open/Close lever in the direction of the arrow to release the front cover lock.

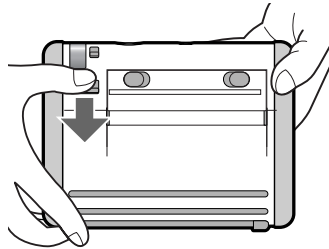

- 2 Slide the front cover to open. Hold the front cover and slide it in the direction of the arrow until it stops.

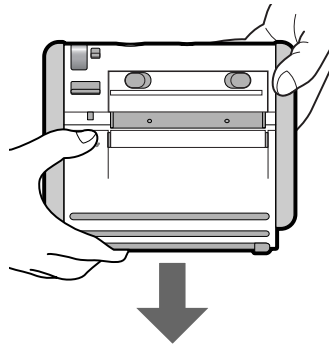



- 3 Open the front cover in the direction of the arrow.

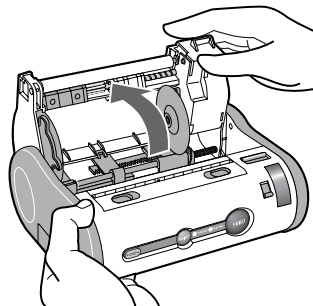

Before Starting

- 4 Insert the label roll on the label guide boss inside the front cover.

- Press the tab for adjusting the label guide (right), and adjust the guide to the width of the labels to be used.

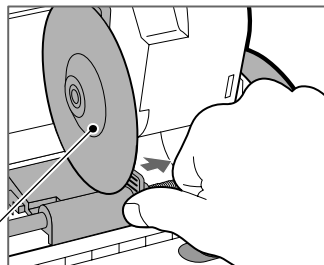

Label guide boss

- Firmly insert the label roll on the bosses on the left and right of the label guide.
- * Move the label roll to make sure that it is firmly set on the bosses.

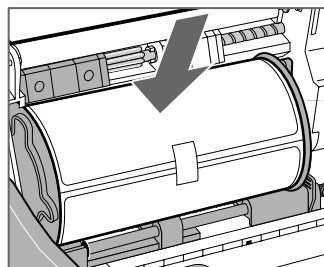

(Continued to page 22)



Before Starting

Setting Labels ... The method of setting the labels may vary depending on the print mode.

Before Starting

[Continuous mode] (Continued from page 21)

- 5 After peeling the lead tape on the roll, take the leading edge of the first label on the roll and pull it out via the platen roller. Then turn the front cover in the direction of the arrow.

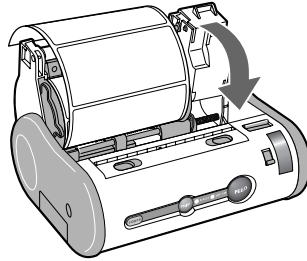

- 6 Close the front cover in the direction of the arrow.

* Press the front cover until the cover Open/Close lever clicks.

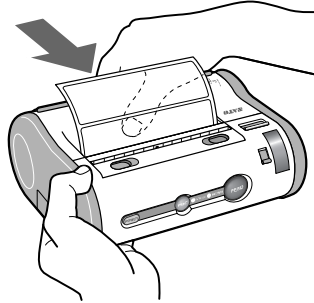



If the cover is not properly locked, the warning seal in the front cover Open/Close lever can be seen.

* Never print with the cover not properly locked.

Front cover Open/Close lever

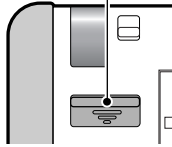

Locked

Warning seal

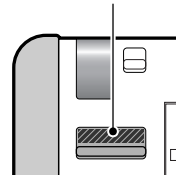

Not locked

Before Starting





AVATO



Q00322002

