

Operating instructions

DRC-MP receiver (D1FH - with frequency hopping)

Valid only in conjunction with DRC-10 or DRC-J operating instructions

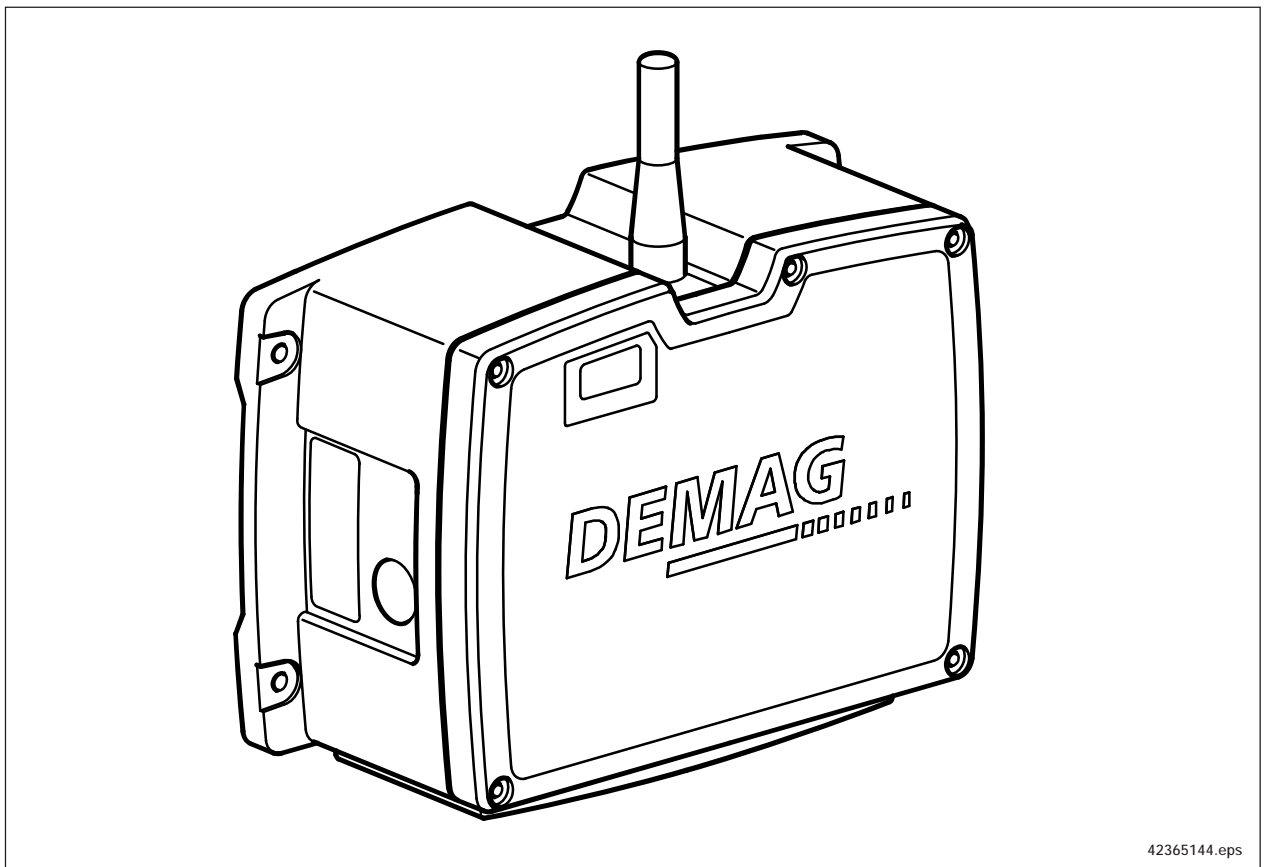

Contents

1	Foreword	3
1.1	Copyright	3
1.2	Customer service	3
1.3	Liability for Defects	4
1.4	Limitations of liability	4
1.5	Definitions	5
2	Safety instructions	6
2.1	Symbols	6
2.2	Appropriate use	6
2.3	Inappropriate use	8
2.4	Basic information on safety	8
2.5	Safety instructions for assembly and disassembly	9
2.6	Safety instructions when first putting into service after completing installation	9
3	General description	10
3.1	Transmitter/receiver interface	10
3.2	Transmission method	10
4	Selection of unit	12
4.1	DRC-MP scope of delivery	12
4.2	Available radio transmitters	12
4.3	Accessories for crane identification	12
4.4	Cable set	12
4.5	Offset aerial	12
5	Putting the DRC-MP radio receiver into operation for the first time	13
5.1	Assembly and connection of the radio receiver	13
5.2	Assignment of terminals and functions	15
5.3	Explanation of radio receiver LED's	15
5.4	Radio receiver connection diagram (Connection example with a 42-pole connection cable)	16
5.5	Activating and adjusting special functions	17
5.5.1	BE function general	18
5.5.2	Feedback channel information	20
5.5.3	SGDM function	21
5.5.4	LIFT-FAST relay	22
5.5.5	F1 / F2 relays programmable as `non-latching` or `latching` relay	23
5.6	Function check after installation	23
6	Block wiring diagram (Example with a 42-pole connection cable)	24
7	Technical data	25
8	Dimensions	26
9	International postal registration	27
	EC conformity declaration	28

Accompanying documents:

DRC -10 operating instructions	214 920 44	720 IS 975
2 DRC-J operating instructions	214 975 44	720 IS 975

1 Foreword

You have purchased a Demag product.

These operating instructions are designed to provide the owner with appropriate instructions for safe and correct operation and to facilitate maintenance.

Every individual given the task of transporting, installing, commissioning, operating, maintaining and repairing our products and additional equipment must have read and understood

- the operating instructions
- the safety regulations and
- the safety instructions in the individual chapters and sections.

The operating instructions must be available to the operating personnel at all times in order to prevent operating errors and to ensure smooth and trouble-free operation of our products.

1.1 Copyright

These operating instructions must be treated confidentially. They should only be used by authorized personnel. They may only be entrusted or made available to third parties with the prior written consent of Demag.

All documents are protected within the sense of copyright law.

No part of this documentation may be reproduced, utilized or transmitted without specific prior consent. Infringements are an offence resulting in obligatory compensatory damages.

All industrial rights reserved.

1.2 Customer service

Our after-sales service will provide you with all technical information on Demag products and their systematic application.

Should you have any questions regarding our products, please refer to one of our after-sales service stations, the relevant representative or the manufacturer.

Kindly quote the serial or order number (see test and inspection booklet, load capacity plate on the crane) in any correspondence or for spare part orders.

Specifying this data ensures that you receive the correct information or the required spare parts.

The relevant after-sales service station of Demag is specified for example on the back page of the rope hoist test and inspection booklet.

1.3 Liability for Defects

These operating instructions must be read carefully before installing and putting the radio control into operation.

We assume no liability for any damage and malfunctions resulting from failure to comply with the operating instructions.

Any liability claims for defects must be made by quoting the order number immediately on detecting the defect.

Any liability claims for defects are void in the event of:

- inappropriate use,
- faulty devices or equipment connected or attached to the system which are not part of our scope of supplies and services,
- use of non-genuine spare parts and accessories,
- refurbishment or modification of the product unless approved in writing by Demag.

Wearing parts are not subject to liability for defects.

1.4 Limitations of liability

All technical information, data and instructions for operation contained in these operating instructions were up-to-date on going to print and are compiled on the basis of our experience and to the best of our knowledge.

We reserve the right to incorporate technical modifications within the scope of further development of the radio control which is the subject of these operating instructions.

Therefore, no claims can be derived from the information, illustrations and descriptions contained in these operating instructions.

The descriptions and illustrations contained in this documentation do not necessarily correspond to the scope of delivery or any subsequent spare part delivery, either; the drawings and illustrations are not to scale.

Only documentation belonging to the actual order is valid.

We assume no liability for damage and malfunctions caused as a result of operating errors, non-compliance with these operating instructions or inappropriate repairs and maintenance.

We expressly point out that only genuine Demag spare parts and accessories approved by us may be used. Accordingly, this also applies to other manufacturers' parts supplied by us.

For safety reasons, the fitting and use of spare parts or accessories which have not been approved and unauthorized modification and conversion of the product are not permitted and exempt us from any liability for damages resulting therefrom. With the exclusion of any further claims, we are liable for any defects or omissions on our part in the products or documentation supplied within the scope of the liability obligations entered into in the original contract. Any further claims, in particular any and all claims for damages, are excluded with the exception of legal claims in accordance with product liability legislation.

1.5 Definitions

Owner

Owners (employer, company) are defined as a person who owns a radio control and who uses it appropriately or allows it to be operated by suitable and instructed persons.

Operating personnel/operator

Operating personnel or operators are defined as persons entrusted by the owner of the radio control system with the operation of the radio control.

Specialist personnel

Specialist personnel are defined as persons assigned by the owner of the radio control system to carry out special tasks such as installation, setting-up, maintenance and fault elimination.

Qualified electrician

Qualified electricians are defined as persons who, owing to their technical training, knowledge and experience of electrical installations as well as knowledge of the relevant standards, codes of practice and regulations, are able to assess the tasks given to them and to identify and eliminate potential hazards.

Trained person

Trained persons are defined as persons who have been instructed and trained for the tasks assigned to them and on the possible hazards resulting from incorrect handling and who have been informed about the required protective devices, protective measures, relevant regulations, codes of practice, accident prevention regulations and operating conditions and who have proven their qualifications.

Experienced technician

Experienced technicians are defined as persons, who, owing to their technical training and experience, have sufficient knowledge of radio controls and are familiar with the relevant national industrial safety regulations, codes of practice, accident prevention regulations, directives and generally accepted engineering standards enabling them to judge the safe operating condition of radio control systems.

Assigned expert engineer (in the Federal Republic of Germany according to BGV D8, § 23, for determining the S.W.P.)

An assigned expert engineer is defined as an experienced technician specifically assigned by the manufacturer to determine the remaining duration of service (service life) of rope hoists (S.W.P. = safe working period) and to carry out a general overhaul of rope hoists.

Authorized expert engineer (in the Federal Republic of Germany according to BGV D6, § 28)

In addition to the expert engineers of the Technical Supervisory and Inspection Board, an authorized expert engineer for the inspection of radio control systems is defined as an expert engineer authorized by the Industrial Employers' Mutual Insurance Association.

Radio control system

Radio control systems are systems used for controlling the lifting, lowering and travel motions of loads on cranes, travelling hoist units, machinery and installations.

2 Safety instructions

2.1 Symbol description

These symbols are used to warn against potential safety hazards or causes of damage or provide useful information.



Hazard warning

This symbol appears in the operating instructions next to all instructions relating to safety at work wherever a potential danger to life and limb exists.

Follow these instructions at all times and be particularly vigilant and cautious.

Pass on safety instructions to all persons entrusted with working on the product including the power supply.

In addition, observe all general safety regulations at all times.



Warning against dangerous electrical voltage

Contact with live parts can result in immediate death. Protective covers (e.g. covers and enclosures) marked with this sign may only be opened by qualified electricians. Before opening, all relevant operating, control, feed or other voltages must be disconnected.



Operating hazard for the installation

This symbol in the operating instructions indicates all warnings which, if not complied with, may result in damage to the product.

2.2 Appropriate use

The DRC-MP radio receiver is intended to be used as a receiver unit for DRC-10 and DRC-J radio transmitters. The scope of functions is preferably designed for the wireless control of crane installations, travelling hoist units, chain and rope hoists, transfer carriages and similar applications.

Thus for these applications, the conventional permanently wired control equipment (control pendant) can be dispensed with. The operator can position himself as required. He can freely move loads and control equipment from a safe distance in line with the local conditions.

The unit to be controlled must be provided with a contactor control system.

The outputs of the DRC-MP radio receiver are relay contacts that are connected to the contactor control system of the system to be controlled. The DRC-MP radio receiver is supplied by the control voltage source of the contactor control system. The voltage and frequency of the contactor control system must match the data specified on the rating plate of the DRC-MP radio receiver. The specified power consumption of the receiver must also be taken into account.

DRC-MP radio receivers are exclusively intended for single-transmitter operation; i.e. there is always a clear assignment to a specific transmitter (DRC-10 or DRC-J).

DRC transmitters and receivers meet the requirements of the standards and regulations listed in the EC conformity declaration. The specified EC conformity declaration is an integral part of the relevant operating instructions.

Transmitters and receivers of the DRC range can be operated without any registration or operating fee. The benefits that this provides for the user are also utilised by some other manufacturers of devices for communications and telemetry applications. The consequence of this is that the relevant approved frequency ranges may be used by many transmitters at the same time, depending on the time and location.

The transmission method used by Demag is designed for the most robust and interference-resistant radio transmission between the transmitters and receivers of the DRC range.

The state-of-the-art transmission method is provided with technical features (e.g. frequency hopping) which are intended to ensure a minimum of conflicts for radio operation together with other transmitter and receiver devices which use the same frequency range.

Despite all of the technical precautions taken by Demag, it cannot be entirely excluded that the transmission characteristics of other radio systems are impaired, in particular devices supplied by other manufacturers that use the same frequency range, or that the transmission characteristics of the system supplied by Demag are negatively affected. In such cases, interference or radio connection interruptions may occur, which disrupt the communication and function of a system supplied by Demag or other manufacturers. Such impairment or interference does not constitute a defect on the part of DRC transmitters and receivers. Demag will only accept liability for wilful or grossly negligent behaviour on its part.

The number of transmitters that operate without any interference in a given area depends on the relevant radio solution design of all systems and the selectivity of each individual system.

If this limit is exceeded continuously or for certain periods, additional technical measures may be necessary in order to ensure simultaneous and interference-free operation of the radio systems. Whether and to which extent such measures are required can only be determined by means of suitable measurements on site or when the system is put into operation. Demag is not responsible for such additional technical measures.

Radio remote control systems of the DRC range are exclusively intended for single-transmitter operation; i.e. there is always a clear assignment between a specific transmitter and the corresponding receiver.

Radio remote control systems of the DRC range may only be operated when in perfect working order by trained personnel in accordance with the relevant safety and accident prevention regulations. This also includes compliance with operating and maintenance conditions specified in the operating instructions.

In Germany, the owner of a crane installation with radio control system is responsible for compliance with accident prevention regulations BGV D6.

For appropriate use, the information in the operating instructions for the radio transmitter used (DRC-10/DRC-J) and the machine/crane installation to be controlled must be complied with in addition to the information contained in these operating instructions (see accompanying documents, page 2).

Serious personal injury or damage to property may occur in the event of:

- unauthorized removal of covers,
- inappropriate use of the product/system,
- incorrect operation,
- insufficient maintenance,
- working on live parts.

2.3 Inappropriate use

Certain work and practices are prohibited when using the product as they may involve danger to life and limb and result in lasting damage to the product, e.g.:

- Manipulating electrical equipment
- Connecting the unit to power supply with voltage or frequency other than those specified on the type plate
- Non-compliance with specified mounting positions
- Non-compliance with the max. permissible ambient temperature.

Other inappropriate applications may be caused by non-compliance with the information in the operating instructions for the transmitter and for the system/machine to be controlled.

2.4 Basic information on safety

Persons under the influence of drugs, alcohol or medicines which affect reactions must not install, operate, put into service, maintain, repair or disassemble the product. Any conversions and modifications to the installation must comply with the safety requirements. Work on electrical equipment may only be carried out by specialists in accordance with electrical regulations. In the event of malfunctions, the product must be shutdown, switched off and the relevant main switches locked immediately.

Malfunctions must be eliminated immediately.

National accident prevention regulations and codes of practice and general safety regulations must be observed when operating our products. Important information and instructions are marked by corresponding symbols. Follow these operating and safety instructions to avoid personal injury and damage to machinery. The operating instructions must be kept available at the place where the product is in use at all times.

They include significant aspects and appropriate excerpts from the relevant guidelines, standards and regulations. The owner must instruct his personnel appropriately. If the safety instructions given are not observed in any way, personal injury or even death can result.

Observe general statutory and other obligatory regulations relating to accident prevention and environmental protection and basic health and safety requirements in addition to those included in these operating instructions.

Such requirements may also relate, for example, to the handling of hazardous materials or the provision/wearing of personal protection equipment.

Comply with these regulations and general accident regulations relevant for the place at which the product is used and follow the instructions therein when working with the product.

The product may still constitute a danger to life and limb if it is not installed, operated, maintained or used appropriately by personnel which have not been trained or specially instructed.

The safety instructions must, if required, be supplemented by the owner with instructions and information (e.g. factory regulations) relating to organization of work, working procedures, operating personnel, etc. Supervising and reporting obligations as well as special operating conditions must also be taken into consideration.

Personnel assigned to working with the product must have read the operating instructions and the safety instructions.

All activities relating to the product which are not described in the operating instructions may only be carried out by specifically trained specialist personnel.

The owner must ensure that personnel work in a safety and hazard-conscious manner in compliance with the operating instructions.

The owner must ensure that product is only operated when in proper working order and that all relevant safety requirements and regulations are complied with.

The DRC-MP radio receiver must be taken out of service immediately if functional defects or irregularities are detected.

In the event of a stoppage (e.g. if defects regarding safe and reliable operation are detected, in emergency situations, in the event of operating malfunctions, for maintenance purposes, if damage is detected or after finishing work), the operator/experienced technician must carry out all prescribed safety measures or observe that they are automatically carried out.

During maintenance work the appropriate main switches must be switched off.

During operation or when the main switch is not switched off, electrical components inside enclosures, motors, switchgear cabinets, terminal boxes, etc., carry dangerous voltages. This voltage may cause fatal injuries.

Personal protective clothing must be worn as necessary or as required by regulations. Personnel must not wear loose clothing, jewellery including rings or long hair loose. Injury may occur, for example, by being caught or drawn into the mechanism.

All safety and hazard warnings on the product, its access routes and mains connection switches must be preserved completely and in legible condition.

Modifications, additions to and conversions of the product which might impair safety in any way must not be carried out without the approval of Demag.

Safety devices must not be rendered inoperative.

Only genuine Demag spare parts may be used. Observe prescribed deadlines or those specified in the operating instructions for routine checks/inspections.

2.5 Safety instructions for installation and disassembly

- Installation and disassembly work may only be performed by experienced technicians.
- Installation and disassembly work must be co-ordinated by the person carrying out the work and the owner within the scope of their responsibility.
- The working and danger zone must be made safe.
- The installation must be isolated in accordance with the relevant electrical regulations.
- Customer-specific regulations must be observed.
- Only appropriate, tested and calibrated tools may be used.

2.6 Safety instructions when first putting the unit into service after completing installation

- The working and/or danger zone must be made safe.
- First check that the voltage and frequency specified on the type plate match the control voltage of the system/machine.
- The commands for controlling the motion drives are disabled in the DRC-MP radio receiver until a transmitter has been clearly assigned and specified by means of the relevant initialisation dialogues and the crane ID. See transmitter operating instructions (DRC-10 or DRC-J).
- In the course of putting the product into service, it may be necessary to render safety devices or features inoperative when carrying out adjustments or function checks.
- When putting the machine into service, it may be necessary to perform work in the danger zone, therefore, it must be ensured that only appropriately trained personnel are employed for this work.

3 General description

3.1 Transmitter/receiver interface

The DRC-MP radio receiver can either be used with a DRC-10 hand-held transmitter or with a DRC-J joystick control system.

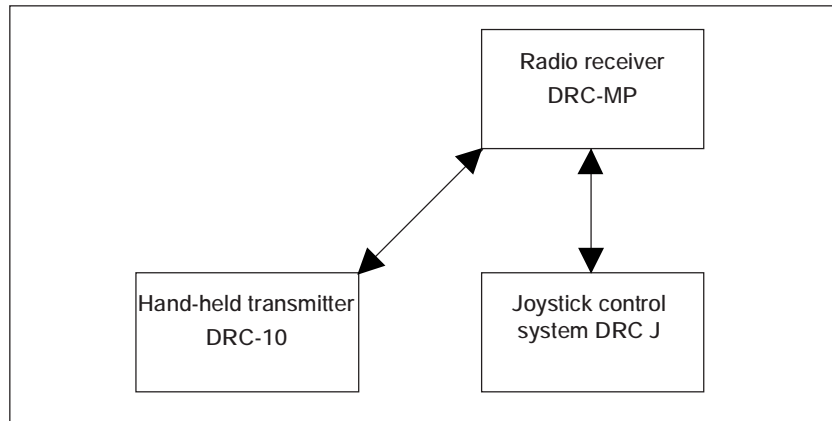

Radio remote control systems of the DRC range are exclusively intended for single-transmitter operation; i.e. there is always a clear assignment between a specific transmitter and its corresponding radio receiver.

3.2 Transmission method

The so-called ISM band (433 MHz) is used for transmitting the radio signals between transmitter and receiver. Within the ISM band 30 frequencies are used alternately in a defined sequence (so-called frequency hopping). A random-check generator determines the sequence of the frequencies when radio transmission is started. In order to increase transmission reliability, the information is transmitted several times. This method in connection with frequency hopping provides for a very high immunity to interference.

Frequency hopping is used for the first time with Demag DRC radio control system types D1-FH and D2. In the case of the D1 type, the frequency of the radio signal is not changed during a transmission cycle.

A decisive advantage of the frequency hopping transmission is that existing information contents are transmitted on several physical channels. This redundant radio transmission 1) provides for an exceptionally high insensitivity of radio transmission against other transmitters or electromagnetic interference.

1) Certain information contents are transmitted on up to 5 different frequencies. Only if (theoretically) all frequencies used were occupied or disturbed by other radio systems, communication would be interrupted.

3.2.1 Downwards compatibility of DRC-10 D2 transmitters

For combining DRC-10 D2 transmitters with D1 type receivers
 DRC-DR, part no. 719 441 45
 DRC-MP, part no. 773 432 44
 these transmitters must be programmed for operation at a fixed frequency (chapter “Programming parameters of the DRC-10 handheld transmitter”, section 1.6).
 The table below shows an overview of the possible combinations

3.2.2 Compatibility D1, D1 FH and D2

Transmitter	Type	Product Part no.	Receiver				
			D1 DRC-MP 773 432 44	D1 DRC-DR 719 441 45	D1 FH DRC-Mp 773 584 44	D1 FH DRC-DR 719 436 45	D2 DRC-DR 719 439 45
Transmitter	D1	DRC-10 773 431 44	OK	OK	not compatible	not compatible	not compatible
	D1	DRC-J 773 460 44	OK	OK	not compatible	not compatible	not compatible
	D1 FH	DRC-10 773 581 44	Fixed frequency	Fixed frequency	OK	OK	OK
	D1 FH	DRC-J 773 583 44	Fixed frequency	Fixed frequency	OK	OK	OK
	D2	DRC-10 773 591 44	Fixed frequency	Fixed frequency	OK	OK	OK

Explanation:

- D1 without frequency hopping
- D1 FH with frequency hopping
- D2 with frequency hopping and, if required, with extended functions

3.2.3 Frequency hopping feature

Transmitters and receiver with frequency hopping can be identified by the part no. on the rating plate.
 The different representation can be seen in the OFF mode (lock symbol) or in the STOP mode.

Transmitter without frequency hopping

Transmitter with frequency hopping

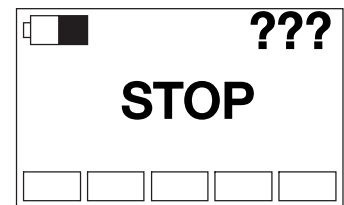
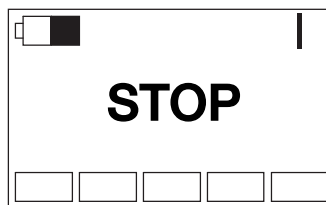
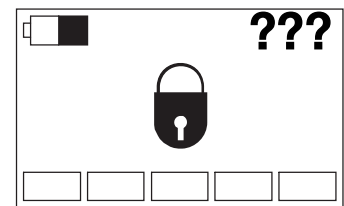
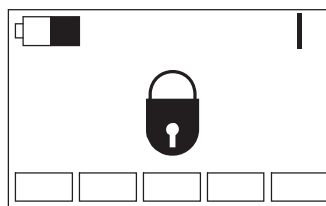

42747544.eps

4.1	DRC-MP scope of delivery	DRC-MP D1 FH radio receiver	Part no.: 773 584 44
4.2	Available radio transmitters	DRC-10 D2 hand-held transmitter DRC-J D1 FH joystick transmitter	773 591 44 773 583 44
4.3	Accessories for crane identification	3 Coding labels Carrier foil, black 3 Coding labels 7 segments (yellow) 1 Travel direction foil cross travel 1 Travel direction foil long travel	895 639 44 895 640 44 895 635 44 895 637 44
4.4	Cable set	Pre-fabricated 42-pole connection cable with PCB connector Cable length 2,4 m	773 429 44
4.5	Offset aerial	Accessories for fitting the offset aerial of the DRC-MP receiver Length of the aerial cable approx. 5m	773 586 44

Note:

In conjunction with the specified radio transmitters, the DRC-MP radio receiver complies with the relevant European directives and fulfils the requirements of the standards for cranes and hoists: EN 13557; EN 60204-32. The stop function fulfils safety category 3 to EN 954-1.

All components are designed for operation in industrial environments.

The requirements of the EC EMC directive are complied with in terms of the limit values for industrial environments.

In the Federal Republic of Germany, the BGV D6 and ZH1/547 regulations must be complied with for operation of a crane with radio-remote control.

To comply with the EMC requirements, the following points must be considered for integration into overall systems:

- Integration of electronic components to meet EMC requirements
- Use of prescribed or approved cables, screened cables, if required.
- Adherence to minimum distances for the application of cables and wiring with different potentials.

5 Putting the DRC-MP radio receiver into operation for the first time

5.1 Assembly and connection of the radio receiver

Fitting the radio receiver:

Bolt radio receiver housing to location where the receiver is to be mounted (switchgear cabinet, wall, etc.).

Connect the receiver to the installation to be controlled by means of the connected multi-pole connection cable.

Power supply to the radio receiver is via a connection cable (control voltage).

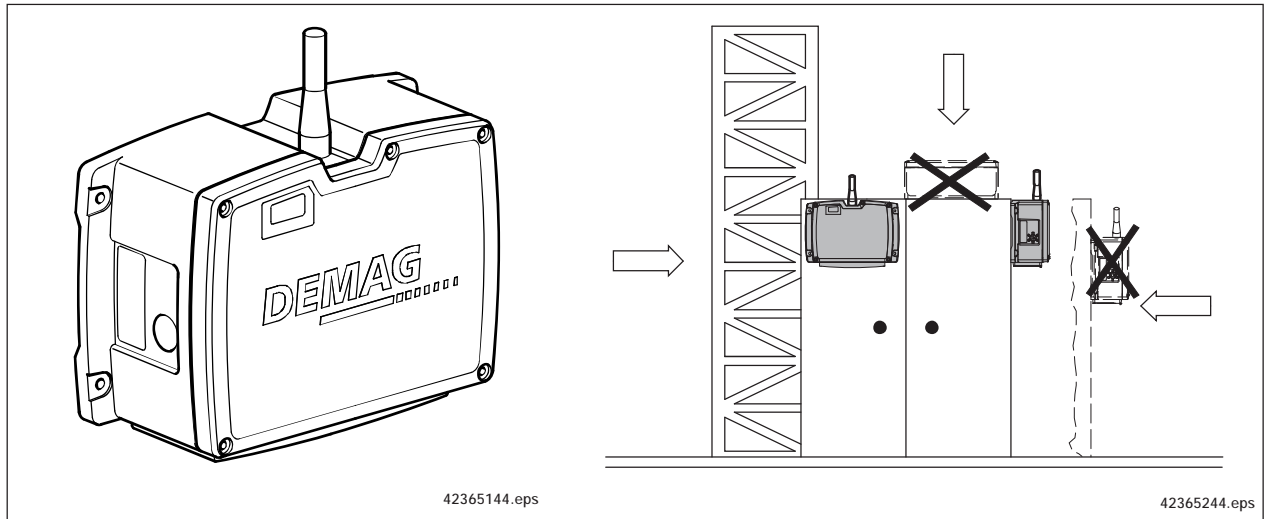

- Observe operating voltage of the radio receiver.
- Mount the radio receiver only in an upright position (cable out downwards).
- Do not fit radio receiver inside switchgear cabinets or in recesses.

All contacts/potentials are provided acc. to connection diagram section 5.4 via one multi-pole cable that must be connected.

The DRC-MP radio receiver must be connected to the control system in accordance with the circuit diagram of the supplier of the installation/machine or equipment.

The block wiring diagram in chapter 6 shows the example of an overhead travelling crane control system with connected DRC-MP radio receiver.

The DRC-MP radio receiver is supplied without connection cable as standard.

For connecting the DRC-MP radio receiver, a cable of type HYSLY-JZ with a conductor cross section of 0,75 mm² must be used. The connection cable must be rated in accordance with the circuit diagram.

If required, a pre-fabricated 42-pole connection cable may be ordered from Demag. Part no. 773 429 44

This connection cable is already provided with the appropriate connectors that make easy connection to the DRC-MP radio receiver possible.

Ensure that the installation/machine is at zero voltage according to the regulations and is secured against accidental restoration of the power supply for connection of the DRC-MP radio receiver.

When the control voltage has been switched on, the radio control system can be put into operation in accordance with the operating instructions of the transmitter used (DRC-10 or DRC-J).

For the first function test, we recommend that the main current supply to the drive motors be switched off.

When delivered, the DRC-MP radio receiver has crane identification "NOID". All crane movements are blocked. This block is removed when the unit is put into operation by assignment of a valid crane identification to the receiver in accordance with the operating instructions of the relevant transmitter (DRC-10 or DRC-J).

When fitting the receiver, make sure that the aerial is free to the extent possible (see figure in section 5.1).

Any shadows, in particular those caused by metallic parts in the direct vicinity of the aerial, have a negative effect on the max. possible range as well as on the stability of the radio connection between transmitter and receiver.

A “free view to all sides” from the point of view of the receiver aerial on the working range of the assigned transmitter is optimal.

If the mounting location of the receiver does not permit optimal placement of the aerial, we recommend that an aerial offset from the receiver be used.

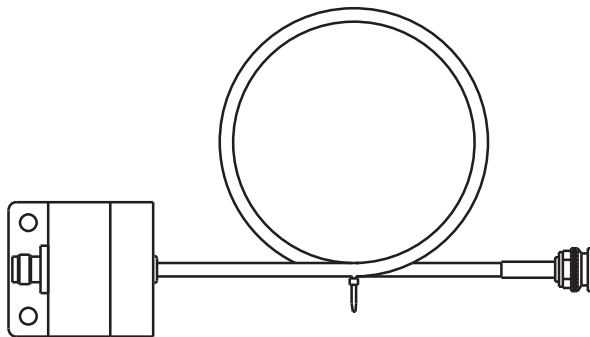

42736144.eps

Accessories for fitting the external aerial of the DRC-MP receiver (part no. 773 586 44), consisting of:

Coaxial aerial cable

- with fitted connector, prepared for connection to the DRC-MP receiver.
- with connected aerial base for accommodating the aerial of the DRC-MP receiver
(length of aerial cable approx. 5 m)

5.2 Assignment of terminals and functions

The following illustration shows the positions of the connection terminals inside the DRC-MP radio receiver and the equipment of the PCB.

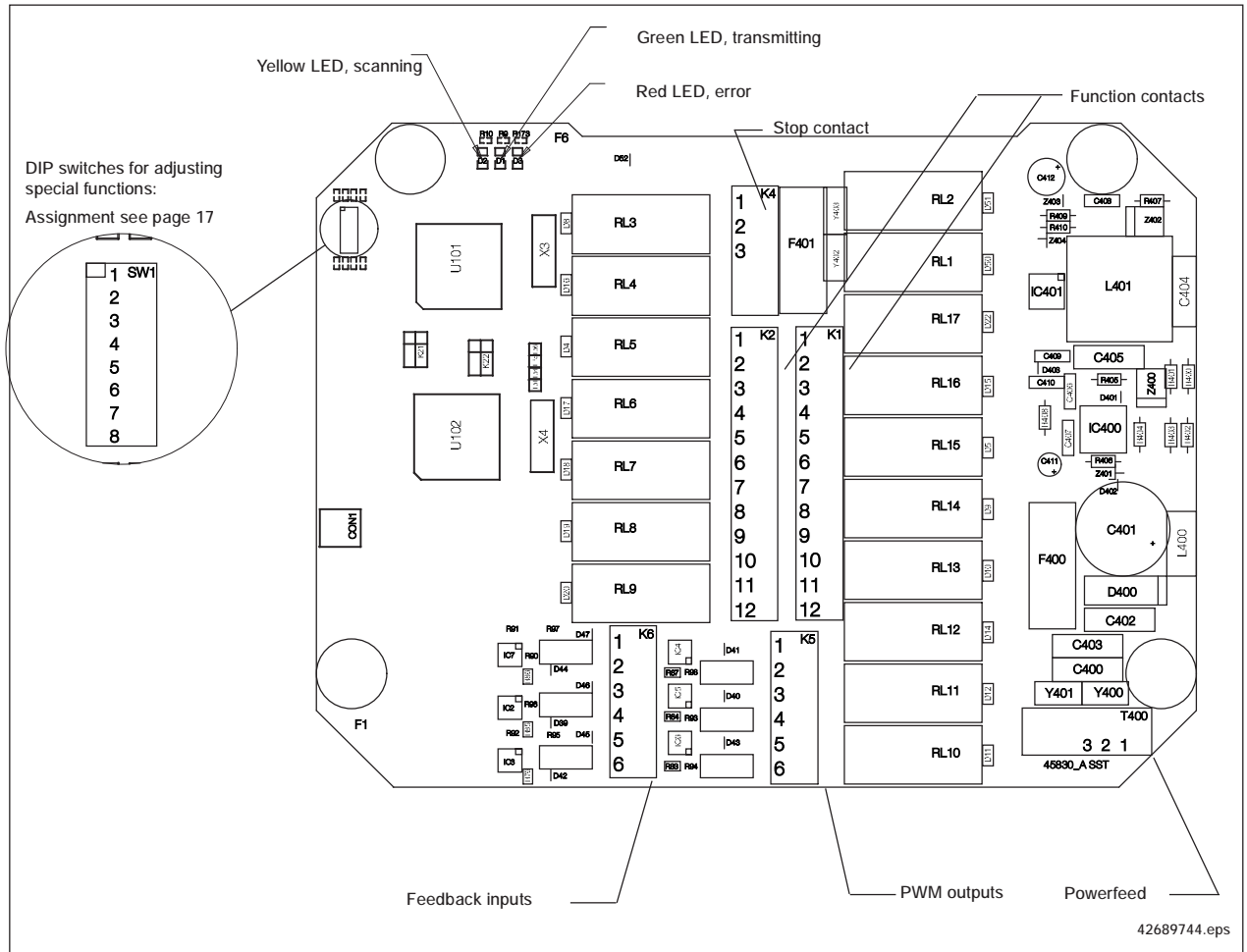

5.3 Explanation of radio receiver LED's

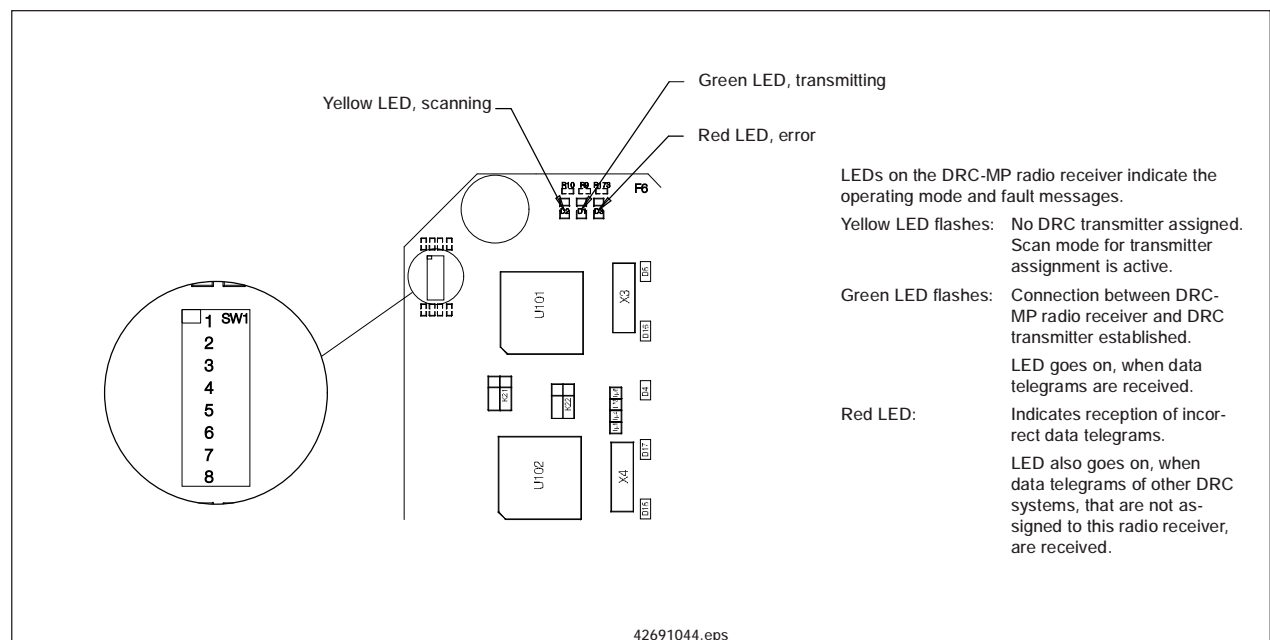

5.4 Radio receiver connection diagram (Connection example with a 42-pole connection cable)

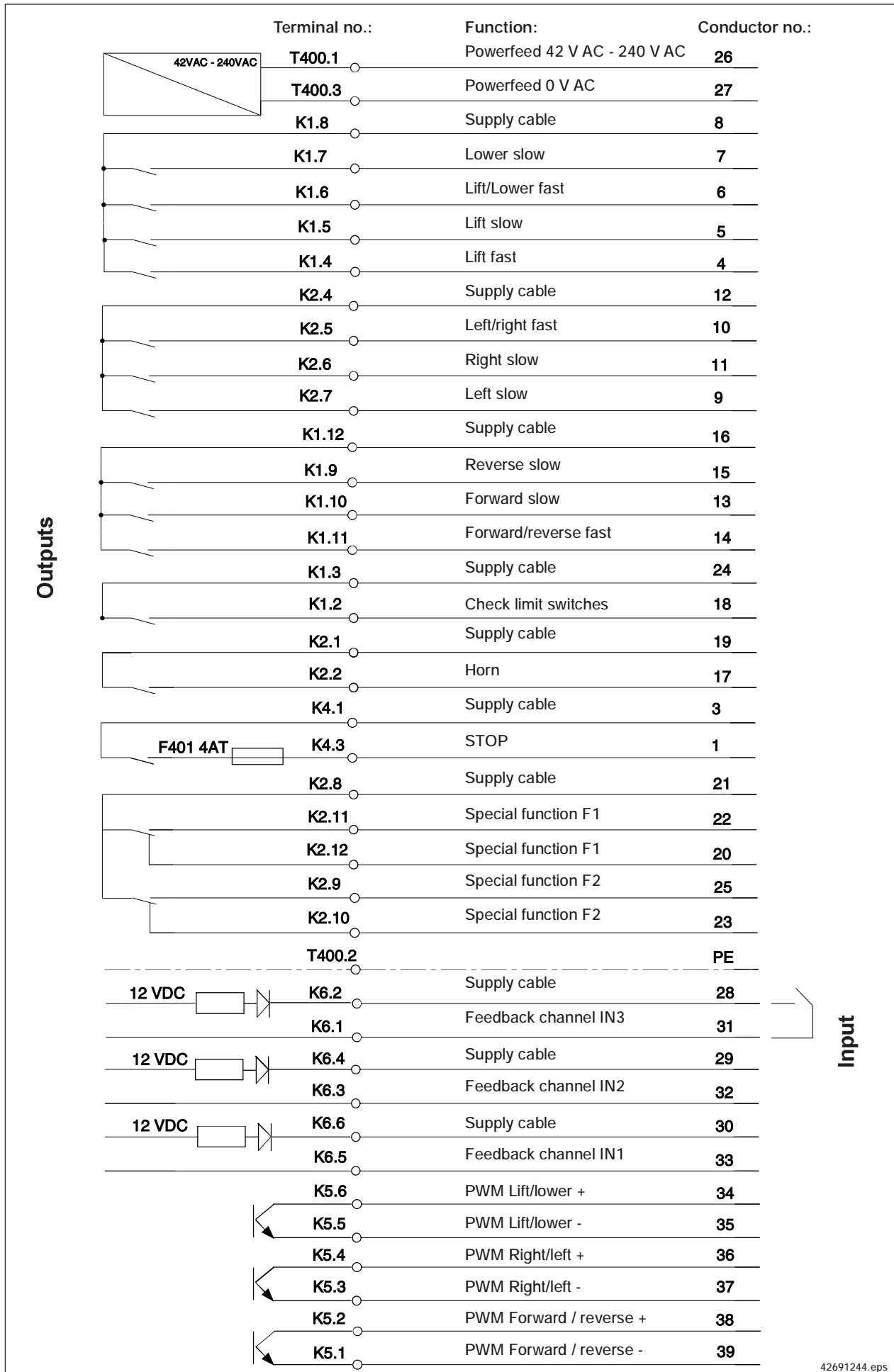

5.5 Activating and adjusting special functions

DRC-MP radio receivers are provided with adjustable special functions to adapt the sequence of switching processes for the control of the drive motors to the application and to feedback information on operating conditions of the installation to the transmitter. The following functions can be set:

- 'BE function' brake application control for travel motors, see section 5.5.1.
- 'Feedback channel information' display of feedback channels, see section 5.5.2.
- 'SDGM function' start-up control for pole-changing hoist motors, see section 5.5.3.
- 'LIFT-FAST relay' selection of the contactor control variant for pole-changing hoist motors, see section 5.5.4.

When delivered, the DRC-MP radio receiver has the following settings:

- Brake application control is switched off.
- Display of feedback channel information un-encoded, i.e. I or I + II or II and



- Start-up control for pole-changing hoist motors is switched off.
- Selection of the contactor control variant with joint quick contactor (3-contactor variant)

5.5.1 BE function general

When pole-changing squirrel cage rotor travel motors are switched down from fast to slow speed, unwanted loads on mechanical components and load sway result. It is therefore recommended to use the integral BE (brake application) function in conjunction with the DRC-MP radio remote control system. This ensures that mechanical braking is started when the fast travel speed has been switched off. Only after expiration of an adjustable delay time can the slow travel speed be switched on again. Only after expiration of an adjustable delay time can the slow travel speed be switched on again.

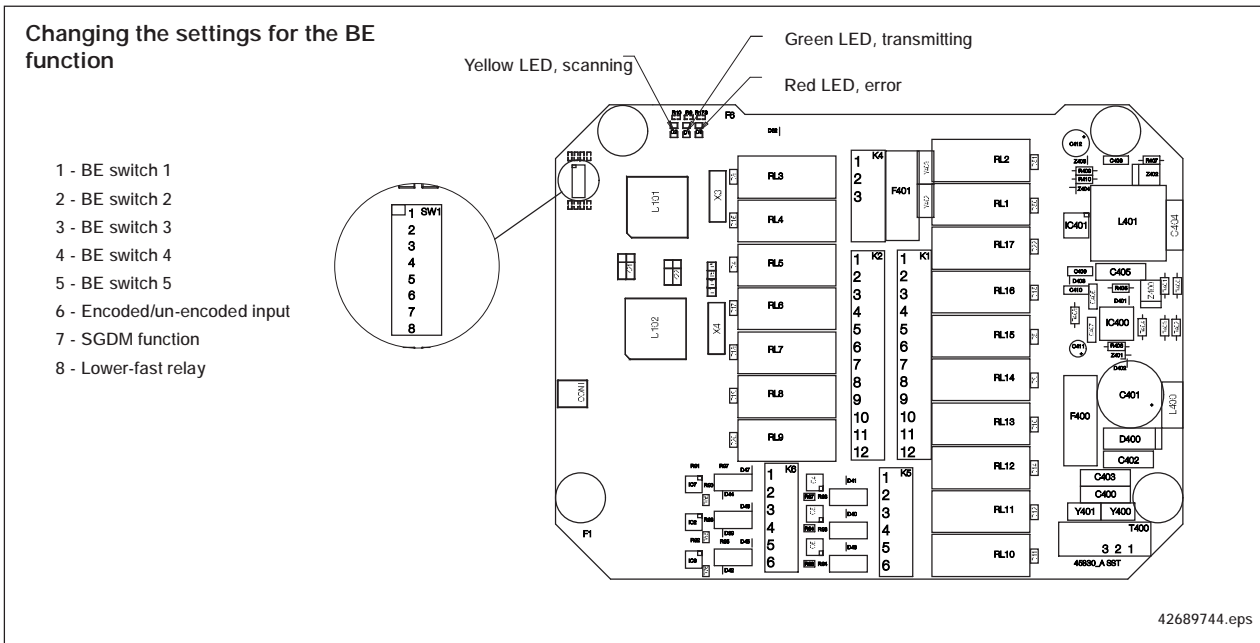

Description of BE function

If required, this function is activated for the travel axes by setting the DIP switches on the board of the radio receiver (Default: switches 1 - 5 OFF).

After fast speed (V2) signal has been switched off, the fast and the slow speed (V1) contacts open and thus generate mechanical braking. Upon expiration of the time interval set and if the control signal (slow) is available, the slow speed is switched on again for the drive unit.

If V2 is switched on again during the braking time, the contacts for V1 and V2 close without delay, i.e. the fast speed is switched on again.

Time intervals which can be set: 1 - 2 - 2,5 - 3 seconds and de-activation (by means of a switch in the receiver).

Select time interval so that upon expiration of this braking time the travel drive has been braked from V2 to V1.

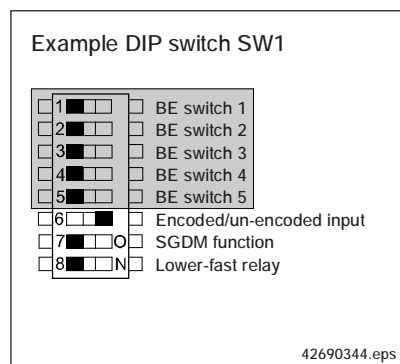

Changes of the DIP switch settings only become effective when the receiver is switched on again.

For example of setting no. 0, see table on page 19

No.	Switch 1	Switch 2	Switch 3	Switch 4	Switch 5	Crane in [sec.]	Trolley in [sec.]
0	OFF	OFF	OFF	OFF	OFF	0	0
1	OFF	OFF	OFF	OFF	ON	0	1
2	OFF	OFF	OFF	ON	OFF	0	2
3	OFF	OFF	OFF	ON	ON	0	2,5
4	OFF	OFF	ON	OFF	OFF	0	3
5	OFF	OFF	ON	OFF	ON	1	0
6	OFF	OFF	ON	ON	OFF	1	1
7	OFF	OFF	ON	ON	ON	1	2
8	OFF	ON	OFF	OFF	OFF	1	2,5
9	OFF	ON	OFF	OFF	ON	1	3
10	OFF	ON	OFF	ON	OFF	2	0
11	OFF	ON	OFF	ON	ON	2	1
12	OFF	ON	ON	OFF	OFF	2	2
13	OFF	ON	ON	OFF	ON	2	2,5
14	OFF	ON	ON	ON	OFF	2	3
15	OFF	ON	ON	ON	ON	2,5	0
16	ON	OFF	OFF	OFF	OFF	2,5	1
17	ON	OFF	OFF	OFF	ON	2,5	2
18	ON	OFF	OFF	ON	OFF	2,5	2,5
19	ON	OFF	OFF	ON	ON	2,5	3
20	ON	OFF	ON	OFF	OFF	3	0
21	ON	OFF	ON	OFF	ON	3	1
22	ON	OFF	ON	ON	OFF	3	2
23	ON	OFF	ON	ON	ON	3	2,5
24	ON	ON	OFF	OFF	OFF	3	3

Changes of the DIP switch settings only become effective when the receiver is switched on again.

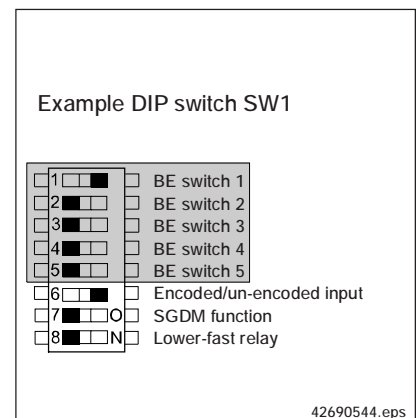
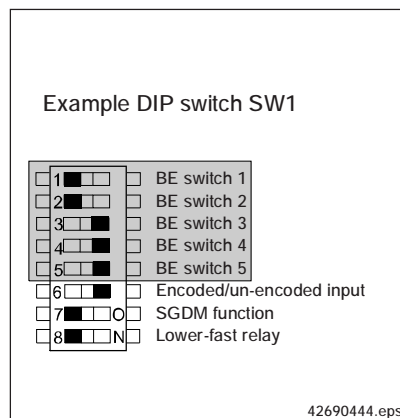

For example of setting no. 7, see table

For example of setting no. 16, see table

5.5.2 Feedback channel information

DRC-10 hand-held transmitters and DRC-J joystick control systems are provided with an integrated display, which can also be used for the display of feedback channel information.

To implement this function, the DRC-10/DRC-J transmitter and the DRC-MP radio receiver operate as bi-directional radio systems.

This means, that the DRC-MP radio receiver can also send data/information to a DRC-10/DRC-J transmitter.

For this purpose, the DRC-MP is provided with three feedback channels on the radio receiver side that are activated by means of an NO contact.

See connection diagram, section 5.4.

Two different display modes can be activated via DIP switch 6 ('encoded – un-encoded display').

Setting for encoded
(DIP switch 6 on ON)

In this display mode, the three feedback channels are evaluated as a binary code and displayed as number information on the display of the transmitter.

Displayed number

(Display transmitter)	IN1	IN2	IN3
0000	0	0	0
0001	0	0	1
0002	0	1	0
0003	0	1	1
0004	1	0	0
0005	1	0	1
0006	1	1	0
0007	1	1	1

0 = open

1 = closed

Setting for un-encoded
(DIP switch 6 on OFF,
default setting)

In this display mode, the status is displayed with the feedback contacts for control of a crane with two trolleys:

Digital Input	Display	Symbol
IN1 closed	'Trolley 1 selected' symbol	I
IN2 closed	'Trolley 2 selected' symbol	II
IN1 and IN2 closed	'Trolley 1 + 2 selected' symbol	I + II
IN3 closed	Display of the "warning" symbol	

The meaning of the warning symbol must be defined in line with the application.

5.5.3 SGDM function

The SGDM function has been developed for high-performance, pole-changing hoist motors to avoid overloads caused by frequent start-up and braking cycles.

1. Starting

This function ensures that the motor is always started by means of the winding with the higher number of poles. As a consequence, switchgear and wiring can be of a less expensive design. It is important that, when switching over to the winding with the lower number of poles, this is switched on before the winding with the higher number of poles is switched off.

2. Braking

An important factor for the service life of brake linings is the speed at which braking begins. The speed ratio is used as a quadratic value for the calculation of the service life of the brakes. For pole-changing hoist motors with a speed ratio of 1 : 6 this means that, when braking at the lower speed, the service life of the brake linings is 36 times longer than that obtained when braking at the higher speed. The SGDM function ensures that the hoist motor is always braked electrically when it is switched from the main hoist speed to the creep hoist speed. This can be taken into account when calculating the brakes, above all for larger hoist unit motors.

3. Functional sequence

3.1 Starting

When the appropriate button on the control pendant is pressed to the first step, the direction of movement (creep lifting or creep lowering) is switched on immediately. If the button is pressed directly to the second step, the creep lifting speed is switched on first and then, after approx. 0,4 seconds, the main lifting speed. To prevent flick-switching during operation at main lifting speed, the SGDM stops the hoist being switched on again for 2,5 seconds after the main lifting speed is switched off. The delay times are preset at fixed values.

3.2 Braking

When switching back from the second step directly to 0, the creep lifting speed is automatically switched on for approx. 0,5 seconds. This delay time, too, is preset as a fixed value.

Changing the settings for the SGDM function

If required, this function is activated for the lifting axis by setting the DIP switches (Default:OFF).

Function	Switch 7
SGDM active	ON
SGDM not active	OFF

Changes of the DIP switch settings only become effective when the receiver is switched on again.

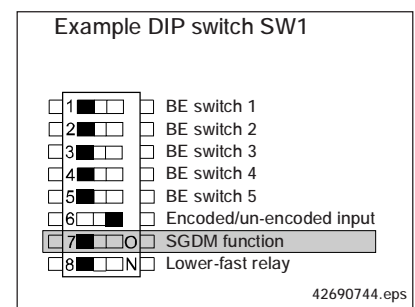

5.5.4 LIFT-FAST relay

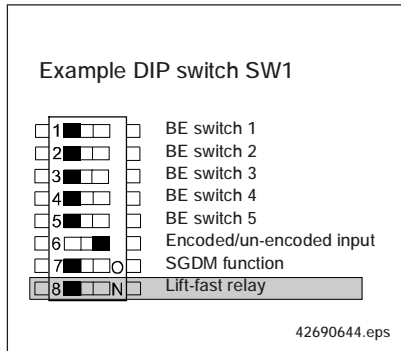

In the default setting, the contact of "LIFT-FAST" performs the "FAST" function (for LIFTING and LOWERING). The contact of "LIFT-FAST" always remains switched off. The "LIFT-FAST" contact is activated by switching over the DIP switch (see below). Changes of the DIP switch settings only become effective when the receiver is switched on again.

LIFT-FAST relay	Switch 8	
Active	ON	x 4 relays
Not active	OFF	x 3 relays

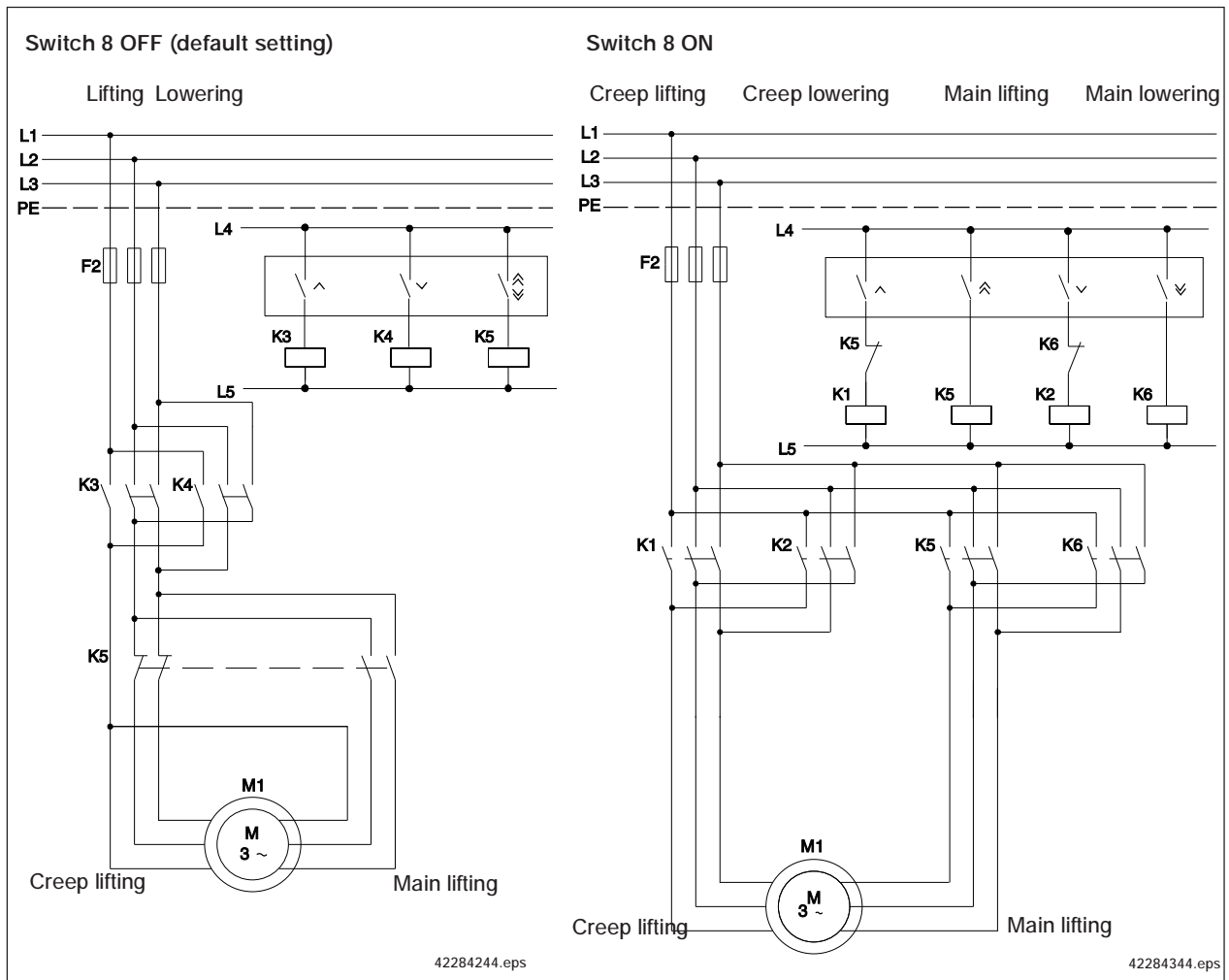

Anti-plugging protection

When the lifting/lowering or lowering/lifting direction is changed, the corresponding changes on the output relays on the receiver side are made with a fixed delay time of 250 ms.

This delay is also effective when the SGDM functions is not activated.

For controlling pole-changing hoist motors with contactor control, two basic variants are used:

One variant with 3 coils and a joint contactor for the fast speed for lifting and lowering (left figure) and a variant with 4 contactors so that for lifting and lowering, two separate contactors for LIFT-FAST and LOWER-FAST are controlled (right figure).

5.6 Function check after installation

A general function check of the receiver is possible by means of the light diodes in the window of the cover, see also section 5.3.

- The yellow LED flashes, when the receiver is supplied with current and no hand-held transmitter has been assigned yet. In addition, the red LED flashes, when radio telegrams of transmitters that have not been assigned are received.
- The green LED flashes, when the receiver is supplied with current and radio telegrams of an assigned hand-held transmitter are received. When this hand-held transmitter is in Stop mode, the flashing sequence is approx. 5/sec. When the hand-held transmitter is in Run mode, the flashing sequence changes to rapid 10/sec.

Further function checks are only possible by operation of a suitable radio transmitter (DRC 10 or DRC J). Proceed in accordance with the operating instructions of the radio transmitter and the crane installation.

A qualified electrician can check the status of the output contacts by means of suitable measuring equipment based on the connection diagram, section 5.4. In the receiver housing, activation of the output relays is indicated by the associated LED. These checks may only be carried out by a qualified electrician, if measures to protect against contact with live parts have been taken.

6 Block wiring diagram (Example with a 42-pole connection cable)

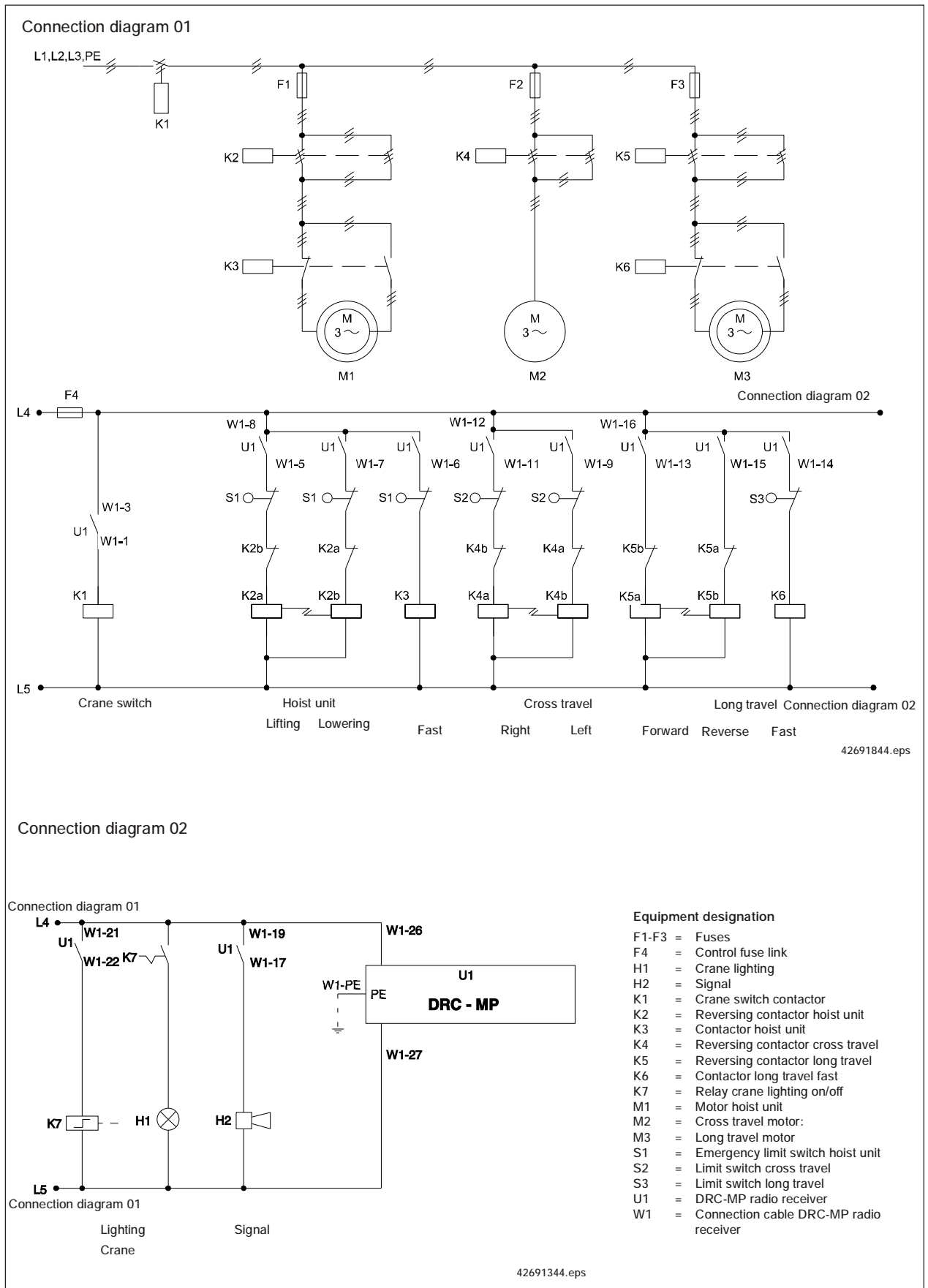

7 Technical data

DRC-MP receiver

Output relay	250 V, 8 A/AC 11
PWM outputs	3 off Open collector outputs Basic frequency 1 kHz Pulse width 10 %: V_{min} Pulse width 90 %: V_{max} U_{EC} max.: 30 V I_A max.: 20 mA
LED indicators for	Scan mode (yellow LED) Communication OK (green LED) Error (red LED) and LEDs for indicating the status of the output relays
Type of enclosure	IP 65
Ambient temperature	- 20 to + 70° C
Weight of radio receiver	1.5 kg
Supply voltage	42 - 240 V AC, 50/60 Hz \pm 10 %
Power consumption	12 VA
Cable type to be used	HYSLY-JZ n x 0,75 mm ²
4 fitting holes with	dia. 6 mm
Cable union	M 24 x 1.5

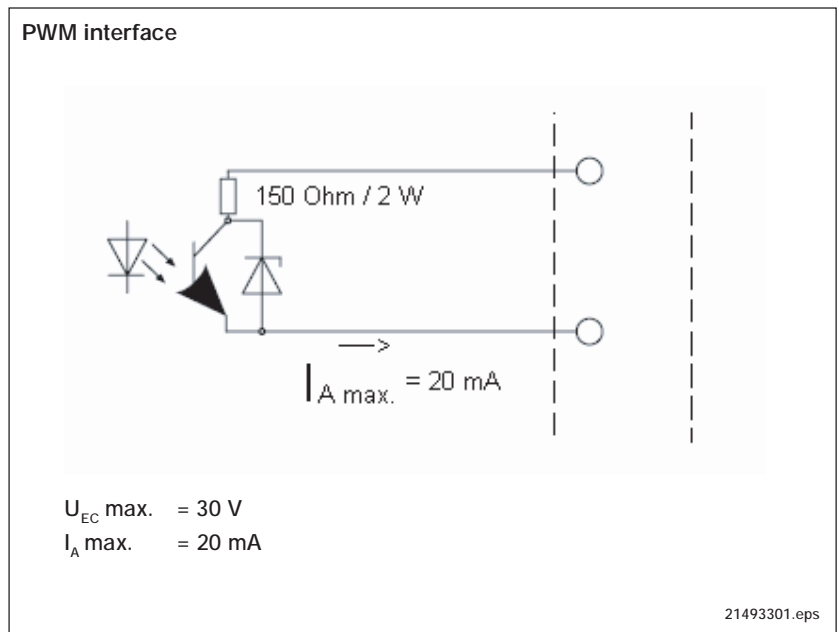

8 Dimensions

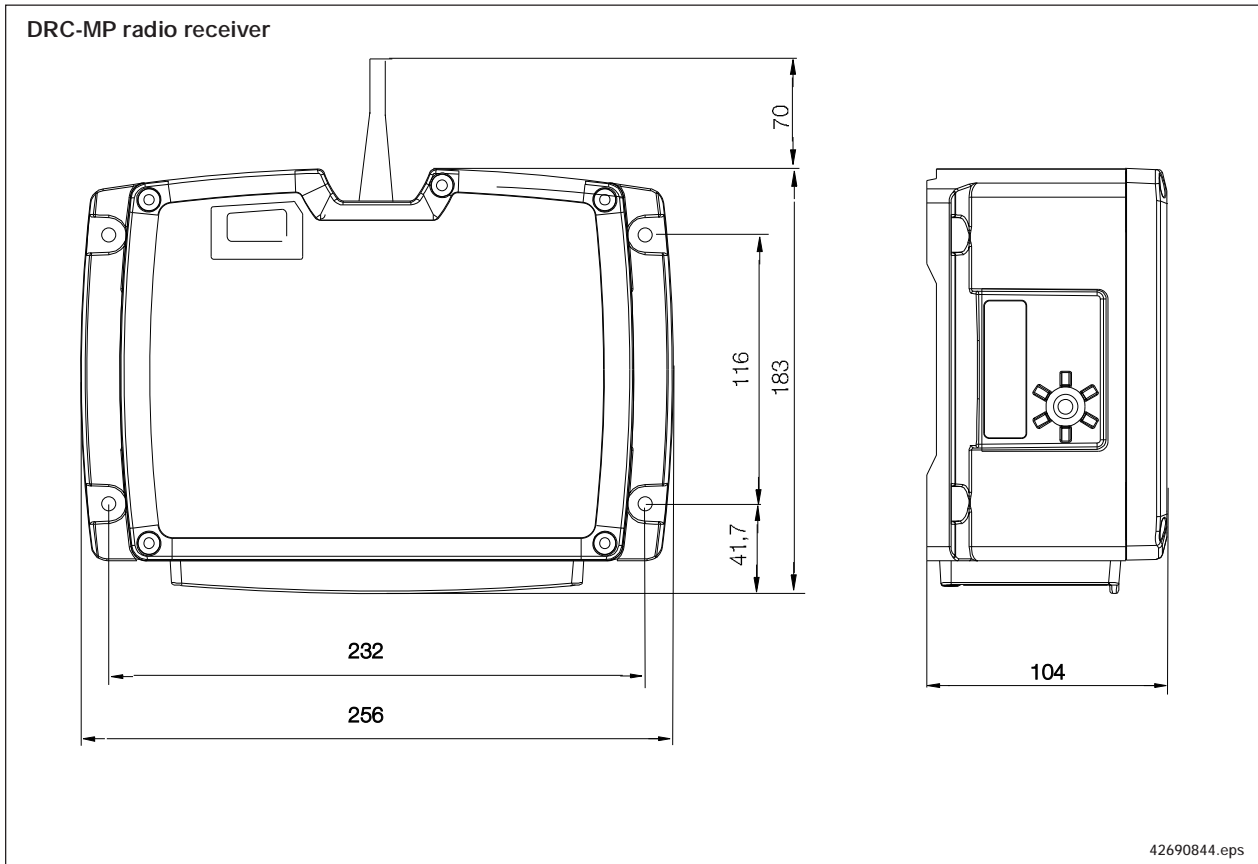

9 International postal registration

In the following countries, transmitters and radio receivers of the DRC-MP range in the standard delivery form can be operated without any registration or operating fee:

Countries	Frequency range
Australia	433-MHz ISM band
Belgium	433-MHz ISM band
Denmark	433-MHz ISM band
UK	433-MHz ISM band
Estonia	433-MHz ISM band
Finland	433-MHz ISM band
France	433-MHz ISM band
Greece	433-MHz ISM band
Holland	433-MHz ISM band
Ireland	433-MHz ISM band
Iceland	433-MHz ISM band
Italy	433-MHz ISM band
Croatia	433-MHz ISM band
Norway	433-MHz ISM band
New Zealand	433-MHz ISM band
Poland	433-MHz ISM band
Portugal	433-MHz ISM band
Switzerland	433-MHz ISM band
Slovakia	433-MHz ISM band
Slovenia	433-MHz ISM band
Spain	433-MHz ISM band
Sweden	433-MHz ISM band
Czech Republic	433-MHz ISM band
Germany	433-MHz ISM band
Hungary	433-MHz ISM band
Austria	433-MHz ISM band

On request, the relevant approvals and/or certificates are available.

Operation in the following countries requires special approvals (e.g. import license): Russia, Singapore, South Africa, Korea

Please contact the manufacturer, if use of the product is planned in one of these countries .

	EC conformity declaration Demag radio control system in accordance with EC directive 89/336/EEC, Appendix I, 73/23/EEC, Appendix III and 99/5/EC #	1 page(s) Page 1
		Ident. no. 205 331 44
		Issue 0107 EN

Hereby we,



Demag Cranes & Components GmbH

declare that the product

**Demag radio control system RC-10, RC-J,
DRC-10, DRC-J,
DRC-MP, DRC-DR, DRC-DC 1) #**

of serial design is in conformity with the provisions of following relevant regulations:

EC EMC directive amended by	89/336/EEC 92/31/EEC and 93/68/EEC	
EC Low voltage Directive	2006/95/EC	
EC radio and TTE directive	99/ 5/EG	#

Applied harmonised standards:

EN 954 -1	Safety related parts of control systems
EN 13557	Control elements and control positions
EN 50178	Electronic equipment for use in electrical power installations and their assembly into electrical power installations
EN 60204-32	Electrical equipment, requirements for hoists
EN 60529	Types of enclosure (IP code)
EN 61000-6-2	Electromagnetic compatibility – Immunity for industrial environments
EN 61000-6-4	Electromagnetic compatibility – Emission standard for industrial environments
EN 300220-3	Electromagnetic compatibility and radio spectrum matters (ERM); Short Range Devices (SRD)

Wetter, 16 January 2007

Place and date of issue



ppa. Gersemsky
Technik Handling Technology



ppa. Hoffmann
BU Handling Technology

1) 1) Application of CE symbol in accordance with EC Low Voltage Directive 2006/95/EC:
RC-10 1998; RC-J 2000; DRC-10 2004; DRC-J 2004; DRC MP 2005; DRC-DR 2005; DRC-DC 2006.

Printed in Germany

# = Modifications compared to previous issue	Normung DCC	Class. no. 715 IS 975
--	-------------	--------------------------

Notices and Warnings

This device complies with part 15 of the FCC Rules and RSS-210 of IC Rules. Operation is subject to the following two conditions: (1) This device may not cause harmful interference, and (2) this device must accept any interference received, including interference that may cause undesired operation. Changes or modifications not expressly approved by Scanreco Industrietechnik AB will void the user's authority to operate the equipment.