

FCC/MELLON OCT 13 1998

REMOTE CONTROL SYSTEM

SCANRECO RC 400.

INSTRUCTION MANUAL.

FCC / USA

This device complies with part 15 of the FCC-rules. Operation is subject to the following two conditions :

(1) This device may not cause harmful interference, and (2) this device must accept any interference received , including interference that may cause undesired operation.

Warning : Changes or modifications to this unit not expressly approved by the party responsible for compliance could void the user's authority to operate the equipment.

CONTENTS.

1. **PREFACE.**

2. **GENERAL SYSTEM DESCRIPTION.**

3. **SAFETY REGULATIONS AND OPERATING
INSTRUCTIONS.**

4. **INSTALLATION INSTRUCTIONS.**

5. **FAULT FINDING.**

6. **SPARE PARTS.**

7. **OPTION : REGULATIONS AND AUTHORITIES,
TYPE APPROVAL CERTIFICATES.**

8. **PROGRAMMING PARAMETERS AND SETTINGS.**

9. **ACCESSORIES / OPTIONS.**

Design, equipment, technical data and specification are subject to change or improvement without prior notice. The text of this manual, or any part thereof, may not be reproduced or transmitted in any form or by any means, electronic or mechanical including photocopying, recording, storage in an information retrieval system, or otherwise, without the prior written permission of Scanreco AB, Sweden.

Chapters 6, 7, 8 and 9 are abbreviated versions.

1. PREFACE

This manual is intended as a complement to the crane / machine instruction book and covers the Scanreco RC 400 Remote Control System.

The Scanreco RC 400 offers the driver an extremely advanced remote control system with speed, precision and control and with maximum safety.

In order to ensure your safety and the safety of your crane / machine you should study and learn these instructions. This will enable you to more quickly familiarise yourself with your new remote control system and how best to utilise it.

For the crane driver :

Pause for a while and give yourself extra time to read chapters :

"Chapter 2. General system description" , "Chapter 3. Safety regulations and Operating instructions".

For the installer :

Pause for a while and give yourself extra time to read chapters :

"Chapter 4. Installation instructions " and "Inspection / Installation documents".

- **Remotely controlled cranes may only be operated by qualified personnel. The driver must be aware of the contents of chapter 3 "Safety regulations and Operating instructions" before operation is started ! Serious accidents can occur if these instructions are not followed !**
- **To protect the portable control unit from damage and also for safety reasons, the control unit must be kept in a locked cab.**
- **Follow the instructions given in the crane handbook regarding moving the crane from its parking position, the best arm positioning while loads are being handled and parking of the crane.**
- **Due to the unlimited variety of cranes, machines, objects, vehicles and equipment on which the remote control system (RC 400) are used, and the numerous standards which are frequently the subject of varying interpretation, it is impossible for Scanreco AB / Swedens, personnel to provide expert advice regarding the suitability of a given RC 400 remote control for a specific application.
It's the purchaser's responsibility to determine the suitability of any Scanreco RC 400 product for an intended application, and to insure that it is installed and guarded in accordance with all country, federal, state, local, and private safety and health regulation, codes, standards and Scanreco's recommendation (*This manual*).
If the Scanreco RC 400 will be used in a safety critical application, the customer -/ driver must undertake appropriate testing and evaluation to prevent injury to the ultimate user. Scanreco AB, Sweden does not take responce for any damage or injurie.**
- **Unauthorized tampering with Scanreco RC 400 automatically invalidates guarantee !**

2. GENERAL SYSTEM DESCRIPTION.

Contents :	Page :
• General schematic of the Scanreco RC 400	2.2
• General description of the remote control system	2.3
• The portable control unit	2.3
• Battery operation (<i>See also 2.11 - 2.12</i>)	2.4
• Manoeuvre levers	2.5
• Emergency stop panel	2.6
• Changing radio channels (Due to frequency blocking)	2.6
• Switch panel	2.6
• Micro - speed control	2.6
• ON/OFF functions	2.7
• Cable for cable control	2.7
• Opto-fibre cable	2.8
• Electronicbox	2.9
• Expansion cable (EX)	2.10
• Crane emergency stop box	2.10
• Battery pack	2.11
• Battery charger and battery charging	2.12
• Radio control	2.13
• Radio transmitter	2.14
• Radio receiver box	2.15
• Option : Duplex-communication with display to give current weight loading, moment etc.	2.16 - 2.19

General schematic of the RC 400 :

The Remote Control System is comprised of the following components:

- Control unit (for cable or radio control).
- Electronicbox.
- Crane emergency stop box.
- Expansion cable (EX).

- *Cable operation:* Control cable (3-core).

- *Radio operation:* Radio transmitter, Qty. 2. battery packs, battery charger and radio receiver box.

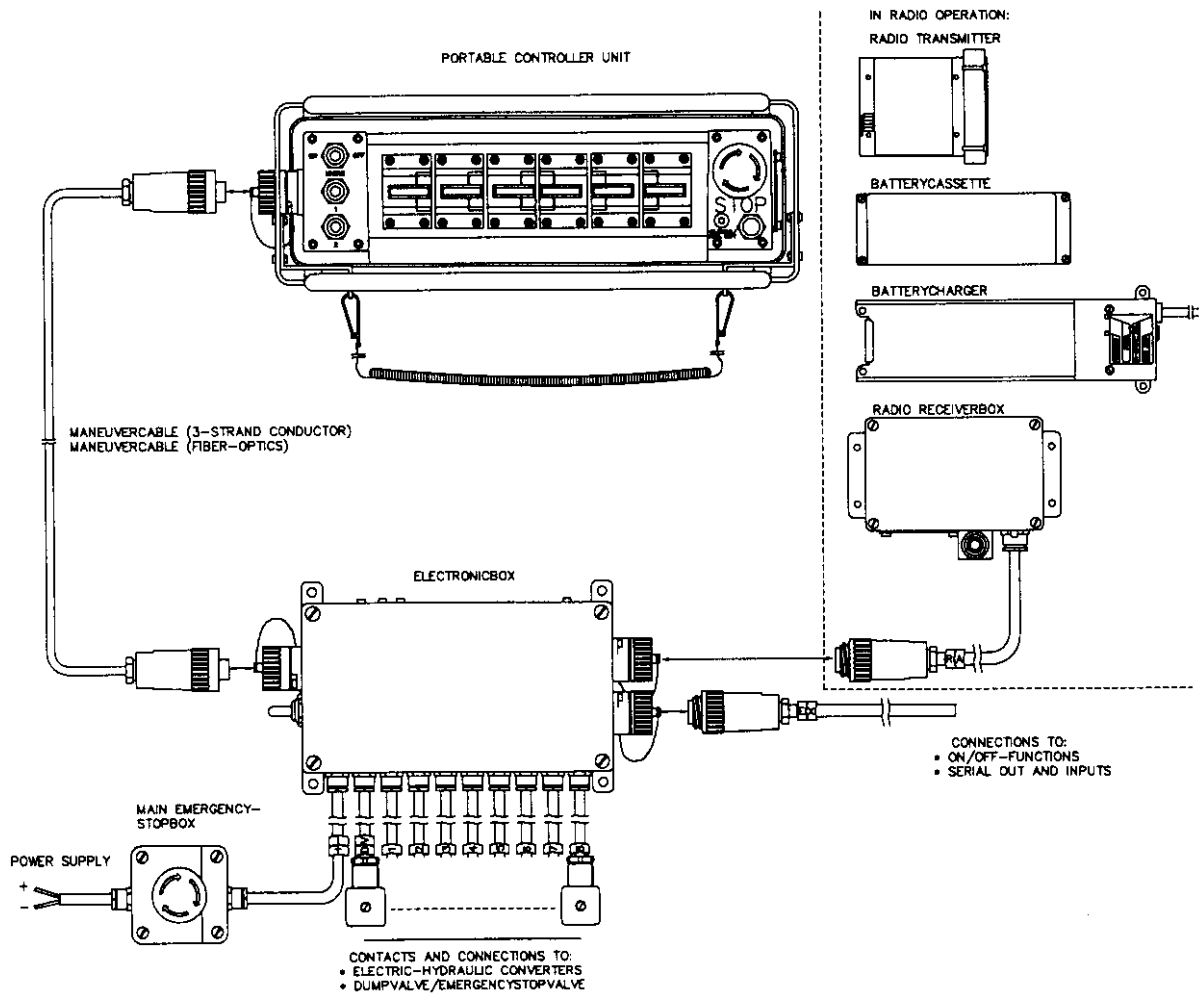

1. GENERAL DESCRIPTION OF THE REMOTE CONTROL SYSTEM.

The Scanreco RC 400 remote control system has been specially developed for hydraulically driven mobile cranes and machinery. The system is a digital remote control system based on an extremely advanced micro-processor technology. Years of exhaustive and demanding testing have shown that the remote control system can cope with the roughest of environments.

The remote control system is tested and approved for use in, amongst others, power stations, with a sky lift for personnel, close to work areas using blasting, on oil platforms, military establishments or other areas with explosive environments. The system is protected against electromagnetic and radio frequency radiation and can be installed onto all hydraulic valve types (voltage, current, pulse width, or protocol steered) found on the market.

In its basic form the remote control system is comprised of a portable control unit with manoeuvre levers for proportional control and switches for ON/OFF functions, an electronic-box with connection cable for driving proportional electro-hydraulic slide controllers.

Digitally coded control information (lever deflection and switch position) is sent from the control unit via electric cable, opto fibre cable or via radio to the electronicbox.

The control unit and electronicbox translate the magnitude and direction of the manoeuvre lever deflections and switch positions to corresponding valve function speed and direction and thus crane movement.

2. PORTABLE CONTROL UNIT (for cable, opto fibre cable, and radio operation).

General description of the portable control unit.

The portable control unit is impact and weather resistant and is light weight and compact. Controls are available for 3, 4, 5 or 6 manoeuvre functions. The manoeuvre levers are fully proportional and have spring return to the zero position, i.e. a "dead-man's-handle". The control unit has an emergency stop function which will immediately stop all movement. All manoeuvre levers are protected with a protective frame against unintentional activation and against mechanical damage. The control unit has multi-step micro-speed operation as standard enabling instantaneous temporary reduction of speed and it can also be equipped with a large number of switches for ON/OFF functions. A LED and sound signal are used to indicate such things as operating and battery status and for a simple and diagnostic fault finding. (See picture of control unit).

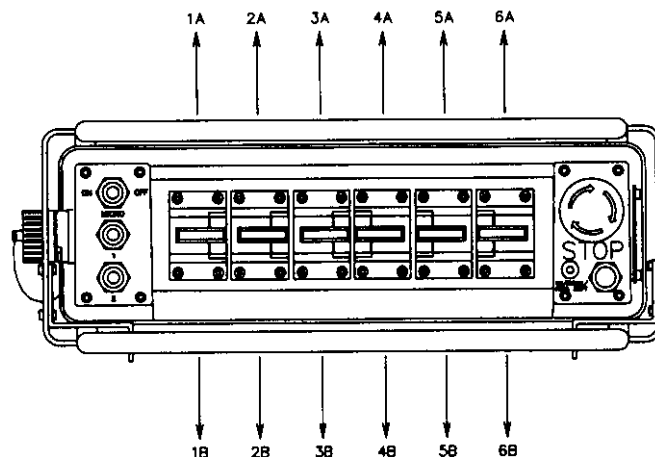

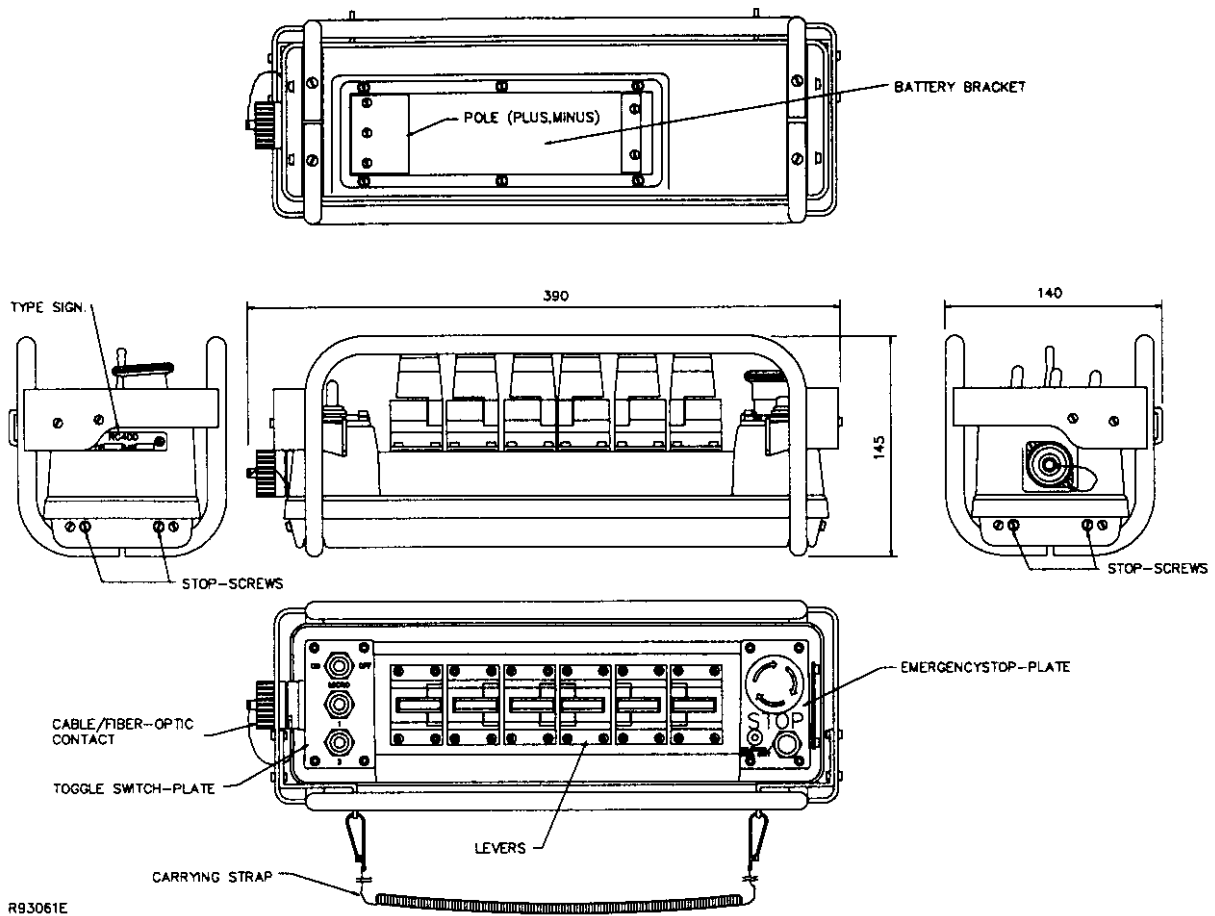

Portable control unit with battery operation (radio control or opto fibre cable).

A battery is located in the control unit for radio control and is very simple to change.

- The battery's effective operation time is about 8 hours on one charge.
- When the battery is approaching time for charging, the control unit beeps three (3) times as a warning and at the same time the LED starts to blink on the control unit.
- The battery must be used until the LED goes out, after which it can be changed. If the battery capacity is too LOW the control unit cannot be activated.
- The battery capacity and operational performance is reduced in extremely cold conditions. (The battery is automatically charged during operation by cable control).
- In order to reduce battery loading and for safety reasons, the control unit is turned off automatically, after the unit has been idle for more than approximately five (5) minutes.

A brief description is given now of the component parts of the control unit.

The control unit is comprised of manoeuvre levers for proportional control, switches for ON/OFF and function changing, micro-operation and emergency stop. (See separate headings below).

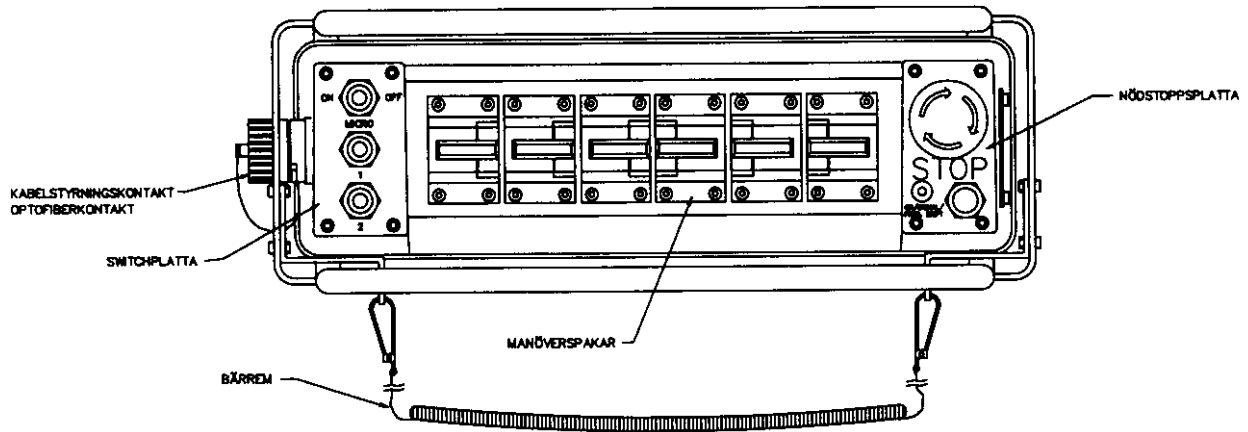

Manoeuvre levers.

The manoeuvre levers give fully variable proportional operation and are sprung loaded to return to zero position, i.e. "dead-man's-handle". When the manoeuvre levers are moved from zero position the respective hydraulic function starts to operate slowly and increases in speed as the lever is moved further from zero position and vice versa as the lever is moved back towards zero position. If any levers are not included for a particular installation, a cover plate can be mounted for the unused lever locations. (See also title " Micro-speed control ").

For safety reasons all manoeuvre levers must be in their zero/neutral positions for a start-up to be made. If any lever is not in its zero / neutral position during start-up, the control unit will blink and beep the same number of times as the number of the lever to indicate which manoeuvre lever is faulty. The control unit can be used but the faulty lever will be locked and disengaged. (For example if it beeps and blinks five (5) times, it is the 5th lever from the LEFT which is faulty or giving the problem signal).

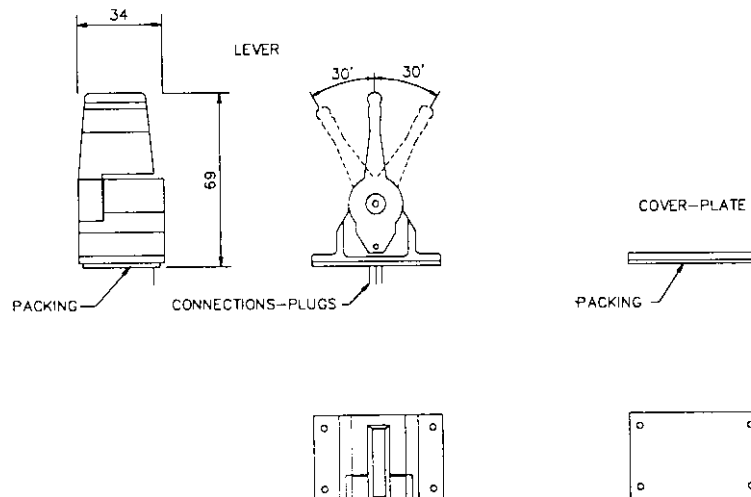

Emergency stop panel.

There is a red emergency stop switch (**STOP**) with a manual twist reset, a push button (**ON/SIGNAL/FREQ. SHIFT**) and a red LED on the control unit's emergency stop panel.

- The control unit is started with the sprung reset push button (**ON/SIGNAL/FREQ. SHIFT**)
- A warning signal is produced on the crane (**SIGNAL**) by holding the push button down.
- The warning signal can be issued at any time during operation.
- All movement of the crane is stopped if the emergency stop is activated on the control unit. The red LED indicates operating and battery status.

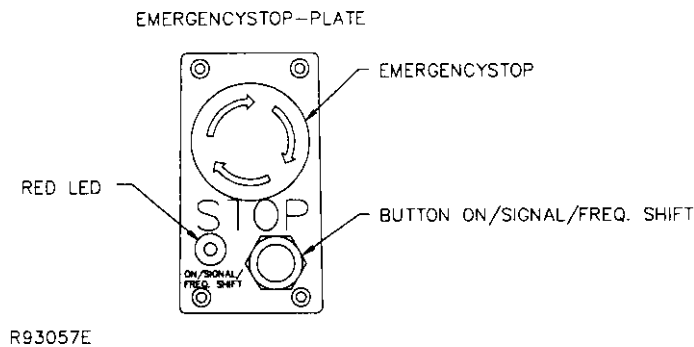

Switch panel (Micro-speed, ON/OFF and function change functions).

The control unit can be equipped with different switch panels, depending upon the particular installation.

There is a switch for micro-speed operation, i.e. speed control, as standard on all switch panels. Switch panels are equipped with different types and combinations of switches for ON/OFF manoeuvring or for function changing.

Alternative: One switch can be used to designate that levers will give ON/OFF functions (function changing).

Micro - Speed control (reduction of speed).

This return sprung switch can be used to reduce the operating speed in five (5) steps from 100% to 60%, 50%, 40%, 30% and 20% speed by limiting the hydraulic steering. The regulation of the function's speed is still made over the entire lever stroke and with retained resolution.

- With impulses from the sprung loaded toggle switch to the left, towards ON, speed reduction can be produced from 100% to 60%, 50%, 40%, 30% and 20% steering.
- Movement of the switch to the right, towards OFF, will produce 100% steering once again (See also next item).
- For safety reasons, a return to 100% steering can only be made if all manoeuvre levers are in their zero positions.
- **NOTE !!** If the emergency stop is pressed on the control unit, the control unit will restart from the normal position, i.e. 100% steering.
(As visible acknowledgement that micro operation is selected, the control unit's red LED will light for a long period and then extinguish for a short period, this sequence then being repeated. Do not mistake this for "low battery capacity").

ON/OFF and function changing functions.

ON/OFF switches can be used to manoeuvre electrical, hydraulic or pneumatic ON/OFF functions.

Examples of functions :

- Stopping and starting of the vehicle's motor, throttle lever, beep / signal, change-over valves, function changing for ex. 7th and 8th function.
- Enable parallel running of two or more valves at the same time from one manoeuvre lever.
- Connection of so called hold function, i.e. "lock" a function at a specific speed, after which the speed is kept constant without the lever having to be held (for example hydraulically driven drills) etc. This can be compared to the speed control in a private car.

Make sure that you always know which functions are connected for ON/OFF manoeuvring.
Alternative: One switch can be used to designate that levers will give either proportional or ON/OFF functions (function changing).

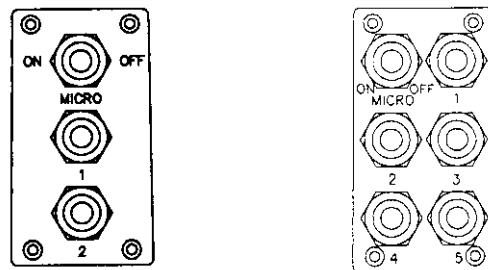

3. CABLE FOR CABLE CONTROL (electrical 3-core).

The control unit is connected to the electronicbox via a thin and flexible 3-core cable. The cable has round contacts (Amphenol / Hirschmann) at each end. The cable feeds the digital coded control information from the control unit to the electronic box. The cable is available in standard lengths of 10 , 15 , 25 , 50 and 100 metres.

*With cable control, the standard cable length supplied is 15 metres .
 A 10 metre control cable is supplied with opto or radio control, for emergency operation.*

(1 = Supply , 2 = Data , Ground = Ground/Minus , 3 = No connection).

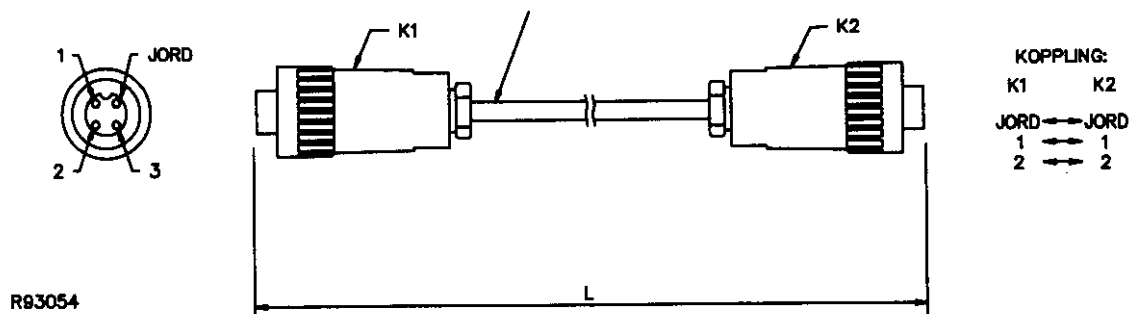

R93054

4. CABLE FOR OPTO FIBRE OPERATION (NOTE ! OPTION).

For opto fibre control the remote control system is complemented with an opto fibre cable, battery pack and battery charger. This means that light is used to send the control information (not electrical impulses).

The control unit is connected to the electronicbox via a thin opto fibre cable. The cable has circular type contacts (Amphenol / Hirschmann) at each end and the opto fibre electronics is built in and integrated into the contacts.

Opto fibre cable is used in those cases where the use of traditional control cable is not allowed. This can be during work under or near to electrical power lines or ground cables where contact or flash-over between control unit and crane could be fatal.

With opto fibre cable the control unit and electronicbox (crane / vehicle) are not electrically connected, i.e. are totally isolated and galvanically separated.

(Radio control gives the same personnel protection).

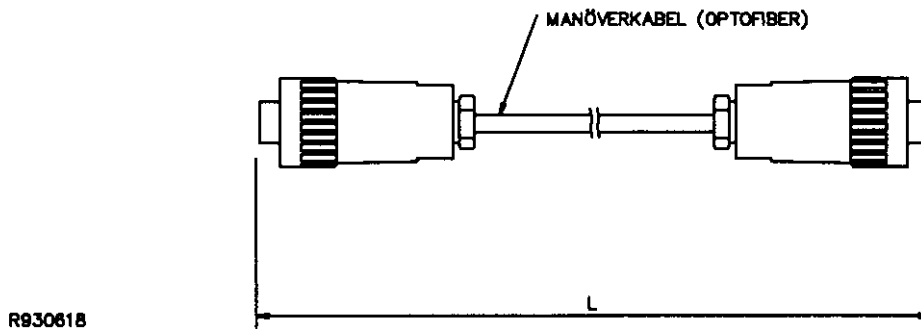

5. ELECTRONICBOX.

The electronicbox is manufactured in aluminium and is provided with attachments and contacts for connection to the portable control unit, radio receiver box and ON/OFF functions. There are also connections and contacts for supply voltage, electro-hydraulic converter valves, slide controls and dump valve. Since the electronicbox can be exposed to very tough environments, the box is encapsulated to give protection from damp, heat, cold, dust, vibration and corrosive environments.

The electronicbox has short circuit proof inputs and outputs and has protection against polarity reversal, over-voltage and large incoming voltage transients and EMC / RF. Connection of the electronicbox can therefore be made without risk of damage. The electronicbox is delivered for supply voltages of +12 / +24 VDC (+/- 20 %) with negative ground. There are two standard car type fuses located inside the electronicbox.

Plus fuse: + 10 Amp. and minus fuse: - 30 Amp.

A transformer for standard mains voltages can also be used to provide the electronicbox with supply voltage. Primary voltage: 110, 115, 220-240, 380, 440 VAC and secondary voltage + 12 / +24 VDC (+/- 10%).

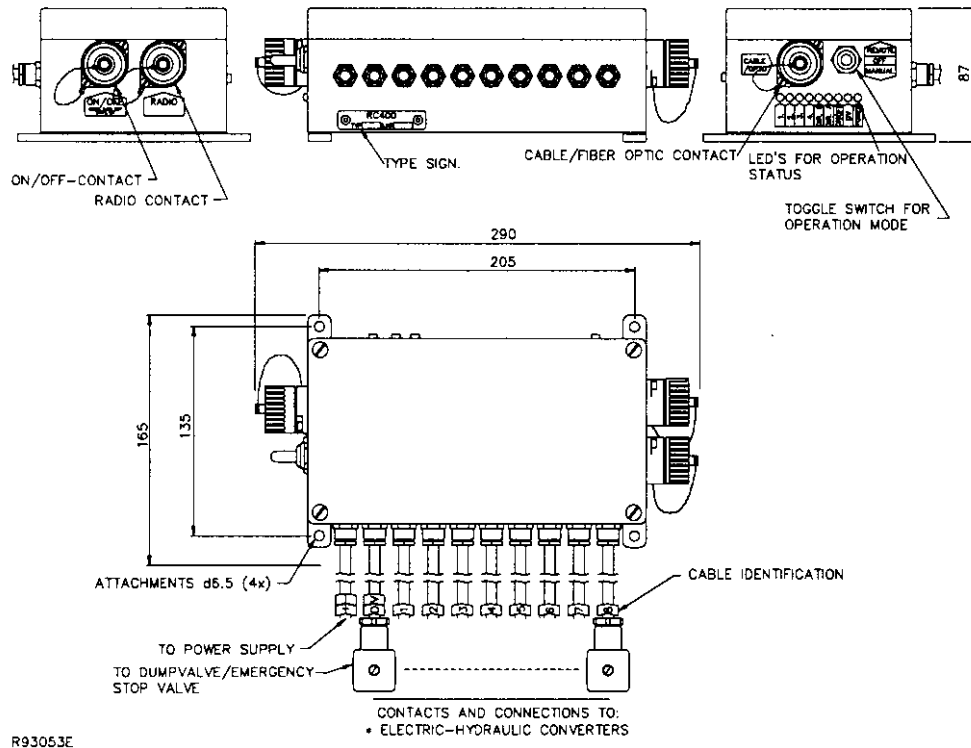

There are LEDs on the electronicbox to indicate operating status e.t.c : See also page : 5-2 !!!

POWER: Indicates supply voltage to the electronicbox (*toggleswitch in REMOTE position*).

DV: Dump-Valve activated.

ON/OFF: ON/OFF function activated. The LED is commoned and summed, i.e. only one switch at a time can be activated from the control unit to enable control.

DIR. A: Manoeuvre lever A-direction activated and moved . The intensity of the light from LED-A increases with increased lever angle. The LED is commoned and summed, i.e. only one manoeuvre lever at a time can be manoeuvred in the A-direction to enable control.

DIR. B: Manoeuvre lever B-direction activated and moved . The intensity of the light from LED-B increases with increased lever angle. The LED is commoned and summed, i.e. only one manoeuvre lever at a time can be manoeuvred, in the B-direction to enable control.

6. EX-CABLE (EX).

A thin and flexible 7-core cable can be connected to the electronicbox for outgoing ON/OFF-functions, for in-going signal handling e.g. overload and lift reduction functions and for serial communications if more than one electronicbox is used in so called tandem operation. The cable has a circular type contact (Amphenol / Hirschmann) at one end.

(The EX-cable is marked with the letters **EX** and should be connected to the ON/OFF connector on the electronicbox).

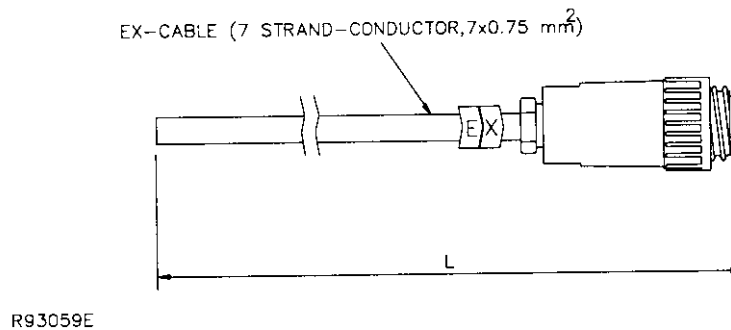

7. CRANE EMERGENCY STOP BOX / MAIN EMERGENCY STOP.

The crane emergency stop box is a separate unit for fixed mounting on the vehicle. The crane emergency stop box must be connected between the vehicle battery and the electronicbox.

- When an emergency stop is activated the main power supply to the entire remote control system is disconnected.
- The crane emergency stop must be suitably located and easily accessible.
- Before operation is started, the driver must inform all fellow-workers about the emergency stop function and its location.

With the electronicbox switch in MANUAL position and an electric dump valve, the emergency stop function is also available during manual hand lever operation.

(See also chapter 5. "Safety regulations and Operating instructions").

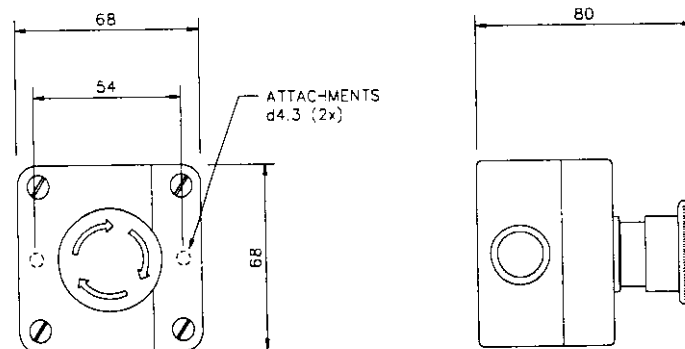

EMERGENCYSTOP TYPE: TELEMECANIQUE XAL-J174

8. BATTERY PACK.

The battery pack is impact and weather resistant and is located in the battery holder in the portable control unit . The battery pack is rechargeable and of NickelCadmium (NiCd) type. The battery pack is protected against short circuits. The terminal voltage of a newly charged battery should be (unloaded) ca 7.0 - 9.0 VDC.

Note.

Battery packs supplied since 1 January 1993 have three (3) terminal connections. The centre terminal is used for Scanreco's quick charger (*option*).

The battery pack is fully compatible with all battery packs previously supplied.

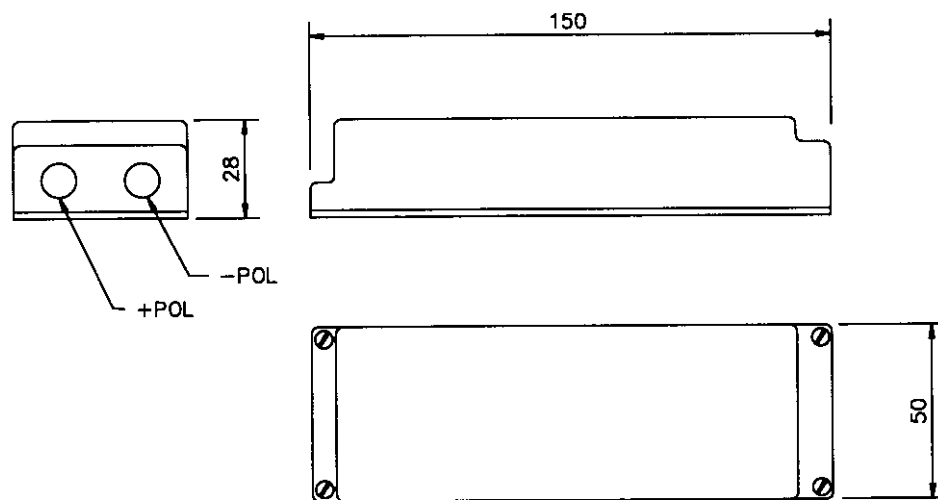

R930510

- The effective operational capacity of the battery is approximately 8 hours per charge.
- When the battery is approaching time for recharging, the control unit beeps THREE (3) TIMES as a warning and at the same time the LED starts to blink on the control unit. See next item.
- The battery must be used until the LED goes out, after which it can be changed. If the battery capacity is too LOW the control unit cannot be activated.
- The battery capacity and operational performance is reduced in extremely cold conditions. (The battery is automatically charged during operation by cable control).
- In order to reduce battery loading and for safety reasons, the control unit is turned off automatically, after the unit has been idle for more than approximately five (5) minutes.

9. BATTERY CHARGER AND BATTERY CHARGING.

The battery charger must be mounted in a vibration free area inside the cab or indoors and be protected against damp and temperature variations.

- The normal charging time for an empty uncharged battery, is approximately 12-14 hours.
- The battery charger should be connected directly to the vehicle battery to enable charging during idle time.
- The batter charger is constructed so that no damage will occur from long continuous charging.
- The supply voltage to the battery charger should be +11 VDC to +30 VDC.

There are two indicating LEDs on the battery charger :

- **RED LED (POWER)** : indicates supply power available (i.e. from the vehicle battery).
- **GREEN LED (CHARGING)** : indicates that charging is taking place.

A fuse-holder (bayonet type) is located next to the connecting cable and contains a glass fuse 3 Amp. (quick), size 5 x 20 mm .

Polarity for the connecting cable: + Blue and - Brown.

The battery charger current without battery pack is: $\approx 10 - 20 \text{ mA}$.

The battery charger current with battery pack is: $\approx 130 - 140 \text{ mA}$.

The terminal voltage at the battery charger terminals is approximately the same as the vehicle battery voltage.

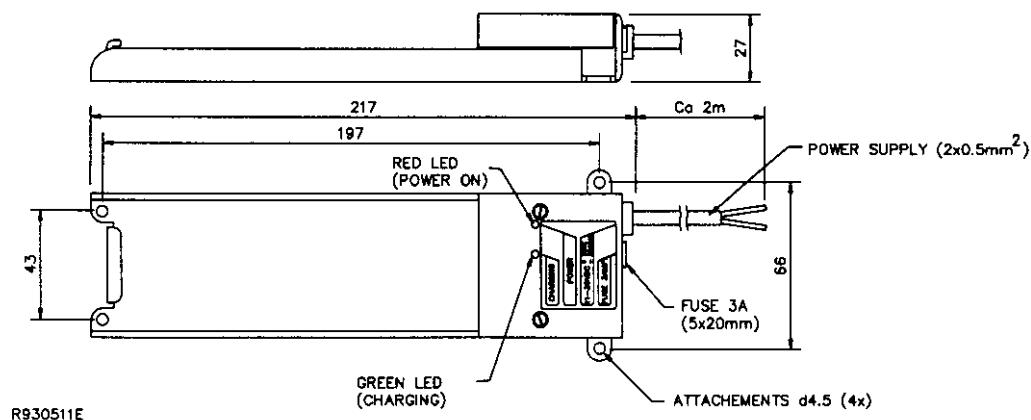

Defective / non-functioning battery charger:

If the driver is using cable control and the battery pack is in place in the control unit, the battery will be charged automatically. See also below.

Battery charging via cable control, for ex. over night : (*Charging time is approx. 12-14 hours*).

Place the battery pack in the control unit (*emergency stop depressed*) and connect the cable between the control unit and the electronicbox (*emergency stop on the crane activated*).

The electronicbox must be in **Remote** : (**Power**, and LED No. 4 should blink). Battery charging is now taking place !

10. RADIO CONTROL (See "11. Radio transmitter" and "12. Radio receiver box").

For radio control operation the remote control system is complemented with a radio transmitter, a battery pack, battery charger and radio receiver box.

(See also sections "Battery pack", "Battery charger" and " Control unit for battery operation").

11. RADIO TRANSMITTER.

The radio transmitter card (which is encapsulated and has a well proven built-in antenna) is mounted onto the control unit electronics card (HTX 402). The radio transmitter is connected via a pin strip, to the electronics card and is screwed down using four fixing spacers. When the radio transmitter is connected to the electronics card (HTX 402), a unique identity code is added automatically to the digitally coded control information. The radio transmitter is approved in accordance with European radio standards I-ETS 300 220 and I-ETS 300 683. The driver can make an immediate radio channel change by using control unit push button "ON/SIGNAL/FREQ.SHIFT". The radio channel change can be made at any time during operation. The radio transmitter operates in the 405 - 490 Mhz band.

For the mobile market 12 (twelve) radio channels in the I.S.M band (433.100-434.700 á 25kHz) are available for use.

No special licence is required by the user for the frequencies for which the radio transmitter is approved.

Changing the radio channel : A double press of the (FREQ. SHIFT) push button will make the system execute an immediate radio channel change. Press the button twice quickly and the red LED should blink and the control unit should beep once to confirm that a radio channel change has been made. A radio channel change can be made at any time during operation. The system has twelve (12) radio channels as standard .

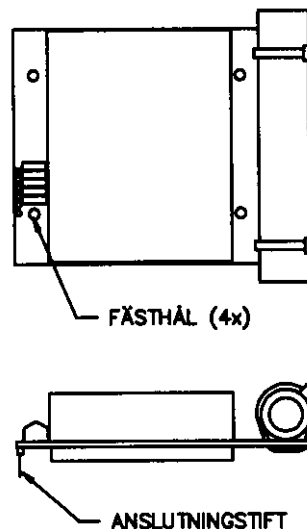

R93063

12. RADIO RECEIVER BOX.

The radio receiver box is manufactured in aluminium and is provided with attachments, well proven antenna and a connector for connection to the electronics box. Since the radio receiver box can be subjected to a very tough environment, the box is encapsulated for protection against damp, heat, cold, dust, vibration and corrosive environments. A green LED on the radio receiver box indicates supply voltage (the radio receiver box receives its supply voltage from the electronicbox).

When the radio receiver box is connected to the electronicbox, a unique identity code is automatically added to the digitally coded control information.

The radio receiver box is approved in accordance with European radio standards I-ETS 300 220 and I-ETS 300 683. With the use of the control unit push button "ON/SIGNAL/FREQ.SHIFT" the driver can make a direct change of radio channel. A radio channel change can be made at any time during operation. The radio receiver box operates in the 405 - 490 Mhz band. 12 (twelve) radio channels are available in the I.S.M band (433.100-434.700 á 25kHz) for mobile operation.

No special licence is required for the user for the frequencies for which the radio receiver box is approved.

(The connecting cable for the radio receiver box is marked with the letters **RA** and should be connected to contact **RADIO** on the electronicbox).

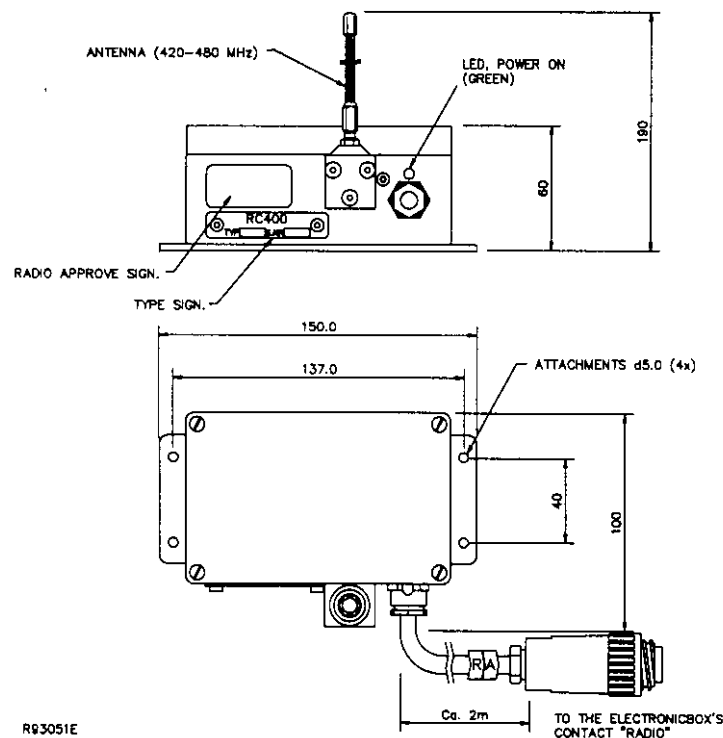

3. SAFETY REGULATIONS AND OPERATING INSTRUCTIONS.

These instructions cover, amongst other things, those special regulations which apply for remotely controlled cranes (cable or radio). The driver must be aware of the contents of these safety regulations.

Remote controlled cranes may only be operated by trained personnel. The portable control unit must never be passed over to any person who has not received training for remote controlled cranes. If these instructions are not followed, serious accidents can occur!

THE CRANE DRIVER MUST :

- Check that the control unit matches the crane / vehicle which he is to operate.
- Acquaint himself with the symbols and positions for operating functions and directions.
- Check the emergency stop function and general remote control system operation daily .
- During operation, walk or stand at a suitable distance from the crane to be able to get a good view of the operation. No unauthorised persons may be within the crane's working area.
- Be aware that it is forbidden to convey loads over himself or fellow workers.
- Release all manoeuvre levers (*dead-man's-handles*) if crane movement control is lost and then immediately press the emergency stops on the control unit and on the crane.
- The emergency stop on the control unit should always be in the depressed position whenever the unit is not in use. This applies even for short stoppages, for example, if the driver wishes to move.
- After a completed run, press the emergency stop on the control unit and on the crane. The control unit must be kept out of reach of unauthorised persons.
- Always report equipment faults or shortcomings to the person responsible for the crane.
- Check that none of the safety devices have been altered or removed.
- Refer to the current regulations / instructions regarding "*Personnel lifting with cranes* ", "*Overloading/overload protection* ", "*Visible signals during the operation of cranes* " and "*The location of cranes close to airports and high-tension power lines* " .
- Be aware of any other pertinent regulations and of any local regulations which may apply. These are to be found in the relevant safety regulations regarding crane transport.
- Be aware of the contents in "OPERATING INSTRUCTIONS" and the handling and method of working of the remote control system. See next page " Operating instructions " !

OPERATING INSTRUCTIONS.

Before operation, the driver **MUST** make himself aware of the contents in the "SAFETY REGULATIONS" for remotely controlled cranes. The driver must be aware of the function of all manoeuvre levers and switches.

1. For remote control: Place the electronic box power switch into **REMOTE**.

For manual/emergency operation: Place the electronic box power switch into **MANUAL**.
(Power is now only supplied to the dump valve and the crane's functions can be manoeuvred directly from the valve's hand levers).

Twist up the emergency stop switches on the crane and on the control unit.

Cable operation: Connect the control cable between the control unit and the electronics box (crane).

Radio operation: Place a newly charged battery in the control unit's battery holder.

3. Press **ON/SIGNAL/FREQ.-SHIFT**, and the red LED will light continuously.
4. The crane is now ready for operation. The driver must be aware of all manoeuvre lever and switch functions before operation is started.
5. To switch off or to activate the emergency stop the emergency stop switches on the control unit and crane should be pressed down. The emergency stop on the control unit should always be in the depressed position whenever the unit is not in use. This applies even for short stoppages, for example, if the driver wishes to move.
6. To ensure a long life for the control unit and for reasons of safety, the control unit must be kept locked in the cab. (The control unit should be regularly wiped off with a damp cloth for example).

4. INSTALLATION INSTRUCTIONS.

Contents :	Page :
• General schematic of the RC 400 / During <u>welding</u> .	4.2
• Locating the electronicbox and radio receiver box.	4.3
• Mounting recommendations for the radio receiver box.	4.4
• Connection of Danfoss electro-hydraulic valve and dump valve.	4.5
• Connection of proportional magnets and dump valve.	4.5
• Connection of supply voltage and ON/OFF functions.	4.6
• Connection schematic for ON/OFF functions (<i>see also page 4.6</i>).	4.7
• Connection schematic for start of vehicle motor and start lock.	4.8
• Connection schematic for valve contacts to Danfoss valves.	4.9
• Connection schematic for battery charger.	4.10
• Changing crane direction (If crane movement reversed to that desired).	4.11

When installing remote control on vessels/boats (marine cranes).

- Grounding of electronicbox and radio receiver box. 4.4 - 4.5

Technical data :

- Portable control unit, electronicbox and radio receiver box 4.15

Installation instructions for Scanreco RC 400 remote control system .

When the Scanreco RC 400 is installed an electrically controlled dump valve must, for reasons of safety, always be connected between the manoeuvre valve and the tank . This means that during an emergency stop manoeuvre the dump valve will be without power and will transfer the pump flow directly to the tank thus making the crane entirely without hydraulic pressure.

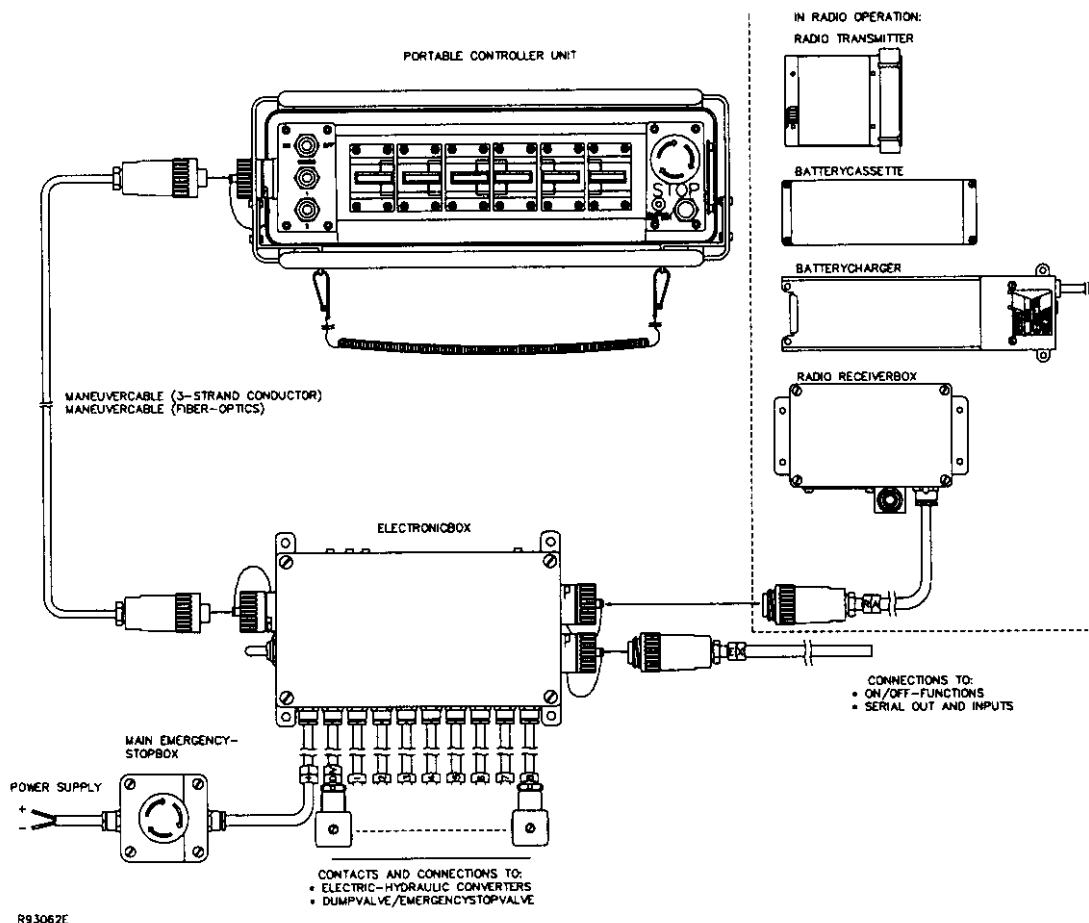

Welding.

It is sometimes necessary to weld a truck/machine. During welding the system's electrical connections must always be disconnected from other equipment, i.e. power supply cables (+ and -), all valve contacts, the EX cable and radio receiver box contact must be disconnected.

1. Before installation is started, it is recommended that a test run is made of the existing crane system (movement and functions) in order to discover existing faults or operational disturbances in the crane, hydraulic valves or other functions. Note these and notify the customer if any faults are found.

Installation and mounting instructions.

Electronicbox :

Important: The electronicbox must be mounted in accordance with the recommendations given below! To ensure the longest possible life for the electronicbox and its cables, the electronicbox must always be mounted so that the valve contacts are located facing downwards. The electronicbox must not be mounted so that the cables face upwards. The reason for this is to hinder water from running via the cables, towards the electronicbox. (The cables on the electronicbox are thus not subjected to long periods of accumulated water, damp, salt etc.). The electronicbox should be mounted in a vibration free location and not close to strong heat sources (for example exhaust pipes etc.). **See also page 4.5 - 4.6 !**

OK

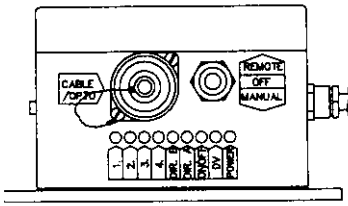

OK

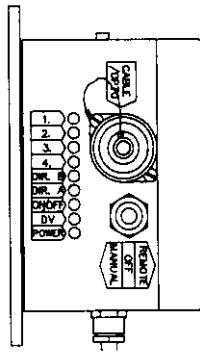

WRONG

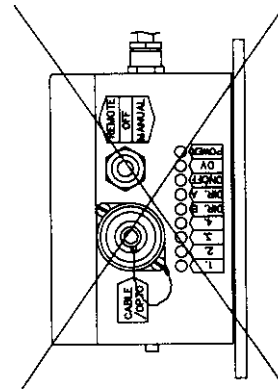

Radio receiver box :

Important: The radio receiver box must be mounted in accordance with the recommendations below!

The radio receiver box must be mounted in a vibration free location and not close to strong sources of heat (for example exhaust pipes etc.). **See next page !**

OK

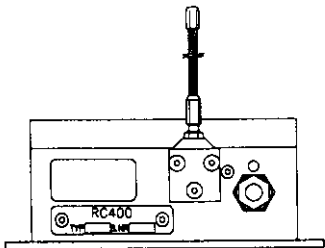

WRONG

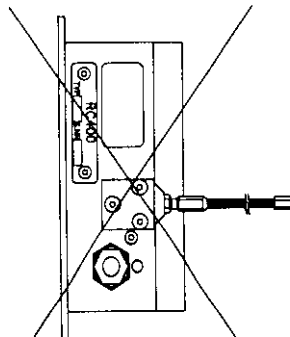

WRONG

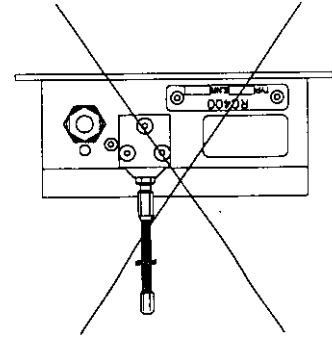

Mounting of the radio receiver box.

- The connection cable (*marked RA*) for the radio receiver box is approximately 2 metres long which is the maximum mounting distance from the electronicbox.
- For optimum radio communications the radio receiver box should be located as high and free as possible. An antenna screened and surrounded by fixed objects will considerably impair radio reception.
- The antenna pin must not touch any metal object. The radio receiver box should be mounted horizontally with the antenna pin sticking vertically up. (*See instructions !*).
- The radio receiver box should be mounted in a vibration free location and not be subjected to strong sources of heat (for example exhaust pipes etc.).

Control units and electronicboxes with the same serial number have been programmed with a unique "identity code" when delivered, i.e. they do not need to have their identity codes programmed. See section "Identity code programming" if this is not the case.

NOTE! Marine cranes : The casing of the radio receiver box is grounded and connected to supply voltage earth. In those special cases where a galvanically isolated earth is required (for ex. marine use), the radio receiver's box must be mounted on rubber stand-offs/bushes to obtain a galvanically isolated earth.

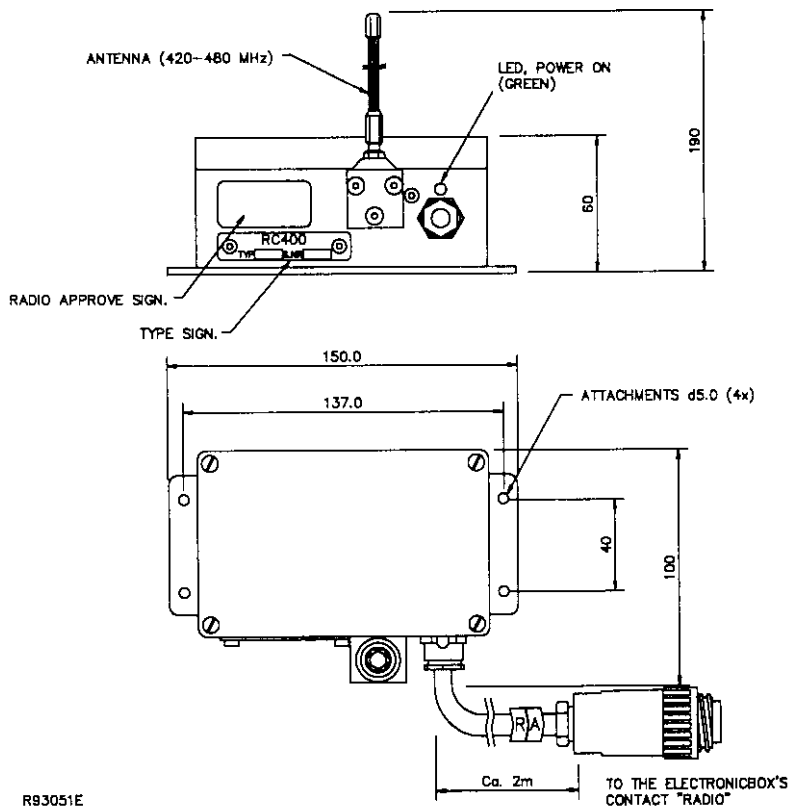

2. Select a suitable location for the electronic box on the vehicle / crane.
 - The contact for the cable control cable, switches for **MANUAL/ 0 / REMOTE** and LEDs for operational status must be located where they are easy to see and reach. Check that the electronic box cable contacts (*cable control, ON/OFF, and radio receiver box connection contacts*) are located so as to be protected from external damage.
 - If the electronic box is to be mounted in any other manner, the connections and contacts must not face upwards ! This is to hinder long-term accumulations of water, damp and corrosive salt in the cables, connections and contacts.

NOTE! Marine cranes : The casing of the electronic box is grounded and connected to supply voltage earth. In those special cases where a galvanically isolated earth is required (for ex. marine use), the radio receiver's box must be mounted on rubber stand-offs/bushes to obtain a galvanically isolated earth.

3. Connect the electronic box valve contacts, as per the schematic in which each valve group and function can be seen. A valve gasket is mounted under each valve contact and to prevent future operational disturbances, a weatherproof grease / silicon should be applied between the valve contact and the manoeuvre valve.
 - The valve contacts for the electro-hydraulic slide controller are marked and numbered 1, 2, 3 up to 8.
 (*The control unit's left manoeuvre lever 1 = valve contact 1*).
 (*The control unit's right manoeuvre lever 6 = valve contact 6*).
 - The valve contacts for the dump valve are marked **DV**. (*Max. output drive max. 2 Amp.*)
 (*The function is automatically cut off if loaded by more than 2 Amp., i.e. the output is not damaged*).
 - All cable and valve contacts must remain in place even for valve contacts which are not used. Unused valve contacts should be carefully sealed with grease and electrical tape (to keep damp out which could cause operational disturbances / alarms).

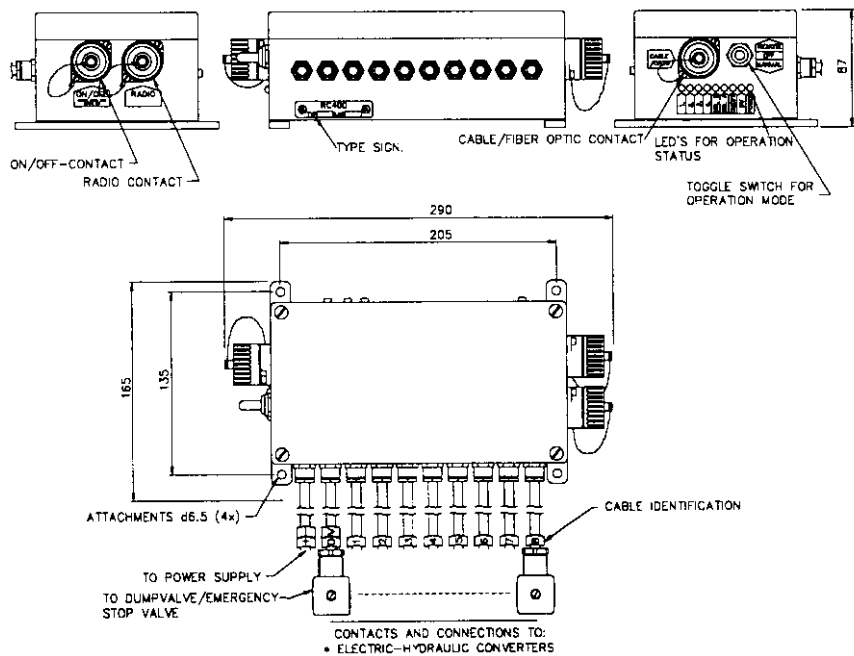

4. Next install any ON/OFF functions required. The ON/OFF cable is marked EX and should be connected to the "ON-OFF" contact on the electronicbox.

- Normal **ON/OFF function** usage is to drive a signal / beep function, throttle lever, changeover valves, motor start/stop etc. See connection recommendations for the starting of a motor !

Each **ON/OFF function** can drive a **maximum of 1.2 Ampere.**

- The output function is disconnected automatically if loaded by more than 1.2 Amp., i.e. the drive output is not damaged.
(For higher output drive an auxiliary relay can be mounted. See connection schematic for starting of vehicle motor).

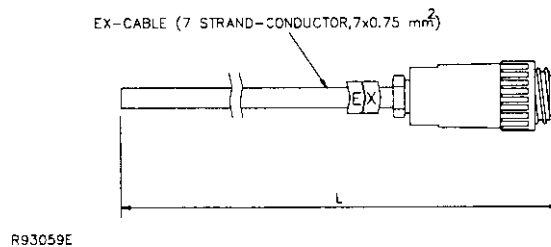

5. Connect the power supply cables via the crane emergency stop box to the electronicbox + supply voltage + and - to ground.

Cable number : 1 (+24 VDC , +/-20% , max. 5% V_{peak to peak}) *Marked* : +
Cable number : 2 (0 VDC / GROUND) * *Marked* : -

*Check that the same earth potential exists between the Scanreco earth cable (No. 2) and the vehicle's battery minus during max. loading (i.e. there is not a potential drop /difference as a result of poor earthing or the cable cross sectional area being insufficient).

Standard car type fuses are located inside the electronicbox. (Plus fuse: 10 Amp. and minus fuse: 30 Amp. Automatic fuses may NOT be used in the electronicbox).

Use supply cable with the correct dimension (**min. 1.5-2.5 mm²**), so that the cable bushings in the crane emergency stop box seal properly. Make sure that all cable terminals are well tightened.

For back end mounted cranes : Use supply cable of min. 2.5 -5.0 mm² !!!

Use **plenty of grease** in the emergency stop breaker and its screws and the supply cable. Connect power from the vehicle battery via the vehicle's ignition switch or power outlet.

Warning ! Volvo trucks which break main power on the **earth side** (not the plus side) : Make very sure that the electronicbox earth is connected correctly, i.e. that the earth for the electronicbox is also disconnected !!

Connection schematic for ON/OFF functions.

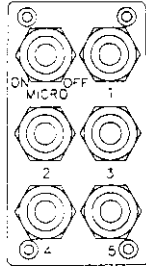

<u>Switch</u>	<u>EX cable No. :</u>	<u>Function / description :</u>
1 ON	No: 1	<u>Continuous full</u> working throttle.
1 Centre	No: -	Idle.
1 OFF	No: 1	<u>Automatic connection</u> of full throttle. ¹
2 ON	No: 2	Start vehicle motor. ²
2 OFF	No: 3	Stop vehicle motor.
3 ON	No: 4	RPM + or HPLS ON
3 OFF	No: 5	RPM - or HPLS OFF
ON/SIGNAL	No: 7	Signal / Beep / or Overload reset.

+ 24 VDC (1.2 Amp) is provided on each respective line on the EX cable after the respective ON/OFF function is activated from the control unit.

Note. An auxiliary relay is not normally required for ON/OFF functions except for starting of the vehicle motor. See recommended connection schematic on the next page. Page 4-8.

1. Automatic throttle control, i.e. throttle opening occurs at the same time that a manoeuvre is started with one of the levers. The throttle opening has a shut-down delay, i.e. it stays up for ca 6 seconds after the latest lever movement.
2. Start of motor, see recommended connection on the next page.

EX-CABLE (7 STRAND-CONDUCTOR, 7x0.75 mm²)

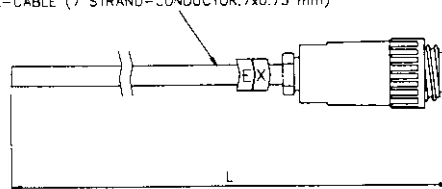

Connection of motor start / start lock :

- To protect the starter motor against unintentional re-start attempts after the vehicle motor has already started, it is recommended that an electric "start lock" is connected in after the motor start signal from the electronicbox, EX cable pin 2 (See connection example below).
- To be able to find out if the vehicle motor is already started, a signal can be taken, for example, from the generator. In this way the crane driver cannot activate the starter motor by mistake.
- Before connection, consult the truck manufacturer, customer and inspector !

Start lock / Protection relay.

Help relay.

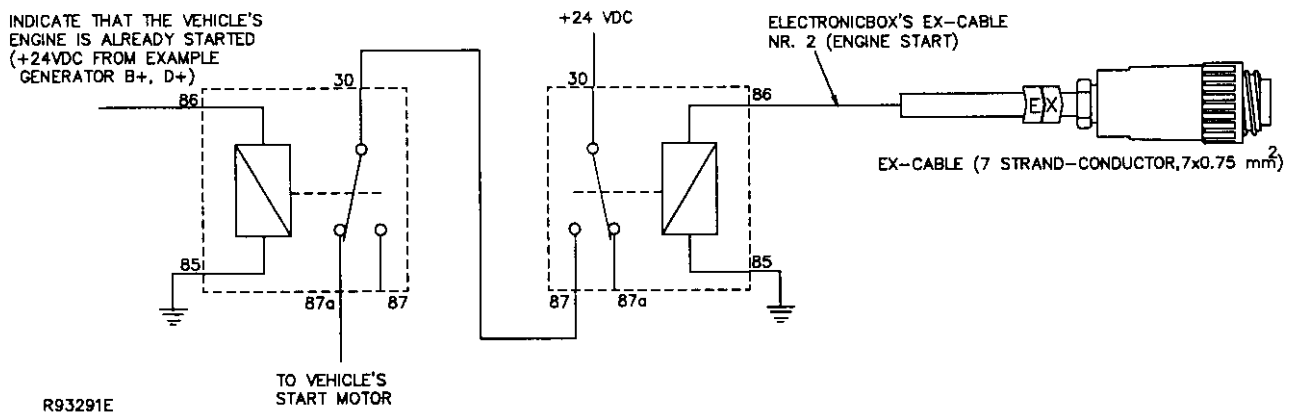

Description of start lock: (Example : Standard car relay, type Bosch).

- When an impulse is received from the portable control unit, +24 VDC is generated (EX no. 2) via the start lock relay, to the starter motor. When the motor has started, the start lock relay receives a voltage on pin 86 from the generator and the relay is pulled.
- If a new activation is made and an impulse is generated from the portable control unit the voltage will not reach the starter motor, since the start lock relay is activated, i.e. a start non-repeat lock.
- Generator connection : D+. This is only an example. Before connecting, contact the truck manufacturer !

Flying Jib / Extending jib :

During the manoeuvring of for example a jib / tool or reversing valve from the control unit the manual switch / breaker must always be activated. This is so that manual manoeuvring can be made if any fault should occur in the remote control system.

Connection schematic for Scanreco RC 400.

Control unit :

Left lever, 1A, 1B
 Right lever, 6A, 6B

Electronicbox :

Contact No: 1 (Valve contact, No: 1).
 Contact No: 6 (Valve contact, No: 6).

(Example : Swing, inner boom, outer boom, extension, accessory, rotator).

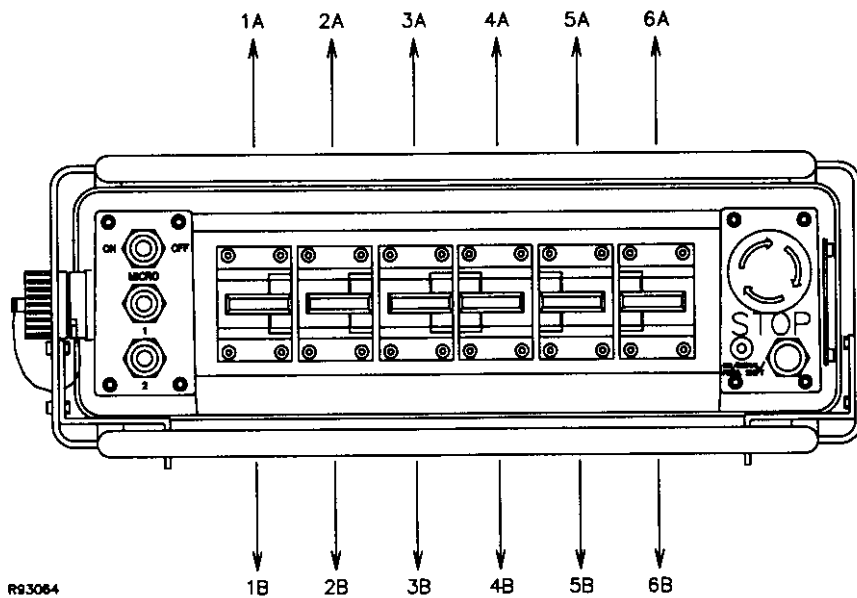
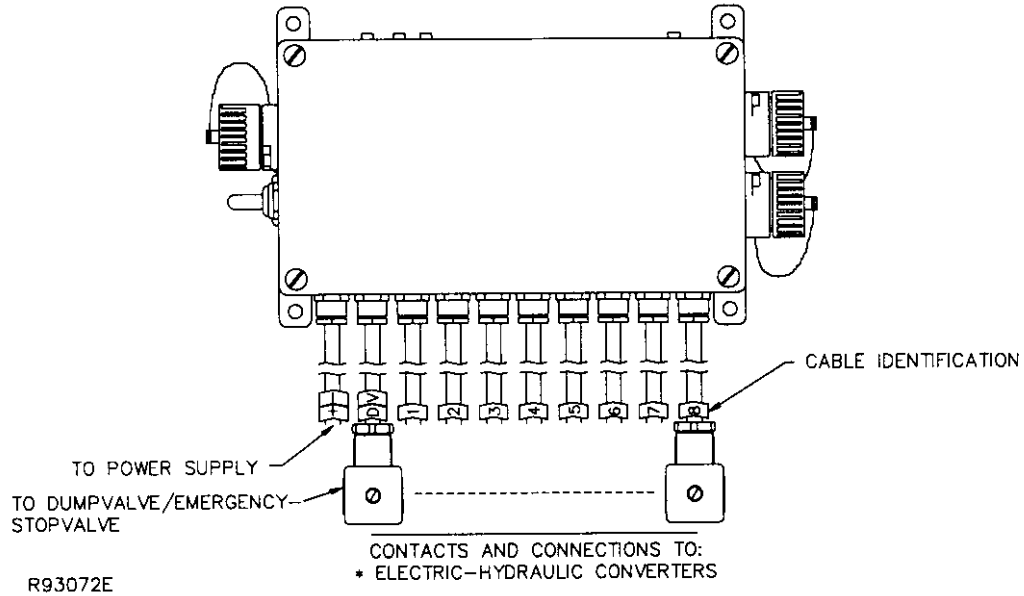

Option / extra (for 7th and 8th proportional functions).

Change function 5 to 7 = Valve contact 7 (Electronicbox).
 Change function 6 to 8 = Valve contact 8 (Electronicbox).
 (Change by using switch 4 , OFF = 5th and 6th functions , ON = 7th and 8th functions).
 The location of the change functions lever 1 - 6 , to 7- 8 , can be selected freely at delivery.

9. BATTERY CHARGER AND BATTERY CHARGING.

The battery charger must be mounted in a vibration free location inside the cab or indoors to give protection against damp and temperature variations.

- The normal charge time for an empty discharged battery is approx. 12-14 hours.
- The battery charger should be connected directly to the vehicle's battery to enable idle time to be utilised for charging.
- The battery charger is constructed so that the battery packs will not be damaged by long continuous charging.
- The supply voltage for the battery charger should be +11 VDC to +30 VDC.

There are two light emitting diodes (LEDs) on the battery charger :

- **A RED LED (POWER)** : indicates supply voltage present (i.e. from the vehicle battery).
- **A GREEN LED (CHARGING)** : indicates that charging is taking place.

A fuse-holder (bayonet type) is located next to the power cable with a glass fuse 3 Amp. (quick), with size 5 x 20 mm.

Polarity for connection cable: + Blue and - Brown.

Battery charger current without battery pack is: $\approx 10 - 20$ mA.

Battery charger current with battery pack is: $\approx 130 - 140$ mA.

Terminal voltage at battery charger terminals is approximately the same as the vehicle supply voltage

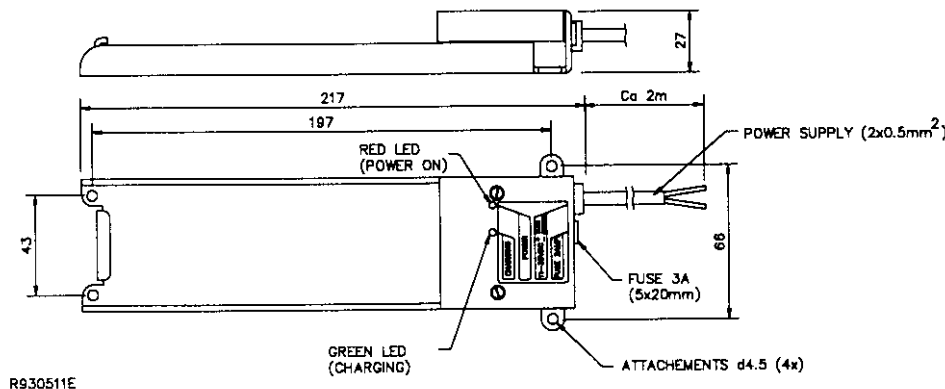

With defective / non-functioning battery charger:

If the driver is using cable control and the battery pack is located in the control unit, the battery will be charged automatically. See also below.

Battery charging via cable control, e.g. over night : (*Charging time is approx. 12-14 hours*).

Place the battery pack into the control unit (*emergency stop depressed*) and connect the cable between the control unit and the electronicbox (*crane's emergency stop twisted up*).

The electronicbox in Remote : (Power, and LED No 4 should blink). Battery charging is now taking place !

Changing the direction of crane movement.

The description which follows describes how to change the direction of movement if the crane moves in a different direction to that desired.

Example:

After installation and test operation it is found for example that the 3rd and 5th lever movements operate in the opposite direction to that desired. See the example below for how to change the 3rd and 5th lever movements.

DO AS FOLLOWS!

1. Remove the battery pack. Connect the cable between the control unit and electronic box and test run the crane. Then press the emergency stop on the control unit and emergency stop on the crane.
2. Twist up the emergency stop on the control unit and on the crane.
3. Press the control unit's ON/SIGNAL/FREQ.-SHIFT button.
(The red LED should light continuously).
4. Press spring return switch MICRO in very quick succession to the RIGHT *in the OFF direction* to produce impulses until the control unit gives a long beep signal. Wait approx. 12 seconds for a new long beep signal then continue with item 5.
Note 1. The red LED will be extinguished each time the control unit gives a beep signal.
Note 2. If you do not receive the first long beep signal, start again from item 1 and execute items 3. and 4. quicker. Items 3. and 4. must be executed within max. 5 seconds.
5. Now press ON/SIGNAL/FREQ.-SHIFT once.
(The control unit's built-in beeper will give a short beep once every 5 seconds to confirm that the items above have been done correctly. If any other beep signals are heard you must restart from item 1 again).
Now you can easily change the crane direction, see item 6.
6. Now you can operate the crane. Move the 3rd manoeuvre lever (which is operating in the opposite direction to that desired) away from zero position until the crane just starts to move and hold it there then give switch MICRO an impulse to the LEFT *in the ON direction*. The crane will now change direction and continue with the same selected speed, in the opposite direction. Do the same with the 5th manoeuvre lever.

Move the 5th manoeuvre lever (which is operating in the opposite direction to that which is desired) away from zero position until the crane just starts to move and hold it there and give toggle switch MICRO an impulse to the LEFT *in the ON direction*.

The crane will now immediately change direction and continue with the same selected speed in the opposite direction. *(If a direction change has been made earlier for a particular lever, do the same as above but give toggle switch MICRO an impulse to the RIGHT, in the OFF direction).*

Operate and check that all crane movement is now in the desired direction.

7. Press the emergency stop on the portable control unit. Programming is now completed and the crane is operating in the directions YOU decided in item 6. If you are not satisfied with any direction/directions, repeat these. See item 1.

General technical data :

For dimensions, see chapter 2 - "General system description".

Portable control unit:

Battery pack :	7.2 VDC.
Control unit effective operating time :	Approx. 8 hours per charge.
Weight :	1.6 kg (<u>without</u> battery pack and radio transmitter).
Weight:	1.9 kg (<u>with</u> battery pack and radio transmitter).

Electronicbox:

Supply voltage (<i>See order</i>) :	+ 24 VDC (+/- 20 % / max. 5% V peak to peak).
Max. over-voltage :	Approx. 33 VDC (Fuse blows).
Proportional functions :	1 - 8 double operating proportional functions.
Dump valve drive :	Max. 2,0 Ampere (short circuit proof).
ON/OFF drive :	Max. 1,2 Ampere (short circuit proof).
Regulation signal disconnected with:	Supply voltage + 24 VDC at 15 - 17 VDC.
Current consumption at Idle:	60 mA (<u>Without</u> radio receiver box).
	140 mA (<u>With</u> radio receiver box).

Total current consumption : See Danfoss catalogue for PVEO, PVEM, PVEH-current consumption !
Sum all current consumption, i.e. all PVEM/PVEH, ON/OFF functions, dump valve etc.

Fuses in electronics box : Plus : + 10 Amp. (Standard car fuse / Red).
Ground : - 30 Amp. (Standard car fuse / Green).

Battery charger :

Battery charger current consumption <u>without</u> battery pack is :	≈ 10 - 20 mA.
Battery charger current consumption <u>with</u> battery pack is :	≈ 130 - 140 mA.
Terminal voltage at battery charger terminals is :	≈ Vehicle supply voltage.

Fuse : Glass fuse 3 Ampere (quick), with size 5 x 20 mm.

Location : The fuse holder (bayonet type) is to be found beside the connection cable.

5. FAULT FINDING.

The crane driver should check the following before calling the service workshop.

	Page :
• Functional system / LEDs indication on Electronicbox.	5.2
• Always check this !	5.3
• Error messages on the electronicbox / actions.	5.4
• Electrical connection schematic for electronicbox cables.	5.5
• Electronicbox with lid removed.	5.6

The service workshop can check the following before Scanreco AB, Sweden is contacted.

	Page :
• Whole system not functioning (In depth fault finding).	5.7
• Control unit red lamp <u>not lit</u> continuously.	5.8 -
• Some proportional functions missing.	5.10 -
• Some ON/OFF functions missing.	5.12
• Test mode for control unit (Internal tests)	5.13 -
• Cable control works but not radio.	5.14
• Repair of control cable.	5.15
• Programming of ID code (Only authorised workshops).	5.16

INDICATIONS WITH FUNCTIONING SYSTEM.

The following LEDs must be lit on a functioning system :

(For other LED combinations and indications , see next page/pages !!).

A. Portable control unit turned off , the following LEDs light :

- "REMOTE" mode : (POWER LED lit and LED No 4 must blink).
- "MANUAL" mode : (Only DV).

B. Portable control unit activated , the following LEDs light :

(The red LED on the control unit must be lit continuously).

- "REMOTE" mode : (With radio operation : POWER , DV* , 2 , 3).
- "REMOTE" mode : (With cable operation : POWER , DV* , 2 , 3 , 4).

DV :When remote control is activated, the dump valve is also activated. If the manoeuvre levers remain in the neutral position for more than approx. 1 second, the dump valve will automatically be deactivated (i.e. the oil is dumped to the tank).
Later when one of the manoeuvre levers leaves the neutral position, the dump valve will be reactivated at the same time.*

(All manoeuvre levers and ON/OFF functions must be in the neutral position, i.e. not activated. During operation by radio , the GREEN LED on the radio receiver box must be lit).

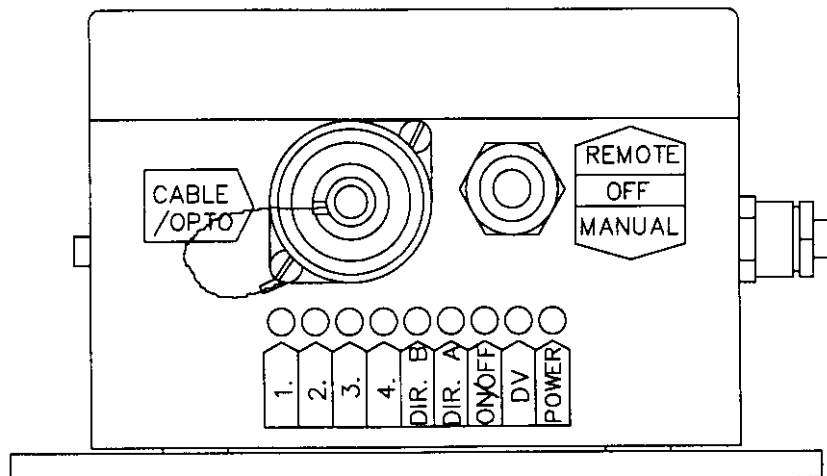

Always check this !

Always check this :

- Is there + 24 VDC, +/- 20 %, max. 5 %V_{peak to peak} supply to the system? Measure at the crane emergency stop switch (unloaded and loaded). See also page 4-6 !!!
 - Are the electronicbox fuses whole, i.e. + 10 Amp. (Plus) and - 30 Amp. (Ground) ?
Open electronicbox lid and check.
 - Does cable control function ?
 - Does the crane work manually, i.e. with the electronicbox power supply switch in "MANUAL" position ?
 - Place switch into " REMOTE " position.
 - Unscrew and remove the **EX** cable from the electronicbox.
 - Remove valve contact **DV** from the dump valve.
 - Remove valve contacts Nos. **1** to **8**.
 - **Answer item 2.**
2. When all these contacts are removed, which LEDs are lit on the electronicbox ?

The following LEDs are lit: _____

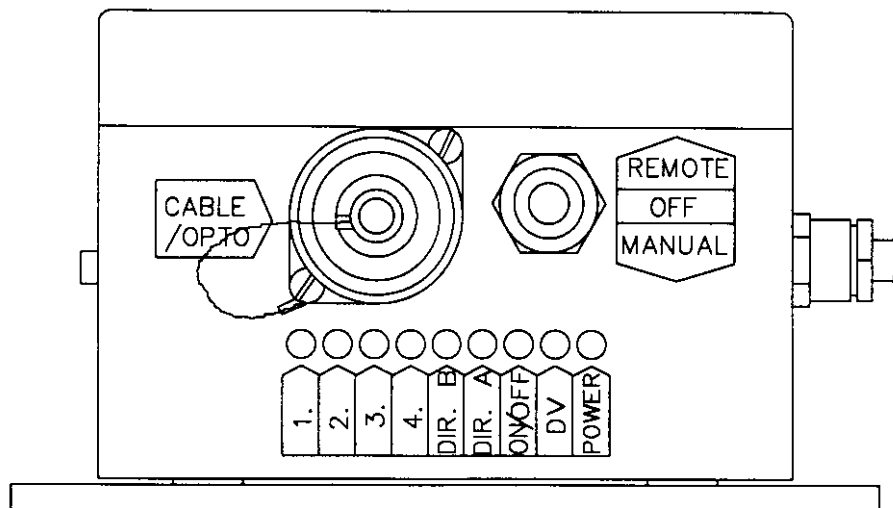

Error messages / Actions.

Simple error messages can be read with the help of the LEDs on the electronicbox. LEDs 1 - 4 are used to give error messages. The first LED (No.1) always blinks with errors and then a combination of lights is shown on LEDs 1 - 4 .

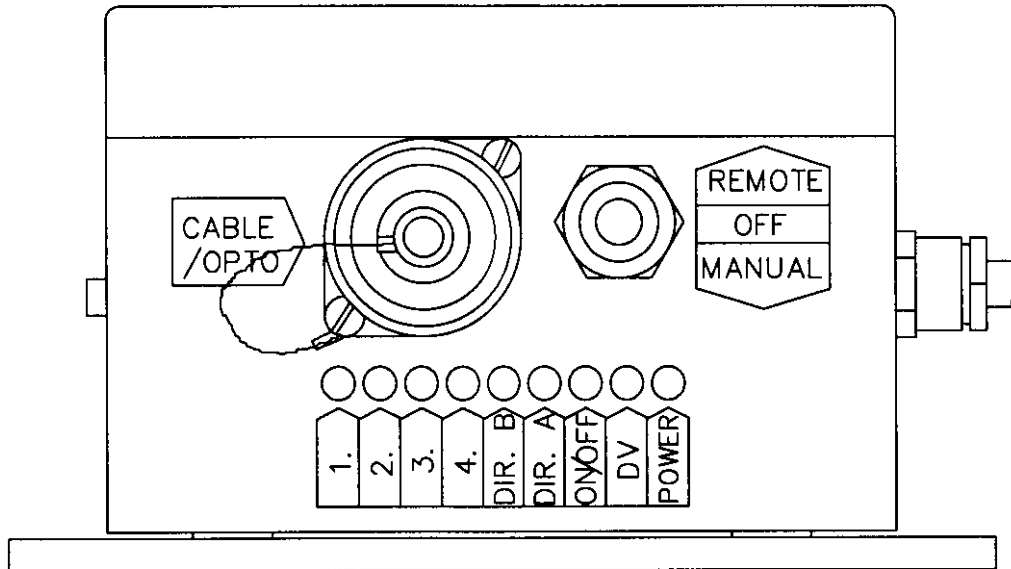

When the control unit is activated and the electronicbox switch is in " REMOTE " position do any of these LED combinations exist ?

<u>Error message :</u>	<u>Error source / Reason :</u>	<u>Action :</u>
LED 1, pause and then LED 2.	ON/OFF function. / Over-load.*	Unscrew EX cable.
LED 1, pause and then LEDs 2 and 4.	Dump-Valve (short circuit).	Remove valve contact DV.
LED 1, pause and then LEDs 2 and 3.	Danfoss electro-hydraulic unit (short circuit).	Remove valve contacts 1-8.
LED 1, pause and then LEDs 3 and 4.	Danfoss-regulator signal <u>invalid</u> action.	Remove valve contacts 1-8.
LED 1, pause and then LEDs 1 and 4.	Error supervision in PVEH <u>activated</u> .	Remove valve contacts 1-8.

* Load drawn by one of the ON/OFF outputs on the EX cable is more than 1.2 Amp. Check connection and magnetic winding.

Another combination is lit : _____

Electronicbox type and ser. no. : _____

Control unit type and ser. no. : _____

(A type label is located on the control unit, electronicbox and radio receiver box).

Error messages / Actions.

Simple error messages can be read with the help of the LEDs on the electronicbox. LEDs 1 - 4 are used to give error messages. The first LED (No.1) always blinks with errors and then a combination of lights is shown on LEDs 1 - 4 .

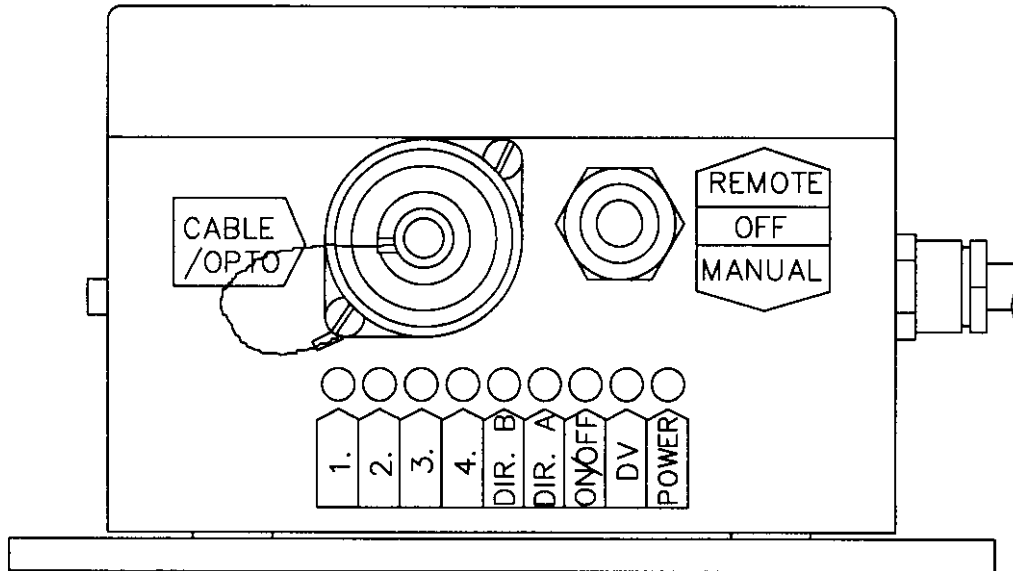

When the control unit is activated and the electronicbox switch is in " REMOTE " position do any of these LED combinations exist ?

<u>Error message :</u>	<u>Error source / Reason :</u>	<u>Action :</u>
LED 1, pause and then LED 2.	ON/OFF function. / Over load.*	Unscrew EX cable.
LED 1, pause and then LEDs 2 and 4.	Dump valve (short circuit).	Remove valve contact DV.
LED 1, pause and then LEDs 2 and 3.	Electro-hydraulicvalve / coil (short circuit).	Remove valve contacts 1-8.

* Load drawn by one of the ON/OFF outputs on the EX cable is more than 1.2 Amp. Check connection and magnetic winding.

Another combination is lit : _____

Electronicbox type and ser. no. : _____

Control unit type and ser. no. : _____

(A type label is located on the control unit, electronicbox and radio receiver box).

Connection schematic for electronic box with ready-made cables for Danfoss electro-hydraulic boxes : PVEM or PVEH.

Incoming supply voltage: + 24 VDC (+/- 20% , max. 5%V_{peak to peak})

Regulation range: 5,8 - 18,2 V (+ At 24,0 V)

Neutral position: + 12,0 VDC (+ At 24,0 V)

Incoming supply voltage:

2 Incoming : Ground / 0 VDC.

1 Incoming : + 24 VDC (See above)

Dump valve :

2: Ground, dump valve.

1: Plus drive, dump valve.

Movement 1. (Scanreco's cable and cable number in valve contact).

1 Outgoing supply voltage for PVEM or PVEH / Danfoss pin No: 1.

2 Regulated voltage for PVEM or PVEH / Danfoss pin No: 2.

Yellow/green Outgoing ground (0 VDC) for PVEM or PVEH / Danfoss pin No: Ground.

3 *Option (Error supervision PVEH) / Danfoss pin No: 3.*

Movement 2. (Scanreco's cable and cable number in valve contact).

1 Outgoing supply voltage for PVEM or PVEH / Danfoss pin No: 1.

2 Regulated voltage for PVEM or PVEH / Danfoss pin No: 2.

Yellow/green Outgoing ground (0 VDC) for PVEM or PVEH / Danfoss pin No: Ground.

3 *Option (Error supervision PVEH) / Danfoss pin No: 3.*

Movement 3. (Scanreco's cable and cable number in valve contact).

1 Outgoing supply voltage for PVEM or PVEH / Danfoss pin No: 1.

2 Regulated voltage for PVEM or PVEH / Danfoss pin No: 2.

Yellow/green Outgoing ground (0 VDC) for PVEM or PVEH / Danfoss pin No: Ground.

3 *Option (Error supervision PVEH) / Danfoss pin No: 3.*

Movement 4. (Scanreco's cable and cable number in valve contact).

1 Outgoing supply voltage for PVEM or PVEH / Danfoss pin No: 1.

2 Regulated voltage for PVEM or PVEH / Danfoss pin No: 2.

Yellow/green Outgoing ground (0 VDC) for PVEM or PVEH / Danfoss pin No: Ground.

3 *Option (Error supervision PVEH) / Danfoss pin No: 3.*

Movement 5. (Scanreco's cable and cable number in valve contact).

1 Outgoing supply voltage for PVEM or PVEH / Danfoss pin No: 1.

2 Regulated voltage for PVEM or PVEH / Danfoss pin No: 2.

Yellow/green Outgoing ground (0 VDC) for PVEM or PVEH / Danfoss pin No: Ground.

3 *Option (Error supervision PVEH) / Danfoss pin No: 3.*

Movement 6. (Scanreco's cable and cable number in valve contact).

1 Outgoing supply voltage for PVEM or PVEH / Danfoss pin No: 1.

2 Regulated voltage for PVEM or PVEH / Danfoss pin No: 2.

Yellow/green Outgoing ground (0 VDC) for PVEM or PVEH / Danfoss pin No: Ground.

3 *Option (Error supervision PVEH) / Danfoss pin No: 3.*

Movement 7. (Scanreco's cable and cable number in valve contact).

1 Outgoing supply voltage for PVEM or PVEH / Danfoss pin No: 1.

2 Regulated voltage for PVEM or PVEH / Danfoss pin No: 2.

Yellow/green Outgoing ground (0 VDC) for PVEM or PVEH / Danfoss pin No: Ground.

3 *Option (Error supervision PVEH) / Danfoss pin No: 3.*

Movement 8. (Scanreco's cable and cable number in valve contact).

1 Outgoing supply voltage for PVEM or PVEH / Danfoss pin No: 1.

2 Regulated voltage for PVEM or PVEH / Danfoss pin No: 2.

Yellow/green Outgoing ground (0 VDC) for PVEM or PVEH / Danfoss pin No: Ground.

3 *Option (Error supervision PVEH) / Danfoss pin No: 3.*

Connection schematic for electronicbox for proportional coils / electro-hydraulic slides.

Incoming supply voltage: + 24 VDC , +/- 20% max. 5%Vpeak to peak

Cable numbering in electronicbox / Cabling :

Incoming supply voltage:

- 2 Incoming : Ground / 0 VDC.
- 1 Incoming : + 24 VDC (See above)

Dump valve :

- 2: Ground, dump valve.
- 1: Plus drive, dump valve.

Movements 1A and 1B.

- 2 1A , Ground.
- 1 1A , Current signal (PWM).
- 2 1B , Ground.
- 1 1B , Current signal (PWM).

Movements 2A and 2B.

- 2 2A , Ground.
- 1 2A , Current signal (PWM).
- 2 2B , Ground.
- 1 2B , Current signal (PWM).

Movements 3A and 3B.

- 2 3A , Ground.
- 1 3A , Current signal (PWM).
- 2 3B , Ground.
- 1 3B , Current signal (PWM).

Movements 4A and 4B.

- 2 4A , Ground.
- 1 4A , Current signal (PWM).
- 2 4B , Ground.
- 1 4B , Current signal (PWM).

Movements 5A and 5B.

- 2 5A , Ground.
- 1 5A , Current signal (PWM).
- 2 5B , Ground.
- 1 5B , Current signal (PWM).

Movements 6A and 6B.

- 2 6A , Ground.
- 1 6A , Current signal (PWM).
- 2 6B , Ground.
- 1 6B , Current signal (PWM).

(PWM = *Pulse Width Modulated*)

Electronics box with lid removed.

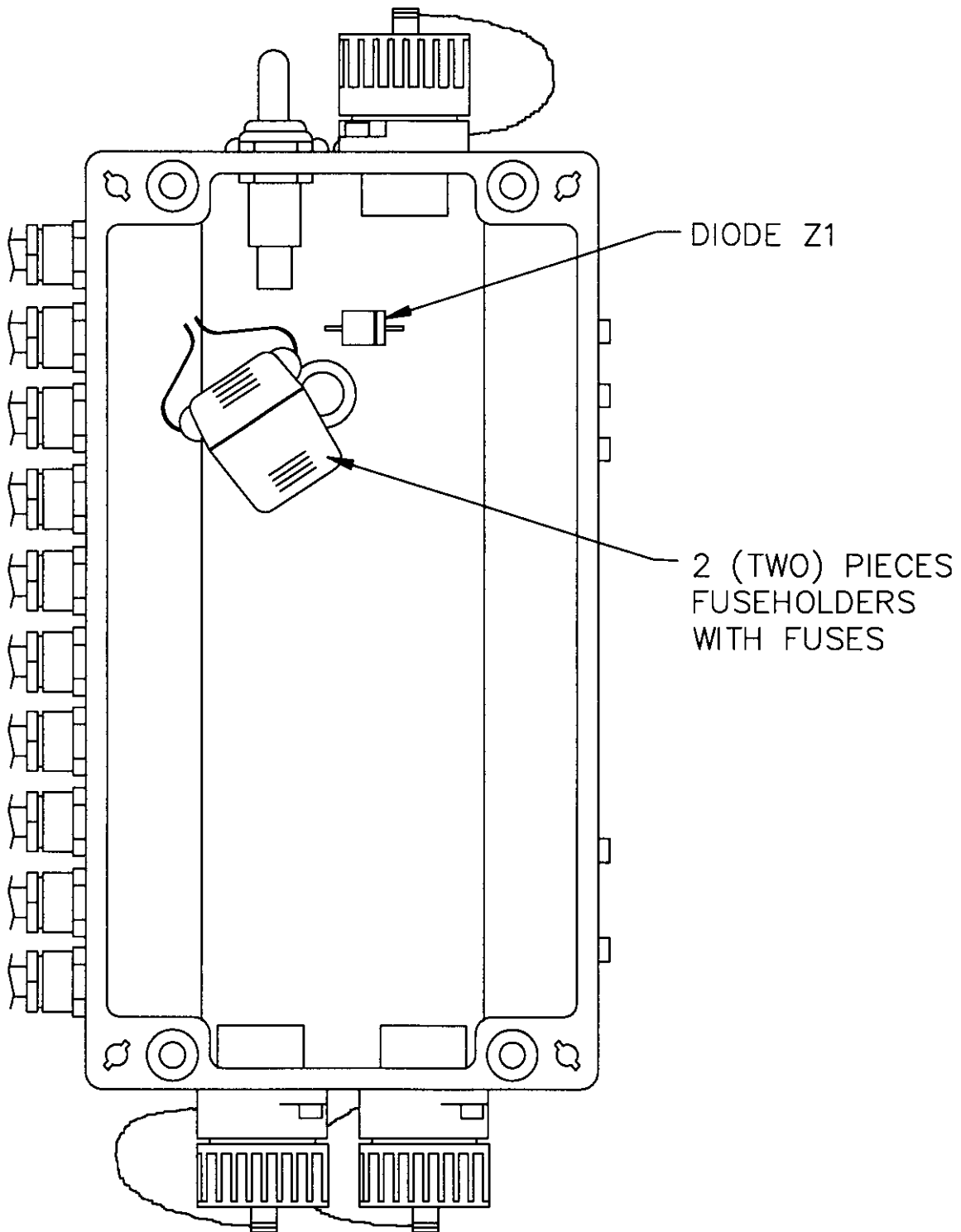

R93311E

- **Plus fuse: + 10 Amp. (Red) / (Standard car type fuse).**
- **Minus fuse: - 30 Amp. (Green) / (Standard car type fuse).**

1. WHOLE SYSTEM NON-FUNCTIONAL.

The **MANUAL / OFF / REMOTE** switch on the electronicbox can be used to select between manual operation and cable or radio control.

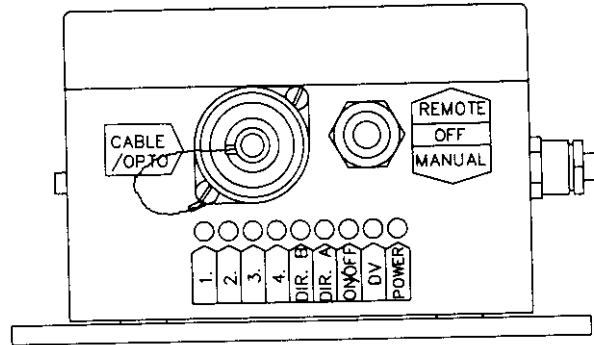

R93085

1.A. Electronicbox.

REMOTE position: No functions work and the electronicbox **POWER LED** not lit

MANUAL position: No functions work and the electronicbox **DV LED** not lit.

- 1.A1. Is the vehicle's ignition or power outlet switched on ?
- 1.A2. Is the crane emergency stop button pulled up ?
- 1.A3. Is switch **MANUAL / OFF / REMOTE** in the **OFF** position ?
- 1.A4. Check the power supply cables to the electronicbox, cable connections to the crane emergency stop switch and the two fuses in the electronicbox (See item 1.A5).
- 1.A5. The Electronicbox fuses are accessible after the lid has been removed and are standard car type.
PLUS fuse 10 Amp. (Red) , The fuse holder is marked: + 10 A.
MINUS fuse 30 Amp. (Green) , The fuse holder is marked: - 30 A.
(Blown fuses should not be replaced more than one (1) time without the short circuit having been located. If the MINUS-/GROUND fuse has blown make a careful check of the vehicle and electronicbox ground connections).
- 1.A6. Remove the connectors to the **ON/OFF** functions and radio receiver box.
- 1.A7. The electronicbox is probably faulty. Contact the service workshop, retailer or Scanreco, Sweden for recommended action.

1.B. Electronicbox.

MANUAL position: No functions work and the **DV LED** on the electronicbox is lit.
 (The crane cannot be manoeuvred manually).

- 1.B1. Check the electronicbox dump valve cable (**DV**) and valve contact.
 (Oxide, break or bad contact ?).
- 1.B2. Dump valve coil faulty.
- 1.B3. Dump valve hydraulic / mechanical function faulty.
- 1.B4. Fault in crane's hydraulics / mechanics.

1.C. Portable control unit and electronicbox.

Whole system non-functional, but:

Control unit red LED lit, electronicbox POWER LED lit and LED 4 blinking.

1.C1. During radio control: Test using cable control (control cable).

If it works with the cable, there is probably a fault in the radio transmitter, radio receiver box or in their connections. (Does the radio control unit match this electronicbox i.e. same ID code ?)

1.C3. During cable control (control cable):

Probably a fault in the control cable. Check the cable connections/contacts.

1.C4. Change and try a new control cable.

1.C5. Change and try a new control unit.

1.C6. Change and try a new electronicbox.

1.D. Portable control unit.

The red LED on the control unit does not light when the ON/SIGNAL/FREQ.-SHIFT switch is pressed.

(cable or radio control).

(The electronicbox switch *MANUAL / OFF / REMOTE* must be in *REMOTE* position, with *POWER LED* lit and *LED 4* blinking).

1.D1. Twist up the emergency stop switches on the portable control unit and on the crane.

1.D2. Radio control: Change the battery pack, check the condition of the batteries, check the battery charger, check the battery holder's terminals. Test with cable control.

Cable control: Check the cable control cable and its connection/contacts (breaks, intermittent contacts, shorts circuits).

1.D3. Unscrew the emergency switch panel and any extra switch panels.

1.D4. Check the connections to the battery, battery pack and control cable and all other connections to the control unit's electronics card. Check the emergency stop switch, emergency stop switch contact block. Check the ON/SIGNAL/FREQ.-SHIFT push button (Breaks ? Check continuity of the push button). Check the LED.

1.D5. Radio control: Remove the radio transmitter card (short circuits / high current consumption ?).

1.D6. Remove all manoeuvre levers (abnormally high current consumption ?).

1.D7. The control unit's electronics card is probably defective.

1.D8. Contact the service workshop, distributor or Scanreco, Sweden.

1.E. Portable control unit.

The control unit beeps and the red LED blinks when ON/SIGNAL/FREQ.-SHIFT pressed.

(cable or radio control).

*(Electronicbox switch **MANUAL / OFF / REMOTE** must be in **REMOTE** position, the **POWER LED** must be lit and **LED 4** must blink).*

For safety reasons all manoeuvre levers must be in the zero / neutral position in order for a start to be made. If any manoeuvre lever is not in the zero / neutral position during start-up, the control unit will beep and blink the same number of times as the number of the non-zeroed manoeuvre lever in order to indicate which manoeuvre lever is activated or in error. The control unit can be used, but the faulty lever will be locked and disconnected. (For example five (5) beeps and blinks which indicates that the 5th lever from the LEFT is faulty or moved from zero).

1.E1. Change the manoeuvre lever which is indicated as faulty. Check that the manoeuvre lever is connected to the electronic card in the control unit via the pin / socket strip.

Use care during the assembly.

If the fault is not fixed see item 1.E2.

1.E2. Change the electronic card in the control unit.

2. SOME PROPORTIONAL MOVEMENTS MISSING.

The whole system works, but a particular proportional movement is missing.

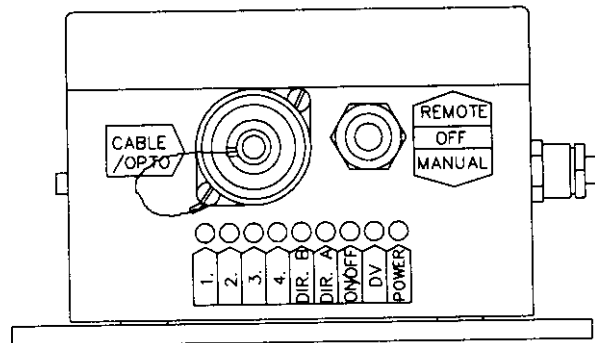

R93085

LED indication:

DIR. A: Manoeuvre lever in A-direction activated and moved. The intensity of the LED will increase with increased lever displacement. The LED is commoned and summed, i.e. only one manoeuvre lever at a time can be manoeuvred in A-direction for a check to be made.

DIR. B: Manoeuvre lever in B-direction activated and moved. The intensity of the LED will increase with increased lever displacement. The LED is commoned and summed, i.e. only one manoeuvre lever at a time can be manoeuvred in B-direction for a check to be made.

2A. DIR. A / DIR. B LEDs not lit, during manoeuvre of a certain prop. function from the control unit.

- 2.A1.** Change the manoeuvre lever, i.e. change the "non working" manoeuvre lever to a working function. If the fault moves on the control unit the manoeuvre lever is faulty.
1. Change the manoeuvre lever.
 2. Change the electronic card in the control unit.
 3. Change the electronicbox.
- 2.A2.** The function can also be tested with the "TEST-MODE".

2.B. DIR. A or DIR. B LEDs lit during manoeuvring from control unit but: A particular valve movement does not function.

- 2.B1.** Check the cable and valve contact between the electronicbox and the electro-hydraulic slide control.
- 2.B2.** Change the faulty valve contact on the electro-hydraulic slide control to a working function. If the function now works, then the fault was in the previous electro-hydraulic slide control
- Change the electro-hydraulic slide control/valve section.
- 2.B3.** Change the electronicbox.

2.C When manoeuvring is started with the "faulty" manoeuvre lever, movement stops.

2.C1. A short circuit, overload or other fault exists between the electronicbox valve cable and valve contact or in the electro-hydraulic slide control.

2.C1. Change the faulty valve contact on the electro-hydraulic slide control to a working function.

If the manoeuvre lever now works there is a short circuit or other fault in the electro-hydraulic slide control.

Change the electro-hydraulic slide control.

If it still doesn't work - see item 2.C2.

2.C2. Check the cable and valve contacts between the electronicbox and the slide control.
(Check the cable for damage, oxide etc.).

2.C3. Repair / fix / clean / grease any damage to the cable or valve contact.

2.C4. Change the electronicbox.

3. CERTAIN ON/OFF FUNCTIONS MISSING.

ON/OFF: ON/OFF function activated. The LED is commoned and summed, i.e. only one switch at a time can be activated from the control unit for the check to be made.

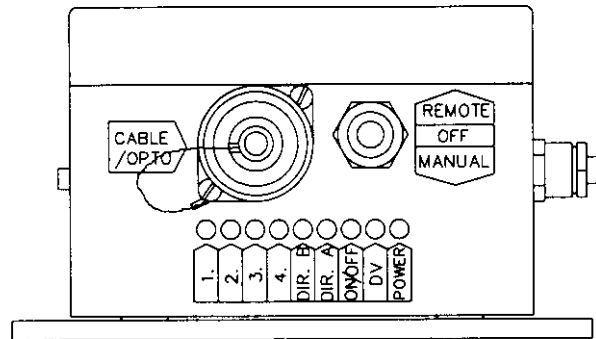

R93085

3. An ON/OFF LED does not light when a certain switch is activated on the portable control unit.

Test of the portable control unit:

3.A1. First check the control unit and its switches. The test is best made in the control unit's "TEST-MODE". (See section "TEST-MODE").

"TEST-MODE" selected: The control unit beeps when the "faulty" switch is activated, (i.e. switch and control unit OK) - go on to section 3.A2.

3.A2. "TEST-MODE" selected: The control unit does not beep when the "faulty" switch is activated.

Check the cable connections to the switch in the control unit.

Change the switch panel.

Change the electronic card in the control unit.

Test of electronicbox:

3.A3. Remove the ON/OFF cable (EX) connection from the electronics box. If the fault disappears see section 3.A4. If the fault remains there is a short circuit in the electronicbox ON/OFF contact or in its cable connections.

3.A4. Short circuit in the electronicbox ON/OFF cable (EX) or in its connections (Measure continuity).

Repair break, short circuit or change ON/OFF cable. (EX).

3.A5. ON/OFF function's current consumption exceeded (Max. 1.2 Amp. / function).

3.A6. Short circuit in the manoeuvred function (electro-magnet / coil / motor / relay etc.).

3.A7. Electronicbox drive stage faulty, change electronicbox.

3.B ON/OFF LED lights during activation, but function on crane not activated.

3.B1. Check the electronicbox ON/OFF cable (EX) and its connections (Measure continuity).

3.B2. Check the electronicbox ON/OFF contact (EX) and its connections in the box.

3.B3. Check the manoeuvred function's connections and its function.

PORTABLE CONTROL UNIT TEST-MODE .

Functional description.

To simplify service and faultfinding, the portable control unit can be put into internal **TEST-MODE**.

This means that the service man can easily control the control unit's switches and manoeuvre levers, without the need to open the control unit.

When each switch or manoeuvre lever is activated / manoeuvred the control unit gives a "beep - signal" to confirm that the function is working.

When "**TEST - MODE**" is selected no transfer of proportional, ON/OFF, or dump valve functions is made to the electronic box.

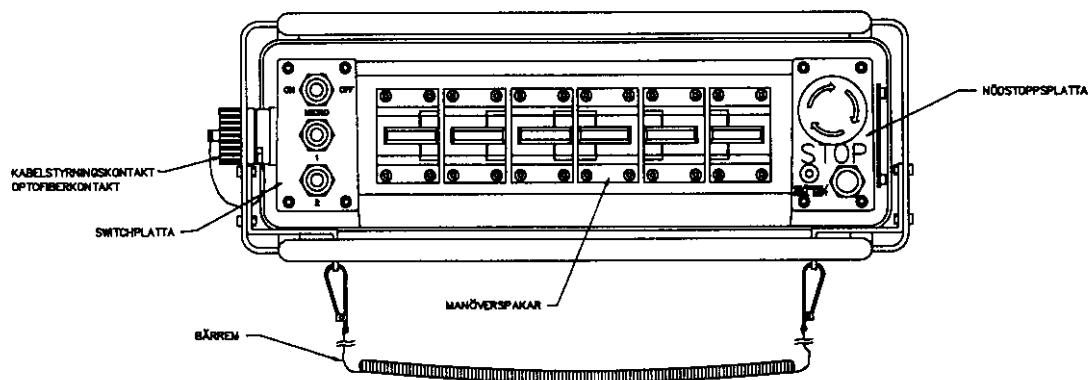

Do as follows :

1. Press emergency stop on the control unit.
2. Twist up the emergency stop on the control unit and press ON / SIGNAL / FREQ.-SHIFT.
3. Then press ON / SIGNAL / FREQ.-SHIFT ten (10) times in quick succession.
(This can be done either by cable or radio control).
4. The control unit's red LED should blink quickly.
(If the LED is lit continuously, restart from item 1).
5. The control unit **TEST-MODE** is now selected - see item 6.
6. Each time a switch is activated / manoeuvred the control unit should beep.
(If a particular switch does not beep, there must be a fault in the switch or in the control unit's electronic card).
7. Each time a manoeuvre lever is activated / manoeuvred a beep signal should be heard from the control unit which increases in "sound intensity" with lever displacement. The control unit beeps with a continuous tone when the manoeuvre lever is manoeuvred to maximum. This gives a confirmation that the control unit's levers have been manoeuvred fully / max.
(If a certain manoeuvre lever does not beep there is a fault in the manoeuvre lever, pin / socket contact or in the control unit's electronic card).
8. When testing of the control unit is completed, press down the emergency stop on the control unit. The control unit will now function normally.

RC 400 which only works with cable, not with radio.

A. Changing radio transmitter or radio receiver box.

Test first by changing the radio receiver box (i.e. the unit located on the crane).

1. Changing the radio receiver box.

Do not unscrew the entire radio receiver box, but do as follows :

- A. Unscrew and remove contact : "RADIO" from the electronicbox.
- B. Test by connecting the contact to the "new" radio receiver box.
- C. Test run the system with radio control.
- D. If it still does not work, see item 2.
- E. Screw back the contact from the "old" radio receiver box.
- F. The radio receiver box works but the radio transmitter is probably defective, see item 2 !

Note. If the GREEN LED does not light on both radio receiver boxes, there is probably a fault in the electronicbox radio contact or inside the electronicbox. Contact Scanreco, Sweden in this case.

2. Changing the radio transmitter (i.e. inside the portable control unit).

- A. Unscrew the 2 (two) screws on each short side on the under-side, i.e. a total of 4 (four) screws.
Pull the over and under sections carefully apart.
- B. Unscrew the radio transmitter (total of 4 screws) and replace it with an exchange unit.
To avoid intermittent contact/functional disturbances from the radio transmitter, the mounting screws for the "new" radio transmitter must be well tightened !!
- C. Replace the upper and lower halves, replace the screws and then test run.

If the radio units still does not work contact Scanreco AB, Sweden.

Repair of control cable.

General :

The control unit is connected to the electronic box via a thin and flexible 3-core cable. The cable has circular type connection contacts (Amphenol / Hirschmann) at each end.

Final control : Ohm measure the cable's contacts for check of continuity.

(*Rec. area : min. 0.5 mm²*).

Connections in the contact :

- 1 = Supply
- 2 = Data
- ⊥ = Ground/Minus

- 3 = *Not connected.*

Connecting :

K1 : K2 :

Ground ↔ Ground

1 ↔ 1

2 ↔ 2

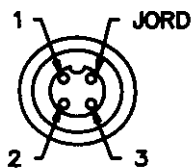

054

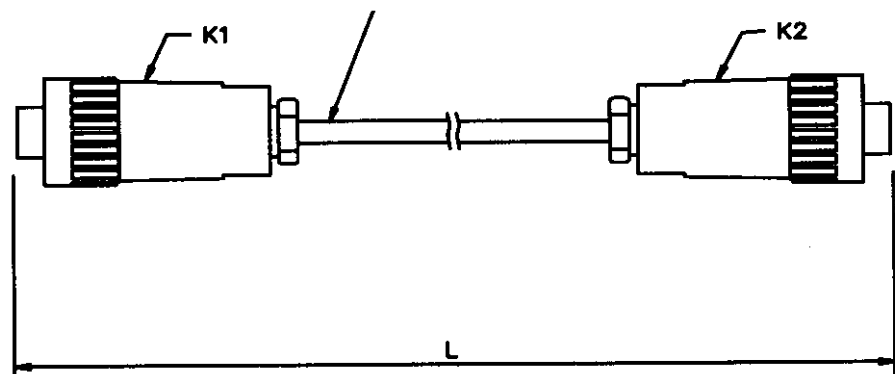

Programming of radio identity codes.

Do as follows :

1. Remove the battery pack from the control unit. Test run the system with cable control.
2. Leave the cable control connected between the control unit and the electronicbox.
3. Press the emergency stop on the control unit and then on the crane.

The red LED on the control unit must be off, and all LEDs on the electronicbox must also be off !!

4. Twist up the emergency stop on the crane and then on the control unit.
5. Press the ON/SIGNAL/FREQ.-SHIFT button (the red LED will light) and hold it down for at least 10 seconds. The control unit will beep in quick succession to confirm that programming is completed.
6. The programming is completed, remove the cable control, replace the battery pack and test run the crane with radio control.
7. If this procedure does not work, repeat the programming (see items 2-6). If it still does not work, contact Scanreco AB, Sweden.

Information.

During cable control, all control units can be used to the crane in question, i.e. during cable control the radio transmitter and radio receiver box and the identity code is disconnected automatically.

The battery is charged automatically during cable control.

6. SPARE PARTS.

RC 400 - SPARE PARTS AND SPARE PARTS LIST

Introduction.

The RC 400 remote control system is constructed using a number of standardised basic components which enables a minimum of spare parts stocks. No adjustments are required after the changing of system parts. This means quick, simple and effective service.

The spare parts list is divided into 10 (ten) main groups. The order number, part description and required quantity must always be given when spare parts are ordered. When ordering spare parts for a specific type of remote control please state the system model/type number and serial number (TYPE___ , Ser.No.____).

(Model labels are to be found on the control unit, electronicbox and radio receiver box).

Contents:

- **Portable Control unit (for cable or radio control).**
- **Control cable (electrical 3-core).**
- **Control cable (opto fibre cable).**
- **Crane emergencystop box.**
- **Electronicbox.**
- **Expansion cable (EX).**
- **Radio transmitter.**
- **Radio receiver box.**
- **Battery charger.**
- **Battery pack.**
- **Accessories / Options.**

8. PROGRAMMING PARAMETERS AND SETTINGS.

General description.

The Scanreco RC 400 offers considerable possibilities for system constructors of hydraulically driven mobile cranes and machines. The program in the control system is very comprehensive, flexible and has many adaptation possibilities for specific applications. The control system offers simple programming of a number of functions which can easily be turned on or off or altered during operation.

To obtain the best manoeuvre characteristics in the simplest way, all programming / calibration of manoeuvre characteristics is made during operation (so called on-line). All programming / calibration is made from the portable control unit. Programming is simple and does not require tools / instruments or any special knowledge.

(Programming can of course be also made from a PC / terminal).

The control system is furnished with and prepared for 2-way (duplex) communications and for signal handling of functions such as ramp, parallel, lock, "dead-man's", hold, double and overload / lift reduction etc.

THE SYSTEM HAS 4 LEVELS OF AUTHORISATION:

- Authorisation level 1. (Installer).
 - Authorisation level 2. (Well trained installer, well trained service personnel).
 - Authorisation level 3. (Well trained crane and valve manufacturer, well trained system constructor).
 - Authorisation level 4. (Scanreco AB, Sweden).
-
- **Authorisation level 1: (Installer).**
 - **1.A To change the direction of the crane.**
If the crane moves in the opposite direction to that which is desired.
 - **Authorisation level 2: (Well trained installer, well trained service personnel).**
 - **2.A Individual changes to the manoeuvre valve start speed for A or B ports.**
If the manoeuvre valve's starting value "dead-band" is to be increased or decreased for A or B port.
 - **2.B Individual speed reduction for A or B ports.**
Individual maximum manoeuvre speed reduction for a particular critical function (e.g. swing function). Fully variable speed reduction can be made for manoeuvre valves on the A or B ports. This enables the crane driver to pre-set the maximum oil flow for each individual function (A or B port) as required.
 - **2.C Individual changes to micro - speed control for A or B ports.**
Due to non-symmetry in certain valves hydraulic system or in the crane / machine the micro speed can be less well defined. If this is the case the micro-speed final speed can be changed and adjusted (i.e. for max. lever position) for A or B port for all movements.
Note.: After the completed adjustment of the micro-speed :
The remaining micro-speed's "reduction steps" will be proportional to the setting.

- 2.D Individual delayed start and stop movements (ramp functions acceleration and retardation).

Ramp functions give soft start and stop movements which protects the crane / machine against overloading during careless manoeuvring.

Start delay, i.e. this is the time required for the manoeuvre valve slide to reach its final position from the time the manoeuvre lever has left its neutral position. The time can be set individually to between 0 and 5 seconds for A and B ports. (See tables below !)

Stop delay, i.e. this is the time required for the manoeuvre valve slide to come to its neutral position after the manoeuvre lever has been placed in the neutral position. The time can be set individually to between 0 and 5 seconds for A and B ports. (See tables below !)

• **Authorisation level 3.**

(Only a few of the functions are described here) :

• **Individually programmable manoeuvre curves.**

The basic characteristics of the manoeuvre curves can be varied extensively. The manoeuvre curve in relation to the manoeuvre lever can be linear, linear with different curve slopes or with a break point in the manoeuvre curve. The appearance and characteristic of the manoeuvre curve can be individually installed for each valve section (A or B port) for example for a particular critical function.

• **Programming for the 7th and 8th valve movements or for serial tandem operation.**

• **Double function** (different control characteristics depending upon speed, ramps etc.).

• **Hold function:** (i.e. "lock" a function at a particular speed, after which the speed will be kept constant without the lever needing to be held).

• **Dead-man's function** (can be designed to cater for different safety requirements).

• **Individual or common reduction functions.** A reduction or stop can be ordered by external input signals in critical situations if the crane / machine becomes overloaded or / and overturns. External input signals can also cause reduction of speed of all functions to be made in the case of insufficient pump capacity. With external input signals, when the crane driver is working from a sky lift, an automatic reduction/decrease of speed can be made.

With external input signals the control system can always drive the support legs down but upwards only if the pressure in cylinder is so low that the vehicle is standing firmly. etc.

• **Automatic dumping:** (an optional time can be set for automatic dumping/unloading, which means unnecessary heat generation is avoided and a further increase in safety).

E.t.c.

The Installer/system designer is responsible for seeing that the RC 400 is used correctly for all applications and is responsible for any re-programming of the system functions and the characteristics changes caused by this.

*See section 2.D. Ramp times for various classes are given in the tables below (Classes 0 to 15) :
(Times can be set, as per the table, for delayed start and stop movements for A and B ports).*

Class	Ramp time (secs.)	Class	Ramp time (secs.)
0	0.0 sec.	8	1.0 sec.
1	0.1 sec.	9	1.2 sec.
2	0.2 sec.	10	1.5 sec.
3	0.3 sec.	11	1.7 sec.
4	0.4 sec.	12	2.0 sec.
5	0.5 sec.	13	2.5 sec.
6	0.6 sec.	14	3.5 sec.
7	0.8 sec.	15	5.0 sec.

Changing the direction of movement of the crane.

This describes how changes in direction of movement are made if the crane moves in the opposite direction to that desired.

Example:

After installation and test operation it is found that the 3rd and 5th lever movements operate in the opposite direction to that desired. See the example below for how to change the 3rd and 5th lever movements.

DO AS FOLLOWS!

1. Remove the battery pack. Connect the cable between the control unit and electronic box and test run the crane. Then press the emergency stop on the control unit and emergency stop on the crane.

2. Twist up the emergency stop on the control unit and on the crane.

3. Press the control unit's ON/SIGNAL/FREQ.-SHIFT button.
(The red LED should light continuously).

4. Produce impulses in very quick succession with spring return switch MICRO to RIGHT in the *OFF direction* until the control unit gives a long beep signal. Wait approx. 12 seconds until the next long beep signal then continue with item 5.

Note 1. The red LED will be extinguished each time the control unit gives a beep signal.

Note 2. If you do not receive the first long beep signal, start again from item 1 and execute items 3. and 4. quicker. Items 3. and 4. must be executed within max. 5 seconds.

5. Now press ON/SIGNAL/FREQ.-SHIFT once.

(The control unit's built-in beeper will give a short beep once every 5 seconds to confirm that the items above have been done correctly. If any other beep signals are heard you must restart from item 1 again).

Now you can easily change direction, see item 6.

6. Now you can operate the crane. Move the 3rd control lever (which is operating in the opposite direction to that desired) and give switch MICRO an impulse to the LEFT *in the ON direction*.

The crane will now change direction and continue with the same selected speed, in the opposite direction. Do the same with the 5th manoeuvre lever.

Move the 5th manoeuvre lever (which is operating in the opposite direction to that which is desired) and give toggle switch MICRO an impulse to the LEFT *in the ON direction*.

The crane will now immediately change direction and continue with the same selected speed in the opposite direction. *(If a direction change has been made earlier for a particular lever, do the same as above but give toggle switch MICRO an impulse to the RIGHT, in the OFF direction).*

Operate and check that all crane directions go in the desired direction.

7. Press the emergency stop on the CONTROL UNIT.

Programming is now completed and the crane is operating in the directions YOU decided in item 6.

(For radio operation, remove the cable control and test run the crane).

If you are not satisfied with any direction/directions, repeat these. See item 1.