

The VIP 5100 series lock is a microprocessor controlled, electromechanical locking system. It is an open architecture product designed to interface with 3rd party panels encompassing all the features of the lock, reader, door status* and egress (rex/request to exit) indication in one fire-rated piece of hardware. The 5100 employs a heavy-duty mechanical design tested and complying with ANSI/BHMA grade 1 standards for performance and reliability. It is powered by 12 or 24 volts DC with only four wires required - two for power and two for communications. The lock communicates with a PIB (panel interface board) which communicates with the panel as if it were separate components of an access control system.

Operationally, the outside lever is normally locked and the inside lever always retracts the bolt to allow egress. Electronic access control is achieved by entering an "Access Credential" (magnetic stripe card or Prox fob or card). The panel controls the lock through the PIB.

*Cylindrical model requires separate door status switch (included) to be installed in the door and frame and connected to the VIP lock.

Please refer to all instruction manuals involved in the installation before you begin.

Functions:

VIP 5196-FSA: Cylindrical, Fail Safe (unlocked)

VIP 5196-FSE: Cylindrical, Fail Secure (locked)

Models:

MG: Magnetic stripe card reader

PX: HID Prox card reader

Standard Monitoring Switches:

DSM: Provides door status via data link to panel interface

KSM: Provides mechanical key use events via data link to panel interface

REX: Provides indication of inside lever use for request to exit input via data link to panel interface

Options:

T3: Track 3 card reader (data must be ABA track 2 format) - MG only

EXT: exterior use option - MG only (PX model has this standard)

KD: Keyed Different, includes Schlage Everest cylinder

KA: Keyed Alike, includes Schlage Everest cylinder

LC: Less Cylinder

SLB: 2-3/4" backset, 1/2" latch bolt

OLB: 2-3/8" backset, 1/2" latch bolt

ELB: 2-3/4" backset, 3/4" latch bolt

BEFORE YOU BEGIN:

Standard units are shipped from the factory to fit 1-3/4" doors. Verify the door thickness. If the door is not 1-3/4" thick, verify that the door thickness option was ordered or consult factory.

PRE-INSTALLATION CHECK:

AN OPEN ARCHITECTURE SYSTEM REQUIRES AT LEAST THREE COMPONENTS - A PANEL INTERFACE BOARD (PIB), AN ACCESS CONTROL PANEL (BY OTHERS) TO WHICH THE PIB IS CONNECTED AND THE VIP LOCK. SEE DOCUMENTATION FOR THE ACCESS CONTROL PANEL/SOFTWARE THIS LOCK WILL BE USED WITH FOR ANY PRE-INSTALLATION TESTING REQUIREMENTS AND REMEDIES. REFER TO THE WIRING INFORMATION INCLUDED WITH THE PIB FOR MORE INFORMATION.

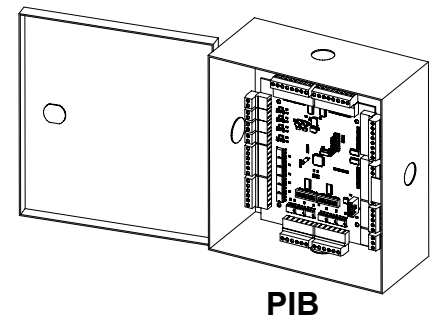
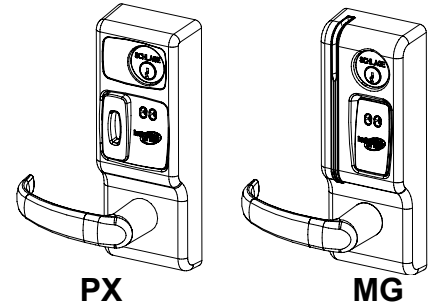

Door Thickness Kits:

Available in 1/8" increments from 1-3/8" to 2-1/2"

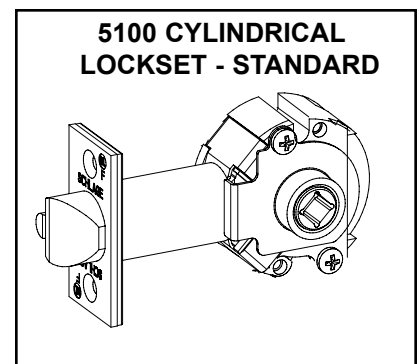

This device complies with part 15 of the FCC rules. Operation is subject to the following two conditions: (1) this device may not cause harmful interference, and (2) this device must accept any interference received, including any interference that may cause undesired operation. Changes or modifications not expressly approved by the party responsible for compliance could void the user's authority to operate the equipment.

WIRE RACEWAY REQUIRED:

It is best to have the wire race way prepared at the door and frame manufacturer. If this has not been done there are two suggested preparation methods for making wire paths for the FSE and FSA models in the field. Select method A or B; depending on the door and frame circumstances, one may be better than the other. *Consult door manufacturer with any questions regarding agency listings with respect to fire integrity.*

METHOD A:

1. Prep door and frame according to standard template.
2. Determine location of standard 1 inch wire harness through hole and mark centerline of hole on hinge side of door.
3. Using appropriate drilling jig and drill bits, drill 3/8" or 1/2" wire race from edge of hinge side into standard wire harness through hole.
4. Install electric hinge or door cord and run wires.

METHOD A:

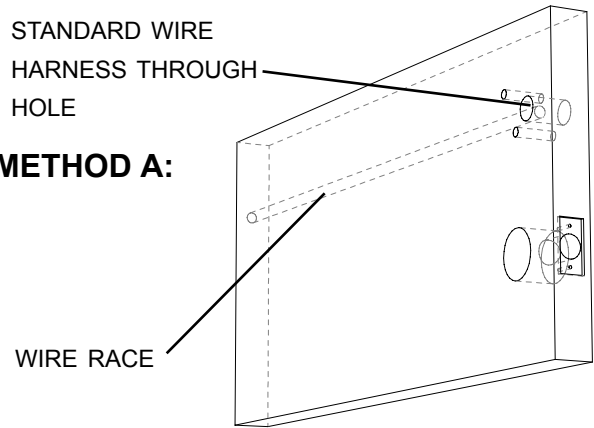

METHOD B:

1. Prep door and frame according to standard template.
2. Using a 1" drill bit, continue the 1" latch hole through retractor hole to a depth of 5". This will allow room for the wiring to pass around the retractor.
3. Using appropriate drilling jig and drill bits, drill 3/8" or 1/2" wire race from the latch hole through the door toward the hinge side. It is not necessary to continue drilling the hole through the hinge side.
4. Measure up 3 inches from the center of the 2 1/8" retractor hole and drill a 1 inch through hole on center as shown below.
5. Using a 3/8 inch drill bit, place the tip of the drill into the 1" wire hole drilled in step 3 and aim at the angles shown. Drill down and toward the hinge side to intersect the 1" latch hole (where it was continued in step 2).
4. Install electric hinge or door cord and run wires.

METHOD B:

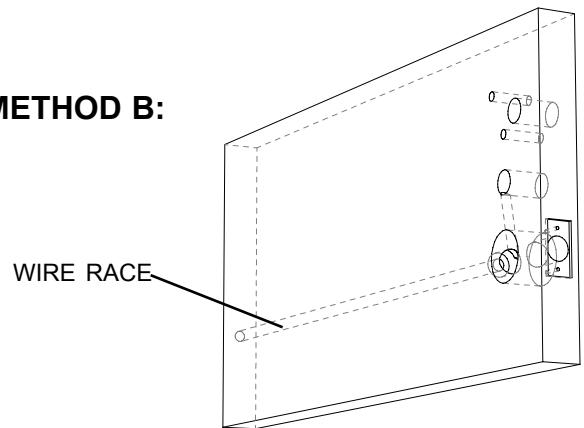

Note: this method offers the advantage of not having holes exiting the door edges. If a door cord is used the door cord wire hole can be cross drilled into the long wire race.

FSE & FSA HARD WIRED MODELS REQUIRE WIRING TO BE RUN TO THE LOCK PREP FROM THE HINGE SIDE. BELOW IS A SUGGESTED METHOD TO DO THIS. A DOOR CORD OR ELECTRIC HINGE OR POWER TRANSFER DEVICE IS USED TO ROUTE WIRING FROM FRAME TO DOOR. NOTE THAT WHEN USING AN ELECTRIC HINGE IT IS RECOMMENDED THAT THE POWER WIRES BE DOUBLED OR TRIPLED UP (ON BOTH THE POSITIVE AND GROUND LEGS) TO AVOID SIGNIFICANT VOLTAGE DROP THROUGH THE THIN WIRES IN THE HINGE.

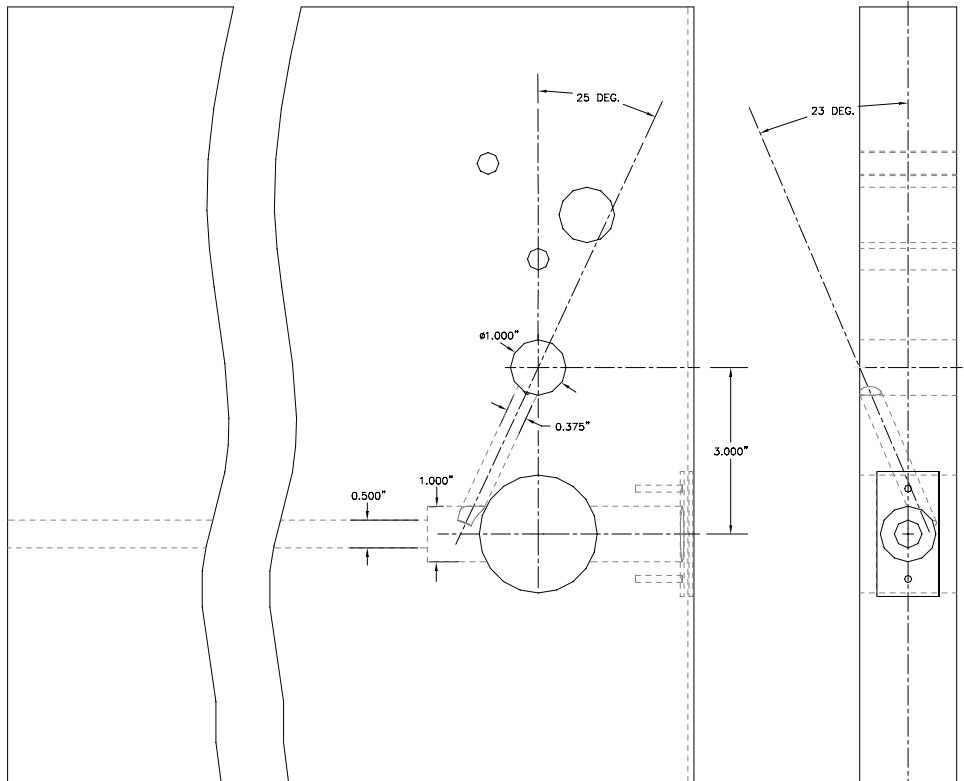

1. PREP DOOR AND FRAME:

- A. Determine door hand and correct backset.
- B. Mark the horizontal and vertical centerlines for the lockset, latch and strike.
- C. Place template on inside of door (opposite the side that the keypad/reader will be on). Line up the correct reference lines on the template with the edge of the door. The centerline on the door should line up with the vertical centerline of the template.
- D. Drill holes as described by template.

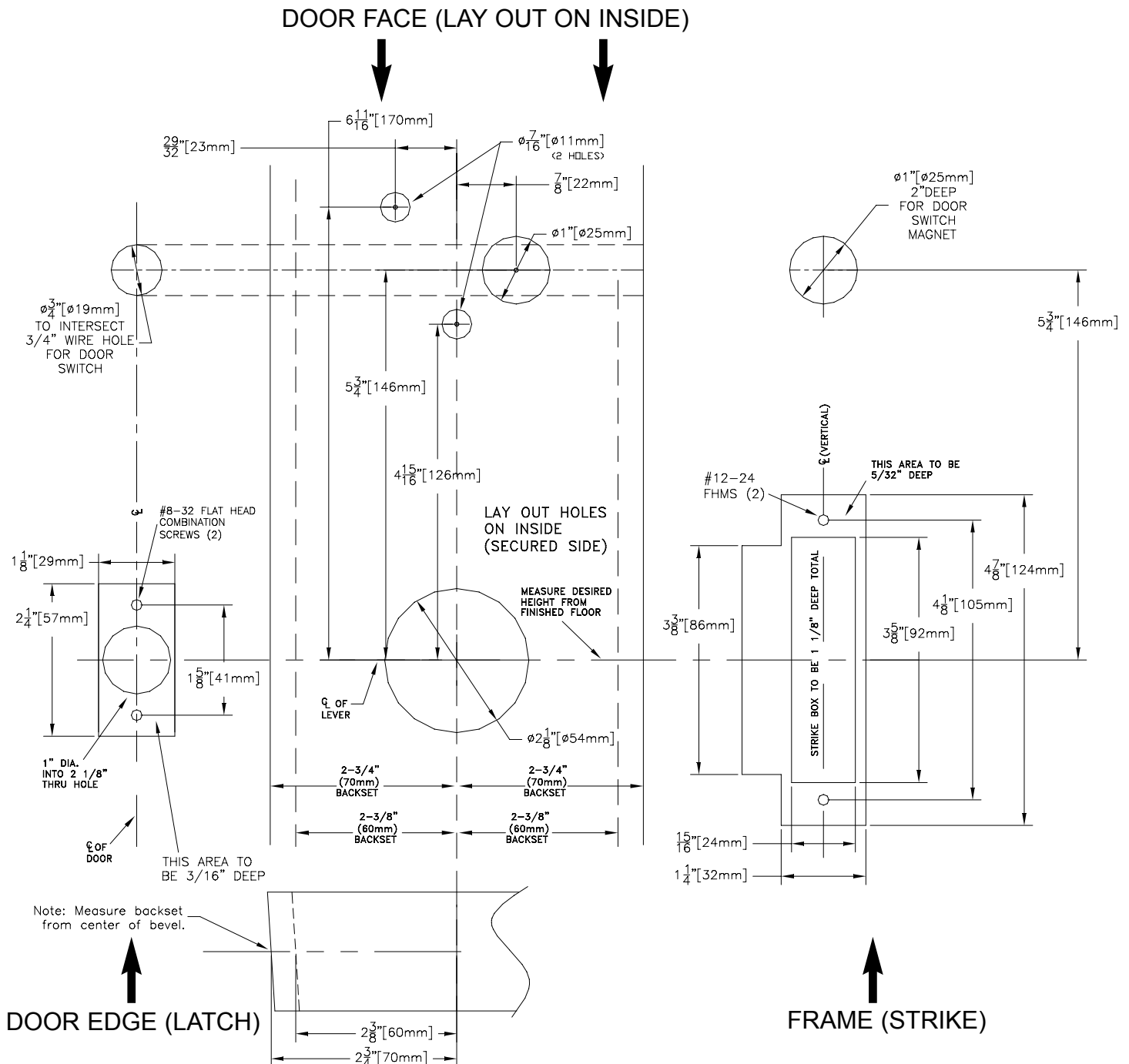

2. INSTALL CYLINDER (IF NOT ALREADY DONE), GASKET AND STANDOFFS:

- A. Install cam onto cylinder (if not already done.) Cam must be a straight 11/16" design. See below for recommended cams.
- B. Insert mortise cylinder into outside escutcheon from front (keypad/reader) side with keyway down.
- C. Slide lock washer onto cylinder (tab on top facing out, as shown below.)
- D. Using nut tool (provided) tighten nut onto cylinder.
- E. Line up nearest notch on nut with tab on lock washer and bend tab using nut tool so nut is secure.
- F. Install exterior gasket (if used).
- G. Install standoffs.

TEST KEY OPERATION NOW: Turning key clockwise until it stops (about 1/2 turn) should allow the lever to turn retractor.

RECOMMENDED CAMS:

SCHLAGE EVEREST: P/N B502-948

SCHLAGE CLASSIC: P/N B502-191

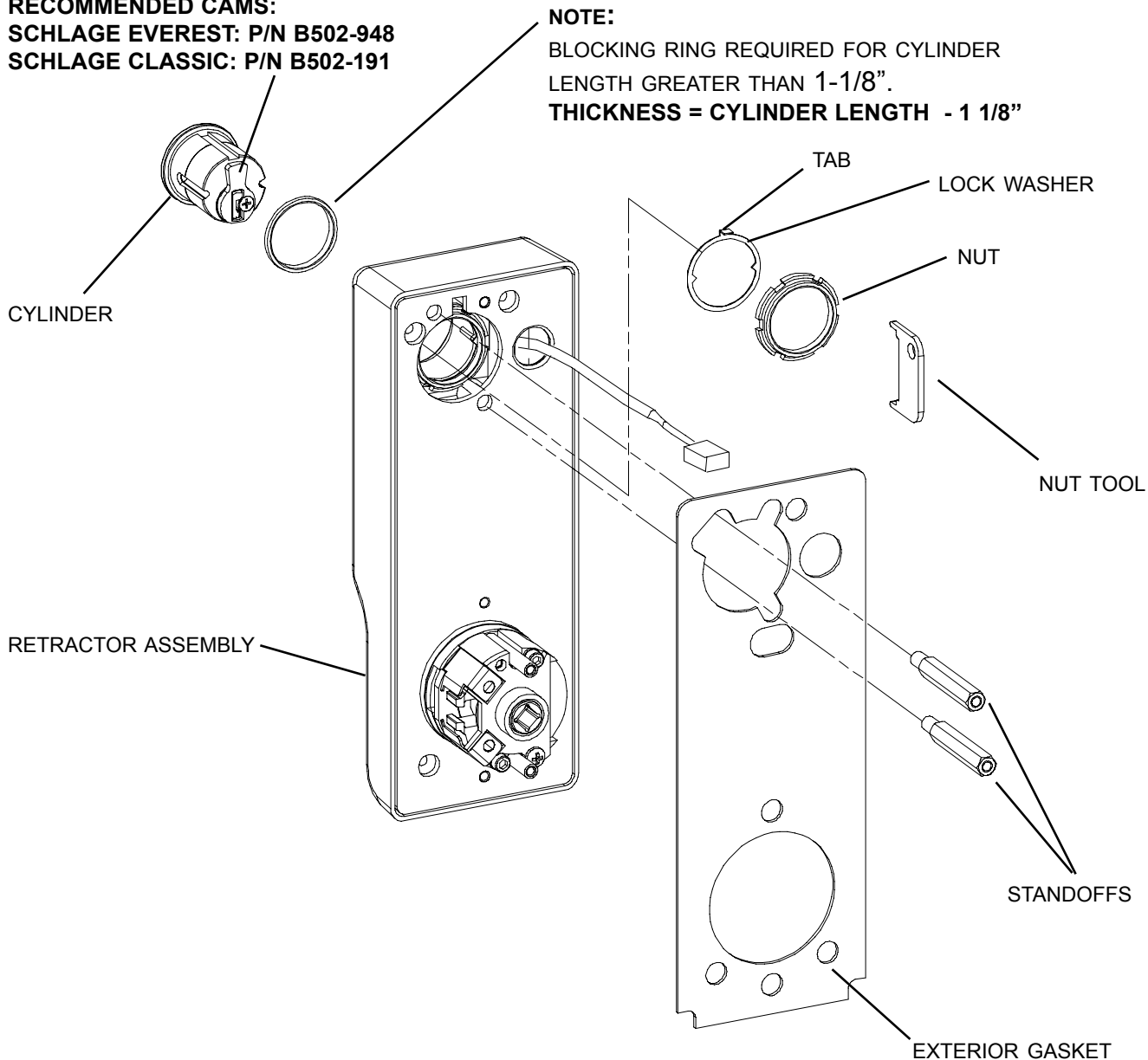

3. CHANGE HAND (IF NECESSARY):

NOTE: The locks are shipped handed as ordered from factory. follow the steps below to reverse the handing:

- A. Remove retractor by loosening two 9/64" socket cap screws which attach it to the outside escutcheon.
- B. Remove outside spindle.
- C. Loosen 5/32" socket cap screw which secures handle to escutcheon.
- D. Remove, rotate and re-install handle (NOTE: some handle designs have an adapter.)
- E. Re-install outside spindle, making sure that the round end faces the handle, and the spindle is positioned with its edges vertical and horizontal as shown in detail below. Note that the cam (inside the escutcheon assembly) must be positioned such that the dot on it faces the 6 O'Clock position (see detail below).
- F. Rotate retractor and re-install it.
- G. Change the hand of the handle on the inside escutcheon (not shown) the same way. Note that the inside escutcheon has no retractor.

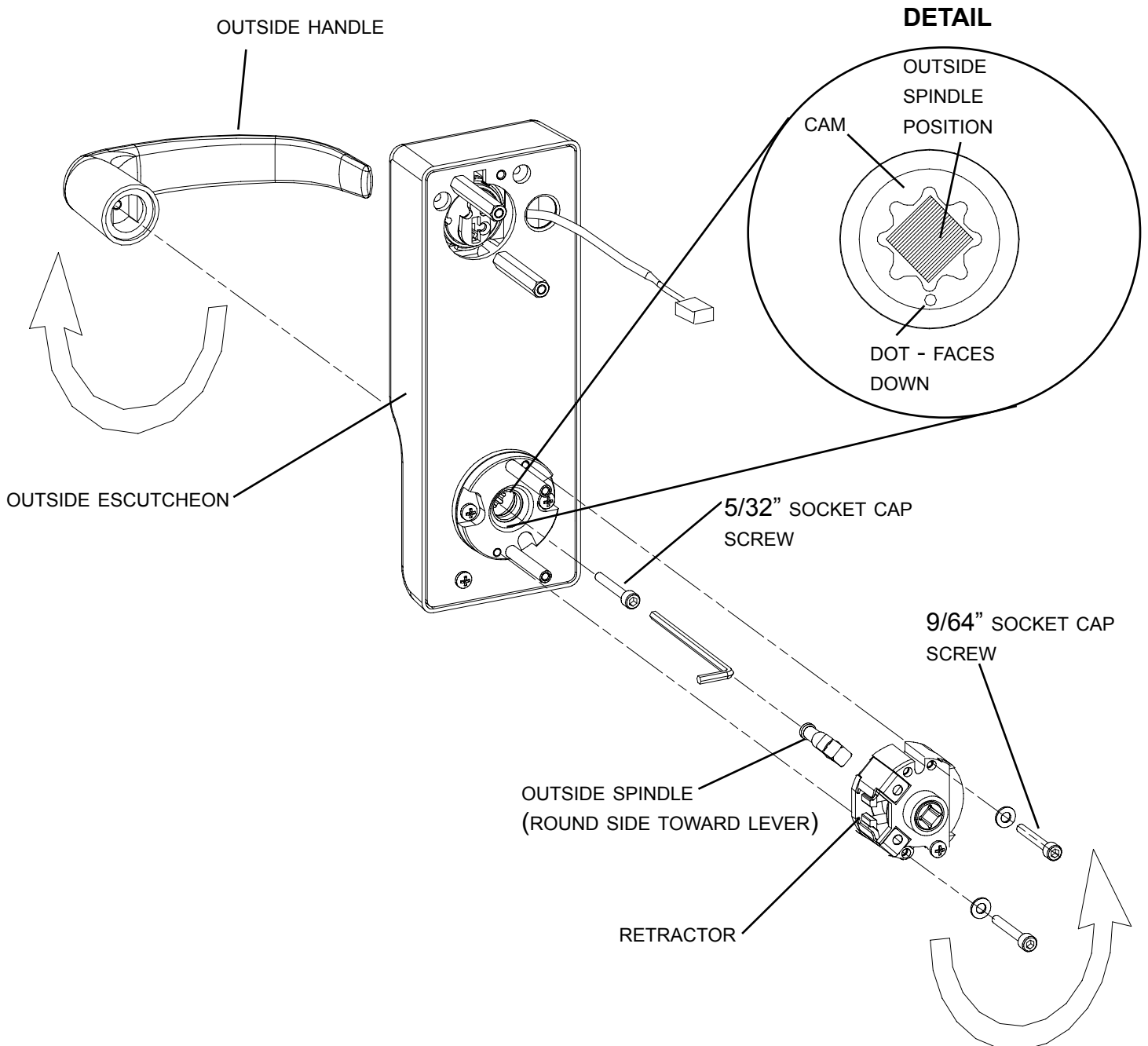

4. INSTALL STRIKE BOX, STRIKE AND DOOR SWITCH MAGNET:

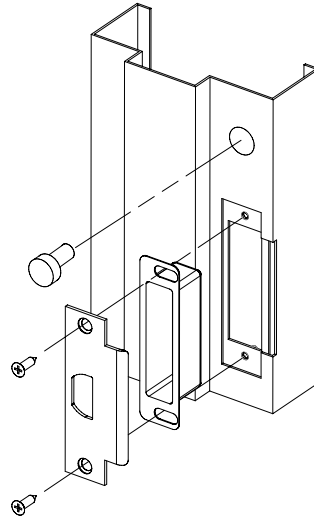

5. INSTALL LATCH AND DOOR STATUS SWITCH:

- A. Install latch into edge of door. Be sure to install it with the beveled edge facing door jamb.
- B. Install switch as shown, passing switch wires through to the inside of the door.

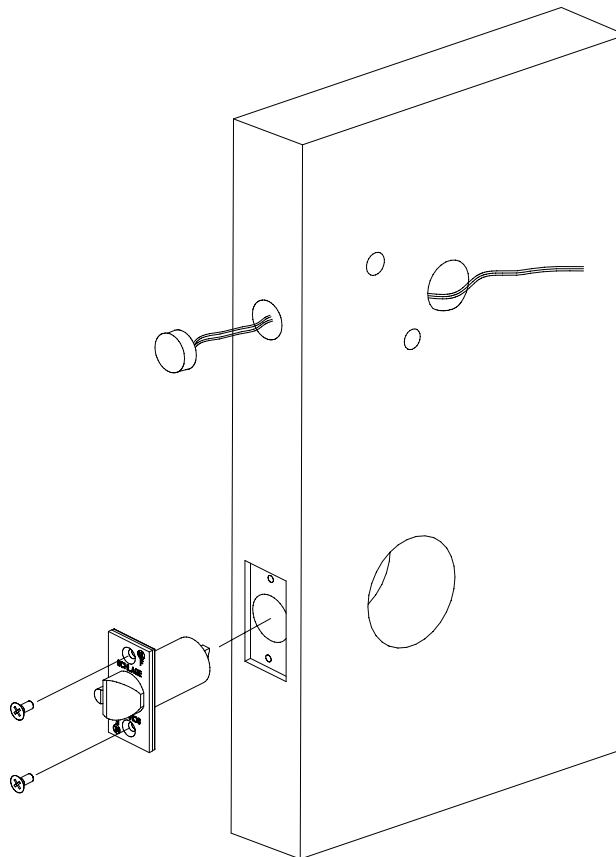

6. INSTALL OUTSIDE ESCUTCHEON ASSEMBLY:

- A. Remove latch guard from retractor.
- B. If the door is less than 1-3/4" thick, install spacer plate provided.
- C. Install outside escutcheon onto door (see detail for latch engagement). Pass wiring harness through wire hole.
- D. Re-install latch guard onto retractor.

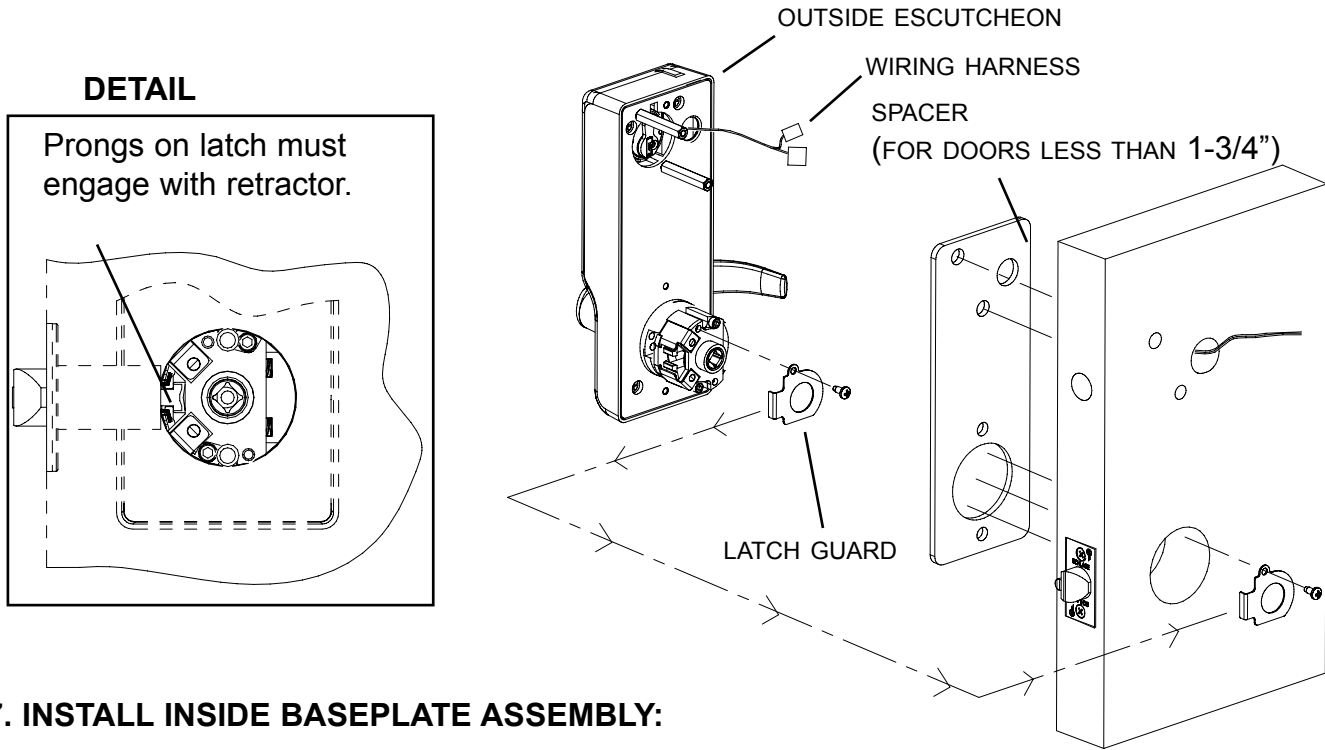

7. INSTALL INSIDE BASEPLATE ASSEMBLY:

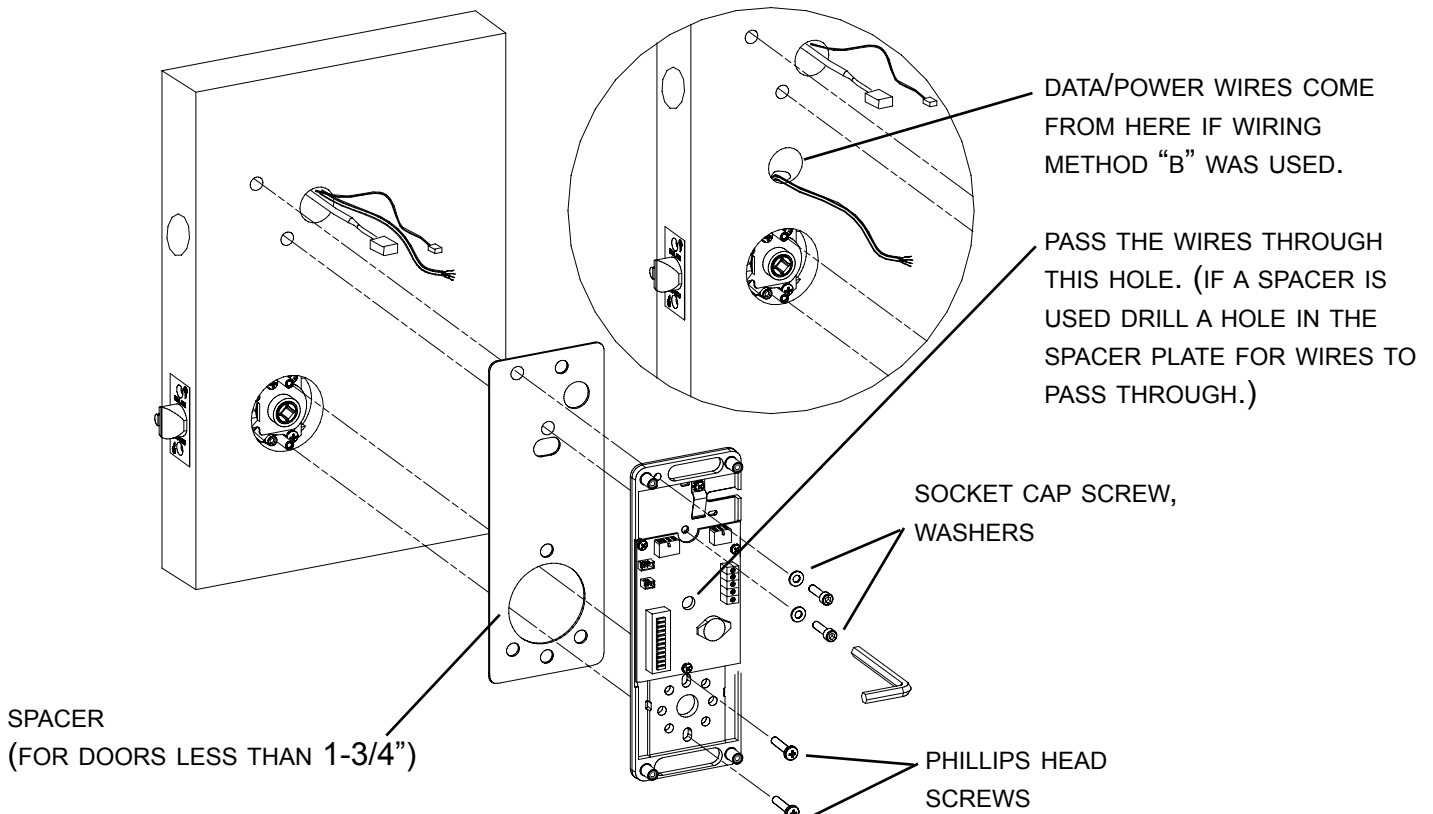

8. MAKE WIRING HARNESS CONNECTIONS :

- A. Plug MAIN WIRING HARNESS into PC board.
- B. Plug MAKE FIELD CONNECTIONS TO TERMINAL BLOCK.
- C. Plug in DOOR STATUS SWITCH as shown.
- D. Verify correct lock type setting (FSE/FSA) - see dip switch setting. Note: as ordered from the factory.
- E. If lock is the one farthest away from PIB set termination resistor to "on". All others should be in the "off/parked" position.
- F. Test operation of inside lever to make sure that latch retracts fully.

IMPORTANT! See PIB manual for additional connecting instructions.

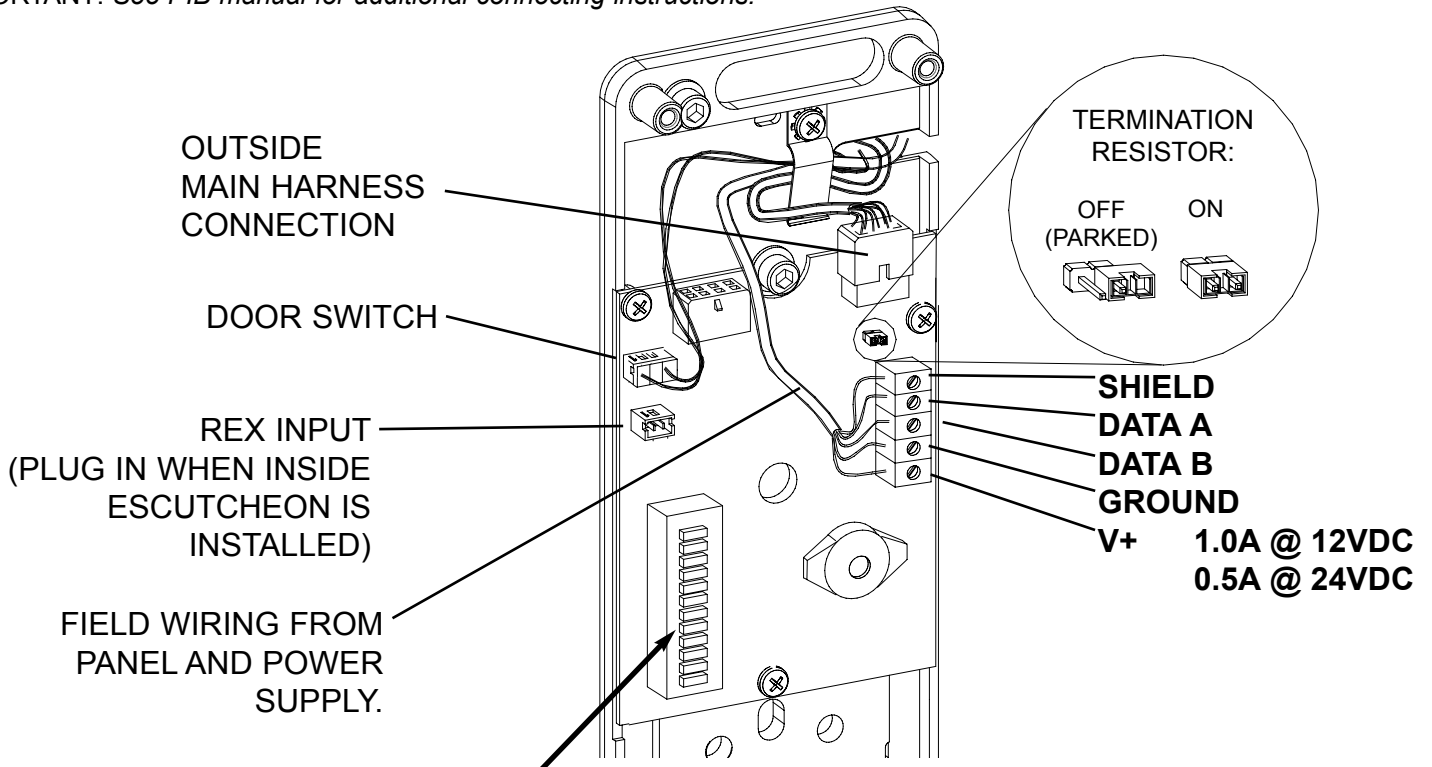

DIP SWITCH NUMBER:		LOCK ADDRESS 1	LOCK ADDRESS 2	LOCK ADDRESS 3	LOCK ADDRESS 4
1:	LOCK ADDRESS (SEE CHART)				
2:	LOCK ADDRESS (SEE CHART)				
3:	ALWAYS SET TO OFF				
4:	ALWAYS SET TO OFF				
5:	OFF = FAIL SECURE (FSE) ON = FAIL SAFE (FSA)	DIP SWITCH 1	OFF	ON	OFF
6:	OFF = ALL MG LOCKS ON = ALL PX LOCKS	DIP SWITCH 2	OFF	OFF	ON
7:	ALWAYS SET TO OFF				
8:	ALWAYS SET TO OFF				
9:	ALWAYS SET TO OFF				
10:	ALWAYS SET TO OFF				

Note:
Lock addresses must be used in sequence and cannot be the same for any two locks connected to a PIB. For example, if the system has three locks, use addresses 1, 2, and 3 (but not 4). Lock address will correspond to panel address on the PIB.

9. INSTALL INSIDE ESCUTCHEON:

Install inside escutcheon assembly onto inside baseplate using four screws.

IMPORTANT!

1. MAKE SURE THAT INSIDE SPINDLE IS INSTALLED.
2. PLUG REX SWITCH IN TO BOARD.
3. DO NOT PINCH WIRES BETWEEN PARTS.

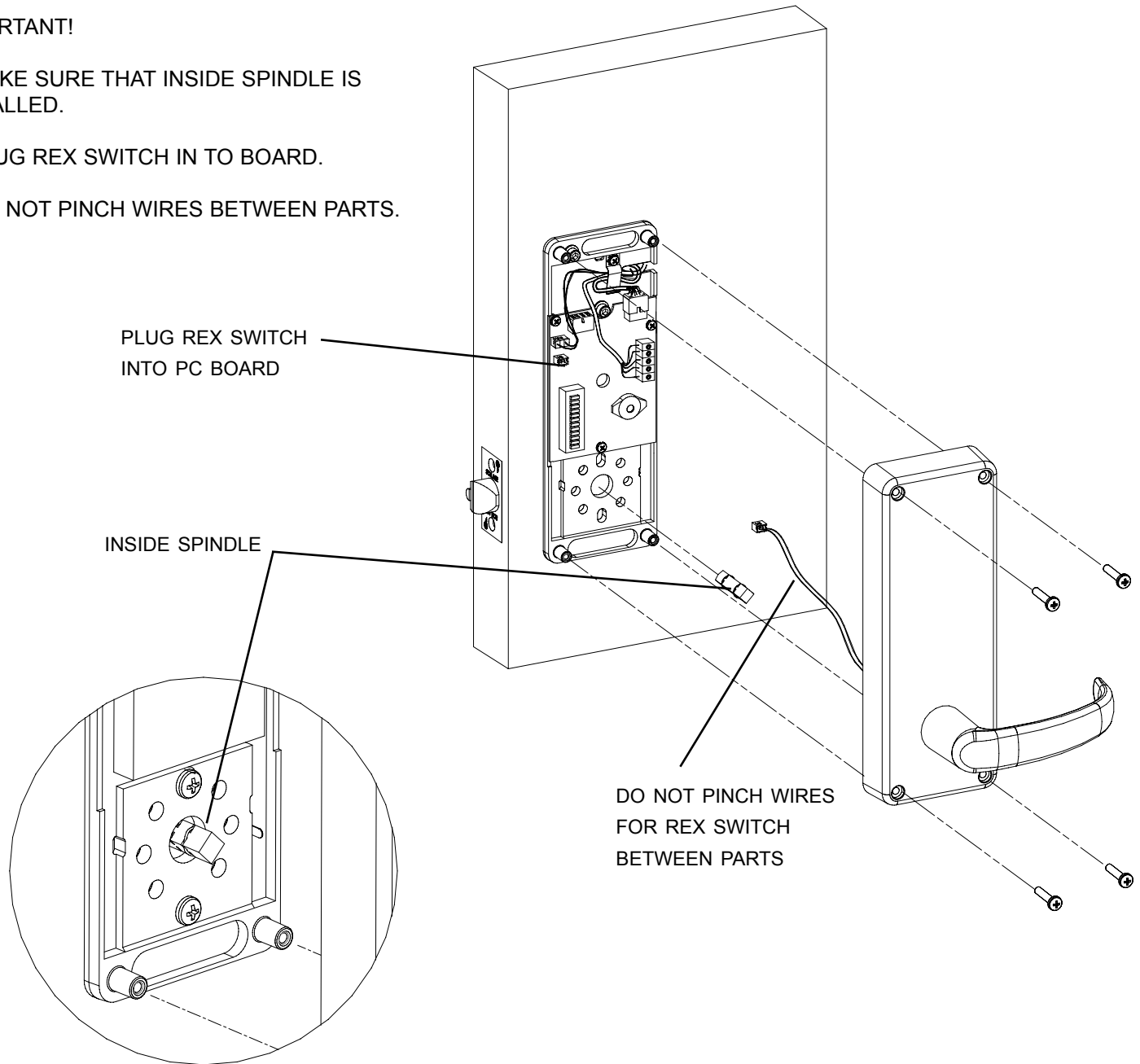

10. SEE PIB MANUAL AND SYSTEM/PANEL MANUAL FOR SET UP PROCEDURES.